



# VICTORIA GOVERNMENT GAZETTE

Published by Authority

No. 10]

WEDNESDAY, FEBRUARY 16

[1977

## PROCLAMATIONS

### ROADS PROCLAIMED.

#### PROCLAMATION

By His Excellency the Governor of the State of Victoria and its Dependencies in the Commonwealth of Australia, &c., &c., &c.

In pursuance of the provisions of section 25 (3) (c) of the Land Act 1958, I the Governor of the State of Victoria, by and with the advice of the Executive Council of the said State, do hereby proclaim as roads the under-mentioned lands:—

Township of Bright, Parish of Bright, County of Delatite, being the land indicated by hatching on plan hereunder.—(B.573<sup>(a)</sup>) (H.O.34825).

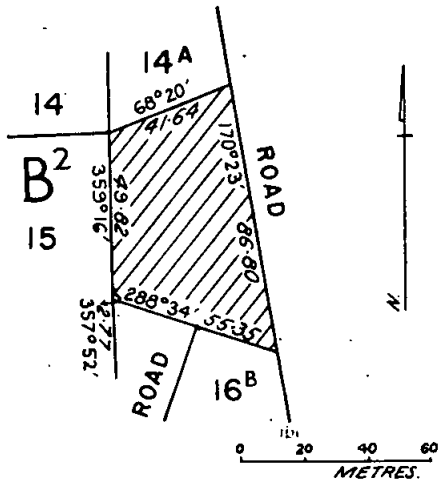

Township of Yackandandah, Parish of Yackandandah, County of Bogong, being the land indicated by hatching on plan hereunder.—(Y.45<sup>(17)</sup>) (H.O.35808).

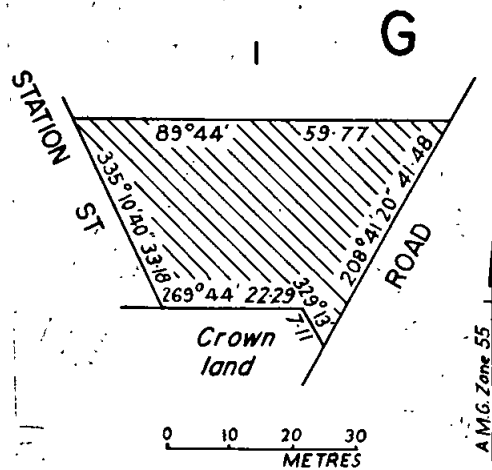

Given under my Hand and the Seal of the State of Victoria aforesaid, at Melbourne, this eighth day of February, in the year of our Lord One thousand nine hundred and seventy-seven, and twenty-sixth year of the reign of Her Majesty Queen Elizabeth II.

(L.S.) HENRY WINNEKE,

By His Excellency's Command,

W. BORTHWICK,  
Minister of Lands.

GOD SAVE THE QUEEN!

PUBLIC HIGHWAYS.—CITY OF CROYDON.

PROCLAMATION

By His Excellency the Governor of the State of Victoria and its Dependencies in the Commonwealth of Australia, &c., &c., &c.

Whereas by the *Local Government Act 1958*, section 519 it is amongst other things enacted that it shall be lawful for the Governor in Council at any time and from time to time upon the request of the Council of any municipality by notice in the *Government Gazette* to proclaim any land reserved used or by purchase or exchange acquired for a street, road, highway, thoroughfare, bridge, square, court, alley, or right-of-way or any street, road, lane, or passage made or laid out or proposed to be made or laid out, on any land of which a plan of subdivision delineating that street, road, lane or passage has been sealed with the seal of the municipality under subdivision (3) of Division 9 of Part XIX, or a corresponding previous enactment to be a public highway and that such land shall thereupon and thenceforth from that date of such proclamation become and be absolutely dedicated to the public as a public highway within the meaning of any law then or thereafter in force.

And whereas the Council of the City of Croydon has requested that the lands hereinafter mentioned, being roads laid out on land of which a plan of subdivision delineating the streets, roads, lanes or passages has been sealed with the seal of the municipality under subdivision (3) of Division 9 of Part XIX, of the *Local Government Act 1958*, or a corresponding previous enactment, be so declared to be public highways.

Now therefore, I, the Governor of the State of Victoria, in the Commonwealth of Australia, by and with the advice of the Executive Council of the said State, do by this Proclamation declare that Kerry and Bemboka Roads shown by brown colour on Plan of Subdivision No. 43609 and part of Merrill Crescent shown by hachure on the plan hereunder shall be a public highway within the meaning of the said Act.

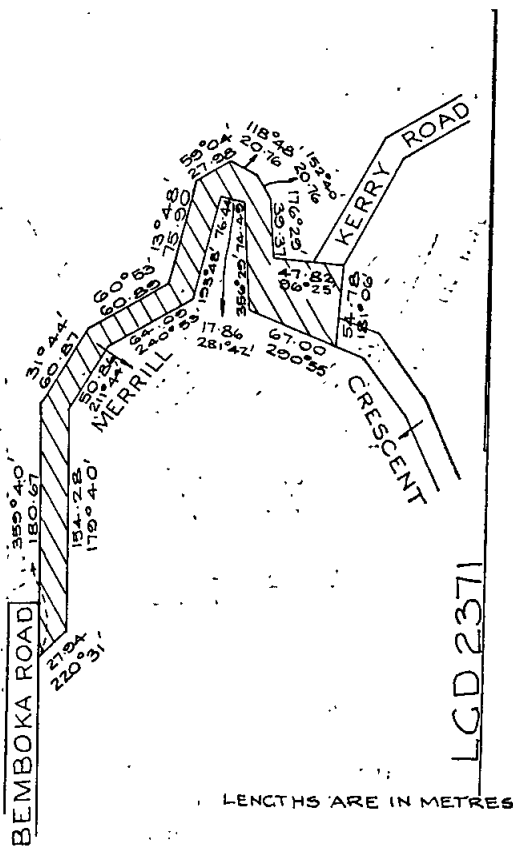

Given under my Hand and the Seal of the State of Victoria aforesaid, at Melbourne, this eighth day of February, in the year of our Lord One

thousand nine hundred and seventy-seven, and in the twenty-sixth year of the reign of Her Majesty Queen Elizabeth II.

(L.S.) HENRY WINNEKE.

By His Excellency's Command,

A. J. HUNT,  
Minister for Local Government.

GOD SAVE THE QUEEN!

MARKETING OF PRIMARY PRODUCTS (MARKETING BOARDS) ACT 1976.

DATE OF COMING INTO OPERATION.

PROCLAMATION

By His Excellency the Governor of the State of Victoria and its Dependencies in the Commonwealth of Australia, &c., &c., &c.

Whereas by an Act of Parliament of the State of Victoria passed in the twenty-fifth year of the reign of Her Majesty Elizabeth the Second, Queen of Australia, entitled the *Marketing of Primary Products (Marketing Boards) Act 1976*, it is amongst other things enacted that the several provisions of the said Act shall come into operation on a day or on the respective days to be fixed by proclamation or successive proclamations of the Governor in Council published in the *Government Gazette*:

Now therefore I, the Governor of the State of Victoria, in the Commonwealth of Australia, by and with the advice of the Executive Council of the said State, do by this Proclamation fix Friday, the first day of April, One thousand nine hundred and seventy-seven as the day on which the whole of the said *Marketing of Primary Products (Marketing Boards) Act 1976*, No. 8965, shall come into operation.

Given under my Hand and the Seal of the State of Victoria aforesaid, at Melbourne, this fifteenth day of February, in the year of Our Lord One thousand nine hundred and seventy-seven, and in the twenty-sixth year of the reign of Her Majesty Elizabeth the Second, Queen of Australia.

(L.S.) HENRY WINNEKE.

By His Excellency's Command,

IAN SMITH,  
Minister of Agriculture.

GOD SAVE THE QUEEN!

GOVERNMENT NOTICES

COUNTRY FIRE AUTHORITY.

PERMISSION TO HOLD FIRE BRIGADE DEMONSTRATIONS.

In pursuance of the provisions of section 103 of the *Country Fire Authority Act 1958*, the Country Fire Authority has granted permission for the holding of fire brigade demonstrations as under:—

RURAL FIRE BRIGADES.

- At Mandurang on Monday, 14th March, 1977.
  - At Ouyen on Friday, 18th March, 1977.
  - At Axe Creek on Saturday, 26th March, 1977.
  - At Rosedale on Sunday, 27th March, 1977.
- 11th February, 1977.

J. L. ALLEN,  
Secretary.

Motor Car Act 1958.

ADULT RACING HARNESS.

Notice is hereby given that the undermentioned adult racing harness manufactured to standard E35 of the Standards Association of Australia is approved by me for the purpose of Section 31A of the *Motor Car Act 1958*, No. 6325:—

Manufacturer	Abridged Description of Harness
Cooldrive Industries, King William Street, Vic. 3047.	Part No. RB 400 or BB 400—Adult Four (4) Point Racing Harness.
(Devices marketed under Repco and Bodigard brands).	(Suitable for front bucket seats only).

R. JACKSON,  
Chief Commissioner of Police.

Transport Regulation Act.  
TRANSPORT REGULATION BOARD.

## HEARING OF APPLICATIONS.

Notice is hereby given that the following applications will be considered by the Transport Regulation Board on 8th March, 1977.

ANDRIOPOULOS, J., Clifton Hill. Application to license one commercial passenger vehicle with seating capacity for eleven persons to operate for the carriage of Greek language students as follows: (i) Between the corner of Gilbert Road and Murray Road Reservoir and the Reservoir East Primary School in Boldrewood Parade. Passengers picked up in the Reservoir area east of High Street.

## TIME-TABLE.

Monday and Thursday between 3 p.m. and 8 p.m.  
(ii) Between the corner of Mahoneys Road and High Street Thomastown and the Thomastown East Primary School in Cedar Street. Passengers picked up in the Thomastown and Loral areas east of High Street.

## TIME-TABLE.

Wednesday between 3 p.m. and 8 p.m.  
Saturday between 9 a.m. and 7 p.m.  
(iii) Between the corner of St. Georges Road and Brunswick Street, Fitzroy North and the Clifton Hill Primary School in Spensley Street. Passengers picked up in the Fitzroy North, Fitzroy, Collingwood, Abbotsford and Clifton Hill areas.

## TIME-TABLE.

Tuesday and Friday between 3 p.m. and 8 p.m.

CLARK, G. W. & B. A., Cressy. Application for variation of conditions of licence T.S.1437 which authorizes the Berrybank-Cressy School service and licence T.S.1536 which authorizes the Shelford-West Ballarat School service to include the ability to undertake charter hirings statewide from within a 2-km pick-up radius of the Cressy Post Office.

FRASER, C. C., Echuca. Application to license one commercial passenger vehicle with seating capacity for 39 persons to operate between Roslynmead and Echuca for the carriage of school children only under contract to the Education Department.

HEAP, A. F. & G. B., Cohuna. Application to license one commercial passenger vehicle with seating capacity for 41 persons to: (a) Operate between Koondrook and Kerang for the carriage of school children under contract to the Education Department. (b) Undertake charter hirings from Kerang. (c) For the carriage of adult passengers at Railway fares by arrangement between the Education Department and the Victorian Railways Board.

HUMPHREY, E. J. & M. R., Nyah. Application to license one commercial passenger vehicle with seating capacity for eighteen persons to operate a stage service between Piangil and Swan Hill via Nyah, Nyah West and Pira for the carriage of passengers and parcels under contract to the Victorian Railways Board at V.R.B. fares and parcels rates.

## TIME-TABLE.

Depart Piangil 7.05 a.m.  
Arrive Swan Hill 8.00 a.m.  
Depart Swan Hill 5.45 p.m.  
Arrive Piangil 6.40 p.m.

HUMPHREY, E. J. & M. R., Nyah. Application to license one commercial passenger vehicle with seating capacity for 39 persons to operate between Woorineen South and Swan Hill for the carriage of school children under contract to the Education Department, and in addition, to carry adult passengers at railway fares by arrangement between Education Department and the Victorian Railways Board.

MERRETT, D. J., Kaniva. Application to license one commercial passenger vehicle with seating capacity for eighteen persons to operate: (a) A feeder service from the Yanipy Road area to meet the Lawloit bus at the corner of Webbs Road and the Western Highway, for the carriage of school children only, under contract to the Education Department. (b) Day and half day tours as presently authorized under licence T.O.10.

NOTE.—This application is subject to cancellation of licence T.O.10.

ROBERTS, A. G., PTY. LTD., Kyneton. Application for variation of conditions of licence C.O.691 which authorize the Lancefield-Clarkefield stage service to include the

ability to undertake charter hirings from within a 16-km radius of Kyneton to places within an 80-km radius of Kyneton.

THEGE, R. M., Sebastopol. Application to license one commercial passenger vehicle with seating capacity for 39 persons to operate between Mannibadar and Ballarat for the carriage of school children under contract to the Education Department.

THEGE, R. M., Sebastopol. Application to license one commercial passenger vehicle with seating capacity 45 persons to operate between Linton and Ballarat for the carriage of school children under contract to the Education Department, and in addition, to carry adult passengers at railway fares by arrangement between the Education Department and the Victorian Railways Board.

THEGE, R. M., Sebastopol. Application to license one commercial passenger vehicle with seating capacity for 39 persons to operate between Scarsdale and Ballarat for the carriage of school children under contract to the Education Department.

TSIOGRIS, G., Clifton Hill. Application to license one commercial passenger vehicle with seating capacity for eleven persons to operate for the carriage of Greek language students as follows: (i) Between the corner of Gilbert Road and Murray Road, Reservoir and the Reservoir East Primary School in Boldrewood Parade. Passengers picked up in the Reservoir area east of High Street.

## TIME-TABLE.

Monday and Thursday between 3 p.m. and 8 p.m.

(ii) Between the corner of Mahoneys Road and High Street, Thomastown and the Thomastown East Primary School in Cedar Street. Passengers picked up in the Thomastown and Loral areas east of High Street.

## TIME-TABLE.

Wednesday between 3 p.m. and 8 p.m.

Saturday between 9 a.m. and 7 p.m.  
(iii) Between the corner of St. Georges Road and Brunswick Street, Fitzroy North and the Clifton Hill Primary School in Spensley Street. Passengers picked up in the Fitzroy North, Fitzroy, Collingwood, Abbotsford and Clifton Hill areas.

## TIME-TABLE.

Tuesday and Friday between 3 p.m. and 8 p.m.

WALKERS, B. M. BUS SERVICE PTY. LTD., Bendigo. Application for variation of all U.O. licence conditions which authorize various route services in Bendigo and various tours from Bendigo to include the ability to operate as follows: (a) From Bendigo to Melbourne for the carriage of passengers to night entertainment centres in the City area and/or Flinders Street Station. (b) From Bendigo to trotting meetings at the Royal Agricultural Showgrounds, Flemington and Moonee Valley Racecourse for the carriage of trotting patrons.

## TIME-TABLE.

As and when required.  
Depart Bendigo 3.00 p.m. to 5.30 p.m.  
Depart Melbourne 11.30 p.m.

Fares.—\$5.00 return.

WARRNAMBOOL BUS LINES PTY. LTD., Warrnambool. Application to license one commercial passenger vehicle with seating capacity for nineteen persons to operate in substitution for but not in addition to vehicles already licensed in the name of the applicant.

NOTE.—This application does not seek charter rights.

WICKHAM, K. G., Wedderburn. Application to license one commercial passenger vehicle with seating capacity for eleven persons to operate between Logan and Bealiba for the carriage of school children only under contract to the Education Department.

Application for renewal of licence as shown by the persons listed hereunder to operate under the same terms and conditions:—

BUCHAN TIMBER COMPANY PTY. LTD., Springvale; S.V.32.  
ELDER SMITH GOLDSBOROUGH, MORT LIMITED, Melbourne; S.V.19.

ESTATE OF THE LATE FLORANCE, J. R., Orbost; S.V.22.  
MILDURA CO-OPERATIVE FRUIT CO. PTY. LTD., Mildura; S.V.17.

D. I. & THE ESTATE OF THE LATE RYAN, M. W., Tullamarine; T.S.199.

WEIGHTMAN, G. J., Serpentine; T.S.433.

Notice of any objections should be forwarded to reach the Secretary of the Board not later than 2nd March, 1977.

Applicants are advised that it will not be necessary to appear on the hearing date specified, unless advised in writing by the Board.

H. SHEAHAN, Secretary.

Corner Lygon and Princes Streets, Carlton, 3053, Wednesday, 16th February, 1977.

Commercial Goods Vehicles Act.  
TRANSPORT REGULATION BOARD.

HEARING OF APPLICATIONS.

Notice is hereby given that the following applications will be considered by the Transport Regulation Board on 2nd March, 1977.

**BENDIGO INVESTMENTS LTD.**, 27 Queen Street, Bendigo, 3550. Two commercial goods vehicles (L/C. 0.95 and 1.00 tonne) to operate throughout the State of Victoria as an "Armoured Vehicle" for the purpose of making special deliveries.

**BONNEY'S PEST CONTROL PTY. LTD.**, (Box 759), 77 Lime Avenue, Mildura, 3500. One commercial goods vehicle (L/C. 0.75 tonne) to operate throughout the State of Victoria in the course of business as "Pest Exterminators"—tools of trade, equipment and materials incidental to own contracts but excluding any operation to or from places within a 40-km radius of the Post Office at the corner of Bourke and Elizabeth Streets, Melbourne.

**BILSTON, L. W.**, Government Road, Arcadia, 3613. One commercial goods vehicle (L/C. 1.55 and 2.00 tonne trailer) to operate within a 160-km radius of own premises at Arcadia in the course of business as "Pipe Laying Contractor"—tools of trade, own equipment, spare parts for on-site servicing of own equipment and not more than 50 kilograms of pipe fittings required for the completion of own contracts, excluding the carriage of spare parts and pipe fittings from places within a 40-km radius of the G.P.O. Melbourne.

**CHASEMORE EXCAVATIONS PTY. LTD.**, 253 Whitehorse Road, Blackburn, 3136. One commercial goods vehicle (L/C. over 13.00 tonne) to operate throughout the State of Victoria in the course of business as "Land Clearing and Excavation Contractor"—own plant and own equipment incidental to own contracts.

**CLEELAND, W. R.**, 12 Royal Avenue, Benalla, 3672. Two commercial goods vehicles (L/C. 14.00 and 13.25 tonne) to operate from forest landings situated within an 80-km radius of the Post Office at Mansfield to sawmills at Mansfield and Benalla—sawmill logs.

**THE COMMONWEALTH PORTLAND CEMENT CO. LTD.**, 568 St. Kilda Road, Melbourne, 3004. One commercial goods vehicle (to be purchased L/C. approximately 20.00 tonne) to operate from the premises of Blue Circle Southern Cement Ltd., Reservoir Road, Waurin Ponds to various consignees situated within a 40-km radius of the G.P.O. Melbourne—bulk cement in a specially constructed tanker vehicle.

**CONCRETE INDUSTRIES (MONIER) LTD.**, Frankston Road, Dandenong, 3175. One commercial goods vehicle (L/C. 12.85 tonne) to operate from the premises of Blue Circle Southern Cement Ltd., Reservoir Road, Waurin Ponds to various consignees situated within a 40-km radius of the G.P.O. Melbourne—bulk cement in a specially constructed tanker vehicle.

**DALLAS INDUSTRIES (Vic.) PTY. LTD.**, 91 Wyndham Street, Shepparton, 3630. One commercial goods vehicle (L/C. 0.75 tonne) to operate within an 80-km radius of own branch premises at Shepparton in the course of business as "Auto Spares Agent and Distributors"—own goods.

NOTE.—That all goods carried on the vehicle shall have been initially consigned by rail to Shepparton.

**DEIPENAU, H. E., PTY. LTD.**, 73 Victoria Street, East Brunswick, 3057. Six commercial goods vehicles (to be purchased) with (L/C. approximately 20.00 tonne each) to operate from the premises of Blue Circle Southern Cement Ltd. at Reservoir Road, Waurin Ponds to consignees situated within a 40-km radius of the G.P.O. Melbourne—bulk cement in specially constructed tanker vehicles.

**EUCLID TRUCKING CO. PTY. LTD.**, 22 Dynon Road, South Kensington, 3031. One commercial goods vehicle (L/C. 1.05 tonne) to operate throughout the State of Victoria for the purpose of servicing and maintaining

own plant and equipment in the course of business as "Earthmoving Contractors"—tools of trade, spare parts and materials incidental to servicing in the field only.

**GREWAR, D. J.**, P.O. Box 332, Healesville, 3777. One commercial goods vehicle (L/C. 12.60 tonne) to operate: (a) From the sawmill of J. Turnbull at Healesville to timber yards and/or building contract sites situated within a 40-km radius from the G.P.O. Melbourne—sawn timber. (b) From the sawmill of J. Turnbull at Healesville to the premises of Smorgan Consolidated Industries Pty. Ltd. at Brooklyn—wood chips.

**HAM, R. D.**, 66 Warrnambool Road, Terang, 3264. Application to vary the conditions of licence No. D.A.64671 (L/C. 9.30 tonne) by deleting "Terang" and adding in lieu "Camperdown".

**HERBERT, G. & D. B.**, Tawonga, 3697. Application to vary the conditions of licence No. DA68899 (L/C. 11.35 tonne) by deleting "Bogong" from paragraph (c) and adding in lieu "Falls Creek".

**HERBERT, G. & D. B.**, Tawonga, 3697. One commercial goods vehicle (L/C. 4.00 tonne) to operate: (a) Within a 40-km radius of own premises at Mt. Beauty—general goods. (b) Within an 80-km radius of own depot at Mt. Beauty—petroleum products in prescribed types of containers and in bulk tanks and own return containers. (c) From and to the township of Wodonga to and from the township of Falls Creek via the townships of Kiewa, Kergunyah, Dederang, Tawonga, Mt. Beauty and Bogong—general goods.

NOTE.—That no goods whatsoever shall be taken up or set down between Kiewa and Dederang both townships inclusive.

**HOLLAND, N. J.**, 11 Chamberlain Street, Ballarat, 3350. One commercial goods vehicle (L/C. 6.30 tonne) to operate within an 80-km radius of Avoca in the course of business as "Fuel Merchant and Fence Post Supplier"—own fence posts and firewood.

**HUTCHINS, D. J.**, 34 Hastings Road, East Hawthorn, 3123. One commercial goods vehicle (L/C. 0.75 tonne) to operate throughout the State of Victoria in the course of business as "Two Way Radio Sales and Service"—tools of trade, two way radios and equipment for specialised installation, spare parts and materials incidental to the on-site servicing, maintenance and installation of such equipment.

**JONKERS, G.**, Orbost, 3888. Application to vary the conditions of licence No. DT1001 (L/C. 16.90 tonne) by deleting the existing paragraph "(e)" and adding in lieu as paragraph (e) "Within that part of the State of Victoria east of the Snowy River to and from Bairnsdale—own logging equipment".

**LOVE, H. E.**, P.O. Box 82, Cobram, 3644. One commercial goods vehicle (L/C. 0.75 tonne) to operate within that part of the State of Victoria bounded on the east by a north/south line drawn through Rutherglen, on the south by an east/west line drawn through Nagambie and on the west by a north/south line drawn through Rochester in the course of business as "Farm Supply and Irrigation Contractor"—agricultural chemicals, fertilizers, irrigation and agricultural equipment; earthmoving equipment and incidental materials required for the installation of irrigation equipment.

**LOVE, H. E.**, Broadway Street, Cobram, 3644. One commercial goods vehicle (L/C. 6.10 tonne) to operate within that part of the State of Victoria bounded on the east by a north/south line drawn through Rutherglen, on the south by an east/west line drawn through Nagambie and on the west by a north/south line drawn through Rochester in the course of business as "Farm Supply and Irrigation Contractor"—agricultural chemicals, fertilizers, irrigation and agricultural equipment, earthmoving equipment and incidental materials required for the installation of irrigation equipment.

**LYONS, K. R.**, Fairbairns Road, Yinnar, 3869. Application to vary the conditions of licence numbered TDA64415/1 and TDA64415/2 (L/C. 2.55 and 1.40 tonne trailer, 6.75 and 1.30 tonne trailer) by adding an additional paragraph (g) from Ramsay Fibreglass at Bayswater to Stephenson at Moe—fibreglass boat hulls.

**MAUDE, J. W.**, Northern Highway, Tooborac, 3604. One commercial goods vehicle (L/C. 0.40 and 0.20 tonne trailer) to operate: (a) From Melbourne and Bendigo to own premises at Tooborac in the course of business as "General Store Keeper"—own goods. (b) Within 25-km of Tooborac—own groceries and mail under contract to the Australian Postal Commission.

**MULLINS, W. C.**, 6 Linlithgow Way, Melton, 3337. One commercial goods vehicle (L/C. 7.40 tonne) to operate within an 80-km radius of the premises of

- Cadbury Schweppes Pty. Ltd. at Tullamarine solely on behalf of the said company as an "Exclusive Contractor"—aerated waters and empty return containers.
- MCKINNON, H. J., P.O. Box 277, Warrnambool, 3280. One commercial goods vehicle (L/C. 16.00 tonne) to operate: (a) Within a 40-km radius of the post office at Warrnambool—general goods. (b) From Ponting Bros. Timber (Distribution) Pty. Ltd. Sawmill at Portland, M. R. Benbow & Co. Sawmill at Heywood, Gavin Rowe and Co. Pty. Ltd. Sawmill at Heathmere and Porters Sawmill at Ettrick to the timber yards of Ponting Bros. Pty. Ltd. and Fotheringham Bros. Pty. Ltd. at Warrnambool—sawn timber.
- NASH, J. S., Station Street, Corio, 3214. Two commercial goods vehicles (to be purchased with L/C. approx. 20.00 tonne each) to operate from the premises of Blue Circle Southern Cement Ltd. at Reservoir Road, Waurm Ponds to various consignees situated within a 40-km radius of the G.P.O. Melbourne—bulk cement in specially constructed tanker vehicles.
- O'KEEFE, M., 21 Campbell Crescent, Balnarring, 3962. Application to vary the conditions of licence No. D.A.68684/1 and D.A.68684/2 (L/C. 15.00 tonne each) by deleting "Throughout the State of Victoria" and adding in lieu "within an 80-km radius of Balnarring".
- PETHARD INSULATIONS PTY. LTD., 84 Stephenson Street, Richmond, 3121. One commercial goods vehicle (L/C. 0.75 tonne) to operate: (a) Within an 80-km radius of own premises at Richmond in the course of business as "Insulation Manufacturers"—own goods. (b) From own premises at Richmond to own premises at Traralgon (an approved decentralized secondary industry Metal Fabrication)—raw materials and partly processed products for use in the manufacturing processes of such industry. (c) From such industry at Traralgon to places within an 80-km radius thereof and to own premises at Richmond—manufactured products from the approved decentralized secondary industry.
- PITTS, T. E., 47 Bridge Street, West Benalla, 3672. One commercial goods vehicle (L/C. 7.95 tonne) to operate: (a) Within an 80-km radius from the post office at Benalla—plant the property of a contractor and required by him for use in connection with the construction or maintenance of some specific, existing or proposed road, street, footpath, bridge, pier, wharf, weir or channel and also the following materials, viz.—metal, stones, screenings, ashes, gravel, sand and earth. (b) Within a 32-km radius from the site of any construction or maintenance work performed pursuant to paragraph (a) above, or from the railway station nearest thereto—any other materials required for such work. (c) Within a 40-km radius of the post office at Benalla—general goods.
- RALLS, T. W., 67 Contingent Street, Trafalgar, 3824. One commercial goods vehicle (L/C. 10.60 and 10.00 tonne trailer) to operate: (a) From the premises of Albion Reid Pty. Ltd. at Morwell to consignees situated within an 80-km radius of the post office at Morwell and to places within the Shires of Bairnsdale and Tambo—hot asphalt and pre-mix. (b) From Avon Quarries Pty. Ltd. at Stratford to consignees situated within an 80-km radius of the post office at Traralgon—river pebbles and stones and top soil.
- ROOSJE, P. A., 32 Roxby Street, Manifold Heights, 3218. Application to vary the conditions of licence No. D.A.68155 (L/C. 1.60 tonne) by adding an additional paragraph (b) "From the premises of R. & M. Van Wegen Pty. Ltd. Warrnambool to the premises of Koroit Photographic Store at Koroit—bread."
- ROSSIGNOLI, A. P., 5 McGlane Street, Mitcham, 3132. One commercial goods vehicle (L/C. 0.70 and 2.15 tonne trailer) to operate: (a) Within an 80-km radius of own premises at Mitcham in course of business as "Demolition Contractor"—own goods. (b) Throughout the State of Victoria in the course of business as "Demolition Contractor"—own tools of trade and own equipment. (c) Within a 40-km radius of the site of any current contract—materials required for use on such contract and materials for disposal.
- SCHILKE, W., 6 Lantana Court, Wantirna, 3152. One commercial goods vehicle (L/C. 16.00 tonne) to operate: (a) Within a 40-km radius of own premises at Wantirna in the course of business as "Soil, Screening and Garden Supply"—own goods. (b) From Seymour and Yea to own premises at Wantirna—own river pebbles. (c) From Pirron Yallock, Bacchus Marsh and Rockbank to own premises at Wantirna—own rock. (d) From Toolangi to own premises at Wantirna—own mountain soil.
- T.M.S. PTY. LTD., 33 Gillies Street, Benalla, 3672. One commercial goods vehicle (L/C. 2.75 tonne) to operate: (a) Throughout the State of Victoria in the course of business as "Agricultural Spraying Contractors"—tools of trade, spraying equipment and a quantity not exceeding 500 kg at any one time of chemicals for spraying purposes, provided that no chemicals shall be carried from the Metropolitan Area (as defined in the *Transport Regulation Act 1958*) and further provided that all chemicals carried shall have been initially consigned by rail to the Benalla Railway Station. (b) Throughout the State of Victoria in the course of business as "Turf Maintenance Experts"—tools of trade, equipment and materials not exceeding 500 kg on any one trip required for the completion of own contracts provided that no materials shall be carried from places within a 40-km radius of the G.P.O. Melbourne.
- TRANS WEST HAULAGE PTY. LTD., 202 Station Street, Norlane, 3214. Application to vary the conditions of licence No. D.A.65323/80 (L/C. 15.95 tonne) by adding two additional paragraphs (f) and (g)—(f) From the premises of Pilkington A.C.I. Operations Pty. Ltd. at Geelong solely on behalf of the said company to the premises of Potters Industries Pty. Ltd. at Brooklyn and the premises of A.C.I. at Dandenong—scrap and broken glass. (g) Within a 40-km radius of the G.P.O. Melbourne—scrap and broken glass.
- TRIGAR, V., 36 Collins Street, West Heidelberg, 3081. One commercial goods vehicle (L/C. 5.50 tonne) to operate within a 112-km radius of the City Brick Works Co. at Tooronga solely on behalf of the said company—bricks.
- THE VICTORIA PORTLAND CEMENT CO. LTD., 568 St. Kilda Road, Melbourne, 3004. Three commercial goods vehicles (to be purchased) (L/C. approximately 20.00 tonne) to operate from the premises of Blue Circle Southern Cement Ltd., Reservoir Road, Waurm Ponds to various consignees situated within a 40-km radius of the G.P.O. Melbourne—bulk cement in specially constructed tanker vehicles.
- WAKEFIELD, R. J., Box 160, Merbein, 3505. One commercial goods vehicle (L/C. 18.30 tonne) to operate: (a) From the premises of Mildara Wines Pty. Ltd. at Merbein an approved decentralized secondary industry (winery) to Melbourne solely on behalf of the said company—bulk and packaged wines and spirits from the said industry. (b) From Melbourne to the premises of Mildara Wines Pty. Ltd. at Merbein an approved decentralized secondary industry (winery)—empty return pallets, containers, packaging materials and raw materials for use solely in the manufacturing processes of such industry.
- WHEATER, B. M. M. L., 545 Napier Street, Bendigo, 3550. One commercial goods vehicle (L/C. 0.40 tonne) to operate: (a) Within a 40-km radius of the chief post office at Bendigo—general goods. (b) From Bendigo to Elmore, Redesdale, Heathcote, Kyneton, Malmesbury, Castlemaine, Maryborough, Goornong, Toolleen, Tara-dale, Chewton, Newstead, Elphinston and places en route—newspapers on behalf of the Bendigo Advertiser.
- WILLIS, P. R., 34 Silverton Drive, Noble Park, 3174. One commercial goods vehicle (L/C. 7.00 tonne) to operate within an 80-km radius of the premises of Brick and Pipe Industries Pty. Ltd. at Auburn on behalf of the said company—bricks.
- WILTSHIRE, P. C., Quarry Road, Waurm Ponds, 3221. One commercial goods vehicle (to be purchased) (L/C. approximately 17.50 tonne) to operate from the premises of Blue Circle Southern Cement Ltd. Reservoir Road, Waurm Ponds to various consignees situated within a 40-km radius of the G.P.O. Melbourne—bulk cement in specially constructed tanker vehicle.

## TOW TRUCKS.

- HADLEY, G. R., 73-75 Greta Road, Wangaratta, 3677. One commercial goods vehicle (tilt tray to be purchased) (L/C. 3.00 tonne) to operate throughout the State of Victoria as a tow truck: (a) For the purpose of lifting and carrying or towing of wrecked or disabled motor vehicles and the carriage of tools and equipment necessary for such purposes. (b) The carriage of spare parts necessary for the repair of a disabled motor vehicle to and from the place at which such disablement has occurred.
- DEUTSCH, J. S. & G. P. (trading as Lancefield Motors), Lancefield, 3435. Application to vary the conditions of licence No. D.A.64138 (L/C. 3.65 tonne) by deleting "80-km radius" and adding in lieu "Throughout the State of Victoria":

## RENEWALS.

Applications for renewal of licences as shown by persons listed hereunder to operate under the same terms and conditions from the expiry shown in each case.

ARNOLD, G. H. C., P.O. Box 237, Benalla, 3672; D.A.39609/4; 16th December, 1976; 3.00 tonne.  
CAMERON, B. R., Patterson Road, Clyde, 3978; T.D.A.68267; 5th February, 1977; 5.70 tonne and 3.00 tonne trailer.  
GURRIE, V. J., 2 Walker Street, Anglesea, 3230; D.A.60870/1; 17th March, 1977; 350 tonne.  
HAYLOCK, E. L., 75 Gipps Street, Port Fairy, 3284; D.A.8875/9; 26th March, 1977; 5.55 tonne.  
LEVINGSTON, ADVERTISING PTY. LTD., 17 Yarra Street, South Yarra, 3141; D.A.62683/3; 17th March, 1977; 0.50 tonne.  
PHILLIPS, G. R., 37-41 Spicer Street, Beaumaris, 3193; D.A.44075/6; 14th December, 1976; 1.00 tonne.  
PICKERING, R., 17 Beswick Street, Garfield, 3814; T.D.A.68285; 23rd February, 1977; 13.35 tonne.  
SMITS, B. W. & SON PTY. LTD., 49 Emily Street, Seymour, 3660; D.A.61865/1; 26th March, 1977; 0.60 tonne.  
THOMAS, R. W., Newlyn Park, Macarthur, 3286; D.A.63841/1; 26th March, 1977; 11.00 tonne.  
TREVOR BOILER & ENG. CO. PTY. LTD., Steel Street, North Melbourne, 3051; D.A.28850/4; 21st December, 1976; 3.55 tonne.  
WESTBURY, N. J., Forest Street, Colac, 3250; D.A.53580/1; 1st March, 1977; 9.90 tonne.

## TOW TRUCKS.

ARNOLD, G. H. C., Shepparton Road, Benalla, 3672; T.D.A.39609/6; 23rd December, 1976; 3.50 tonne.  
BROWN, K. J. (trading as Brown's Motors & Body Works), 148 Murray Valley Highway, Echuca, 3625; D.A.47663; 26th February, 1977; 3.80 tonne.  
CARPENTER, C. N., 38 Mologa Road, West Heidelberg, 3081; D.A.64294; 14th March, 1977; 2.05 tonne.  
DANDENONG PANELS PTY. LTD., 10 Gladstone Road, Dandenong, 3124; D.A.65821/2; 20th March, 1977; 2.05 tonne.

Notice of any objection should be forwarded to reach the Secretary of the Board not later than 22nd February, 1977.

Applicants are advised that it will not be necessary to appear on the hearing date specified above, unless advised in writing by the Board.

H. SHEAHAN, Secretary.

Corner ' Lygon and Princes Streets, Carlton, 3053, Wednesday, 16th February, 1977.

## COMPANIES ACT 1961.

Notice is hereby given that in pursuance of section 308 (4) of the Companies Act 1961 the names of the Companies referred to below have been struck off the Register and on publication of this Notice in the Government Gazette the said Companies will be dissolved.

Dated this 9th day of February, 1977.

E. B. MITCHAM,

Deputy Commissioner for Corporate Affairs.

Corporate Affairs Office,  
Melbourne.

## COMPANIES ABOVE REFERRED TO.

Name of Company.	Number of Registration.
The Federal Manufacturing Company Proprietary Limited	C6019F
Marchant Opticians Proprietary Limited	C14499A
W. Retlaw Pty. Limited	C18523A
L. C. Cooke Proprietary Limited	C23336Y
John Milton Proprietary Limited	C24374P
Mannequin Modes Proprietary Limited	C24540G
Pingelly Proprietary Limited	C24541J
Glenbro Investments Pty. Ltd.	C27772E
Kedron Pty. Limited	C28285V
Hamilton Fashion-Centre Proprietary Limited	C28849Y
Gimbels Pty. Limited	C29378L
Eddy's Provision Stores Proprietary Limited	C30140S
L. V. Haack Motors Proprietary Limited	C32525H
Taree Proprietary Limited	C32673A
Tantalum Mines Development Pty. Ltd.	C33224X
Specialised Contract Drafting Services Pty. Ltd.	C34463B
I. N. Iversen & Company Pty. Limited	C35231J
Helm Estates Proprietary Limited	C35313M
Ararat Quarries & Readymix Pty. Ltd.	C35863F
Myamyn Pty. Ltd.	C40333T
Scenic Development Proprietary Limited	C40680U
Langford Properties Proprietary Limited	C41372L

Name of Company.	Number of Registration.
Istol Pty. Limited	C42316H
Northern Properties (Sydenham) Proprietary Limited	C42417R
Automotive Promotions Proprietary Limited	C45220R
Sharequest Pty. Ltd.	C45490Z
Tasmanian Exhibitions Proprietary Limited	C46565N
Truscotts (Victoria) Pty. Limited	C46717M
Barnes Bus Lines Proprietary Limited	C47101W
Barnes Coaches (Sunshine) Proprietary Limited	C47102Y
Fabtex (Holdings) Proprietary Limited	C48814B
Middleborough Estates Pty. Limited	C49519D
Vinewoods Proprietary Limited	C49582L
Page Holdings Proprietary Limited	C49883K
A.D.M. Development Consultants (Australia) Pty. Limited	C50321X
R. Shanks Trading Pty. Limited	C50587R
Foster Publishing Pty. Limited	C50665K
Basset Investments Pty. Limited	C51188D
Airlie Mercantile Agency Proprietary Limited	C51950V
Kearney, Watts & Son Proprietary Limited	C52494X
Case Duncan and Sons Pty. Limited	C54612T
Watt's Butchers Pty. Limited	C55189L
Sattar Investment Company Pty. Limited	C55574U
C. T. & H. Constructions Proprietary Limited	C55872F
Bussey Trading Co. Proprietary Limited	C56561S
Gem Films Proprietary Limited	C56655C
Mindex Proprietary Limited	C56983Z
Lanack Engineering Co. Pty. Ltd.	C57799M
Louant Pty. Ltd.	C57827R
Rushford Home Furnishers Pty. Ltd.	C57914L
Burnett Rural Traders Proprietary Limited	C59881M
Taffys Proprietary Limited	C60002N
Artaco Proprietary Limited	C61341Y
Victorian Wool & Sheepskins Proprietary Limited	C61526N
Ed'rose Accessories Proprietary Limited	C62008S
Tank Truck Trailers Pty. Ltd.	C62495L
Contura Industries Pty. Ltd.	C62986M
Miszelle Fashions Proprietary Limited	C63288L
Zepelle Fashions Proprietary Limited	C63289N
Katlyn Fashions Proprietary Limited	C63301A
Ladd Finance Pty. Ltd.	C63949N
The Auto Centre (Cheltenham) Proprietary Limited	C64568D
H. S. Trigg & Associates Pty. Ltd.	C64638Z
J. R. Druce Industries Pty. Limited	C66011K
Datec Australia Pty. Ltd.	C66265W
G. R. Morton & Co. Pty. Ltd.	C66360R
Neil Hill T.V. Pty. Ltd.	C66391C
Millennium Multi-Branch Pty. Limited	C67619T
Noel James Proprietary Limited	C67881J
Harkob Pty. Limited	C68666K
Linkmaster Proprietary Limited	C68759U
Lambert & Morrissey Constructions Pty. Limited	C69000C
Accommodation & Catering Trade Centres Pty. Ltd.	C70215W
R. S. Amusements Pty. Ltd.	C71055F
Two City Motor Inn Pty. Limited	C72070J
Saber Productions Proprietary Limited	C79768P
J.E.S. Investments Pty. Limited	C80997B
Tran-Span Pty. Ltd.	C82881V
Torr Engineering (Australia) Proprietary Limited	C82923K
Capricorn Knitwear (International) Proprietary Limited	C83020M
Smoke Watchers of Australia Pty. Ltd.	C83560C
Bel-Ex Industries Pty. Limited	C87003T
Western Design Centre Pty. Limited	C89866C
Western Drafting Centre Pty. Limited	C89867E
United Forest Products Corporation Pty. Ltd.	C90424G
Koopamar Land Corporation Pty. Ltd.	C91320A
U.F.P. (Management) Pty. Ltd.	C91421H
Godfrey-Browne Constructions Pty. Ltd.	C91981E
H.S.S. Investments Pty. Limited	C92465M
Hydrosun Pty. Limited	C93063U
Senjur Pty. Ltd.	C93069G
Gunn's Restaurant Pty. Ltd.	C96213L
J. D. Thomas Pty. Ltd.	C97032M
S. F. & H. M. McLean Pty. Ltd.	C99461G
Louis Electrical and Home Furnishing Pty. Limited	C99951F
Mr. Bargain Pty. Ltd.	C102959B
Aluframe Pty. Ltd.	C104739Z
Ledvi (Import-Export) Proprietary Limited	C105589M
Ledwij Transport Proprietary Limited	C105590W
Adrian Gray & Associates (Window Cleaning) Pty. Ltd.	C106743E
Australian Iran Trading Co. Pty. Ltd.	C106949D
De Jager Constructions Proprietary Limited	C107146L
Bernard Pools Pty. Ltd.	C107390A
Bokhara House Proprietary Limited	C107463C

## COMMONWEALTH OF AUSTRALIA.

Petroleum (Submerged Lands) Act 1967.

## STATE OF VICTORIA.

Petroleum (Submerged Lands) Act 1967.

## PROHIBITION OF ENTRY INTO SAFETY ZONE—TUNA PLATFORM.

I, James Charles Murray Balfour, Minister of Mines for the State of Victoria, the Designated Authority in respect of the area specified as being adjacent to the State of Victoria, under the provisions of section 119 of the Act hereby prohibit from entering into or remaining in, except with my consent in writing, the area of the safety zone described hereunder, all vessels other than vessels engaged in or in connexion with petroleum exploration operations or operations for the recovery of petroleum authorized by me in the area concerned.

## DESCRIPTION OF AREA OF SAFETY ZONE.

The area which extends to a distance of five hundred metres measured from each point of the structure known as the Tuna platform situated at or about the point of latitude 38 deg. 10 min. 16.7 sec. South, longitude 148 deg. 25 min. 6.4 sec. East.

Dated this 7th day of February, 1977.

Made under the Petroleum (Submerged Lands) Act 1967 of the Commonwealth of Australia.

Made under the Petroleum (Submerged Lands) Act 1967 of the State of Victoria.

JIM BALFOUR,  
Designated Authority.

## ERRATUM.

In *Victoria Government Gazette*, No. 8, dated 9th February, 1977, on pages 349, 350 and 351 in Notices published under the heading, "Town and Country Planning Act 1961", where the date "2nd February, 1976" appears, substitute the date "2nd February, 1977".

## ERRATUM.

In *Government Gazette* No. 5 of 2nd February, 1977, on page 257, under "APPOINTMENTS," the name of the appointee to the position of Inspector of Treatment Centres, Alcoholics and Drug Dependent Services Branch, Department of Health, should read "KEITH MCLEOD BENN, M.B., B.S."

## MINES DEPARTMENT.

## APPLICATION FOR EXTRACTIVE INDUSTRY LICENCE DECLARED ABANDONED.

No. 797; Viscount Holdings Ltd.; 74 ha, Parish of Wodonga.

## EXTRACTIVE INDUSTRY LICENCES GRANTED.

No. 712; Western Sand & Stone Pty. Ltd.; 8.5 ha, Parishes of Coimadai and Merrimu.

No. 791; James Alfred Hammill; 7.5 ha, Parish of Warragul.

No. 848; Patrick Thomas Grist, Joan Grist, Gary Patrick Grist, Duncan John McNaughton; 1.2 ha, Parish of Warrion.

## EXTRACTIVE INDUSTRY LICENCE SURRENDERED.

No. 100; Kolor Clays Proprietary Limited; 10.9 ha, Parish of Yuroke.

J. C. M. BALFOUR,  
Minister of Mines.

*Police Offences Act 1958*, No. 6337.

## DIVISION 1A.—STATE ADVISORY BOARD ON PUBLICATIONS.

Whereas I have considered reports made to me by the State Advisory Board on Publications under section 180b (2) (a) of the *Police Offences Act*:

I, Vance Oakley Dickie, Chief Secretary of Victoria, in pursuance of the power vested in me by section 180h (1) of the *Police Offences Act* hereby determine that the following publications prescribed by title in the schedule hereunder shall be classified as restricted publications for the purposes of the abovementioned Act.

## SCHEDULE OF PUBLICATIONS.

Title.	Distributor.
A Time For Loving.	Melbourne Wholesale News-agency Pty. Ltd.
Banana Split Vol. 1 No. 1.	Claredale Trading Pty. Ltd.
Bawdy No. 13.	W. J. Horne.
Beaver—February 1977.	Kennard International Pty. Ltd.
Blue Book Vol. 1 No. 1.	Claredale Trading Pty. Ltd.
Body Language No. 4.	Kennard International Pty. Ltd.

Title.	Distributor.
Broads From Abroad No. 4.	Kennard International Pty. Ltd.
Cannon Balls No. 4.	Kennard International Pty. Ltd.
Climax No. 21.	Claredale Trading Pty. Ltd.
Club International Vol. 5 No. 11.	Kennard International Pty. Ltd.
Cocksure No. 82.	Towart Distribution Co. Pty. Limited.
Dirty No. 14.	Melbourne Wholesale News-agency Pty. Ltd.
Game Vol. 3 No. 8.	Kennard International Pty. Ltd.
Genesis—January 1977.	Kennard International Pty. Ltd.
Hard Core No. 47.	Towart Distribution Co. Pty. Limited.
Kings Cross Whisper No. 236.	Towart Distribution Co. Pty. Limited.
Lickety Splits Vol. 2 No. 1.	Kennard International Pty. Ltd.
Loving Cups Vol. 2 No. 2.	Kennard International Pty. Ltd.
Men Only Vol. 41 No. 8.	Kennard International Pty. Ltd.
National News Nos. 3 & 4.	Claredale Trading Pty. Ltd.
New MS No. 1.	Claredale Trading Pty. Ltd.
New MS No. 6.	Claredale Trading Pty. Ltd.
Park Lane No. 13.	Claredale Trading Pty. Ltd.
Park Lane No. 16.	Claredale Trading Pty. Ltd.
Play-Pen Vol. 1 Nos. 1 & 2.	Claredale Trading Pty. Ltd.
Playbirds Vol. 1 Nos. 5 & 6.	Claredale Trading Pty. Ltd.
Playbirds Vol. 1 No. 9.	Claredale Trading Pty. Ltd.
Pleasure No. 3.	Melbourne Wholesale News-agency Pty. Ltd.
Pleasure No. 159.	Towart Distribution Co. Pty. Limited.
Private No. 33.	Claredale Trading Pty. Ltd.
Pub—January 1977.	Kennard International Pty. Ltd.
Pussy Brats No. 6.	Kennard International Pty. Ltd.
Ribald Nos. 219 & 220.	W. J. Horne.
Rough Riders Vol. 2 No. 1.	Kennard International Pty. Ltd.
Schoolgirl Seduction No. 2.	Claredale Trading Pty. Ltd.
Searchlight Nos. 194 & 195.	Melbourne Wholesale News-agency Pty. Ltd.
Sexy Swingers Nos. 207 & 208.	Towart Distribution Co. Pty. Limited.
Sheer Delight No. 6.	Kennard International Pty. Ltd.
Superséx No. 7.	Claredale Trading Pty. Ltd.
Supersex No. 10.	Claredale Trading Pty. Ltd.
Swank—January 1977.	Kennard International Pty. Ltd.
Tender Teens No. 4.	Kennard International Pty. Ltd.
The Love Arts.	Melbourne Wholesale News-agency Pty. Ltd.
Weekend Sex No. 18.	Claredale Trading Pty. Ltd.
Weekend Sex No. 21.	Claredale Trading Pty. Ltd.
What A Trip.	Melbourne Wholesale News-agency Pty. Ltd.
Whitehouse No. 16.	Claredale Trading Pty. Ltd.

VANCE DICKIE,  
Chief Secretary.

Chief Secretary's Office,  
Melbourne, 15th February, 1977.

*Private Agents Act 1966.*

## NOTICE OF RECEIPT OF APPLICATIONS FOR LICENCES UNDER THE PROVISIONS OF THE PRIVATE AGENTS ACT 1966.

The Clerk(s) of the Magistrates' Court(s) as listed hereunder hereby give notice that applications, as under, have been lodged for hearing by the said Court(s) on the date(s) specified.

Any person desiring to object to any of such applications must—

- (a) lodge with the respective Clerk of the Magistrates' Court a notice in the prescribed form of his objection and of the grounds thereof;
- (b) cause a copy of such notice to be served personally or by post upon the applicant at least three days before the hearing of the application; and
- (c) send or deliver—
  - (i) where the objection is not made by the officer in charge of the police district in which the Court is situated— a copy of the notice to such officer; and
  - (ii) where the objection is not made by the Registrar or Deputy Registrar—a copy to the Registrar.

Full Name of Applicant or in the Case of a Firm or Corporation, of the Nominee.	Place of Abode of Applicant or Nominee.	Name of Firm or Corporation.	Address for Registration.	Type of Licence.	Date of Hearing of Application
MAGISTRATES' COURT, BROADMEADOWS.					
Sculli, Giuseppe	24 Swan Street, Keilor Park		24 Swan Street, Keilor Park	Watchman	7.3.77
Dated at Broadmeadows this 7th day of February, 1977.					
J. DENAHY, Clerk of the Magistrates' Court.					
MAGISTRATES' COURT, NUMURKAH.					
Girgenti, Angelo	2 Bitcon Numurkah Place,		2 Bitcon Place, Numurkah	Process Server	17.3.77
Dated at Numurkah this 7th day of February, 1977.					
J. L. COLLINS, Clerk of the Magistrates' Court.					
MAGISTRATES' COURT, PORT MELBOURNE.					
Maybourne, Daryl Graeme	1 Foote Street, Albert Park	Mayne Nickless Limited	117 Dow Street, Port Melbourne	Watchman	29.3.77
Dated at Port Melbourne this 7th day of February, 1977.					
J. ARDLIE, Clerk of the Magistrates' Court.					
MAGISTRATES' COURT, MALVERN.					
Waddington, John	324 North Road, East Brighton		659 Dandenong Road, Malvern	Watchman	7.3.77
Dated at Malvern this 7th day of February, 1977.					
M. F. MOLONEY, Clerk of the Magistrates' Court.					
MAGISTRATES' COURT, DANDENONG.					
Beard, Raymond Keith	122A Athol Road, Springvale South		46 Alfred Street, Noble Park	Process Server	28.2.77
Blades, Terrence Alan	23 Arena Square, Noble Park		23 Arena Square, Noble Park	" "	" "
Dated at Dandenong this 7th day of February, 1977.					
P. J. RODDA, Clerk of the Magistrates' Court.					
MAGISTRATES' COURT, HEIDELBERG.					
Morgan, Joy Edith Maree	41 Judith Street, Bundoora		41 Judith Street, Bundoora	Process Server (Individual)	11.3.77
Dated at Heidelberg this 9th day of February, 1977.					
G. G. WILLIAMSON, Clerk of the Magistrates' Court.					
MAGISTRATES' COURT, PRESTON.					
Russell, John William	16 Vasey Avenue, Lalor		16 Vasey Avenue, Lalor	Process Server	8.3.77
Hall, Peter Anthony Patrick	56 Whitelaw Street, Reservoir		58 Whitelaw Street, Reservoir	Watchman	" "
Dated at Preston this 9th day of February, 1977.					
A. SPENCER, Clerk of the Magistrates' Court.					
MAGISTRATES' COURT, FERNTREE GULLY.					
Elliott, Reginal Charles Henry	2 Thornley Close, Ferntree Gully		2 Thornley Close, Ferntree Gully	Process Server	9.3.77
Dated at Ferntree Gully this 9th day of February, 1977.					
T. BEDOHAZY, Clerk of the Magistrates' Court.					
MAGISTRATES' COURT, SPRINGVALE.					
Kouchakdjian, Anthony	160 Haverback Drive, Mulgrave	Kouchak	160 Haverback Drive, Mulgrave	Process Server	9.3.77
Dated at Springvale this 9th day of February, 1977.					
D. D. REES, Clerk of the Magistrates' Court.					
MAGISTRATES' COURT, MELBOURNE.					
Youssof, Mohssen Yehia	7/25 Brixton Street, Flemington	Downard Security Pty. Ltd.	509 Queensberry Street, North Melbourne	Watchman	23.3.77
Dated at Melbourne this 9th day of February, 1977.					
B. M. GILLMAN, Clerk of the Magistrates' Court.					
MAGISTRATES' COURT, PRAHRAN.					
Webster, Barrie James	81 Bayview Street, Prahran		81 Bayview Street, Prahran	Process Server	4.3.77
Dated at Prahran this 10th day of February, 1977.					
G. A. SHARKEY, Clerk of the Magistrates' Court.					





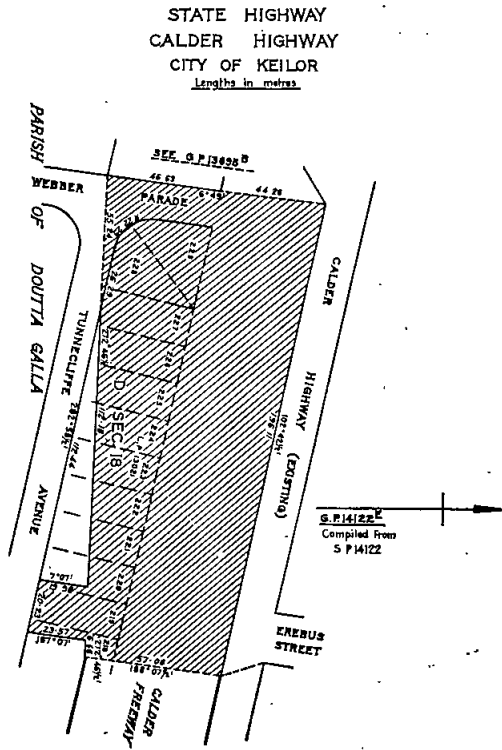
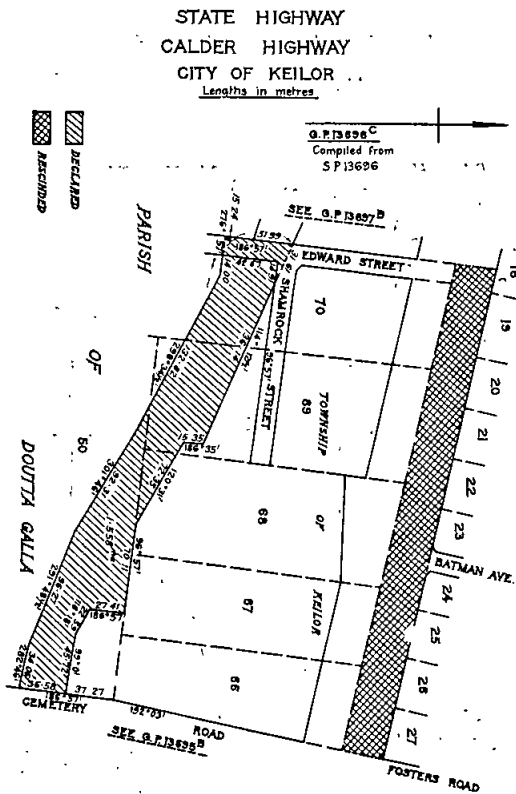

Main Roads.

Resolution dated the First day of February, One thousand nine hundred and seventy-seven, made pursuant to sections 21 of the Country Roads Act 1958 declaring the widening of the Heidelberg-Kinglake Road in the Shire of Eltham as shown hatched on plan numbered G.P.10124 hereunder to be part of a main road within the meaning and for the purposes of the said Act.

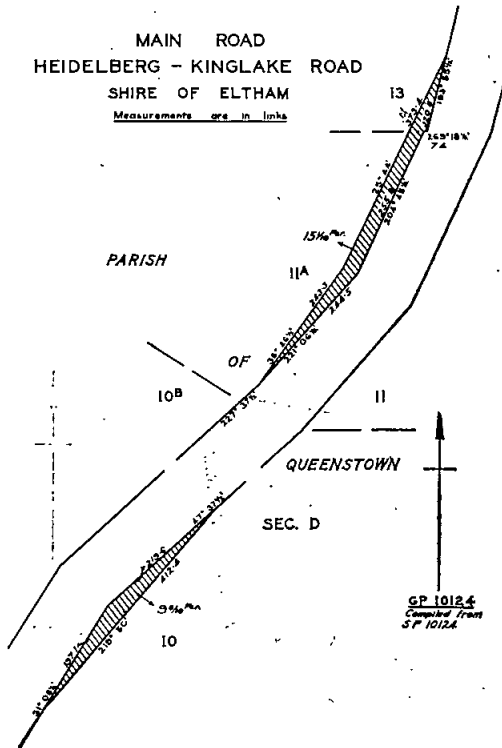
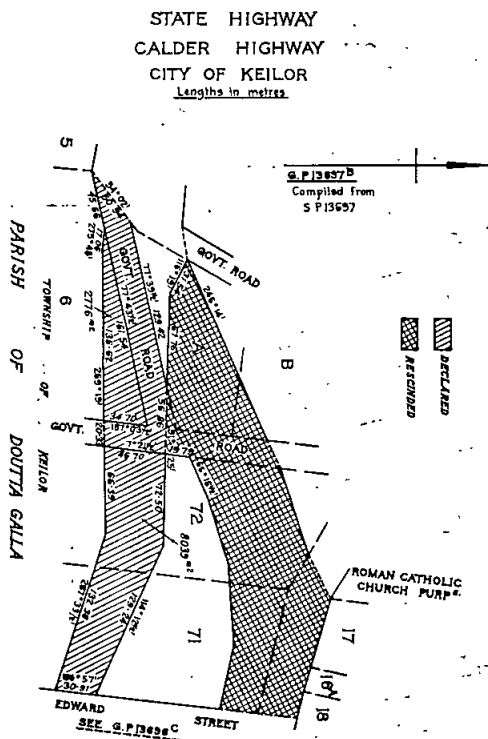

Resolution dated the First day of February, One thousand nine hundred and seventy-seven, made pursuant to section 21 of the *Country Roads Act 1958* declaring the widening of the Ballarat-Maryborough Road in the Shire of Tullaroop as shown hatched on plan numbered G.P.13291 hereunder to be part of a main road within the meaning and for the purposes of the said Act.

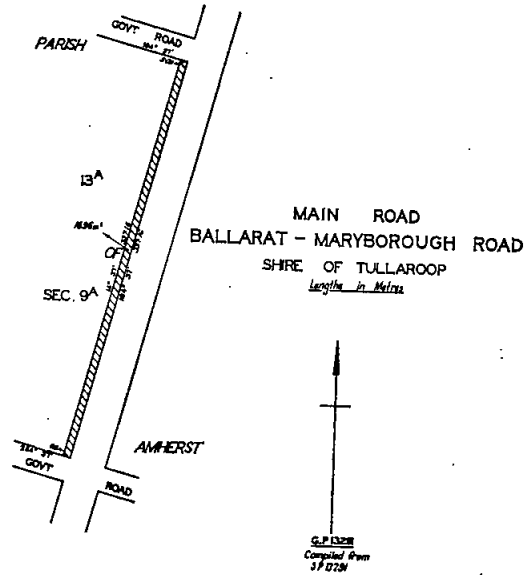

**Freeway.**

Resolution dated the First day of February, One thousand nine hundred and seventy-seven, made pursuant to sections 21 and 101 of the *Country Roads Act 1958* declaring the road in the City of Waverley as shown hatched on plans numbered G.P.14365A and G.P.14365B hereunder to be a freeway (Mulgrave Freeway) within the meaning and for the purposes of the said Act.

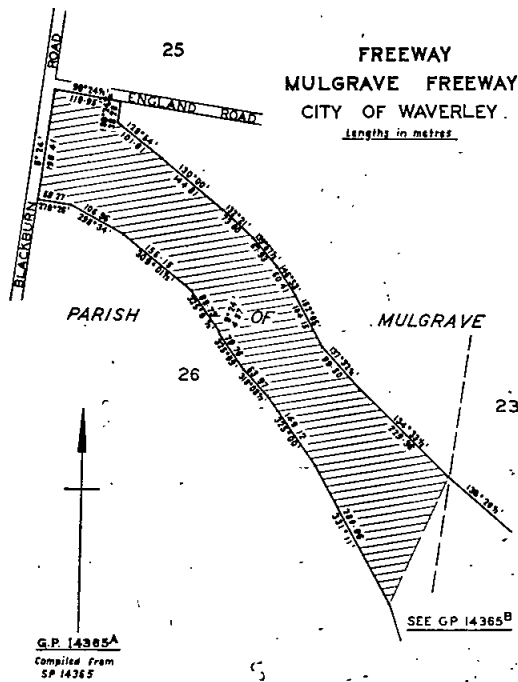
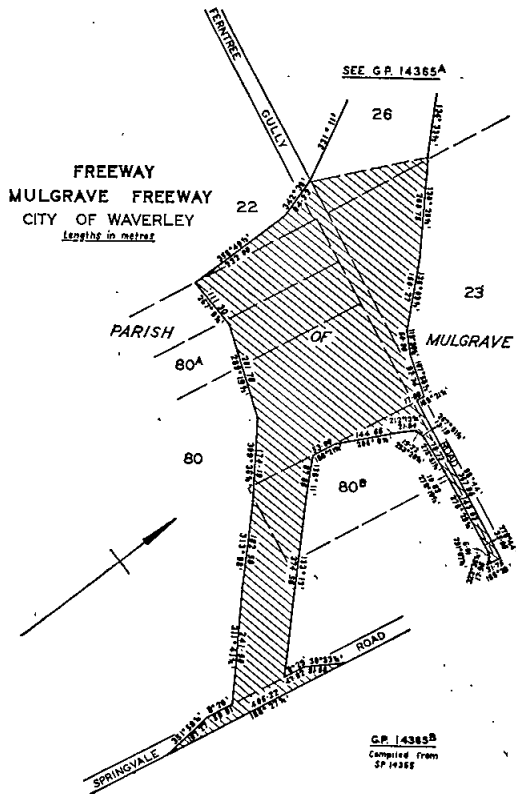

**Unclassified Roads.**

Resolution dated the First day of February, One thousand nine hundred and seventy-seven, made pursuant to sections 21, 58 and 110 of the *Country Roads Act 1958* declaring the deviation from the road in the City of Keilor as indicated by diagonal hatching on plan numbered G.P.13695c hereunder to be part of a road within the meaning and for the purposes of the said Act, and also declaring that such deviation shall be in lieu of the existing road or part thereof indicated by cross-hatching on the said plan and that such part of the said existing road shall be discontinued.

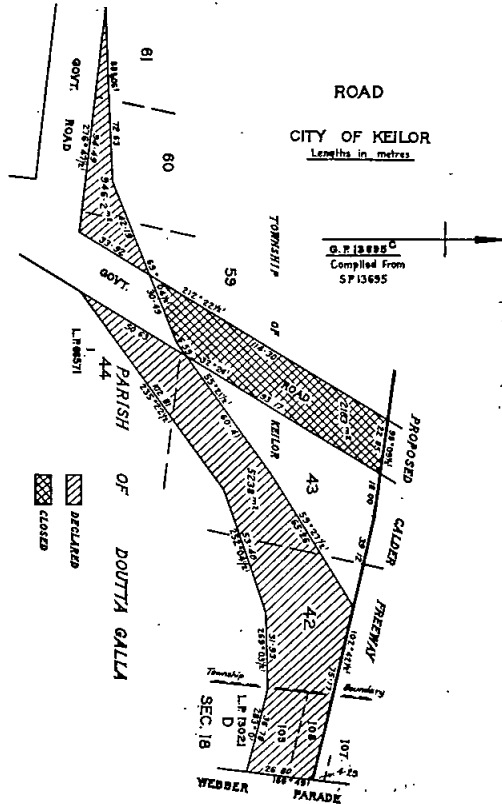

Resolution dated the First day of February, One thousand nine hundred and seventy-seven, made pursuant to sections 21 and 110 of the Country Roads Act 1958 declaring the road in the City of Keilor as shown hatched on plans numbered G.P.13696B and G.P.13698 hereunder to be a road (Fosters Road) within the meaning and for the purposes of the said Act.

ROAD  
FOSTERS ROAD  
CITY OF KEILOR

Lengths in Metres

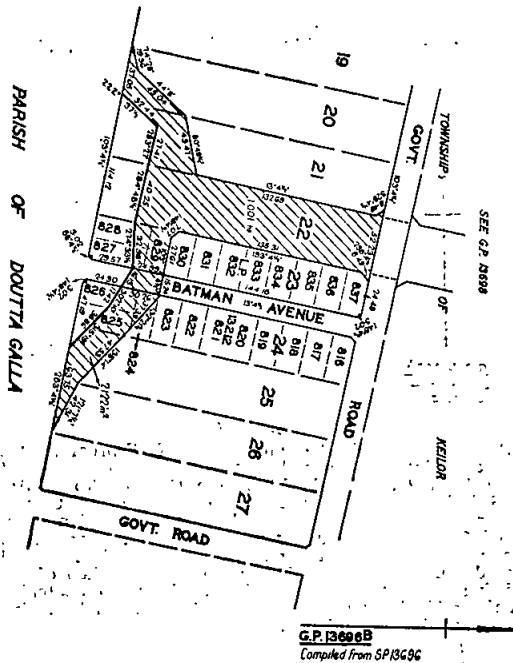

ROAD  
FOSTERS ROAD  
CITY OF KEILOR

Lengths in Metres

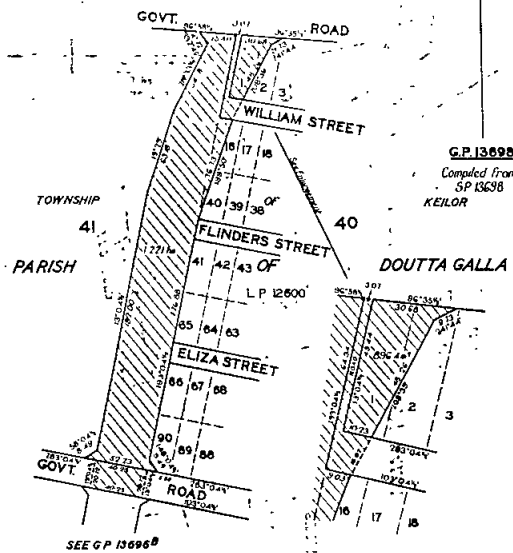

3rd February, 1977.

N. L. ALLANSON,  
Secretary.

BULLOCK CREEK IMPROVEMENT TRUST.

BY-LAW No. 7.

The Bullock Creek Improvement Trust, in pursuance and exercise of the powers conferred by the River Improvement Act 1958, doth make the By-Law following:—

1. The following rate, to be called the Bullock Creek District River Improvement Rate, is hereby made and shall be levied upon the occupiers or owners of all properties within the Bullock Creek Improvement District which are rateable to any Municipality, a rate of one cent in the dollar on the net annual Municipal value of all those properties within the First Division of the District.

Provided that the sum of Two Dollars shall be the minimum amount payable in respect of any property liable to be rated in the said division.

2. Such rates are made and shall be levied for the year beginning with the 1st day of January, 1977 and ending with the 31st day of December, 1977 and shall be payable on the 1st day of March, 1977 at the Office of the Bullock Creek Improvement Trust, Shire Office, Boort.

3. Such person or persons as the Bullock Creek Improvement Trust may from time to time appoint for that purpose shall be and is or are authorized to demand, receive, collect and recover the said rate.

The foregoing By-Law was made by the Bullock Creek Improvement Trust on the 26th January, 1977, and the common seal of the said Trust was hereunder affixed, on the 26th January, 1977, in the presence of—

R. A. RITCHIE, Chairman.  
D. A. SICKLES, Commissioner.  
L. WRIGHT, Secretary.

Approved, 8th February, 1977.—F. J. GRANTER, Minister of Water Supply.

CUDGEWA WATERWORKS TRUST.

RATING BY-LAW No. 114.

The Cudgewa Waterworks Trust, in pursuance of and in exercise of the powers conferred by the Water Act doth hereby make a By-Law for the supply of water by measure; for the year commencing the 1st day of January, 1977.

The maximum quantity of water to be supplied in any one year without further charge to any property rated by the Trust is hereby fixed at the quantity which at a charge of 11c per kilolitre would produce an amount equal to the amount of the rate levied on such property for the same year.

The charge for the water supplied by measure to any property rated by the Trust in excess of such maximum quantity computed as in the last preceding clause is hereby fixed at 11c per kilolitre.

The charge for water supplied by measure to any property not rated by the Trust is hereby fixed at 11c per kilolitre.

The charge for water supplied by measure shall be payable on demand at the office of the Trust.

Passed on the 16th day of December, 1976.

K. R. JARVIS, Chairman.  
D. CARKEEK, Commissioner.  
R. H. BARKER, Secretary.

Approved, 3rd February, 1977.—F. J. GRANTER, Minister of Water Supply.

WHITFIELD WATERWORKS TRUST.

FIRST ELECTION OF COMMISSIONERS.

His Excellency the Governor of the State of Victoria by and with the advice of the Executive Council thereof doth by Order made on the 15th day of February, 1977, approve the 30th March, 1977, as the day on which the Whitfield Waterworks Trust shall hold its first election of Commissioners, such election to take place at the Whitfield Hall subject to the provisions of the Water Act.

TOM FORRISTAL,  
Clerk of the Executive Council.

At the Executive Council Chamber,  
Melbourne, 15th February, 1977.

## Melbourne and Metropolitan

## BOARD OF WORKS.

## GENERAL NOTICE.

The Melbourne and Metropolitan Board of Works having made provision for carrying off the sewage of each and every property which or any part of which is situate in the Sewerage Areas hereinafter described doth hereby declare that on and after the 21st day of February, 1977, each and every property so situate shall be deemed to be a sewered property within the meaning of the *Melbourne and Metropolitan Board of Works Act 1958*.

The Sewerage Areas hereinbefore referred to are:—

*Sewerage Area No. 3171.*

*City of Springvale.*—Commencing at the junction of Boundary Road and Governor Road, thence easterly along Governor Road, southerly along the eastern boundaries of lots 4 Governor Road and 8 Canterbury Road, further southerly by a line to and along the eastern boundaries of lots 18 to 15 Haymer Court, generally south-westerly along the south-eastern boundary of lot 14 Haymer Court, south-westerly and westerly along the south-eastern and southern boundaries of a reserve, northerly along Boundary Road to the commencing point.

*Sewerage Area No. 3172.*

*City of Keilor.*—Commencing at the junction of Pindari Avenue and Lake Drive, thence northerly along Lake Drive, south-easterly along the north-eastern boundaries of lots 1 to 3 Pindari Avenue, easterly along the northern boundaries of lots 4 to 20 Pindari Avenue, south-easterly along the north-eastern boundaries of lots 20 to 25 Pindari Avenue, 27 to 38 Broula Court, a reserve, 248 to 251 Koroit Place and 267 to 269 Mara Court, southerly along the eastern boundaries of lots 269 and 270 Mara Court and lot A Apollo Road, westerly along Apollo Road, northerly along the western boundary of lot 219 Apollo Road, westerly along the southern boundary of lot 222 Lake Drive, northerly along Lake Drive to the commencing point.

*Sewerage Area No. 3173.*

*City of Moorabbin.*—Commencing at the junction of Bourke Road and Allwen Court, thence southerly along Allwen Court, south-easterly and south-westerly along the north-eastern and south-eastern boundaries of lot 5 Allwen Court, westerly along the southern boundaries of lots 5 and 4 Allwen Court, southerly along the eastern boundaries of portion of lot 7 and lot 8 Bushland Avenue, south-westerly along the south-eastern boundaries of lots 8 to 13 Bushland Avenue, westerly along the southern boundaries of lots 13 to 17 Bushland Avenue and 2 Bourke Road, northerly along the western boundary of the said lot 2, easterly along Bourke Road to the commencing point.

*Sewerage Area No. 3174.*

*City of Broadmeadows.*—Commencing at the junction of Boeing Road and Lockheed Street, thence southerly along Lockheed Street, westerly along the southern boundaries of lots 239 and 238 Boeing Road, northerly along the western boundary of the said lot 238, north-westerly along Boeing Road, further north-westerly, westerly and northerly along Mascoma Street, northerly along the western boundary of lot 1 Palagia Court, easterly along the northern boundaries of lots 1 to 7 Palagia Court, 397 to 404 and 1 to 9 Caravalle Crescent, 346 to 348 Vickers Avenue and 368 to 370 De Havilland Avenue, southerly along the eastern boundaries of lots 371 to 379 and 308 to 295 De Havilland Avenue and 217 and 218 Boeing Road, north-westerly along Boeing Road to the commencing point.

*Sewerage Area No. 3175.*

*City of Nunawading.*—Commencing at the junction of Beaumont Street and Boronia Road, thence south-easterly along Boronia Road, southerly along Philip Street, south-easterly and easterly along Trinian Street, southerly along Morack Road, easterly along Caringa Drive, southerly along Devlin Street, westerly along the southern boundary of lot 49 Devlin Street, southerly along the eastern boundaries of portion of lot 40 and lots 39 and 38 Batman Court, easterly, southerly and westerly along portion of the northern, the eastern and southern boundaries of the Vermont High School, northerly along Morack Road, westerly along Tucker Road, northerly along Philip Street, westerly along the southern boundaries of lots 13 Philip Street and 12 and 11 Lunar Crescent, northerly along the western boundaries of lots 10 to 5 Lunar Crescent, south-easterly along the north-eastern boundary of the said lot 5, easterly along Lunar Crescent, northerly along the western boundaries of lots 2 and 1 Philip Street, easterly along the northern boundary of the said lot 1, northerly along Philip Street, westerly and north-westerly along Karwitha Street, southerly along the eastern boundary of lot 20 Karwitha Street, north-westerly along the south-

westerly boundaries of lots 20 and 2 and 1 Karwitha Street, southerly along the eastern boundaries of lots 13 to 9 and 3 Nurlendi Road, westerly along the southern boundary of the said lot 3, northerly along Nurlendi Road, westerly along the southern boundary of lot 7 Nurlendi Road, northerly along the western boundaries of lots 7 and 6 Nurlendi Road and 3 Cantley Lane, westerly along Cantley Lane, northerly along Terrara Road to the boundary of Sewerage Area No. 1899, easterly, generally north-easterly and northerly along the said boundary to the commencing point.

*Sewerage Area No. 3176.*

*City of Sunshine.*—Commencing at the junction of Bailey Street and Furlong Road, thence westerly along Furlong Road, northerly along Levenia Street, easterly along Lima Street, southerly along Bailey Street to the commencing point.

*Sewerage Area No. 3177.*

*City of Croydon.*—Commencing at the junction of Bayswater Road and Bluemist Drive, thence westerly along Bluemist Drive, northerly along Mariana Avenue, westerly along the southern boundary of lot 13 Mariana Avenue, northerly along the western boundaries of lots 13 and portion of 12 Mariana Avenue, westerly along the southern boundary of lot 26 Pleasant Rise, southerly and south-westerly along Pleasant Rise, northerly along Long View Road, easterly along The Mount, northerly along the western boundaries of lots 5, 6 and 2 The Mount and 4 Eastfield Road, westerly along Eastfield Road, north-easterly along the north-western boundary of lot 20 Eastfield Road, north-westerly along the south-western boundary of lot 5 The Pass, northerly along The Pass, north-easterly along the north-western boundaries of lots 100 and 99 The Pass, further north-easterly along Hillside Drive, south-easterly and south-westerly along the north-eastern and portion of the south-eastern boundaries of lot 86 Hillside Drive, south-easterly along the north-eastern boundary of lot 74 Orchard Drive, north-easterly along Orchard Drive, south-easterly along the north-eastern boundary of Cheong Park, southerly along Bayswater Road to the commencing point.

*Sewerage Area No. 3178.*

*City of Moorabbin.*—Commencing at the junction of Tiffany Avenue and Nancy Street, thence easterly along Nancy Street, southerly along Snowdon Drive, easterly along the northern boundary of lot 34 Snowdon Drive, southerly along the eastern boundaries of lots 34 to 42, 48 and 43 to 47 Snowdon Drive, westerly along the southern boundary of the said lot 47, further westerly along Snowdon Drive, northerly along Tiffany Avenue to the commencing point.

*Sewerage Area No. 3179.*

*City of Nunawading.*—Commencing at the junction of Burwood Highway and Springvale Road, thence northerly along Springvale Road, easterly and southerly along the northern and portion of the eastern boundaries of the Burvale Hotel-Motel, easterly along the northern boundary of lot 87 Kindra Court, further easterly along Kindra Court, southerly along portion of the eastern boundary of lot 91 Kindra Court, easterly along the northern boundary of lot 73 Consort Avenue, further easterly by a line to and along the northern boundaries of lots 51 Consort Avenue and 46 Dalroy Crescent, southerly along Dalroy Crescent, easterly along Burwood Highway, generally southerly along the eastern boundary of Billabong Park, north-easterly along Weeden Drive, southerly along the eastern boundary of lot 21 Weeden Drive, easterly and southerly along portions of the northern and eastern boundaries of lot 8 Highbury Road, easterly along the northern boundary of lot 10 Stradella Avenue, southerly along Stradella Avenue, westerly along Highbury Road, northerly along portion of the western boundary of lot 8 Highbury Road, westerly along the southern boundary of lot 33 Sherwood Rise, further westerly along Eagle Court and the southern boundary of lot 20 Eagle Court, northerly along portion of the western boundary of the said lot 20, westerly along the southern boundary of lot 66 Coral Court, northerly along Coral Court, westerly along Weeden Drive, generally northerly along portion of the western boundary of Billabong Park, further northerly along Tullimbar Circuit, easterly along the northern boundary of lot 33 Tullimbar Circuit, north-westerly and generally northerly along portion of the western boundary of Billabong Park, further northerly along the western boundary of lot 1 Burwood Highway, westerly along Burwood Highway to the commencing point.

*Sewerage Area No. 3180.*

*City of Nunawading.*—Commencing at the western extremity of Wattle Valley Road, thence northerly along the western boundary of lot 1 Wattle Valley Road, easterly, along the northern boundaries of lots 1 to 10 Wattle

Valley Road, southerly along the eastern boundary of the said lot 10, south-westerly by a line to the eastern angle of lot 11 Wattle Valley Road, westerly along the southern boundaries of lots 11 to 16 Wattle Valley Road, northerly along the western boundary of the said lot 16 to the commencing point.

*Sewerage Area No. 3181.*

*City of Waverley.*—Commencing at the junction of Cairn Grove and Capital Avenue, thence north-westerly along Capital Avenue, north-easterly along the north-western boundaries of lots 154 Capital Avenue and 151 Cairn Grove, easterly and southerly along the northern and eastern boundaries of the said lot 151, south-westerly along Cairn Grove, south-easterly along the north-eastern boundaries of lots 145 to 143 Capital Avenue, south-westerly along the south-eastern boundary of the said lot 143, north-westerly along Capital Avenue to the commencing point.

*Sewerage Area No. 3182.*

*City of Knox.*—Commencing at the junction of Forest Road and Burwood Highway, thence south-westerly and westerly along Burwood Highway, northerly along the western boundary of that land described on Consolidated Plan No. 100986, easterly along Garnet Street, north-easterly and northerly along The Avenue, north-westerly along Vella Court and the south-western boundary of lot 1 Vella Court, north-easterly along the north-western boundaries of lot 1 and portion of lot 2 Vella Court, north-westerly along the south-western boundary of lot 12 Bruce Crescent, north-easterly and north-westerly along Bruce Crescent, south-easterly along Alma Avenue, easterly along the northern boundaries of lots 13 to 11 The Avenue, south-easterly along Wyuna Street, north-easterly along the north-western boundaries of lots 1 and 2 The Avenue, easterly along Station Street, north-easterly along Alpine Street to the Belgrave railway line, south-easterly along the said railway line, southerly along the eastern boundary of lot 122A Burwood Highway, westerly and south-westerly along Burwood Highway to the commencing point.

*Sewerage Area No. 3183.*

*Shire of Whittlesea.*—Commencing at the junction of Main Street and Christian Road, thence northerly along Christian Road, easterly along the northern boundary of St. Clares Primary School, southerly along Harbard Street, westerly along portion of the southern boundary of the said school, southerly along the eastern boundary of lot 268 Main Street, westerly along Main Street to the commencing point.

*Sewerage Area No. 3184.*

*City of Sunshine.*—Commencing at the junction of Browne Avenue and Furlong Road, thence easterly along Furlong Road, generally southerly along the eastern boundary of lot 213 Furlong Road, further southerly, westerly and northerly along the eastern, southern and portion of the western boundaries of a reserve, westerly along Kerry Court, southerly and westerly along the eastern and southern boundaries of lot 176 Browne Avenue, northerly along Browne Avenue to the commencing point.

*Sewerage Area No. 3185.*

*City of Knox.*—Commencing at the junction of Borg Street and Ferntree Gully Road, thence westerly along Ferntree Gully Road, northerly by a line to and along the western boundaries of lots 31 and 32 Denham Court and a line in continuation to the northern boundary of a reserve, easterly along portion of the northern boundary of the said reserve, northerly along the western boundary of lot 12 Carol Street, easterly along Carol Street, northerly along Impara Court and the western boundary of lot 4 Impara Court, north-westerly and north-easterly along portion of the south-western and the north-western boundaries of lot 77 Borg Street, south-easterly along Borg Street, south-westerly along Carol Street, south-easterly along the north-eastern boundary of lot 67 Carol Street, north-easterly along portion of the north-western boundary of lot 11 Borg Street, south-easterly and southerly along Borg Street to the commencing point.

*Sewerage Area No. 3186.*

*City of Keilor.*—Commencing at the junction of Herbert Street and Clarendon Street, thence easterly along Clarendon Street, southerly along Sydney Street, westerly along Canning Street, northerly along Herbert Street to the commencing point.

*Sewerage Area No. 3187.*

*City of Croydon.*—Commencing at the junction of Bayswater Road and Morris Road, thence easterly along Morris Road, south-westerly along the south-eastern boundaries of lots 9 Morris Road and 2 Bayswater Road, westerly along the southern boundaries of portion of lot 2 and lot 1 Bayswater Road, northerly along Bayswater Road to the commencing point.

*Sewerage Area No. 3188.*

*City of Croydon.*—Commencing at the junction of Vinter Avenue and Lusher Road, thence south-westerly along Lusher Road, easterly and southerly along the northern and eastern boundaries of lot 5 Lusher Road, south-easterly, south-westerly and westerly along the north-eastern, south-eastern and southern boundaries of lot 9 Lusher Road, southerly along Lusher Road, westerly and northerly along the southern and western boundaries of lot 2 Ronald Road, westerly along Ronald Road, southerly along Park Lane, westerly along the southern boundary of lot 18 Park Lane, further westerly and northerly along the southern and western boundaries of lot 4 Ronald Road, westerly along Ronald Road, southerly along Bayswater Road, westerly along the southern boundary of lot 32 Bayswater Road, north-westerly along the south-western boundary of lot 2 Orchard Drive, south-westerly along Orchard Drive, north-westerly and north-easterly along the south-western and portion of the north-western boundaries of lot 73 Orchard Drive, north-westerly along the south-western boundary of lot 87 Hillside Drive, north-easterly along Hillside Drive, easterly along Yarraduct Place South, northerly along Bayswater Road, westerly along Vinter Avenue to the commencing point.

*Sewerage Area No. 3189.*

*City of Broadmeadows.*—Commencing at the junction of Kenny Street and Shadforth Street, thence southerly along Shadforth Street, easterly along Raleigh Street, southerly along Campbell Street, north-westerly along Johnstone Street to Shadforth Street, south-westerly by a line to the Moonee Ponds Creek, generally south-westerly and north-westerly along the said creek, northerly by a line to the western extremity of Kenny Street, easterly along Kenny Street to the commencing point.

*Sewerage Area No. 3190.*

*City of Waverley.*—Commencing at the junction of Springvale Road and Clifford Street, thence easterly along Clifford Street, further easterly along Garrison Drive, southerly along Gallaghers Road, westerly along the southern boundaries of lots 1 Gallaghers Road, 12 to 24 Driftwood Drive and 16 Wolseley Avenue, further westerly by a line to and along the southern boundaries of lots 12 Wolseley Avenue and 8 Rolls Avenue, southerly along Rolls Avenue, generally north-westerly, northerly and westerly along Hinkler Road, northerly along Springvale Road to the commencing point.

*Sewerage Area No. 3191.*

*City of Preston.*—Commencing at the junction of Albert Street and Gower Street, thence easterly along Gower Street, southerly along the eastern boundary of lot 67 Gower Street, easterly and southerly along the northern and eastern boundaries of lot 101 Harrow Street, south-westerly by a line to the north-eastern angle of lot 107 Harrow Street, southerly along the eastern boundaries of the said lot 107 and lot 142 Eton Street, westerly along Eton Street, northerly along the western boundary of lot 144 Eton Street, westerly along the southern boundary of lot 56 Albert Street, northerly along Albert Street to the commencing point.

*Sewerage Area No. 3192.*

*City of Moorabbin.*—Commencing at the junction of Greendale Road and Bignell Road, thence southerly along Bignell Road, westerly along Brosnan Road, northerly along Blamey Street, westerly along the southern boundaries of lots 54 Blamey Street and 61 Norville Street, northerly along Norville Street, westerly along the southern boundaries of lots 74 Norville Street and 93 Brady Road, northerly along Brady Road, easterly along the northern boundary of lot 55 Brady Road, northerly along portion of the western boundary of lot 54 Greendale Road, easterly along Greendale Road to the commencing point.

*Sewerage Area No. 3193.*

*City of Moorabbin.*—Commencing at the junction of South Road and Warrigal Road, thence southerly along Warrigal Road, westerly along the southern boundaries of lots 17 to 13 Wren Road, further westerly by a line to and along the southern boundaries of lots 7 to 1 Wren Road, north-westerly along the south-western boundary of the said lot 1, further north-westerly along Kings Way, westerly along South Road to a point about 940 feet east of the eastern boundary of Bignell Road, northerly along the western boundary of a M.M.B.W. property, westerly along portion of the southern boundary of the Moorabbin Heights State School, northerly along Bignell Road, easterly along portion of the northern boundary of the said school, north-westerly along the south-western boundary of lot 25 Gladesville Drive, westerly along Gladesville Drive, northerly along Bignell Road, easterly and south-easterly along the northern and north-eastern

portions of Pasadena Crescent, easterly along the northern boundary of lot 16 Pasadena Crescent and a line in continuation to McGuinness Road, northerly along McGuinness Road, easterly, southerly and easterly along the northern and portion of the eastern boundaries of the Yarra Yarra Golf Course, southerly along Warrigal Road to the commencing point.

*Sewerage Area No. 3194.*

*City of Waverley.*—Commencing at the junction of Northam Street and Roycroft Close, thence northerly along Roycroft Close, north-westerly and easterly along the south-western and portion of the northern boundaries of lot 74 Roycroft Close, northerly along the western boundary of lot 112 Chapman Boulevard, easterly along Chapman Boulevard, northerly and south-easterly along the western and north-eastern boundaries of lot 29 Chapman Boulevard, further south-easterly by a line to and along the north-eastern boundary of lot 24 Chapman Boulevard, westerly along the southern boundary of the said lot 24, southerly along Chapman Boulevard, westerly along Northam Street to the commencing point.

*Sewerage Area No. 3195.*

*City of Berwick.*—Commencing at the junction of Trentwood Road and Prospect Hill Road, thence easterly along Prospect Hill Road and the northern boundaries of lots 563 and 562 Coral Gum Court, south-easterly along the north-eastern boundaries of lots 561 Coral Gum Court, 558 and 473 to 493 Summerlea Road, south-westerly along the south-eastern boundary of the said lot 493 to the boundary of Sewerage Area No. 3037, generally north-westerly and southerly along the said area boundary to Wallaroo Avenue, westerly along Wallaroo Avenue, northerly along the western boundary of lot 237 Wallaroo Avenue, westerly along portion of the southern boundary of lot 377 Mustang Avenue, northerly along Mustang Avenue, westerly along the southern boundaries of lots 368 Mustang Avenue and 282 Cloverset Avenue, northerly along Cloverset Avenue, westerly along the southern boundary of lot 544 Cloverset Avenue, northerly along the western boundaries of the said lot 544 and lots 543 to 541 White Ash Court and 520 Prospect Hill Road, easterly along Prospect Hill Road to the commencing point.

*Sewerage Area No. 3196.*

*Shire of Whittlesea.*—Commencing at the junction of High Street and Childs Road, thence easterly along Childs Road, southerly and westerly along the eastern and southern boundaries of lot 142 Childs Road, southerly along Gibson Street, easterly and southerly along the northern and eastern boundaries of lot 138 Monash Street, westerly along Monash Street, southerly along the eastern boundary of lot 133 Monash Street, westerly along the southern boundaries of lots 133 and 132 Monash Street, southerly along Ballarat Street, easterly and southerly along the northern and eastern boundaries of lot 26 Partridge Street, westerly along Partridge Street and a line in continuation to High Street, northerly along High Street to the commencing point.

*Sewerage Area No. 3197.*

*Shire of Whittlesea.*—Commencing at the junction of Coral Court and Partridge Street, thence south-westerly and westerly along Partridge Street, northerly and easterly along the western and portion of the northern boundaries of lot 1 Partridge Street, northerly along the western boundary of lot 3 Monash Street, further northerly along the western boundaries of lots 95 Monash Street and 153 Childs Road, easterly along Childs Road, southerly along the eastern boundaries of lots 138 Childs Road and 110 Monash Street, easterly along Monash Street, southerly along the eastern boundary of lot 160 Monash Street, easterly and south-easterly along the northern and north-eastern boundaries of lot 176 Coral Court, south-easterly along Coral Court to the commencing point.

*Sewerage Area No. 3198.*

*Shire of Whittlesea.*—Commencing at the junction of Betula Avenue and Plenty Road, thence southerly along Plenty Road, westerly by a line to and along the southern boundary of lot 94 Japonica Street, southerly along Japonica Street, westerly and south-westerly along Tarata Court, north-westerly along the south-western boundary of lot 77 Tarata Court, south-westerly along the south-eastern boundaries of portion of lot 64 and lots 63 to 54 and 157 to 153 Betula Avenue, southerly along the eastern boundary of lot 147 Japonica Street, westerly along Japonica Street, southerly along the eastern boundary of lot 172 Japonica Street, westerly along the southern boundaries of lots 172 to 170 Japonica Street, 202 to 211 and 428 to 430 Betula Avenue, further westerly by a line

to and along the southern boundaries of lots 431 to 438 Betula Avenue and 442 Millson Close, northerly along the western boundary of the said lot 442, north-easterly along Millson Close, south-easterly along Betula Avenue, north-easterly along the north-western boundary of lot 418 Betula Avenue, north-westerly and northerly along portion of the south-western and the western boundaries of lot 340 Bryson Court, easterly along Bryson Court, southerly along the eastern boundary of lot 341 Bryson Court, north-easterly along portion of the north-western boundary of lot 344 Carbeen Drive, easterly along Carbeen Drive, northerly along the western boundary of a reserve, further northerly by a line to and along the western boundary of lot 283 Hibiscus Avenue, easterly along the northern boundaries of lots 283 Hibiscus Avenue, 279 to 270 and 29 to 22 Ebony Drive, 20 and 19 Lucilla Place, 11 to 9 Primula Close, 7 to 1 Betula Avenue and a line in continuation to Plenty Road, southerly along Plenty Road to the commencing point.

*Sewerage Area No. 3199.*

*City of Nunawading.*—Commencing at the junction of Matheson Road and Calypso Court, thence easterly along Calypso Court, southerly along the eastern boundary of lot 23 Calypso Court, westerly along the southern boundaries of lots 23 to 37 Calypso Court, north-westerly along the south-western boundaries of lots 37 and 38 Calypso Court, northerly along the western boundaries of lots 38 and 39 Calypso Court, easterly along the northern boundaries of lots 39 to 42 Calypso Court to the commencing point.

*Sewerage Area No. 3200.*

*City of Waverley.*—Commencing at the junction of High Street Road and Mimosa Street, thence southerly along Mimosa Street, westerly along Brynor Crescent, southerly along Gallaghers Road, westerly along Garrison Drive, northerly along Danien Street, easterly along Mandowie Road, northerly along Arianne Road, easterly along Kincumber Drive, northerly along the western boundaries of lots 48 Kincumber Drive and 32 High Street Road, easterly along High Street Road, northerly along Westlands Road, easterly along the northern boundary of lot 31 Westlands Road, northerly and easterly along portion of the western and the northern boundaries of lot 185 Nith Court, northerly along Nith Court, easterly and northerly along Lomond Drive, north-easterly along Tweed Court and the north-western boundary of lot 163 Tweed Court, easterly along the northern boundary of the said lot 163 to a M.M.B.W. pipe track, south-westerly along the said pipe track, easterly along High Street Road to the commencing point.

*Sewerage Area No. 3201.*

*City of Broadmeadows.*—Commencing at the junction of Devereaux Street and Chris Court, thence southerly along Chris Court, the eastern boundary of lot 8 Chris Court and a line in continuation to the Moonee Ponds Creek, generally south-westerly and northerly along the said creek to a point on the line of continuation of Devereaux Street, easterly by a line to and along Devereaux Street to the commencing point.

*Sewerage Area No. 3202.*

*City of Preston.*—Commencing at the junction of Marshall Drive and Burbank Drive, thence north-easterly along Burbank Drive, north-westerly along the south-western boundary of lot 192 Burbank Drive, north-easterly along the north-western boundaries of lots 192 to 194 Burbank Drive, north-westerly along a right-of-way, north-easterly along the north-western boundary of lot 220 Roff Street, north-westerly along Roff Street, easterly along San Leandro Drive, northerly along Bridgeton Street, easterly along Tunaley Parade, northerly along the western boundary of lot 27 Tunaley Parade, easterly along the northern boundaries of lots 27 to 52 Tunaley Parade, south-westerly along the Maroondah Aqueduct, north-westerly along Marshall Drive to the commencing point.

*Sewerage Area No. 3203.*

*City of Waverley.*—Commencing at the junction of Amblecote Crescent and Gladeswood Drive, thence easterly along Gladeswood Drive, southerly along the eastern boundary of lot 202 Gladeswood Drive, easterly along portion of the northern boundary of lot 189 Acland Close, southerly along the eastern boundaries of lots 189 to 191 Acland Close, westerly along the southern boundary of the said lot 191, north-westerly by a line to the south-eastern angle of lot 197 Acland Close, westerly along the southern boundaries of the said lot 197 and lot 201 Amblecote Crescent, northerly along Amblecote Crescent to the commencing point.

*Sewerage Area No. 3204.*

*City of Doncaster and Templestowe.*—Commencing at the junction of Walter Street and Vera Street, thence southerly along Vera Street, westerly along the southern boundaries of lots 14 to 21 Walter Street, northerly along the western boundary of the said lot 21, further northerly by a line to and along the western boundary of lot 1 Walter Street, easterly along the northern boundaries of lots 1 to 7 and portion of 8 Walter Street to the boundary of Sewerage Area No. 2369, southerly and easterly along the said boundary to the commencing point.

*Sewerage Area No. 3205.*

*City of Croydon.*—Commencing at the junction of Dorset Road and Hull Road, thence easterly along Hull Road, southerly, easterly, southerly and westerly along the eastern and southern boundaries of lot 1 Hull Road, southerly along the eastern boundaries of lots 11 to 13 Donald Street, easterly by a line to and along the northern boundary of lot 1 Mount Dandenong Road, northerly and easterly along portion of the western and the northern boundaries of lot 13 Henty Court, southerly along Henty Court and the eastern boundaries of lots 9 Henty Court and 18 Mount Dandenong Road, westerly along Mount Dandenong Road, southerly along Dorset Road, westerly along a M.M.B.W. pipe track, northerly by a line to and along the western boundary of a right-of-way at the rear of lots 22 to 18 Alfrick Road, westerly along the southern boundary of lot 6 Turner Street, further westerly by a line to and along the southern boundaries of lots 13 Turner Street and 24 Norton Road, northerly along Norton Road, easterly along Mount Dandenong Road, northerly along Springfield Avenue, westerly along Hewish Road, northerly along Windsor Road, easterly along Lacey Street, northerly along Sturt Street, easterly along Jackson Street, southerly along Dorset Road to the commencing point.

*Sewerage Area No. 3206.*

*Shire of Whittlesea.*—Commencing at the junction of Chaffey Street and Strong Avenue, thence north-easterly along the north-western boundary of lot 54 Strong Avenue, easterly and southerly along the northern and eastern boundaries of lot 55 Strong Avenue, further southerly by a line to and along the eastern boundaries of lots 56 to 74 Chaffey Street, westerly along the southern boundary of the said lot 74, northerly along Chaffey Street, westerly along the southern boundaries of lots 39 Chaffey Street and 31 Strong Avenue, northerly along Strong Avenue, westerly along the southern boundary of lot 6 Edgars Road and a line in continuation to Edgars Road, northerly along Edgars Road, easterly by a line to and along the northern boundary of lot 18 Edgars Road, further easterly and north-easterly along Strong Avenue to the commencing point.

*Sewerage Area No. 3207.*

*City of Knox.*—Commencing at the junction of Hillary Street and Borg Street, thence south-easterly along Borg Street, south-westerly along the south-eastern boundary of lot 78 Borg Street, south-easterly and southerly along portion of the north-eastern and eastern boundaries of lot 3 Impara Court, southerly along Impara Court, westerly along Carol Street, southerly along the eastern boundary of lot 13 Carol Street, further southerly by a line to and along the eastern boundaries of lots 2 and 1 Borg Street and a line in continuation to Ferntree Gully Road, westerly along Ferntree Gully Road, north-westerly along Cathies Lane, north-easterly along the north-western boundary of lot 48 Borg Street, further north-easterly by a line to and along the north-western boundary of lot 70 Borg Street, north-westerly along the south-western boundary of lot 74 Holbein Court, north-easterly along Holbein Court and the north-western boundary of lot 81 Holbein Court, further north-easterly and easterly along the north-western and northern boundaries of lot 34 Drysdale Court, northerly along Drysdale Court, westerly and north-westerly along the southern and the south-western boundaries of lot 33 Drysdale Court, north-easterly along the north-western boundaries of lots 33, 32 and 31 Drysdale Court, further north-easterly along Hillary Street to the commencing point.

*Sewerage Area No. 3208.*

*City of Broadmeadows.*—Commencing at the junction of the southern portion of Roebourne Crescent and Cheviot Road, thence southerly along Cheviot Road, westerly along the southern boundary of lot 68 Cheviot Road, north-westerly along the south-western boundary of lot 60 Kalgoorlie Court, northerly along Kalgoorlie Court and Roebourne Crescent, westerly along the southern boundary of lot 48 Roebourne Crescent, south-westerly and northerly along portion of the south-eastern and the

western boundaries of a reserve, easterly along the northern boundaries of the said reserve and lots 103 to 90 Roebourne Crescent, south-westerly along the south-eastern boundary of the said lot 90, southerly and westerly along Roebourne Crescent to the commencing point.

*Sewerage Area No. 3209.*

*Shire of Whittlesea.*—Commencing at the junction of Plenty Road and Mayfield Drive, thence westerly along Mayfield Drive to the boundary of Sewerage Area No. 3087, generally north-westerly along the said boundary to the junction of Archer Place and Statesman Crescent, north-easterly, easterly and south-easterly along Statesman Crescent, north-easterly along Wakeful Place, the north-western boundary of lot 386 Wakeful Place and a line in continuation to Plenty Road, southerly along Plenty Road to the commencing point.

*Sewerage Area No. 3210.*

*City of Waverley.*—Commencing at the junction of Heysham Drive and Jells Road, thence southerly along Jells Road, westerly along the southern boundary of lot 48 Darlington Avenue, south-westerly along the south-eastern boundaries of lots 47 to 45 Darlington Avenue, westerly along the southern boundaries of lots 45 to 32 Darlington Avenue, northerly along the western boundary of the said lot 32, further northerly by a line to and along the western boundaries of lots 31 to 25 Milford Avenue and 16 Sunnybrook Drive to the boundary of Sewerage Area No. 2540, northerly, easterly, southerly and easterly along the said boundary to Jells Road, southerly along Jells Road to the commencing point.

By order of the Board,

R. H. ENGELSMAN,  
Secretary.

625 Little Collins Street, Melbourne, 3001, 15th February, 1977.

## LOCAL GOVERNMENT DEPARTMENT.

## ORDER CONFIRMED.—SHIRE OF KOWREE.

The Minister of the Crown administering the *Local Government Act 1958*, on the ninth day of February, 1977, confirmed the Order hereinafter referred to in pursuance of section 514 of the said Act, namely:

An Order of the Council of the Shire of Kowree made on the 7th January, 1977, directing the compulsory taking of the land described as allotment 9 of section 2 in the Township of Goroke for the purposes of development of a Senior Citizens Clubhouse.

A. J. HUNT,

Minister for Local Government.

Local Government Department,  
Melbourne (76/5417).*Town and Country Planning Act 1961.*

## CITY OF FRANKSTON PLANNING SCHEME.

## AMENDMENT No. 12.

*Notice of Amendment.*

In pursuance of the powers conferred by sub-section 6 of section 32 of the *Town and Country Planning Act 1961*, the Governor in Council, on the 15th February, 1977, amended the City of Frankston Planning Scheme, to require a permit for the establishment of "office" and "shop" in the Local Business zone.

A copy of the amendment may be inspected during office hours at the office of the Town and Country Planning Board, 235 Queen Street, Melbourne, at the office of the Council of the City of Frankston at Frankston, and when available at the Office of Titles, Melbourne, and at the Central Plan Office of the Department of Crown Lands and Survey, Melbourne.

W. H. CRAIG, Secretary,  
Town and Country Planning Board.*Town and Country Planning Act 1961.*

## SHIRE OF MCVIVOR PLANNING SCHEME.

## INTERIM DEVELOPMENT ORDER.

## AMENDMENT No. 11.

*Notice of Amendment.*

In pursuance of the powers conferred by section 26 of the *Town and Country Planning Act 1961*, the Governor in Council on the 8th day of February, 1977, amended the Shire of McIvor Planning Scheme Interim Development



Order to enable part of Crown allotment 11, Parish of Knowsley, to be subdivided into four allotments of approximately 12 hectares each.

A copy of the amendment may be inspected during office hours at the office of the Town and Country Planning Board, 235 Queen Street, Melbourne, and at the office of the Council of the Shire of McIvor at Heathcote.

W. H. CRAIG, Secretary,  
Town and Country Planning Board.

*Town and Country Planning Act 1961.*  
SHIRE OF OXLEY PLANNING SCHEME.

INTERIM DEVELOPMENT ORDER.

*Notice of Approval.*

In pursuance of the powers conferred by the *Town and Country Planning Act 1961*, the Governor in Council on the 8th day of February, 1977, approved an Interim Development Order made by the Oxley Shire Council for the municipal district of the Shire of Oxley including the Lake Buffalo Planning Scheme but excluding that part of the Shire included in the Wangaratta Sub-Regional Planning Scheme. The Interim Development Order provides that the use, subdivision or development of any land within the area described or the erection, construction or carrying out of any buildings, roads or other works thereon is prohibited except in accordance with the provisions of the Order.

A copy of the Interim Development Order and a map showing the area affected may be inspected, free of charge, at the office of the Council of the Shire of Oxley at Oxley and at the office of the Town and Country Planning Board, 235 Queen Street, Melbourne.

W. H. CRAIG, Secretary,  
Town and Country Planning Board.

*Town and Country Planning Act 1961.*  
SHIRE OF UPPER YARRA PLANNING SCHEME.

INTERIM DEVELOPMENT ORDER.

AMENDMENT NO. 22.

*Notice of Amendment.*

In pursuance of the powers conferred by Section 26 of the *Town and Country Planning Act 1961*, the Governor in Council on the 8th day of February, 1977 amended the Shire of Upper Yarra Planning Scheme Interim Development Order to provide for the excision of two allotments of 6 hectares each from a total area of 28 ha. being lots 1 and 2 lodged plan 93223, Parish of Woori Yallock on the Yarra Junction—Noojee Road to provide allotments for two existing houses.

A copy of the amendment may be inspected during office hours at the office of the Town and Country Planning Board, 235 Queen Street, Melbourne and at the office of the Council of the Shire of Upper Yarra at Yarra Junction.

W. H. CRAIG, Secretary,  
Town and Country Planning Board.

*Town and Country Planning Act 1961.*  
BALLAARAT AND DISTRICT PLANNING SCHEME 1966.

AMENDMENT NO. 25, 1976.

(CITY OF BALLAARAT.)

*Notice of Approval.*

In pursuance of the powers conferred by the *Town and Country Planning Act 1961*, the Governor in Council on the 8th day of February, 1977, approved a planning scheme entitled the Ballaarat and District Planning Scheme 1966, Amendment No. 25, 1976 (City of Ballaarat) in respect of part of the municipal district of the City of Ballaarat and such planning scheme comes into operation on the date this Notice of Approval is published in the *Government Gazette*.

A copy of the planning scheme as approved may be inspected, free of charge, during office hours at the office of the Town and Country Planning Board, 235 Queen Street, Melbourne, at the office of the Council of the City of Ballaarat at Ballarat and when available, at the Office of Titles, Melbourne, and at the Central Plan Office of the Department of Crown Lands and Survey, Melbourne.

W. H. CRAIG, Secretary,  
Town and Country Planning Board.

*Town and Country Planning Act 1961.*  
EILDON RESERVOIR PLANNING SCHEME 1959.

AMENDMENT NO. 19, 1976.

(SHIRE OF MANSFIELD.)

*Notice of Approval.*

In pursuance of the powers conferred by the *Town and Country Planning Act 1961*, the Governor in Council on the 8th day of February, 1977, approved a planning scheme

entitled the Eildon Reservoir Planning Scheme 1959, Amendment No. 19, 1976 (Shire of Mansfield), in respect of part of the municipal district of the Shire of Mansfield and such planning scheme comes into operation on the date this Notice of Approval is published in the *Government Gazette*.

A copy of the planning scheme as approved may be inspected, free of charge, during office hours at the office of the Town and Country Planning Board, 235 Queen Street, Melbourne; at the office of the Council of the Shire of Mansfield at Mansfield, and when available, at the Office of Titles, Melbourne, and at the Central Plan Office of the Department of Crown Lands and Survey, Melbourne.

W. H. CRAIG, Secretary,  
Town and Country Planning Board.

*Town and Country Planning Act 1961.*  
LAKE BUFFALO PLANNING SCHEME.

INTERIM DEVELOPMENT ORDER.

REVOCATION NO. 1.

*Notice of Revocation.*

In pursuance of the powers conferred by Section 26 of the *Town and Country Planning Act 1961*, the Governor in Council on the 8th day of February, 1977, revoked the Lake Buffalo Planning Scheme Interim Development Order for that part within the municipal district of the Shire of Oxley.

A copy of the revocation may be inspected during office hours at the office of the Town and Country Planning Board, 235 Queen Street, Melbourne, and at the office of the Council of the Shire of Oxley at Wangaratta.

W. H. CRAIG, Secretary,  
Town and Country Planning Board.

*Town and Country Planning Act 1961.*  
MELBOURNE METROPOLITAN PLANNING SCHEME.

AMENDMENT NO. 57, PART 2A.

*Notice of Approval.*

In pursuance of the powers conferred by the *Town and Country Planning Act 1961*, the Governor in Council on the 15th February, 1977, approved a planning scheme entitled the Melbourne Metropolitan Planning Scheme, Amendment No. 57, Part 2A, in respect of part of the municipal district of the City of Doncaster and Templestowe and such planning scheme comes into operation on the date this Notice of Approval is published in the *Government Gazette*.

A copy of the planning scheme as approved may be inspected, free of charge, during office hours at the office of the Town and Country Planning Board, 235 Queen Street, Melbourne; at the office of the Melbourne and Metropolitan Board of Works at 625 Little Collins Street, Melbourne, and when available, at the Office of Titles, Melbourne, and at the Central Plan Office of the Department of Crown Lands and Survey, Melbourne.

W. H. CRAIG, Secretary,  
Town and Country Planning Board.

*Town and Country Planning Act 1961.*  
PORTLAND PLANNING SCHEME 1957.

AMENDMENT NO. 18, 1976—PART 2.

*Notice of Amendment.*

In pursuance of the powers conferred by sub-section 6 of section 32 of the *Town and Country Planning Act 1961*, the Governor in Council, on the 15th February, 1977, amended the Portland Planning Scheme 1957 to rezone part of Crown allotment 86, section 13, Parish of Portland located 6.5 km. south of Portland near Cape Sir William Grant from Agricultural to Industrial "B".

A copy of the amendment may be inspected during office hours at the office of the Town and Country Planning Board, 235 Queen Street, Melbourne, at the office of the Council of the Town of Portland at Portland, and when available at the Office of Titles, Melbourne and at the Central Plan Office of the Department of Crown Lands and Survey, Melbourne.

W. H. CRAIG, Secretary,  
Town and Country Planning Board.

*Town and Country Planning Act 1961.*  
SEYMOUR PLANNING SCHEME.

AMENDMENT NO. 19.

*Notice of Approval.*

In pursuance of the powers conferred by the *Town and Country Planning Act 1961*, the Governor in Council on the 8th day of February, 1977, approved a planning scheme

entitled the Seymour Planning Scheme, Amendment No. 19, in respect of part of the municipal district of the Shire of Seymour and such planning scheme comes into operation on the date this Notice of Approval is published in the *Government Gazette*.

A copy of the planning scheme as approved may be inspected, free of charge, during office hours at the office of the Town and Country Planning Board, 235 Queen Street, Melbourne; at the office of the Council of the Shire of Seymour at Seymour, and when available, at the Office of Titles, Melbourne, and at the Central Plan Office of the Department of Crown Lands and Survey, Melbourne.

W. H. CRAIG, Secretary,  
Town and Country Planning Board.

*Pounds Act 1958.*

SHIRE OF WERRIBEE.

Table of Rates to be charged for the Trespass of Cattle, and their sustenance while impounded fixed by the Council of the Shire of Werribee.

A. For Trespass.

Description of Cattle Trespassing.	Upon Tillage Land Enclosed by a Substantial Fence.	Upon Land other than Tillage Land Enclosed by a Substantial Fence.
	\$	\$
For every sheep .. .. .	0.50	0.03
For every goat .. .. .	5.00	1.00
For every pig .. .. .	5.00	1.00
For every head of other cattle ..	10.00	1.00
		\$
In addition for the trespass of any entire horse ..		20.00
In addition for the trespass of any bull ..		20.00
In addition for the trespass of any ram ..		20.00

B. For Sustenance.

Description of Cattle.	Amounts to be Charged Daily for Sustenance While Impounded.
	\$
For every sheep .. .. .	0.30
For every goat .. .. .	1.00
For every pig .. .. .	1.00
For every head of other cattle ..	2.00

NOTE: Section 10A of the *Pounds Act 1958* provides—  
Where a person impounding cattle conveys them to the pound by motor transport there shall be payable as a transport rate the expenses reasonably incurred by him in so conveying them to the pound.

By Order of the Council.

J. T. KERR,  
Shire Secretary.

Approved by the Governor in Council, 8th February, 1977.  
—TOM FORRISTAL, Clerk of the Executive Council.

PUBLIC TRUSTEE ACT 1958 (No. 6350), SECTION 17.

I hereby give notice that on the 25th January, 1977, the Public Trustee filed an election to administer the following deceased person's estate in accordance with section 17 of the *Public Trustee Act 1958*.

HAYES, JOHN TIMOTHY, late of Queen Elizabeth Geriatric Centre, 102 Ascot Street South, Ballarat, died 7th September, 1976.

I hereby give notice that on the 2nd February, 1977, the Public Trustee filed elections to administer the following deceased persons' estates in accordance with section 17 of the *Public Trustee Act 1958*.

HENRY, PETER JOHN, formerly of Giffords Road, Warburton, but late of 526 Seesburg Street, Cape Woolamai, Phillip Island, retired Board of Works inspector, died 7th October, 1976.

HILLMAN, IRIS, late of 13 Hunter Street, West Brunswick, widow, died 15th October, 1976.

MACKWELL, PRISCILLA GRACE, formerly of 29 Nightingale Street, St. Kilda, but late of 26 Millers Road, Altona, widow, died 17th June, 1976.

MONSSEN, JAMES JOHN, late of 50 Baroda Street, Ascot Vale, retired, died 18th November, 1976.

SCOTT-MCCULLOCH, RONALD LEONARD, late of Flat 4, 805 Princes Highway, Springvale, pastry cook, died 25th June, 1976.

SYMINGTON, JOHN THOMAS, late of 24 Hemmings Street, Dandenong, pensioner, died 16th December, 1976.

N. P. BRODY,  
Public Trustee.

168 Exhibition Street, Melbourne, 3000, 9th February, 1977.

NOTICE.

Creditors, next of kin, and others having claims against the estate of any of the under-mentioned deceased persons are required to send particulars of their claims to the Public Trustee, 256 Flinders Street, Melbourne, Vic. 3000, the personal representative, on or before the 25th April, 1977, after which date the Public Trustee may convey or distribute the assets having regard only to the claims of which the Public Trustee then has notice:—

CLARKE, MARY JANE, formerly of 34 Second Street, Black Rock, but late of "Centennial House", 15 Raleigh Street, Windsor, widow, died 28th October, 1976.

COOPER, STELLA MAY, late of 4 Mackay Street, Yarraville, widow, died 4th December, 1976.

CURTIS, DORIS MARY, also known as Curtis, Doris May, formerly of 7 Viva Street, Glen Iris, but late of Myola Private Hospital, 59 Serrell Street, East Malvern, widow, died 4th September, 1976.

HAYES, JOHN TIMOTHY, late of Queen Elizabeth Geriatric Centre, 102 Ascot Street South, Ballarat, died 7th September, 1976.

GATES, CHRISTINA ANNIE, late of 75 Clarence Street, East Brunswick, widow, died 30th August, 1976.

HENRY, PETER JOHN, formerly of Giffords Road, Warburton, but late of 526 Seesburg Street, Cape Woolamai, Phillip Island, retired Board of Works inspector, died 7th October, 1976.

HILLMAN, IRIS, late of 13 Hunter Street, West Brunswick, widow, died 15th October, 1976.

HUSSEY, HENRY ALLAN, late of Flat 1, 666 Main Road, Eltham, retired public servant, died 10th or 11th November, 1976.

HUTCHINSON, LUCY, late of 42 Marlborough Street, Balaclava, spinster, died 27th July, 1976.

JONES, MYFANWY SARAH, formerly of "Nangunyah", Ninth Street, Mildura, but late of Wheatley House Private Hospital, 97 Wheatley Road, McKinnon, spinster, died 15th November, 1975.

KENT, ALICE MAUDE, late of 67 Brunswick Road, East Brunswick, widow, died 5th October, 1976.

MACKWELL, PRISCILLA GRACE, formerly of 29 Nightingale Street, St. Kilda, but late of 26 Millers Road, Altona, widow, died 17th June, 1976.

MONSSEN, JAMES JOHN, late of 50 Baroda Street, Ascot Vale, retired, died 18th November, 1976.

PITHIE, ALEXANDER RAE, formerly of 91 Victoria Street, Footscray, but late of 191 Civic Parade, Altona, retired wire worker, died 20th October, 1976.

RUPPELL, CONRAD JOSEPH, also known as Conrad Joseph Ruppel, but late of 127 Main Street, Blackburn South, retired salesman, died 30th August, 1976.

SCOTT-MCCULLOCH, RONALD LEONARD, late of Flat 4, 805 Princes Highway, Springvale, pastry cook, died 25th June, 1976.

SPEARY, SYLVIA CLAUDINE, formerly of 6 Grace Street, Malvern, but late of Flat 13, 63 Hanmer Street, Williamstown, spinster, died 17th May, 1976.

SYMINGTON, JOHN THOMAS, late of 24 Hemmings Street, Dandenong, pensioner, died 16th December, 1976.

VAUSE, GEORGE ALFRED, late of Auckland, New Zealand, compositor, died 20th September, 1976.

WINESS, REGINALD SHAFTESBURY, late of 137 Collier Crescent, West Brunswick, retired turner and fitter, died 9th November, 1976.

Melbourne, 9th February, 1977.

N. P. BRODY,  
Public Trustee.

CONTRACTS ACCEPTED.—(Series 1976-77.)

AMENDMENTS.

Sched. No.	Item No.	Description.	Unit of Measurement.	New Rate	Contractor.	Effective Date.
		<b>Provisions.</b>		<b>\$</b>		
		<i>Gazette No. 54—3rd June, 1976.</i>				
1		<i>Provisions—Melbourne and Metropolitan District.</i>				
	38	Blend A Coffee, 4 kg ctn. . . . .	per kg	5.78	} Bushell's Pty. Ltd. . . . .	1.2.77
	39	" " " 25 kg chest . . . . .	"	5.76		
	40	" " " 45 kg . . . . .	"	5.76		
	41	Coffee, Instant, 50 g jar, "Pablo" . . . . .	per doz.	6.71		
	42	" " " 500 g . . . . .	"	60.93	} Kraft Foods Ltd. . . . .	7.2.77
	56	Vegemite "Kraft" 3 kg (was 6½-lb.) . . . . .	each	5.46		
	76	Apricots, dried 12.5 kg case . . . . .	per kg	3.66		
2		<i>Groceries—Melbourne and Metropolitan District.</i>				
	1	Baking Powder, 375 g . . . . .	per doz.	11.54	} Terra Self Service Pty. Ltd. . . . .	4.2.77
	3	Strawberry "Quick", 500 g . . . . .	"	10.16		
	4	Biscuits, Dry, Salada, 1.4 kg . . . . .	each	2.28		
	5	" Sweet, Milk Arrowroot 2.6 kg . . . . .	"	3.80		
	6	" Assorted, 3.5 kg . . . . .	"	5.65		
	25	Candles "Conotes" . . . . .	per doz.	1.05		
	30	Rice, Dressed, 25 kg bag, Sunwhite . . . . .	each	13.64		
	31	Cheddar Cheese, 250 g pkts. "Kraft" . . . . .	per doz.	6.18		
	32	" " 2 kg boxes . . . . .	per box	3.87		
	33	" Grated, 1.5 kg "Kraft" . . . . .	each	6.07		
	36	Coffee Essence, 250 ml . . . . .	per doz.	6.70		
	37	" " 500 ml . . . . .	"	12.41		
	38	" " 5 litre . . . . .	each	8.98		
	39	" Instant, 100 g tins "Inter. Roast" . . . . .	per doz.	18.40		
	40	" " 150 g jars "Pablo" . . . . .	"	21.94		
	46	Custard Powder, 500 g "Cameo" . . . . .	"	4.60		
	60	Bonox, 115 g . . . . .	"	5.76		
	61	" 230 g . . . . .	"	9.34		
	62	" 910 g . . . . .	each	2.50		
	66	Tomato Paste, 905 g . . . . .	per doz.	18.12		
	68	Vegemite, 115 g . . . . .	"	4.66		
	69	" 235 g . . . . .	"	8.18		
	73	Fish tinned, Tuna, 426 g . . . . .	"	14.68		
	79	Apricots, Plain—dry . . . . .	per kg	3.66		
	116	Mushroom Booster, 650 kg . . . . .	each	3.74		
	134	Mayonnaise, 145 g . . . . .	per doz.	3.68		
	141	Monosodium Glutamate, 650 g . . . . .	each	2.87		
	151	Pepper, Cayenne, 500 g . . . . .	"	1.23		
	164	Sauce, Worcestershire, 540 ml . . . . .	per doz.	6.82		
	177	Sugar, Castor, 2 kg . . . . .	each	0.90		
	178	" Icing, 2 kg . . . . .	"	0.90		
	182	Baked beans, 445 g . . . . .	per doz.	3.60		
	193	Vinegar "Vines", 750 ml . . . . .	"	3.36		
6		<i>Provisions—Ararat District, Sub-Schedule No. 4—Groceries.</i>				
	3	Beetroot 450 g (was 425 g) . . . . .	per doz.	3.22	} McKay MacLeod Pty. Ltd. . . . .	3.2.77
	36	Pepper, Ground, White, 500 g . . . . .	each	2.37		
	54	Coconut, 1.2 kg . . . . .	"	2.09		
7		<i>Provisions—Ballarat District, Sub-Schedule No. 4—Groceries for Teachers College Hostels.</i>				
	4	Biscuits, Malt . . . . .	per tin	5.46	} McKay MacLeod Pty. Ltd. . . . .	3.2.77
	9	Cheese, "Kraft" Cheddar, 2.5 kg . . . . .	each	4.98		
		" " " 250 g . . . . .	per doz.	6.47		
	13	Coconut, 1.2 kg . . . . .	each	2.05		
	27	Vegemite, 455 g jar . . . . .	per doz.	14.38		
		" " 235 g . . . . .	"	8.55		
		" " " . . . . .	"	4.47		
	30	Bloater Paste "Pecks" . . . . .	"	4.47		
	31	Salmon and Shrimp Paste "Pecks" . . . . .	"	4.47		
	46	Solid Pack Peaches, No. 10 cans . . . . .	"	26.86		
	57	Junket Tablets . . . . .	"	3.70		
	78	Ground White Pepper, 500 g . . . . .	each	2.35		
	80	Rice, 25 kg bag . . . . .	"	14.74		
	81	Rice, Ground . . . . .	per doz.	2.88		
	101	Tomato Soup, 432 g tins . . . . .	"	3.92		
	110	Tea, 5 kg . . . . .	each	11.17		
	115	Baked Beans, 454 kg tins . . . . .	per doz.	4.23		

AMENDMENTS.—continued.

Sched. No.	Item No.	Description.	Unit of Measurement.	New Rate.	Contractor.	Effective Date.
		<b>Provisions—continued.</b>		<b>\$</b>		
7		<i>Provisions—Ballarat District, Sub-Schedule No. 5—Groceries for Lakeside Hospital.</i>				
	4	Baked Beans .. .. .	per doz.	4.23 <sup>1</sup>	} McKay MacLeod Pty. Ltd.	3.2.77
	25	Junket tablets .. .. .	"	3.70		
	32	Pepper, Ground, Black, 500 g .. .. .	each	2.35		
	47	Spaghetti and Tomato Sauce, 432 g .. .. .	per doz.	4.23		
17		<i>Provisions—Langi Kal Kal Training Centre—Sub-Schedule No. 1—Breadstuffs.</i>				
		Change of Contractor :—				
		Delete—Local Maid Bread				
		Substitute—Sunicrust Bakeries Pty. Ltd.				
		Rates remain the same				
		31.12.76				
21		<i>Provisions—Pleasant Creek Special School, Stawell. Sub-Schedule No. 4—Groceries.</i>				
	7	Coconut, 1.2 kg .. .. .	each	2.12	} McKay MacLeod Pty. Ltd.	3.2.77
	19	Junket tablets .. .. .	per doz.	3.79		
	23	Ground black pepper, 500 g .. .. .	each	2.38		
		<b>General Stores.</b>				
		<i>Gazette No. 58—10th June, 1976.</i>				
3		<b>Batteries.</b>				
		Batteries to suit—				
	1	Automotive, truck, tractor, etc.	each	Lucas Trade Price List	} Lucas Industries Aust. Ltd.	1.2.77
	2	Radio and home lighting plants .. .. .	"	1.1.77 Less 25% discount		
37		<b>Electrical Goods.</b>				
		Lamps, Gas filled (clear or inside frosted as ordered)—				
	1	240 volts, 25 watts B.C./E.S. .. .. .	each	0.2425	} Thorn Industries Lighting P/L	24.1.77
	2	" " 40 " " .. .. .	"	0.2425		
	3	" " 60 " " .. .. .	"	0.2425		
	4	" " 75 " " .. .. .	"	0.2475		
	5	" " 100 " " .. .. .	"	0.2475		
	6	" " 150 " " —80 mm .. .. .	"	0.3975		
	7	" " 150 " " —70 mm .. .. .	"	0.3975		
	8	" " 200 " " .. .. .	"	0.4000		
	9	" " 300 " " G. E. Clear .. .. .	"	0.8375		
	10	" " 500 " " .. .. .	"	2.02		
		Lamps, Pilot—				
	11	240 volts, 15 watts, B.C./E.S. Red .. .. .	"	0.1650	} Thorn Industries Lighting P/L	24.1.77
	12	" " 15 " " Clear .. .. .	"	0.3325		
		Lamps Reinforced Construction—				
	13	240 volts, 40 watts, B.C./E.S. .. .. .	"	0.26	} Thorn Industries Lighting P/L	24.1.77
	14	" " 60 " " .. .. .	"	0.26		
		Fluorescent Lamps and Auxiliaries tubes—				
	15	250 volts, 65 watts .. .. .	"	1.47	} Thorn Industries Lighting P/L	24.1.77
	16	" " 40 " " .. .. .	"	0.8975		
	17	" " 20 " " .. .. .	"	0.8275		
	19	" " 40 " " .. .. .	"	0.8975		
	20	" " 20 " " .. .. .	"	0.8275		
	54	Washing Machine with power wringer and heating element, "Simpson Standard"—Model No. 11-023 .. .. .	"	215.61	Simpson Pope Ltd.	17.1.77
	56	Washing Machine, Twin tub, make Lightburn. Model Kingsize Extra Heavy duty 200AS .. .. .	each	444.85	Lightburn Products Ltd.	1.2.77
	57	Washing Machine, Semi automatic without heating element, "Simpson Minimatic"—Model No. 43-112 (was 43-012) .. .. .	"	274.50	Simpson Pope Ltd.	17.1.77
	60	Tape, Adhesive, 3/4" x 25 yds .. .. .	"	0.35	GEC-AEI (Aust.) P/L	18.1.77
46		<b>Hose, Sheeting, etc.</b>				
	22	Hose, 1/2" bore pressure spray .. .. .	per ft.	0.70	Durance Industrial Rubber Supplies P/L	8.2.77

AMENDMENTS.—continued.

Sched. No.	Item No.	Description.	Unit of Measurement.	New Rate.	Contractor.	Effective Date.
		<b>General Stores—continued.</b>		\$		
		<i>Cleaning and Polishing Requirements.</i>				
64	31	Buckets, Galvanized, 9 litre capacity	each	3.05	B. and R. Domestic Homewares Pty. Ltd.	2.2.77
	32	" " 18 " "	"	5.12		
		Rubbish bins, heavy duty, galvanised—				
	35	No. 3	"	7.42		
	36	No. 4	"	8.80		
	37	No. 5	"	13.05		
52		<b>Tools (General).</b>				
		<i>Gazette No. 36—2nd April, 1976.</i>				
	1	Auger Screws:—			A. J. Calder Industrial Supplies	18.1.77
		$\frac{1}{4}$ "	each	1.80		
		$\frac{3}{8}$ "	"	1.80		
		$\frac{1}{2}$ "	"	1.80		
		$\frac{5}{8}$ "	"	1.80		
		$\frac{3}{4}$ "	"	1.84		
		$\frac{7}{8}$ "	"	2.09		
		1"	"	2.09		
		$1\frac{1}{8}$ "	"	2.33		
		$1\frac{1}{4}$ "	"	2.33		
		$1\frac{3}{8}$ "	"	2.81		
		$1\frac{1}{2}$ "	"	2.81		
		$1\frac{3}{4}$ "	"	2.99		
		1"	"	2.99		
		$1\frac{1}{4}$ "	"	3.14		
		$1\frac{1}{2}$ "	"	3.52		
	15	Hacksaw blades—			Eagle and Globe Steel Ltd.	19.1.77
		10" × 18 TPI	per doz.	1.32		
		10" × 24 "	"	1.32		
		10" × 32 "	"	1.32		
		12" × 18 "	"	1.38		
		12" × 24 "	"	1.38		
	16	Hacksaw blades, power—12" × 1" × .050 × 14T	per 100	135.22		
		" " " —14" × 1" × .050 × 14T	"	157.75		
	28	Chisel, Cold, half round—			A. J. Calder	18.1.77
		6" × $\frac{1}{4}$ " × $\frac{1}{4}$ "	each	1.24		
		7" × $\frac{3}{8}$ " × $\frac{1}{8}$ "	"	1.54		
	30	Chisel, Diamond Point—			A. J. Calder	18.1.77
		6" × $\frac{1}{4}$ " × $\frac{1}{4}$ "	"	1.24		
		7" × $\frac{3}{8}$ " × $\frac{1}{8}$ "	"	1.54		
	45	Dressers, mechanical—			McPherson's Ltd.	7.2.77
		0	each	4.00		
		1	"	5.53		
		2	"	8.43	McPherson's Ltd.	1.2.77
	46	No. 3 "Ixion" hand drill	"	10.78		
	47	Breast Drill	"	15.61		
	126	Nail Punch Set, "Millers Falls"	per set	2.05	McPherson's Ltd.	1.2.77
	147	Hand Saw, 26" "Disston K6"	each	8.11		
	150	Panel Saw 22"	"	7.38		
	160	Sets and headed Rivet—			A. J. Calder	18.1.77
		$\frac{1}{4}$ "	each	2.03		
		$\frac{3}{8}$ "	"	2.03		
	167	Spanners, all types and sizes	Dowidat List	18.12.76		
			Price List	Less 33 $\frac{1}{4}$ % discount		
	170	Squares, Rosewood—			A. J. Calder	18.1.77
		6"	each	3.99		
		9"	"	4.20		
		12"	"	5.45		
	221	Hedge Shear	"	6.06		
	239	Spade D. H. No. 2465	"	6.60		
	306	Axe Stone	"	1.43		
	309	Tape measure—14 mm × 10 m	"	4.68	A. J. Calder	18.1.77
		" " 14 mm × 20 m	"	6.78		
		" " 14 mm × 30 m	"	9.18		
	310	Tape measure, steel—			A. J. Calder	18.1.77
		13 mm × 10 m	each	6.33		
		13 mm × 20 m	"	8.06		
		13 mm × 30 m	"	10.25		
	318	Silver Brazing Alloys $\frac{3}{32}$ " .008	per kg	168.70		
	319	" Solder, SBA 250	"	95.85		
	320	" " SBA 242	"	79.08		

AMENDMENTS—continued.

Sched. No.	Item No.	Description.	Unit of Measurement.	New Rate.	Contractor.	Effective Date.		
56		<b>Motor Spirit, Kerosene, Fuel Oils and Lubricants.</b> <i>Gazette No. 29—15th March, 1976.</i>		\$				
	23	Power Kerosene in 200 litre drums— Delete prices quoted since 1.11.76 and insert the following—	per litre	0.08 0.086	} B.P. Australia Ltd.	{ 1.11.76 21.12.76		
	23	Power Kerosene in 200 litre drums	"	0.0891			} <i>Cancel : B.P. Australia Ltd. Substitute : Mobil Oil Aust. Ltd.</i>	{ 25.1.77 12.2.77
	31	Bunker Fuel (for Marine Use) Rates for this item are as follows—	per tonne	89.30 87.19 85.64 95.93 83.06 83.01 87.16	} B.P. Australia Ltd.	{ 1.12.76 8.12.76 15.12.76 17.12.76 1.1.77 1.2.77 3.2.77		
1		<b>Requisites (Junior School) Education Department.</b> <i>Gazette No. 74—4th August, 1976.</i>						
	9	Beads, Hard Gloss Plastic, 100 per pkt...	per pkt.	0.43			} Meribee Trading Co...	3.12.76
	10	Laces, Plastic, in boxes of 25 ..	"	0.42				
	11	Tablets, Plastic, 100 per pkt. ..	"	0.67				
73		<b>Dictation Equipment.</b> <i>Gazette No. 83—8th September, 1976.</i>						
	2A	Dictation Machine "National RQ212S"	each	67.00			Natsound Pty. Ltd.	25.1.77

W. L. ROBERTSON,  
Secretary to the Tender Board.

**ORDERS IN COUNCIL.—(Series 1976-77).**  
**PUBLIC WORKS.**

His Excellency the Governor of the State of Victoria by and with the advice of the Executive Council thereof, doth by Order made on the 8th day of February, 1977, approve of the acceptance by the Minister of Public Works of the under-mentioned offers without public tenders being invited:—

762. Collingwood Technical College, supply of student combination desks by N. P. Hauffe and Co. for the sum of Fourteen thousand eight hundred and five dollars (\$14,805.00).—(S.132233.)

763. Education Department, 80 Collins Street, provision of mobile screens by Framac Commercial Furniture Pty. Ltd., for the sum of Forty-four thousand four hundred dollars (\$44,400.00).—(S.133029.)

764. Knox, Education Department Directorate, maintenance of mechanical equipment for the sum of Eighteen thousand seven hundred and ninety-two dollars (\$18,792.00).—(N.V.57759.)

TOM FORRISTAL,

Clerk of the Executive Council.

At the Executive Council Chamber,  
Melbourne, 8th February, 1977.

**APPOINTMENTS AND RESIGNATIONS**

**APPOINTMENTS.**

His Excellency the Governor of the State of Victoria, by and with the advice of the Executive Council thereof, has, by Orders made on the 8th day of February, 1977, been pleased to make the undermentioned appointments, viz.:—

**DEPARTMENT OF CROWN LANDS AND SURVEY.**

*Bailiffs of Crown Lands.*

ALAN MAXWELL BRUTON,  
IAN ANTHONY MADDISON, and  
ALBERT LAURIER,  
all officers of the National Parks Service (Ministry for Conservation), to be Bailiffs of Crown lands, without additional salary, with respect to the Crown lands in the

Parishes of Tarragal, Mouzie, Kentbruck, Warrain and Glenelg temporarily reserved for Public Purposes (Recreation and Conservation of the Native Flora and Fauna and Natural Features) by Order in Council of the 14th September, 1976, and with authority to discharge and exercise all the duties and powers of bailiffs.

*Member of Elsternwick Park Committee of Management.*

DIANE MARGARET LOPEZ

to be a member of the Committee of Management of the Crown lands in the Parish of Prahran known as "Elsternwick Park", in the place of Irene Dunsmuir, who is no longer a Councillor of the said City, pursuant to the provisions of section 220 (1) of the Land Act 1958 and upon application by the Minister of Lands and the Mayor, Councillors and Citizens of the City of Brighton: Provided that the said Diane Margaret Lopez shall hold office as a member of the Committee of Management for so long only as she continues to be a Councillor and the elect of the Council of the City of Brighton.

**DEPARTMENT OF HEALTH.**

*Superintendent, Traralgon Psychiatric Hospital and Mental Hospital.*

ALEXANDER FRANK JOHN BELL, M.B., B.S., D.P.M., M.R.C.Psych.,

to be Superintendent, Traralgon Psychiatric Hospital and Mental Hospital, pursuant to the provisions of section 26 (1) of the Mental Health Act 1959, vice Dr. R. Martin, resigned.

*Superintendent, Kew Mental Hospital.*

RODERICK MAILER AITCHISON, M.B., B.S., D.P.M., to be Superintendent, Kew Mental Hospital, pursuant to section 26 (1) of the Mental Health Act 1959, vice Dr. C. G. Burt, retired.

*Deputy Superintendents of Hospitals.*

JENNIFER ANN BARRON, M.B., C.L.B., M.A.N.Z.C.P., to be Deputy Superintendent, Bendigo Psychiatric Hospital and Mental Hospital, pursuant to section 26 (1) of the Mental Health Act 1959, vice Dr. V. Ashburner, retired.

DHRUBA DEV BHATTACHARYYA, M.B., B.S., D.P.M., M.A.N.Z.C.P., to be Deputy Superintendent, Beechworth Mental Hospital and Training Centre, pursuant to section 26 (1) of the *Mental Health Act 1959*.

ROBERT VICTOR DELAFORCE, M.B., B.S., M.A.N.Z.C.P., to be Deputy Superintendent, Brierley Hospital, Warrnambool, pursuant to section 26 (1) of the *Mental Health Act 1959*, vice Dinesh Parekh, transferred.

JAN PETER HARDENBERG (M.D. Utrecht), M.A.N.Z.C.P., L.R.C.P., L.R.C.S., to be Deputy Superintendent, Kew Mental Hospital, pursuant to section 26 (1) of the *Mental Health Act 1959*, vice Dr. R. M. Aitchison, promoted.

*Superintendent and Deputy Superintendent, Royal Park Psychiatric Hospital.*

WILLIAM RICHARD MCLEOD, M.B., B.S., M.D., B.A., D.P.M., M.A.N.Z.C.P., M.R.C. Psych., M.R.A.C.P., to be Superintendent, Royal Park Psychiatric Hospital, pursuant to section 26 (1) of the *Mental Health Act 1959*, vice Dr. E. Chiu, resigned.

WALIMUNI CHANDRA PADMANATHA DE SILVA WIJESINGHE, M.B., B.S., M.A.N.Z.C.P., to be Deputy Superintendent, Royal Park Psychiatric Hospital, pursuant to section 26 (1) of the *Mental Health Act 1959*, vice Dr. H. P. Chopra.

*Government Appointees on Committees of Management of Hospitals.*

WILLIAM FRANCIS MCCONACHY to be Government Appointee on Committee of Management of the Lorne Community Hospital for a period of three years commencing on the 26th February, 1977.

STANLEY WILLIAM WALDRON to be Government Appointee on Committee of Management of the Skipton and District Memorial Hospital for a period of three years commencing on the 27th February, 1977.

JOHN TASMAN EMERSON to be Government Appointee on Committee of Management, McCulloch House, Clayton, for the remainder of the period ending 6th May, 1977.

ROBERT STEWART DONALD to be Government Appointee on Committee of Management of the Casterton Memorial Hospital for a period of three years commencing on the 11th February, 1977.

KENNETH IAN HAMILTON to be Government Appointee on Committee of Management of the Rupanyup and District Hospital for a period of three years commencing on the 26th February, 1977.

HENRY DONALD HUTCHINS to be Government Appointee on Committee of Management of the Oakleigh District Community Hospital for a period of three years commencing on the 21st February, 1977, pursuant to the provision of section 48 (1) (a) (ii) of the *Hospitals and Charities Act 1958*.

LAW DEPARTMENT.

*Justices of the Peace.*

WILLIAM GEORGE ARMSTRONG, Murtoa, FRASER RONALD LAIDLAW, "Bajanna", Strathmerton, STUART WILLIAM MOODIE, High Street, Bannockburn to be Justices of the Peace for the State of Victoria.

*Commissioners for Taking Declarations, &c.*

JAMES RONALD ARCHIBALD, 10 Janus Street, Tullamarine, ERNESTINE LUCILLA CLARKE, and GWENYTH LOUISE SANDERS, 179 Queen Street, Melbourne, MICHAEL JOHN COOK, 226 Swanston Street, Melbourne, LEON MICHAEL FLEGELTAUB, Grattan Street, Parkville, KENNETH GEORGE HAMMOND, High Street, Broadford, HELEN KUZAR, 150 Lonsdale Street, Melbourne, PETER MICHAEL LEONARD, 136 Cotham Road, Kew, JAMES LEON MCNAMARA, 13 Albert Terrace, Belmont, ALFRED CHARLES MACLAREN, 211 Sturt Street, South Melbourne, BENJAMIN WILLIAM SANDARS, 124 La Trobe Street, Melbourne, MARK IRVINE WEBB STENSON, 258-264 Little Bourke Street, Melbourne, PETER JEFFREY TAYLOR, 17 Ainsdale Avenue, Wantirna South, and

PETER ALBERT GEORGE WEAVING, 500 Collins Street, Melbourne, to be Commissioners for taking Declarations and Affidavits under the *Evidence Act 1958*.

MINISTRY OF WATER RESOURCES.

*Waterworks Trust Commissioners.*

GEORGE HENRY DOUGLAS TELFER to be a Commissioner of the Lindenow Waterworks Trust, to hold such position for a period of four years from the date hereof, subject to the provisions of the Water Act.

BARRY MICHAEL COSTIGAN to be a Commissioner of the Shire of Tungamah Waterworks Trust, to hold such position for a period of four years from the date hereof, subject to the provisions of the Water Act.

NEIL ROBERT TURNBULL, and JOHN RICHARD MCMANUS, to be Commissioners of the Rokewood Waterworks Trust, to hold such position for a period of four years from the date hereof, subject to the provisions of the Water Act.

*Improvement Trust Commissioner.*

ALBERT RONALD NICOLL to be a Commissioner of the Ovens River Improvement Trust, to hold such position for a period of four years from the date hereof, subject to the provisions of the River Improvement Act.

*Sewerage Authority Members.*

WILLIAM GEORGE BUTCHER, WILLIAM FRANCIS COAD, and ROBERT COLLIER, to be Members of the Sea Lake Sewerage Authority, to hold office as such for a period of four years from the date hereof, subject to the provisions of the Sewerage Districts Act.

TOM FORRISTAL, Clerk of the Executive Council.

At the Executive Council Chamber, Melbourne, 8th February, 1977.

MENTAL HEALTH ACT 1959, SECTION 26.

Notice is hereby given that the following appointments have been made pursuant to section 26 of the *Mental Health Act 1959*.

COLIN EUGENE HAY, Manager, Royal Park Psychiatric Hospital, vice A. J. McDonald transferred.

ALLAN JOSEPH McDONALD, Manager, Mont Park Psychiatric and Mental Hospital, vice K. A. Boyd promoted.

DESMOND FRANCIS PURCELL, Deputy Manager, Kew Mental Hospital, vice T. G. Cash, transferred.

G. W. ROGAN, Secretary, Department of Health, 4th February, 1977.

*Liquor Control Act 1968.*

APPOINTMENT OF LICENSING-INSPECTORS.

In accordance with the authority conferred upon me by sub-section (1) of Section 22 of the *Liquor Control Act 1968*, I, Reginald Jackson, Chief Commissioner of Police, hereby appoint the following Officers of Police as Licensing Inspectors for the Divisions of the Police Districts as shown:—

Division Number.	Police District.	Rank and Name.
3	Dandenong	Inspector Peter John Dunn (from 1.3.77 to 31.3.77).
4	Dandenong	Inspector Robert Quentin Broughton (from 13.2.77 to 5.3.77).
3	Prahran	Inspector Barry Lewis Page (from 6.2.77 to 26.2.77).

10.2.1977

R. JACKSON, Chief Commissioner of Police.

**RESIGNATIONS.**

His Excellency the Governor of the State of Victoria, by and with the advice of the Executive Council thereof, has, by Order made on the 8th day of February, 1977, accepted the resignations of the persons named hereunder of the office mentioned, viz.:—

LAW DEPARTMENT.  
Justices of the Peace.

DONALD CHESTER, and  
WILLIAM GREY MANIFOLD,  
as Justices of the Peace for the State of  
Victoria.

TOM FORRISTAL,  
Clerk of the Executive Council.

At the Executive Council Chamber,  
Melbourne, 8th February, 1977.

**ORDERS IN COUNCIL**

**LAND ACT 1958.**

At the Executive Council Chamber, Melbourne, the  
eighth day of February, 1977.

PRESENT:

His Excellency the Governor of Victoria.  
Mr. Borthwick | Mr. Houghton.

**VESTING OF LAND IN THE VICTORIAN RAILWAYS BOARD.**

His Excellency the Governor of the State of Victoria by and with the advice of the Executive Council thereof, doth by this Order made pursuant to section 22A (2) of the Land Act 1958 vest in the Victorian Railways Board the land shown by hatching on the plan annexed hereto.

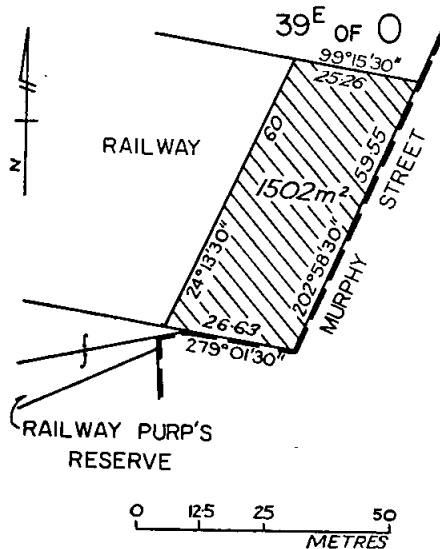

And the Honorable William Archibald Borthwick, Her Majesty's Minister of Lands for the State of Victoria, shall give the necessary directions herein accordingly.

TOM FORRISTAL,  
Clerk of the Executive Council.

**LAND ACT 1958.**

At the Executive Council Chamber, Melbourne, the  
eighth day of February, 1977.

PRESENT:

His Excellency the Governor of Victoria.  
Mr. Borthwick | Mr. Houghton.

His Excellency the Governor of the State of Victoria by and with the advice of the Executive Council thereof, doth by this Order made pursuant to section 22A (4) (a) of the Land Act 1958 amend the Second Schedule of the Geelong Harbor Trust Act 1958 by the excision therefrom of the portion containing 9.553 hectares indicated by hatching on plan annexed hereto.—M.199(5A) (G.76489).

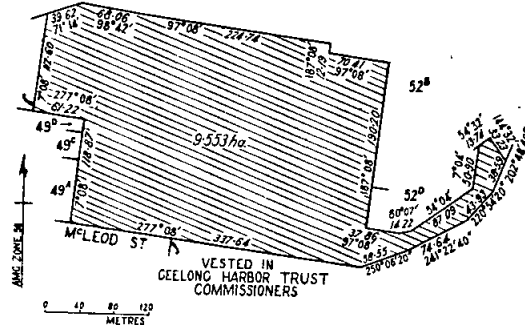

And the Honorable William Archibald Borthwick, Her Majesty's Minister of Lands for the State of Victoria, shall give the necessary directions herein accordingly.

TOM FORRISTAL,  
Clerk of the Executive Council.

**LAND ACT 1958.**

At the Executive Council Chamber, Melbourne, the  
eighth day of February, 1977.

PRESENT:

His Excellency the Governor of Victoria.  
Mr. Borthwick | Mr. Houghton.

**LAND PERMANENTLY RESERVED AS A SITE.**

His Excellency the Governor of the State of Victoria, by and with the advice of the Executive Council thereof, pursuant to the provisions of sections 14 and 21 of the Land Act 1958, hereby reserves permanently from sale, from being leased and from having a licence granted in respect thereof, and also except from occupation for mining purposes under any miner's right, the Crown lands hereinafter described, viz.:—

KALADBRO.—Site for Public Purposes (Conservation of Wildlife); 126.4 hectares, being Crown Allotment 70D, Parish of Kaladbro, County of Follett, being the site temporarily reserved therefor by Order in Council of the 12th October, 1976.—(K.153(8)) (Rs.10291).

And the Honorable William Archibald Borthwick, Her Majesty's Minister of Lands for the State of Victoria, shall give the necessary directions herein accordingly.

TOM FORRISTAL,  
Clerk of the Executive Council.

**DEPARTMENT OF CROWN LANDS AND SURVEY.**

At the Executive Council Chamber, Melbourne, the  
eighth day of February, 1977.

PRESENT:

His Excellency the Governor of Victoria.  
Mr. Borthwick | Mr. Houghton.

**VESTING OF LAND IN THE GRAIN ELEVATORS BOARD.**

His Excellency the Governor of the State of Victoria by and with the advice of the Executive Council thereof, doth by this Order made pursuant to the provisions of



section 22A (2) of the Land Act 1958, vest in the Grain Elevators Board the land comprising 4530 square metres being Crown allotment 52E in the Parish of Moorpanyal, County of Grant as shown by hatching on plan hereunder.—(M.199(5A) (G.76489).

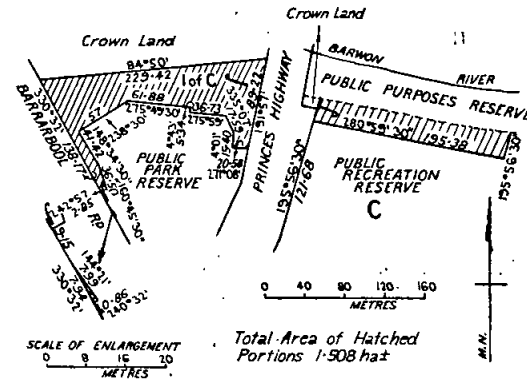
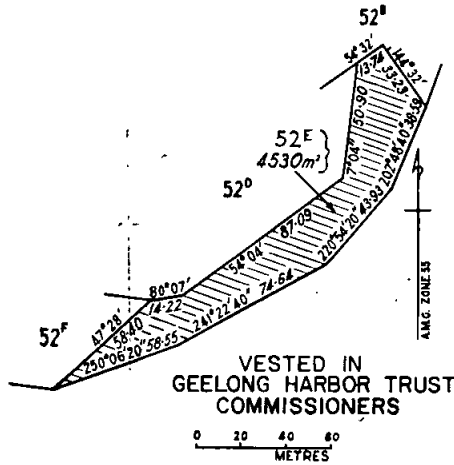

And the Honorable William Archibald Borthwick, Her Majesty's Minister of Lands for the State of Victoria, shall give the necessary directions herein accordingly.

TOM FORRISTAL,  
Clerk of the Executive Council.

Land Act 1958.  
DEPARTMENT OF CROWN LANDS AND SURVEY.

At the Executive Council Chamber, Melbourne, the eighth day of February, 1977.

PRESENT:  
His Excellency the Governor of Victoria.  
Mr. Borthwick | Mr. Houghton.

LANDS TEMPORARILY RESERVED AS SITES.

His Excellency the Governor of the State of Victoria, by and with the advice of the Executive Council thereof, doth hereby in pursuance of the provisions of section 14 of the Land Act 1958, reserve temporarily from sale, from being leased and from having a licence granted in respect thereof, and also except from occupation for mining purposes under any miner's right the lands hereinafter described, viz.:

CANN RIVER.—Site for Public Purposes (Show Ground and Public Recreation); 2,434 hectares, being Crown allotment 31, section 14, Township of Cann River, Parish of Noorinbee, County of Croajingolong as indicated by hatching on plan hereunder.—(N.156(5) (Rs.4041).

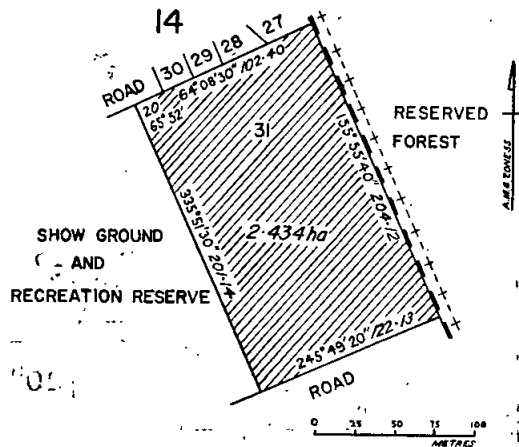

WONTHAGGI.—Site for Water Supply purposes, 3,136 hectares, being Crown allotment 1, section 109, Township of Wonthaggi, Parish of Wonthaggi, County of Mornington, as indicated by hatching on plan hereunder.—(W.345(10) (Rs.9957).

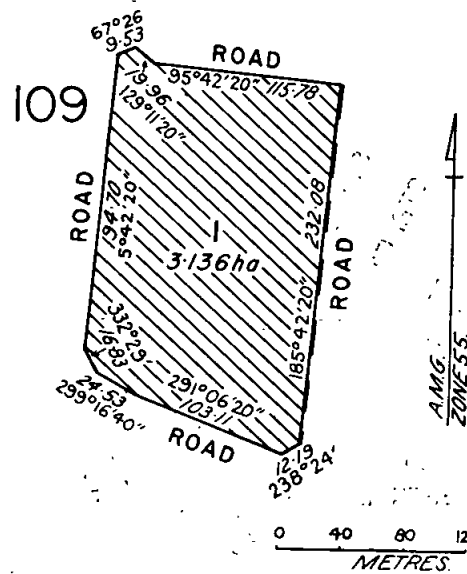

And the Honorable William Archibald Borthwick, Her Majesty's Minister of Lands for the State of Victoria, shall give the necessary directions herein accordingly.

TOM FORRISTAL,  
Clerk of the Executive Council.

DEPARTMENT OF CROWN LANDS AND SURVEY.

At the Executive Council Chamber, Melbourne, the eighth day of February, 1977.

PRESENT:

His Excellency the Governor of Victoria.  
Mr. Borthwick | Mr. Houghton.

UNUSED ROADS CLOSED.

His Excellency the Governor of the State of Victoria, by and with the advice of the Executive Council thereof, and the concurrence in writing of the Council of the municipality concerned, doth hereby direct that in pursuance of the provisions of section 349 of the Land Act 1958, the unused roads referred to hereunder be closed, viz.:

Township of Stawell, Parish of Stawell, County of Borung, being the road indicated by hatching on plan hereunder.—(S.329<sup>(12)</sup>). (W.91508).

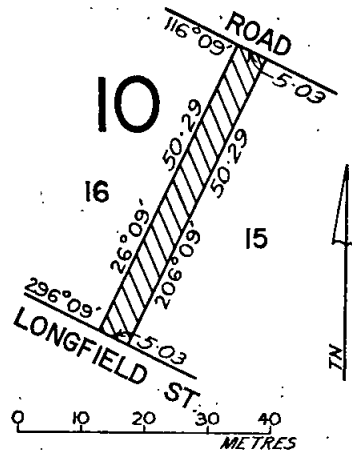

Parish of Koyuga, County of Rodney, being the road indicated by hatching on plan hereunder.—(K.98<sup>(6)</sup>). (W.90831).

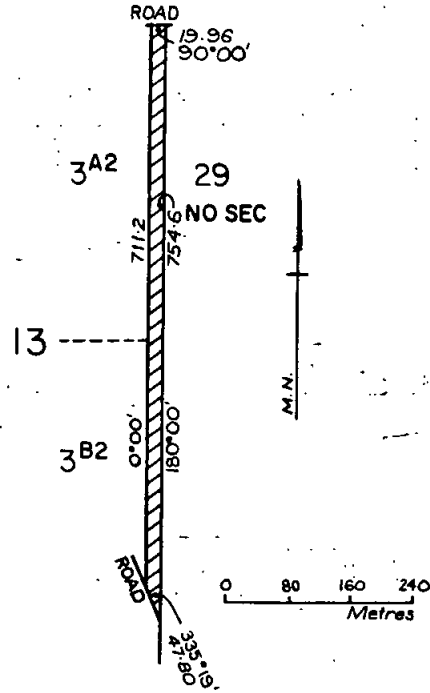

Township of Heathcote, Parish of Heathcote, County of Dalhousie, being the portion of road indicated by hatching on plan hereunder.—(H.74<sup>(7)</sup>). (L.6/1081).

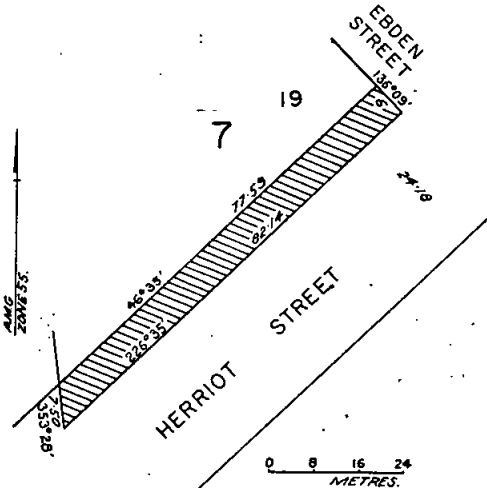

Township of Yackandandah, Parish of Yackandandah, County of Bogong, being the road indicated by hatching on plan hereunder.—(Y.45<sup>(17)</sup>). (HO.35808).

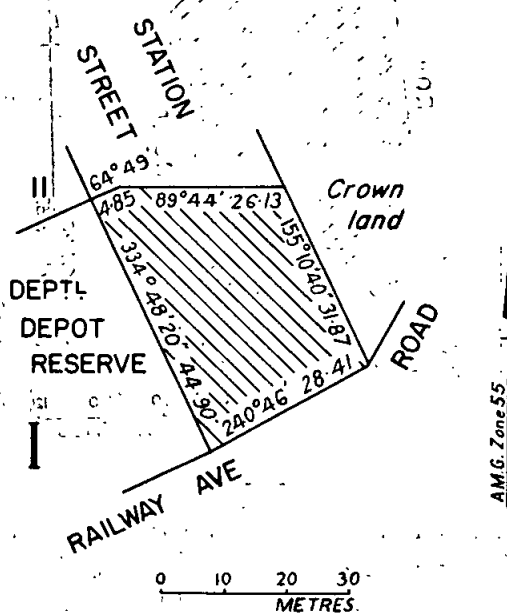

Parish of Burke, County of Talbot, being the road indicated by hatching on plan hereunder.—(B.515<sup>(4)</sup>). (W.91895).

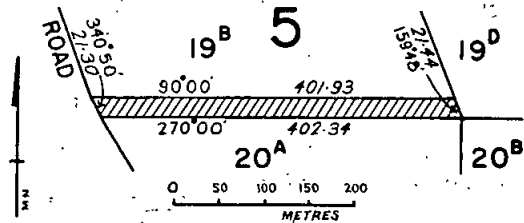

Parish of Boorolite, County of Wonnangatta, being the road indicated by hatching on plan hereunder.—(B.642<sup>(8)</sup>) (H.O.35508).

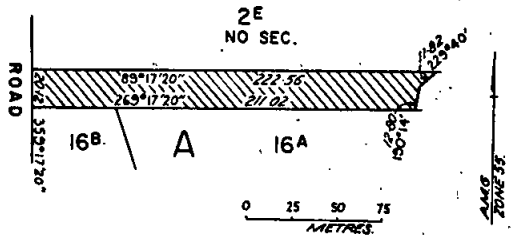

Parish of Bingo-Munjie North, County of Bogong, being the road indicated by hatching on plan hereunder.—(B.596<sup>(9)</sup>) (L.9-1053).

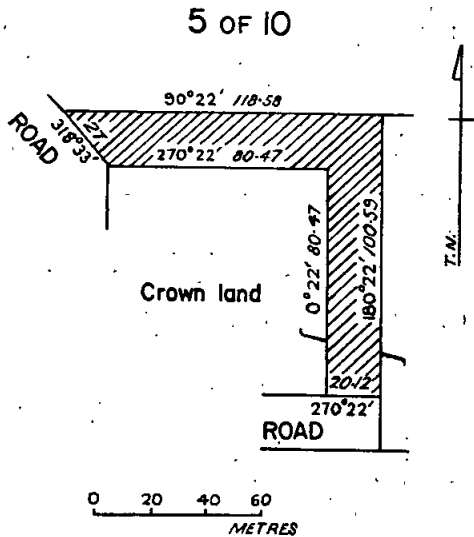

Township of Powelltown, Parish of Beenak, County of Evelyn, being the road indicated by hatching on plan hereunder.—(P.188<sup>(2)</sup>) (O.786A/134).

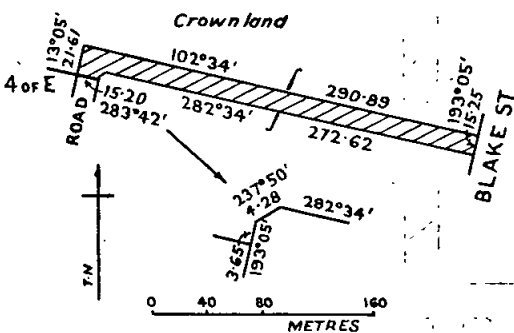

And the Honorable William Archibald Borthwick, Her Majesty's Minister of Lands for the State of Victoria, shall give the necessary directions herein accordingly.

TOM FORRISTAL,  
Clerk of the Executive Council.

LOCAL GOVERNMENT DEPARTMENT.

At the Executive Council Chamber, Melbourne, the eighth day of February, 1977.

PRESENT:

His Excellency the Governor of Victoria,  
Mr. Borthwick | Mr. Houghton.

PART OF ROAD DISCONTINUED.—CITY OF CAULFIELD.

Whereas it is provided in section 528 (2) of the Local Government Act 1958, that where a road (whether or not a public highway but not being a road set out on land of the Crown) or any part thereof is not required for public use, the Governor in Council on the request of the council of the municipality in which such road is situated made not less than one month after publishing in a newspaper generally circulating in the district and posting to the registered proprietor (if any) of the land and the owners and occupiers (if any) of lands abutting or immediately adjacent to the road notice of intention to make such request may by Order published in the Government Gazette direct that such road or part shall be discontinued and thereupon such road or part shall be discontinued accordingly.

And whereas the Council of the City of Caulfield has requested that the Governor in Council direct that a part of a road off Bambrā Road, Caulfield be discontinued and not less than one month previously has published in a newspaper generally circulating in the district and posted to the registered proprietor of the land in the part of the road and the owners and occupiers of land abutting or immediately adjacent to the said part of a road notice of intention to make such request:

Now therefore, His Excellency the Governor of the State of Victoria, by and with the advice of the Executive Council thereof, hereby directs:—

- (a) that the said part of a road which is shown by hachure on the plan hereunder shall be discontinued;
- (b) that notwithstanding such discontinuance the Melbourne and Metropolitan Board of Works shall continue to have and possess the same right title power authority or interest in or in relation to the whole of the land shown by hachure on the said plan as it had or possessed prior to such discontinuance with respect to or in connection with any drains or pipes laid or erected in on or over such lands for the purposes of drainage or sewerage;
- (c) that notwithstanding such discontinuance the Council of the City of Caulfield shall continue to have and possess the same right title power authority or interest in or in relation to the whole of the land shown by hachure on the said plan as it had or possessed prior to such discontinuance with respect to or in connection with any drains or pipes laid or erected in on or over such land for purposes of drainage; and
- (d) that, subject to any such right title power authority or interest the land in the said part of a road may be sold by the Council of the City of Caulfield by agreement.

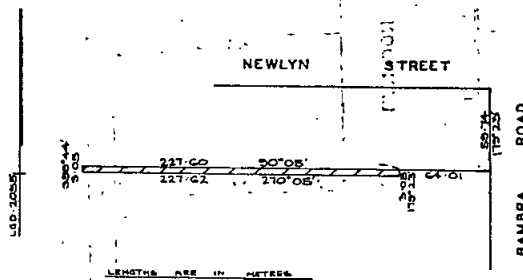

And the Honorable Alan John Hunt, Her Majesty's Minister for Local Government for the State of Victoria, shall give the necessary directions herein accordingly.

TOM FORRISTAL,  
Clerk of the Executive Council.

LOCAL GOVERNMENT DEPARTMENT:

At the Executive Council Chamber, Melbourne, the eighth day of February, 1977.

PRESENT:

His Excellency the Governor of Victoria,  
Mr. Borthwick | Mr. Houghton.

PART OF A ROAD DISCONTINUED.—CITY OF CAULFIELD:

Whereas it is provided in section 528 (2) of the Local Government Act 1958 that where a road (whether or not a public highway but not being a road set out on land of the Crown) or any part thereof is not required for public use the Governor in Council on request of the council of the municipality in which such road is situated made not less than one month after publishing in a newspaper generally circulating in the district and posting to the registered proprietor (if any) of the land and to the owners and occupiers (if any) of the lands abutting or immediately adjacent to the road notice of intention to make such request may by Order published in the Government Gazette direct that such road or part thereof shall be discontinued and thereupon such road or part thereof shall be discontinued accordingly.

And whereas the Council of the City of Caulfield has requested that the Governor in Council direct that part of a road off Dunbar Avenue, Caulfield be discontinued and not less than one month previously has published in a newspaper generally circulating in the district and posted to the registered proprietor of the land in the part of a road and to the owners and occupiers of lands abutting or immediately adjacent to the said part of a road notice of intention to make such request.

Now therefore, His Excellency the Governor of the State of Victoria, by and with the advice of the Executive Council thereof, hereby directs:—

- (a) that the said part of a road which is shown by hachure on the diagram hereunder shall be discontinued;
- (b) that notwithstanding such discontinuance the Melbourne and Metropolitan Board of Works shall continue to have and possess the same right title power authority or interest in or in relation to the whole of the land shown by hachure on the said plan as it had or possessed prior to such discontinuance with respect to or in connection with any drains or pipes laid or erected in on or over such land for the purposes of drainage or sewerage;
- (c) that subject to any such right title power authority or interest, the land in the said part of a road may be sold by the Council of the City of Caulfield by agreement.

CROTONHURST AVENUE

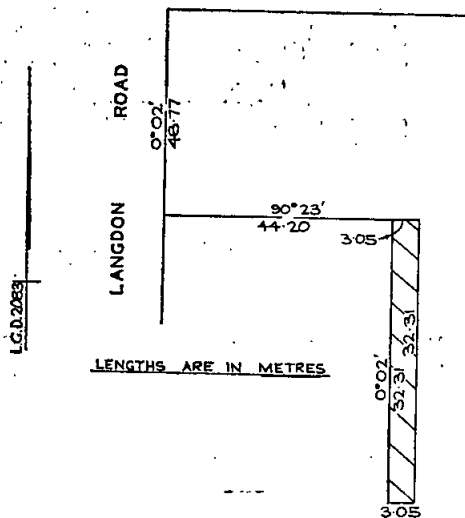

And the Honorable Alan John Hunt, Her Majesty's Minister for Local Government for the State of Victoria, shall give the necessary directions herein accordingly.

TOM FORRISTAL,  
Clerk of the Executive Council.

LOCAL GOVERNMENT DEPARTMENT:

At the Executive Council Chamber, Melbourne, the eighth day of February, 1977.

PRESENT:

His Excellency the Governor of Victoria,  
Mr. Borthwick | Mr. Houghton.

ROAD DISCONTINUED.—CITY OF PRESTON:

Whereas it is provided in section 528 (2) of the Local Government Act 1958, that where a road (whether or not a public highway but not being a road set out on land of the Crown) or any part thereof is not required for public use, the Governor in Council on the request of the council of the municipality in which such road is situated made not less than one month after publishing in a newspaper generally circulating in the district and posting to the registered proprietor (if any) of the land and the owners and occupiers (if any) of lands abutting or immediately adjacent to the road notice of intention to make such request may by Order published in the Government Gazette direct that such road or part thereof shall be discontinued and thereupon such road or part thereof shall be discontinued accordingly.

And whereas the Council of the City of Preston has requested that the Governor-in-Council direct that a road off Croft Crescent, Preston, be discontinued and not less than one month previously has published in a newspaper generally circulating in the district and posted to the registered proprietor of the land in the road and to the owners and occupiers of land abutting or immediately adjacent to the said road notice of intention to make such request.

Now therefore, His Excellency the Governor of the State of Victoria, by and with the advice of the Executive Council thereof, hereby directs:—

- (a) that the said road which is shown by hachure and cross-hachure on the plan hereunder shall be discontinued;
- (b) that notwithstanding such discontinuance the Gas and Fuel Corporation of Victoria shall continue to have and possess the same title power authority or interest in or in relation to the said land shown by cross-hachure as it had or possessed prior to such discontinuance with respect to or in connection with any pipes laid or erected in on or over such land for the purposes of gas supply;
- (c) and, that subject to any such right title power authority or interest, the land in the said road may be sold by the Council of the City of Preston by agreement.

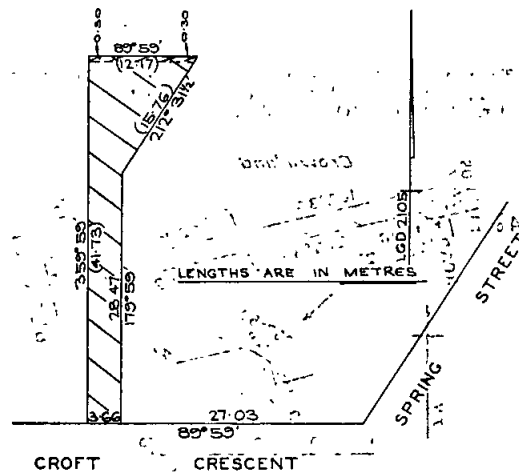

And the Honorable Alan John Hunt, Her Majesty's Minister for Local Government for the State of Victoria, shall give the necessary directions herein accordingly.

TOM FORRISTAL,  
Clerk of the Executive Council.

LOCAL GOVERNMENT DEPARTMENT.

At the Executive Council Chamber, Melbourne, the eighth day of February, 1977.

PRESENT:

His Excellency the Governor of Victoria,  
Mr. Borthwick | Mr. Houghton.

SEVERANCE OF PORTION OF THE SHIRE OF BASS AND ANNEXATION THEREOF TO THE BOROUGH OF WONTHAGGI.

Pursuant to the provisions of Part II. of the Local Government Act 1958; His Excellency the Governor of the State of Victoria, by and with the advice of the Executive Council thereof, and in compliance with an application of the Council of the Borough of Wonthaggi, hereby orders:—

1. That on and from 31st May, 1977, the portion of the municipal district of the Shire of Bass described in the Schedule hereunder shall be severed from the Powlett Riding of the said Shire and annexed to the North Ward of the Borough of Wonthaggi.
2. That the residue of the Powlett Riding of the Shire of Bass shall thenceforth, be deemed to be that subdivision.
3. That all councillors of the North Ward of the Borough of Wonthaggi shall go out of office on the day appointed for the annual election of councillors next after this order takes effect.
4. That this order shall not affect the retirement in accordance with the provisions of Division 2 of Part III. of the said Act of councillors of the South and West Wards of the Borough of Wonthaggi and the Powlett Riding of the Shire of Bass.
5. That for the purpose of any property income assets rights liabilities expenses or matters which may require to be apportioned settled adjusted or determined in consequence of this order, this order shall be deemed to take effect on and from 1st October, 1977.

SCHEDULE.

All that portion of the Shire of Bass commencing at the south-eastern angle of allotment 32, Parish of Wonthaggi; thence northerly, westerly, southerly and north-westerly by the eastern, northern, western and northern boundaries of that allotment and the northern boundary of allotment 25c to the Bass Highway; thence south-easterly by that highway to a road forming the north-western boundary of allotment 25d; thence south-westerly and southerly by that road to the Shire boundary; thence easterly, northerly, south-easterly and easterly by that boundary to the point of commencement.

And the Honorable Alan John Hunt, Her Majesty's Minister for Local Government for the State of Victoria, shall give the necessary directions herein accordingly.

TOM FORRISTAL,  
Clerk of the Executive Council.

COUNTRY ROADS BOARD.

At the Executive Council Chamber, Melbourne, the eighth day of February, 1977.

PRESENT:

His Excellency the Governor of Victoria,  
Mr. Borthwick | Mr. Houghton.

ORDER APPROVING OF LAND BEING ACQUIRED AND ROADS, DEVIATIONS OR WIDENINGS BEING MADE TOGETHER WITH ALL ANCILLARY WORKS REQUIRED TO BE EXECUTED IN CONJUNCTION THEREWITH.

His Excellency the Governor of the State of Victoria, by and with the advice of the Executive Council thereof, being satisfied that there are funds legally available for acquiring the land, doth hereby approve the acquiring of the land described in the schedule hereunder and the

making of new roads and deviations from and widenings of existing roads, together with all ancillary works required to be executed in conjunction therewith, referred to in the said schedule.

SCHEDULE.

Freeway.

The land shown hatched on plans numbered G.P.14353, G.P.14354, G.P.14355, G.P.14356, G.P.14357A, G.P.14358A, G.P.14359A and G.P.14359B hereunder required for the making of a new freeway (Hume Freeway) in the Shire of Seymour.

FREEWAY.

HUME FREEWAY  
SHIRE OF SEYMOUR

Lengths in metres

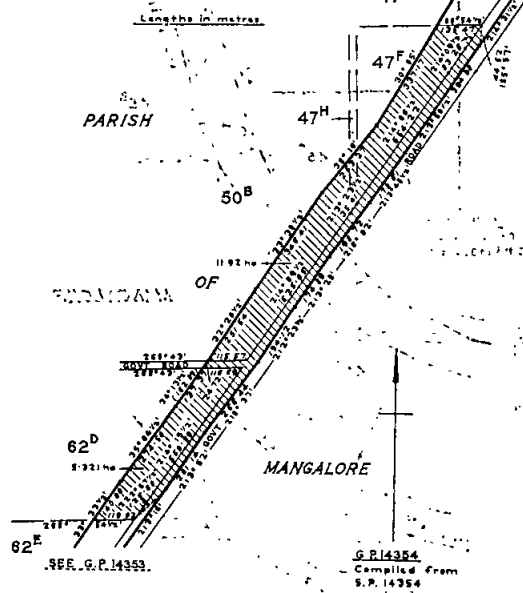
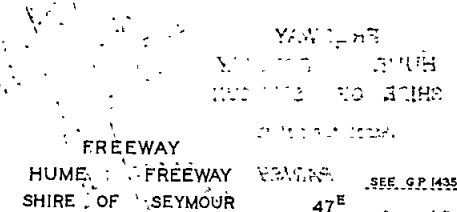
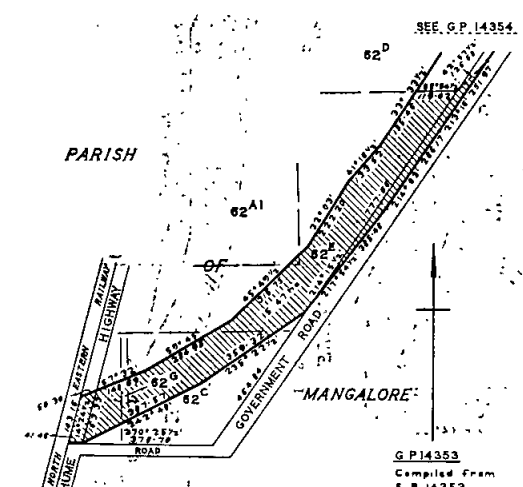

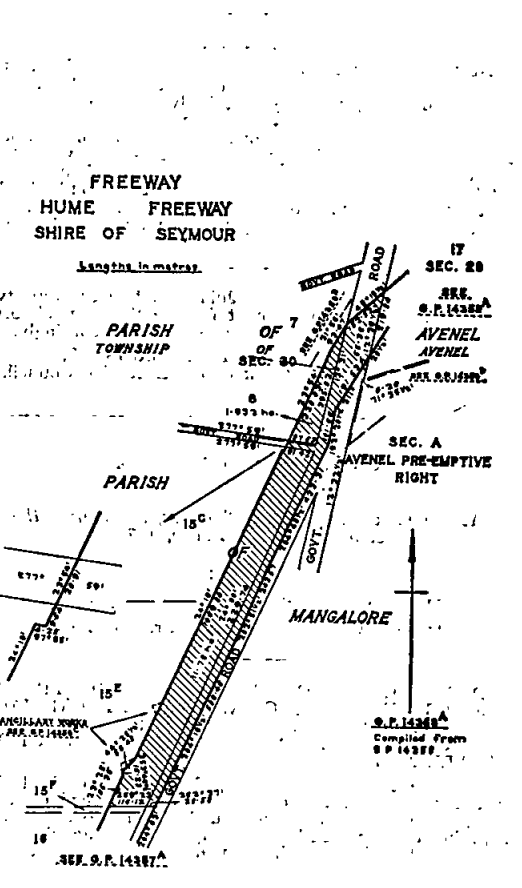
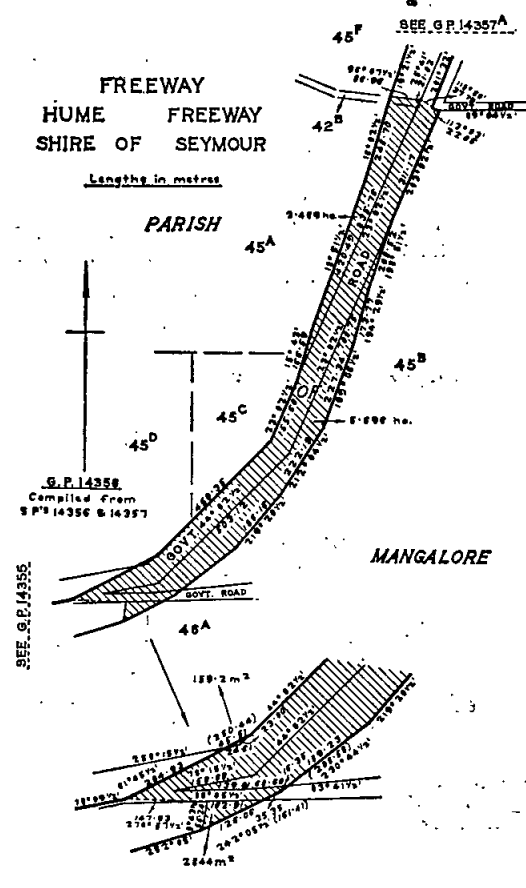
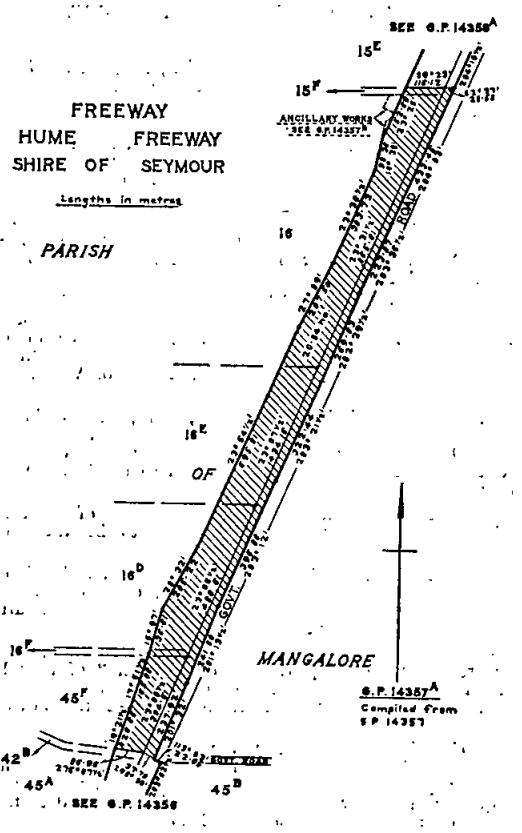
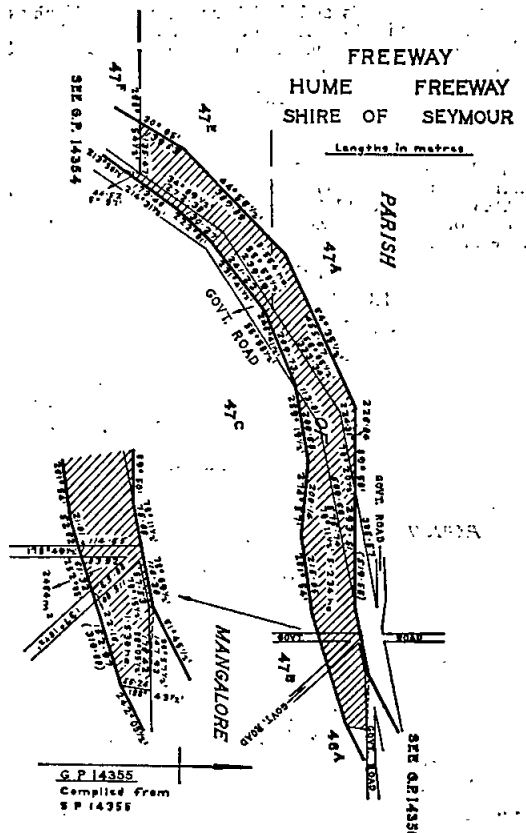

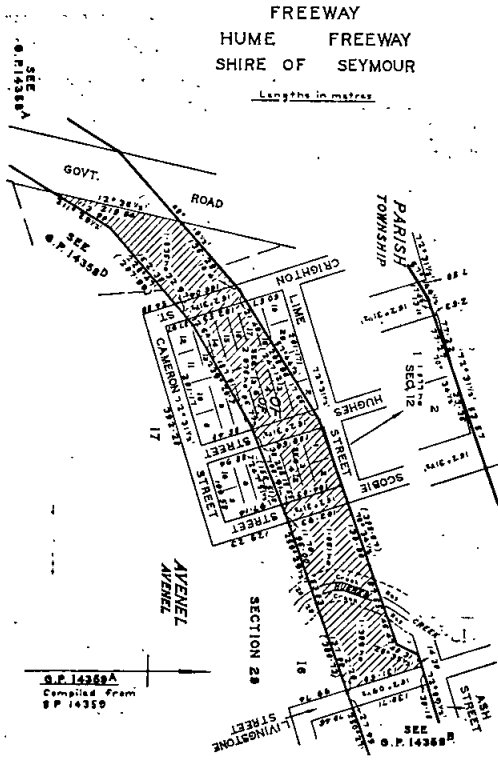

**Unclassified Roads.**  
The land shown hatched on plan numbered G.P.14358b hereunder required for the making of a new road in the Shire of Seymour.

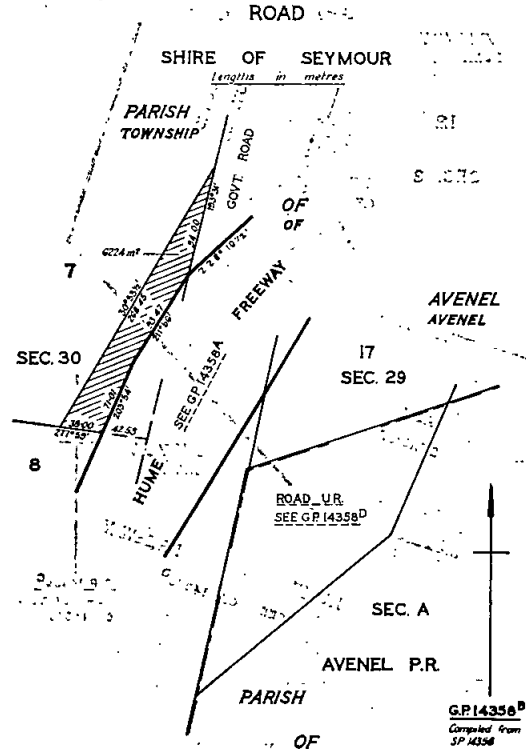

The land shown hatched on plans numbered G.P.14358d and G.P.14359c hereunder required for the widening of a road in the Shire of Seymour and making of the widening thereon.

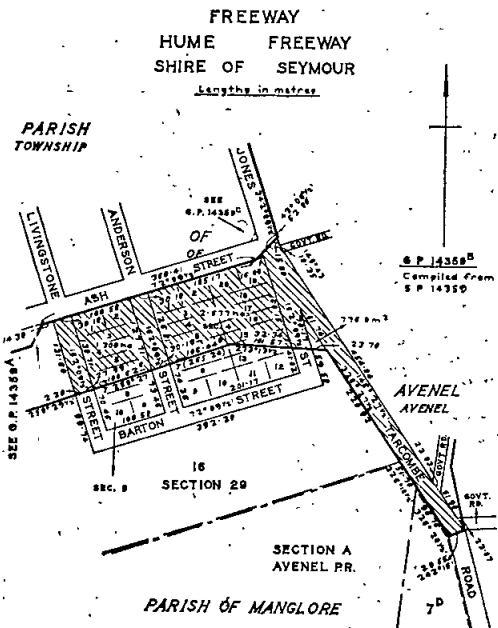
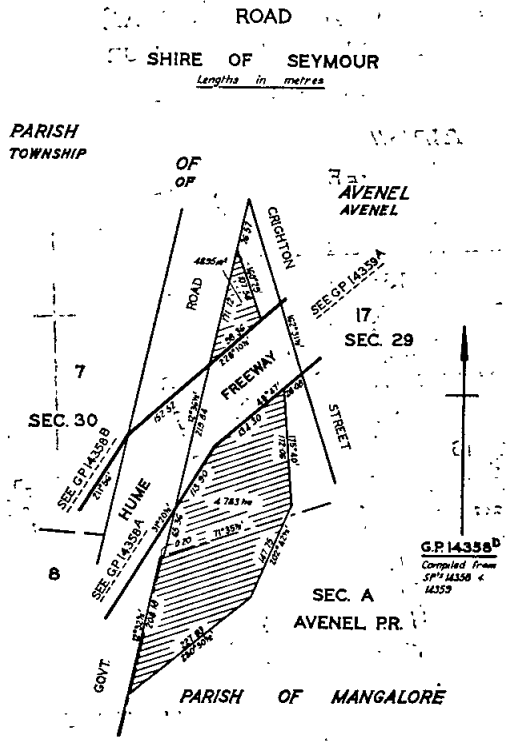

The land shown hatched on plans numbered G.P.14358d and G.P.14359c hereunder required for the widening of a road in the Shire of Seymour and making of the widening thereon.

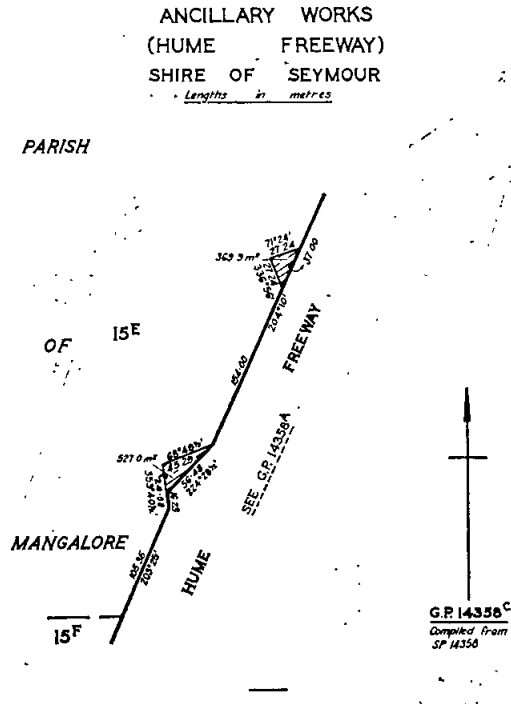
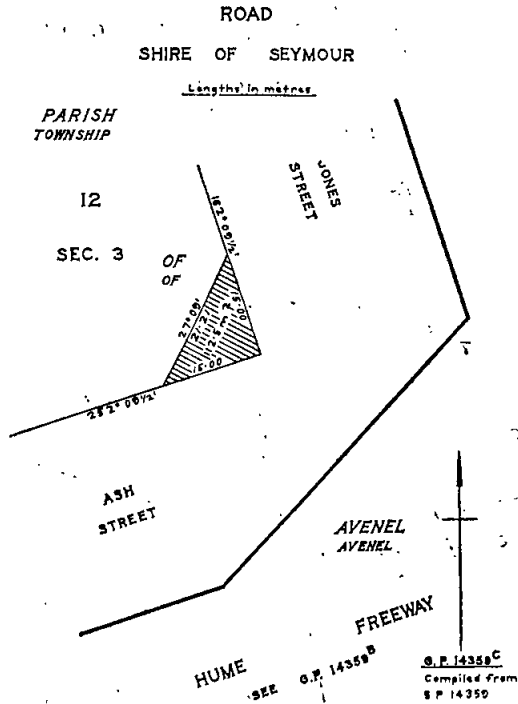

**Ancillary Works.**  
 The land shown hatched on plans numbered G.P.14357b and G.P.14358c hereunder required for ancillary works required to be executed in conjunction with the making of a new freeway in the Shire of Seymour.

And the Honorable Joseph Anstice Rafferty, Her Majesty's Minister of Transport for the State of Victoria, shall give the necessary directions herein accordingly.  
**TOM FORRISTAL,**  
 Clerk of the Executive Council.

**ANCILLARY WORKS  
 (HUME FREEWAY)  
 SHIRE OF SEYMOUR**

**HOSPITALS AND CHARITIES ACT 1958.—SECTIONS  
 46 AND 64.**

*At the Executive Council Chamber, Melbourne, the eighth day of February, 1977.*

PRESENT:

His Excellency the Governor of Victoria.  
 Mr. Borthwick | Mr. Houghton.

**ORDER INCORPORATING BROADMEADOWS  
 COMMUNITY HEALTH CENTRE.**

Whereas a petition signed by not less than twenty-five contributors to the Broadmeadows Community Health Centre a benevolent society capable of incorporation under the *Hospitals and Charities Act 1958*, praying that the benevolent society be incorporated has been received by the Hospitals and Charities Commission:

And whereas the substance or prayer of the said petition has been published in the *Government Gazette* of 15th December, 1976:

And whereas no counter petition signed by an equal or greater number of contributors to the said benevolent society has been lodged with the Hospitals and Charities Commission within one month after the date of publication aforesaid:

Now therefore His Excellency the Governor of the State of Victoria in the Commonwealth of Australia by and with the advice of the Executive Council of the said State doth hereby declare that the contributors for the time being to the said benevolent society shall be a body corporate by the name of the Broadmeadows Community Health Centre with the following objects:

- (a) To manage and maintain a Community Health Service in the Municipality of Broadmeadows which will provide facilities for family physicians, specialists, district nurses, physiotherapists, occupational therapists, social workers, psychiatric nurses and other medical and/or para-medical personnel as are required.

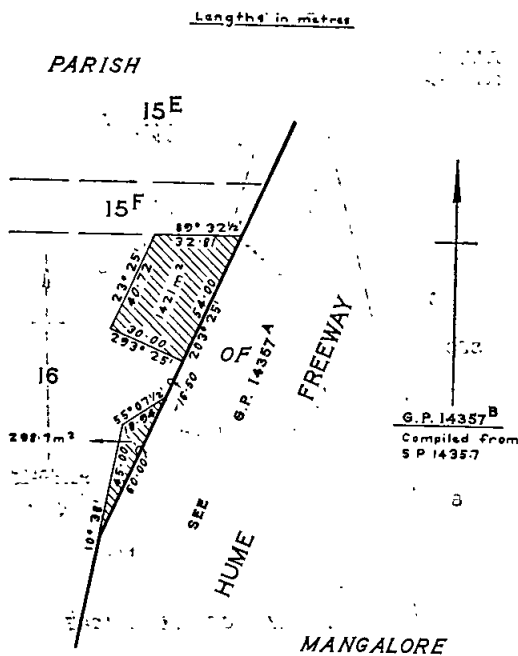



- (b) To provide facilities for diagnosis and treatment of illness and for provision of preventive health services for all persons including those in necessitous circumstances.
- (c) To purchase or acquire any real and/or personal property and other buildings to be used for the above purpose.
- (d) To do all such other things as are incidental or conducive to the attainment of the above objects.

And the Honorable William Vasey Houghton, Her Majesty's Minister of Health for the State of Victoria, shall give the necessary directions herein accordingly.

TOM FORRISTAL,  
Clerk of the Executive Council.

AUDIT ACT 1958.

At the Executive Council Chamber, Melbourne, the eighth day of February, 1977.

PRESENT:

His Excellency the Governor of Victoria.  
Mr. Borthwick | Mr. Houghton.

Pursuant to the provisions of Regulation 3 of the Public Accounts and Stores Regulations 1958 His Excellency the Governor of the State of Victoria, by and with the advice of the Executive Council thereof, doth hereby revoke the Order made on 28th March, 1972, designating certain offices as being offices the occupiers of which shall certify accounts for expenditure under the Division of the Honorable the Attorney-General and in lieu thereof the undermentioned offices are hereby designated as such offices under the said Division:—

DIVISION OF THE HONORABLE THE ATTORNEY-GENERAL.	
Salaries of Chief Justice and Judges	Their Honours the Judges or the Accountant or the Assistant Accountant, Law Department.
Assurance Fund—Claims	The Registrar of Titles or the Chief Examiner of Titles.
Mortgage Moneys—Transfer of Land Act	The Registrar of Titles, the Chief Examiner of Titles or the Senior Executive Advice Officer.
Refunds of Fees Payable in the Office of Titles or the Registrar-General's Office	The Registrar of Titles or an Executive Advice Officer.
Legal Costs—As to charges being reasonable	The Crown Solicitor.
Office of the Public Trustee	Public Trustee, the Accountant, or Assistant Accountant, Office of the Public Trustee, or the Accountant or Assistant Accountant, Law Department.
Discharged Servicemen's Employment Board	The Accountant or the Assistant Accountant, Law Department.
Legal Aid, Act 6805, section 8	
All other expenditure including that from Consolidated Fund and Trust Fund the responsibility of the Division of the Attorney-General not set out above.	
Refunds of Fees payable in the Corporate Affairs Office	The Commissioner for Corporate Affairs or the Executive Officer or the Officer-in-Charge of Administrative Services, Corporate Affairs Office.

And the Honorable Rupert James Hamer, Her Majesty's Treasurer for the State of Victoria, shall give the necessary directions herein accordingly.

TOM FORRISTAL,  
Clerk of the Executive Council.

SMALL CLAIMS TRIBUNALS ACT 1973.

At the Executive Council Chamber, Melbourne, the eighth day of February, 1977.

PRESENT:

His Excellency the Governor of Victoria.  
Mr. Borthwick | Mr. Houghton.

APPOINTMENT OF A REFEREE OF A SMALL CLAIMS TRIBUNAL.

In pursuance of the powers conferred by sections 4, 5, 6 and 7 of the *Small Claims Tribunals Act 1973*, and all other powers him thereunto enabling, His Excellency the Governor of the State of Victoria, by and with the advice of the Executive Council thereof, doth by this Order—

1. appoint GRAEME DOUGLAS JOHNSTONE, a barrister who has not attained the age of 72 years, as a referee of a Small Claims Tribunal for a term of three years commencing on the 1st March, 1977;
2. determine that the remuneration to be paid to him shall be at the rate of \$25,060 a year; and
3. determine that he shall be reimbursed travelling and personal expenses reasonably and necessarily incurred in the performance of his duties at the rate and subject to the conditions prescribed from time to time by the Public Service Determinations for Officers of the Public Service.

And the Honorable Robert Roy Cameron Maclellan, Her Majesty's Minister of Consumer Affairs for the State of Victoria, shall give the necessary directions herein accordingly.

TOM FORRISTAL,  
Clerk of the Executive Council.

SCAFFOLDING ACT 1971.

At the Executive Council Chamber, Melbourne, the eighth day of February, 1977.

PRESENT:

His Excellency the Governor of Victoria.  
Mr. Borthwick | Mr. Houghton.

APPOINTMENT OF MEMBERS OF THE SCAFFOLDING REGULATIONS COMMITTEE.

In pursuance of the powers conferred by section 18 of the *Scaffolding Act 1971*, and all other powers him thereunto enabling, His Excellency the Governor of the State of Victoria, by and with the advice of the Executive Council thereof, doth by this Order appoint—

- Donald Scott Robinson, being a qualified engineer;
  - Neil James Sterling, the Supervisor of Scaffolding Inspection;
  - Edward John Burns, the Chief Inspector of Lifts and Cranes appointed under the *Lifts and Cranes Act 1967*;
  - Keith Gladwyn Hooker, a member of the Building Regulations Committee constituted under the *Local Government Act 1958* and recommended for appointment by that Committee;
  - Donald Cameron McIntosh, from a panel of three names submitted by the executive committee of the Municipal Association of Victoria;
  - John Leslie King, from a panel of three names submitted by the governing body of the Master Builders Association of Victoria;
  - Kevin Francis Casey, from a panel of three names submitted by the Victorian Trades Hall Council; and
  - Kevin George Deacon, from a panel of three names submitted by the governing body of the Australian Institute of Building Surveyors.
- as members of the Scaffolding Regulations Committee for a term of three years.

And the Honorable Robert Roy Cameron Maclellan, Her Majesty's Minister of Labour and Industry for the State of Victoria, shall give the necessary directions herein accordingly.

TOM FORRISTAL,  
Clerk of the Executive Council.

## SUPERANNUATION ACT 1958.

At the Executive Council Chamber, Melbourne, the eighth day of February, 1977.

## PRESENT:

His Excellency the Governor of Victoria.  
Mr. Borthwick | Mr. Houghton.

Pursuant to the powers conferred by the provisions of paragraph (ja) of sub-section (1) of section 3 of the *Superannuation Act 1958*, His Excellency the Governor of the State of Victoria, by and with the advice of the Executive Council thereof doth by this Order declare that the provisions of the *Superannuation Act* shall apply to the officers named in the schedule set out hereunder.

## SCHEDULE.

CRUMP, BARBARA MARY; Ballarat College of Advanced Education.  
SEKHON, ISHER SINGH; Ballarat College of Advanced Education.  
COLMAN, JANINE LORNA; Bendigo College of Advanced Education.  
GEORGE, GEOFFREY RICHARD; Footscray Institute of Technology.  
HARWOOD, PETER KEITH, Gippsland Institute of Advanced Education.

And the Honorable Rupert James Hamer, Her Majesty's Treasurer for the State of Victoria, shall give the necessary directions herein accordingly.

TOM FORRISTAL,  
Clerk of the Executive Council.

## SUPERANNUATION ACT 1958.

At the Executive Council Chamber, Melbourne, the eighth day of February, 1977.

## PRESENT:

His Excellency the Governor of Victoria.  
Mr. Borthwick | Mr. Houghton.

Pursuant to the powers conferred by the provisions of paragraph (ja) of sub-section (1) section 3 of the *Superannuation Act 1958*, His Excellency the Governor of the State of Victoria, by and with the advice of the Executive Council thereof doth by this Order declare that the provisions of the *Superannuation Act* shall apply to GARETH LAURENCE SAMSOM, an officer of The Victorian College of the Arts as from and inclusive of 13th February, 1977.

And the Honorable Rupert James Hamer, Her Majesty's Treasurer for the State of Victoria, shall give the necessary directions herein accordingly.

TOM FORRISTAL,  
Clerk of the Executive Council.

## GORDON TECHNICAL COLLEGE ACT 1976.

At the Executive Council Chamber, Melbourne, the fifteenth day of February, 1977.

## PRESENT:

His Excellency the Governor of Victoria.  
Mr. Hunt | Mr. Smith.  
Mr. Dixon

## CONSTITUTION OF COUNCIL TO MANAGE AND CONTROL THE GORDON TECHNICAL COLLEGE.

Whereas section 4 (2) of the *Gordon Technical College Act 1976* provides that the Governor in Council may on the recommendation of the Minister by Order published in the *Government Gazette* constitute a Council by the name of the Council of the Gordon Technical College as a body corporate to manage and control the Gordon Technical College and exercise the several other powers set out in the said sub-section in relation to the Council so constituted.

Now therefore His Excellency the Governor of the State of Victoria by and with the advice of the Executive Council thereof, and on the recommendation of the Minister, doth by this Order provide as follows:—

## Constitution of Council.

1. There shall be a Council to be known as the "Council of the Gordon Technical College" (hereinafter called "the Council") which shall be a body corporate to manage and control the Gordon Technical College (hereinafter called "the College").

## Membership of Council.

2. (1) The Council shall consist of not more than nineteen members and shall be constituted as follows:—

- (a) the Principal and Deputy Principal of the College shall be members *ex officio*;
- (b) two members shall be members of the full-time teaching staff of the College elected by the full-time teaching staff of the College in a manner determined by the Council;
- (c) one member shall be a member of the full-time non-teaching staff of the College elected by the full-time non-teaching staff of the College in a manner determined by the Council;
- (d) one member shall be appointed by the Minister of Education, being either the Director of Technical Education or a deputy for the Director;
- (e) not more than five members shall be appointed by the Governor in Council to represent commerce, industry and the professions;
- (f) not more than seven members shall be persons associated with or having a special interest in technical education and, in particular, its relationship with commerce, industry and the professions, from time to time appointed by co-option by the Council; and
- (g) one member shall be a member of the student body of the College elected by that body in a manner determined by the Council to hold office until the 31st day of December in the year for which he is elected.

(2) A member of the Council appointed by the Governor in Council may be removed by the Governor in Council.

(3) Members of the Council (other than the Principal, Deputy Principal and Student Member) shall be entitled to hold office for a period of four years from the dates of their respective appointments and elections:

Provided that, in the case only of the first appointments, not more than three of the members appointed pursuant to paragraph (e) of sub-clause (1) and not more than three of the members appointed pursuant to paragraph (f) of sub-clause (1) may be appointed to hold office for two years.

(4) A member of the Council shall be eligible to be re-appointed or re-elected (as the case may be) but no member (other than a member appointed pursuant to paragraph (d) of sub-clause (1)) shall be elected or appointed for more than three successive terms unless he is appointed by co-option for a further term under paragraph (f) of sub-clause (1).

(5) If a member of the Council (other than the Principal or Deputy Principal)—

- (a) resigns his office by writing under his hand directed to the President of the Council;
- (b) becomes of unsound mind or becomes a person whose person or estate is liable to be dealt with in any way under the law relating to mental health;
- (c) becomes bankrupt;
- (d) is convicted of any indictable offence;
- (e) without special leave previously granted by the Council absents himself from four consecutive meetings of the Council;
- (f) ceases to hold any qualification required for his becoming or being a member of the Council;
- (g) being a member appointed by the Governor in Council is removed from office; or
- (h) dies—

his office shall become vacant so as to create a casual vacancy.

(6) A member appointed or elected to fill a casual vacancy shall be entitled to hold office for the unexpired portion of the original term of office only.

(7) Notwithstanding anything to the contrary in sub-clause (1), the Council shall be properly constituted where there is a deficiency in the number of members or members of any class whether originally or as a result of the occurrence of a vacancy.

*Proceedings of Council.*

3. The following provisions shall apply to the Council of the College:—

- (a) the number of members required to constitute a quorum at any meeting of the Council shall be—
- (i) the number being half (or, if half is not a whole number, the next lower whole number) of the number of members then holding office; or
  - (ii) five—  
(whichever is greater);
- (b) the Council shall each year, or where a vacancy occurs during any year, on the occurrence of the vacancy, elect a member to be President of the Council and the President, or in his absence, another member elected to preside, shall preside at any meeting of the Council;
- (c) the Council shall meet at least six times in each year;
- (d) the decision of the majority of those present at any meeting of the Council shall be the decision of the Council;
- (e) in the event of equality of votes on any question, the member presiding shall have a second or casting vote;
- (f) the Council shall provide for the safe custody of the Seal, which shall be used only by authority of the Council, and every instrument to which the Seal is affixed shall be signed by two members of the Council and shall be countersigned by the Secretary (if any) to the Council or by some other person appointed by the Council for that purpose; and
- (g) no member of the Council shall be entitled to vote either in the Council or in a committee of the Council or in a joint committee of members of the Council and of officers of the College on any subject in which he has a direct pecuniary interest.

*Powers of Council.*

4. The Council shall have power to—

- (a) from time to time determine the terms and conditions on which students of the College and any other persons may attend classes or make use of any premises or equipment of the College;
- (b) employ a Principal and Deputy Principal and members of the teaching and the non-teaching staff of the College on such terms and conditions, including rates of remuneration and allowances, as are from time to time determined by the Minister of Education;
- (c) from time to time define the duties of members of the teaching and non-teaching staff of the College;
- (d) suspend or dismiss any member of the teaching or non-teaching staff of the College (but, in the case of dismissal of a member of the teaching staff, only on a resolution of the Council passed by a majority consisting of not less than two-thirds of the total number of members of the Council);
- (e) charge fees approved by the Minister of Education in connection with education provided, examinations held, and other services provided by the College;
- (f) from time to time hold examinations in the several subjects and courses offered by the College and award diplomas, certificates and other awards to students who reach the required standard in any subject or course;
- (g) grant scholarships on such terms and conditions as it thinks fit;
- (h) purchase take on lease or in exchange or hire, and sell mortgage lease or dispose of any real or personal property (which power to sell mortgage lease or dispose of property may, in the case of any real property, be exercised only with the consent of the Minister of Education) and enter into agreements for the supply of services for the College;

- (i) engage architects and other professional advisers, and enter into contracts, for the erection of buildings, the making of improvements or alterations, or the carrying out of repairs, on any land or buildings vested in or occupied or used by the College;
- (j) borrow on overdraft of current account at any bank;
- (k) invest any moneys of the College not immediately required for its purposes in any securities which are authorized investments within the meaning of the law relating to trustees or, with the consent of the Minister of Education, in any other manner;
- (l) accept gifts of real or personal property to the College;
- (m) delegate, subject to such conditions as it thinks fit, any powers vested in the Council to any member or committee of members of the Council, any officer or committee of officers of the College, or any joint committee of members of the Council and officers of the College;
- (n) do all such things as advance the interests of the staff and students of the College;
- (o) do all such things as may be required to be done in order to render the College eligible to receive grants under any law of the Commonwealth of Australia or of the State of Victoria which provides for the making of grants to educational institutions;
- (p) do all such things as are necessarily incidental to the proper management and control of the College or the effective exercise of the powers conferred on the Council.

*Duties of Council.*

5. It shall be the duty of the Council to invite tenders by publishing an advertisement in a newspaper circulating generally throughout the State for the supply of any goods or services or the carrying out of any work the cost of which is estimated by the Council to exceed \$10,000 except in regard to the engagement of architects, consultants and other professional advisers whose charges are normally made at rates fixed and published by professional or statutory bodies.

And the Honorable Lindsay Hamilton Simpson Thompson, Her Majesty's Minister of Education for the State of Victoria, shall give the necessary directions herein accordingly.

TOM FORRISTAL,  
Clerk of the Executive Council.

**DONALD WATERWORKS TRUST.**

At the Executive Council Chamber, Melbourne, the  
fifteenth day of February, 1977.

PRESENT:

His Excellency the Governor of Victoria.  
Mr. Hunt | Mr. Smith.  
Mr. Dixon

**CONSENT TO BORROWING \$100,000.**

Under the powers conferred by the Water Act and all other powers enabling him in that behalf, His Excellency the Governor of the State of Victoria, by and with the advice of the Executive Council of the said State, hereby consents to the Donald Waterworks Trust borrowing the sum of One hundred thousand dollars (\$100,000) to meet the cost of water supply works.

And the Honorable Frederick James Granter, Her Majesty's Minister of Water Supply for the State of Victoria, shall give the necessary directions herein accordingly.

TOM FORRISTAL,  
Clerk of the Executive Council.

PORTLAND WATERWORKS TRUST.

At the Executive Council Chamber, Melbourne, the fifteenth day of February, 1977.

PRESENT:

His Excellency the Governor of Victoria.  
Mr. Hunt | Mr. Smith.  
Mr. Dixon

CONSENT TO BORROWING \$25,000.

Under the powers conferred by the Water Act and all other powers enabling him in that behalf, His Excellency the Governor of the State of Victoria, by and with the advice of the Executive Council of the said State, hereby consents to the Portland Waterworks Trust borrowing the sum of Twenty-five thousand dollars (\$25,000) to meet the cost of water supply works.

And the Honorable Frederick James Granter, Her Majesty's Minister of Water Supply for the State of Victoria, shall give the necessary directions herein accordingly.

TOM FORRISTAL,  
Clerk of the Executive Council.

STAWELL TOWN COUNCIL.

At the Executive Council Chamber, Melbourne, the fifteenth day of February, 1977.

PRESENT:

His Excellency the Governor of Victoria.  
Mr. Hunt | Mr. Smith.  
Mr. Dixon

CONSENT TO BORROWING \$135,000.

Under the powers conferred by the Water Act and all other powers enabling him in that behalf, His Excellency the Governor of the State of Victoria, by and with the advice of the Executive Council of the said State, hereby consents to the Stawell Town Council borrowing the sum of One hundred and thirty-five thousand dollars (\$135,000) in three separate loans of Twenty-five thousand dollars (\$25,000), Forty thousand dollars (\$40,000) and Seventy thousand dollars (\$70,000) to meet the cost of water supply works.

And the Honorable Frederick James Granter, Her Majesty's Minister of Water Supply for the State of Victoria, shall give the necessary directions herein accordingly.

TOM FORRISTAL,  
Clerk of the Executive Council.

CITY OF WARRNAMBOOL.

At the Executive Council Chamber, Melbourne, the fifteenth day of February, 1977.

PRESENT:

His Excellency the Governor of Victoria.  
Mr. Hunt | Mr. Smith.  
Mr. Dixon

CONSENT TO BORROWING \$100,000.

Under the powers conferred by the Water Act and all other powers enabling him in that behalf, His Excellency the Governor of the State of Victoria, by and with the advice of the Executive Council of the said State, hereby consents to the City of Warrnambool borrowing the sum of One hundred thousand dollars to meet the cost of water supply works.

And the Honorable Frederick James Granter, Her Majesty's Minister of Water Supply for the State of Victoria, shall give the necessary directions herein accordingly.

TOM FORRISTAL,  
Clerk of the Executive Council.

COBDEN SEWERAGE AUTHORITY.

At the Executive Council Chamber, Melbourne, the fifteenth day of February, 1977.

PRESENT:

His Excellency the Governor of Victoria.  
Mr. Hunt | Mr. Smith.  
Mr. Dixon

CONSENT TO BORROWING \$100,000.

Under the powers conferred by the Sewerage Districts Act and all other powers enabling him in that behalf, His Excellency the Governor of the State of Victoria, by and with the advice of the Executive Council of the said State, hereby consents to the Cobden Sewerage Authority borrowing the sum of One hundred thousand dollars (\$100,000) to meet the cost of sewerage works as set forth in the detailed statement bearing date 9th February, 1977.

And the Honorable Frederick James Granter, Her Majesty's Minister of Water Supply for the State of Victoria, shall give the necessary directions herein accordingly.

TOM FORRISTAL,  
Clerk of the Executive Council.

SALE CITY COUNCIL.

At the Executive Council Chamber, Melbourne, the fifteenth day of February, 1977.

PRESENT:

His Excellency the Governor of Victoria.  
Mr. Hunt | Mr. Smith.  
Mr. Dixon

CONSENT TO BORROWING \$90,000.

Under the powers conferred by the Water Act and all other powers enabling him in that behalf, His Excellency the Governor of the State of Victoria, by and with the advice of the Executive Council of the said State, hereby consents to the Sale City Council borrowing the sum of Ninety thousand dollars (\$90,000) to meet the cost of water supply works.

And the Honorable Frederick James Granter, Her Majesty's Minister of Water Supply for the State of Victoria, shall give the necessary directions herein accordingly.

TOM FORRISTAL,  
Clerk of the Executive Council.

EDENHOPE SEWERAGE AUTHORITY.

At the Executive Council Chamber, Melbourne, the fifteenth day of February, 1977.

PRESENT:

His Excellency the Governor of Victoria.  
Mr. Hunt | Mr. Smith.  
Mr. Dixon

CONSENT TO BORROWING \$250,000.

Under the powers conferred by the Sewerage Districts Act and all other powers enabling him in that behalf, His Excellency the Governor of the State of Victoria, by and with the advice of the Executive Council of the said State, hereby consents to the Edenhope Sewerage Authority borrowing the sum of Two hundred and fifty thousand dollars to meet the cost of sewerage works as set forth in the detailed statement bearing date 9th February, 1977.

And the Honorable Frederick James Granter, Her Majesty's Minister of Water Supply for the State of Victoria, shall give the necessary directions herein accordingly.

TOM FORRISTAL,  
Clerk of the Executive Council.



Lot 7.

On the north side of Poplar Street being No. 24 Poplar Street.

Upset price \$800.00 the lot. Survey fee \$120.00.  
Area 38 perches (961 square metres). Allotment 45 of section 98.

Lot 8.

On the south side of Poplar Street being No. 1 Poplar Street.

Upset price \$800.00 the lot. Survey fee \$120.00.  
Area 33 perches (835 square metres). Allotment 15 of section 100.

Lot 9.

On the south side of Poplar Street being No. 3 Poplar Street.

Upset price \$800.00 the lot. Survey fee \$120.00.  
Area 33 perches (835 square metres). Allotment 14 of section 100.

Lot 10.

On the south side of Poplar Street being No. 5 Poplar Street.

Upset price \$800.00 the lot. Survey fee \$120.00.  
Area 33 perches (835 square metres). Allotment 13 of section 100.

Lot 11.

On the south side of Poplar Street being No. 7 Poplar Street.

Upset price \$800.00 the lot. Survey fee \$120.00.  
Area 33 perches (835 square metres). Allotment 12 of section 100.

Lot 12.

On the south side of Poplar Street being No. 9 Poplar Street.

Upset price \$800.00 the lot. Survey fee \$120.00.  
Area 35 perches (885 square metres). Allotment 11 of section 100.

Lot 13.

On the south side of Poplar Street being No. 11 Poplar Street.

Upset price \$800.00 the lot. Survey fee \$120.00.  
Area 34 perches (860 square metres). Allotment 10 of section 100.

Lot 14.

On the south side of Poplar Street being No. 13 Poplar Street.

Upset price \$800.00 the lot. Survey fee \$120.00.  
Area 34 perches (860 square metres). Allotment 9 of section 100.

Lot 15.

On the south side of Poplar Street being No. 15 Poplar Street.

Upset price \$800.00 the lot. Survey fee \$120.00.  
Area 34 perches (860 square metres). Allotment 8 of section 100.

Lot 16.

On the south side of Poplar Street being No. 17 Poplar Street.

Upset price \$800.00 the lot. Survey fee \$120.00.  
Area 34 perches (860 square metres). Allotment 7 of section 100.

Lot 17.

On the south side of Poplar Street being No. 19 Poplar Street.

Upset price \$800.00 the lot. Survey fee \$120.00.  
Area 34 perches (860 square metres). Allotment 6 of section 100.

Lot 18.

On the south side of Poplar Street being No. 21 Poplar Street.

Upset price \$2,400.00 the lot. Survey fee \$120.00.  
Area 34 perches (860 square metres). Allotment 5 of section 100.

NOTE.—Prospective purchasers are advised that they will be liable for all charges levied by the respective authorities for the provision of road, footpath, kerb, channel, sewerage and water supply to the land.

PROPOSED PERMANENT RESERVATION OF LAND AS A SITE.

In pursuance of sections 14 and 21 of the Land Act 1958, notice is hereby given that it is the intention of the Governor in Council to reserve permanently from sale, from being leased and from having a licence granted in respect thereof the land hereinafter described:—

The following Notice was published 1<sup>o</sup> on the 19th January, 1977, pursuant to Order of the 11th January, 1977.

MYARING.—Land proposed to be permanently reserved as a site for Public purposes (Conservation of Wildlife), 53.02 hectares, being Crown allotment 37, section B, Parish of Myaring, County of Normanby, as indicated by hatching on plan hereunder.—(M.503<sup>(\*)</sup>) (Rs.10279).

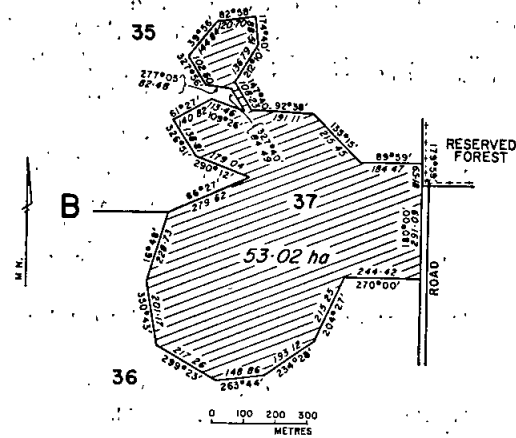

W. BORTHWICK,  
Minister of Lands.

PROPOSED REVOCATIONS OF TEMPORARY RESERVATIONS OF LANDS BY ORDERS IN COUNCIL.

In pursuance of the provisions of the Land Act 1958, notice is hereby given that it is the intention of the Governor in Council to revoke the temporary reservations of lands by Orders in Council hereunder referred to, viz.:—

The following Notices were published 1<sup>o</sup> on the 2nd February, 1977, pursuant to Orders of the 25th January, 1977.

JAMIESON.—The temporary reservation as a site for Recreation purposes and the withholding from sale, leasing and licensing, by Order in Council of the 1st December, 1884, of 2.249 hectares (5 acres 2 roods 9 perches) of land in the Township of Jamieson (Parish of Jamieson in Order), revoked as to part by Order of the 12th January, 1954, are about to be revoked so far only as the portion containing 1070 square metres indicated by hatching on plan hereunder, is concerned.—(J.22<sup>(o)</sup>) (Rs.3460).

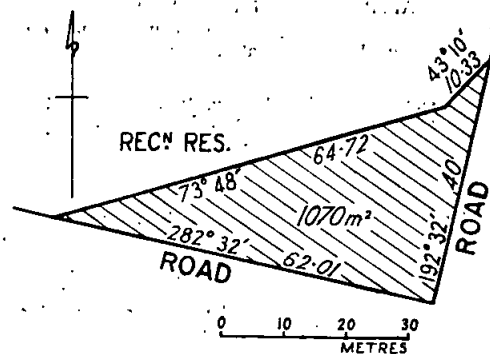

BEAUFORT.—The temporary reservation as a site for Public Recreation, and the withholding from sale, leasing and licensing by Order in Council of the 5th March, 1884, of 11.88 hectares (29 acres 1 rood 15 perches) of

land in the Township of Beaufort are about to be revoked so far only as the portion containing 132 square metres indicated by hatching on plan hereunder is concerned.—(B.304<sup>(6)</sup>) (Rs.843).

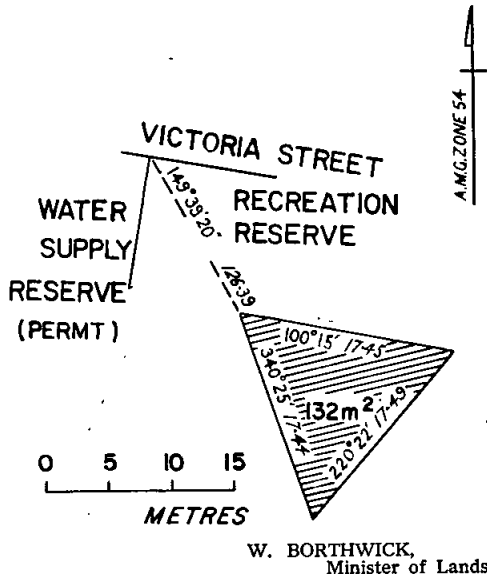

W. BORTHWICK,  
Minister of Lands.

**PROPOSED REVOCATION OF TEMPORARY RESERVATIONS OF LANDS BY ORDERS IN COUNCIL.**

In pursuance of the provisions of the Land Act 1958, notice is hereby given that it is the intention of the Governor in Council to revoke the temporary reservations of lands by Orders in Council hereunder referred to, viz.:—  
The following Notices were published 1° on the 19th January, 1977, pursuant to Orders of the 11th January, 1977.

**CARAPUGNA.**—The temporary reservation by Order in Council of the 17th December, 1888, of 52.13 hectares (128 acres 3 roods 9 perches) of land in the Parish of Carapugna as a site for Water Supply purposes, revoked as to part by Order of the 22nd September, 1908, is about to be revoked so far only as the portion containing 1.144 hectares, indicated by hatching on plan hereunder, is concerned.—(C.439<sup>(4)</sup>) (C.85126).

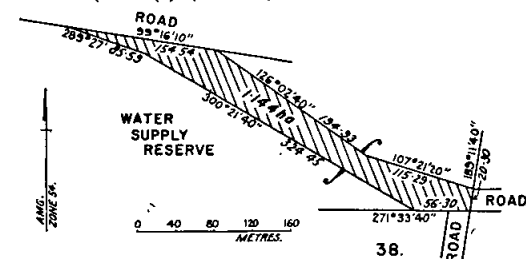

38.

**CLUB TERRACE.**—The temporary reservation by Order in Council of the 7th October, 1958, of 1.184 hectares (2 acres 3 roods 28 perches) of land in the Township of Club Terrace as a site for the purposes of the Forests Act, is about to be revoked.—(C.457<sup>(5)</sup>) (Rs.7623).

**CLUNES.**—The temporary reservation by Order in Council of the 1st August, 1972, of 1012 square metres (1 rood, more or less) of land in the Township of Clunes, as a site for Public purposes (Homes for the Elderly), is about to be revoked.—(C.394<sup>(5)</sup>) (Rs.9640).

**DIAPUR.**—The temporary reservation by Order in Council of the 22nd March, 1887 (see *Government Gazette* 1887, page 846) of 7993 square metres (1 acre 3 roods 36 perches) of land in the Township of Diapur, as a site for a State School, is about to be revoked.—(D.199<sup>(4)</sup>) (Rs.6483).

**DIAPUR.**—The temporary reservation by Order in Council of the 15th December, 1949, of 7664 square metres (1 acre 3 roods 23 perches) of land in the Township of Diapur, as a site for State School purposes, is about to be revoked.—(D.199<sup>(4)</sup>) (Rs.6483).

**SANDHURST (BENDIGO).**—The temporary reservation by Order in Council of the 12th January, 1872 (see *Government Gazette* 1872, page 108) of 1029 square metres (1 rood 7/10 perch) of land at Bendigo, Parish of Sandhurst (called City of Sandhurst in Order) as a site for Police purposes, is about to be revoked so far only as the portion containing 103 square metres indicated by hatching on plan hereunder, is concerned.—(S.372<sup>(110)</sup>) (Rs.10116).

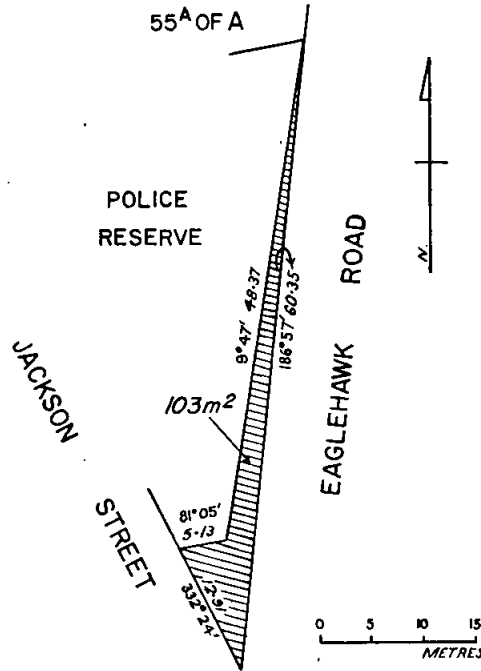

**WONTHAGGI.**—The temporary reservation by Order in Council of the 22nd October, 1912, of 4.487 hectares (11 acres 14 perches) of land in the Township of Wonthaggi (called Borough of Wonthaggi in Order) as a site for Railway purposes, is about to be revoked so far only as the portion containing 6783 square metres indicated by hatching on plan hereunder, is concerned.—(W.345<sup>(17)</sup>) (C.66371).

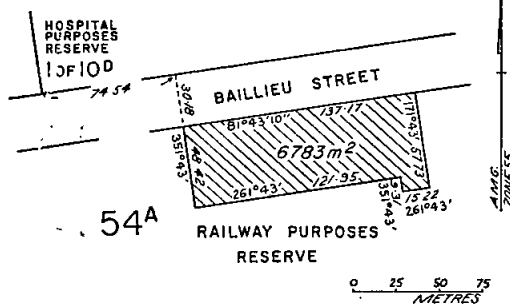

**WONTHAGGI.**—The temporary reservation by Order in Council of the 23rd July, 1918, of 5349 square metres (1 acre 1 rood 11½ perches) of land in the Township of Wonthaggi as a site for Plantation purposes is about to be revoked.—(W.345<sup>(17)</sup>) (Rs.1811).

W. BORTHWICK,  
Minister of Lands.

**PROPOSED PERMANENT RESERVATION OF LAND AS A SITE.**

In pursuance of sections 14 and 21 of the Land Act 1958, notice is hereby given that it is the intention of the Governor in Council to reserve permanently from sale, from being leased and from having a licence granted in respect thereof the land hereinafter described:—

The following Notice was published 1° on the 2nd February, 1977, pursuant to an Order of the 25th January, 1977.

**SHERWOOD (QUAIL ISLAND).**—Land proposed to be permanently reserved as a site for Public purposes (Conservation of Wildlife) also excepted from occupation for

mining purposes under any miner's right, 810 hectares, Parish of Sherwood, County of Mornington, being the site temporarily reserved for Preservation of Native Birds and Animals by Order in Council of the 3rd February, 1960.—(S.271<sup>(a)</sup>) (Rs.7903).

W. BORTHWICK,  
Minister of Lands.

PROPOSED REVOCATIONS OF TEMPORARY RESERVATIONS OF LANDS BY ORDERS IN COUNCIL.

In pursuance of the provisions of the Land Act 1958, notice is hereby given that it is the intention of the Governor, in Council to revoke the temporary reservations of lands by Orders in Council hereunder referred to viz.:—  
The following Notices were published 1<sup>o</sup> on the 9th February, 1977, pursuant to Orders of the 2nd February, 1977.

SANDHURST (Bendigo).—The temporary reservation by Order in Council of the 9th June, 1873 (see Government Gazette 13th June, 1873, page 1056) of 506 square metres (20 perches) of land at Bendigo, Parish of Sandhurst (called City of Sandhurst in Order) as a site for Drainage purposes is about to be revoked.—(S.272<sup>(113)</sup>) (L.6/271).

POWELLTOWN.—The temporary reservation by Order in Council of the 18th May, 1965 of 658 square metres (26 perches) of land in the Township of Powelltown as a site for Public Purposes (purposes of the Forests Department) is about to be revoked.—(P.188<sup>(2)</sup>) (Rs.8444).

POWELLTOWN.—The temporary reservation by Order in Council of the 18th May, 1965 of 1113 square metres (1 rood 4 perches) of land in the Township of Powelltown as a site for Public Purposes (purposes of the Forests Department) is about to be revoked.—(P.188<sup>(2)</sup>) (Rs.8444).

SEYMOUR.—The temporary reservation by Order in Council of the 26th August, 1947, of 1.214 hectares (3 acres) of land in the Township of Seymour as a site for Public Recreation is about to be revoked so far only as the portion containing 4349 square metres indicated by hatching on plan hereunder, is concerned.—(S.261<sup>(3)</sup>) (Rs.4802).

as a site for Public Recreation, revoked as to part by Order of the 16th August, 1937, is about to be revoked so far only as the portion containing 242 square metres indicated by hatching on plan hereunder, is concerned.—(S.261<sup>(3)</sup>) (Rs.4802).

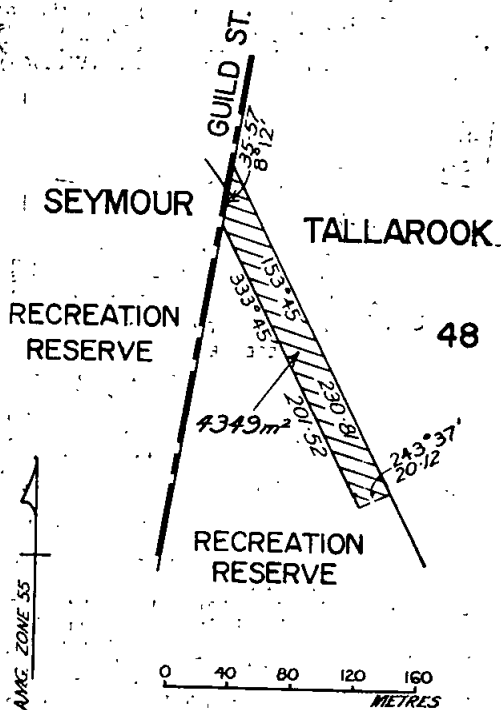
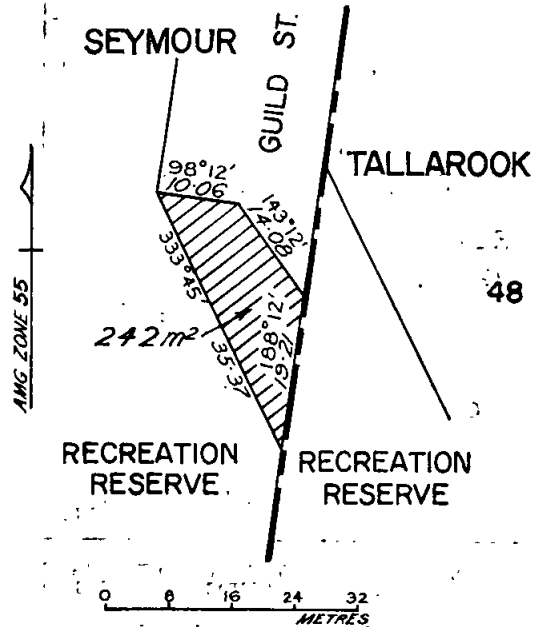

WARNEET.—The temporary reservation by Order in Council of the 28th June, 1960, of 3.642 hectares (9 acres more or less) of land in the Township of Warneet as a site for Public Purposes, is about to be revoked so far only as the portion containing 1660 square metres, more or less, indicated by hatching on plan hereunder, is concerned.—(W.427<sup>(9)</sup>) (Rs.5524).

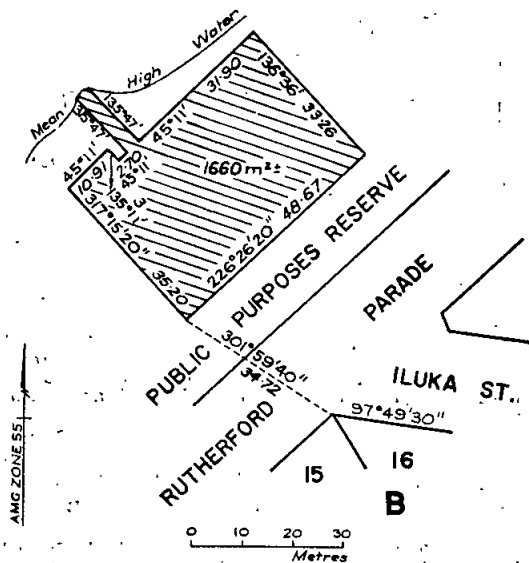

SEYMOUR.—The temporary reservation by Order in Council of the 31st December, 1930, of 4.856 hectares (12 acres more or less) of land in the Township of Seymour

W. BORTHWICK,  
Minister of Lands.



PROPOSED REVOCATIONS OF TEMPORARY  
RESERVATIONS OF LANDS BY ORDERS IN  
COUNCIL.

In pursuance of the provisions of the *Land Act* 1958, notice is hereby given that it is the intention of the Governor in Council to revoke the temporary reservations of lands by Orders in Council hereunder referred to, viz.:—

The following Notices were published 1° on the 16th February, 1974, pursuant to Orders of the 8th February, 1977.

**HEATHCOTE.**—The temporary reservation by Order in Council of the 11th March, 1890, of 2985 square metres (2 roods 38 perches) of land in the Township of Heathcote (called Municipal district of Heathcote in Order) as a site for Railway purposes is about to be revoked.—(H.74(7) (L.6/1072).

**STRATHFIELDSAYE.**—The temporary reservation by Order in Council of the 10th February, 1909, of 2.428 hectares (6 acres) of land in the Township of Strathfieldsaye as a site for Supply of Gravel is about to be revoked.—(S.323(7) (C.39549).

**LEONGATHA.**—The temporary reservation by Order in Council of the 10th March, 1903, of 1.012 hectares (12 acres 2 roods) of land in the Parish of Leongatha as a site for Watering purposes, revoked as to part by Order of the 27th July, 1965, is about to be revoked so far as the balance thereof containing 9788 square metres is concerned.—(L.167(8) (Rs.8174).

W. BORTHWICK,  
Minister of Lands.

REGULATIONS FOR THE CARE, PROTECTION AND  
MANAGEMENT OF CERTAIN LAND IN THE TOWNSHIP  
OF BENALLA RESERVED FOR PUBLIC  
RECREATION.

Whereas by section 218 of the *Land Act* 1958 the Minister of Lands is empowered to make Regulations as to any land which under the provisions of that Act or of any other Act relating to Crown lands has been reserved for any public purpose whatsoever and which has not been conveyed to or vested in trustees: And whereas certain Crown land in the Township and Parish of Benalla was temporarily reserved by Order in Council dated the 11th April, 1972 (*vide* *Government Gazette* of the 19th April, 1972) as a site for Public Recreation Purposes: And whereas such land (hereinafter called the "Reserve") has not been conveyed to or vested in trustees: And whereas it is expedient that Regulations for the care, protection and management of the Reserve and for other purposes connected therewith should be made: Now therefore I, William Archibald Borthwick, Her Majesty's Minister of Lands in and for the State of Victoria, in pursuance of the powers aforesaid, do hereby make the following Regulations for or with respect to the Reserve:—

REGULATIONS.

1. In these Regulations, unless inconsistent with the context or subject matter—

"Committee" means the Committee of Management appointed pursuant to the provisions of section 221 of the *Land Act* 1958 in respect of the Reserve.

"Vehicle" includes every conveyance capable of being propelled, pushed or drawn by human, animal, mechanical, electrical or other power and includes a motor car as defined in the *Motor Car Act* 1958, but expressly excludes perambulators.

2. The Reserve shall be open to the public at all times free of charge, except on such occasions as the Reserve or any portion thereof may be set apart for football, cricket, basket-ball, tennis or other games, fêtes, sports or amusements, on any of which occasions a sum not exceeding \$2.00 may be charged and taken for the admission of any person to the Reserve.

3. The Committee may set apart any portion or portions of the Reserve for the purposes of football, cricket, tennis, basket-ball or other games, fêtes, sports or amusements, or as a pleasure ground or place of public resort or recreation.

4. No person shall without the permission, in writing, of the Committee first obtained, at any time play or practise at football, cricket, tennis, basketball or other forms of amusement in the Reserve, and such permission may be granted upon such terms and conditions as the Committee may deem to be reasonable and consistent with these Regulations; provided, however, that the Committee shall not arbitrarily refuse to grant permission for the use of the Reserve for public recreation purposes.

5. No person shall cross or trespass on any area set aside as hereinbefore provided during any cricket or football match, basketball, game, sport or amusement or during practice at football, cricket, basketball or any game, sport or amusement when such crossing or trespassing would be injurious or be an undue interference to the progress of such football or cricket match, basketball, game, sport or amusement.

6. No person shall climb, jump or get upon or over or under any of the fences or gates in or around the Reserve, or cut or damage or in any way remove any of such fences or gates or any buildings, seats, equipment, trees, shrubs or flowers therein, nor shall any person affix bills or advertisements or writings on any of such fences, gates, buildings, seats, equipment or trees without the consent, in writing, of the Committee.

7. No person shall light a fire in the Reserve, or dig or remove any turf or soil or enter any plot enclosed for a plantation of young trees or shrubs or walk on or over any flower bed therein or commit any nuisance or damage or destroy any property or thing in the Reserve.

8. No person shall throw, deposit or leave any glass, filth, rubbish, refuse, junk or waste material of any kind in the Reserve or cause any glass, filth, rubbish, refuse, junk or waste material of any kind to be thrown or deposited upon or left in the Reserve or in or upon any building or structure therein.

9. Any person using the Reserve or any building or structure therein for any purpose consistent with the purposes of the reservation shall, prior to leaving such Reserve, building or structure, collect and remove or cause to be collected and removed all waste material, scraps, bottles, glass or litter of any kind brought into or made by such person in the Reserve, and any person who fails or refuses to collect and remove or cause to be collected and removed all waste material, scraps, bottles, glass or litter of any kind brought into or made by such person shall pay to the Committee the cost of removing same and such cost may be recovered by the Committee before a Court of Petty Sessions.

10. No person shall carry or discharge any firearm in the Reserve, or snare, trap, catch or destroy or interfere in any way with any birds therein, or throw or discharge any stone or other missile in the Reserve.

11. No person shall enter or remain in the Reserve in a state of intoxication, and no person shall bring or cause to be brought any intoxicating liquor into or upon the Reserve for the purpose of consumption without the written consent of the Committee.

12. No person shall behave in a noisy or disorderly manner or create or take part in any disturbance or commit any act of indecency or offend against decency as regards dress, language or conduct in the Reserve or in any building or structure therein.

13. No person shall sell or offer for sale in the Reserve any article of food or drink or any other commodity, or operate any amusement for which a charge is made or erect any tent, booth, stand, building or other structure in the Reserve without the permission, in writing, of the Committee.

14. No person shall make any wager for money or play any unlawful game in the Reserve.

15. No person shall wilfully obstruct, disturb, interrupt or annoy any other person in the proper use of the Reserve, or wilfully obstruct, disturb, interrupt or annoy any employee of the Committee or member of the Police Force in the proper execution of his duty or work in the Reserve.

16. No person or organisation shall assemble in the Reserve for picnics, or for the purpose of public worship, preaching or public speaking of any kind or meetings of a like character without the permission, in writing, of the Committee.

17. No person shall camp or park a caravan or motor car in the Reserve without the consent, in writing, of the Committee.

18. No person shall give out or distribute any handbill, placard, notice, advertisement, book, pamphlet or paper in the Reserve without the consent, in writing, of the Committee or litter the Reserve by scattering or throwing down any such handbill, placard, notice, advertisement, book, pamphlet or paper.

19. No person shall ride, drive or lead or cause to be ridden, driven or led any horse on, over or through the Reserve without the permission, in writing, of the Committee.

20. No person shall bring into the Reserve any dog unless controlled by a leash or cord.

21. (a) No person shall, except as hereinbefore provided, bring into, cause or permit any cattle, sheep or other animals to enter or remain in the Reserve and the Committee shall have full power and authority to impound any such cattle, sheep or other animals found therein.

(b) The owner of any cattle, sheep or other animals that are found in the Reserve as provided in this Regulation shall be guilty of an offence against these Regulations.

22. No person shall drive a vehicle in, over or through the Reserve, except any vehicle used by any employee of the Committee in the execution of his duties, or by any person having obtained the consent of the Committee, in writing, to play or practise football, cricket, tennis, basketball or any other game or sport or to conduct any fête or amusement, using a vehicle in connection therewith.

In this Regulation "drive" means to drive, propel, push or draw a vehicle.

23. No person shall remove, displace or disfigure any board, plate or tablet or any support, fastening or fitting used or constructed for the exhibition of any Regulation or notice fixed or set up by the Committee in the Reserve.

24. The Committee shall have the power and authority to restrict the use of any swing, wheel, fitting, fixture, slide or appliance erected, placed or provided in the Reserve to certain persons by means of a notice posted in the vicinity (which notice shall indicate which person or persons are permitted to use same) and no person or persons other than those indicated on the said notice shall use or interfere with any such swing, wheel, fitting, fixture, slide or appliance.

25. The Committee shall have the power and authority to close the Reserve or any part thereof and exclude the public therefrom whenever the Committee considers it necessary to carry out repairs, alterations or reconditioning of turf or for any other purpose having as its object the proper care and management of the Reserve.

26. No person shall spit or expectorate in or on the Reserve or in or on any building or structure therein.

27. Any person offending against any of the Regulations may, in addition to any other penalty to which he may be liable, be removed from the Reserve by a member of the Police Force or any employee of the Committee, and any person so removed shall not again enter the Reserve during the day he is so removed.

28. No person shall aid, abet, counsel or procure any other person in doing any act or thing which is a breach of these Regulations.—(Rs9602).

Given under my hand, at Melbourne, on the 9th day of February, 1977.

W. A. BORTHWICK,  
Minister of Lands.

Every person who contravenes or fails to comply with these Regulations shall, in accordance with the provisions of section 218 of the *Land Act 1958*, for each offence be liable to a penalty of not more than Fifty dollars, and every person who contravenes or fails to comply with any such Regulations, and who, after he has been warned by any bailiff of Crown lands or by any member of the Police Force, does not desist therefrom may be forthwith apprehended by such bailiff or member of the Police Force and taken before some justice to be dealt with according to law and shall be liable to a penalty of not more than One hundred dollars, provided that every person who contravenes any Regulation made under the said section for or with respect to prohibiting the depositing and leaving of any unwanted material or thing or rubbish of any kind on any land to which such Regulation relates shall for each offence be liable to a penalty of not more than Two hundred dollars.

REGULATIONS FOR THE CARE, PROTECTION AND MANAGEMENT OF "GLENALADALE NATIONAL PARK".

Whereas by section 218 of the *Land Act 1958* the Minister of Lands is empowered to make Regulations as to any land which under the provisions of that Act or of any other Act relating to Crown lands has been reserved for any public purpose whatsoever and which has not been conveyed to or vested in trustees: And whereas certain Crown lands in the Parish of Glenaladale were reserved for various Public Purposes as stipulated in the Schedule hereunder: And whereas such lands (hereinafter called the "Reserve") have not been conveyed to or vested in trustees but have been placed under the control of a Committee of Management pursuant to section 221 of the

*Land Act 1958*: And whereas it is expedient that Regulations for the care, protection and management of the Reserve and for other purposes connected therewith should be made: Now therefore I, William Archibald Borthwick, Her Majesty's Minister of Lands in and for the State of Victoria, in pursuance of the powers aforesaid, do hereby make the following Regulations for or with respect to the Reserve:—

SCHEDULE.

- (a) The land in the Parish of Glenaladale temporarily reserved as a site for Public Purposes (National Park) by Order in Council dated the 20th July, 1976 (*vide Government Gazette* of the 28th July, 1976).
- (b) That portion of the land in the said Parish temporarily reserved as a site for Public Purposes by Order in Council dated the 24th January, 1938 (*vide Government Gazette* on the 26th January, 1938), as is indicated by green colour on plan marked "G". 15/7/75" attached to Lands Department correspondence No. Rs.8251.
- (c) That portion of the land in the said Parish permanently reserved as a site for Public Purposes by Order in Council dated the 23rd May, 1881 (*vide Government Gazette* of the 27th May, 1881), as is indicated by blue colour on the abovementioned plan.

REGULATIONS.

(1) The Director of National Parks or his authorized officers are empowered to have carried out such works and improvements considered necessary for the management of the Reserve and for the control of the public therein.

(2) Without the consent, in writing, of the Director of National Parks or his authorized officers, no person shall—

- (a) Camp within the Reserve or light or maintain any fire therein.
- (b) Deposit any rubbish, debris or material of any kind within the Reserve.
- (c) Interfere with or remove or damage or destroy any tracks, signs, buildings or any improvements or structures in the Reserve.
- (d) Deposit on or construct within the Reserve any fence, shed, structure or equipment. Any fence, shed, structure or other equipment located within the Reserve without permission will be dismantled and removed from the Reserve.
- (e) Carry a firearm of any description or any weapon or instrument capable of discharging a missile, or shoot at or kill or injure any animal, bird or other wildlife in the Reserve.
- (f) Carry any poison, traps or snares in the Reserve.
- (g) In the Reserve poison, trap, snare, catch or otherwise destroy, interfere with or disturb any bird or other animal, or have in his or her possession any skin, egg, feather or nest or part thereof which have been found in or removed from the Reserve.
- (h) Bring or allow any animal of any kind into the Reserve. Any dog shall be liable to be destroyed. Any "catle" as defined by section 3 of the *Pounds Act 1958*, found trespassing within the Reserve shall be liable to be impounded.
- (i) In the Reserve pluck, cut, dig, pick up, damage or otherwise interfere with or have in his or her possession the whole or any part of any shrubs, flowers, grasses, trees or plants of any kind which have been found in or removed from the Reserve.
- (j) Dig or remove any sand, soil or other material in or from the Reserve.
- (k) Drive any vehicle on the Reserve other than on a road or roads provided for the purpose.—(Rs.8251).

Given under my hand at Melbourne on the ninth day of February, 1977.

W. BORTHWICK,  
Minister of Lands.

Every person who contravenes or fails to comply with these Regulations shall, in accordance with the provisions of section 218 of the *Land Act 1958*, for each offence be liable to a penalty of not more than Fifty dollars, and

every person who contravenes or fails to comply with any such Regulations, and who, after he has been warned by any bailiff of Crown Lands or by any member of the Police Force, does not desist therefrom may be forthwith apprehended by such bailiff or member of the Police Force and taken before some justice to be dealt with according to law and shall be liable to a penalty of not more than One hundred dollars, provided that every person who contravenes any Regulation made under the said section for or with respect to prohibiting the depositing and leaving of any unwanted materials or thing or rubbish of any kind on any land to which such Regulation relates shall for each offence be liable to a penalty of not more than Two hundred dollars.

**COMMON ABOUT TO BE DIMINISHED.**

In pursuance of the provisions contained in the Land Act 1958, notice is hereby given that it is the intention of the Governor in Council to diminish the common herein-after mentioned, viz.:—

The following Notice was published 1° on the 2nd February, 1977, pursuant to an Order of the 25th January, 1977.

The Ballarat West Town Common, proclaimed as such by the Governor in Council on the 28th January, 1861 (see Government Gazette, 6th February, 1861, page 256), is about to be diminished by the excision therefrom of the portion in the Parish of Dowling Forest containing 9104 square metres, indicated by hatching on plan hereunder.—(C.91998.)

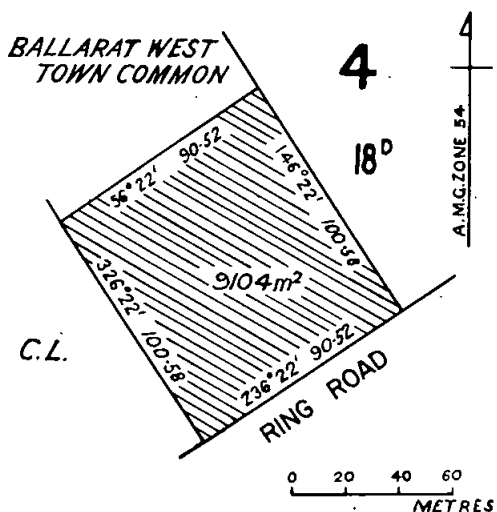

W. BORTHWICK,  
Minister of Lands.

**TENDERS**

**PUBLIC WORKS DEPARTMENT**

Tenders will be received at Public Works Department, 2 Treasury Place, Melbourne, until TWO p.m. on dates shown for purposes mentioned hereunder.

Particulars and tender forms available at Contracts Office, Room 27, Ground Floor, No. 2, Treasury Place, and at Inspector of Works Office if indicated by W.O. Tenders must be on a "Firm Tender" basis. The lowest or any tender will not necessarily be accepted.

Address tenders to the Minister of Public Works, and endorse the envelope "Tender for...". Hand delivered tenders to be placed in the Tender Box of the Public Works Department, Main Entrance Foyer, Ground Floor, 2 Treasury Place, Melbourne.

No preliminary deposit is required with any tender, but successful tenderer will be required to pay a deposit for any accepted tender of \$10,000 or over.

**Tuesday, 1st March, 1977.**

**Building, Electrical and Mechanical Works.**

BENALLA EAST.—Exterior renovations, Primary School 2256. (W.O., Wangaratta and Benalla.)

BRIGHTON.—Replacement of staircase and allied works, Technical School.

ECHUCA.—External and internal painting, Primary School No. 208. (W.O., Bendigo.)

GIRGARRE.—Internal and external renovations, Primary School 3971. (W.O., Bendigo.)

OAKLEIGH EAST.—Installation of thermal fire protection system, Primary School 4327.

SILVAN.—Internal and external repairs and painting, Primary School 1801.

SOUTH YARRA.—Repairs and painting to steel framed windows, including glazing and painting to the east elevation, High School.

UPWEY.—Internal and external repairs and painting, Primary School 4530.

WANGARATTA.—Supply and installation—"goods hoist", Technical College. (W.O., Wangaratta.)

WODONGA WEST.—Electrical services—art/craft room, Primary School 4814. (W.O., Wangaratta.)

WODONGA WEST.—Mechanical services—art/craft room, Primary School 4814. (W.O., Wangaratta.)

**Site Works.**

HEIDELBERG.—Site works, High School.

**Miscellaneous.**

MERBEIN.—Connection to town sewerage, High School. (W.O., Mildura.)

PORT MELBOURNE.—Supply of 24,000 plastic containers, storeyard.

PORT MELBOURNE.—Supply of 2,000 mobile storage trolleys, storeyard.

PORT MELBOURNE.—Supply of 1 x 2 ton capacity double cabin utility, depot.

PORT MELBOURNE.—Supply of 1 x 2 ton capacity double cabin utility with canopy, depot.

**Tuesday, 8th March, 1977.**

**Building, Electrical and Mechanical Works.**

ALLANSFORD.—Internal and external painting, Primary School No. 3 (W.O., Warrnambool.)

BELL POST HILL.—Internal and external repairs and renovations, Primary School No. 4804. (W.O., Geelong.)

BELGRAVE SOUTH.—Internal and external repairs and painting, Primary School No. 3551.

BONBEACH.—Internal and external repairs and painting, High School.

CAMPERDOWN.—External and internal repairs and painting, Primary School No. 114. (W.O., Camperdown.)

ECHUCA.—External renovations, High School. (W.O., Bendigo.)

MELBOURNE.—Renovations to annexe at 497-499 La Trobe Street, Melbourne, College of Hairdressing.

MT. BUFFALO.—Erection of singlemens' quarters and caravan port for three caravans, National Park. (W.O., Benalla and Wangaratta.)

VIEWBANK.—Supply and installation of "Book Lift", Primary School No. 4892.

**Miscellaneous.**

HAWKESDALE.—Re-advertised. Construction of sewage treatment plant, High School. (W.O., Warrnambool.)

HEYWOOD.—Connection to town sewer, High School. (W.O., Warrnambool.)

ROBERTS DUNSTAN,  
Minister for Public Works.

Public Works Department,  
Melbourne, 15th February, 1977.

*Teaching Service Act 1958.*

TEACHING SERVICE (TEACHERS TRIBUNAL)  
REGULATIONS.

AMENDMENT No. 409 (T.T.43).

The Teachers Tribunal, in pursuance of the powers conferred by the *Teaching Service Act 1958*, hereby amends Regulation 4 of the Teaching Service (Teachers Tribunal) Regulations as follows:—

REGULATION 4.

Rescind the second proviso to sub-clause 3 (a) and substitute therefor the following proviso:—

“Provided further that members appointed as Relieving Principals or as Regional Relieving Assistants in the Secondary Schools Division or the Technical Schools Division shall be eligible to transfer after a period of one year.”

W. E. SAMPSON, Chairman.

A. F. LE CLERCQ, Secretary.

Office of the Teachers Tribunal,  
Melbourne, 9th February, 1977.

*Teaching Service Act 1958.*

TEACHING SERVICE (TEACHERS TRIBUNAL)  
REGULATIONS.

AMENDMENT No. 408 (T.T.42).

The Teachers Tribunal, in pursuance of the powers conferred by the *Teaching Service Act 1958*, hereby amends Regulation 3 of the Teaching Service (Teachers Tribunal) Regulations as follows:—

REGULATION 3.

1. In paragraph (ii) of sub-clause 13 (a) for the words “below all teachers previously promoted to the class.” substitute the words “below all teachers promoted to the class in the year those the Committee deems to be contemporaries were promoted to that class.”

2. In paragraph (ii) of sub-clause 13 (a) rescind the sentence which reads “In determining the relative seniority of such applicant in relation to that of other teachers promoted to the class at the same meeting, consideration shall be given by the Committee of Classifiers to the relative order of seniority he occupied with regard to contemporaries before his appointment to a professional position.”

W. E. SAMPSON, Chairman.

A. F. LE CLERCQ, Secretary.

Office of the Teachers Tribunal,  
Melbourne, 9th February, 1977.

*Teaching Service Act 1958.*

TEACHING SERVICE—TECHNICAL SCHOOLS DIVISION  
(CLASSIFICATION, SALARIES, AND ALLOWANCES)  
REGULATION.

AMENDMENT No. 407 (TECH. C.S. & A.11).

The Teachers Tribunal, in pursuance of the powers conferred by the *Teaching Service Act 1958*, hereby amends the Teaching Service—Technical Schools Division (Classification, Salaries, and Allowances) Regulation as follows:—

In sub-clause 12 (a) for the expression “two weeks” substitute the expression “one week”.

W. E. SAMPSON, Chairman.

A. F. LE CLERCQ, Secretary.

Office of the Teachers Tribunal,  
Melbourne, 8th February, 1977.

*Teaching Service Act 1958.*

TEACHING SERVICE—PRIMARY SCHOOLS DIVISION  
(CLASSIFICATION, SALARIES, AND ALLOWANCES)  
REGULATION.

AMENDMENT No. 405 (PRIM. C.S. & A.9).

The Teachers Tribunal, in pursuance of the powers conferred by the *Teaching Service Act 1958*, hereby amends the Teaching Service—Primary Schools Division (Classification, Salaries, and Allowances) Regulation as follows:—

In sub-clause 12 (a) for the expression "two weeks" substitute the expression "one week".

W. E. SAMPSON, Chairman.  
A. F. LE CLERCQ, Secretary.

Office of the Teachers Tribunal,  
Melbourne, 8th February, 1977.

*Teaching Service Act 1958.*

TEACHING SERVICE—PROFESSIONAL (CLASSIFICATION,  
SALARIES, AND ALLOWANCES) REGULATION.

AMENDMENT No. 404 (PROF. C.S. & A.11).

The Teachers Tribunal, in pursuance of the powers conferred by the *Teaching Service Act 1958*, hereby amends the Teaching Service—Professional (Classification, Salaries, and Allowances) Regulation as follows:—

In sub-clause 6 (a) for the expression "two weeks" substitute the expression "one week".

W. E. SAMPSON, Chairman.  
A. F. LE CLERCQ, Secretary.

Office of the Teachers Tribunal,  
Melbourne, 8th February, 1977.

*Teaching Service Act 1958.*

TEACHING SERVICE—PROFESSIONAL (CLASSIFICATION,  
SALARIES, AND ALLOWANCES) REGULATION.

AMENDMENT No. 403 (PROF. C.S. & A.10.)

The Teachers Tribunal, in pursuance of the powers conferred by the *Teaching Service Act 1958*, hereby amends the Teaching Service—Professional (Classification, Salaries, and Allowances) Regulation as follows:—

1. In clause 4 for the expression "clauses 7 and 8" substitute the expression "clauses 7, 8, 9, and 10".

2. After clause 9 insert the following clause:—

"10. *Demonstration Units.*

The following shall be the rates of salary paid to professional officers occupying positions in Demonstration Units:—

Designation.	Salary Range.		
	\$	\$	\$
Officer in Charge—Demonstration Unit	16,893;	17,405	
Deputy Officer in Charge—Demonstration Unit	15,620;	16,256	
Demonstration Unit Officer	11,951;	12,454;	12,957;
	13,609;	14,260;	14,880;
	15,620.		

Provided that Demonstration Unit Officers possessing less than an aggregate of four years' training shall not proceed beyond a salary of \$14,880."

(To take effect from and including the 1st March, 1977.)

W. E. SAMPSON, Chairman.  
A. F. LE CLERCQ, Secretary.

Office of the Teachers Tribunal,  
Melbourne, 14th February, 1977.

## Teaching Service Act 1958.

TEACHING SERVICE—SECONDARY SCHOOLS DIVISION  
(CLASSIFICATION, SALARIES, AND ALLOWANCES)  
REGULATION.

## AMENDMENT No. 406 (SEC. C.S. &amp; A.10).

The Teachers Tribunal, in pursuance of the powers conferred by the *Teaching Service Act 1958*, hereby amends the *Teaching Service—Secondary Schools Division (Classification, Salaries, and Allowances) Regulation* as follows:—

In sub-clause 12 (a) for the expression "two weeks" substitute the expression "one week".

W. E. SAMPSON, Chairman.  
A. F. LE CLERCQ, Secretary.

Office of the Teachers Tribunal,  
Melbourne, 8th February, 1977.

## PRIVATE ADVERTISEMENTS

Town and Country Planning Act 1961 (Twelfth Schedule).  
CITY OF BENALLA PLANNING SCHEME.

NOTICE THAT A PLANNING SCHEME HAS BEEN PREPARED  
AND IS AVAILABLE FOR INSPECTION.

## Amendment No. 13.

Notice is hereby given that the City of Benalla in pursuance of its powers under the *Town and Country Planning Act 1961* has prepared a Planning Scheme for:—

Rezoning Lot 1, Part Crown allotment 1, section 1b, L.P.53943, South East corner of Benson and Market Street, Benalla, from Proposed Public Open Space to Residential C.

A copy of the scheme has been deposited at the Civic Offices, Benalla, and at the Office of the Town and Country Planning Board, 235 Queen Street, Melbourne, and will be open for inspection during office hours by any person free of charge.

Any persons affected by the Planning Scheme are required to set forth in writing all objections they may have, addressed to the Town Clerk, City of Benalla, Fawckner Drive, Benalla, on or before the 16th day of March, 1977, and to state whether they wish to be heard in respect of their objections.

Dated 16th February, 1977.

6233

L. A. HEMLEY, Town Clerk.

Town and Country Planning Act 1961 (Twelfth Schedule).  
CITY OF BENALLA PLANNING SCHEME.

NOTICE THAT A PLANNING SCHEME HAS BEEN PREPARED  
AND IS AVAILABLE FOR INSPECTION.

## Amendment No. 11.

Notice is hereby given that the City of Benalla in pursuance of its powers under the *Town and Country Planning Act 1961* has prepared a Planning Scheme for:—

Rezoning an area comprising approximately 18 hectares of land being parts of Crown allotments 1, 2, 3A, and 4b, section 5, Witt Street, Benalla, from Restricted General Industrial to Reserved Residential.

A copy of the Scheme has been deposited at the Civic Offices, Benalla, and at the office of the Town and Country Planning Board, 235 Queen Street, Melbourne, and will be open for inspection during office hours by any person free of charge.

Any persons affected by the Planning Scheme are required to set forth in writing all objections they may have, addressed to the Town Clerk, City of Benalla, Fawckner Drive, Benalla, on or before the 16th day of March, 1977, and to state whether they wish to be heard in respect of their objections.

Dated 16th February, 1977.

6234

L. A. HEMLEY, Town Clerk.

Town and Country Planning Act 1961 (Twelfth Schedule).  
CITY OF BENDIGO PLANNING SCHEME 1962.

NOTICE THAT A PLANNING SCHEME HAS BEEN PREPARED  
AND IS AVAILABLE FOR INSPECTION.

## Amendment No. 21, 1977.

Notice is hereby given that the Council of the City of Bendigo in pursuance of its powers under the *Town and Country Planning Act 1961*, has prepared an Amending Planning Scheme for:—

All the land shown within the edge of the black border of the map comprising Schedule 1 and having frontages to Laurel Street of 55.18 metres, High Street 88.06 metres and Booth Street 47.75 metres and frontage to Bendigo Creek Reserve, and containing Crown allotments 4, 5, 5A, 5B, 8A, 9A, 10, 11 and 11A, section 38A, Parish of Sandhurst, County of Bendigo, to be re-zoned from "Residential" to "Commercial 'B'".

A copy of the Scheme has been deposited at the Offices of the City of Bendigo, 3550, and at the Office of the Town and Country Planning Board, 235 Queen Street, Melbourne, 3000, and will be open for inspection during office hours by any person, free of charge.

Any person affected by the Planning Scheme, are required to set forth in writing all objections they may have, addressed to:—

The Town Clerk, City of Bendigo, Municipal Offices, Lyttleton Terrace, Bendigo, 3550,  
on or before the 16th day of March, 1977, and to state whether they wish to be heard in respect of their objections.

6235

A. J. WATTS, Town Clerk.

Town and Country Planning Act 1961, Twelfth Schedule.  
CITY OF BENDIGO PLANNING SCHEME 1962.

NOTICE THAT A PLANNING SCHEME HAS BEEN PREPARED AND  
IS AVAILABLE FOR INSPECTION.

## Amendment No. 23, 1977.

Notice is hereby given that the Council of the City of Bendigo in pursuance of its powers under the *Town and Country Planning Act 1961*, has prepared an Amending Planning Scheme for:—

All the land enclosed within the black border of the map comprising Schedule 1 commencing 44.86 metres north-westerly of the intersection of Forest Street and High Street, and comprising the whole of Crown Allotment 7, Section 2b known as 7 Forest Street, Bendigo to be re-zoned from "Residential" to "Commercial 'A'".

A copy of the Scheme has been deposited at the Offices of the City of Bendigo, Municipal Offices, Lyttleton Terrace, Bendigo, 3550, and at the Office of the Town and Country

Planning Board, 235 Queen Street, Melbourne, 3000, and will be open for inspection during office hours by any person, free of charge.

Any person affected by the Planning Scheme, are required to set forth in writing, all objections they may have addressed to:—

The Town Clerk, City of Bendigo, Municipal Offices, Lyttleton Terrace, Bendigo, 3550,

on or before the sixteenth day of March, 1977, and to state whether they wish to be heard in respect of their objections.

6286

A. J. WATTS, Town Clerk.

*Town and Country Planning Act 1961 (Twelfth Schedule).*  
CITY OF KNOX PLANNING SCHEME 1965.

NOTICE THAT A PLANNING SCHEME HAS BEEN PREPARED  
AND IS AVAILABLE FOR INSPECTION.

*Amendment No. 169, 1976.*

Notice is hereby given that the Council of the City of Knox in pursuance of its powers under the *Town and Country Planning Act 1961*, has prepared a Planning Scheme for portions of the City of Knox for the purpose of amending the Principal Scheme by amending the subdivisional requirements pertaining to the Residential Development Zone.

A copy of the Scheme has been deposited at the Office of the City of Knox, Civic Centre, 511 Burwood Highway, Knoxfield, and at the Office of the Town and Country Planning Board, 5th Floor, 235 Queen Street, Melbourne and will be open for inspection during office hours by any person free of charge.

Any persons affected by the Planning Scheme are required to set forth in writing all objections they may have, addressed to the Town Clerk, City of Knox, Civic Centre, Knoxfield, on or before the 16th day of March, 1977, and to state whether they wish to be heard in respect of their objections.

Dated 8th February, 1977.

6218

T. J. NEVILLE, Town Clerk.

*Town and Country Planning Act 1961 (Twelfth Schedule).*  
CITY OF KNOX PLANNING SCHEME 1965.

NOTICE THAT A PLANNING SCHEME HAS BEEN PREPARED  
AND IS AVAILABLE FOR INSPECTION.

*Amendment No. 170, 1976.*

Notice is hereby given that the Council of the City of Knox in pursuance of its powers under the *Town and Country Planning Act 1961*, has prepared a Planning Scheme for portions of the City of Knox for the purpose of amending the Principal Scheme by—

- (a) including within Clause 25 (A) of the City of Knox Planning Scheme, an additional Public Purpose Reserve, numbered 13 and entitled Country Roads Board;
- (b) rezoning land situated on the west side of Lysterfield Road, Fern Tree Gully, being part of Crown allotment 52A, Parish of Scoresby, from Public Purposes Reserve—Municipal Purposes 1b (Engineers Depot) to Public Purposes Reserve 13—Country Roads Board.

A copy of the Scheme has been deposited at the Office of the City of Knox, Civic Centre, 511 Burwood Highway, Knoxfield, and at the Office of the Town and Country Planning Board, 5th Floor, 235 Queen Street, Melbourne and will be open for inspection during office hours by any person free of charge.

Any persons affected by the Planning Scheme are required to set forth in writing all objections they may have, addressed to the Town Clerk, City of Knox, Civic Centre, Knoxfield, on or before the 16th day of March, 1977, and to state whether they wish to be heard in respect of their objections.

Dated 8th February, 1977.

6219

T. J. NEVILLE, Town Clerk.

*Town and Country Planning Act 1961 (Twelfth Schedule).*  
CITY OF KNOX PLANNING SCHEME 1965.

NOTICE THAT A PLANNING SCHEME HAS BEEN PREPARED  
AND IS AVAILABLE FOR INSPECTION.

*Amendment No. 171, 1976.*

Notice is hereby given that the Council of the City of Knox in pursuance of its powers under the *Town and Country Planning Act 1961*, has prepared a Planning Scheme for portions of the City of Knox for the purpose of amending the Principal Scheme by rezoning land situated on the south-east corner of Mountain Highway and

Boronia Road, Wantirna, being part of Crown allotment 34A, Parish of Scoresby, from Light Industrial Zone to Commercial General Zone.

A copy of the Scheme has been deposited at the Office of the City of Knox, Civic Centre, 511 Burwood Highway, Knoxfield, and at the Office of the Town and Country Planning Board, 5th Floor, 235 Queen Street, Melbourne and will be open for inspection during office hours by any person free of charge.

Any persons affected by the Planning Scheme are required to set forth in writing all objections they may have, addressed to the Town Clerk, City of Knox, Civic Centre, Knoxfield, on or before the 16th day of March, 1977, and to state whether they wish to be heard in respect of their objections.

Dated 8th February, 1977.

6220

T. J. NEVILLE, Town Clerk.

*Town and Country Planning Act 1961 (Twelfth Schedule).*  
CITY OF KNOX PLANNING SCHEME 1965.

NOTICE THAT A PLANNING SCHEME HAS BEEN PREPARED  
AND IS AVAILABLE FOR INSPECTION.

*Amendment No. 172, 1976.*

Notice is hereby given that the Council of the City of Knox in pursuance of its powers under the *Town and Country Planning Act 1961*, has prepared a Planning Scheme for portions of the City of Knox for the purpose of amending the Principal Scheme by rezoning land situated on the south side of Burwood Highway between Lynne Avenue and Riddell Road, Wantirna South, being part of Crown allotment 42, Parish of Scoresby, from Residential Development Zone to Special Uses Zone F—Aged Peoples Homes.

A copy of the Scheme has been deposited at the Office of the City of Knox, Civic Centre, 511 Burwood Highway, Knoxfield, and at the Office of the Town and Country Planning Board, 5th Floor, 235 Queen Street, Melbourne and will be open for inspection during office hours by any person free of charge.

Any persons affected by the Planning Scheme are required to set forth in writing all objections they may have, addressed to the Town Clerk, City of Knox, Civic Centre, Knoxfield, on or before the 16th day of March, 1977, and to state whether they wish to be heard in respect of their objections.

Dated 8th February, 1977.

6221

T. J. NEVILLE, Town Clerk.

*Town and Country Planning Act 1961 (Twelfth Schedule).*  
CITY OF KNOX PLANNING SCHEME 1965.

NOTICE THAT A PLANNING SCHEME HAS BEEN PREPARED  
AND IS AVAILABLE FOR INSPECTION.

*Amendment No. 174, 1976.*

Notice is hereby given that the Council of the City of Knox in pursuance of its powers under the *Town and Country Planning Act 1961*, has prepared a Planning Scheme for portions of the City of Knox for the purpose of amending the Principal Scheme by amending the Planning Scheme Ordinance to include in the Rural A Zone in the column headed "Uses Permitted Subject to Conditions", an additional use entitled "Clubrooms".

A copy of the Scheme has been deposited at the Office of the City of Knox, Civic Centre, 511 Burwood Highway, Knoxfield, and at the Office of the Town and Country Planning Board, 5th Floor, 235 Queen Street, Melbourne and will be open for inspection during office hours by any person free of charge.

Any persons affected by the Planning Scheme are required to set forth in writing all objections they may have, addressed to the Town Clerk, City of Knox, Civic Centre, Knoxfield, on or before the 16th day of March, 1977, and to state whether they wish to be heard in respect of their objections.

Dated 8th February, 1977.

6222

T. J. NEVILLE, Town Clerk.

## CITY OF NORTHCOTE.

LOAN No. 130.

*Notice of Intention to Borrow the Sum of \$300,000 for Permanent Works and Undertakings.*

Notice is hereby given that the Council of the City of Northcote proposes to borrow the principal sum of Three hundred thousand dollars (\$300,000) secured by a charge over the general rates of the Municipality, such sum to be raised by the grant of a mortgage in accordance with the provisions of the *Local Government Act 1958* (as amended).

In connection therewith the following information is stated:—

1. The maximum rate of interest that may be paid is 10.7 per cent per annum.
2. The purposes for which the loan is to be applied are:

Construction of Roads and Drains	\$180,000
Improvements to Parks and Reserves	\$40,000
Construction of new Buildings	\$80,000

\$300,000

3. The period of the loan shall be fifteen (15) years.
4. The moneys borrowed shall be repayable by providing out of the Municipal Fund thirty (30) half-yearly instalments of approximately \$20,300.88 each including principal and interest on the first day of April and the first day of October during the currency of the loan. The first instalment shall be payable on the first day of October, 1977.
5. The place such moneys shall be repayable is at the office of the Commonwealth Savings Bank of Australia, Melbourne or such other places as the lender may direct.

The plans and specifications and estimates of the cost of the proposed works and a statement showing the proposed expenditure of the moneys to be borrowed are open for inspection at the offices of the Council of the City of Northcote, High Street, Northcote during office hours.

Dated at Northcote this 15th day of February, 1977.

6244 A. J. HILL, Town Clerk and City Manager.

#### CITY OF NORTHCOTE.

##### LOAN No. 129.

*Notice of Intention to Borrow the Sum of \$200,000 for Capital Works in the Electricity Supply Undertaking.*

Notice is hereby given that the Council of the City of Northcote proposes to borrow the principal sum of Two hundred thousand dollars (\$200,000) secured by a charge over the general rates of the Municipality, such sum to be raised by the grant of a mortgage in accordance with the provisions of the *Local Government Act 1958* (as amended).

In connection therewith the following information is stated:—

1. The maximum rate of interest that may be paid is 10.7 per cent per annum.
2. The purpose for which the loan is to be applied is for Capital Works in the Electricity Supply Undertaking.
3. The period of the loan shall be fifteen (15) years.
4. The moneys borrowed shall be repayable by providing out of the Municipal Fund thirty (30) half-yearly instalments of approximately \$13,533.92 each including principal and interest on the 1st day of April and the 1st day of October during the currency of the loan. The first instalment shall be payable on the 1st day of October, 1977.
5. The place such moneys shall be repayable is at the office of the Commonwealth Savings Bank of Australia, Melbourne or such other places as the lender may direct.

The plans and specifications and estimates of the cost of the proposed works and a statement showing the proposed expenditure of the moneys to be borrowed are open for inspection at the office of the Council of the City of Northcote, High Street, Northcote, during office hours.

Dated at Northcote this 15th day of February, 1977.

6243 A. J. HILL, Town Clerk and City Manager.

#### CITY OF PRESTON:

##### LOAN No. 109.

##### *Notice of Intention to Borrow.*

Notice is hereby given that the Council of the City of Preston intends to borrow the sum of \$600,000 (Six Hundred Thousand Dollars) by the grant of a Mortgage secured by a charge over the General Rates of the municipality in accordance with the provisions of the *Local Government Acts*.

In connection therewith, the following information is stated:—

- (a) The amount of the principal moneys which it is proposed to borrow is \$600,000.
- (b) The maximum rate of interest that may be paid is 10.7 per centum per annum.

- (c) The times which the moneys borrowed are to be repayable are the thirtieth day of September, 1977 and the thirty-first day of March and thirtieth day of September during the years 1978 to 1996 (inclusive) and a final payment on the thirty-first day of March, 1997 and that the place such moneys shall be repayable is at the Bank of New South Wales, Preston.

- (d) The purposes for which the Loan is to be applied are—

Electricity Department—Capital Expenditure	\$160,000
Purinan Road Underground Drain	50,000
Blake Street Kindergarten Acquisition	40,000
Municipal Buildings Extension—Alteration and Furnishing	107,500
Reservoir Senior Citizens Club extensions	50,000
Edwardes Park Improvements	2,000
Crispe Park—Automatic Watering System	8,000
Adams Park—Automatic Watering System and Improvements	7,500
Council Contribution—Country Roads Board Works	50,000

##### Road Construction and Reconstruction:

Lockton Avenue	\$16,000
Collins Street	45,000
Fitzroy Street	21,000
Yann Street	13,000
Larne Grove	30,000
	125,000

\$600,000

- (e) The manner in which the Loan is to be liquidated is by provision out of the Municipal Fund in each half-year during the currency of the Loan of the sum of \$36,658.15 which includes Principal and Interest.

The plans and specifications and estimate of the cost of the works and a statement showing the proposed expenditure of the moneys to be borrowed are open for inspection at the Town Hall, Preston, during office hours.

Dated this 14th day of February, 1977.

6290

N. E. L. ROBINSON, Town Clerk.

#### CITY OF SANDRINGHAM.

##### LOAN No. 122.

*Notice of Intention to Borrow the Sum of \$250,000 for Permanent Works and Undertakings.*

Notice is hereby given that the Council of the City of Sandringham intends to borrow Two Hundred and Fifty Thousand Dollars (\$250,000) secured by a charge over the general rates of the municipality by the grant of a mortgage in accordance with the provisions of the *Local Government Act 1958*.

In connection therewith the following information is stated:—

1. The amount of the principal moneys which it is proposed to borrow is \$250,000.
2. The maximum rate of interest that may be paid is 11 per centum per annum.
3. The period of the loan shall be 20 years.
4. The times at which the moneys borrowed are to be repayable are the 15th day of April and the 15th day of October in each year during the currency of the loan. The first instalment shall be payable on the 15th day of October, 1977 and the final instalment on the 15th day of April, 1997.
5. The place at which the moneys borrowed are to be repayable is the Local Authorities Superannuation Board, 15 Queens Road, Melbourne, or such other place as the Board from time to time may require.
6. The purpose for which the loan is to be applied is the part cost of an Indoor Community Recreation Centre at south west corner of Reserve Road and Tulip Street within the City of Sandringham.
7. The manner in which the loan is to be liquidated is by the provision out of the Municipal Fund in each half year during the currency of the loan of the sum of \$15,580.08 which includes principal and interest.

The plans, specifications and estimate of the cost of works and a statement showing the proposed expenditure of the moneys to be borrowed are open for inspection at the Municipal Offices, Royal Avenue, Sandringham.

Dated this 16th day of February, 1977.

6289

P. S. SHERMAN, Town Clerk.



## CITY OF WILLIAMSTOWN.

## LOAN NO. 67.

*Notice of Intention to Borrow the Sum of \$100,000 for Permanent Works and Undertakings.*

Notice is hereby given that the Council of the City of Williamstown proposes to borrow the principal sum of One Hundred Thousand Dollars (\$100,000), secured by a charge over the general rates of the Municipality, such sum to be raised by the grant of a mortgage, in accordance with the provisions of the *Local Government Act 1958* (as amended).

1. The maximum rate of interest that may be paid is 11.0 per cent. per annum.

2. The purpose for which the loan is to be applied—

Electric Supply—capital equipment	\$100,000
	\$100,000

3. The period of the loan shall be fifteen years.

4. The moneys borrowed shall be repayable by providing out of the Municipal fund 30 half-yearly instalments of \$6,880.54 each, including principal and interest on the 31st day of March and on the 30th day of September during the currency of the loan. The first instalment shall be payable on the 30th day of September, 1977.

5. Such moneys shall be repayable at the Commonwealth Savings Bank of Australia, Williamstown.

The Plans and Specifications and the estimate of the cost of the proposed works and a statement showing the proposed expenditure of the moneys to be borrowed, are open for inspection at the Office of the Council of the City of Williamstown, at the Municipal Offices, 104 Ferguson Street, Williamstown.

6225 J. T. SLOAN, Town Clerk (Elect).

## SHIRE OF ALEXANDRA.

## LOAN NO. 40

*Notice of Intention to Borrow the Sum of \$52,500 for Permanent Works and Undertakings.*

Notice is hereby given that the Council of the Shire of Alexandra proposes to borrow the principal sum of Fifty-two thousand and five hundred dollars (\$52,500) secured by a charge over the general rates of the municipality, such sum to be raised by the grant of a mortgage in accordance with the provisions of the *Local Government Act 1958*.

1. The maximum rate of interest that may be paid is 11.0 per centum per annum.

2. The purposes for which the loan is to be applied is:

1. Township Roadworks	\$32,500
2. Shire Hall Restoration (Part)	\$20,000
	\$52,500

3. The period of the loan shall be 20 years.

4. The moneys borrowed shall be repayable by half-yearly instalments of approximately \$3,271.82 including principal and interest on the first day of April, and the first day of October during the currency of the loan. The first instalment shall be repayable on the first day of October, 1977.

5. Such moneys shall be repayable at the State Bank, Alexandra.

The plans and specifications and the estimate of the cost of the proposed works and a statement showing the proposed expenditure of the moneys to be borrowed are open for inspection at the office of the Council of the Shire of Alexandra, Perkins Street, Alexandra.

6231 G. I. WALSHE, Shire Secretary.

## SHIRE OF ALEXANDRA.

## LOAN NO. 41

*Notice of Intention to Borrow the Sum of \$40,000 for Permanent Works and Undertakings.*

Notice is hereby given that the Council of the Shire of Alexandra proposes to borrow the principal sum of Forty thousand dollars (\$40,000) secured by a charge over the general rates of the municipality, such sum to be raised by the grant of a mortgage in accordance with the provisions of the *Local Government Act 1958*.

1. The maximum rate of interest that may be paid is 10.8 per centum per annum.

2. The purpose for which the loan is to be applied is: Purchase of Plant.

3. The period of the loan shall be 7 years.

No. 10.—960/77.—4

4. The moneys borrowed shall be repayable by half-yearly instalments of approximately \$4,144.96 including principal and interest on the first day of April, and the first day of October during the currency of the loan. The first instalment shall be repayable on the first day of October, 1977.

5. Such moneys shall be repayable at the National Bank of Australasia, Alexandra.

The plans and specifications and the estimate of the cost of the proposed works and a statement showing the proposed expenditure of the moneys to be borrowed are open for inspection at the office of the Council of the Shire of Alexandra, Perkins Street, Alexandra.

6232 G. I. WALSHE, Shire Secretary.

## SHIRE OF BET BET.

## LOAN NO. 26.

*Notice of Intention to Borrow the Sum of \$30,000 for Permanent Works and Undertakings.*

Notice is hereby given that the Council of the Shire of Bet Bet proposes to borrow the principal sum of Thirty Thousand Dollars secured by a charge over the general rates of the municipality, such sum to be raised by the grant of a mortgage in accordance with the provisions of the *Local Government Act 1958*.

1. The maximum rate of interest that may be paid is 10.6 per cent. per annum.

2. The purpose for which the loan is to be applied is—

Purchase of road making plant. (1 Tip Truck, 1 Front End Loader.)

3. The period of the loan shall be six years.

4. The moneys borrowed shall be repayable by providing out of the municipal fund half-yearly instalments of approximately \$3,442.28 each including principal and interest on the first day of November and the first day of May during the currency of the loan. The first instalment shall be payable on the first day of November, 1977.

5. Such moneys shall be repayable to The Commissioners of The State Savings Bank of Victoria at the office of the said Commissioners, 233 Collins Street, Melbourne.

The plans and specifications and the estimate of the cost of the proposed works and a statement showing the proposed expenditure of the moneys to be borrowed are open for inspection at the office of the Council of the Shire of Bet Bet, at Dunolly.

Dated 11th February, 1977.

6236 BRIAN F. O'CONNOR, Acting Shire Secretary.

## SHIRE OF BET BET.

## LOAN NO. 27.

*Notice of Intention to Borrow the Sum of \$9,000 for Permanent Works and Undertakings.*

Notice is hereby given that the Council of the Shire of Bet Bet proposes to borrow the principal sum of Nine Thousand Dollars secured by a charge over the general rates of the municipality, such sum to be raised by the grant of a mortgage in accordance with the provisions of the *Local Government Act 1958*.

1. The maximum rate of interest that may be paid is 11 per cent. per annum.

2. The purpose for which the loan is to be applied is—

Construction of Kerb and Channelling, Newbridge and Dunolly Townships.

3. The period of the loan shall be fifteen years.

4. The moneys borrowed shall be repayable by providing out of the municipal fund half-yearly instalments of approximately \$619.25 each including principal and interest on the first day of November and the first day of May during the currency of the loan. The first instalment shall be payable on the first day of November, 1977.

5. Such moneys shall be repayable to The Commissioners of The State Savings Bank of Victoria at the office of the said Commissioners, 233 Collins Street, Melbourne.

The plans and specifications and the estimate of the cost of the proposed works and a statement showing the proposed expenditure of the moneys to be borrowed are open for inspection at the office of the Council of the Shire of Bet Bet, at Dunolly.

Dated 11th February, 1977.

6237 BRIAN F. O'CONNOR, Acting Shire Secretary.

## SHIRE OF BULN BULN.

## LOAN No. 81.

*Notice of Intention to Borrow the Sum of \$100,000 for Permanent Works and Undertakings.*

Notice is hereby given that the Council of the Shire of Buln Buln proposes to borrow the principal sum of \$100,000 secured by a charge over the general rates of the municipality, such sum to be raised by the grant of a mortgage in accordance with the provisions of the *Local Government Act 1958*.

1. The maximum rate of interest that may be paid is 11 per cent. per annum.
2. The purpose for which the loan is to be applied is—  
Township street construction—(Hope Street, Roberts Road, Longwarry Road, Russell Street, Viaduct Place, Church Street, Waddell Road, Hearn Street, Princes Avenue, Kennedy Street, Drouin Road (part cost) .. .. . \$86,000  
Car parking areas construction .. .. . 4,000  
Development of Council Depots .. .. . 10,000  
\$100,000

3. The period of the loan shall be 15 years.

4. The moneys borrowed shall be repayable by providing out of the municipal fund half-yearly instalments of approximately \$6,880.54 each including principal and interest on the first day of April and the first day of October during the currency of the loan. The first instalment shall be payable on the first day of October, 1977.

5. Such moneys shall be repayable to The Commissioners of the State Savings Bank of Victoria at the office of the said Commissioners, 233 Collins Street, Melbourne, 3000.

The plans and specifications and the estimate of the cost of the proposed works and a statement showing the proposed expenditure of the moneys to be borrowed are open for inspection at the office of the Council of the Shire of Buln Buln, at Drouin.

Dated 2nd February, 1977.

6189 K. A. PRETTY, Shire Secretary.

## SHIRE OF DIAMOND VALLEY.

## LOAN No. 53.

*Notice of Intention to Borrow the Sum of \$300,000 for Permanent Works and Undertakings.*

Notice is hereby given that the Council of the Shire of Diamond Valley proposes to borrow the principal sum of \$300,000 secured by a charge over the general rates of the municipality, such sum to be raised by the grant of a mortgage in accordance with the provisions of the *Local Government Act 1958*.

1. The maximum rate of interest that may be paid is 11% per annum.
2. The purposes for which the loan is to be applied are—  
Land purchases—  
Public open space purchase and repayments (pt. prov.) .. .. . \$146,100  
Buildings—  
Bundoora Hall—extensions (pt. prov.) .. .. . \$34,100  
Greenhills Hall—extensions (pt. prov.) .. .. . 15,000  
49,100  
Purchase of equipment — accounting machine .. .. . 35,000  
Parkway Reserve—provision of adventure playground .. .. . 5,000  
Public Works—C.R.B. works—Council's proportion (pt. prov.) .. .. . 64,800  
\$300,000

3. The period of the loan shall be 15 years.

4. The moneys borrowed shall be repayable by providing out of the municipal fund half-yearly instalments of \$20,641.62 each including principal and interest on the 1st day of April and the 1st day of October during the currency of the loan. The first instalment shall be payable on the 1st October, 1977.

5. Such moneys shall be repayable to the Commonwealth Savings Bank of Australia, Melbourne.

The plans and specifications and the estimate of the cost of the proposed works and a statement showing the proposed expenditure of the moneys to be borrowed are open for inspection at the office of the Council of the Shire of Diamond Valley, Civic Drive, Greensborough.

6217

B. J. MORGAN, Shire Secretary.

## SHIRE OF FLINDERS.

## LOAN No. 104.

*Notice of Intention to Borrow.*

Notice is hereby given that the Council of the Shire of Flinders intends to borrow \$100,000 secured by a charge over the general rates of the Municipality, such sum to be raised by the grant of a mortgage in accordance with the provisions of the *Local Government Act 1958*.

(a) The maximum rate of interest that may be paid is 11 per centum per annum.

(b) The amount of the principal moneys which it is to borrow is One Hundred Thousand Dollars.

(c) The period of the loan shall be twenty (20) years.

(d) The purposes for which the loan is to be applied:—  
Rye boat ramp construction .. .. . \$60,000.00  
Development of Reserve—Shearwater Place (part provision) .. .. . 40,000.00

(e) The moneys shall be repayable by paying out of the municipal fund half-yearly instalments of approximately \$6,232.04 each including principal and interest on the first day of April and the first day of October during the currency of the loan.

The first instalment shall be payable on the first day of October, 1977.

(f) Such moneys shall be repayable to the Commissioners of the State Savings Bank of Victoria at the office of the said Commissioners, 233 Collins Street, Melbourne.

The plans and specifications and the estimate of the cost of the proposed works and a statement showing the proposed expenditure of the moneys to be borrowed are open for inspection at the offices of the Council of the Shire of Flinders at the Municipal Offices, Boneo Road, Rosebud.

16th February, 1977.

6238 G. W. WHITE, Acting Shire Secretary.

## SHIRE OF GORDON.

*Prohibited Area for Dogs.*

Notice is hereby given that the Council of the Shire of Gordon by resolution, in accordance with the provisions of section 16 of the *Dog Act 1958*, has prohibited as from 1st June, 1977, the following area within the Township of Boort.

All that area bounded by the foreshore of Little Lake Boort, Caravan Park Amenities Block, Godfrey Street and the Tennis Club East fence.

By order,

6199 D. D. WRIGHT, Shire Secretary.

## SHIRE OF HAMPDEN.

## LOAN No. 22.

*Notice of Intention to Borrow the Sum of \$100,000 for Permanent Works and Undertakings.*

Notice is hereby given that the Council of the Shire of Hampden proposes to borrow the sum of One hundred thousand dollars (\$100,000) secured by a charge over the general rates of the municipality, such sum to be raised by the grant of a mortgage in accordance with the provisions of the *Local Government Act 1958*.

1. The maximum rate of interest that may be paid is 11 per cent. per annum.

2. The purpose for which the loan is to be applied is:—  
Purchase of roadmaking plant .. .. . \$20,000  
Stage 1 of Terang Sports Complex .. .. . 80,000  
\$100,000

3. The period of the loan shall be twenty (20) years.

4. The moneys borrowed shall be repayable by providing out of the municipal fund 40 half yearly instalments of approximately \$6,232.03 each including principal and interest on the 15th day of April and the 15th day of October in each year during the currency of the loan.

The first instalment shall be repayable on the 15th day of October 1977.

5. Such moneys shall be repayable to the National Bank of Australasia Limited, Melbourne, or at the Council's bankers for the time being in Melbourne.

The plans and specifications and estimates of the costs of the proposed works and a statement showing the proposed expenditure of the moneys to be borrowed, are open for inspection at the Shire Office, Camperdown.

Dated the 9th day of February, 1977.

6200

S. J. GRIMMER, Shire Secretary.

## SHIRE OF HASTINGS.

## LOAN No. 66.

*Notice of Intention to Borrow the Sum of \$50,000 for Permanent Works and Undertakings.*

Notice is hereby given that the Council of the Shire of Hastings proposes to borrow the principal sum of Fifty thousand dollars, (\$50,000), secured by a charge over the General Rates of the Municipality, such sum to be raised by the grant of a Mortgage in accordance with the provisions of the *Local Government Act 1958*.

1. The maximum rate of interest that may be paid, is 10.9 per cent. per annum.
2. The purpose for which the Loan is to be applied, is—

Purchase of land and building for a Day Child-Care Centre, in Salmon Street, Hastings.

3. The period of the Loan shall be 10 years.
4. The moneys borrowed shall be repayable by providing out of the Municipal Fund, half-yearly instalments of \$4,166.63 each, including Principal and Interest, on the 10th day of October and the 10th day of April during the currency of the Loan.

The first instalment shall be payable on the 10th day of October, 1977.

5. Such moneys shall be repayable to the National Bank Savings Bank Limited, at 271 Collins Street, Melbourne.

The Plans, Specifications and estimate of the cost of the proposed works, and a statement showing the proposed expenditure of the moneys to be borrowed, are open for inspection at the Office of the Council of the Shire of Hastings, Marine Parade, Hastings.

11th February, 1977.

L. A. WALKER, Shire Secretary.

Municipal Offices, Hastings; 3915. 6239

## SHIRE OF KILMORE.

## LOAN No. 51.

*Notice of Intention to Borrow the Sum of \$100,000 for Permanent Works and Undertakings.*

Notice is hereby given that the Council of the Shire of Kilmore proposes to borrow the principal sum of One hundred thousand dollars by the grant of a mortgage in accordance with the provisions of the *Local Government Act 1958*.

1. The maximum rate of interest that may be paid is 11.0 per cent per annum.
2. The purpose for which the loan is to be applied is part construction of municipal offices.
3. The period of the loan shall be 20 years.
4. The moneys borrowed shall be repayable by providing out of the municipal fund half-yearly instalments of approximately \$6,232.04 each including principal and interest on the first day of May and the first day of November during the currency of the loan. The first instalment shall be payable on the first day of November, 1977.

5. Such moneys shall be repayable to the commissioners of the State Savings Bank of Victoria at the office of the said commissioners, 233 Collins Street, Melbourne.

The plans and specifications and the estimate of the cost of the proposed works and a statement showing the proposed expenditure of the moneys to be borrowed are open for inspection at the office of the Council of the Shire of Kilmore at 16 Sydney Street, Kilmore.

Dated 16th February, 1977.

6240 JIM ELVEY, Shire Secretary.

## SHIRE OF KILMORE.

## LOAN No. 53.

*Notice of Intention to Borrow the Sum of \$200,000 for Permanent Works and Undertakings.*

Notice is hereby given that the Council of the Shire of Kilmore proposes to borrow the principal sum of \$200,000 secured by a charge over the general rates of the municipality, such sum to be raised by the grant of a mortgage in accordance with the provisions of the *Local Government Act 1958*.

1. The maximum rate of interest that may be paid is 11.0 per cent. per annum.
2. The purpose for which the loan is to be applied is part construction of Municipal Office Complex.
3. The period of the loan shall be 20 years.

4. The moneys borrowed shall be repayable by providing out of the municipal fund half-yearly instalments of approximately \$12,464.07 including principal and interest on the first day of January and the first day of July during the currency of the loan. The first instalment shall be payable on the first day of January, 1978.

5. Such moneys shall be repayable to the Commercial Banking Company of Sydney Limited, Melbourne.

The plans and specifications of the estimate of the cost of the proposed works and a statement showing the proposed expenditure of the moneys to be borrowed are open for inspection at the office of the Council of the Shire of Kilmore, at Sydney Street, Kilmore.

Dated 16th February, 1977.

6241 J. A. ELVEY, Shire Secretary.

## SHIRE OF KOWREE.

The Shire of Kowree hereby appoints Sergeant John T. Jones, No. 13677, as a Prosecuting Officer for the Shire of Kowree following transfer of Sergeant William Hager.

6242 B. D. HAYES, Shire Secretary.

## SHIRE OF MAFFRA.

## EXTENSION OF MAFFRA POUND.

Notice is hereby given that the Council has appointed as from the 16th February, 1977, the following area of land as an extension to the Maffra Pound—

Part of C.A. 1A, Parish of Wa-de-lock, County of Tanjil, more particularly described in Certificate of Title Volume 9176, Folio 744.

This area owned by the Council is adjacent to the Maffra Pound on the Maffra Stratford Road, Maffra.

6223 J. RENNICK, Shire Secretary.

## SHIRE OF MANSFIELD.

## LOAN No. 86.

*Notice of Intention to Borrow the Sum of \$28,000 for Permanent Works and Undertakings.*

Notice is hereby given that the Council of the Shire of Mansfield intends to borrow Twenty Eight Thousand Dollars (\$28,000) secured by a charge over the General Rates of the Municipality by the grant of a Mortgage in accordance with the provisions of the *Local Government Acts*.

In connection therewith the following information is stated:—

- (a) The amount of the principal moneys which it is proposed to borrow is \$28,000.
- (b) The times which the moneys borrowed are to be repayable are the 26th day of September, 1977 and the 25th days of March and September, during the years 1978–1980 inclusive and that the place such moneys shall be repayable is at the Bank of New South Wales, Mansfield.
- (c) The maximum rate of interest that may be paid is 10.1 per centum per annum.
- (d) The purpose for which the loan is to be applied is Permanent Works and Undertakings namely the purchase of Road Making Equipment.
- (e) The manner in which the loan is to be liquidated is by provision out of the Municipal Fund in each half-year during the currency of the loan of the sum of \$5,525.31 which includes principal and interest.

The plans and specifications and estimate of the cost of the works and a statement showing the proposed expenditure of the moneys to be borrowed are open for inspection at the Shire Office.

Dated this 8th day of February, 1977.

6201 E. CAIRNS, Shire Secretary.

## SHIRE OF MANSFIELD.

## LOAN No. 87.

*Notice of Intention to Borrow the Sum of \$58,000 for Permanent Works and Undertakings.*

Notice is hereby given that the Council of the Shire of Mansfield intends to borrow Fifty Eight Thousand Dollars (\$58,000) secured by a charge over the General Rates of the Municipality by the grant of a Mortgage in accordance with the provisions of the *Local Government Acts*.

In connection therewith the following information is stated:—

- (a) The amount of the principal moneys which it is proposed to borrow is \$58,000.

- (b) The times which the moneys borrowed are to be repayable are the 25th day of September, 1977, and the 25th days of March and September during the years 1978-1997 inclusive and that the place such moneys shall be repayable is at the Bank of New South Wales, Mansfield.
- (c) The maximum rate of interest that may be paid is 10.7 per centum per annum.
- (d) The purpose for which the loan is to be applied is Permanent Works and undertakings namely the acquisition of land and associated legal expenses for the proposed parking areas Nolan Street, Mansfield. And Early Street Mansfield and additional power outlets at Jamieson Caravan Park.
- (e) The manner in which the loan is to be liquidated is by provision out of the Municipal Fund in each half-year during currency of the Loan of the sum of \$3,543.62 which includes Principal and Interest.

The Plans and Specifications and estimate of the cost of the works and a statement showing the proposed expenditure of the moneys to be borrowed are open for inspection at the Shire Office.

Dated this 8th day of February, 1977.

6202 E. CAIRNS, Shire Secretary.

*Town and Country Planning Act 1961, Twelfth Schedule.*

SHIRE OF MORNINGTON PLANNING SCHEME 1959.

NOTICE THAT A PLANNING SCHEME HAS BEEN PREPARED AND IS AVAILABLE FOR INSPECTION.

Amendment No. 105A, 1977.

Notice is hereby given that the Council of the Shire of Mornington in pursuance of its powers under the *Town and Country Planning Act 1961* has prepared a Planning Scheme for the following areas and purposes:—

Land shown on Plan No. 278/PP/1 in the Office of the Council, comprising part of the land within the area bounded by Tyabb Road, Racecourse Road, Bentons Road and Dunns Road, Mornington, rezoning from Agricultural Zone to Residential Medium Density 3 Zone.

A copy of the Scheme has been deposited at the Office of the Council, Queen Street, Mornington, and at the Office of the Town and Country Planning Board, 235 Queen Street, Melbourne, and will be open for inspection during office hours by any person free of charge.

Any persons affected by the Planning Scheme are required to set forth in writing all objections they may have, addressed to the Shire Secretary, Mornington Shire Council, P.O. Box 78, Mornington, 3931, on or before the 16th March, 1977, and to state whether they wish to be heard in respect of their objections.

6288. D. G. COLLINGS, Shire Secretary.

SHIRE OF PAKENHAM.

LOAN No. 75.

*Notice of Intention to Borrow the Sum of \$300,000 for Permanent Works and Undertakings.*

Notice is hereby given that the Council of the Shire of Pakenham proposes to borrow the Principal Sum of Three Hundred Thousand Dollars (\$300,000), secured by a charge over the General Rates of the Municipality, such Sum to be raised by the grant of a Mortgage in accordance with the provisions of the *Local Government Act 1958*.

1. The maximum rate of Interest that may be paid is 11.00 Per Centum per annum.

2. The purpose for which the Loan is to be applied is:

Nar Nar Goon/Longwarry Road, Nar Nar Goon—Pavement widening adjacent to Post Office	\$2,010
Princes Highway Service Road/O'Shan-nessey Street, to Roman Catholic Church—Pakenham—Kerb, channel, drainage, pavement and seal	\$5,922
Garfield Road, Garfield—Complete kerb and channel, east side of Archers Road, west side to Robert's property	\$300
Station Street, Pakenham—Kerb, channel, drainage and pavement and seal	\$16,200
Tivendale Road, Officer—Extend pavement and seal to Poultry Farm	\$2,100
Souter Street, Beaconsfield—Private Street Construction Scheme Council Contribu-tion	\$2,338

Brennan's Estate, Beaconsfield Upper—Private Street Scheme—Council Con-tribution (Part)	\$42
Princes Highway Service Road, Pakenham —Private Street Construction Scheme Council Contribution	\$1,200
Pakenham—Central Depot Equipment	\$4,700
Cockatoo—Pre-School Construction	\$13,800
Pakenham—Shire Office, Connection to Sewer	\$2,500
Pakenham—Council House, 24 Main Street, Connection to the Sewer	\$1,000
Pakenham—Central Depot, Connection to the Sewer	\$3,600
Beaconsfield/Emerald Road, Emerald—east side Albert Road to Shire boundary—Underground—Drainage, kerb, channel and footpath	\$12,700
Princes Highway — Lyle Avenue to Glismann Road, Beaconsfield, north side, footpath, kerb, channel and drainage, pavement widening and seal	\$20,400
Tivendale Road, Officer—Footpath, High-way to School	\$1,100
Main Street, Gembrook—north side, foot-path—Station Road to School Car Park	\$1,500
John Street, Pakenham—east side, footpath —Princes Highway to Main Street	\$3,300
Henty Street, Pakenham—footpath, Charles Street to Savage Street	\$2,900
Main Street, Pakenham—north side, Concrete footpath—Stephenson Street to Princes Highway	\$2,600
Roger Street, Pakenham—west side, Con-crete footpath—Main Street to Wadsley Avenue	\$800
James Street, Pakenham—south side, Princes Highway to John Street and west side Princes Highway to Stephenson Street	\$2,000
Princes Highway Service Road, Pakenham —footpath, O'Shannessy Street to past Roman Catholic Church	\$1,600
Nar Nar Goon/Longwarry Road, Nar Nar Goon—Kerb, channel and underground drainage, Bayles/Nar Nar Goon Road to last house, footpath—Bayles/Nar Nar Goon Road to School entrance	\$9,700
Garfield Road, Garfield—east side, continue footpath northerly to Archer Road	\$700
Princes Highway, Officer—Service road, south side, final bituminous seal	\$1,500
Tivendale Road, Officer—Final bituminous seal	\$1,000
Tivendale Road, Officer—Enlarge culvert	\$3,000
Tivendale Road, Officer—west side, under-ground drainage, Highway to School	\$4,000
Souter Street, Beaconsfield—Playground Post and Rail Barrier along road frontage	\$1,850
Red Road, Gembrook—Form and Surface south of Community Complex site	\$2,000
Main Street, Gembrook—Reseal parking lanes in conjunction with C.R.B. reseal	\$1,000
Cockatoo—Public Notice Board replace-ment	\$60
Railway Avenue, Pakenham—Henry Street to Racecourse Road, Final bituminous seal	\$2,900
James Street, Pakenham—Resurfacing	\$10,000
Railway Avenue, Tynong—Final bituminous seal, View Street, easterly	\$1,200
High Street, Bunyip—central median War Memorial to Infant Welfare Centre Kerbing and Landscaping	\$5,500
High Street, Guys Hill—Land Acquisition for improved road alignment	\$4,500
Gembrook—Land Acquisition	\$8,000
Cockatoo—Land Acquisition	\$4,000
Cockatoo—Land Acquisition	\$15,000
Nar Nar Goon—Land Acquisition	\$24,000
Bunyip—Land Acquisition	\$34,313
Cockatoo—Development of Picnic Reserve, Healesville/Koo Wee Rup Road opposite View Hill Road	\$1,000
Cockatoo—Youth Club, provision of septic toilet facilities	\$225
Cockatoo—Youth Club—plumbing works	\$80
Pakenham—Swimming Pool connection to Sewer	\$3,000
Pakenham—The Heights Pre-School Centre connection to Sewer	\$400
Pakenham Senior Citizens Club—Connec-tion to Sewer	\$360

Gembrook Community Complex—Preparation of conceptual plan	\$1,000
Pakenham Upper—resurfacing of tennis courts	\$500
Beaconsfield Upper—Recreation Reserve, Construction of Public Conveniences	\$10,500
Cockatoo—Recreation Reserve, First Stage development and investigation	\$2,000
Cockatoo—Recreation facilities, Two netball courts, including lights and fence, asphalt surface	\$8,800
Cockatoo—Recreation facilities, Two tennis courts, en-tout-cas or plexipave	\$8,000
Tynong North—provision of asphalt tennis courts	\$7,800
Four Recreation Reserves—Grants to Committees of Management on a \$1 for \$1 basis for capital works. Maximum Grant for financial year to be \$500	\$2,000
Beaconsfield Upper—Tennis Club, improvements: tennis courts	\$2,500
Pakenham Bowling Club—construction of second green	\$600
Pakenham—improvements to Recreation facilities	\$6,000
Pakenham Recreation Reserve—First stage of construction of Sports Centre Car Park	\$3,600
Pakenham—Infant Welfare and Pre-School Centre, and flat connection to Sewer	\$2,200
Pakenham—Bald Hill Road, kerb, channel and underground drainage easterly to Hutmill	\$600
	<u>\$300,000</u>

3. The period of the Loan shall be Fifteen (15) Years.

4. The monies borrowed shall be repayable by providing out of the Municipal Fund Thirty (30) Half-Yearly instalments of \$20,641.62 each, including Principal and Interest, on the tenth (10th) Day of September, and tenth (10th) Day of March during the currency of the Loan.

The first instalment shall be payable on the tenth (10th) Day of September, 1977.

5. Such monies shall be repayable to the Commercial Savings Bank of Australia Limited, Main Street, Pakenham.

The plans and specifications and the estimate of the cost of the proposed works, and a statement, showing the proposed expenditure of the monies to be borrowed are open for inspection at the Office of the Council of the Shire of Pakenham at Main Street, Pakenham.

6203 B. J. WALLIS, Shire Secretary.

## SHIRE OF ROCHESTER.

## LOAN No. 31.

Notice is hereby given that the Council of the Shire of Rochester intends to borrow \$65,000 (Sixty-five thousand dollars), secured by a charge over the general rates of the municipality, by the grant of a mortgage, in accordance with the provisions of the Local Government Acts.

In connection therewith the following information is stated:—

- The amount of the principal moneys which it is proposed to borrow is Sixty-five thousand dollars (\$65,000).
- The maximum rate of interest that may be paid is 10.9 per centum per annum.
- The times which the moneys borrowed are to be repayable are the 1st day of November 1977, the 1st days of May and November during the years 1978–1991 inclusive, and that the place such moneys shall be repayable is at the Bank of New South Wales, Rochester.
- The purposes for which the loan is to be applied are:—

Main Street Gunbower Construction Service Road	\$5,000
Market Street Private Street Scheme Lockington, Council Contribution	\$3,000
Northcote Street Private Street Construction Scheme, Council Contribution	\$6,000
Off Street Parking, Rochester	\$5,000
Rochester Recreation Reserve Development, Council Contribution	\$26,000
Saleyards Improvements, Council Contribution to Grant	\$16,000
Gunbower Hall, Council Contribution to Subsidy	\$4,000
	<u>\$65,000</u>

- The manner in which the loan is to be liquidated is by provision out of the municipal fund in each half-year during the currency of the loan of the sum of \$4,578.68 which includes principal and interest.

The plans and specifications and estimate of the cost of the works and a statement showing the proposed expenditure of the moneys to be borrowed, are open for inspection at the Shire Office, Rochester.

Dated this 7th day of February, 1977.

6224 H. R. WESTCOTT, Shire Secretary.

## SHIRE OF SOUTH GIPPSLAND.

## DOGS ON BEACHES.

The Council of the Shire of South Gippsland did, at its meeting on February 3rd, 1977, resolve to prohibit dogs (not under the effective control of the owner) from all beaches in the Shire during the period December 1st to May 1st.

Offenders are warned that the penalty for infringement is \$50.

6204 H. R. LOMAX, Shire Secretary.

## SHIRE OF WARRNAMBOOL.

## LOAN 25.

*Notice of Intention to Borrow the Sum of \$91,000 for Permanent Works and Undertakings.*

Notice is hereby given that the Council of the Shire of Warrnambool proposes to borrow the principal sum of Ninety-one Thousand Dollars (\$91,000) secured by a charge over the General Rates of the municipality such sum to be raised by the grant of a mortgage in accordance with the provisions of the Local Government Act 1958.

- The maximum rate of interest that may be paid is 10.8 per centum per annum.
- The purposes for which the loan is to be applied are:—

Purchase of Roadmaking Plant .. ..	\$75,000
Office Equipment .. ..	\$16,000
	<u>\$91,000</u>

- The period of the loan shall be seven (7) years.
- The moneys borrowed shall be repayable by providing out of the Municipal Fund fourteen (14) equal half yearly instalments of \$9429.78, each containing principal and interest on the first day of May and the first day of November each year during the currency of the loan. The first instalment shall be repayable on 1st day of November, 1977.

5. Such moneys shall be repayable to the Commonwealth Savings Bank of Australia, Melbourne.

The plans and specifications and estimate of the cost of the proposed works and a statement showing the proposed expenditure of the moneys to be borrowed are open for inspection at the Shire Office, Warrnambool.

6291 ALAN J. BOWES, Shire Secretary.

## SHIRE OF WOORAYL.

## LOAN No. 57.

Notice is hereby given that the Council of the Shire of Woorayl proposes to borrow the sum of \$32,000 secured by the grant of a mortgage on the general rate revenue of the Council.

The maximum rate of interest to be paid shall be 10.9% per annum.

The purposes for which the loan is to be applied is—

- Council proportion Private Street Works \$26,700
- Part Cost Ventilation System—Shire Office \$5,300

The period of the loan shall be 10 years.

The monies borrowed shall be repayable by providing out of the municipal fund half yearly instalments of \$2,664.64 each, including principal and interest on the 15th day of March and September each year during the currency of the loan. The first repayment shall be due on the 15th day of September, 1977.

The monies shall be repayable at the office of the Commonwealth Savings Bank, Bair Street, Leongatha.

The plans and specifications and the estimate of the cost of the proposed works and a statement showing the proposed expenditure of the monies to be borrowed are open for inspection at the Shire Office, Leongatha.

6205 R. G. STANLEY, Shire Secretary.

## SHIRE OF YACKANDANDAH.

## LOAN No. 11.

*Notice of Intention to Borrow the Sum of \$27,000 for Permanent Works and Undertakings.*

Notice is hereby given that the Council of the Shire of Yackandandah proposes to borrow the sum of \$27,000, secured by a charge over the general rates of the Municipality, such sum to be raised by the grant of a mortgage in accordance with the provisions of the *Local Government Act 1958*.

1. The maximum rate of interest that may be paid is 10.5 per cent per annum.

2. Such moneys shall be payable to the Australian and New Zealand Savings Bank Limited, 394 Collins Street, Melbourne.

3. The period of the loan shall be ten years.

4. The loan is to be liquidated by providing out of the Municipal Fund twenty half-yearly instalments of approximately \$2,212.75 each including principal and interest on the 1st day of March and the 1st day of September during the currency of the loan. The first instalment shall be payable on the 1st day of September, 1977.

5. The loan is to be applied for the purchase of plant.

6. The plans, specifications and estimates of the cost of the proposed works and a statement showing the proposed expenditure are open for inspection at the Council Offices, Yackandandah, during office hours.

6246

T. H. FORBES, Shire Secretary.

## AVON RIVER IMPROVEMENT TRUST.

## By-Law No. 101.

A By-Law of the Avon River Improvement Trust made under the provisions of section 55 of the *River Improvement Act 1958* and numbered 101 for:—

- (a) preventing or minimizing interference with the flow of water in or the silting up of or injury to or pollution of any river, including prohibiting the depositing therein of any materials matters or substances likely to cause such interference silting up injury or pollution;
- (b) prohibiting or regulating the removal of soil earth gravel sand or other materials from the bed and banks of any river;
- (c) generally, the management and control of any river and the banks thereon and any river improvement works carried out constructed or in course of construction by the river improvement authority in connection therewith.

In pursuance and exercise of the powers conferred by the *River Improvement Act 1958* and of any and every other power it thereunto enabling the Avon River Improvement Trust doth hereby make the By-Law following:—

1. In this By-Law unless inconsistent with the context or subject matter—

“River Improvement Works” bears and has the same meaning as in the *River Improvement Act 1958*;

“Trust” means the Avon River Improvement Trust;  
“Trust Lands” means and includes any lands vested in or under the management or control of the Trust;

“Trust Works” means and includes river improvement works vested in or under the control or management of the Trust;

2. This By-Law shall apply to and have operation within all lands and over and upon all river improvement works vested in or under the management or control of the Trust;

3. This By-Law shall come into operation and have effect on its approval by the Governor in Council and immediately after its publication in the *Government Gazette*.

4. No person shall—

- (a) act or carry any activity in such a manner as to injure any person, or cause damage to any river improvement works; or
- (b) leave or deposit or cause to be left or deposited any rubbish of any kind; or

(c) damage, disfigure, displace or remove any notices; or

(d) roll, throw, discharge or cause to be rolled, thrown or discharged any stone, brick or other substance or substances as a missile.

5. No person shall without the prior written consent of the Trust or an Officer of the Trust duly authorised in that regard—

(a) operate or interfere with or cause to be operated or interfered with any Trust works; or

(b) cut down, remove, damage or destroy or cause to be cut down, removed, damaged or destroyed any trees, shrub or plant on Trust land or Trust works; or

(c) remove or cause to be removed any soil or rock from Trust land or trust works; or

(d) erect or construct or cause to be erected or constructed any booth, hut or other structure on Trust land or Trust works; or

(e) attach, fix or paint or cause to be attached, fixed or painted any bill, device, poster, sign or advertisement on any tree, building, fence, seat or other structure on or surrounding any Trust land or Trust works; or

(f) deposit or cause to be deposited in any river, stream or watercourse under the control or management of the Trust any trees, logs, rubbish, soil, carcase or any other materials calculated or likely to cause interference with the flow of water in, or silting up of, or injury to, or pollution of such river stream or watercourse.

6. No person shall obstruct, hinder or interfere with any officer, employee, servant, or agent of the Trust in the exercise or performance of his lawful duties.

7. No person shall remain on any Trust land or Trust works after having been directed to leave such land or works by any officer, employee, servant or agent of the Trust duly authorised in that regard, or by a member of the police force.

8. No person shall enter upon any Trust land or Trust works if a sign or notice erected upon such land or works indicates that such entry is prohibited.

9. Any person who is guilty of any wilful act or default contrary to any of the provisions of this By-Law shall be liable on conviction to a penalty of not more than \$40.00 and in the case of a continuation or repetition of that offence after a conviction or order of any court in relation to the offence a further penalty of not more than \$4.00 for each day on which the offence is so continued or repeated.

The foregoing By-Law was made by the Avon River Improvement Trust and the common seal of the said Trust was hereunto affixed, on the 3rd day of March, 1976, in the presence of—

J. M. NOBLE, Chairman.  
M. HIGGINS, Commissioner.  
ALAN L. CARR, Secretary.

(SEAL)

Approved by the Governor in Council on the 16th November, 1976.—TOM FORRISTAL, Clerk of the Executive Council. 6285

## GEELONG WATERWORKS AND SEWERAGE TRUST.

Pursuant to section 60 of the *Geelong Waterworks and Sewerage Act 1958* (No. 6263) the Trust has prepared plans to indicate the particulars of sewers and underground works, the construction of which the Trust intends to begin at a date, not less than one month after publication of the notices, in or adjacent to, the following localities within the Drainage Area.

Moruya Drive, Emmy Court, Polley Court, Kerger Court, Pannell Court and Hartwick Court. Grovedale, City of South Barwon.

Christies Road. Leopold, Shire of Bellarine.

Notice is hereby given that the plans indicated are open for public inspection at the Trust's Offices, 78 Moorabool Street, Geelong, between the hours of 9.00 a.m. and 5.00 p.m. from Monday to Friday (public holidays excepted) by the owners or occupiers of land or premises within the Drainage Area.

6287

B. C. HENSHAW, Secretary.

## CRANBOURNE SEWERAGE AUTHORITY.

CONSTRUCTION OF CRANBOURNE SEWERAGE SCHEME—  
STAGE 2.

Notice is hereby given that the Authority intends to commence construction of the Cranbourne Township Sewerage Scheme—Stage 2 during the month of February, 1977.

The area affected is that part of the Township north of Camms Road between the South Gippsland Highway and the railway line which is subdivided for residential purposes.

Plans of the Scheme including the location of sewers can be inspected at the Authority's Office in Sladen Street, Cranbourne between the hours of 9 a.m. to 5 p.m. Mondays to Fridays.

6197

T. VICKERMAN, Secretary.

## FRANKSTON SEWERAGE AUTHORITY.

DECLARATION OF SEWERED AREAS NOS. 134 TO 136  
INCLUSIVE.

That the Frankston Sewerage Authority, having made provision for carrying off sewage from each and every property, which or any part of which is within the sewerage areas hereinafter described, doth hereby declare that on and after the first day of February, 1977 each and every property, which or any part of which is within the said sewerage area, shall be deemed to be a seweraged property within the meaning of the said *Sewerage Districts Act 1958*.

The boundaries of the sewerage areas hereinbefore referred to are:—

## Area No. 134.

Comprising L.P. No. 112794 being Stage 5 of the Lake-wood Estate off Robinsons Road, South Frankston—114 vacant lots.

## Area No. 135.

Comprising an area consisting of Lot 1 L.P.21657 and Lot 2 L.P.74857 adjacent to declared area No. 103 East Seaford—1 vacant lot and Greenway Retirement Village.

## Area No. 136.

Consisting of the following properties in South Frankston—

*Camelot Court*.—Lot Nos. 9 to 14 inclusive on L.P. No. 90795.

*Canadian Bay Road*.—Lot No. 1 on L.P. No. 47032, Lot No. 2 on L.P. No. 112319, Lot No. 2 on L.P. No. 112320.

*Cummins Street*.—Lots 30 and 36 to 39 inclusive on survey plan No. S-2470.

*Hammersley Court*.—Lot Nos. 7 and 9 on L.P.81393.

*Lowe Street*.—Lot Nos. 11, 12 and 16 on survey plan No. S-2470, Lot Nos. 1 to 8 inclusive on L.P. No. 113858.

*Mackeith Court*.—Lot Nos. 7 and 8 on L.P. No. 84108.

*Mather Road*.—Lot No. 22 survey plan No. S-2470, Lot No. 1 on L.P. No. 82124, Lot Nos. 2 and 3 on L.P. No. 73567, Lot Nos. 1 to 6 inclusive on L.P. No. 86188, Lot Nos. 159 to 161 inclusive on L.P. No. 84756, Lot Nos. 1 to 4 L.P. No. 120025.

*Nepean Highway and Canadian Bay Road Corner*.—Part Lot No. 80 on L.P.1128 comprising an area of 6.07 hectares.

*Pennington Close*.—Lot Nos. 5 to 10 inclusive on L.P. No. 83930.

*Rylston Court*.—Lot Nos. 192 and 193 on L.P. No. 84755.

*Sunset Crescent*.—Lot 43 on L.P. No. 53646.

*Stradella Court*.—Lot 166 on L.P. No. 84756.

*Walkers Road*.—Lot Nos. 7 and 8 on L.P. 95607, Lot No. 27 on L.P. No. 81098, Lot No. 17 on L.P. No. 68076, Lot No. 2 on L.P. No. 83930, Education Department Property comprising an area of 6.4 hectares—32 houses, 31 vacant lots.

By order of the said Authority,

G. R. PEARSON, Chairman.  
ADRIAN BUTLER, Secretary.

6198

## LILYDALE SEWERAGE AUTHORITY

## TEMPORARY SEWERAGE TREATMENT PLANT

Notice is hereby given that for the purpose of sewerage the area in and around Wandin, a temporary sewerage treatment plant will be constructed in the following location:

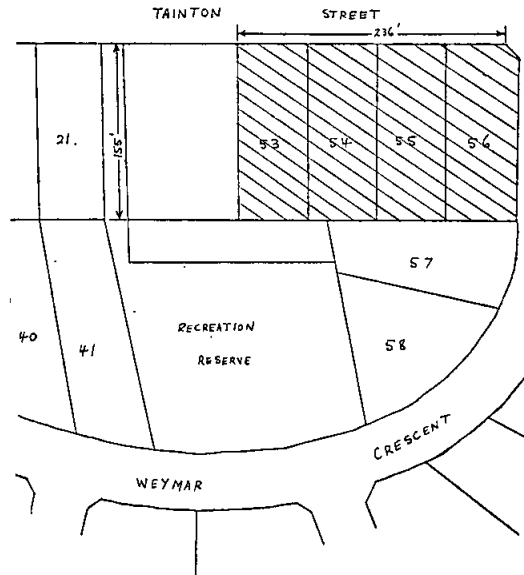

Further details may be obtained from the Authority Office, 197 Main Street, Lilydale.

6123

G. B. KOHLMAN, Secretary.

## TORQUAY SEWERAGE AUTHORITY.

## BY-LAW No. 4.

The Torquay Sewerage Authority, pursuant to and in exercise of the powers and authorities conferred upon it by the *Sewerage Districts Act 1958* and of any and every other power or authority in any wise enabling it in that behalf, doth hereby make the By-Law following:—

By-Law No. 1 is hereby amended as follows:—

1. In Sub-Clause (2) of Clause (a) of Section 9 for the expression Two Dollars (\$2) there shall be substituted Four Dollars (\$4).

2. In Clause (b) of Section 9, for sub-clauses (1), (2), (3), (4) and (5) there shall be substituted:—

- (1) For plan of design, a fee of Fourteen Dollars (\$14) plus Two Dollars (\$2) for each fitting.
- (2) For making and/or examining any alterations or additions to a plan previously issued or approved by the Engineer, a fee of Four Dollars (\$4) shall be made by the Authority for each fitting or drain altered or added.
- (3) For inspecting drains and testing by the Authority's inspector and preparation of records plans, a fee of Twelve Dollars (\$12) for each inspection.
- (4) For inspecting plumbing by the Authority's inspector, a fee of Twelve Dollars (\$12) for each ten (10) fittings or part of ten fittings in the installation, plus Six Dollars (\$6) for each additional inspection necessary owing to faulty work.
- (5) For general engineering supervision by the Authority's Engineer, a fee of Three Dollars and Fifty Cents (\$3.50) for each ten (10) fittings or part of ten fittings in the installation.

3. For Sub-Clauses (1), (3), (4), (5), (6) and (7) of Clause (c) of Section 9 there shall be substituted:—

- (1) For the supply of a block plan, a fee of Four Dollars (\$4). For tenements exceeding 4,000 square feet in ground floor area and/or properties exceeding 2 acres in extent, an additional fee of Four Dollars (\$4) shall be charged for each additional 4,000 square feet or part thereof and/or each additional 2 acres or part thereof.

- (3) For the examination of the owner's plan of design and specification, a fee of Eight Dollars (\$8) for each plan of from one to five fittings plus One Dollar and Fifty Cents (\$1.50) for each fitting over five.
- (4) For examining any alterations or additions to a plan previously issued or approved by the Engineer, a fee of Three Dollars (\$3) shall be made by the Authority for each fitting or drain altered or added.
- (5) For inspecting drains and testing by the Authority's inspector and preparation of records plans, a fee of Twelve Dollars (\$12) for each inspection.
- (6) For inspecting plumbing by the Authority's inspector, a fee of Twelve Dollars (\$12) for each ten (10) fittings or part of ten fittings in the installation plus Six Dollars (\$6) for each additional inspection necessary owing to faulty work.
- (7) For general engineering supervision by the Authority's Engineer, a fee of Three Dollars and Fifty Cents (\$3.50) for each ten (10) fittings or part of ten fittings in the installation.

The foregoing By-Law was made and passed by the Sewerage Authority on the Third day of November and confirmed on the 1st day of December, 1975.

In witness whereof the common seal of the Authority was affixed hereto, in the presence of—

(SEAL)                      HOWARD H. WILLIAMS, Chairman.  
 R. W. PETTITT, Member.  
 6245                          G. L. PEARCE, Secretary.

HERBERT TURNER & DAVIS.  
 Victoria.

APPLICATION FOR DISPOSAL OF LAND PURSUANT TO AN ACT TO PROVIDE FOR THE ABOLITION OF STATE AID TO RELIGION ACT 391.—FIRST SCHEDULE.

1. The Most Reverend Frank Woods of Cathedral Buildings, Flinders Lane, Melbourne, in the State of Victoria Archbishop of the Church of England Diocese of Melbourne head or authorised representative of the Denomination known as The Church of England in the Diocese of Melbourne in Victoria with the consent of The Church of England Trusts Corporation for the Diocese of Melbourne of Flinders Lane, Melbourne, aforesaid which is entitled to be registered as the Trustee of the land described in the subjoined Statement of Trusts hereby applies to the Governor of the State of Victoria for leave to dispose of the said land by the means and for the purposes mentioned in the said Statement of Trusts and I hereby certify that the said land was promised or reserved as a site for Church of England purposes on the 20th day of October One thousand eight hundred and fifty-five.

2. That the Church of England Trusts Corporation for the Diocese of Melbourne is entitled to be registered as the only Trustee of the said land.

3. There are no buildings erected upon the said land.

4. The only person entitled to administer in or occupy the said land is the Incumbent of the Parish of Sunbury namely the Reverend Donald Milton Shepherd, St. Mary's Vicarage, Sunbury.

Dated this 28th day of October, 1976.

Signed sealed and delivered by the said The Most Reverend Frank Woods in Victoria; signed.—FRANK WOODS.

The common seal of The Church of England Trusts Corporation for the Diocese of Melbourne was hereto affixed by authority of the Trustees:

Signed FRANK MELBOURNE.—Two of the Corporation's Trustees.  
 Signed WILLIAM FELTHAM.

STATEMENT OF TRUSTS.

*Description of the land.*—8 122 square metres, Township of the Gap, Parish of Buttlejork, County of Bourke, being Crown Allotment 61 Section 11. Commencing at the southern most angle of Crown Allotment 6 Section 11 bounded thence by Dundas Street bearing 230 deg. 30 min., 80.75 metres by Victoria Street bearing 320 deg. 30 min., 100.58 metres, by Hamilton Street bearing 50 deg. 30 min., 80.75 metres, and thence by Crown Allotment 6 bearing 140 deg. 30 min., 100.58 metres to the point of commencement.

*Name of Trustee.*—The Church of England Trusts Corporation for the Diocese of Melbourne of Cathedral Buildings, Flinders Lane, Melbourne.

*Power of Disposition.*—Power to sell lease Mortgage or exchange all or any part of such land subject to the approval of the Archbishop of Melbourne for the time being or during the absence of the Archbishop from the Diocese or the vacancy of the Secretary to the approval of the person for the time being administering the affairs thereof.

The land until otherwise disposed of to be held for the purposes for which it was granted or reserved by the Crown.

*Purposes to which Proceeds of Disposition are to be applied.*—To such purposes of the Church of England as may be agreed upon by—

- (i) The Bishop or during his absence from his See or during the vacancy thereof by the person or persons for the time being administering the affairs of the Diocese.
- (ii) The Trustees of the Church of England Trusts Corporation for the Diocese of Melbourne.
- (iii) The minister entitled to occupy the aforescribed land. 6322

Victoria.

ACT 391.—FIRST SCHEDULE.

I, Ronald William Allardice head or authorized representative of the denomination known as The Methodist Church of Australasia in Victoria with the consent of Methodist Church (Victoria) Property Trust trustees of the land described in the subjoined statement of trusts, and of Rev. G. W. Watson of 113 Koroit Street, Warrnambool being the person entitled to minister in or occupy a building or buildings upon the said land, hereby apply to the Governor of the State of Victoria for leave to dispose of the said land by the means and for the purposes mentioned in the said statement of trusts, and I hereby certify that the said land was promised or reserved by Order in Council on the 22nd day of July 1856, for the purpose of the Church.

That the only trustees of the said land resident in the State of Victoria are The Methodist Church (Victoria) Property Trust.

That the only buildings upon the said land are nil, and that the only persons entitled to minister in or occupy the same are the above-named Rev. G. W. Watson of 113 Koroit Street, Warrnambool.

Signature of authorised representative.—R. W. ALLARDICE.

We consent to this application—

The Common Seal of Methodist Church (Victoria) Property Trust was hereunto affixed pursuant to a resolution of the Trust in the presence of:

(SEAL)                      R. W. ALLARDICE, Member.  
 G. W. WATSON, Member.

STATEMENT OF TRUSTS.

*Description of Land.*—Site for Wesleyan Church purposes temporarily reserved by Order in Council of the 22nd July 1856. 4600 square metres, more or less. Township of Woodford, Parish of Purnim County of Villiers being Crown allotment 1A Section G. Commencing at the South-western angle of Crown allotment 3, Section G. bounded thence by Albert Street bearing 270 deg. 00 min. 40.23 metres; by Regent Street bearing 0 deg. 00 min. 124.72 metres; south-easterly by the Merri River to the western boundary of Crown allotment 3; and thence by that boundary bearing 180 deg. 00 min. 100.58 metres to the point of commencement.

*Names of Trustees.*—Methodist Church (Victoria) Property Trust.

*Powers of Disposition.*—Such powers of disposition, including powers of sale, lease or mortgage as are given to the Trust by the Methodist Church (Victoria) Property Trust Act No. 8007 of 1970.

*Purposes to which Proceeds of Disposition are to be applied.*—To such Methodist Church purposes as shall be approved by the Committee of the annual Conference of the Methodist Church of Australasia in Victoria. 6321

Take notice that Giuseppa Xalfa of 48 Harrison Street, Brunswick in the State of Victoria, on behalf of her infant daughter Patricia Elvira Quirino formerly called Patricia Elvira Fucks did by Deed Poll dated the 10th day of February, 1977, on behalf of Patricia Elvira Quirino change her name to Patricia Elvira Quirino.

6281

F. SAGARIA.



**NOTICE OF INTENTION TO APPLY FOR A LICENCE TO DIVERT WATER AND CUT RACE FROM THE BROKEN RIVER AT STEWARTON.**

We hereby give notice that we intend to apply for a Licence empowering us to divert water for a term of four years to the extent of 432 megalitres per annum at a maximum rate of 18 megalitres per day of 24 hours for the purpose of irrigating 72 ha. being part of Allotments 19, 21, 22, 6, Parish of Currawa, and to occupy certain Crown Lands for works of diversion, and to cut a race thereon.

Any objection to such application must be forwarded in writing to reach the State Rivers and Water Supply Commission, Melbourne before 12th March, 1977, being thirty days from the first publication of this Notice.

K. M. FELDTMANN.  
E. E. FELDTMANN.  
A. M. FELDTMANN.

"Roseleigh Park," Goorambat.

6206

Notice is hereby given that Bruno Developments (Vic.) Pty. Limited has applied for a lease pursuant to sections 134 and 135 of the Land Act 1958 for a term of 40 years in respect of allotment 8n, section 63b, City of Port Melbourne, containing 6273 square metres approximately as a site for general industrial purposes. 6080

Notice is hereby given that the partnership heretofore subsisting between Leopold Solomon Rosenthal, Serge Saubern and Robert John Heathcote carrying on business as solicitors at 140 William Street, Melbourne in the State of Victoria under the style or firm of Slonim Velik & Emanuel has been dissolved by mutual consent as from the 1st day of October, 1976 so far as concerns the said Robert John Heathcote who retires from the said firm. All debts due to and owing by the said firm will be received and paid respectively by Leopold Solomon Rosenthal and Serge Saubern who will continue to carry on the said business in partnership under the style or firm of Slonim Velik & Emanuel.

Dated this 7th day of February, 1977.

6186

**NOTICE OF DISSOLUTION OF PARTNERSHIP.**

Notice is hereby given that the partnership heretofore subsisting between Bianca Pty. Ltd. and Ditronics Pty. Ltd. and Digital Electronics Pty. Ltd., carrying on business as vendors of electronic equipment at 403 Tooronga Road, Hawthorn East has been dissolved by mutual consent, as from the 31st December, 1976.

BIANCA PTY. LTD.  
DITRONICS PTY. LTD.  
DIGITAL ELECTRONICS PTY. LTD.

Neville & Co., solicitors, 1401 Malvern Road, Malvern.

6190

Notice is hereby given that the Partnership heretofore existing between Keith Leonard Wight, Valerie Joy Wight, Jeffrey Sewell and Noel Patrick Walsh carrying on business as Garage and Service Station Operators in Matthews Avenue, Airport West in the State of Victoria in the style or firm name of Drome Auto Port Shell has been dissolved by mutual consent as from the 1st day of February 1977.

JAMES H. GAMBLE, solicitor, 70 Bulla Road, Strathmore. 6280

Take note that the partnership between Rodney Steele Augustine of Koornalla Crescent, Mount Eliza, and James Webb of Nepean Highway, Frankston, established for the purpose of carrying on a business as Builders and Designers, was dissolved on the 11th February, 1977, by mutual consent.

Also take note that the proprietorship of the said business of Builders and Designers, known and registered as S. Augustine Associates of 86 Mt. Eliza Way, Mt. Eliza, is now vested solely in the said James Webb of Nepean Highway, Frankston.

JAMES WEBB.  
RODNEY STEELE AUGUSTINE.  
6282

Notice is hereby given that the partnership heretofore subsisting between Tony Jacobus Van't Riet, Carole Anita Van't Riet, Barry James Percival Tebby and Susan Wendy Tebby carrying on business as bricklayers and builders at 20 Balmoral Street Kilsyth in the State of Victoria under the firm of Jet Bricklayers and Building Contractors has been dissolved as from the 31st March, 1976, so far as concerns the said Barry James Percival Tebby and Susan Wendy Tebby who retire from the said firm.

6213

PETER J. FRANCIS.

The partnership between Robert Issell and Kenneth Edward Raynor carrying on business under the names Pink Poodle Clipping Service and Tarbouka Enterprises at 17 Victoria Avenue, Albert Park and Ashbourne Road, Woodend has been dissolved as of the 9th of February 1977.

6214

D. MCGINNES.

Notice is hereby given that the Partnership heretofore subsisting between Raymond John Armstrong, Gloria Rose Armstrong and Ronald James Birkett carrying on business as builders at 1 Kelvin Avenue Sebastopol has been dissolved as from the 14th day of December, 1976 so far as concerns the said Ronald James Birkett who retires from the said partnership.

Dated this 10th day of February, 1977.

Signed for and on behalf of the partners by Messrs. Byrne Jones & Torney, solicitors, 38 Lydiard Street South, Ballarat. 6230

Notice is hereby given that the partnership heretofore subsisting between Thomas Doherty of 27 Halton Road, North Dandenong and Dino Bernado Santoni of 2 Devira Street, Dandenong carrying on business as Carpet and Furniture Retailers and Distributors at 266 Railway Parade, Noble Park under the style or firm of D.T.N.M. Home Furnishings has been dissolved as from the 4th day of February, 1977.

All debts due to and owing by the said firm will be received and paid respectively by Dino Bernado Santoni who will continue to carry on the said business in his own right under the style or firm name D.T.N.M. Home Furnishings from the same premises.

Dated this 4th day of February, 1977.

MACMILLAN SEGAL & LENTON, solicitors, of 239 Park Street South Melbourne, solicitors and agents for Thomas Doherty and Dino Bernado Santoni. 6247

In the matter of the Companies Act 1961; and in the matter of WOOL PROCESSORS PTY. LTD.

Notice is hereby given that pursuant to section 272 of the Act, the final meeting of the members of the above company will be held on the 8th floor Price Waterhouse & Co. on the Sixteenth day of March, 1977 for the purpose of the liquidator laying before the meeting an account of the winding up and the giving of any explanation thereof.

Dated this 9th day of February, 1977.

P. W. HARVEY, Liquidator.  
Price Waterhouse & Co., 447 Collins Street, Melbourne, 3000. 6314

Companies Act 1961.—In the matter of ROGERS JOINERY PROPRIETARY LIMITED (in Liquidation).—Notice of Meeting of Creditors, Pursuant to Section 261 (5).

Notice is hereby given that a meeting of the creditors of the abovenamed company will be held pursuant to Section 261 (5) of the Companies Act to appoint a liquidator of the company following the vacancy caused by the death of the former liquidator Mr. Lewis Luckins. The meeting will be held at the office of Lewis Luckins & Co. 3rd Floor, 470 Bourke Street, Melbourne, on Friday, 4th March, 1977, at 2.30 P.M.

Dated this 15th day of February, 1977.

MATHEWS TIMBER PTY. LTD.  
R. A. MCPHERSON.  
Lewis Luckins & Co., chartered accountants, 470 Bourke Street, Melbourne, 3000. Telephone 67 6944. 6315

Companies Act 1961.—In the matter of D. F. BRAUN & CO. PTY. LTD. (in Liquidation).—Notice of Meeting of Creditors, Pursuant to Section 261 (5).

Notice is hereby given that a meeting of the creditors of the abovenamed company will be held pursuant to Section 261 (5) of the Companies Act to appoint a liquidator of the company following the vacancy caused by the death of the former liquidator Mr. Lewis Luckins. The meeting will be held at the office of Lewis Luckins & Co. 3rd Floor, 470 Bourke Street, Melbourne, on Friday, 4th March, 1977, at 11.30 A.M.

Dated this 15th day of February, 1977.

BERNARD PAUL MARRIOTT & CO.,  
Deputy Commissioner of Taxation.  
Lewis Luckins & Co., chartered accountants, 470 Bourke Street, Melbourne, 3000. Telephone 67 6944. 6316

## Form 92.

In the matter of the Companies Act 1961, Section 206 (4); and in the matter of PASTORAL REVIEW PTY. LTD.—Notice of Meeting of Creditors.

Notice is hereby given that a meeting of the creditors of Pastoral Review Pty. Limited will be held at the offices of Hungerfords, 3rd Floor, 44 Market Street, Melbourne in the State of Victoria at 12.15 p.m. in the afternoon of the 1st day of March 1977.

*Agenda.*

1. That as the Official Manager of the company is of the opinion that the continuance of the Official Management of the company will not enable it to pay its debts the company should be wound up.

2. To appoint a Liquidator for the purpose of the winding up.

3. To fix the remuneration of the Liquidator.

4. To appoint a Committee of Inspection.

Dated this 14th day of February, 1977.

6313 A. B. PEARSON, Official Manager.

*The Companies Act 1961.*

W. CROSS & SONS PTY. LIMITED (IN LIQUIDATION).

Notice is hereby given that pursuant to Section 272 of the Companies Act 1961, a General Meeting of members of the Company will be held at the offices of Irish Young & Outhwaite, 23rd Floor AMP Tower, 535 Bourke Street, Melbourne on Thursday 24th March, 1977 at 2.30 o'clock in the afternoon for the purpose of having laid before them an account showing how the winding up has been conducted and the property of the Company disposed of and of hearing any explanation that may be given by the Liquidators.

Dated the 14th day of February, 1977.

J. K. BOYCE & A. S. HOME, Liquidators.

Irish Young & Outhwaite, 535 Bourke Street, Melbourne, Vic., 3000. 6317

*The Companies Act 1961.*

M. W. PRICE PROPRIETARY LIMITED (IN LIQUIDATION).

Notice is hereby given that pursuant to Section 272 of the Companies Act 1961, a General Meeting of members of the Company will be held at the offices of Irish Young & Outhwaite, 23rd Floor AMP Tower, 535 Bourke Street, Melbourne on Thursday 24th March, 1977 at 2.30 o'clock in the afternoon for the purpose of having laid before them an account showing how the winding up has been conducted and the property of the Company disposed of and of hearing any explanation that may be given by the Liquidators.

Dated the 14th day of February, 1977.

J. K. BOYCE & A. S. HOME, Liquidators.

Irish Young & Outhwaite, 535 Bourke Street, Melbourne, Vic., 3000. 6318

SMITHS GIFT STORE PTY. LTD. (IN VOLUNTARY LIQUIDATION).

Notice is hereby given in pursuance of Section 272 (2) of the Companies Act 1961, that the final meeting of members of the abovenamed company will be held at 4 Powerham Road, Caulfield, at 8.00 p.m. on 18th March, 1977, for the purpose of presenting the final accounts of the liquidation showing the manner in which the winding up has been conducted by the liquidator.

Dated this 8th day of February, 1977.

6193 MAURICE SMITH, Liquidator.

*The Companies Act 1961.*

A. T. & S. A. CO. PROPRIETARY LIMITED (IN LIQUIDATION).

Notice is hereby given that pursuant to Section 272 of the Companies Act 1961, a General Meeting of members of the Company will be held at the offices of Irish Young & Outhwaite, 23rd Floor AMP Tower, 535 Bourke Street, Melbourne on Thursday 24th March, 1977 at 2.30 o'clock in the afternoon for the purpose of having laid before them an account showing how the winding up has been conducted and the property of the Company disposed of and of hearing any explanation that may be given by the Liquidators.

Dated the 14th day of February, 1977.

J. K. BOYCE & A. S. HOME, Liquidators.

Irish Young & Outhwaite, 535 Bourke Street, Melbourne, Vic., 3000. 6319

OVAL INVESTMENTS PTY. LTD. (IN VOLUNTARY LIQUIDATION).

Notice is hereby given in pursuance of Section 272 (2) of the Companies Act 1961, that the final meeting of members of the abovenamed company will be held at 650 Nepean Highway, Frankston, at 7.00 p.m. on 18th March, 1977, for the purpose of presenting the final accounts of the liquidation showing the manner in which the winding up has been conducted by the liquidator.

Dated this 8th day of February, 1977.

6194 D. F. GORDON, Liquidator.

*The Companies Act 1961.*

SHIPPING CONTAINER SERVICES PTY. LIMITED (IN LIQUIDATION).

Notice is hereby given that pursuant to Section 272 of the Companies Act 1961, a General Meeting of members of the Company will be held at the offices of Irish Young & Outhwaite, 23rd Floor AMP Tower, 535 Bourke Street, Melbourne on Thursday 24th March, 1977 at 2.30 o'clock in the afternoon for the purpose of having laid before them an account showing how the winding up has been conducted and the property of the Company disposed of and of hearing any explanation that may be given by the Liquidators.

Dated the 14th day of February, 1977.

J. K. BOYCE & A. S. HOME, Liquidators.

Irish Young & Outhwaite, 535 Bourke Street, Melbourne, Vic., 3000. 6320

Notice is hereby given that at a meeting of members of Hames and Woodward Proprietary Limited held at 27 Armstrong Street North, Ballarat, on 7th February, 1977 the following Resolution was passed as a Special Resolution:—

"That the company be wound up voluntarily."

Dated at Ballarat, this 7th day of February, 1977.

6192 B. K. METCALFE, Liquidator.

WIGMORE PTY. LTD (IN VOLUNTARY LIQUIDATION).

Notice is hereby given in pursuance of Section 272 (2) of the Companies Act 1961, the final meeting of members of the abovenamed company will be held at "Tree Tops", Jacksons Road, Mt. Eliza, at 8.00 p.m. on 18th March, 1977, for the purpose of presenting the final accounts of the liquidation showing the manner in which the winding up has been conducted by the liquidator.

Dated this 8th day of February, 1977.

6195 J. F. ROBERTSON, Liquidator.

DRYBURGH INVESTMENTS PTY. LIMITED (IN VOLUNTARY LIQUIDATION).

*NOTICE OF GENERAL MEETING.*

Notice is hereby given that a General Meeting of the members of the company in pursuance of Section 272 of the Companies Act will be held at Level 30, Tower Building, Australia Square, Sydney, at 10 a.m., on 21st March, 1977 for the purposes of:—

1. Having an account showing how the winding up has been conducted and the property of the company disposed of laid before them.

2. Hearing any explanation given by the liquidator.

3. Determining by resolution the manner in which the books and papers of the company shall be disposed of.

Dated at Sydney, this 7th day of February, 1977.

6196 D. A. CRAWFORD, Liquidator.

*Companies Act 1961.*

C.I.S. INVESTMENTS PTY. LTD. (IN VOLUNTARY LIQUIDATION).

*NOTICE OF FINAL MEETING.*

Notice is hereby given pursuant to section 272 of the Companies Act 1961, that the final meeting of the members of the abovenamed company will be held at the office of William Buck & Co., 21 Burwood Road, Hawthorn, on the 22nd day of March, 1977 at 10.30 a.m. in the forenoon for the purpose of laying before the meeting an account showing how the winding up has been conducted and the property of the company disposed of, and hearing any explanations that may be given by the liquidator; and to pass a special resolution to destroy the company's books and papers, pursuant to section 284 (3) (b) of the Companies Act 1961.

Dated the 10th day of February, 1977.

6215 C. I. SHUGG, Liquidator.

**POSITANO INVESTMENTS PROPRIETARY LIMITED (IN VOLUNTARY LIQUIDATION).**

Notice is hereby given that pursuant to section 272 (2) of the *Companies Act 1961* that a General Meeting of the members of the abovenamed company will be held at 29 Alma Road, St. Kilda, at 9 a.m. in the forenoon on the 23rd March, 1977, for the purpose of having an account laid before them showing the manner in which the winding up has been conducted and the property of the company disposed of and of hearing any explanation that may be given by the liquidator.

K. E. LIPPMANN, Liquidator.

R. Lowe, Lippmann, Figdor & Franck. 6216

**Companies Act 1961.—In the matter of MONACO AUTOS PTY. LTD. (in Liquidation).**

Notice is hereby given that at an extraordinary meeting of the members of the abovenamed company held on the 10th February, 1977 it was resolved that the company be wound up voluntarily and at a meeting of creditors held on the same day pursuant to section 260, it was resolved that for such purpose Everett Thomson Bent of Suite 18, 545 St. Kilda Road, Melbourne, Public Accountant, be appointed liquidator.

Notice is also given that after 21 days from this date I shall proceed to distribute the assets. All creditors having any claims against the company should furnish particulars of same by that date, otherwise I shall proceed to distribute the assets without regard to their claim.

Dated this 10th day of February, 1977.

E. T. BENT, Liquidator.

Bent & Cogle, public accountants, Suite 18, 545 St. Kilda Road, Melbourne, 3004. 6226

**In the Supreme Court of Victoria.—1977 Co. 9643.—In the matter of the Companies Act 1961; and in the matter of LES RAMSEY (FIBREGLASS) PTY. LIMITED.**

Notice is hereby given that a petition for the winding up of the abovenamed Company by the Supreme Court was on the 2nd day of February 1977 presented by Leo Thomas FitzGerald, Deputy Commissioner of Taxation of the Commonwealth of Australia and that the said petition is directed to be heard before the Court sitting at the Fourteenth Court, Law Courts, William Street, Melbourne at the hour of 10.30 o'clock in the forenoon on the 22nd day of March 1977 and any creditor or contributory of the said company desiring to support or oppose the making of an order on the said petition may appear at the time of hearing by himself or his Counsel for the purpose; and a copy of the said petition will be furnished to any creditor or contributory of the said company requiring the same by the undersigned on payment of the regulated charge for the same.

The Petitioner's official address is 350 Collins Street, Melbourne.

The Petitioner's Solicitor is Alan R. Neaves, Crown Solicitor for the Commonwealth of 99 Queen Street, Melbourne.

ALAN R. NEAVES.

NOTE.—Any person who intends to appear on the hearing of the said petition must serve on or send by post to the abovenamed Alan R. Neaves, notice in writing of his intention so to do. The notice must state the name and address of the person, or, if a firm, the name and address of the firm, and must be signed by the person or firm, or his, or their solicitor (if any), and must be served or, if posted, must be sent by post in sufficient time to reach the abovenamed not later than 4 o'clock in the afternoon of the 21st day of March, 1977. 6310

**In the Supreme Court of Victoria.—1977 Co. 9641.—In the matter of the Companies Act 1961; and in the matter of G. A. PETTY (AUTOMOTIVE) PROPRIETARY LIMITED.**

Notice is hereby given that a petition for the winding up of the abovenamed Company by the Supreme Court was on the 2nd day of February 1977 presented by Leo Thomas FitzGerald, Deputy Commissioner of Taxation of the Commonwealth of Australia and that the said petition is directed to be heard before the Court sitting at the Fourteenth Court, Law Courts, William Street, Melbourne at the hour of 10.30 o'clock in the forenoon on the 22nd day of March 1977 and any creditor or contributory of the said company desiring to support or oppose the making of an order on the said petition may appear at the time of hearing by himself or his Counsel for the purpose; and a copy of the said petition will be furnished to any creditor or contributory of the said company requiring the same by the undersigned on payment of the regulated charge for the same.

The Petitioner's official address is 350 Collins Street, Melbourne.

The Petitioner's Solicitor is Alan R. Neaves, Crown Solicitor for the Commonwealth of 99 Queen Street, Melbourne.

ALAN R. NEAVES.

NOTE.—Any person who intends to appear on the hearing of the said petition must serve on or send by post to the abovenamed Alan R. Neaves, notice in writing of his intention so to do. The notice must state the name and address of the person, or, if a firm, the name and address of the firm, and must be signed by the person or firm, or his, or their solicitor (if any), and must be served or, if posted, must be sent by post in sufficient time to reach the abovenamed not later than 4 o'clock in the afternoon of the 21st day of March, 1977. 6311

**In the Supreme Court of Victoria.—1977 Co. 9630.—In the matter of the Companies Act 1961; and in the matter of CHRISTINA CONTOURING PTY. LIMITED.**

Notice is hereby given that a petition for the winding up of the abovenamed Company by the Supreme Court was on the 25th day of January 1977 presented by Leo Thomas FitzGerald, Deputy Commissioner of Taxation of the Commonwealth of Australia and that the said petition is directed to be heard before the Court sitting at the Fourteenth Court, Law Courts, William Street, Melbourne at the hour of 10.30 o'clock in the forenoon on the 8th day of March 1977 and any creditor or contributory of the said company desiring to support or oppose the making of an order on the said petition may appear at the time of hearing by himself or his Counsel for the purpose; and a copy of the said petition will be furnished to any creditor or contributory of the said company requiring the same by the undersigned on payment of the regulated charge for the same.

The Petitioner's official address is 350 Collins Street, Melbourne.

The Petitioner's Solicitor is Alan R. Neaves, Crown Solicitor for the Commonwealth of 99 Queen Street, Melbourne.

ALAN R. NEAVES.

NOTE.—Any person who intends to appear on the hearing of the said petition must serve on or send by post to the abovenamed Alan R. Neaves, notice in writing of his intention so to do. The notice must state the name and address of the person, or, if a firm, the name and address of the firm, and must be signed by the person or firm, or his, or their solicitor (if any), and must be served or, if posted, must be sent by post in sufficient time to reach the abovenamed not later than 4 o'clock in the afternoon of the 7th day of March, 1977. 6308

**In the Supreme Court of Victoria.—1977 Co. 9631.—In the matter of the Companies Act 1961; and in the matter of GIPPSLAND ROAD AND BRIDGE PTY. LTD.**

Notice is hereby given that a petition for the winding up of the abovenamed Company by the Supreme Court was on the 25th day of January 1977 presented by Leo Thomas FitzGerald, Deputy Commissioner of Taxation of the Commonwealth of Australia and that the said petition is directed to be heard before the Court sitting at the Fourteenth Court, Law Courts, William Street, Melbourne at the hour of 10.30 o'clock in the forenoon on the 8th day of March 1977 and any creditor or contributory of the said company desiring to support or oppose the making of an order on the said petition may appear at the time of hearing by himself or his Counsel for the purpose; and a copy of the said petition will be furnished to any creditor or contributory of the said company requiring the same by the undersigned on payment of the regulated charge for the same.

The Petitioner's official address is 350 Collins Street, Melbourne.

The Petitioner's Solicitor is Alan R. Neaves, Crown Solicitor for the Commonwealth of 99 Queen Street, Melbourne.

ALAN R. NEAVES.

NOTE.—Any person who intends to appear on the hearing of the said petition must serve on or send by post to the abovenamed Alan R. Neaves, notice in writing of his intention so to do. The notice must state the name and address of the person, or, if a firm, the name and address of the firm, and must be signed by the person or firm, or his, or their solicitor (if any), and must be served or, if posted, must be sent by post in sufficient time to reach the abovenamed not later than 4 o'clock in the afternoon of the 7th day of March, 1977. 6312

In the Supreme Court of Victoria.—1977 Co. 6944.—In the matter of the *Companies Act 1961*; and in the matter of N. J. STIBBARD AND SONS PTY. LIMITED.

Notice is hereby given that a petition for the winding up of the abovenamed Company by the Supreme Court was on the 2nd day of February 1977 presented by Leo Thomas FitzGerald, Deputy Commissioner of Taxation of the Commonwealth of Australia and that the said petition is directed to be heard before the Court sitting at the Fourteenth Court, Law Courts, William Street, Melbourne at the hour of 10.30 o'clock in the forenoon on the 22nd day of March 1977 and any creditor or contributory of the said company desiring to support or oppose the making of an order on the said petition may appear at the time of hearing by himself or his Counsel for the purpose; and a copy of the said petition will be furnished to any creditor or contributory of the said company requiring the same by the undersigned on payment of the regulated charge for the same.

The Petitioner's official address is 350 Collins Street, Melbourne.

The Petitioner's Solicitor is Alan R. Neaves, Crown Solicitor for the Commonwealth of 99 Queen Street, Melbourne.

ALAN R. NEAVES.

NOTE.—Any person who intends to appear on the hearing of the said petition must serve on or send by post to the abovenamed Alan R. Neaves, notice in writing of his intention so to do. The notice must state the name and address of the person, or, if a firm, the name and address of the firm, and must be signed by the person or firm, or his, or their solicitor (if any), and must be served or, if posted, must be sent by post in sufficient time to reach the abovenamed not later than 4 o'clock in the afternoon of the 21st day of March, 1977. 6305

In the Supreme Court of Victoria.—1977 Co. 9645.—In the matter of the *Companies Act 1961*; and in the matter of SOUND AND FILM ENTERPRISES OF AUSTRALIA PTY. LIMITED.

Notice is hereby given that a petition for the winding up of the abovenamed Company by the Supreme Court was on the 2nd day of February 1977 presented by Leo Thomas FitzGerald, Deputy Commissioner of Taxation of the Commonwealth of Australia and that the said petition is directed to be heard before the Court sitting at the Fourteenth Court, Law Courts, William Street, Melbourne at the hour of 10.30 o'clock in the forenoon on the 22nd day of March 1977 and any creditor or contributory of the said company desiring to support or oppose the making of an order on the said petition may appear at the time of hearing by himself or his Counsel for the purpose; and a copy of the said petition will be furnished to any creditor or contributory of the said company requiring the same by the undersigned on payment of the regulated charge for the same.

The Petitioner's official address is 350 Collins Street, Melbourne.

The Petitioner's Solicitor is Alan R. Neaves, Crown Solicitor for the Commonwealth of 99 Queen Street, Melbourne.

ALAN R. NEAVES.

NOTE.—Any person who intends to appear on the hearing of the said petition must serve on or send by post to the abovenamed Alan R. Neaves, notice in writing of his intention so to do. The notice must state the name and address of the person, or, if a firm, the name and address of the firm, and must be signed by the person or firm, or his, or their solicitor (if any), and must be served or, if posted, must be sent by post in sufficient time to reach the abovenamed not later than 4 o'clock in the afternoon of the 21st day of March, 1977. 6306

In the Supreme Court of Victoria.—1977 Co. 9640.—In the matter of the *Companies Act 1961*; and in the matter of BRUCE BRETHERTON (WHOLESALE) PROPRIETARY LIMITED.

Notice is hereby given that a petition for the winding up of the abovenamed Company by the Supreme Court was on the 2nd day of February 1977 presented by Leo Thomas FitzGerald, Deputy Commissioner of Taxation of the Commonwealth of Australia and that the said petition is directed to be heard before the Court sitting at the Fourteenth Court, Law Courts, William Street, Melbourne at the hour of 10.30 o'clock in the forenoon on the 22nd day of March 1977 and any creditor or contributory of the said company desiring to support or oppose the making of an order on the said petition may appear at the time of hearing by himself or his Counsel for the purpose; and a copy of the said petition will be furnished

to any creditor or contributory of the said company requiring the same by the undersigned on payment of the regulated charge for the same.

The Petitioner's official address is 350 Collins Street, Melbourne.

The Petitioner's Solicitor is Alan R. Neaves, Crown Solicitor for the Commonwealth of 99 Queen Street, Melbourne.

ALAN R. NEAVES.

NOTE.—Any person who intends to appear on the hearing of the said petition must serve on or send by post to the abovenamed Alan R. Neaves, notice in writing of his intention so to do. The notice must state the name and address of the person, or, if a firm, the name and address of the firm, and must be signed by the person or firm, or his, or their solicitor (if any), and must be served or, if posted, must be sent by post in sufficient time to reach the abovenamed not later than 4 o'clock in the afternoon of the 21st day of March, 1977. 6307

In the Supreme Court of Victoria.—1977 Co. 9642.—In the matter of the *Companies Act 1961*; and in the matter of IMPORT TIMBERS PTY. LTD.

Notice is hereby given that a petition for the winding up of the abovenamed Company by the Supreme Court was on the 2nd day of February 1977 presented by Leo Thomas FitzGerald, Deputy Commissioner of Taxation of the Commonwealth of Australia and that the said petition is directed to be heard before the Court sitting at the Fourteenth Court, Law Courts, William Street, Melbourne at the hour of 10.30 o'clock in the forenoon on the 22nd day of March 1977 and any creditor or contributory of the said company desiring to support or oppose the making of an order on the said petition may appear at the time of hearing by himself or his Counsel for the purpose; and a copy of the said petition will be furnished to any creditor or contributory of the said company requiring the same by the undersigned on payment of the regulated charge for the same.

The Petitioner's official address is 350 Collins Street, Melbourne.

The Petitioner's Solicitor is Alan R. Neaves, Crown Solicitor for the Commonwealth of 99 Queen Street, Melbourne.

ALAN R. NEAVES.

NOTE.—Any person who intends to appear on the hearing of the said petition must serve on or send by post to the abovenamed Alan R. Neaves, notice in writing of his intention so to do. The notice must state the name and address of the person, or, if a firm, the name and address of the firm, and must be signed by the person or firm, or his, or their solicitor (if any), and must be served or, if posted, must be sent by post in sufficient time to reach the abovenamed not later than 4 o'clock in the afternoon of the 21st day of March, 1977. 6309

*Companies Act 1961.*

S. & G. KOSKY (EAST) PTY. LTD.

Notice is hereby given that pursuant to Section 272 of the *Companies Act 1961* a final meeting will be held of the Members and Creditors of the Company at 5 Korowa Street West Sunshine on the 24th day of March, 1977 at 11.00 a.m. for the purpose of laying before the Meeting an account for the winding up and any explanations thereof.

Dated this 10th day of February, 1977.

COLIN ALLAN KENNEDY, liquidator, of S. & G. Kosky (East) Pty. Ltd. 6292

*Companies Act 1961.*

S. & G. KOSKY (WEST) PTY. LTD.

Notice is hereby given that pursuant to Section 272 of the *Companies Act 1961* a final meeting will be held of the Members and Creditors of the Company at 5 Korowa Street West Sunshine on the 24th day of March, 1977 at 11.00 a.m. for the purpose of laying before the Meeting an account for the winding up and any explanations thereof.

Dated this 10th day of February, 1977.

COLIN ALLAN KENNEDY, liquidator, of the company, S. & G. Kosky (West) Pty. Ltd. 6293

*Companies Act 1961, Section 272.*  
**NAS (INVESTMENTS) PTY. LTD. (IN VOLUNTARY LIQUIDATION).**

**NOTICE OF FINAL MEETING OF MEMBERS.**

Notice is hereby given that a final meeting of members of NAS (Investments) Pty. Ltd. will be held on 14th March, 1977, at the office of Davey, Garcia & Co., 350 Latrobe Street, Melbourne, at 10 o'clock in the forenoon.

*Agenda.*

1. Presentation by the liquidator of an account showing how the winding up has been conducted and the property of the company has been disposed of and to give any explanation of the account.

2. The meeting to consider the following resolution:

"That immediately after the dissolution of the company the liquidator may destroy the books and papers of the company pursuant to section 284 of the Act."

Dated this 11th day of February, 1977.

6283 G. A. McRAE, Liquidator.

Form 92.

*Companies Act 1961 (as amended), Victoria, Section 272 Regulations 28 (2) (b) and 46 (2).*

**A. & S. RUFFY PROPRIETARY LIMITED.**

**NOTICE OF MEETING OF CREDITORS OR CONTRIBUTORIES.**

Notice is hereby given that a Meeting of the Contributories of A. & S. Ruffy Pty. Ltd. will be held at the office of C. G. Landy & Company, 7th floor, 37-41 Queen Street, Melbourne on the 16th day of March, 1977 at 9.30 o'clock in the forenoon.

*Agenda.*

To lay before the meeting the liquidators account showing how the winding up has been conducted and the property of the company has been disposed of.

Dated this 16th day of February, 1977.

6263 DONALD ALBERT CONABERE, Liquidator.

*Companies Act 1961, Section 254 (2) (b).*  
**SPERWAY CONSTRUCTIONS (MELBOURNE) PTY. LTD.**

Notice is hereby given that at an Extraordinary General Meeting of the Members of the abovenamed company held on the 10th day of February, 1977, it was resolved that the company be wound up voluntarily and that Alex Neville Bird and Michael John Hunter Davies, Chartered Accountants, of 289 Flinders Lane, Melbourne, be appointed joint Liquidators.

Notice is also given that after twenty-one days from this date we shall proceed to distribute the assets. All creditors having any claim against the company should furnish particulars of same by that date, otherwise we shall proceed to distribute the assets without regard to their claim.

Dated this 16th day of February, 1977.

A. N. BIRD,  
 M. J. H. DAVIES,  
 Joint Liquidators.

Neville Bird, Davies & Co., chartered accountants, 289 Flinders Lane, Melbourne. Telephone 63 2874. 6301

The *Companies Act 1961*.—In the matter of **NIBRON PRODUCTS PTY. LTD. (in Liquidation).**

Notice is hereby given that an Extraordinary General Meeting of the Members of the abovenamed company held on the 10th day of February, 1977 it was resolved that the company be wound up voluntarily, and at a meeting of creditors held on the same day pursuant to section 260 it was resolved that for such purpose John Martin Walsh, Accountant and Alan Murray Horsburgh, Chartered Accountant of 499 St. Kilda Road, Melbourne, be appointed joint and several Liquidators.

Notice is also given that after twenty-one days from this date we shall proceed to distribute the assets. All creditors having any claims against the company should furnish particulars of same by that date, otherwise we shall proceed to distribute the assets without regard to their claim.

Dated this 16th day of February, 1977.

J. M. WALSH & A. M. HORSBURGH, Liquidators.

Wallace, McMullin & Small, chartered accountants.

6302

In the Supreme Court of Victoria.—1976 Co. 9448.—In the matter of the *Companies Act 1961*; and in the matter of **MAKE INDUSTRIES PTY. LIMITED.—Notice of Winding Up Order.**

Winding-Up Order: Made 11th February 1977.

Name and Address of Liquidator: Alan Murray Horsburgh, 499 St. Kilda Road, Melbourne.

ALAN R. NEAVES, Crown Solicitor for the Commonwealth and Solicitor for the Petitioner. 6304

The *Companies Act 1961*.

**SECOND SKIN PTY. LIMITED (IN LIQUIDATION).**

**NOTICE OF FINAL MEETING OF CREDITORS.**

Notice is hereby given that the final meeting of the creditors and contributories of Second Skin Pty. Limited will be held at 51 Elgin Street, Carlton on the 22nd day of March, 1977 at 10.00 a.m., for the purpose of laying before the meeting the Liquidator's account of the winding up of the Company and the giving of any explanation thereof.

14th February, 1977.

6187 P. J. MORAN, Liquidator.

In the Supreme Court of Victoria.—1977 No. Co. 9367.—In the matter of the *Companies Act 1961*; and in the matter of **LANE & ROUX PTY. LIMITED.**

Notice is hereby given that a Petition for winding up of the abovenamed Company by the Supreme Court was on the 27th day of January, 1977 presented by Middendorp Electric Co. (Vic.) Pty. Limited and that the same Petition is directed to be heard before the Court sitting at the Law Courts Melbourne at the hour of 10.30 o'clock in the forenoon on the 11th day of March, 1977 and any creditor or contributory of the Company desiring to support or oppose the making of an order on the said petition may appear at the time of the hearing by himself or his Counsel for that purpose and a copy of the petition will be furnished to any creditor or contributory of that said company requiring the same by the undersigned on payment of the regulated charge of the same.

The Petitioner's address is 520 La Trobe Street, Melbourne.

The Petitioner's solicitors are H. S. Wise, Gershov & Co. of 343 Little Collins Street, Melbourne.

**NOTE.**—Any person who intends to appear on the hearing of the said petition must serve on or send by post to the abovenamed Solicitors notice in writing of his intention so to do. The Notice must state the name and address of the person or if a firm, the name and address of the firm and must be signed by the person or firm or his or their solicitor (if any) and must be served or if posted, must be sent by post in sufficient time to reach the abovenamed not later than four o'clock in the afternoon on the 10th day of March, 1977. 6188

*Companies Act 1961, Section 206 (4).*

**McMILLANS OF GIPPSLAND PTY. LTD.**

**OFFICIAL MANAGER APPOINTED.**

Notice is hereby given that a meeting of Creditors of McMillans of Gippsland Pty. Ltd., Official Manager Appointed will be held at Accountants House, 49 Exhibition Street, Melbourne at 10.00 a.m. on Friday 18th February, 1977, the company having convened a meeting of its members for the same day for the purpose of considering a resolution that the company be wound up voluntarily.

Dated this 9th day of February, 1977.

MICHAEL DAVID BURKE, Official Manager.

A partner in the firm of Michael Burke, Bond & Co., 26 Mason Street, Dandenong. 6191

*Companies Act 1961.*

**SMITHS FACTORS PTY. LIMITED (IN VOLUNTARY LIQUIDATION).**

Notice is hereby given in pursuance of Section 272 of the *Companies Act 1961* that a general meeting of the members of the abovenamed Company will be held at 267 Collins Street, Melbourne on the 21st day of March, 1977 at 10 a.m. in the forenoon for the purpose of having an account laid before them showing the manner in which the winding up has been conducted and the property of the Company disposed of and of hearing any explanation that may be given by the Liquidator.

Dated the 14th day of February, 1977.

6328 B. J. CHARNLEY, Liquidator.

## Unclaimed Moneys Act 1962.

## Register of Unclaimed Moneys held by the—

Name of Owner on Books and Last Known Address.	Total Amount Due to Owner.	Description of Unclaimed Moneys.	Date when Amount first became Payable.
§			
THE SHELL COMPANY OF AUSTRALIA LTD.			
Padamarous, Mr., Glenferrie	23.80	Credit Refund	—3.75
Hill, H.R., and Sons Pty. Ltd., 350 King Street, Melbourne	26.81	" "	—3.75
Colston, R. J., Mulgrave	14.71	" "	—3.75
Murray, E. P., and Sons, P.O. Box 55, Altona	28.35	" "	—5.75
Wilson, E. and B., 153 Newcombe Street, Portarlington	70.95	" "	—5.75
Smoglian, J., 6 Kent Street, Clifton Hill	12.00	" "	—6.75
Huffer, L., Bacchus Marsh	10.00	" "	—9.75
Williams, P. R., Mt. Eliza	14.68	" "	—9.75
Thompson, B., Olinda	11.99	" "	—10.75
Fordham, M. and R., Springvale South	12.45	" "	—11.75
Vella, E. C., 26 Westminster Drive, Avondale Heights	53.38	" "	—12.75
Hamman and Sons	30.10	" "	—12.75

6181

## The Companies Act 1961.

## F. COLLINS TRANSPORT SERVICE PROPRIETARY LIMITED (IN LIQUIDATION).

NOTICE CONVENING FINAL MEETING OF MEMBERS AND CREDITORS, PURSUANT TO SECTION 272.

Notice is hereby given pursuant to Section 272 of the Companies Act 1961, that a General Meeting of the members and creditors of the abovenamed company will be held in the offices of Wallace, McMullin & Smail, 499 St. Kilda Road, Melbourne, 3004, on Wednesday the sixteenth day of March, 1977, at 10.30 a.m. for the purpose of having an account laid before them showing the manner in which the winding up has been conducted and the property of the company disposed of and of hearing any explanations that may be given by the Liquidator.

Dated this tenth day of February, 1977.

6267 R. E. RAMSAY, Liquidator.

## Companies Act 1961.

## PROVO PROPERTIES PTY. LTD. (IN LIQUIDATION).

NOTICE OF INTENTION TO DECLARE A DIVIDEND TO PREFERENTIAL CREDITORS.

Notice is hereby given that, as liquidators of the abovenamed company we, Douglas Ewart Tonkin and Bruce Pescod, Chartered Accountants of Marquand & Co., 51 Queen Street, Melbourne intend to declare a First and Final Dividend to Preferential Creditors in this matter.

Preferential creditors must prove their debts by 14th March, 1977.

Dated at Melbourne, this 8th day of February, 1977.

D. E. TONKIN, Joint Liquidator.

Marquand & Co., 51 Queen Street, Melbourne, Vic. 6268  
3000.

## NOTICE OF MEETING.

Notice is hereby given that the liquidators final meeting of Jimarg Pty. Ltd. (In Voluntary Liquidation) for the purpose of considering the liquidator's Statement as to how the liquidation has been conducted, and the Company's assets disposed of, and such other matters as permitted by law, will be held at the office of John H. Donegan, 1st Floor, 390 Lonsdale Street, Melbourne on 16th March, 1977 at 3.00 p.m.

6269

JOHN H. DONEGAN, Liquidator.

In the matter of the Companies Act 1961; and in the matter of BACHUS PTY. LIMITED (in Voluntary Liquidation).—Notice of Final Meeting of Members, Pursuant to Section 272.

Notice is hereby given in pursuance of Section 272 of the Companies Act 1961 that a General Meeting of the members of the Company will be held at 46 Lansell Road, Toorak on the 16th day of March, 1977, at 10.00 o'clock in the forenoon for the purpose of having an account laid before it showing the manner in which the winding up has been conducted and the property of the company disposed of, and hearing any explanation that may be given by the liquidator.

Dated this 15th day of February, 1977.

6270 B. SKILLBECK, Liquidator.

## Companies Act 1961.

## ECNEL PROPRIETARY LIMITED (IN VOLUNTARY LIQUIDATION).

Notice is hereby given in pursuance of Section 272 of the Companies Act 1961 that a general meeting of the members of the abovenamed Company will be held at 16 Ivan Avenue, Edithvale on the 16th day of March, 1977 at 2 p.m. in the afternoon for the purpose of having an account laid before them showing the manner in which the winding up has been conducted and the property of the Company disposed of and of hearing any explanation that may be given by the Liquidator.

Dated the 10th day of February, 1977.

6229 T. L. PHELAN, Liquidator.

## Companies Act 1961.

## S. E. &amp; E. B. PTY. LTD. (IN LIQUIDATION).

Notice is hereby given that at an adjourned extraordinary general meeting of members of the abovenamed company held on the ninth of February 1977 it was resolved that the company be wound up voluntarily and that for such purpose Victor Raymond Dye, Chartered Accountant, 447 Collins Street Melbourne be appointed liquidator.

Notice is also given that after twenty-one days from this date I shall proceed to distribute the assets of the Company. All creditors who have any claim against the company should furnish particulars of same by that date, otherwise I shall proceed to distribute the assets without regard to their claim.

Dated this 11th day of February, 1977.

V. R. DYE, Liquidator.

Price, Waterhouse & Co., 447 Collins Street, Melbourne. 6303

## Companies Act 1961.

## TOPMAKERS PROPRIETARY LIMITED (IN VOLUNTARY LIQUIDATION).

Notice is hereby given that at an adjourned extraordinary general meeting of members of the abovenamed company held on 10th February 1977, it was resolved that the company be wound up voluntarily and at an adjourned meeting of creditors held on the same day it was resolved that for such purposes Robert A. Waters and Robert P. Orr, Chartered Accountants of 470 Bourke Street, Melbourne, be appointed joint liquidators.

Notice is also given that after twenty-one days from this date we shall proceed to distribute the assets. All creditors who have any claim against the company should furnish particulars of same by that date, otherwise we shall proceed to distribute the assets without regard to their claim.

Dated this 11th day of February, 1977.

ROBERT A. WATERS,  
ROBERT P. ORR,  
Joint Liquidators.

Lewis Luckins & Co., chartered accountants, 470 Bourke Street, Melbourne. 3000. Telephone 67 6944. 6251

*Companies Act 1961.*

## THE OPHTHALMIC ASSOCIATION (IN VOLUNTARY LIQUIDATION).

## NOTICE OF FINAL MEETING PURSUANT TO SECTION 272.

Notice is hereby given that a General Meeting of the members of the above Association will be held at Room 10-2, 201 Spring Street, Melbourne, at 11 a.m. on 25th March, 1977 for the purpose of having an account laid before them showing the manner in which the winding up has been conducted, the property of the Association disposed of and of giving any explanation of the account.

Dated this 9th day of February, 1977.

6266

E. C. HAUSER, Liquidator.

*The Companies Act 1961.*

## CIRCUIT BOARD MANUFACTURES AUSTRALIA PTY. LIMITED (IN VOLUNTARY LIQUIDATION).

*Notice Re Winding Up.*

Notice is hereby given that at meetings of members and creditors held on the 3rd day of February 1977, it was resolved that the Company be wound up voluntarily and that Michael Ashley Coppins and John Barry Hutchins, Chartered Accountants of 271 William Street, Melbourne, be appointed joint and several liquidators of the Company.

Notice is also given that creditors proofs of debt should be lodged with the liquidator within 21 days of the date hereof in order to participate in any distribution.

Dated this 7th day of February, 1977.

M. A. COPPINS & J. B. HUTCHINS, Liquidators.

Wilson, Bishop, Bowes & Craig, 271 William Street, Melbourne, 3000. 6252

## H. WILLIAMSON &amp; DALTON PTY. LTD.

## (IN VOLUNTARY LIQUIDATION)

Notice is hereby given, in pursuance of Section 272 of the *Companies Act 1961*, that a General Meeting of the members of the abovenamed Company will be held at the offices of Touche Ross & Co., 440 Collins Street, Melbourne on Friday, 18th March, 1977 at 10.00 a.m., for the purpose of having the liquidator's account laid before them showing the manner in which the winding up has been conducted and the property of the Company disposed of and of hearing any explanation that may be given by the liquidator, and also of determining the manner in which the books, accounts and documents of the Company and of the liquidator thereof shall be disposed of.

Dated the 10th February, 1977.

GRAHAM E. DUNSHEA, Liquidator.

Touche Ross & Co., 440 Collins Street, Melbourne. 6264

## BRIGHT STREET HOLDINGS PTY. LTD.

## (IN VOLUNTARY LIQUIDATION)

Notice is hereby given, in pursuance of Section 272 of the *Companies Act 1961*, that a General Meeting of the members of the abovenamed Company will be held at the offices of Australian Paper Manufacturers Limited, 4 South Gate, South Melbourne, on Friday, 18th March, 1977 at 11.00 a.m., for the purpose of having the liquidator's account laid before them showing the manner in which the winding up has been conducted and the property of the Company disposed of and of hearing any explanation that may be given by the liquidator, and also of determining the manner in which the books, accounts and documents of the Company and of the liquidator thereof shall be disposed of.

Dated the 10th February, 1977.

GRAHAM E. DUNSHEA, Liquidator.

Touche Ross & Co., 440 Collins Street, Melbourne. 6265

*The Companies Act 1961.*—In the matter of SUPERIOR STEELSHEET INDUSTRIES PTY. LTD.—Notice re Meeting of Creditors Pursuant to Section 260.

Notice is hereby given that a Meeting of Creditors of the abovenamed Company will be held in the Meeting Room, Wallace, McMullin & Smail, 499 St. Kilda Road, Melbourne on Tuesday, the 1st day of March, 1977 at 11.00 a.m., the Company having convened a Meeting of its Members for the same day for the purpose of considering a Resolution that the Company be wound up voluntarily.

Dated this 15th day of February, 1977.

A. W. CLARK, Director.

Wallace, McMullin & Smail, Chartered Accountants.

6271

In the matter of the *Companies Act 1961*; and in the matter of RICHARD ELLIS, SALLMANN & SEWARD (AUSTRALIA) PTY. LIMITED (in Voluntary Liquidation).—Notice of Final Meeting of Members, Pursuant to Section 272.

Notice is hereby given in pursuance of Section 272 of the *Companies Act 1961* that a General Meeting of the members of the Company will be held at the office of Messrs. Coopers & Lybrand, 461 Bourke Street, Melbourne on the 18th day of March, 1977, at 10.00 o'clock in the forenoon for the purpose of having an account laid before it showing the manner in which the winding up has been conducted and the property of the company disposed of, and hearing any explanation that may be given by the liquidator.

Dated this 11th day of February, 1977.

R. W. BETTS, Liquidator.

Messrs. Coopers & Lybrand, Chartered Accountants, 461 Bourke Street, Melbourne, Vic. 3000. 6273

MARY ALICIA BRYAN, late of 23 Ayr Street, Doncaster, in the State of Victoria, widow, DECEASED.

Creditors, next-of-kin and others having claims in respect of the Estate of the deceased who died on the 17th day of June, 1976 are required by the Trustees the Trustees Executors and Agency Company Limited of 403 Collins Street Melbourne in the said State, to send particulars to them care of their Solicitors, Messrs. Aughterson Giblett & Williams in the said State by the 15th day of April, 1977 after which date the Trustees may convey or distribute the assets having regard only to the claims of which they then have notice.

AUGHTERSON, GIBLETT & WILLIAMS, of 156 Ma-roondah Highway, Ringwood. 6182

Creditors next of kin and others having claims in respect of the Estate of Florence Joyce Bishop late of 4 Levien Street Essendon in the State of Victoria Teacher deceased who died on the 3rd day of August 1976 are required by the Executors the Trustees Executors and Agency Company Limited to send particulars to the said Company at 401 Collins Street Melbourne in the said State by the 20th day of April 1977 after which date it will distribute the assets having regard only to the claims of which it then has notice.

PRICE & CHAMBERLIN, solicitors, 180 William Street, Melbourne. 6183

HENRY ARTHUR BATESON, late of 3 Albert Road, Drouin, in the State of Victoria, retired farmer, DECEASED.

Creditors next of kin and others having claims in respect to the estate of the deceased who died on the 23rd day of July 1976 are required by the Trustees Arthur Gordon Bateson and Raymond Allan Bateson and Sybil Doreen Cameron to send particulars of their claims to them care of the undersigned Solicitors by the 19th April 1977 after which date the Trustees may convey or distribute the assets having regard only to the claims of which they then have notice.

GRAY, FRIEND & LONG, solicitors, Warragul. 6184

FRANCES BRYCE, late of Culgoa, in the State of Victoria, widow, DECEASED, intestate.

Creditors, next of kin, and others having claims in respect of the estate of the deceased (who died on the 23rd day of November, 1975) are required by the administrator Stanley Hugh Ellis of Sea Lake in the said State to send particulars to him care of the undersigned by the 13th day of April, 1977, after which date the administrator may convey or distribute the assets having regard only to the claims of which he then has notice.

HAYES (ALEC M.) & MCINERNEY, solicitors, 148 Campbell Street, Swan Hill. 6185

JOHN CORNELIUS MCCARTHY, late of 169 Orrong Road, East St. Kilda, gentleman, DECEASED, who died on the 19th day of June, 1975.

Creditors next of kin and others having claims against the Estate of the deceased are required by the Executrix of his Will Dorothy Jean Moffatt of 174 Orrong Road North Caulfield Married Woman to send particulars thereof to her care of Don & Edney, Box 207 Elsternwick before the 23rd day of April 1977 after which date she may distribute the assets of the deceased having regard only to the claims of which she then has notice.

DON & EDNEY, solicitors, 24-26 Riddell Parade, Elsternwick. 6208

**GWENDOLYN AMY HISCOCK**, late of 1187 Burke Road, Kew, in the State of Victoria, gentlewoman.

Creditors, next of kin and others having claims in respect of the estate of the deceased (who died on the 4th day of October 1976) are required by The Perpetual Executors and Trustees Association of Australia Limited of 50 Queen Street, Melbourne, to send particulars of their claims to the said Company by the 19th day of May 1977 after which date it will convey or distribute the assets, having regard only to the claims of which the Company then has notice.

**GIBSON, MCINTOSH & ASSOCIATES**, solicitors, of 825 Burke Road, Camberwell. 6209

Creditors, next-of-kin and others having claims in respect of the unadministered Estate of Alice Elizabeth Spencer late of 8 Lewis Street, Mordialloc in the State of Victoria, Widow deceased intestate who died on the 14th December, 1948, are required by the Administratrix of her Estate Winifred Iris Darnett of 12 Chaprow Court, Cheltenham in the said State, Married Woman, to send particulars of their claims to the said Administratrix care of the undermentioned Solicitor by the 9th day of April, 1977 after which date the said Administratrix may convey or distribute the assets having regard only to the claims of which she then has notice.

**ROWLAND P. HASSALL**, solicitor, 360 South Road, Moorabbin. 6210

**FRANCIS JAMES CRAMERI**, late of 29 St. David Street, North Geelong, gentleman, DECEASED.

Creditors next of kin and others having claims against the estate of the abovenamed deceased are required by the Executor thereof John Rupert Hyett of 482 Glenferrie Road, Hawthorn, Solicitor to send particulars thereof to him care of the undermentioned Solicitors on or before the 18th day of April, 1977 after which date he will distribute the assets of the said estate having regard only to the claims of which he then has notice.

Dated the 11th day of February, 1977.

**HYETT, ELLINGHAUS, JOHN & MORRISON**, of 51 Bull Street, Bendigo, solicitors for the executor. 6211

In the Will of **JOHN LUDWIG PAUL RADDATZ**, formerly of 14 Patricia Street, Enfield, in the State of New South Wales, but late of 13 Woodgee Street, Currumbin, in the State of Queensland, master mariner, DECEASED.

Creditors next of kin and others having claims in respect of the estate of the abovenamed deceased (who died on the seventeenth day of December 1975) are required by the Executrix Catherine Raddatz of 14 Patricia Street Enfield Sydney New South Wales widow to send particulars of their claims to her care of the undermentioned solicitors by the 16th day of April 1977 after which date she will distribute the assets having regard only to the claims which she shall then have notice.

**AITKEN, WALKER & STRACHAN**, solicitors, of 114 William Street, Melbourne. 6294

**ALICE FANNY WALLER**, late of 45 Grant Street, East Malvern.

Creditors next of kin and others having claims in respect of the estate of the deceased who died on the 16th May, 1975 are required by the personal representatives Eric Hale Waller of 43 Grant Street, East Malvern and Dawn Wilson of 23 Normandy Road, Elwood to send particulars of their claims to Eric Hale Waller by the 24th April, 1977 after which date they will convey or distribute the assets having regard only to the claims of which they then have notice.

**HEDDERWICK, FOOKES & ALSTON**, of 121 William Street, Melbourne. 6295

**JOHN CARTER**, late of Unit 2, 84-86 Locksley Road, Ivanhoe.

Creditors next of kin and others having claims in respect of the estate of the deceased who died on 19th June, 1976 are required by the personal representative The Trustees Executors and Agency Company Limited of 401 Collins Street, Melbourne to send particulars of their claims to it by the 24th April, 1977 after which date it will convey or distribute the assets having regard only to the claims of which it then has notice.

**HEDDERWICK, FOOKES & ALSTON**, of 121 William Street, Melbourne. 6296

**BERYL GIBSON MEE**, late of 10 Camborne Avenue, Mt. Eliza.

Creditors next of kin and others having claims in respect of the estate of the deceased who died on 24th November, 1975 are required by the personal representative Cyril George Mee of 10 Camborne Avenue, Mt. Eliza to send particulars of their claims to him by the 24th April, 1977 after which date he will convey or distribute the assets having regard only to the claims of which he then has notice.

**HEDDERWICK, FOOKES & ALSTON**, of 121 William Street, Melbourne. 6297

**HOWARD ALFRED JACKEL**, late of 8 Harrison Avenue, Burwood.

Creditors next of kin and others having claims in respect of the estate of the deceased who died on 19th August, 1973 are required by the personal representative Pearl Elsie Hunter of 6 Harrison Avenue, Burwood to send particulars of their claims to her by the 24th April, 1977 after which date she will convey or distribute the assets having regard only to the claims of which she then has notice.

**HEDDERWICK, FOOKES & ALSTON**, of 121 William Street, Melbourne. 6298

Creditors next of kin and others having claims in respect of the estate of Violet Vera Jackson late of 9 Elphinstone Street West Footscray married woman deceased who died on the 17th November, 1976 are to send particulars of their claims to The Union Fidelity Trustee Company of Australia Limited of 100 Exhibition Street Melbourne by the 18th April 1977 after which date it will distribute the assets having regard only to the claims of which it then has notice.

**MARTIN & MARTIN**, solicitors, 37 Queen Street, Melbourne. 6299

Creditors next of kin and other persons having claims against the estate of Harold Homer Kennedy formerly of 8 Pickford Street East Prahran but late of "St. Ronan's" Hospital 51 Adelaide Street Armadale Retired deceased who died on 23rd October 1976 are required to send particulars of their claims to the Executor Bryan James Ogge in care of the undermentioned solicitors by the 18th day of April 1977 after which date the Executor will distribute the assets having regard only for the claims of which he then has had notice.

**JAMES P. OGGIE & CO.**, solicitors, 165 Greville Street, Prahran. 6274

**MARTIN JAMES KINNANE**, late of Coleraine, in the State of Victoria, retired, DECEASED, intestate.

Creditors next of kin and others having claims in respect of the estate of the deceased who died on the 4th day of October 1975 are required by the Administrator Lionel Martin Kinnane of Hamilton Road Coleraine in the State of Victoria to send particulars to him in care of the undermentioned Solicitors by the 1st day of May 1977 after which date the said Administrator may convey or distribute the assets having regard only to the claims of which he then has notice.

Dated the 11th day of February, 1977.

**MELVILLE, ORTON & LEWIS**, solicitors, 83c Whyte Street, Coleraine. 6275

Creditors, next of kin and others having claims in respect of the Estate of Norman Arthur Sutherland late of 65 Fitzroy Street, Sale in the State of Victoria, Pipeline Operator deceased intestate who died on the 10th day of August, 1976, are required by the Administrator Joseph Middleton of Main Road, Seaspray in the State of Victoria, Labourer to send particulars to him C/- Messrs. J. Crofton, Lee & Moir, Solicitors of 233 Raymond Street, Sale, by the 9th day of May, 1977, after which date the Administrator may distribute the assets of the Estate having regard only to the claims of which he then has notice.

**J. CROFTON, LEE & MOIR**, solicitors of 233 Raymond Street, Sale. 6276

Creditors next of kin and others having claims in respect of the Will of Florence Coburn late of 2 Oak Street Flemington Married Woman who died on the 29th day of August 1976 are requested to send particulars of their claims to the Executor George Henry Coburn care of the undermentioned Solicitor by the 27th day of April 1977 after which date he will distribute the assets having regard only as to the claims of which he then has notice.

**JOHN STEWART**, of 290 Racecourse Road, Newmarket. 6277



OSWALD JAMES OLSEN, late of 394 Nepean Highway, Frankston, gentleman, DECEASED.

Creditors next of kin and others having claims in respect of the estate of the deceased who died on the 30th day of October 1976 are required by National Trustees Executors and Agency Company of Australasia Limited of 95 Queen Street Melbourne Francis Gregory Murphy of 4 Haldane Street Beaumaris Gentleman and William Archer Harrison of 28 Belgrave Road East Malvern Retired Bank Manager the applicants for a grant of administration to send particulars of their claims to the said applicants in the care of the said Company by the 19th day of April 1977 after which date they will convey or distribute the assets having regard only to the claims of which they then have notice.

MADDEN BUTLER ELDER & GRAHAM, solicitors, 500 Collins Street, Melbourne. 6257

Creditors next of kin and others having claims in respect of the Estate of Esme Emily Sophie Warriner late of 1765 Dandenong Road, East Oakleigh, Retired Teacher deceased who died on the 21st day of October 1976 are required by the executor, Robert Watson Love of 520 Neerim Road, Murrumbena, Estate Agent, to send particulars of their claims to him at the office of the undermentioned solicitors by the 27th day of April 1977 after which date the executor will distribute the assets having regard only to the claims of which he then has notice.

LYNCH & MACDONALD, solicitors, of 118 Queen Street, Melbourne. 6258

Creditors next of kin and all other persons having claims against the estate of Frederick James Harris late of 13 Ashley Grove Malvern Retired deceased who died on 20th November 1976 are required by the Executrix Penelope Alice Magnus of 38 Margaret Street Box Hill Married Woman to send particulars of their claims to her C/- the undersigned by the 17th April 1977 after which date she will proceed to distribute the estate having regard only to the claims of which she then has notice.

JOHN D. MUSTOW & CO., solicitors, 131 Queen Street, Melbourne. 6259

ARTHUR LAURIE PAUL, late of 119 Deakin Avenue, Mildura, retired, DECEASED.

Creditors next-of-kin and others having claims in respect of the estate of the abovenamed deceased, who died on the 9th July 1976 are required by the Executor Frederick Maurice Van Cuylenburg of 450 Little Collins Street, Melbourne Solicitor to send particulars to him in care of the undermentioned Solicitors by 20th April 1977 after which date the Executor may convey or distribute the assets having regard only to the claims of which he then has notice.

FLOOD & PERMEZEL, solicitors, 450 Little Collins Street, Melbourne. 6260

Creditors next-of-kin and others having claims in respect of the Estate of Eileen Cass Ruff late of Flat 6 "Strathallan" Coleraine but formerly late of 4 Compton Street, Canterbury Widow deceased who died on the 27th day of January, 1976, are required to send particulars of their claims to the Executors Anne Kathleen Kealy and Richard Abraham Ruff care of the undermentioned Solicitors by the 21st April, 1977 after which date they will distribute the assets having regard only to the claims of which they then have notice.

ROYSTON CAHIR & MARTIN, solicitors, 17 Queen Street, Melbourne. 6261

HECTOR ROBERT BARCLAY, late of 25 Peel Street, Kew, retired, public servant, DECEASED.

Creditors next of kin and others having claims in respect of the estate of the deceased who died on 18th September 1976 are required by the executor Caroline Dorothy Barclay of 25 Peel Street Kew Widow to send particulars to her care of the under mentioned solicitors by the 18th day of April 1977 after which date the executor may convey or distribute the assets having regard only to the claims of which she then has notice.

HADEN SMITH & FITCHETT, solicitors, 423 Bourke Street, Melbourne. 6262

Creditors next of kin and others having claims in respect of the Will of Alexander George Maver formerly of 18 Hoad Street North Sunshine but late of Horsford Lodge Rest Home, 101 Droop Street, Footscray Retired who died on the 31st day of December 1976 are requested to send particulars of their claims to the Executor George Warwick Maver care of the undermentioned Solicitor by the 27th day of April 1977 after which date he will distribute the assets having regard only as to the claims of which he then has notice.

JOHN STEWART, of 290 Racecourse Road, Newmarket.

6278

Creditors next of kin and others having claims in respect of the estate of Otto Mueller (also known as Otto Johann Mueller) late of 12 Gumer Street, St. Kilda in the State of Victoria Mechanical Plant Driver deceased who died on the 8th day of December, 1976 are to send particulars of their claims to The Trustees Executors and Agency Company Limited of 401 Collins Street, Melbourne by the 20th day of April, 1977 after which date it will distribute the assets having regard to the claims of which it then has notice.

WILLIAM, HARRISON & SON, solicitors, 11 Bank Place, Melbourne. 6279

FLORENCE BETTS, late of 4 Barker Street, California Gully, retired teacher, DECEASED.

Creditors next of kin and others having claims against the estate of the abovenamed deceased are required by the Executors thereof Edward Alfred Betts of 3 Blackie Avenue Ararat Retired and John Rupert Hyett of 482 Glenferrie Road Hawthorn Solicitor to send particulars thereof to them care of the undermentioned Solicitors on or before the 18th day of April 1977 after which date they will distribute the assets of the said estate having regard only to the claims of which they then have notice.

Dated the 10th day of February, 1977.

HYETT, ELLINGHAUS, JOHN & MORRISON, of 51 Bull Street, Bendigo, solicitors for the executors. 6212

Creditors next of kin and others having claims against the Estate of Arthur Bothwell Carter late of 18 Clarendon Street Benalla in the State of Victoria Retired Farmer deceased who died on the 12th day of June 1976 are required by the Trustees in the said Estate Ina Myrtle Dahl of 18 Clarendon Street Benalla aforesaid Widow and Doris Jean Rogash of 22 George Street Benalla aforesaid Married Woman to send details of their claims to the Trustees care of the undermentioned Solicitor by the 9th May 1977 after which date the Trustees will convey or distribute the assets having regard only to the claims of which they have notice.

DENIS JOHNSTON, solicitor, corner Bridge and Nunn Streets, Benalla. 6227

FRANCIS WILLIAM CASHEN, formerly of 32 Aitchison Avenue, Ashburton, fruiterer, but late of 65 Brandon Street, Burwood, retired Commonwealth public servant, DECEASED.

Creditors next of kin and all others having claim against the estate of the abovenamed deceased who died on the 11th day of April 1975 are required by Madge Nellie Cashen of 65 Brandon Street Burwood to whom Letters of Administration with the will annexed have been granted to send particulars of such claims to the said Administrator care of the under-mentioned solicitors before the 18th of April 1977 after which date she may distribute and convey the assets of the deceased having regard only to the claims of when she then has notice.

JOHN I. SULLIVAN CHISHOLM & ASSOCIATES, Box 35, South Caulfield 3162, corner of Kooyong and Glenhunting Roads, South Caulfield. 6228

LORRAINE CLAIRE GIBSON, late of 23 Jeffrey Street, Mount Waverley, journalist, DECEASED.

Creditors next of kin and others having claims in respect of the Estate of the deceased who died on the 15th day of April 1976 are required by Geoffrey Allan Sanders of 30 Mockridge Crescent Holt Australian Capital Territory to send particulars of their claims to him by the 18th day of April 1977 after which date he will convey or distribute the assets having regard only to the claims of which he then has notice.

PAVEYS, solicitors, 390 Lonsdale Street, Melbourne.

6248

Creditors next of kin and others having claims in respect of the estate of Fanny Caroline Moorhead late of 231 Main Street Bacchus Marsh Married Woman deceased who died on the 6th day of May 1976 and Probate of whose Will has been granted to Leigh Hamilton Moorhead of 231 Main Street Bacchus Marsh Retired are required to send particulars of their claims to the said Executor care of the undermentioned Solicitors by the 14th day of April 1977 after which date he will distribute the assets having regard only to the claims of which he then has notice.

PEARCE & WEBSTER, solicitors, 430 Little Collins Street, Melbourne. 6249

Creditors next-of-kin and others having claims in respect of the Estate of Kenneth Stewart Taylor late of 4 Lawrence Street, Heidelberg Gentleman deceased who died on the 14th day of November, 1976 and Probate of whose Will has been granted to The Trustees Executors and Agency Company Limited of 401 Collins Street, Melbourne are required to send particulars of their claims to the said executor by the 18th day of April, 1977 after which date it will distribute the assets having regard only to the claims of which it then has notice.

H. L. YUNCKEN & YUNCKEN, solicitors, 443 Little Collins Street, Melbourne, 3000. 6250

FRANK STEWART DETHRIDGE, late of 22 Verdant Avenue, Toorak, in the State of Victoria, solicitor, DECEASED.

Creditors next of kin and others having claims in respect of the estate of the deceased who died on the 4th day of June 1976 are required by The Perpetual Executors and Trustees Association of Australia Limited of 50 Queen Street Melbourne in the said State and Enid Dethridge of 22 Verdant Avenue Toorak aforesaid Widow the applicants for a grant of administration to send particulars of their claims to the said applicants in the care of the said Company by the 18th day of April 1977 after which date they will convey or distribute the assets having regard only to the claims of which they then have notice.

MALLESONS, solicitors, 121 William Street, Melbourne. 6253

DOROTHY ELIZABETH DILL EDWARDS (in the Will called Dorothy Elizabeth Edwards) formerly of 27 Boomerang Street, Turrumurra, New South Wales, but late of Cambridge Convalescent Home, 1 Erith Street, Mosman, New South Wales, gentlewoman, DECEASED.

Creditors next of kin and others having claims against the Estate of the deceased who died on 12th September 1976 are required by the Executor The Trustees Executors and Agency Company Limited of 401 Collins Street Melbourne to send particulars of their claims to the said Company on or before the 18th April 1977 after which date it will convey or distribute the assets having regard only to the claims of which it then has notice.

HOME, WILKINSON & LOWRY, solicitors of 401 Collins Street, Melbourne. 6254

Creditors and persons having claims against the estate of Keith Barron late of 39 Albert Road, Melbourne Retired Spray Painter deceased intestate who died on the 14th day of October, 1976 are required to lodge their claim with the executor Douglas Barron care of the undermentioned solicitors by the 15th day of April, 1977 after which date he will distribute the assets having regard only to the claims which he then has notice.

J. A. REDMOND & CO., 482 Bourke Street, Melbourne. 6255

Creditors next of kin and others having claims in respect of the estate of Reginald Webster late of 36 Laura Grove Hawthorn East Retired Medical Practitioner deceased who died on 8th November 1976 are to send the particulars of their claims to the Trustees Executors and Agency Company Limited of 401 Collins Street Melbourne by the 18th day of April 1977 after which date it will distribute the assets having regard only to the claims of which it then has notice.

HADEN SMITH & FITCHETT, solicitors, 423 Bourke Street, Melbourne. 6256

Creditors Next of Kin and others having claims in respect of the estate of Mary Elizabeth Cass late of Cornell Street, East Camberwell Spinster deceased who died on the 23rd day of October, 1976 are to send particulars of their Claims to National Trustees Executors and Agency Company of Australasia Limited of 95 Queen Street, Melbourne by the 21st day of April, 1977 after which date it will distribute the assets having regard only to the Claims of which it shall then have had notice.

M. MORRANE, solicitor, 118 Queen Street, Melbourne. 6300

In the Supreme Court of the State of Victoria.

SALE BY THE SHERIFF.

On Friday the 18th of March 1977 at 10.30 a.m. at the Police Station Elwood (unless process be stayed or satisfied).

All the Estate and Interest (if any) of Mobile Hoists (Victoria) Pty. Ltd., company of 85 Tennyson Street, Elwood as proprietor of an estate in fee simple in the land described in Certificate of Title Volume 3525 Folio 985 upon which is erected a detached weatherboard house known as No. 7 Rothesay Avenue Elwood.

Registered Mortgage No. F.695485 affects the said estate and interest.

Terms—Cash only.

6323 DOUGLAS S. HALL, Sheriff's Officer.

In the Supreme Court of the State of Victoria.

SALE BY THE SHERIFF.

On Friday the 25th of March 1977 at 10.30 a.m. at the Police Station Caulfield (unless process be stayed or satisfied).

All the Estate and Interest (if any) of Susanne Buntman, (shown on Certificate of Title as Suzanne Malka Buntman) married woman, of 99 Kooyong Road, Caulfield as proprietor of an estate in fee simple in the land described in Certificate of Title Volume 5260 Folio 858 which is a vacant block of land known as No. 22 Takapuna Street Caulfield.

Registered Mortgages Nos. E.701869, F.35328 and F.582057 and Caveats Nos. F.215421 and F.804886 affects the said estate and interest.

Terms—Cash only.

6324 DOUGLAS S. HALL, Sheriff's Officer.

In the Supreme Court of the State of Victoria.

SALE BY THE SHERIFF.

On Friday the 25th of March 1977 at 12 noon at the Police Station Carlton (unless process be stayed or satisfied).

All the Estate and Interest (if any) of Roger Harold Lamb, electrical engineer, of 27 Nicholson Street, Carlton as proprietor of an estate in fee simple in the land described in Certificate of Title Volume 395 Folio 922 upon which is erected a dwelling house known as No. 27 Nicholson Street Carlton.

Registered Mortgage No. G.482233 affects the said estate and interest.

Terms—Cash only.

6325 DOUGLAS S. HALL, Sheriff's Officer.

In the Supreme Court of the State of Victoria.

SALE BY THE SHERIFF.

On Friday the 18th of March 1977 at 10.30 a.m. at the Police Station Croydon (unless process be stayed or satisfied).

All the Estate and Interest (if any) of Graham John McDonald, technician and Judith Margaret McDonald, married woman, both of 27 Kallay Street, West Croydon as joint proprietors of an estate in fee simple in the land described in Certificate of Title Volume 8704 Folio 209 upon which is erected a brick dwelling with cement tiled roof known as No. 27 Kallay Street West Croydon.

Registered Mortgage No. G.151926 affects the said estate and interest.

Terms—Cash only.

6326 H. BUETTNER, Sheriff's Officer.

In the Supreme Court of the State of Victoria.

**SALE BY THE SHERIFF.**

On Friday the 18th of March 1977 at 10.30 a.m. at the Police Station Brunswick (unless process be stayed or satisfied).

All the Estate and Interest (if any) of Elpida Rigopoulos, married woman, of 6 Connelly Street, Brunswick as proprietor of an estate in fee simple in the land described in Certificate of Title Volume 8438 Folio 492 upon which is erected a single fronted timber dwelling known as No. 6 Connelly Street Brunswick.

Registered Mortgage No. E.937053 and Caveats F.635009, F.797423 and F.898190 affect the said estate and interest.

Terms—Cash only.

6327 KEITH R. MARTIN, Sheriff's Officer.

In the Supreme Court of the State of Victoria.

**SALE BY THE SHERIFF.**

On Friday the 25th of March 1977 at 10.30 a.m. at the Police Station Avondale Heights (unless process be stayed or satisfied).

All the Estate and Interest (if any) of Joseph Paparone (shown on Certificate of Title as Joseph Anthony Paparone), men's hairdresser, of 28 Rogerson Street, Avondale Heights as proprietor of an estate in fee simple in the land described in Certificate of Title Volume 8437 Folio 689 upon which is erected a dwelling and outbuildings known as No. 28 Rogerson Street, Avondale Heights.

Registered Mortgages Nos. C.31070 and E.473172, Caveats Nos. E.16587, F.177378 & F.512129 affect the said estate and interest.

Terms—Cash only.

6272 KEITH R. MARTIN, Sheriff's Officer.

**IMPOUNDING**

KYNETON.—Impounded in Kyneton Pound on Friday, 11th February, 1977, from the Central Road area.

1 black steer  
1 roan Shorthorn crossbred heifer

If not claimed and expenses paid, will be sold on 3rd March, 1977.

6284—\$4.40 J. A. BARKLEM,  
Acting Poundkeeper.

*Subordinate Legislation Act 1962.*

**NOTICE OF MAKING OF STATUTORY RULES.**

In pursuance of the provisions of the *Subordinate Legislation Act 1962* and the Regulations made thereunder, notice is given of the making of the following statutory rules:—

No.	Country Fire Authority Act 1958.	Price.
28/1977.	Country Fire Authority (Superannuation Fund and Superannuation and Endowment Assurance Fund) (Revocation) Regulations 1977	10c
	<i>Motor Car Act 1958.</i>	
29/1977.	Motor Car (Blood Samples) Regulations 1977	20c
	<i>Local Government Act 1958.</i>	
30/1977.	Postal Voting (Elections of Municipal Councillors (Amendment) Regulations 1977	10c
	<i>Public Service Act 1974.</i>	
PSD11/1977.	Public Service Determinations	10c
PSD12/1977.	Public Service Determinations	10c
PSD13/1977.	Public Service Determinations	10c

Copies of these statutory rules may be purchased at the Sale of Publications Section of the Government Printing Office, located at 7A Parliament Place, Melbourne, 3002. If ordered by mail, remittance should be addressed to "The Government Printer, Box 203, P.O., North Melbourne, 3051", and should include 20c extra for postage.

The annual subscription rates for Statutory Rules for the year commencing 1st January, 1976, payable in advance, are as follows:—

Statutory Rules (other than Public Service Determinations)	\$45.00
Public Service Determinations	\$20.00

C. H. RIXON,  
Government Printer.

**STATE ACTS, 1976**

Copies of the following Acts of the Parliament of Victoria may be obtained at the Government Printing Office, Sale of Publications Branch, 7A Parliament Place, Melbourne, phone 63 0321, extension 6181, or from any accredited agent, at the price set opposite to each (these prices do not include postage).

Postage costs must be added to your remittance when ordering by mail as follows:—

Act Price.	Postage Cost.
10c-40c	20c
45c-70c	30c
75c-\$1.70	40c
\$1.75-\$4.00	60c
Above \$4.00	86c

Bound Volumes of 1975 State Acts are also available at a cost of \$21.

No.	PRICE.
8826. Public Servants Ethical Conduct (Joint Select Committee)	\$0.10
8827. Committees (Membership)	\$0.10
8828. Joint Select Committee (Meat Industry)	\$0.10
8829. Joint Select Committee (Road Safety)	\$0.10
8830. Latrobe Valley (Manager's Qualifications)	\$0.10
8831. Ministry for the Arts (Transfer of Administration)	\$0.10
8832. Bendigo College of Advanced Education	\$0.10
8833. Ballarat College of Advanced Education	\$0.20
8834. Constitution (Responsible Ministers)	\$0.10
8835. Bees (Amendment)	\$0.10
8836. Australian Tractor Testing Station	\$0.10
8837. Liquefied Gases (Amendment)	\$0.30
8838. Business Franchise (Tobacco)	\$0.30
8839. Land (Surrender of Lands)	\$0.10
8840. Dandenong (Shepley Oval) Land	\$0.10
8841. Railways (Participation in Pipeline Operations Payments)	\$0.10
8842. Tattersall Consultations (Soccer Football Pools)	\$0.10
8843. Commonwealth and States Financial Agreement	\$0.30
8844. Trustee Companies (Union-Fidelity) Amendment	\$0.10
8845. Supply (1976-77, No. 1)	\$0.20
8846. National Gallery of Victoria (Development Collection)	\$0.10
8847. Revocation and Excision of Crown Reservations	\$0.20
8848. Pesticides (Amendment)	\$0.10
8849. Architects (Amendment)	\$0.10
8850. Gippsland Folk Museum	\$0.40
8851. Joint Select Committee (Conservation of Energy Resources)	\$0.10
8852. Tomato Processing Industry	\$0.50
8853. Judges Salaries	\$0.10
8854. Small Business Development Corporation	\$0.20
8855. Home Finance (Loans and Guarantees)	\$0.10
8856. Teaching Service (Professional Appointments)	\$0.10
8857. Friendly Societies (Amendment)	\$0.10
8858. Public Works and Services (Further Expenditure)	\$0.10
8859. Sewerage Districts (Amendment)	\$0.20
8860. Mildura College Lands (Schools Fund)	\$0.10
8861. Dandenong Valley Authority (Amendment)	\$0.10
8862. Second-hand Dealers (Charity Collectors)	\$0.30
8863. Mental Health (Amendment)	\$0.10
8864. Victorian Film Corporation	\$0.20
8865. Motor Car (Breath Testing Stations)	\$0.10
8866. Education (Minister of Special Education)	\$0.10
8867. Deakin University (Amendment)	\$0.10
8868. Public Service (Long Service Leave)	\$0.10
8869. Victorian Development Corporation	\$0.10
8870. Crimes	\$0.30
8871. Weights and Measures (Amendment)	\$0.30
8872. Wild Flowers and Native Plants Protection (Amendment)	\$0.10

STATE ACTS, 1976—continued.

No.	Price.
8873. Ministry of Transport (Amendment)	\$0.10
8874. Abattoir and Meat Inspection (Amendment)	\$0.30
8875. Local Government (Rates) Amendment	\$0.20
8876. Cluster Titles (Amendment)	\$0.10
8877. Parliamentary Allowances	\$0.10
8878. Liquor Control (Exhibition Buildings)	\$0.10
8879. Waterworks Trusts Association of Victoria (Financial Year)	\$0.10
8880. Provincial Sewerage Authorities Association of Victoria (Financial Year)	\$0.10
8881. Crown Reservations (Revocations and Excisions)	\$0.30
8882. Co-operative Housing Societies (Amendment)	\$0.10
8883. County Court (Amendment)	\$0.10
8884. Ombudsman (Municipalities)	\$0.10
8885. Racing (Amendment)	\$0.10
8886. Home Finance (Amendment)	\$0.10
8887. Victoria Grants Commission	\$0.20
8888. Local Government (City of Sunshine)	\$0.10
8889. Gordon Technical College	\$0.20
8890. Water (Amendment)	\$0.20
8891. Nar Nar Goon Land Exchange	\$0.10
8892. Forests (Advances)	\$0.10
8893. Pensioners' Rates Remission	\$0.40
8894. State Electricity Commission (Loy Yang Power Station)	\$0.10
8895. Appropriation (1976-77, No. 1)	\$3.10
8896. Vital State Projects	\$0.20
8897. Barley Marketing (Amendment)	\$0.10
8898. Labour and Industry (Amendment)	\$0.10
8899. Lands Compensation (Amendment)	\$0.10
8900. Dentists (Amendment)	\$0.30
8901. Educational Institutions (Guarantees)	\$0.10
8902. Appeal Costs Fund (Amendment)	\$0.10
8903. Co-operation (Amendment)	\$0.20
8904. Victorian Institute of Secondary Education	\$0.20
8905. Water Supply Works and Services	\$0.40
8906. Health (Fees)	\$0.10
8907. Cemeteries (Amendment)	\$0.10
8908. State Forests Works and Services	\$0.10
8909. Gold Buyers (Repeal)	\$0.10
8910. Melbourne and Metropolitan Tramways (East Burwood Tramway)	\$0.10
8911. Box Hill Land	\$0.20
8912. Liquor Control (Orderly Marketing)	\$0.10
8913. Melbourne Underground Rail Loop (Financial Contributions)	\$0.10
8914. Companies (Fees)	\$0.10
8915. Employers and Employés (Repeal)	\$0.10
8916. Gas and Fuel Corporation (Borrowing Powers)	\$0.10
8917. Teacher Housing (Amendment)	\$0.10
8918. Education (Special Developmental Schools)	\$0.10
8919. Coal Mines (Pensions)	\$0.10
8920. Mines	\$0.10
8921. Northcote Children's Home	\$0.10
8922. Victoria Racing Club (Borrowings)	\$0.10
8923. Taxation Appeals (Amendment)	\$0.10
8924. Marine (Amendment)	\$0.30
8925. Hospitals Superannuation (Amendment)	\$0.50
8926. Ports and Harbours	\$0.20
8927. Building Industry Long Service Leave (Amendment)	\$0.20
8928. Public Works and Services	\$0.20
8929. Public Service (Amendment)	\$0.10
8930. Educational Grants (Continuation)	\$0.10
8931. Transport Works and Services	\$0.10
8932. Housing (Amendment)	\$0.20
8933. Country Fire Authority (Amendment)	\$0.10
8934. Psychological Practices (Psychologists' Qualifications)	\$0.10
8935. Dietitians Registration (Fees)	\$0.10
8936. Probate Duty	\$0.10
8937. Wodonga Area Land Acquisition (Amendment)	\$0.10
8938. Building Contracts (Deposits) (Amendment)	\$0.10
8939. Railways (Penalties)	\$0.10
8940. River Improvement (United Districts)	\$0.10
8941. Mildura Irrigation and Water Trusts (Amendment)	\$0.20
8942. Magistrates' Courts (Amendment)	\$0.10
8943. Melbourne and Metropolitan Board of Works (Municipalities Contributions)	\$0.10
8944. Acts Interpretation (Amendment)	\$0.10
8945. Forests (Fire Prevention and Protection) (Amendment)	\$0.10
8946. Land Tax	\$0.10
8947. Shearers Accommodation	\$0.20
8948. Liquor Control (Fees)	\$0.10
8949. Pay-roll Tax	\$0.20
8950. Rape Offences (Proceedings)	\$0.20
8951. Supreme Court	\$0.40

STATE ACTS, 1976—continued.

No.	Price.
8952. Metropolitan Fire Brigades Superannuation	\$0.50
8953. Minerals and Energy	\$0.10
8954. Legal Profession Practice (Guarantee Fund)	\$0.20
8955. Magistrates (Summary Proceedings) (Amendment)	\$0.10
8956. Money Lenders (Credit Societies)	\$0.10
8957. Patriotic Funds (Amendment)	\$0.10
8958. Local Government (House Builders' Liability)	\$0.30
8959. Police Regulation (Long Service Leave)	\$0.10
8960. Private Agents (Amendment)	\$0.20
8961. Poisons (Drugs of Addiction)	\$0.20
8962. Constitution (Validation of Elections)	\$0.10
8963. Ministry of Immigration and Ethnic Affairs	\$0.10
8964. Motor Car (Fees)	\$0.10
8965. Marketing of Primary Products (Marketing Boards)	\$0.30
8966. Building Societies	\$1.40
8967. Water and Sewerage Authorities (Accident Insurance and Employés Long Service Leave)	\$1.30
8968. Upper Yarra Valley and Dandenong Ranges Authority	\$0.80

ACTS REPRINTED IN ACCORDANCE WITH THE AMENDMENTS INCORPORATION ACT, 1958 (No. 6422), AND FOR SALE AT THE SALE OF PUBLICATIONS BRANCH OF THE GOVERNMENT PRINTING OFFICE, 7A PARLIAMENT PLACE, MELBOURNE, 3002.

Postage costs must be added to your remittance when ordering by mail as follows:—

Act Price.	Postage Cost.
10c-40c	20c
45c-70c	30c
75c-\$1.70	40c
\$1.75-\$4.00	60c
Above \$4.00	86c

No.	Price
6189. Acts Interpretation (Fourth Reprint—Incorporating amendments up to No. 8305)	\$0.35
6191. Administration and Probate (Fourth Reprint—Incorporating amendments up to No. 7874)	\$0.75
7147. Adoption of Children (First Reprint—Incorporating amendments up to Act No. 8602)	\$0.75
6194. Agricultural Colleges (First Reprint—Incorporating amendments up to No. 7302)	\$0.15
6198. Anzac Day (First Reprint—Incorporating amendments up to No. 8344)	\$0.15
7117. Appeal Costs Fund Act 1964 (Second Reprint—Incorporating amendments up to No. 7488)	\$0.35
6201. Architects (First Reprint—Incorporating amendments up to No. 8077)	\$0.30
6202. Auction Sales Act 1958 (First Reprint—Incorporating amendments up to Act No. 8490)	\$0.35
6203. Audit (First Reprint—Incorporating amendments up to No. 7377)	\$0.35
6208. Benefit Associations (First Reprint—Incorporating amendments up to No. 6961)	\$0.65
8004. Boiler and Pressure Vessels Act 1970 (First Reprint—Incorporating amendments up to No. 8389)	\$0.45
6529. Bread Industry Act 1959 (First Reprint—Incorporating amendments up to No. 7728)	\$0.30
6973. Building Contracts (Deposits) Act 1962 (First Reprint—Incorporating amendments from No. 7315)	\$0.10
6210. Building Society (Third Reprint—Incorporating amendments up to No. 8405)	\$0.65
6213. Cancer (First Reprint—Incorporating amendments up to No. 7455)	\$0.35
6214. Carriers and Innkeepers (Second Reprint—Incorporating amendments up to No. 8534)	\$0.20
6217. Cemeteries (First Reprint—Incorporating amendments up to No. 7672)	\$0.30
6220. Clean Air Act 1958 (Third Reprint—Incorporating amendments up to Act No. 8324)	\$0.15
6221. Coal Mines (First Reprint—Incorporating amendments up to No. 7628)	\$1.05
6222. Commercial Goods Vehicles Act 1958 (Third Reprint—Incorporating amendments up to Act No. 8525)	\$0.55

ACTS REPRINTED IN ACCORDANCE WITH THE AMENDMENTS  
INCORPORATION ACT 1958 (No. 6422)—*continued.*

No.	Price.
6223. Commonwealth Arrangements ( <i>First Reprint</i> —Incorporating amendments from No. 7809)	\$0.10
6839. Companies ( <i>Sixth Reprint</i> —Incorporating amendments up to No. 8788)	\$7.90
8276. Consumer Affairs Act 1972 ( <i>Second Reprint</i> )—Incorporating amendments up to Act No. 8540	\$0.75
6224. The Constitution Act Amendment ( <i>First Reprint</i> —Incorporating amendments up to No. 8086)	\$3.05
6225. Co-operation Act ( <i>Third Reprint</i> —Incorporating amendments up to No. 8339)	\$0.85
6226. Co-operative Housing Societies ( <i>Second Reprint</i> —Incorporating amendments up to No. 7575)	\$0.53
6227. Coroners Act 1958. Reprint (No. 2) incorporating amendments up to Act No. 8184	\$0.35
6228. Country Fire Authority ( <i>Third Reprint</i> —Incorporating amendments up to No. 8813)	\$1.25
6229. Country Roads ( <i>Fourth Reprint</i> —Incorporating amendments up to Act No. 8573)	\$1.05
6230. County Court ( <i>Third Reprint</i> —Incorporating amendments up to No. 8625)	\$0.65
6231. Crimes ( <i>Fifth Reprint</i> —Incorporating amendments up to Act No. 8679)	\$2.75
6232. Crown Proceedings ( <i>Second Reprint</i> —Incorporating amendments up to No. 8731)	\$0.40
6233. Dairy Products ( <i>First Reprint</i> —Incorporating amendments up to No. 7945)	\$0.30
7060. Dandenong Valley Authority Act 1963 ( <i>First Reprint</i> —Incorporating amendments up to No. 7523)	\$0.35
6235. Dietitians Registration ( <i>First Reprint</i> —Incorporating amendments up to No. 6886)	\$0.20
4989. Discharged Servicemen's Preference Act 1943. ( <i>Second Reprint</i> —Incorporating amendments up to No. 7991)	\$0.20
6815. Disposal of Uncollected Goods Act 1961. ( <i>Second Reprint</i> —Incorporating amendments up to No. 8246)	\$0.30
8079. Dog Act 1970 ( <i>First Reprint</i> —Incorporating amendments up to No. 8664)	\$0.30
6237. Drainage Areas ( <i>First Reprint</i> —Incorporating amendments up to No. 7276)	\$0.35
6238. Drainage of Land ( <i>First Reprint</i> —Incorporating amendments up to No. 7876)	\$0.15
6239. Dried Fruits Act 1968 ( <i>First Reprint</i> —Incorporating amendments up to No. 7337)	\$0.25
6240. Education Act ( <i>Second Reprint</i> —Incorporating amendments up to No. 8659)	\$0.95
6241. Electric Light and Power ( <i>First Reprint</i> —Incorporating amendments up to No. 7315)	\$0.30
6242. Employers and Employés (Incorporating amendments up to No. 6740)	\$0.18
8056. Environment Protection Act 1970 ( <i>Second Reprint</i> —Incorporating amendments up to No. 8560)	\$0.55
6245. Estate Agents—( <i>Fifth reprint</i> —Incorporating amendments up to Act No. 8490)	\$0.85
6246. Evidence ( <i>Fourth Reprint</i> —Incorporating amendments up to No. 8228)	\$1.05
7499. Extractive Industries Act 1966 ( <i>Third Reprint</i> —Incorporating amendments up to Act No. 8647)	\$0.45
7733. Fences ( <i>First Reprint</i> —Incorporating amendments from No. 7876)	\$0.55
6468. Filled Milk ( <i>First Reprint</i> —Incorporating amendments up to No. 6886)	\$0.15
6251. Firearms ( <i>Fourth Reprint</i> —Incorporating amendments up to No. 8288)	\$0.75
6916. Foreign Judgments Act 1962 ( <i>First Reprint</i> including amendments made by No. 7332)	\$0.15
6585. Forests (Pulpwood Agreement) (Incorporating amendments up to No. 6886)	\$0.15
6254. Forests Act 1958 ( <i>Second Reprint</i> —Incorporating amendments up to No. 8702)	\$1.35
6255. Friendly Societies ( <i>First Reprint</i> —Incorporating amendments up to No. 7554)	\$0.60
6256. Fruit and Vegetables ( <i>First Reprint</i> —Incorporating amendments up to No. 6944)	\$0.30
6260. Gas and Fuel Corporation ( <i>First Reprint</i> —Incorporating amendments up to No. 7422)	\$0.70
6262. Geelong Harbor Trust ( <i>First Reprint</i> —Incorporating amendments up to No. 7547)	\$0.45
6263. Geelong Waterworks and Sewerage ( <i>First Reprint</i> —Incorporating amendments up to No. 7547)	\$0.75
8176. Gift Duty Act 1971 ( <i>First Reprint</i> —Incorporating amendments from No. 8202)	\$0.55

ACTS REPRINTED IN ACCORDANCE WITH THE AMENDMENTS  
INCORPORATION ACT 1958 (No. 6422)—*continued.*

No.	Price.
6265. Goods Act 1958 ( <i>Sixth Reprint</i> —Incorporating amendments up to Act No. 8455)	\$0.45
6266. Grain Elevators ( <i>First Reprint</i> —Incorporating amendments up to No. 7486)	\$0.35
7849. Groundwater ( <i>First Reprint</i> —Incorporating amendments up to No. 8153)	\$0.45
6267. Hairdressers Registration ( <i>First Reprint</i> —Incorporating amendments up to Act No. 7659)	\$0.30
6269. Hawkers and Pedlars Act 1958 ( <i>Second Reprint</i> —Incorporating amendments up to Act No. 8247)	\$0.40
6270. Health Act ( <i>Third Reprint</i> —Incorporating amendments up to No. 8506)	\$3.25
6531. Hire Purchase Act 1959 ( <i>Second Reprint</i> —Incorporating amendments from Act No. 8232)	\$0.55
6933. Home Finance Act 1962 ( <i>First Reprint</i> —Incorporating amendments up to No. 7363)	\$0.25
6274. Hospitals and Charities ( <i>Second Reprint</i> —Incorporating amendments up to No. 7455)	\$0.50
6275. Housing Act 1958 ( <i>Third Reprint</i> —Incorporating amendments up to Act No. 8713)	\$2.40
6276. Imprisonment of Fraudulent Debtors ( <i>First Reprint</i> —Incorporating amendments up to No. 7876)	\$0.35
6277. Industrial and Provident Societies ( <i>First Reprint</i> —Incorporating amendments up to No. 7547)	\$0.35
6279. Instruments ( <i>Fifth Reprint</i> —Incorporating amendments up to No. 8565)	\$0.75
6280. Judicial Proceedings Reports ( <i>First Reprint</i> —Incorporating amendments up to No. 7596)	\$0.15
7651. Juries ( <i>First Reprint</i> —Incorporating amendments up to No. 8170)	\$0.55
6282. Justices Act 1958 ( <i>Fourth Reprint</i> —Incorporating amendments up to No. 8338)	\$2.35
6283. Labour and Industry Act 1958 ( <i>Sixth Reprint</i> —Incorporating amendments up to Act No. 8642)	\$1.50
6284. Land Act 1959 ( <i>Third Reprint</i> —Incorporating amendments up to No. 8702)	\$3.25
6534. Land Settlement Act 1959 ( <i>First Reprint</i> —Incorporating amendments up to No. 7328)	\$0.30
6288. Land Surveyors ( <i>First Reprint</i> —Incorporating amendments up to Act No. 7065)	\$0.30
6289. Land Tax ( <i>Second Reprint</i> —Incorporating amendments up to No. 7466)	\$0.40
6285. Landlord and Tenant ( <i>Fourth Reprint</i> —Incorporating amendments up to No. 8208)	\$1.15
6286. Lands Compensation ( <i>Second Reprint</i> —Incorporating amendments up to No. 8432)	\$0.45
6290. Latrobe Valley ( <i>First Reprint</i> —Incorporating amendments up to No. 7332)	\$0.35
7919. Legal Aid—( <i>First Reprint</i> —Incorporating amendments up to Act No. 8427)	\$0.30
6291. Legal Profession Practice Act ( <i>Fourth Reprint</i> —Incorporating amendments up to No. 8778)	\$1.45
6292. Libraries ( <i>First Reprint</i> —Incorporating amendments up to No. 7364)	\$0.15
7629. Lifts and Cranes Act 1967 ( <i>First Reprint</i> —Incorporating amendments up to No. 8320)	\$0.30
6295. Limitation of Actions ( <i>Third Reprint</i> —Incorporating amendments up to No. 8300)	\$0.35
7695. Liquor Control Act 1958 ( <i>Third Reprint</i> —Incorporating amendments up to No. 8598)	\$1.35
7145. Litter Act 1964 ( <i>Second Reprint</i> —Incorporating amendments up to No. 8702)	\$0.20
6298. Local Authorities Superannuation ( <i>Second Reprint</i> —Incorporating amendments up to No. 7161)	\$0.40
6299. Local Government ( <i>Third Reprint</i> —Incorporating amendments up to No. 8781)	\$10.90
7429. Lotteries Gaming and Betting—( <i>First Reprint</i> —Incorporating amendments up to Act No. 8581)	\$0.75
8184. Magistrates' Courts ( <i>First Reprint</i> —Incorporating amendments up to Act No. 8718)	\$0.75
7289. Maintenance ( <i>First Reprint</i> —Incorporating amendments up to No. 8036)	\$1.05
6302. Marine (Incorporating amendments up to No. 7350)	\$0.72
6303. Marine Stores and Old Metals ( <i>First Reprint</i> —Incorporating amendments up to No. 7876)	\$0.35
6304. Marketing of Primary Products ( <i>First Reprint</i> —Incorporating amendments up to No. 7491)	\$0.45

ACTS REPRINTED IN ACCORDANCE WITH THE AMENDMENTS  
INCORPORATION ACT 1958 (No. 6422)—*continued.*

No.	Price.
6305. Markets Act ( <i>Second Reprint</i> —Incorporating amendments up to No. 8247)	\$0.30
6306. Marriage ( <i>Second Reprint</i> —Incorporating amendments up to No. 8602)	\$0.45
6307. Masseurs ( <i>First Reprint</i> —Incorporating amendments up to No. 7566)	\$0.20
6309. Medical Act 1958 ( <i>Third Reprint</i> —Incorporating amendments up to No. 8593)	\$0.45
8061. Medical Practitioners ( <i>First Reprint</i> —Incorporating amendments up to Act No. 8754)	\$0.75
6310. Melbourne and Metropolitan Board of Works ( <i>Fourth Reprint</i> —Incorporating amendments up to No. 8650)	\$1.95
6311. Melbourne and Metropolitan Tramways ( <i>First Reprint</i> —Incorporating amendments up to No. 7622)	\$0.70
6312. Melbourne Harbor Trust ( <i>Second Reprint</i> —Incorporating amendments up to No. 8796)	\$1.35
6405. Melbourne University ( <i>First Reprint</i> —Incorporating amendments up to No. 7871)	\$0.40
6605. Mental Health ( <i>Second Reprint</i> —Incorporating amendments up to Act No. 8679)	\$0.75
6315. Metropolitan Fire Brigades ( <i>Second Reprint</i> —Incorporating amendments up to No. 8165)	\$0.65
6316. Mildura Irrigation and Water Trusts ( <i>First Reprint</i> —Incorporating amendments up to No. 7448)	\$0.75
6317. Milk and Dairy Supervision ( <i>Second Reprint</i> —Incorporating amendments up to Act No. 8655)	\$0.85
6318. Milk Board (Incorporating amendments up to No. 7093)	\$0.22
6319. Milk Pasteurization ( <i>First Reprint</i> —Incorporating amendments up to No. 7480)	\$0.18
6320. Mines ( <i>Second Reprint</i> —Incorporating amendments up to No. 7876)	\$1.25
6184. Monash University ( <i>First Reprint</i> —Incorporating amendments up to No. 7533)	\$0.30
6324. Money Lenders ( <i>Fourth Reprint</i> —Incorporating amendments up to No. 8490)	\$0.55
6832. Motor Boating Act 1961 ( <i>Third Reprint</i> —Incorporating amendment up to No. 8662)	\$0.55
6325. Motor Car Act 1958 ( <i>Fifth Reprint</i> —Incorporating amendments up to No. 8657)	\$2.25
6713. National Fitness Council of Victoria Act 1960 ( <i>First Reprint</i> —Incorporating amendments up to No. 8344)	\$0.20
6705. Navigable Waters (Oil Pollution) Act 1960. ( <i>First Reprint</i> —Incorporating amendments up to No. 7890)	\$0.30
6328. Nurses Act ( <i>Third Reprint</i> —Incorporating amendments up to Act No. 8743)	\$0.65
8414. Ombudsman Act 1973 ( <i>First Reprint</i> —Incorporating amendments up to No. 8884)	\$0.45
6329. Opticians Registration ( <i>First Reprint</i> —Incorporating amendments up to No. 7409)	\$0.30
7723. Parliamentary Salaries and Superannuation ( <i>First Reprint</i> —Incorporating amendments up to Act No. 8687)	\$0.35
6330. Partnership ( <i>Second Reprint</i> —Incorporating amendments up to No. 7315)	\$0.35
6331. Patriotic Funds ( <i>First Reprint</i> —Incorporating amendments up to No. 7338)	\$0.25
6332. Pawnbrokers Act 1958 ( <i>Second Reprint</i> —Incorporating amendments up to Act No. 8181)	\$0.35
7417. Pensions Supplementation ( <i>First Reprint</i> —Incorporating amendments up to No. 8475)	\$0.20
6257. Pesticides Act 1958 ( <i>Second Reprint</i> —Incorporating amendments up to Act No. 8589)	\$0.35
6335. Petrol Pumps ( <i>Second Reprint</i> —Incorporating amendments up to Act No. 7315)	\$0.15
6334. Petroleum ( <i>First Reprint</i> —Incorporating amendments up to No. 7876)	\$0.65
6889. Poisons Act 1962 ( <i>Fourth Reprint</i> —Incorporating amendments up to No. 8456)	\$0.95
6337. Police Offences Act 1958 ( <i>Third Reprint</i> —Incorporating amendments up to No. 8433)	\$0.45
6388. Police Regulation ( <i>Third Reprint</i> —Incorporating amendments up to No. 8722)	\$0.95
6340. Portland Harbor Trust ( <i>First Reprint</i> —Incorporating amendments up to No. 7475)	\$0.35
6341. Pounds ( <i>First Reprint</i> —Incorporating amendments up to No. 7315)	\$0.25

ACTS REPRINTED IN ACCORDANCE WITH THE AMENDMENTS  
INCORPORATION ACT 1958 (No. 6422)—*continued.*

No.	Price.
7498. Port Phillip Authority Act 1966 ( <i>First Reprint</i> —Incorporating amendments from No. 8081)	\$0.15
6342. Printers and Newspapers ( <i>First Reprint</i> —Incorporating amendments up to No. 7876)	\$0.15
7494. Private Agents Act 1966 ( <i>Second Reprint</i> —Incorporating amendments up to Act No. 8427)	\$0.45
6344. Property Law ( <i>Third Reprint</i> —Incorporating amendments up to No. 8181)	\$1.95
6345. Public Account ( <i>First Reprint</i> —Incorporating amendments up to No. 8012)	\$0.20
6346. Public Authorities Marks ( <i>First Reprint</i> —Incorporating amendments from No. 7315)	\$0.10
8656. Public Service ( <i>First Reprint</i> —Incorporating amendments up to Act No. 8806)	\$0.95
6353. Racing ( <i>Fourth Reprint</i> —Incorporating amendments up to No. 8690)	\$1.55
6355. Railways ( <i>First Reprint</i> —Incorporating amendments up to No. 7475)	\$0.75
6564. Registration of Births Deaths and Marriages Act 1959 ( <i>First Reprint</i> —Incorporating amendments up to No. 7332)	\$0.25
6358. River Improvement Act ( <i>First Reprint</i> —Incorporating amendments up to No. 8342)	\$0.55
2596. River Murray Waters Act 1915 ( <i>First Reprint</i> —Incorporating amendments up to No. 7061)	\$0.35
6359. Road Traffic ( <i>Fourth Reprint</i> —Incorporating amendments up to Act No. 8353)	\$0.35
6360. Rural Finance ( <i>First Reprint</i> —Incorporating amendments up to No. 7328)	\$0.15
6846. Rural Finance and Settlement Commission Act 1961 ( <i>First Reprint</i> —Incorporating amendments up to No. 7332)	\$0.30
6917. Sale of Human Blood Act 1962 ( <i>First Reprint</i> —Incorporating amendments from No. 7332)	\$0.10
6975. Sale of Land Act 1962 ( <i>Second Reprint</i> —Incorporating amendments up to No. 7898)	\$0.35
8146. Scaffolding Act 1971 ( <i>Second Reprint</i> —Incorporating amendments up to Act No. 8666)	\$0.35
6363. Second-hand Dealers ( <i>First Reprint</i> —Incorporating amendments up to No. 7529)	\$0.25
7962. Securities Industry Act 1970 ( <i>First Reprint</i> —Incorporating amendments made by Act No. 8059)	\$0.65
6367. Settled Land ( <i>Second Reprint</i> —Incorporating amendments up to No. 7065)	\$0.50
6368. Sewerage Districts ( <i>Second Reprint</i> —Incorporating amendments up to No. 7547)	\$0.75
6369. Shearers Accommodation ( <i>First Reprint</i> —Incorporating amendments up to No. 7876)	\$0.35
6809. Sheep Owners Protection Act 1961 ( <i>Third Reprint</i> —Incorporating amendments up to Act No. 8247)	\$0.20
8089. Social Welfare Act 1970 ( <i>First Reprint</i> —Incorporating amendments up to Act No. 8821)	\$1.90
6372. Soil Conservation and Land Utilization Act ( <i>Third Reprint</i> —Incorporating amendments up to No. 8432)	\$0.45
6373. Soldier Settlement ( <i>First Reprint</i> —Incorporating amendments up to No. 7328)	\$0.42
6375. Stamps Act 1958 ( <i>Sixth Reprint</i> —Incorporating amendments up to Act No. 8624)	\$2.15
6377. State Electricity Commission ( <i>Second Reprint</i> —Incorporating amendments up to No. 7421)	\$0.65
6378. State Relief Committee ( <i>First Reprint</i> —Incorporating amendments from No. 6886)	\$0.10
6379. State Savings Bank Act 1958 ( <i>Third Reprint</i> —Incorporating amendments up to Act No. 8519)	\$0.95
6380. Statistics ( <i>First Reprint</i> —Incorporating amendments up to No. 6961)	\$0.15
6877. Stock (Artificial Breeding) Act 1962 ( <i>First Reprint</i> —Incorporating amendments up to Act No. 8709)	\$0.30
6383. Stock Foods ( <i>First Reprint</i> —Incorporating amendments up to No. 7607)	\$0.28
6384. Stock Medicines ( <i>First Reprint</i> —Incorporating amendments up to No. 7726)	\$0.20
7551. Strata Titles Act 1967. ( <i>Third Reprint</i> —Incorporating amendments up to Act No. 8661)	\$0.65

ACTS REPRINTED IN ACCORDANCE WITH THE AMENDMENTS  
INCORPORATION ACT 1958 (No. 6422)—*continued*.

No.	Price
6886. Subordinate Legislation Act 1962 ( <i>Second Reprint</i> —Incorporating amendments up to No. 8127) . . . . .	\$0.15
7405. Summary Offences Act 1966 ( <i>Second Reprint</i> )—Incorporating amendments up to Act No. 8276 . . . . .	\$0.55
7634. Sunday Entertainment ( <i>First Reprint</i> —Incorporating amendments up to No. 8173) . . . . .	\$0.15
6386. Superannuation ( <i>Third Reprint</i> —Incorporating amendments up to No. 8717) . . . . .	\$1.35
6387. Supreme Court ( <i>First Reprint</i> —Incorporating amendments up to No. 7522) . . . . .	\$0.75
6388. Survey Co-ordination ( <i>First Reprint</i> —Incorporating amendments up to Act No. 8107) . . . . .	\$0.35
6390. Tattersall Consultations ( <i>First Reprint</i> —Incorporating amendments up to No. 8289) . . . . .	\$0.15
6391. Teaching Service ( <i>Second Reprint</i> —Incorporating amendments up to No. 8691) . . . . .	\$0.55
6393. Theatres ( <i>First Reprint</i> —Incorporating amendments up to Act No. 8161) . . . . .	\$0.15
6849. Town and Country Planning Act 1961 ( <i>Fifth Reprint</i> —Incorporating amendments up to No. 8716) . . . . .	\$1.25
6401. Trustee ( <i>Third Reprint</i> —Incorporating amendments up to No. 7833) . . . . .	\$0.85
6402. Trustee Companies ( <i>First Reprint</i> —Incorporating amendments up to No. 7858) . . . . .	\$0.35
6397. Trade Unions ( <i>Second Reprint</i> —Incorporating amendments up to No. 8181) . . . . .	\$0.20
6399. Transfer of Land ( <i>Fifth Reprint</i> —Incorporating amendments up to No. 8531) . . . . .	\$1.15
6400. Transport Regulation Act ( <i>Second Reprint</i> —Incorporating amendments up to Act 8549) . . . . .	\$0.45
6879. Unclaimed Moneys Act 1962 ( <i>Second Reprint</i> )—Incorporating amendments up to Act No. 8448 . . . . .	\$0.20
7095. Underseas Mineral Resources Act 1963 ( <i>First Reprint</i> —Incorporating amendments from No. 7591) . . . . .	\$0.10
6653. Valuation of Land Act 1960 ( <i>Fourth Reprint</i> —Incorporating amendments up to No. 8817) . . . . .	\$0.85
6407. Vegetation and Vine Diseases ( <i>First Reprint</i> —Incorporating amendments up to No. 7423) . . . . .	\$0.30
6409. Vermin & Noxious Weeds ( <i>First Reprint</i> —Incorporating amendments up to No. 7463) . . . . .	\$0.35
6410. Veterinary Surgeons ( <i>First Reprint</i> —Incorporating amendments up to No. 7343) . . . . .	\$0.15
7291. Victoria Institute of Colleges Act 1965 ( <i>First Reprint</i> —Incorporating amendments up to No. 7644) . . . . .	\$0.25
6412. Warehousemen's Liens ( <i>First Reprint</i> —Incorporating amendments up to No. 7876) . . . . .	\$0.15
6413. Water ( <i>Third Reprint</i> —Incorporating amendments up to No. 8729) . . . . .	\$3.45
6414. Weights and Measures ( <i>Third Reprint</i> —Incorporating amendments up to No. 8068) . . . . .	\$1.05
6415. Wild Flowers and Native Plants Protection ( <i>First Reprint</i> —Incorporating amendments up to No. 6976) . . . . .	\$0.15
6416. Wills ( <i>First Reprint</i> —Incorporating amendments up to No. 7238) . . . . .	\$0.25
6417. Wire Netting ( <i>First Reprint</i> —Incorporating amendments up to No. 7876) . . . . .	\$0.45
6419. Workers Compensation ( <i>Sixth Reprint</i> —Incorporating amendments up to No. 8417) . . . . .	\$1.05
6420. Wrongs ( <i>First Reprint</i> —Incorporating amendments up to No. 8330) . . . . .	\$0.35
8344. Youth, Sport and Recreation Act 1972 ( <i>First Reprint</i> —Incorporating amendments up to Act No. 8550) . . . . .	\$0.35

## FIRST NOTIFICATION OF REPRINT.

No.	Price.
8429. Motor Accidents Act 1973 ( <i>First Reprint</i> —Incorporating amendments up to No. 8669) . . . . .	\$1.15

C. H. RIXON,  
Government Printer.

## PUBLICATION OF OFFICIAL MATTER.

Attention is invited to the following procedure in relation to the publication of official matter in the *Government Gazette*:—

Publication will be facilitated by the submission of carbon copies for the use of the Gazette Officer.

## 1. Matter submitted to the Executive Council.

Matter submitted to the Executive Council which requires gazettal will normally be published in the issue of the following week.

Where urgent gazettal is required, special arrangements should be made with the Gazette Officer, Room 14, first floor, Old Treasury Building.

## 2. Other matter.

(a) All other matter duly certified by a responsible officer for publication should be lodged with the Gazette Officer not later than half-past Nine a.m. on Tuesday.

(b) Lengthy or involved notices should be forwarded several days before publication.

(c) Proofs, which will be supplied only when specifically requested or at the direction of the Gazette Officer, should be returned promptly to avoid delay in publication.

(d) No additions or amendments to matters for publication will be accepted by telephone.

## THE "VICTORIA GOVERNMENT GAZETTE".

SUBSCRIPTIONS.—The subscription, including postage, is \$46 per annum, or \$23 per half year, payable in advance.

Subscriptions are required for whole months, and must cover at least a half year.

Subscribers do not receive the Acts of Parliament with the GAZETTE.

GAZETTES are held in stock for five years only. Single copies posted may be obtained for 70 cents.

PRIVATE ADVERTISEMENTS.—The charge for insertion is 55 cents per line single column, and \$1.10 cents per line double column. The title forms one or more lines as a heading. On an average ten words make a line of single column. Every signature must likewise be counted as a line. The final words of a paragraph, though only portion of a line, must be counted as one line. Signatures (in particular) and proper names must be written very plainly in the text; ONE SIDE ONLY of each sheet of paper should be WRITTEN UPON. The charge for a full page is \$85.

All documents illegibly written will be returned unpublished, and where brands occur unprovided for by the ordinary letters of the alphabet, a worded explanatory description must be furnished.

PUBLICATION.—A VICTORIA GOVERNMENT GAZETTE is published every WEDNESDAY EVENING, unless advertised otherwise. ADVERTISEMENTS for insertion will be received by the Government Printer not later than the day preceding publication—at ordinary rates at or before ONE p.m. and at double rates between ONE p.m. and half-past THREE p.m.

PAYMENTS.—Unless the advertiser has a credit account, all payments are required in advance. Remittances should be made by cheque, postal order, or money order payable to "GOVERNMENT PRINTER".

ADDRESS.—All communications should be addressed to "The Government Printer, Box 203, P.O., North Melbourne, 3051."

## AGENTS FOR THE "VICTORIA GOVERNMENT GAZETTE".

The following have been appointed agents to receive Advertisements and Subscriptions for the *Victoria Government Gazette*:—

ARMSTRONG'S AGENCY, 217 Queen Street, Melbourne, Victoria 3000.

ARNALL & JACKSON, 390 Barkly Street, Brunswick, Victoria 3056.

BAIRNSDALE AUTHORISED NEWSAGENCY, 132 Main Street, Bairnsdale, Victoria 3875.

BENALLA AUTHORIZED NEWSAGENCY, 45 Bridge Street, Benalla, Victoria 3672.

BLANE'S AUTHORIZED NEWSAGENTS, 162 Murray Street, Colac, Victoria 3250.

CARTER, R. G., ADVERTISING SERVICE PTY. LTD., Suite 11, 285 Carlisle Street, Balaclava, Victoria 3183.

GULLAN'S NEWSAGENCY, 88 Bridge Street, Ballarat, Victoria, 3350.

DAVIS, WM. (MILDURA) PTY. LTD., 126 Eighth Street, Mildura, Victoria 3500.

DIXON'S NEWSAGENCY, 89 Firebrace Street, Horsham, Victoria 3400.

FRANKS, H., & CO., 184 Ryrie Street, Geelong, Victoria 3220.

GATLEY, A. & J., 250 Lonsdale Street, Dandenong, Victoria 3175.

GORDON & GOTCH AUSTRALASIA LTD., 434 St. Kilda Road, Melbourne, Victoria 3004.

HAMPTON, A. C., 243 Mitchell Street, Bendigo, Victoria, 3550.

HARSTON, PARTRIDGE & CO. PTY. LTD., 455 Little Collins Street, Melbourne, Victoria 3000.

KYNETON GUARDIAN PTY. LTD., P.O. Box 18, Kyneton, Victoria 3444.

LOVELL'S SHEPPARTON NEWSAGENCY, 246 Wyndham Street, Shepparton, Victoria 3630.

THE MERCANTILE EXCHANGE, 34 Queen Street, Melbourne, Victoria 3000.

MCGILL'S AUTHORIZED NEWSAGENCY, 183-5 Elizabeth Street, Melbourne, Victoria 3000.

MCNAUGHTON, P. R. & L. A., 112-114 Gray Street, Hamilton, Vic., 3300.

POWNEY'S AUTHORIZED NEWSAGENCY, 293 Hargreaves Street, Bendigo, Victoria 3550.

PURDIE, J., & CO., 138 Moorabool Street, Geelong, Victoria 3220.

SALE AUTHORIZED NEWSAGENCY, 142 Raymond Street, Sale, Victoria 3850.

SKINNER'S AUTHORIZED NEWSAGENCY, 49-51 Franklin Street, Traralgon, Victoria 3844.

STEVENSON, A. C. & M., NEWSAGENTS, 132 Henty Street, Casterton, Victoria 3311.

VANCE'S AUTHORISED NEWSAGENCY, 83 Murray Street, Wangaratta 3677.

VERNONS OF RICHMOND, 162 Bridge Road, Richmond, Victoria 3121.

VIEW POINT AUTHORIZED NEWSAGENCY, 4 View-Point, Bendigo, Victoria 3550.

A copy of the Gazette is filed at each place for public reference.

<b>CONTENTS</b>		<b>PAGE</b>
Acts of Parliament on Sale at the Government Printing Office .. .. .		465
Appointments .. .. .		420
Companies Act 1961—Notice .. .. .		404
Contracts .. .. .		417
Country Roads Board .. .. .		407
Estates of Deceased Persons .. .. .		416
Government Notices .. .. .		400
Impounding .. .. .		465
Lands .. .. .		435
Melbourne and Metropolitan Board of Works— Notice .. .. .		411
Mining .. .. .		405
Notice of Making of Statutory Rules .. .. .		465
Orders in Council—		
Acts—Land; Local Government; Country Roads Board; Hospitals and Charities; et seq. Audit; Small Claims Tribunal; Scaffolding; Superannuation; Gordon Technical College; Water; Sewerage Districts.		422
Private Advertisements .. .. .		441
Proclamations .. .. .		399
Regulations—		
Act—Teaching Service .. .. .		442
Resignations .. .. .		422
Tenders .. .. .		441
Transport Regulation Board—Public Hearings .. .. .		401
Waterworks Trust .. .. .		410