



VICTORIA GOVERNMENT GAZETTE

Published by Authority

No. 76] WEDNESDAY, SEPTEMBER 14 [1977

PROCLAMATIONS

Land Act 1958, Section 25
ROADS PROCLAIMED

Parish of Talgarno, County of Benambra, being the land indicated by hatching on plan hereunder—(T.62(*) (Rs.1547).

PROCLAMATION

By His Excellency the Governor of the State of Victoria and its Dependencies in the Commonwealth of Australia, &c., &c., &c.

In pursuance of the provisions of Section 25 (3) (c) of the Land Act 1958, I, the Governor of the State of Victoria, by and with the advice of the Executive Council of the said State, do hereby proclaim as roads the under-mentioned lands:

Parish of Clunes, County of Talbot, being the land indicated by hatching on plan hereunder—C.395(L⁶) (L.3-300).

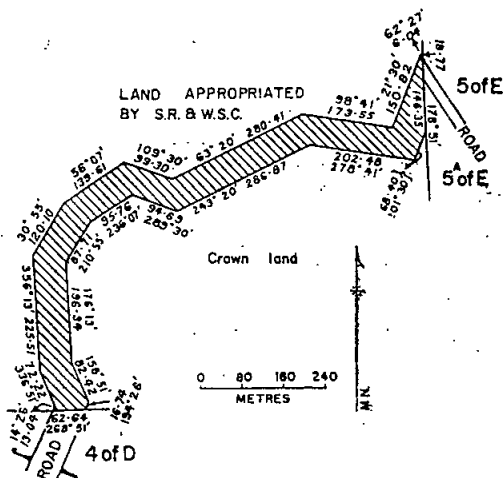
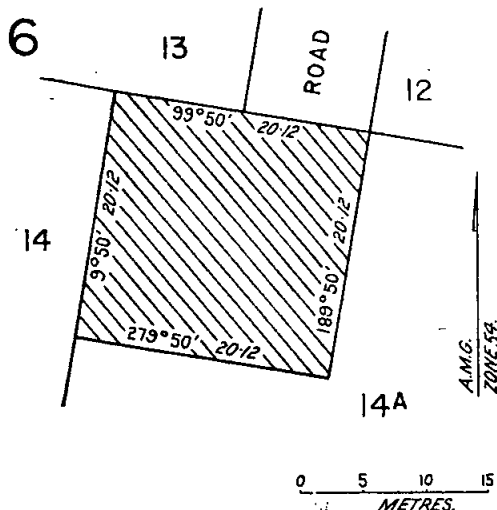

Given under my Hand and the Seal of the State of Victoria aforesaid, at Melbourne, this sixth day of September, in the year of our Lord One thousand nine hundred and seventy-seven, and in the twenty-sixth year of the reign of Her Majesty Queen Elizabeth II.

(Ls.) HENRY WINNEKE

By His Excellency's Command,
W. BORTHWICK,
Minister of Lands

GOD SAVE THE QUEEN!

PUBLIC HOLIDAYS

PROCLAMATION

By His Excellency the Governor of the State of Victoria and its Dependencies in the Commonwealth of Australia, &c., &c., &c.

In pursuance of the provisions contained in Part VI. of the Public Service Act 1974, I, the Governor of the State of Victoria, in the Commonwealth of Australia, by and with the advice of the Executive Council of the said State, do by this my Proclamation appoint the days and dates hereunder mentioned to be observed as Public Holidays or Public Half-Holidays (as the case may be) at the places respectively specified, viz:—

Public Holidays:—

WEDNESDAY, THE 5TH OCTOBER, 1977, in the Western Riding of the Shire of Waranga.

MONDAY, THE 19TH SEPTEMBER, 1977, throughout the Shire of Pyalong.

WEDNESDAY, THE 2ND NOVEMBER, 1977, within the Kyneton Riding of the Shire of Kyneton.

Public Half-Holidays from the Hour of Twelve o'clock noon:—

THURSDAY, THE 6TH OCTOBER, 1977, in the North Riding of the Shire of Wimmera.

WEDNESDAY, THE 5TH OCTOBER, 1977, throughout the Shire of Cranbourne.

Given under my Hand and the Seal of the State of Victoria aforesaid, at Melbourne, this thirteenth day of September, in the year of our Lord, One thousand nine hundred and seventy-seven, and in the twenty-sixth year of the reign of Her Majesty Elizabeth the Second, Queen of Australia.

(L.S.) HENRY WINNEKE

By His Excellency's Command,
VANCE DICKIE,
Chief Secretary

GOD SAVE THE QUEEN!

Bank Holidays Act 1958

ALTERATION OF DAY APPOINTED A BANK HOLIDAY THROUGHOUT THE TOWNSHIPS OF LANCEFIELD AND ROMSEY IN THE SHIRE OF ROMSEY

PROCLAMATION

By His Excellency the Governor of the State of Victoria and its Dependencies in the Commonwealth of Australia, &c., &c., &c.

Whereas by paragraph (g) of section 4 of the Bank Holidays Act 1958, the last Thursday in September, 1977, shall be observed as a Bank Holiday throughout the municipalities mentioned in the Second Schedule to the said Act, including the Shire of Romsey:

And whereas it is made to appear to the Governor in Council expedient that the said day should not be a Bank Holiday throughout the Townships of Lancefield and Romsey in the Shire of Romsey:

Now therefore, I, the Governor of the State of Victoria, in the Commonwealth of Australia, in pursuance of the provisions of sub-section (1) of section 7 of the Bank Holidays Act 1958, do by this my Proclamation declare that the said day shall not be a Bank Holiday throughout the Townships of Lancefield and Romsey in the Shire of Romsey and appoint Monday the 19th day of September, 1977, to be a Bank Holiday throughout the Townships of Lancefield and Romsey in the Shire of Romsey.

Given under my Hand and the Seal of the State of Victoria aforesaid, at Melbourne, this thirteenth day of September, in the year of our Lord, One thousand nine hundred and seventy-seven, and in the twenty-sixth year of the reign of Her Majesty Elizabeth the Second, Queen of Australia.

(L.S.) HENRY WINNEKE

By His Excellency's Command,
VANCE DICKIE,
Chief Secretary

GOD SAVE THE QUEEN!

Bank Holidays Act 1958
ALTERATION OF DAY APPOINTED AS A BANK HOLIDAY

PROCLAMATION

By His Excellency the Governor of the State of Victoria and its Dependencies in the Commonwealth of Australia, &c., &c., &c.

Whereas by section 4 of the Bank Holidays Act 1958, the last Thursday in September, shall be observed as a Bank Holiday throughout the municipalities listed in the Second Schedule to the said Act:

And whereas it is made to appear to the Governor in Council expedient that the said day should not be a Bank Holiday throughout the said municipalities:

Now therefore I, the Governor of the State of Victoria, in the Commonwealth of Australia, by and with the advice of the Executive Council of the said State, and in pursuance of the powers conferred by section 7 of the Bank Holidays Act 1958, do by this my Proclamation declare that the said day shall not be a Bank Holiday throughout the said municipalities and appoint—Thursday, the twenty-second day of September, 1977, to be a Bank Holiday throughout the municipalities listed in the Second Schedule to the Bank Holidays Act 1958.

Given under my Hand and the Seal of the State of Victoria aforesaid, at Melbourne, this thirteenth day of September, in the year of our Lord, One thousand nine hundred and seventy-seven, and in the twenty-sixth year of the reign of Her Majesty Queen Elizabeth the Second, Queen of Australia.

(L.S.) HENRY WINNEKE

By His Excellency's Command,
VANCE DICKIE,
Chief Secretary

GOD SAVE THE QUEEN!

GOVERNMENT NOTICES

The Governor's Office,
Spring Street,
Melbourne, 3000,
2nd September, 1977

The Queen has been graciously pleased to signify Her Majesty's intention of conferring the following Honours in the Royal Victorian Order:—

ROYAL VICTORIAN ORDER

To be a Knight Commander of the Royal Victorian Order

His Excellency the Honourable Sir HENRY WINNEKE,
K.C.M.G., O.B.E., K.St.J., Q.C.

To be a Commander of the Royal Victorian Order

Mr. W. G. SMITH, C.M.G., M.V.O., O.B.E., O.St.J.

To be Members of the Royal Victorian Order (4th Class)

Mr. L. G. HOUSTON.
Mr. R. JACKSON, C.M.G., Q.P.M.

TOM FORRISTAL,
Official Secretary to the Governor

HOLIDAY—ROYAL AGRICULTURAL SHOW

Notice is hereby given that on—

THURSDAY, THE 22ND SEPTEMBER, 1977,

the Public Offices in the municipalities mentioned hereunder will be closed, that day being appointed by the Public Service Act 1974 to be observed as a holiday in the Public Offices:—

The Cities of Altona, Berwick, Box Hill, Brighton, Broadmeadows, Brunswick, Camberwell, Caulfield, Chelsea, Coburg, Collingwood, Croydon, Dandenong, Doncaster and Templestowe, Essendon, Fitzroy, Footscray, Frankston, Hawthorn, Heidelberg, Keilor, Kew, Knox, Malvern, Melbourne, Moorabbin, Mordialloc, Northcote, Nunawading, Oakleigh, Port Melbourne, Prahran, Preston, Richmond, Ringwood, St. Kilda, Sandringham, South Melbourne, Springvale, Sunshine, Waverley and Williamstown; the Shires of Bulla, Cranbourne, Diamond Valley, Eltham, Hastings, Lillydale, Melton, Mornington, Pakenham, Sherbrooke, Werribee and Whittlesea.

This notice relates only to the closing of the State Public Offices. All inquiries regarding holidays in other offices and in shops and industry should be directed to the Department of Labour and Industry, Industrial Information Service, 35 Spring Street, Melbourne, 3000. (Telephone 651 9111.)

VANCE DICKIE,
Chief Secretary

Chief Secretary's Office,
Melbourne, 29th August, 1977

Local Government Act 1958

NOTICE OF CONFIRMATION OF AN ORDER OF THE COUNCIL OF THE CITY OF SUNSHINE ADOPTING A PROPOSAL FOR THE CLOSURE OF STREET OR ROAD TO THROUGH TRAFFIC

Pursuant to the provisions of section 539c of the Local Government Act 1958, the Governor in Council, on the sixth day of September, 1977, confirmed an Order of the Council of the City of Sunshine made on 9th November, 1976, adopting a proposal for the closure of Warrs Road, Maribyrnong, to through traffic by the erection of a barrier at the location shown on the plan hereunder.

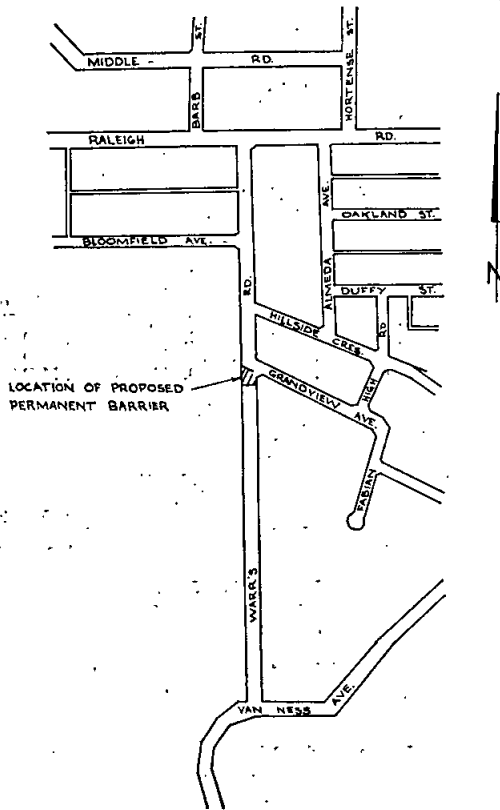

TOM FORRISTAL,
Clerk of the Executive Council

At the Executive Council Chamber,
Melbourne, 6th September, 1977.

LOCAL GOVERNMENT DEPARTMENT

ORDER CONFIRMED—CITY OF BERWICK

The Minister of the Crown administering the Local Government Act 1958, on the 9th day of September, 1977, confirmed an Order hereinafter referred to in pursuance of the provisions of section 514 of the said Act namely:—

An Order of the Council of the City of Berwick made on 5th July, 1977, directing the compulsory taking of the land described in Certificate of Title, Volume 8318, Folio 304 for the provision of a place of public resort for municipal and library purposes.

A. J. HUNT,
Minister for Local Government

Local Government Department,
Melbourne (77/3563)

LOCAL GOVERNMENT DEPARTMENT

ORDER CONFIRMED—CITY OF GEELONG

The Minister of the Crown administering the Local Government Act 1958, on the 9th day of September, 1977, confirmed an Order hereinafter referred to in pursuance of the provisions of section 514 of the said Act namely:—

An Order of the Council of the City of Geelong made on 20th July, 1977, directing the compulsory taking of the land described hereunder for the purpose of improving the locality by providing an allotment or allotments having not less than the minimum area or the minimum depth or width of frontage pursuant to the provisions of section 510 of the Local Government Act 1958:—

All that piece of land being part of Crown allotment 9, section 32B, City of Geelong, Parish of Corio, commencing at a point on the south-eastern side of Carr Place distance 28.96 metres from the south western side of McKillop Street; thence by a line bearing 101 deg. 0 min. distance 13.17 metres; thence by a line bearing 190 deg. 56 min. distance 18.55 metres; thence by a line bearing 281 deg. 11 min. distance 13.15 metres; and thence by a line bearing 10 deg. 53 min. distance 18.51 metres to the point of commencement.

A. J. HUNT,
Minister for Local Government

Local Government Department,
Melbourne (77/3782)

LOCAL GOVERNMENT DEPARTMENT

ORDER CONFIRMED—SHIRE OF BET BET

The Minister of the Crown administering the Local Government Act 1958, on the 9th day of September, 1977, confirmed an Order hereinafter referred to in pursuance of the provisions of section 514 of the said Act namely:—

An Order of the Council of the Shire of Bet Bet made on 24th August, 1977, directing the compulsory taking of certain land being Crown allotment 6, section 42, Town and Parish of Dunolly, County of Gladstone for road widening purposes.

A. J. HUNT,
Minister for Local Government

Local Government Department,
Melbourne (77/4677)

LOCAL GOVERNMENT DEPARTMENT

ORDER CONFIRMED—TOWN OF BAIRNSDALE

The Minister of the Crown administering the Local Government Act 1958, on the sixth day of September, 1977, confirmed an Order hereinafter referred to in pursuance of the provisions of section 514 of the said Act namely:—

An Order of the Council of the Town of Bairnsdale on 11th July, 1977, directing the compulsory taking of the land described in Certificate of Title Volume 8959 Folio 102 for the provision of a site to be made available to the Housing Commission of Victoria to build elderly citizens low rental housing.

A. J. HUNT,
Minister for Local Government

Local Government Department,
Melbourne (77/3613)

LOCAL GOVERNMENT DEPARTMENT

ORDER CONFIRMED—SHIRE OF RUTHERGLEN

The Minister of the Crown administering the Local Government Act 1958, on the sixth day of September, 1977, confirmed an Order hereinafter referred to in pursuance of the provisions of section 514 of the said Act namely:—

An Order of the Council of the Shire of Rutherglen made on 10th August, 1977, directing the compulsory taking of the land described in Certificate of Title Volume 3331 Folio 66 for the purpose of improving the locality by providing an allotment or allotments having not less than the minimum area or minimum depth or width of frontage pursuant to the provisions of section 510 of the Local Government Act 1958.

A. J. HUNT,
Minister for Local Government

Local Government Department,
Melbourne (76/5121)

Transport Regulation Act
TRANSPORT REGULATION BOARD
HEARING OF APPLICATIONS

Notice is hereby given that the following applications will be considered by the Transport Regulation Board on 4th October, 1977.

CROYDON BUS SERVICES PTY. LTD., Croydon. Application to license one commercial passenger vehicle with seating capacity for 27 persons to operate a demand responsive service between the Lilydale Railway Station and Shopping Centre and the area of Chirnside Park bounded by Beach Springs Road, Maroondah Highway, Victoria Road, Switchback Road, Edwards Road, Vista Drive, Songbird Avenue, due west to Anthony Street, Anthony Street and Joanne Avenue.

HOURS OF OPERATION

7 a.m. to 10 p.m.—Mondays to Fridays.

8 a.m. to 1 p.m.—Saturdays.

No service on Sundays or Public Holidays.

Fares.—To be determined.

HOLLAND, G. E., Avoca. Application to license one commercial passenger vehicle with seating capacity for 37 persons to operate as follows: (a) In substitution for, but not in addition to an existing licence T.S.319. (b) To undertake charter hirings from Avoca.

IOVANNELLA, Messrs. E. P. & P., North Melbourne. Application to license one commercial passenger vehicle with large seating capacity, to be purchased to operate as an additional metropolitan special service omnibus.

L. C. DYSON'S BUS SERVICE PTY. LTD., Reservoir. Application for variation of C.O. licence conditions on Route 562 (Regent—Whittlesea—Kingslake) to include the ability to:—(a) Undertake charter hirings from a 2-km radius of post offices at South Morang, Mernda, Yan Yean. (b) Undertake charter hirings from an 8-km radius of post offices at Kingslake, Kingslake West and Whittlesea.

PILLA, I. & BONO, J., Cheltenham. Application for variation of all existing M.O. licence conditions to delete Route 639 (Hampton—Southland) and instead to operate Route 638 (Hampton—Moorabbin) through to Southland Shopping Centre on a varied time-table as follows: Delete that part of Route 638 from the corner of Dane and Spring Roads, via Spring and Exley Roads and Henrietta Street and instead to operate from Spring Road via Dane Road, Nepean Highway, Station Street, Central Avenue to a stand to be located on the east side of Tuck Road. Service to then operate express to Southland via Redholme Street and Nepean Highway. On return trips to operate express to the Tuck Road Stand via Nepean Highway and Station Street and thence via Redholme Street, Nepean Highway and Dane Road to Spring Road and thence via the normal route.

POINT COOK—WERRIBEE PASSENGER, Werribee. Application to license one commercial passenger vehicle, to be purchased to operate as a Metropolitan Stage Omnibus between Werribee and Laverton commencing at the corner of Wedge and Watton Streets via Watton Street, Cherry Street, Princes Highway, Aviation Road, Maher Road, Bladin Street, Old Geelong Road, Fitzgerald Road, Leakes Road, Princes Highway, Westgate Bridge Highway, Millers Road; thence interchange with M.M.T.B. Buses. This service will connect with routes 436 (Hopper's Crossing—Werribee) and 438 (Werribee—Windermere) at the corner of Wedge and Watton Streets.

TIME-TABLE

60 minute frequency or as required.

Fares.—To be determined.

Special Conditions

On trips to Millers Road interchange—no passengers shall be picked up beyond the corner of Princes Highway and Leakes Road. On return trips, no passengers will be set down before the corner of Princes Highway and Leakes Road.

NOTE.—This application replaces the previous application gazetted on 26th November, 1969.

SURCH BUS SERVICES PTY. LTD., Sunshine. Application to license one commercial passenger vehicle with seating capacity for 25 persons to operate a demand responsive service between the St. Albans Railway Station and the area bounded by St. Albans Road, Leslie Street, Biggs Street, Stenson Road, Maribyrnong River and Taylor's Creek.

HOURS OF OPERATION

7 a.m. to 10 p.m.—Mondays to Fridays.

7 a.m. to 1 p.m.—Saturdays.

No service on Sundays and Public Holidays.

Fares.—To be determined.

ST. KILDA BUS SERVICE PTY. LTD., Port Melbourne. Application to license one commercial passenger vehicle with seating capacity for 49 persons to operate as a Metropolitan Special Service Omnibus.

Application for renewal of licences as shown by the persons listed hereunder to operate under the same terms and conditions:—

ANSETT TRANSPORT INDUSTRIES (OPERATIONS) PTY. LTD.: Melbourne; T.O.14, T.O.15, T.O.16, T.O.17, T.O.19, T.O.21, T.O.22, T.O.37, T.O.38, T.O.39, T.O.40, T.O.41, T.O.42, T.O.43, T.O.44, T.O.45, T.O.47, T.O.48, T.O.49, T.O.50, T.O.89, T.O.90, T.O.91, T.O.92, T.O.93, T.O.94, T.O.95, T.O.96, T.O.97, T.O.98, T.O.99, T.O.100, T.O.101, T.O.102, T.O.103, T.O.104, T.O.105, T.O.106, T.O.107 and T.O.108.

ANTANAKOPOULOS, N., North Balwyn; S.T.5638.

AUSTIN, D. G., Rosanna; S.T.5096.

BATTISTA, G., Blackburn; M.T.4552.

BENCE, E. J., Warrnambool; C.T.637.

BROWN, R. B., East Brunswick; S.T.7649.

COLE, S. J., Portarlington; S.T.7655.

CURNOW, J. R., West Coburg; M.T.1955.

DWYER, B. P., Mt. Waverley; M.T.5145.

EFSTATHIOU, P., Campbellfield; M.T.5060.

FLYNN, V., West Heidelberg; S.T.7864.

FORD MOTOR CO. OF AUST. PTY. LTD., Norlane; S.V.113.

GALANIS, P., Malvern; M.T.5089.

HEIB, K. A., Ashburton; S.T.7639.

HOLT, K. P., Burwood; S.T.5089.

IRWIN, I. R., Warrnambool; C.T.47.

KOUKOUNAS, G., Glen Iris; S.T.5792.

LIARAKOS, G., East Malvern; M.T.4867.

MELBOURNE—BRIGHTON BUS LINES PTY. LTD., Elwood; M.O.558, M.O.559, M.O.560, M.O.561, M.O.562, M.O.563, M.O.564, M.O.565, M.O.566, M.O.567, M.O.568, M.O.569, M.O.570, M.O.571, M.O.572, M.O.573, M.O.574, M.O.575, M.O.576, M.O.577, M.O.660, M.O.668, M.O.691, M.O.692, M.O.693 and M.O.694.

MOKDESSI, G. T., Altona; S.T.5713.

MUNRO, J. E., Ballarat; U.T.185.

NOLAN, L. G., Bentleigh; S.T.5100.

PUGLIESE, S., Springvale; M.T.4768.

RALSTON, Mrs. M. J., Nagambie; T.S.1341.

RUSSELL, K. S., Heathmont; S.T.7667.

SINCLAIR, W. & SON PTY. LTD., Murrumbeena; M.O.22, M.O.328, M.O.329, M.O.330, M.O.331, M.O.332, M.O.333, M.O.334, M.O.335, M.O.337, M.O.361, M.O.419, M.O.459 and M.O.492.

WEINSTEIN, M., Templestowe; M.T.5036.

Notice of any objections should be forwarded to reach the Secretary of the Board not later than 28th September, 1977.

Applicants are advised that it will not be necessary to appear on the hearing date specified, unless advised in writing by the Board.

H. SHEAHAN, Secretary

Corner Lygon and Princes Streets, Carlton, 3053,
Wednesday, 14th September, 1977.

Commercial Goods Vehicles Act
TRANSPORT REGULATION BOARD
HEARING OF APPLICATIONS

Notice is hereby given that the following applications will be considered by the Transport Regulation Board on 4th October, 1977.

A.R.C. ENGINEERING PTY. LTD., 528 Ballarat Road, Sunshine, 3020. One commercial goods vehicle (L/C. 16-70 tonne) to operate within a 40-km radius of the G.P.O. Melbourne and to Geelong and places on the Mornington Peninsula in the course of business as "Manufacturers of Steel Reinforcing and Welded Meshes"—own goods.

BLAKEY, N. C., 2 Mavista Avenue, Glen Waverley, 3170. One commercial goods vehicle (L/C. 7-10 tonne) to operate within a 112-km radius of the premises of The City Brickworks Co. at Malvern solely on behalf of the said company—bricks.

WILLIAM BOBY & Co. (AUST.) PTY. LTD., 44 Koornang Road, Scoresby, 3179. One commercial goods vehicle (L/C. 0-75 tonne) to operate throughout the State

- of Victoria in the course of business as "Water & Sewerage Treatment Engineers" for the purpose of servicing water and sewerage treatment plants—tools of trade, spare parts and materials incidental to on-site servicing.
- CASE, J. I., AUSTRALIA PTY. LTD.,** Princes Highway, Warragul, 3820. One commercial goods vehicle (L/C. 2.10 tonne and 3.50 tonne trailer) to operate within an 80-km radius of own branch premises at Warragul in the course of business as "Agricultural Implement Distributor"—own goods and machinery for repair or having been repaired.
- CLARK, J. & L., PTY. LTD.,** 24 Albion Street, Kyabram, 3620. One commercial goods vehicle (L/C. 3.80 tonne) to operate: (a) Between own subsidiary company stores trading as "Kings Tuckerbag" at Kyabram, Mooropna, Echuca and Bendigo—frozen foods. (b) From places within a 40-km radius of Kyabram to the Melbourne metropolitan area—fresh fruit and fresh vegetables but excluding the carriage of potatoes and onions. (c) From distributors or manufacturers in the Melbourne metropolitan area and within that part of the State of Victoria bounded on the east by a north/south line drawn through Mansfield and on the west by a north/south line drawn through Colac in the course of business as "Frozen Food Distributors" to own various retail stores at Kyabram, Mooropna, Echuca and Bendigo in a specially constructed refrigerated vehicle—frozen processed vegetables, frozen meats, frozen poultry, frozen fish, frozen prepared meals, chilled packaged fruit juices, cream, special soft cheese, yoghurt, dripping and lard, butter, margarine and cheese.
- NOTE.**—Butter and margarine is only to be carried from Melbourne as a mixed load when being carried with other frozen foods under refrigeration for distribution to retail stores and provided that the combined weight of butter and margarine carried does not exceed 3,000 kgs on any one load.
- CLARK'S COLDWAY PTY. LTD.,** 377 Bayswater Road, Bayswater, 3153. One commercial goods vehicle (L/C. 8.05 tonne) to operate throughout the State of Victoria in the course of business as "Frozen Food Distributors" in a specially constructed refrigerated vehicle—frozen poultry, frozen meat, frozen fish, frozen processed vegetables, ice-cream, frozen pastry lines, frozen cakes, frozen fruit juices up to 250 kgm of margarine and up to 250 kgm of Yoghurt.
- COOMBS, A. G., GROUP PTY. LTD.,** 26 Cochranes Road, Moorabbin, 3189. One commercial goods vehicle (L/C. 0.75 tonne) to operate throughout the State of Victoria in the course of business as "Heating Engineers"—tools of trade, spare parts and equipment incidental to the installation, servicing and maintenance of Air Conditioning units and heating systems.
- EMERY, D. C.,** Mitchell's Road, Jindivick, 3818. One commercial goods vehicle (L/C. 12.60 tonne) to operate: (a) Within a 64-km radius from the Quarry of Pakenham Blue Metal Pty. Ltd., at Pakenham—screenings and crushed rock. (b) Within a 32-km radius from the site of any construction or maintenance work performed pursuant to paragraph (a) above or from the railway station nearest thereto—any materials required for completion of such work.
- FAYLE, G. A.,** Broadford Road, Wandong, 3656. One commercial goods vehicle (L/C. 8.40 tonne and 11.80 tonne trailer) to operate: (a) Within an 80-km radius from the post office at Wandong—plant the property of a contractor and required by him for use in connection with the construction or maintenance of some specific, existing or proposed road, street, footpath, bridge, pier, wharf, weir or channel and also the following materials, viz. metal, stones, screenings, ashes, gravel, sand and earth. (b) Within a 32-km radius from the site of any construction or maintenance work performed pursuant to paragraph (a) above, or from the railway station nearest thereto—any other materials required for such work. (c) Within a 40-km radius of the Post Office at Wandong—general goods.
- FRASER, R. L.,** Buckmaster Drive, Mt. Evelyn, 3796. One commercial goods vehicle (L/C. 14.35 tonne) to operate: (a) Within a 40-km radius of own premises at Mt. Evelyn and to Frankston in the course of business as "Sand, Soil, Screenings and Garden Supplies"—own goods. (b) From Yea to own premises at Mt. Evelyn—own river pebbles. (c) From Beveridge and Diggers Rest to own premises at Mt. Evelyn—own scoria. (d) From Bacchus Marsh to own premises at Mt. Evelyn—own river pebbles and own sand.
- GARD, B. L.,** 4 Elizabeth Street, Ferntree Gully, 3156. One commercial goods vehicle (L/C. 5.05 tonne) to operate throughout the State of Victoria in the course of business as "Frozen Food Distributor" in a specially constructed refrigerated unit—frozen processed vegetables, frozen meat and ice-cream.
- GOOD ENGINEERING PTY. LTD.,** Valley Farm Road, Healesville, 3777. Application to vary the conditions of licence number D.A.67619/2 (L/C. 17.30 tonne) by adding an additional paragraph—"From Newport and Dandenong to own premises at Healesville and for distribution to places within a 32-km radius thereof in course of business as a "Petroleum Agent"—petroleum products and empty return containers.
- GREBE PTY. LTD.,** Lot 4 Albert Street, Warrnambool, 3249. Application to vary the conditions of licence numbers D.A.69322/3, D.A.69322/4 and D.A.69322/5 (L/C. 0.75, 2.95 and 3.85 tonne) by deleting existing conditions and adding in lieu—(a) Within that part of the State of Victoria bounded in the west by Dartmoor in the north by an east/west line drawn through Willaura and in the east by a north/south line drawn through Simpson as an "Agent" on behalf of Tarax Drinks Holdings Pty. Ltd.—aerated water and agency lines and empty return containers provided that all Tarax products other than bottled aerated water is initially consigned by rail to Warrnambool—(b) Within the area described in paragraph (a) in the course of business as an "Aerated Water Manufacturer" being an approved decentralized secondary industry—own manufactured aerated water and empty return containers. (c) Between Warrnambool and Horsham—own manufactured aerated waters in bottles and empty return containers".
- GREBE PTY. LTD.,** Lot 4 Albert Street, Warrnambool, 3249. Application to vary the conditions of licence No. D.A.69322/6 (L/C. 3.85 tonne) by deleting existing conditions and adding in lieu—(a) Within that part of the State of Victoria bounded on the north by an east/west line drawn through Hopetoun in the east by a north/south line drawn through St. Arnaud and in the south by an east/west line drawn through Maroona as an "Agent" on behalf of Tarax Drinks Holdings Pty. Ltd.—aerated water and agency lines and empty return containers provided that all Tarax products other than bottled aerated water is initially consigned by rail to Horsham. (b) Within the area described in paragraph (a) own manufactured bottled aerated water a product of Company's Warrnambool plant an approved decentralized secondary industry and empty return containers. (c) Between Horsham and Warrnambool empty returns returning with bottled aerated water from own plant at Warrnambool an approved decentralized secondary industry.
- GREENWAYS REFRIGERATED TRANSPORT PTY. LTD.,** Grant Road, Somerville, 3912. One commercial goods vehicle (L/C. 0.65 tonne) to operate throughout the State of Victoria in the course of business as "Frozen Food Distributors" as a service vehicle—tools of trade, spare parts and materials incidental to the on-site servicing and maintenance of own vehicles.
- JASHAR, A.,** Williams Road, Shepparton, 3630. Application to vary the conditions of licence No. D.A.69007 (L/C. 7.15 tonne) by deleting from paragraph (b) "Within an 80-km radius of the post office at Shepparton" and adding in lieu "Within that part of the State of Victoria bounded by straight lines through and joining Wodonga, Jamieson, Castlemaine and Swan Hill".
- JENNER, D. A.,** 6 Hill Street, Shepparton, 3630. One commercial goods vehicle (L/C. 1.00 tonne) to operate within that part of the State of Victoria bounded by a straight line drawn through and joining the towns of Cohuna, Kyneton, Jamieson, Mt. Beauty and then a north/south line to the border of Victoria and New South Wales in the course of business as "Pest Control Contractor"—tools of trade, equipment and chemicals necessary for the completion of own pest control contracts.
- JOHNS, E.,** 16 Belair Court, Bundoora, 3083. One commercial goods vehicle (L/C. 17.91 tonne) to operate under contract to A. R. Neal Pty. Ltd. Fairfield solely on behalf of Australian Paper Manufacturers Ltd. (a) Within a 40-km radius of Melbourne—raw materials and manufactured products. (b) From Melbourne to factories at Broadford and Maryvale—waste paper, incidental manufacturing materials and

- stores. (c) From factories at Broadford and Maryvale—finished and partly processed products, empty returns and machinery.
- LAKEY, K.**, corner Irelan and Polsue Streets, Maldon, 3463. One commercial goods vehicle (L/C. 11.10 tonne) to operate: (a) Within an 80-km radius from the post office at Maldon—plant the property of a contractor and required by him for use in connection with the construction or maintenance of some specific, existing or proposed road, street, footpath, bridge, pier, wharf, weir or channel and also the following materials, viz. metal, stones, screenings, ashes, gravel, sand and earth. (b) Within a 32-km radius from the site of any construction or maintenance work performed pursuant to paragraph (a) above, or from the railway station nearest thereto—any other materials required for such work. (c) Within a 40-km radius of the chief post office in Maldon—general goods.
- MASSEY FERGUSON (AUST.) LTD.**, 522 Princes Highway, Noble Park, 3174. Four commercial goods vehicles (L/C. 1.70, 1.35, 1.00 and 1.00 tonne) to operate throughout the State of Victoria in the course of business as "Earthmoving Sales and Service" for the purpose of servicing earthmoving and industrial machinery—tools of trade, spare parts and materials incidental to on-site servicing.
- MCCOSH, R. J.**, Mailors Flat, 3282. One commercial goods vehicle (L/C. 6.40 tonne) to operate: (a) Within an 80-km radius of own premises at Mailors Flat in the course of business as "Timber and Hardware Merchants"—own goods. (b) Goods associated with own approved decentralized secondary industry (prefabricated buildings, farm equipment and joinery) carried on at own premises at Mailors Flat as follows—(i) To the said premises at Mailors Flat from points within a 241-km radius of the said premises—raw materials required solely for use in the manufacturing processes of such approved decentralized secondary industry. (ii) From the said premises at Mailors Flat to points within a 241-km radius of the said premises—own manufactured joinery products and/or own prefabricated steel buildings, woolsheds, haysheds, gates and prefabricated sections of such buildings and sheds and also light welding work produced under contract in such approved decentralized secondary industry.
- NOTE.—Part (b) above shall be deemed not to extend to or relate to or authorize the carriage of or from Mailors Flat of any goods or agency lines associated with own retail department for resale purposes.
- MORELLI, P.**, 61 Morgan Street, Bairnsdale, 3875. One commercial goods vehicle (L/C. 18.40 tonne) to operate from Australian Paper Manufacturers Ltd. Pine forests at Stockdale and Longford to Pyneboard (Gippsland) Pty. Ltd. at Rosedale and to Australian Paper Manufacturers Ltd. at Maryvale—pulpwood.
- N. C. R. AUSTRALIA PTY. LTD.**, 23 Villiers Street, North Melbourne, 3051. Two commercial goods vehicles (L/C. 0.75 tonne each) to operate throughout the State of Victoria in the course of business as "Business Equipment Manufacturers" for the purpose of services and maintenance of office machines—tools of trade, spare parts and materials required for on-site servicing and maintenance of office machines, together with office machines for repair or having been repaired or for temporary loan.
- NEDIS PTY. LTD.**, Snakes Nest, Allingham Street, Kangaroo Flat, 3555. One commercial goods vehicle (L/C. 0.75 and 1.00 tonne trailer) to operate within a 120-km radius of own premises at Bendigo in the course of business as "Plumbers and Heating Appliance Installing and Servicing Contractors"—tools of trade, materials and equipment incidental to completion of own contracts.
- NEILL, J.**, 46 Hamilton Street, Broadford, 3658. One commercial goods vehicle (L/C. 9.50 tonne) to operate within an 80-km radius of Avenel on behalf of Pioneer Concrete (Vic.) Pty. Ltd. in a specially constructed agitator vehicle—premixed concrete on behalf of the said company.
- O'CONNOR, A. B. (M.D.A.) PTY. LTD.**, 125 Lime Avenue, Mildura, 3500. One commercial goods vehicle (L/C. 0.50 and 0.80 tonne trailer) to operate: (a) Within an 80-km radius of the post office at Mildura in the course of business as "Monumental Mason"—tools of trade and materials incidental to the completion of the erection and installation of monuments. (b) Throughout the State of Victoria in the course of business as "Funeral Directors"—as a mortuary vehicle.
- PRIDHAM, W. (AUST.) PTY. LTD.**, 11 Evans Street, Braybrook, 3019. One commercial goods vehicle (L/C. 9.65 tonne) to operate: (a) Within an 80-km radius of own premises at Braybrook in the course of business as "Meat Meal, Tallow and Casing Manufacturers"—own goods (other than restricted goods which may be specified by notice in the *Government Gazette* from time to time). (b) Throughout the State of Victoria for collection from country abattoirs, butchers and killing centres for return to own premises at Braybrook—offal, bones, animal runners and waste materials, excluding tallow. (c) Within an 80-km radius of own premises at Braybrook in the course of business as "Meat Meal, Tallow and Casing Manufacturers" for collection from butchers and abattoirs—meat meal, tallow and semi-processed tallow and protein meal.
- TRANS OTWAY LTD.**, corner Ryrle and Fenwick Streets, Geelong, 3200. One commercial goods vehicle (L/C. 15.15 tonne) to operate: (a) For the carriage of general goods from and to the Metropolitan area (as defined in the *Transport Regulation Act 1958*) and/or from and to the Geelong District (as defined in the Second Schedule of the *Commercial Goods Vehicles Act 1958*) to and from any of the following places namely—(i) Places outside a 13-km radius of the chief post office in the City of Geelong situated along or accessible from the Geelong-Torquay Road or the Waurin Ponds-Anglesea Road. (ii) Places on or accessible only from the Great Ocean Road between and including the townships of Torquay and Apollo Bay. (iii) Places within an 8-km radius of the post office at Lorne. (iv) Places within a 16-km radius of the post office at Apollo Bay. (b) From and to the Township of Apollo Bay to and from the City of Colac. (c) Within a 32-km radius of the post office at Apollo Bay. (d) Within a 40-km radius of the chief post office in the City of Geelong. (e) From and to the Township of Lorne to and from the City of Colac. (f) Within a 32-km radius of the post office at Lorne. (g) From and to places situated within a 40-km radius of the G.P.O. Melbourne and from places situated within that part of an 80-km radius of the G.P.O. Melbourne bounded on the east by a north/south line drawn through the City of Melbourne and on the north by an east/west line drawn through the City of Melbourne for the carriage of goods (other than restricted goods which may be specified by notice in the *Government Gazette* from time to time).
- WALDMANIES, H.**, 37 Strickland Road, Bendigo, 3550. One commercial goods vehicle (L/C. 0.50 tonne and 2.00 tonne trailer) to operate throughout the State of Victoria in the course of business as "Swimming Pool Installation Contractor" for the purpose of installing and servicing swimming pools and associated equipment—tools of trade, swimming pool equipment for specialized installation and materials incidental to the completion of own contracts.
- WARREN, R. W.**, 35 Perring Street, Robinvale, 3549. One commercial goods vehicle (L/C. 2.75 tonne) to operate: (a) Throughout the State of Victoria for the carriage of household furniture; being furniture or personal effects of the householder or a member of his family when such goods are being moved—(i) from residence to residence; (ii) from residence for storage or for sale; (iii) from storage to residence; (iv) from vendor to the residence of the purchaser. (b) From Melbourne to Mildura, Robinvale and places en route—(i) new furniture as per Transport Roads Board new furniture schedule; (ii) secondhand office machines and office furniture; (iii) secondhand household furniture and household equipment including secondhand refrigerators, washing machines, sewing machines, inner-spring mattresses, from auction rooms, to shop and from secondhand shop to secondhand shop; (iv) goods as described in paragraph (b) (i), (b) (ii) and (b) (iii) being returned to Melbourne from Mildura and Robinvale and towns en route under direction of retailing organizations to whom goods were first delivered (damaged, superseded and stock transfer)—glazed windows; (v) between own stores situated at Mildura and Robinvale—stock transfers.
- WESTINGHOUSE, ELECTRIC AUSTRALIA LTD.**, 46 Oxford Street, Collingwood, 3066. One commercial goods vehicle (L/C. 0.75 tonne and 1.50 tonne trailer) to operate throughout the State of Victoria in the course of business as an "Electrical Engineering Service Organization" for the purpose of servicing electrical equipment and components—tools of trade, spare parts and materials incidental to on-site servicing.

WHELAN, D. A., Swan Reach, 3903. One commercial goods vehicle (L/C. 7.00 tonne approximately) to operate: (a) Within a 152-km radius of the post office at Nowa Nowa (Bairnsdale Division of the Country Roads Board) plant the property of a contractor and required for use in connection with the construction or maintenance of some specific, existing or proposed road, street, footpath, bridge, wharf, pier, weir or channel. (b) Within a 32-km radius from site of construction or maintenance work performed, pursuant to paragraph (a) above or from the railway station nearest thereto—metal, stones, screenings, ashes, gravel, sand, earth and any other materials required for such work. (c) Within a 40-km radius of the post office at Swan Reach—general goods.

WHITEHEAD, W. J., R.S.D. Grasmere, 3282. One commercial goods vehicle (L/C. 13.50 tonne) to operate: (a) Within a 40-km radius of Grasmere Junction—general goods. (b) Within an 80-km radius of Grasmere Junction in the course of business as "Drainage Contractor and Supplier of Drainage Materials"—own goods.

WILSON, R. H., 67 Main Street, Bairnsdale, 3875. One commercial goods vehicle (L/C. 1.50 tonne) to operate within an 80-km radius of the post office at Bairnsdale and/or within that part of the State of Victoria east of a line drawn due north and south through the City of Bairnsdale in the course of business as "Retail and Wholesale Bearing Supplies"—own goods.

RENEWALS

Application for renewal of licences as shown by persons listed hereunder to operate under the same terms and conditions from the expiry shown in each case.

BUTCHER, J. W. (trading as Anakie Brick Co.), Main Road, Anakie, 3221; D.A.62771/1; 22nd October, 1977; 6.65 tonne.

ANDERSON, I. G., 4/63 Donne Street, West Coburg, 3058; D.A.63138; 6th October, 1977; 9.35 tonne.

BORGO, M., 14 Arthur Street, Preston, 3072; D.A.38873; 14th October, 1977; 1.45 tonne.

BRUNDELL, D. J., 278 Bell Street, Preston, 3072; D.A.66392; 22nd October, 1977; 6.75 tonne.

COLCOTT & STEPHENS PTY. LTD., 41 Hedderwick Street, Essendon, 3046; D.A.8164; 19th October, 1977; 1.00 tonne.

CONTAINER TRANSPORT CO. PTY. LTD., Victoria Drive, West Footscray, 3012; D.A.64832/11; 22nd October, 1977; 3.70 tonne.

HUMPHREY, K. V. (trading as Cressy Spraying Service), 28 New Station Street, Cressy, 3322; D.A.61681/1; 27th October, 1977; 0.85 tonne and 1.50 tonne trailer.

CYCLONE K.-M. PRODUCTS PTY. LTD., Cremorne Street, Richmond, 3121; T.D.A.51030/8; 18th October, 1977; 1.25 tonne.

DEVERY, L. V., Tarravongee, via Wangaratta, 3677; D.A.66356; 1st October, 1977; 7.50 tonne.

HAJEK, P., Whorouly, 3735. D.A.63194; 27th October, 1977; 0.50 tonne.

LLEWELLYN, K. C., 73 Sandells Road, Tecoma, 3160; D.A.66420; 29th October, 1977; 10.10 tonne.

MAJOR BUILDING SERVICE PTY. LTD., 27 McArthur Road, Altona North, 3025; D.A.56523/10; 29th October, 1977; 1.00 tonne.

MORSE, JACK, ENGINEERING PTY. LTD., 130 Lava Street, Warrnambool, 3280; D.A.66410; 15th October, 1977; 1.40 tonne.

POULSTON, R. & R. A., 67 Bridge Street, Bendigo, 3550; D.A.44662/1; 18th October, 1977; 0.75 tonne.

PRITCHARD, G. E., 6 Brophy Street, Ballarat, 3350; D.T.1350; 13th October, 1977; 11.85 tonne.

REPCO LTD., C/O REPCO AUTO PARTS (VIC.), 618-640 Elizabeth Street, Melbourne, 3000; D.A.68791/24; 18th October, 1977; 1.10 tonne; D.A.68791/25; 14th October, 1977; 0.75 tonne.

SIDES, W. L., & SON PTY. LTD., 168 Wellington Road, Clayton, 3168; D.A.38601/14; 9th October, 1977; 0.70 tonne.

WALSH, B. F. (trading as Stacey & Walsh), McGeehan Crescent, Myrtleford, 3737; D.A.68645; 7th November, 1976; 1.95 tonne.

STACEY, O. A. (trading as Stacey & Walsh), McGeehan Crescent, Myrtleford, 3737; D.A.68644; 7th November, 1976; 7.00 tonne.

STACEY, O. A., McGeehan Crescent, Myrtleford, 3737; D.A.68644/1; 7th November, 1976; 3.15 tonne.

STALKER, D. J., Mount Egerton, 3345; D.A.66987; 18th October, 1977; 3.90 tonne.

STEVENS, J. R., 4 Oak Grove, East Malvern, 3145; D.A.63130; 22nd September, 1977; 0.50 and 0.75 tonne trailer.

WALKER, K. J., 716 Gregory Street, Ballarat, 3350; D.A.63006; 8th September, 1977; 1.60 tonne.

TOW TRUCKS

H. & R. MOTOR SERVICE, 162 Thistlethwaite Street, South Melbourne, 3205; D.A.57211; 18th October, 1977; 1.60 tonne.

TIMMS, J. R. W., 55 Lonsdale Street, Dandenong, 3175; D.A.63008; 13th October, 1977; 3.95 tonne.

M. R. W. PTY. LTD., 3 Comley Street, North Sunshine, 3020; D.A.44494/2; 16th October, 1977; 2.70 tonne.

M. R. W. PTY. LTD., 2 Williamstown Road, West Footscray, 3012; D.A.44494; 17th September, 1977; 1.90 tonne.

Notice of any objection should be forwarded to reach the Secretary of the Board not later than 28th September, 1977.

Applicants are advised that it will not be necessary to appear on the hearing date specified above, unless advised in writing by the Board.

H. SHEAHAN, Secretary

Corner Lygon and Princes Streets, Carlton, 3053, Wednesday, 14th September, 1977.

DEPARTMENT OF MINERALS AND ENERGY

AREAS OF EXPLORATION LICENCES REDUCED

No. 528; Western Mining Corporation Limited; reduced from 528 km² to 198 km² comprising Graticular Block Nos. 1298, 1370 and 1442 Melbourne Map Sheet.

No. 529; Western Mining Corporation Limited; reduced from 528 km² to 198 km² comprising Graticular Block Nos. 1294, 1365 and 1366 Hamilton Map Sheet.

EXTRACTIVE INDUSTRY LICENCES GRANTED

No. 812; Eric John Gallpen, Margaret Lenora Gallpen; 7.8 ha, Parish of Trewalla.

No. 829; Anne Maree Gillett, Robert Leslie Gillett, Betty Gillett, Eric Wilfred Gillett, Neil John Gillett, Alan Wilfred Gillett; 63 ha, Parish of Gorong.

JIM BALFOUR,

Minister for Minerals and Energy

Pipelines Act 1967

NOTICE OF VARIATION OF CONDITIONS OF A PIPELINE LICENCE

Whereas sub-section (3) of Section 30 of the Pipelines Act 1967 provides that the Minister may by notice published in the Government Gazette amend, vary, add to or revoke any condition stated or included in a licence, I, James Charles Murray Balfour, Minister of Mines do now hereby vary the conditions of Pipeline Licence No. 46 in the manner indicated in the Schedule hereto:—

SCHEDULE

Amend Clause I (C) of the Schedule to the licence to read as follows:—

(iii) Meter Station

5 x 16 in., and 3 x 10 in. positive displacement meters shall be installed down-stream of the pumping units referred to in Clause G of the Schedule in accordance with the details shown on Drawing No. 254—MF1—5 accompanying the application.

Dated this 26th day of August, 1977

J. C. M. BALFOUR, Minister of Mines

Cattle Compensation Act 1967 (No. 7615)

APPROVED AGENT

NOTICE UNDER SECTION 14

I hereby declare Corio Meat Packing (1965) Pty. Ltd. trading as Jacksons Corio Meat Packing (number 102 in the register) being a person carrying on business as a stock and station agent, to be an "Approved Agent" for the purposes of Part II. of the Cattle Compensation Act 1967, with effect from Saturday 1st October 1977.

R. M. PHIBBS,
Comptroller of Stamps

Stamp Duties Office,
Melbourne, 14th September, 1977

Private Agents Act 1966

NOTICE OF RECEIPT OF APPLICATIONS FOR LICENCES UNDER THE PROVISIONS OF THE PRIVATE AGENTS ACT 1966

The Clerk(s) of the Magistrates' Court(s) as listed hereunder hereby give notice that applications, as under, have been lodged for hearing by the said Court(s) on the date(s) specified.

Any person desiring to object to any of such applications must—

- (a) lodge with the respective Clerk of the Magistrates' Court a notice in the prescribed form of his objection and of the grounds thereof;
- (b) cause a copy of such notice to be served personally or by post upon the applicant at least three days before the hearing of the application; and
- (c) send or deliver—
 - (i) where the objection is not made by the officer in charge of the police district in which the Court is situated—a copy of the notice to such officer; and
 - (ii) where the objection is not made by the Registrar or Deputy Registrar—a copy to the Registrar.

Full Name of Applicant or in the Case of a Firm or Corporation, of the Nominee	Place of Abode of Applicant or Nominee	Name of Firm or Corporation	Address for Registration	Type of Licence	Date of Hearing of Application
--	--	-----------------------------	--------------------------	-----------------	--------------------------------

MAGISTRATES' COURT, PORT MELBOURNE

Matthews, Robert John	6/21 Roydon Street, Moorabbin	Armaguard	117 Dow Street, Port Melbourne	Watchman	13.10.77
-----------------------	-------------------------------	-----------	--------------------------------	----------	----------

Dated at Port Melbourne this 2nd day of September, 1977

R. J. MCHUGH, Clerk of the Magistrates' Court

MAGISTRATES' COURT, OAKLEIGH

White, Lawrence	18 Bellevue Road, East Bentleigh	Argus Night Patrol	19A Portman Street, Oakleigh	Watchman	14.10.77
-----------------	----------------------------------	--------------------	------------------------------	----------	----------

Dated at Oakleigh this 2nd day of September, 1977

S. JANSON, Clerk of the Magistrates' Court

MAGISTRATES' COURT, COBURG

Claxton, Raymond John	11 Seston Street, Reservoir	Mayne Nickless Ltd.	94 York Street, South Melbourne	Watchman	21.9.77
Bean, Francis Leonard	8 Headley Street, North Coburg	" "	" "	"	28.9.77
Kitchell, Adrian Joseph	29 Moreton Crescent, Bundoora	" "	" "	"	"

Dated at Coburg this 2nd day of September, 1977

B. T. MANSBRIDGE, Clerk of the Magistrates' Court

MAGISTRATES' COURT, RINGWOOD

Atkinson, Donald Robert	53 Newlands Road, Coburg	Smiths Mercantile Agency	Unit 4, 1 Dornoch Court, Croydon	Commercial Sub-Agent	23.9.77
-------------------------	--------------------------	--------------------------	----------------------------------	----------------------	---------

Dated at Ringwood this 2nd day of September, 1977

L. GOULD, Clerk of the Magistrates' Court

MAGISTRATES' COURT, ST. KILDA

Lindsay, Peter Raymond	12/82 Park Street, West St. Kilda	" "	21/285 Carlisle Street, Balaclava	Process Server	4.10.77
Lindsay, Peter Raymond	" "	" "	" "	Inquiry Agent	"

Dated at St. Kilda this 6th day of September, 1977

B. J. CLOTHIER, Clerk of the Magistrates' Court

MAGISTRATES' COURT, BRUNSWICK

O'Connor, Ilga Lydia Berta	72 Coonans Road, Pascoe Vale South	" "	21 Appleby Crescent, West Brunswick	Process Server	3.10.77
----------------------------	------------------------------------	-----	-------------------------------------	----------------	---------

Dated at Brunswick this 5th day of September, 1977

R. WILSON, Clerk of the Magistrates' Court

MAGISTRATES' COURT, WARBURTON

Bowie, Robert James	Lot 296 Alpine Boulevard, Launching Place	" "	Lot 296 Alpine Boulevard, Launching Place	Process Server	5.10.77
Sutherland, Robert James	Lot 131 Cairncroft Avenue, Launching Place	" "	24 Eureka Street, Richmond	Watchman	"

Dated at Warburton this 7th day of September, 1977

B. DOBSON, Clerk of the Magistrates' Court

MAGISTRATES' COURT, WODONGA

Isodora, John William	546 Hanel Street, Albury	" "	94 York Street, South Melbourne	Watchman	27.9.77
-----------------------	--------------------------	-----	---------------------------------	----------	---------

Dated at Wodonga this 5th day of September, 1977

L. P. BYRNE, Clerk of the Magistrates' Court

MAGISTRATES' COURT, CAMBERWELL

Haughton-Wyatt, Thomas Francis	51 Dover Street, Richmond	" "	Villa 1, 1 Maverston Street, Burwood	Process Server	28.9.77
--------------------------------	---------------------------	-----	--------------------------------------	----------------	---------

Dated at Camberwell this 7th day of September, 1977

J. M. WALSH, Clerk of the Magistrates' Court

PRIVATE AGENTS—continued

Full Name of Applicant or in the Case of a Firm or Corporation, of the Nominee	Place of Abode of Applicant or Nominee	Name of Firm or Corporation	Address for Registration	Type of Licence	Date of Hearing of Application
MAGISTRATES' COURT, SALE					
Cameron, Ronald John	Yuill Road, Sale	Wormald International Security	340 Abbotsford Street, North Melbourne	Watchman	20.9.77
Dated at Sale this 29th day of August, 1977					
A. DUNLOP, Clerk of the Magistrates' Court					
MAGISTRATES' COURT, FRANKSTON					
Hanger, John Robertson	10 Crathie Court, Frankston		10 Crathie Court, Frankston	Process Server	6.10.77
Hanger, John Robertson	" " "		" " "	Inquiry Agent	"
Hanger, John Robertson	" " "		" " "	Guard Agent	"
Dated at Frankston this 8th day of September, 1977					
D. J. DEVLIN, Clerk of the Magistrates' Court					
MAGISTRATES' COURT, CHELSEA					
Hassell, Robert	380 Nepean Highway, Chelsea		380 Nepean Highway, Chelsea	Commercial Sub-Agent	3.10.77
Dated at Chelsea this 7th day of September, 1977					
W. A. WARD, Clerk of the Magistrates' Court					
MAGISTRATES' COURT, FOOTSCRAY					
Holland, Robert Alexander	15 Finley Road, Altona		4 Cross Street, Footscray	Watchman	14.10.77
Dated at Footscray this 8th day of September, 1977					
R. BRUGGEMAN, Clerk of the Magistrates' Court					
MAGISTRATES' COURT, SPRINGVALE					
Osborne, Brian Leonard	1 Mimosa Street, Doveton	Southern Securities	Star 173 Springvale Road, Springvale	Watchman	30.9.77
Dated at Springvale this 8th day of September, 1977					
P. COUTTS, Clerk of the Magistrates' Court					
MAGISTRATES' COURT, FOOTSCRAY					
Larsen, Erik	18 McCubbin Court, Sunbury		2 Coode Road, West Melbourne	Watchman	14.10.77
Dated at Footscray this 9th day of September, 1977					
R. BRUGGEMAN, Clerk of the Magistrates' Court					
MAGISTRATES' COURT, PORT MELBOURNE					
Pollock, Anthony James	34/16A Chapel Street, St. Kilda	Armguard	117 Dow Street, Port Melbourne	Watchman	25.10.77
Dated at Port Melbourne this 9th day of September, 1977					
R. J. MCHUGH, Clerk of the Magistrates' Court					

**KYABRAM WATER AUTHORITY
EXCESS WATER BY-LAW NO. 5**

The Kyabram Water Authority in pursuance of and in exercise of the powers conferred by the Water Act 1958 and of any and every other power it thereunto enabling doth make a By-Law as follows:—

1. The meter or meters measuring the supply of water to any land or tenement shall be read as near as practicable to twelve months from the date that it was read previously and the quantity of water so measured as having been supplied during the period between any two successive such readings (hereinafter called "the meter year") shall be the basis of the calculating of charges payable under this By-Law provided always that where a meter has been installed on any land or tenement during the course of the meter year the quantity of water measured as having been supplied during the period between the date of such installation and the date of the reading shall be the basis of calculating such charges.

2. Subject as hereinafter provided in respect of any land or tenement rated by the Authority.

(a) The maximum quantity of water to be supplied in any meter year without charge is hereby fixed as a quantity which if charged at 6.05 cents per kilolitre for any meter year would give an amount equal to the amount of the rate payable in respect of the land or tenement for the financial year in which the said meter year ended.

(b) For all water supplied in any meter year in excess of the maximum quantity referred to in paragraph (a) of this clause the charge is hereby fixed at 6.05 cents per kilolitre.

3. Subject as hereinafter provided the charge for water supplied by measure to any property not rated by the Authority is hereby fixed at 6.05 cents per kilolitre.

4. The Minimum charge for water supplied by measure to any property not rated by the Authority is hereby fixed at Twenty-Five Dollars.

5. The aforesaid charges shall be payable within seven days of demand upon the owners or occupier at the Office of the Authority during normal business hours.

6. The aforesaid charges shall apply as from the first day of October, 1977.

7. The provisions of clauses 2, 3, and 4, of this By-Law, shall not apply to any land tenement or property supplied with water by the Authority under a special agreement pursuant to Section 215 of the Water Act 1958.

8. Excess Water By-Law No. 4 is hereby repealed.

Passed this 9th day of August, 1977

(SEAL) V. N. T. KUHLE, Chairman
K. W. ANDREWS, Member
E. T. CORNISH, Secretary

Approved, 29th August, 1977—F. J. GRANTER, Minister of Water Supply.

**CHARLTON WATERWORKS TRUST
INCREASING THE LIMIT OF BANK OVERDRAFT**

His Excellency the Governor of the State of Victoria by and with the advice of the Executive Council thereof doth by Order made on the 13th day of September, 1977, increase the total amount of the sums which the Charlton Waterworks Trust may owe at any one time in respect of moneys borrowed by overdraft of current account pursuant to the provisions of section 288 of the Water Act 1958, fixed by the Governor in Council on 10th December, 1977, at Ten thousand dollars (\$10,000), to One hundred thousand dollars (\$100,000).

TOM FORRISTAL,
Clerk of the Executive Council
At the Executive Council Chamber,
Melbourne, 13th September, 1977

DAYLESFORD SEWERAGE AUTHORITY

FIXING THE LIMIT OF BANK OVERDRAFT

His Excellency the Governor of the State of Victoria by and with the advice of the Executive Council thereof doth by Order made on the 13th day of September, 1977, fix the total amount of the sums which the Daylesford Sewerage Authority may owe at any one time in respect of moneys borrowed by overdraft of current account pursuant to the provisions of section 79 of the *Sewerage Districts Act 1958* at One hundred and fifty thousand dollars (\$150,000).

TOM FORRISTAL,
Clerk of the Executive Council

At the Executive Council Chamber,
Melbourne, 13th September, 1977

YATCHAW DRAINAGE TRUST

FIXING THE LIMIT OF BANK OVERDRAFT

His Excellency the Governor of the State of Victoria by and with the advice of the Executive Council thereof doth by Order made on the 13th day of September, 1977, fix the limit of the amounts which the Yatchaw Drainage Trust may owe at any one time in respect of moneys borrowed by overdraft of current account with a bank pursuant to the provisions of section 42A of the *River Improvement Act 1958* at six thousand dollars (\$6,000).

TOM FORRISTAL,
Clerk of the Executive Council

At the Executive Council Chamber,
Melbourne, 13th September, 1977

DRAINAGE AREAS ACT

SPECIAL MAINTENANCE CHARGE MADE BY THE COUNCIL OF THE SHIRE OF SOUTH GIPPSLAND IN RESPECT OF THE CORNER INLET DRAINAGE AREA

Notice is hereby given that on the sixth day of September, 1977, in accordance with the provisions of section 36 of the *Drainage Areas Act 1958*, the Governor in Council approved of the estimate of the cost of proposed maintenance works in the Corner Inlet Drainage Area submitted by the Council of the Shire of South Gippsland, and of the making by the Council of a Special Maintenance Charge on properties within the said Drainage Area, for the year ending 30th June, 1977.

TOM FORRISTAL,
Clerk of the Executive Council

At the Executive Council Chamber,
Melbourne, 6th September, 1977.

Police Offences Act 1958, No. 6337

DIVISION 1A—STATE ADVISORY BOARD ON PUBLICATIONS

Whereas I have considered reports made to me by the State Advisory Board on Publications under section 180D (2) (a) of the *Police Offences Act*:

I, Vance Oakley Dickie, Chief Secretary for the State of Victoria, in pursuance of the power vested in me by section 180H (1) of the *Police Offences Act* hereby determine that the following publications prescribed by title in the Schedule hereunder shall be classified as restricted publications for the purpose of the abovenamed Act:

SCHEDULE OF PUBLICATIONS

Title	Distributor
A Guide To Growing Cannabis Under Fluorescents	Melbourne Wholesale Newsagency Pty. Ltd.
A Night At The Baths—Show Hard No. 6	Pervada Fleur Pty. Ltd.
Béavers In Uniform Vol. 4 No. 4	Kennard International Pty. Ltd.
Bound To Serve No. 7	Pervada Fleur Pty. Ltd.
Chicken Tricks	Pervada Fleur Pty. Ltd.
Cloud 9 Vol. 6 No. 1	Melbourne Wholesale Newsagency Pty. Ltd.
Club International Vol. 6 No. 7	Kennard International Pty. Ltd.
Coffee N' Cream	Wathen Wholesale Pty. Ltd.
Color Climax No. 5	Pervada Fleur Pty. Ltd.
Crack Vol. 3 No. 2	Kennard International Pty. Ltd.

Title	Distributor
Discipline & Desire Vol. 3 No. 4	Kennard International Pty. Ltd.
Drug Manufacturing For Fun And Profit	Melbourne Wholesale Newsagency Pty. Ltd.
Eve's Rib No. 1	Melbourne Wholesale Newsagency Pty. Ltd.
Exposure And Design No. 13	Melbourne Wholesale Newsagency Pty. Ltd.
Far Out Comix	Melbourne Wholesale Newsagency Pty. Ltd.
Frenzy Vol. 2 No. 3	Pervada Fleur Pty. Ltd.
Fucking Couples Vol. 1 No. 1	Melbourne Wholesale Newsagency Pty. Ltd.
Gay No. 36	W. J. Horne
Genesis—September 1977	Kennard International Pty. Ltd.
Him Exclusive — Black Studs No. 1	Wathen Wholesale Pty. Ltd.
Hip Chicks No. 2	Melbourne Wholesale Newsagency Pty. Ltd.
Kingsize International Vol. 8 No. 2	Kennard International Pty. Ltd.
Ladies Of Vice	Magazine Imports Pty. Ltd.
Leggy Lovelies No. 32	Kennard International Pty. Ltd.
Love-In	Wathen Wholesale Pty. Ltd.
Man-Handler	Pervada Fleur Pty. Ltd.
Modern Adonis No. 50	Wathen Wholesale Pty. Ltd.
Movie Mansion Madness	Kennard International Pty. Ltd.
New Cunts No. 15	Venus Enterprises Pty. Ltd.
Pictorial Sexpress Vol. 1 No. 3	Melbourne Wholesale Newsagency Pty. Ltd.
Pinning A Stud	Melbourne Wholesale Newsagency Pty. Ltd.
Playbirds Erotic Film Guide No. 1	Claredale Trading Pty. Ltd.
Pleasure No. 8	Venus Enterprises Pty. Ltd.
Pub—September 1977	Kennard International Pty. Ltd.
Pussycat Vol. 1 No. 1	Melbourne Wholesale Newsagency Pty. Ltd.
Revolt Gallery	Wathen Wholesale Pty. Ltd.
Ribald No. 250	W. J. Horne
Searchlight No. 225	Melbourne Wholesale Newsagency Pty. Ltd.
Sex Fantasies Vol. 8 No. 1	Kennard International Pty. Ltd.
Sex Primer No. 2	Melbourne Wholesale Newsagency Pty. Ltd.
Sexy Swingers No. 229	Pervada Fleur Pty. Ltd.
Sting Vol. 3 No. 3	Kennard International Pty. Ltd.
Stolen Sweets Vol. 8 No. 2	Kennard International Pty. Ltd.
Teenage Nudist Nos. 20, 21 & 22	Melbourne Wholesale Newsagency Pty. Ltd.
The Pot Book	Melbourne Wholesale Newsagency Pty. Ltd.
Tri Con Brio	Wathen Wholesale Pty. Ltd.
Vigour! International Vol. 1 No. 1	Wathen Wholesale Pty. Ltd.

VANCE DICKIE,
Chief Secretary

Chief Secretary's Office,
Melbourne, 13th September, 1977

Police Regulation Act 1958, Section 122
SALE OF UNCLAIMED MOTOR VEHICLE

An owner is required for a 1956 model yellow Volkswagen kombi van, ex-Registered No. GMC-250.

The vehicle came into the possession of Police on 15th September, 1976, and if unclaimed will be sold by public auction at the St. Albans Police Station, 36-38 Main Road West, St. Albans, at 2.00 p.m. on Wednesday, 12th October, 1977.

5th September, 1977

S. I. MILLER,
Chief Commissioner

STOCK DISEASES ACT 1968

In pursuance of section 32 (1) of the *Stock Diseases Act 1968*, the name and address of owners of properties, together with the name and location of properties within the footrot control area which are at present under quarantine or under restrictions, because of footrot, are listed below.

Name	Address	Farm Location
Beaton, N. D.	Gritjurk via Coleraine	Gritjurk
Burns, G. (estate of)	Casterton	Nangeela
Cameron, N. L. and Son	"Fernleigh", Toolondo	Toolondo and Nurrabiel
Cannon, Mrs. E. I.	Condah	Condah
Chaston, T. D. and A. J.	"Kanya", Apsley	Benayeo
Clark, J. (estate of)	"Wywurre", Branxholme	Ardachy
Colliver, B. W.	Box 145, Heywood	Etrrick Road, Heywood
Cranage, G. J. and P. J.	Box 72, Edenhope	Edenhope
Crowhurst, A.	"Halstead", Harrow	Chetwynd
Dawson, P. B. and P. I.	Box 523, Naracoorte	"Stranraer", Langkoop
Ferrier, P. D.	Kadnook via Harrow	Kadnook
Fidler, T. and W.	Box 117, Merino	"Wymtom", Merino
Field, H. J.	63 Blair Street, Portland	Etrrick Road, Condah
Forster, J. M.	R.M.B. 418, Edenhope	"Mossgiel", Patyah
Forster, K. E. and J.	R.M.B. 430, Edenhope	Patyah
Foster, C. J.	Box 174, Casterton	"Southdene", "Oakvale", Corn- dale
Futerieal, J.	Chetwynd East Road, Chetwynd	"Athlone", Chetwynd
Glenbrook Partnership	Tarrington	"Glenbrook", Tarrington
Hadden, A.	R.M.B. 536, Casterton	"Avondale", Chetwynd
Harvey, W. T. and Co.	Box 178, Casterton	"Lindsay", Strathdownie
Hayes, L. R.	Branxholme	"Lynvale", Hayes Lane, Branx- holme
Healy, P. V.	Henty Highway, Mooralla	Mooralla
Jeffries, C. J.	R.S.D. Condah	"Kentucky", Condah
Kalabity Traders	Casterton	"Barnoolut", Wando Bridge
King, C. and A.	W.S.D. Macarthur	Ripponhurst
Kruger, E. H.	P.B. 90, Hamilton	Tabor
Kruger, T. W.	Branxholme	"Nullaga", Branxholme
Leditschke, T. C.	Glenisla via Cavendish	Glenisla
Loats, G. R.	R.S.D. 205, Hamilton	"Lyndale", Morgiana
Loats, J. D. (estate of)	P.B. 29, Hamilton	Yulecart
Loats, J. W. and O. G.	P.B. 29, Hamilton	Yulecart
Loats, N. J.	P.B. 29, Hamilton	Yulecart
Loats, W. (estate of)	P.B. 29, Hamilton	Yulecart
Lobb, J. H. and M. A. and Sons	Muntham, Coleraine	"Muntham", Coleraine
McIntyre, R. K.	Wades Road, Narrawong	Narrawong
McLeod, J. R.	"Elm Park", Byaduk	Byaduk
Middleton, A. J. and R.	Box 26, Edenhope	Powers Creek
Millar, Mrs. J. M.	Nandaly	Glenisla
Murray, J. D.	Patyah W.S., Edenhope	Patyah
Neate, F. C.	Victoria Valley	"Rosebank", Victoria Valley
Oswald-Jacobs, J. and V. J.	Benayeo via Apsley	Benayeo
Pye, P. J.	Etrrick Road, Heywood	Heywood, Bessie Belle
Quayle, S. and Son	Heywood	"Oakbank", Heywood
Randell, J. M. and Co.	Harrow	"Tuloona", Harrow
Ridler and Emmerson	P.B. 16, Harrow	Wombelano
Schulz, H. S.	Noskes Road, Milltown	Milltown
Scott, D. S.	"Ardmeen", Casterton	Poolajelo
Scott, R. S. and G.	"Ardmeen", Casterton	Poolajelo
Shaw, J. I.	R.S.D. 519, Coleraine	Wootong Vale
Sharrock, H. J.	Nelson Road, Portland	Portland
Simpson, J. W. (estate of)	Box 30, Apsley	Apsley
Smith, E. E. E. and C. I.	Lower Norton	Lower Norton
Springwood Proprietors	Wannon	"Springwood", Wannon
Talbot, N. M.	Wannon	Wannon
Taylor, G. R.	Box 148, Hamilton	Yatchaw
Thomas, I.	"Glenrowan", Bessie Belle	Millards Road, Homerton
Tod, D. A.	Kadnook via Harrow	Kadnook
Wallis, H. W.	Boundary Road, Condah	Condah
Wallis, J. J.	Boundary Road, Condah	Condah
Wallis, L. G. and G. J.	Boundary Road, Condah	Condah
Wharema Pty. Ltd.	P.B. 8, Hamilton	"Greenbanks", Condah
Wilson, N. and M. F.	Kadnook via Edenhope	"Sleatbank", Morgiana
Wood, H. L. (estate of)	Balmoral	Powers Creek, Edenhope
Young, J. L. C.	Box 141, Hamilton	"Englewood", Balmoral
Zerbst, E. H. Pty. Ltd.	P.B. -176, Horsham	North-Hamilton
Zippel, D. A.	36 Tucker Street, Horsham	Brimpaen Wonwondah

The following is a list of those properties within the Footrot Control Area which have been released from quarantine or restrictions since 1st June, 1977.

Name	Address	Farm Location
Dalton, E. J.	"Cornfield", Condah	Wallacedale
Dunn, W. J. C. (estate of)	Boundary Road, Condah	Condah
Dunstan, F. J. and D. N.	Henty Highway, Condah	Condah
Kunnuk Partnership	Merino	"Kunnuk", Merino
Saunders, H.	35 Clarke Street, Hamilton	Cavendish
Schmidt, W. J.	Port Fairy Road, Hamilton	"Garmula", Byaduk North
Stevenson, M. J.	Mount Richmond	Gorae West
Zippel, D. A.	36 Tucker Street, Horsham	Bungalally and Lower Norton

CONTRACTS ACCEPTED—(Series 1877-78)

AMENDMENTS

Sched. No.	Item No.	Description	Unit of Measurement	New Rate	Contractor	Effective Date
		General Stores		\$		
		<i>Gazette No. 74—1st September, 1977</i>				
1/05		<i>Electrical Goods (Appliances, Cables and Accessories)</i>				
	59	Tape Adhesive Insulating ½" x 25 yards 65-102 Items 65-83 less trade of 32% Items 84-102 less trade of 33%	per coil	0.85 List 15.7.77	Cablemakers (ACT) Pty. Ltd. Olex Cables	6.9.77 29.8.77
1/13		<i>Paint and Painters Sundries</i>				
		<i>Gazette No. 56—1st August, 1977</i>				
	45	Oil weather proofing clear 4 litre tin	per tin	5.30	The National Group of Paint Companies Mobil Oil Australia Ltd.	15.9.77 19.8.77
	46	" " " " 1 " "	"	1.48		
	97	Turps Mineral—in 20 litre drums	per litre	0.1942		
	98	" " " " 200 " " Item 98 Drum deposit plus normal Country Zone differentials	"	0.1192		
1/16		<i>Toilet Requirements</i>				
	4	Facial Tissue 50 packets per carton	per ctn.	13.94	Bowater Scott	3.10.77
	5	Toilet paper 1,000 sheets 60 rolls per ctn. In lots of 240 cartons or more	"	15.55		
		" " " " 100-239 cartons	"	16.35		
		" " " " 50-99 cartons	"	16.75		
		" " " " 10-49 cartons	"	17.15		
	8	Towelling paper 100 metres 16 rolls per ctn. In lots of 240 cartons or more	"	12.52	Bowater Scott	3.10.77
		" " " " 100-239 cartons	"	13.17		
		" " " " 50-99 cartons	"	13.49		
		" " " " 10-49 cartons	"	13.81		
1/33		<i>Nails, Rivets, Screws, etc.</i>				
	21	Gimp Pins		List* 1.8.77	Thomas Warburton Pty. Ltd.	12.9.77
	22	Panel Pins		less 10%		
	26	Copper Rivets and washers		less 10%		
	27	Steel Pan Hd Rivets		less 47%		
	28	Steel Round Hd Rivets		less 13%		
	29	Tinsmens Rivets (Bulk)		less 13%		
	30	Tinsmens Rivets (Tinned)		less 47%		
	38	Copper tacks		less 47%		
		*list Sidney Cooke as at 1.2.77		less 20%		
		*list Sidney Cooke as at 1.8.77				
		2% Settlement Discount 30 days				
1/53		<i>Motor Spirit, Kerosene, Fuel Oils and Lubricants</i>				
	31	Bunker Fuel in bulk	per tonne	87.96	B.P. Australia Ltd.	2.9.77
1/56		<i>Tools (General)</i>				
		<i>Gazette No. 19—4th April, 1977</i>				
	468	Silver Solder Easy F102	per kg	71.98	Matthey Garrett Pty. Ltd.	1.9.77
	469	Silver Solder Matt Braze 34	"	60.77		
		<i>Provisions</i>				
		<i>Gazette No. 43—6th June, 1977</i>				
2/01		<i>Provisions—Melbourne and Metropolitan District</i>				
	13	5 kg boxes Sunflakes	per box	2.34	White Wings Ltd.	6.9.77
	21	Powdered Mouses 5 kg	per bag	6.04		
	23	Pudding Mix Instant Desserts 5 kg bags	"	5.40		
	24	Sponge Mix 25 kg bag	"	10.83		
	26	Self Saucing Sponge Pudding Mix 5 kg Chocolate	"	4.65		
	47	Custard No. Bake Egg 25 lb bags	each	27.44		
	84	Juices Lemon Flavoured Crystal 30 litre	each	4.63		
	86	Juices Orange Flavoured Crystals 30 litre	"	4.63		
	107	Tomato Concentrate/booster 900 ml	per tin	4.37		

AMENDMENTS—continued

Sched. No.	Item No.	Description	Unit of Measurement	New Rate	Contractor	Effective Date			
		Provisions—continued:			\$				
		<i>Milk Fresh and Pure for Mental Hospitals Etc.</i>							
	131	Bulk in metal cans—10-450 litres daily over 450 " "	per litre	0.2864 0.2828	Metropolitan Dairies Pty. Ltd. . .	30.8.77			
	132	Scholle Packs 25 litre— 10-450 litres daily Over 450 litres daily	"	0.3165 0.3129					
	133	Scholle Packs 10 litre— 10-450 litres daily over 450 litres daily	"	0.3165 0.3129					
	134	Bottles—600 ml	"	0.3091					
		<i>Milk Fresh and Pure for Royal Park, Etc.</i>							
	135	Bulk in metal cans—10-450 litres daily over 450 " "	"	0.2864 0.2826					
	136	Scholle Packs 25 litre— 10-450 daily over 450 litres daily	"	0.3165 0.3129					
	137	Scholle Packs 10 litres— 10-450 litres daily over 450 litres daily	"	0.3165 0.3129					
	138	Bottles 600 ml	"	0.3091					
2/09		<i>Provisions—Bendigo District Sub-Schedule No. 2—Milk</i>							
	1	Milk Fresh and Pure Bulk 25 litre bag	per bag	7.67			Sandhurst Dairies Ltd.	1.9.77	
	2	" " " " " 10 litre bag	"	3.21					
	3	" " " " " Carton 1 litre	per ctn.	0.3378					
	4	" " " " " 600 ml	"	0.2115					

W. L. ROBERTSON, Secretary to the Tender Board

CONTRACTS ACCEPTED—(Series 1977-78)

PUBLIC WORKS

307. Melbourne, additional pipework and controls associated with new chiller installation, Police Headquarters, 380 William Street, \$21,459.—A. G. Coombs Constructing.

308. Melbourne, supply of various contract furniture to Public Works Department Storeyard, period 1st June, 1977-30th June, 1978, Rates.—Alsaf Industries Pty. Ltd.

309. Coburg, cleaning of Social Welfare Department, 444 Sydney Road, 1st September, 1977, to 31st August, 1980, \$2,830.12 per annum.—Ansett Cleaning & Shampoo Services.

310. Melbourne, supply of various contract furniture to Public Works Department Storeyard, period 1st June, 1977-30th June, 1978, Rates.—Austenna Pty. Ltd.

311. Melbourne, supply of various contract furniture to Public Works Department Storeyard, period 1st June, 1977-30th June, 1978, Rates.—Bera Furniture Pty. Ltd.

312. Portland, staff improvements, High School, \$43,720.00.—B. M. England Pty. Ltd.

313. Melbourne, supply of various contract furniture to Public Works Department Storeyard, period 1st June, 1977, to 30th June, 1978, Rates.—Brownbuilt Ltd.

314. Ballam Park, erection of art/craft block, Stage 3, Technical School, \$376,264.00.—C. D. Mason Constructions Pty. Ltd.

315. Melbourne, supply of 25 No. 5 Module Primary and 25 No. Post Primary Relocatable Buildings, \$1,645,275.00.—Cemac Constructions & Manufacturing.

316. Bayswater, conversion of Home Economics Room, High School, \$19,419.00.—D. P. & B. Cullen.

317. Maroondah, conversion of Home Economics Room, High School, \$20,460.00.—D. P. & B. Cullen.

318. Lilydale, conversion of Home Economics Room, High School, \$25,303.00.—D. P. & B. Cullen.

319. Laburnum, internal and external painting and repairs, Primary School No. 4863, \$11,862.00.—Drake Painting & Maintenance Services.

320. Melbourne, supply of various contract furniture to Public Works Department Storeyard, period 1st June, 1977, to 30th June, 1978, Rates.—Duff Steel Indus. (Vic.) Pty. Ltd.

321. Melbourne, supply of various contract furniture to Public Works Department Storeyard, period 1st June, 1977, to 30th June, 1978, Rates.—Elite-Built Holdings Pty. Ltd.

322. Melbourne, supply of various contract furniture to Public Works Department Storeyard, period 1st June, 1977, to 30th June, 1978, Rates.—F. Falshaw & Sons Pty. Ltd.

323. Melbourne, supply of various contract furniture to Public Works Department Storeyard, period 1st June, 1977, to 30th June, 1978, Rates.—Fyfe Constructions Pty. Ltd.

324. Melbourne, supply of various contract furniture to Public Works Department Storeyard, period 1st June, 1977, to 30th June, 1978, Rates.—Giacobbe Brothers.

325. Melbourne, supply of 44 No. 5 Module Primary Relocatable Class-room Buildings, \$1,663,112.00.—Jennings Industries Ltd.

326. Melbourne, supply of 10 No. 5 Module Primary Relocatable Class-room Buildings, \$349,640.00.—K. G. Renwick Holdings.

327. Melbourne, supply of various contract furniture to Public Works Department Storeyard, period 1st June, 1977, to 30th June, 1978, Rates.—Laurion Pty. Ltd.

328. Balwyn, external repairs and painting, Yooralla Special School, \$24,925.00.—Mattioli Bros. Pty. Ltd.

329. Melbourne, supply of various contract furniture to Public Works Department Storeyard, period 1st June, 1977, to 30th June, 1978, Rates.—M.C.S. Matting Co. Pty. Ltd.

330. Melbourne, supply of various contract furniture to Public Works Department Storeyard, period 1st June, 1977, to 30th June, 1978, Rates.—Metallic Furniture Pty. Ltd.

331. Melbourne, supply of various contract furniture to Public Works Department Storeyard, period 1st June, 1977, to 30th July, 1978, Rates.—Mirex Engineering Pty. Ltd.

332. Melbourne, supply of various contract furniture to Public Works Department Storeyard, period 1st June, 1977, to 30th July, 1978, Rates.—Nally Ltd.

333. Melbourne, supply of various contract furniture to Public Works Department Storeyard, period 1st June, 1977, to 30th July, 1978, Rates.—Namco Furniture (Vic.).

334. Melbourne, supply of various contract furniture to Public Works Department Storeyard, period 1st June, 1977, to 30th July, 1978, Rates.—Namco Furniture (Vic.).

335. Dandenong, cleaning of Labour and Industry Department, 106 Foster Street, 1st September, 1977, to 31st August, 1980, \$1,045.86 per annum.—Palenti Dutch Cleaning Services Pty. Ltd.

336. Melbourne, supply of various contract furniture to Public Works Department Storeyard, period 1st June, 1977, to 30th June, 1978, Rates.—Peerless Glass Pty. Ltd.

337. Belmont, erection of Stage 2, Technical School, \$1,681,888.00.—Prentice Builders Pty. Ltd.

338. Daylesford, site works, Technical School, \$99,807.00.—Rainbow Constructions Co. Pty. Ltd.

339. Melbourne, supply of various contract furniture to Public Works Department Storeyard, period 1st June, 1977, to 30th June, 1978, Rates.—Raleigh Nursery Pty. Ltd.

340. Melbourne, supply of various contract furniture to Public Works Department Storeyard, period 1st June, 1977, to 30th June, 1978, Rates.—Richman Tubular Industries Pty. Ltd.

341. Melbourne, supply of various contract furniture to Public Works Department Storeyard, period 1st June, 1977, to 30th June, 1978, Rates.—Rokor (Australia) Pty. Ltd.

342. Melbourne, supply of various contract furniture to Public Works Department Storeyard, period 1st June, 1977, to 30th June, 1978, Rates.—Rula Furniture.

343. Melbourne, cleaning of Bingo Board and Public Records Office, 99 Spring Street, period 1st September, 1977, to 31st August, 1980, \$2,424.80 per annum.—Samuel Kay Holdings Pty. Ltd.

344. Donvale, conversion of Home Economics Room, High School, \$21,541.00.—S. G. & R. M. Spargo.

345. Nunawading, conversion of Home Economics Room, High School, \$26,417.00.—S. G. & R. M. Spargo.

346. Glen Waverley, conversion of Home Economics Room, High School, \$22,547.00.—S. G. & R. M. Spargo.

347. Melbourne, supply of various contract furniture to Public Works Department Storeyard, period 1st June, 1977, to 30th June, 1978, Rates.—Stem Tubular Industries Pty. Ltd.

348. Brunswick, external repairs and painting to main administration block, Police Traffic Centre, Dawson Street, \$24,000.00.—Super Painting & Dec. Pty. Ltd.

349. Melbourne, supply of various contract furniture to Public Works Department Storeyard, period 1st June, 1977, to 30th June, 1978, Rates.—Ultra Furniture.

350. Melbourne, supply of 41 No. 5 Primary Relocatable Class-room Buildings, Relocatable Buildings, \$1,428,768.00.—Van Driel (Aus.) Pty. Ltd.

351. Melbourne, supply of various contract furniture to Public Works Department Storeyard, period 1st June, 1977, to 30th June, 1978, Rates.—Weeks & Hansen Pty. Ltd.

352. Melbourne, supply of various contract furniture to Public Works Department Storeyard, period 1st June, 1977, to 30th June, 1978, Rates.—Wormald Safe & Vault Co.

353. Melbourne, supply of various contract furniture to Public Works Department Storeyard, period 1st June, 1977, to 30th June, 1978, Rates.—Wycombe Industries Pty. Ltd.

354. Melbourne, supply of various contract furniture to Public Works Department Storeyard, period 1st June, 1977, to 30th June, 1978, Rates.—Zim Metal Products Pty. Ltd.

D. J. LITTLE, Director-General. 9.9.77

ORDERS IN COUNCIL—(Series 1977-78)

PUBLIC WORKS

His Excellency the Governor of the State of Victoria, by and with the advice of the Executive Council thereof, has by Orders made on the 6th day of September, 1977, approved of the acceptance by the Minister of Public Works of the under-mentioned offers without public tenders being invited, viz.:

Offer of Burroughs Ltd. for purchase of additional B.7700 equipment in connection with E.D.P. facilities for the Public Service, for the sum of One million seven hundred and forty-four thousand six hundred and six dollars (\$1,744,606.00)—(CA.104663II).

Offer of Bruce Southon Pty. Ltd., for heating to "Aquila" and "Capricorn" Wards, Bendigo Psychiatric Centre, for the sum of Twenty-four thousand two hundred and twenty-seven dollars forty-five cents—(\$24,227.45)—(N.58584).

Offer of Hillside Quarries, for supply of 1,200 cubic metres of basalt spalls, for foreshore erosion works at Inverloch, for the sum of Twelve thousand two hundred and forty dollars (\$12,240.00)—(PH.92446II).

Offer of Pronto Mixed Concrete Pty. Ltd., for supply of stabilized sand, Newport Power Station, for the sum of Twelve thousand eight hundred dollars (\$12,800.00)—(S.135392).

Offer of John G. Crowder & Sons Pty. Ltd., for fitting out works to leased premises, 30-44 Young Street, Frankston, Social Welfare Department, for the sum of twenty-five thousand dollars (\$25,000.00)—(P.6649).

TOM FORRISTAL,

Clerk of the Executive Council

At the Executive Council Chamber,
Melbourne, 6th September, 1977

Melbourne and Metropolitan BOARD OF WORKS GENERAL NOTICE

The Melbourne and Metropolitan Board of Works having made provision for carrying off the sewage of each and every property which or any part of which is situate in the Sewerage areas hereinafter described doth hereby declare that on and after the 19th day of September, 1977, each and every property so situate shall be deemed to be a seweraged property within the meaning of the Melbourne and Metropolitan Board of Works Act 1958.

The Sewerage Areas hereinbefore referred to are:—

Sewerage Area No. 3314

City of Knox—Commencing at the junction of Burwood Highway and Ferntree Gully Road; thence westerly and south-westerly along Ferntree Gully Road, northerly along the western boundaries of lots 2 Ferntree Gully Road and 1 Burwood Highway, westerly and northerly along the southern and western boundaries of lot 2 Burwood Highway, south-easterly along Burwood Highway to a point 95 metres south-easterly of Kelvin Drive, north-easterly by a line parallel to Kelvin Drive a distance of 87 metres, south-easterly by a line parallel to Burwood Highway a distance of 49 metres, north-easterly by a line parallel to Kelvin Drive a distance of 98 metres, south-easterly by a line parallel to Burwood Highway a distance of 40 metres, south-westerly by a line parallel to Kelvin Drive a distance of 146 metres, south-easterly along the north-eastern boundaries of lots 2, 1, 15 and 16 Burwood Highway, south-westerly along the south-eastern boundary of the said lot 16, south-easterly along Burwood Highway to the commencing point.

Sewerage Area No. 3316

City of Nunawading—Commencing at the junction of Peck Street and Hawthorn Road; thence westerly along Hawthorn Road, northerly along the western boundary of lot 1 Hawthorn Road, easterly along the northern boundaries of lots 1 to 6 Hawthorn Road, southerly along the eastern boundary of the said lot 6, westerly along Hawthorn Road to the commencing point.

Sewerage Area No. 3317

Shire of Whittlesea—This area includes lots 91 to 100 Virginia Crescent.

Sewerage Area No. 3318

Shire of Diamond Valley—All lots in Senior Court, lots 6 to 12, 14 and 15 Macorna Street.

Sewerage Area No. 3319

City of Broadmeadows—All lots in Hugo Court, lots 239 to 246, 364 to 377, 343, 344, and 363 to 353 Alec Crescent, lots 335 to 342 Hogan Street, lots 387 to 417 and 422 to 442 Somerlayton Crescent, lots 443 to 447 and 453 to 462 Anderson Road.

Sewerage Area No. 3320

City of Sunshine—This area is bounded by Tennant Street, McIntyre Road, Alvina Street and Ford Avenue.

Sewerage Area No. 3323

City of Knox—Lots 30 to 28 Pine Wood Drive, 27 and 77 to 80 Gates Head Drive.

Sewerage Area No. 3324

City of Ringwood—This area includes lots 1 to 5 Mullum Road; lots 8 to 12, 13 to 15, 38 and 39 Hendra Grove and lot 16 Sang Court.

Sewerage Area No. 3325

Shire of Diamond Valley—Commencing at the junction of Sellars Street and Kurrajong Crescent; thence westerly along Kurrajong Crescent, northerly along the western boundaries of lots 1 and 19 to 16 Sellars Street, easterly along the northern boundary of the said lot 16, southerly along Sellars Street to the commencing point.

Sewerage Area No. 3326

City of Sunshine—This area is bounded by Lincoln Street, Duke Street, Wiltshire Street and Cumberland Street.

Sewerage Area No. 3327

City of Keilor—All lots in Herbert Crescent, Craig Street, Pamela Avenue and lots 1 to 10, 3 to 27, 116 to 126, 67 to 65 and 23 to 13 Noga Avenue, lots 38 to 27 and 57 to 43 David Avenue, lots 76 to 61 Lincoln Drive, lots 11 and 12, 41, 42, 78 and 77 Rachele Road, lots 1, 2, 64 to 51, 210, 24 to 26 and 58 to 60 Brees Road.

Sewerage Area No. 3328

Shire of Whittlesea—All lots in Brigette Court and Melanee Court, lots 263 and 262 Buffalo Drive, lots 364 to 370, 259, 237, 371, 372, 387 to 397 and 409 to 411 Franklin Road, lots 232 to 230 Summit Court, lots 227 to 225 Alpine Court, lots 140 and 422 to 418 Edgars Road and lots 412 to 417 Barry Road.

Sewerage Area No. 3329

City of Knox—This area includes all lots in Walker Court.

By order of the Board,

O. T. W. COSGRIFF,

Acting Secretary

625 Little Collins Street, Melbourne, 3001, 13th September, 1977

Town and Country Planning Act 1961**NOTICE OF ORDER UNDER SECTION 32 (5)**

In pursuance of the provisions of section 32 of the *Town and Country Planning Act 1961*, the Governor in Council on the 6th September, 1977, made an Order under section 32 (5) with respect to the use and development of an area of land situated on lot 511, lodged plan 54592, Parish of Yuroke in Pines Way, Craigieburn.

A copy of the Order may be inspected during office hours at the office of the Town and Country Planning Board, 235 Queen Street, Melbourne and at the office of the Council of the Shire of Bulla at Sunbury.

W. H. CRAIG, Secretary

Town and Country Planning Board

Town and Country Planning Act 1961**NOTICE OF ORDER UNDER SECTION 32 (5)**

In pursuance of the provisions of section 32 of the *Town and Country Planning Act 1961*, the Governor in Council on the 6th September, 1977, made an Order under section 32 (5) with respect to the use and development of an area of land situated on Crown Allotment 65, Parish of Whanregarwen.

A copy of the Order may be inspected during office hours at the office of the Town and Country Planning Board, 235 Queen Street, Melbourne and at the office of the Council of the Shire of Alexandra at Alexandra.

W. H. CRAIG, Secretary

Town and Country Planning Board

Town and Country Planning Act 1961**NOTICE OF ORDER UNDER SECTION 32 (5)**

In pursuance of the provisions of section 32 of the *Town and Country Planning Act 1961*, the Governor in Council on the 6th September, 1977, made an Order under section 32 (5) with respect to the use and development of an area of land situated on Crown Allotment 69A, Parish of Whanregarwen.

A copy of the Order may be inspected during office hours at the office of the Town and Country Planning Board, 235 Queen Street, Melbourne and at the office of the Council of the Shire of Alexandra at Alexandra.

W. H. CRAIG, Secretary

Town and Country Planning Board

Town and Country Planning Act 1961**NOTICE OF ORDER UNDER SECTION 32 (5)**

In pursuance of the provisions of section 32 of the *Town and Country Planning Act 1961*, the Governor in Council on the 6th September, 1977, made an Order under section 32 (5) with respect to the use and development of

an area of land in the Parish of Moorooduc bounded by Racecourse Road, Bentons Road, Dunns Road and Tyabb Road, but excluding lot 1, lodged plan 111582.

A copy of the Order may be inspected during office hours at the office of the Town and Country Planning Board, 235 Queen Street, Melbourne and at the office of the Council of the Shire of Mornington at Mornington.

W. H. CRAIG, Secretary
Town and Country Planning Board

Town and Country Planning Act 1961**NOTICE OF ORDER UNDER SECTION 32 (5)**

In pursuance of the provisions of section 32 of the *Town and Country Planning Act 1961*, the Governor in Council on the 6th September, 1977, made an Order under section 32 (5) with respect to the use and development of an area of land situated on part of Crown Allotment 1, Section 7, Parish of Merrimu and more particularly described in Certificate of Title Volume 5929, Folio 634.

A copy of the Order may be inspected during office hours at the office of the Town and Country Planning Board, 235 Queen Street, Melbourne and at the office of the Council of the Shire of Bacchus Marsh at Bacchus Marsh.

W. H. CRAIG, Secretary
Town and Country Planning Board

Town and Country Planning Act 1961**CITY OF BENALLA PLANNING SCHEME****AMENDMENT No. 14****Notice of Approval**

In pursuance of the powers conferred by the *Town and Country Planning Act 1961*, the Governor in Council on the 6th September, 1977, approved a planning scheme entitled the City of Benalla Planning Scheme, Amendment No. 14, in respect of part of the municipal district of the City of Benalla and such planning scheme comes into operation on the date this Notice of Approval is published in the *Government Gazette*.

A copy of the planning scheme as approved may be inspected, free of charge, during office hours at the office of the Town and Country Planning Board, 235 Queen Street, Melbourne, at the office of the Council of the City of Benalla at Benalla and when available, at the Office of Titles, Melbourne, and at the Central Plan Office of the Department of Crown Lands and Survey, Melbourne.

W. H. CRAIG, Secretary
Town and Country Planning Board

Town and Country Planning Act 1961**CITY OF KNOX PLANNING SCHEME 1965****AMENDMENT No. 125A—1977****Notice of Amendment**

In pursuance of the powers conferred by sub-section 6 of section 32 of the *Town and Country Planning Act 1961*, the Governor in Council, on the 6th September, 1977, amended the City of Knox Planning Scheme to provide for road closures on land on the corner of Stud Road and Seebeck Road, Rowville.

A copy of the amendment may be inspected during office hours at the office of the Town and Country Planning Board, 235 Queen Street, Melbourne, at the Office of the Council of the City of Knox and when available at the Office of Titles, Melbourne, and at the Central Plan Office of the Department of Crown Lands and Survey, Melbourne.

W. H. CRAIG, Secretary
Town and Country Planning Board

Town and Country Planning Act 1961**SHIRE OF ALEXANDRA PLANNING SCHEME****REVOCATION No. 1****Notice of Revocation**

In pursuance of the provisions of section 32 of the *Town and Country Planning Act 1961* the Governor in Council on the 6th September, 1977, made an Order revoking the Shire of Alexandra Planning Scheme in so far as it applies to Crown Allotment 69A, Parish of Whanregarwen.

A copy of the Order may be inspected during office hours at the office of the Town and Country Planning Board, 235 Queen Street, Melbourne, and at the office of the Shire of Alexandra at Alexandra.

W. H. CRAIG, Secretary
Town and Country Planning Board

Town and Country Planning Act 1961
SHIRE OF ALEXANDRA PLANNING SCHEME
 REVOCATION No. 2
Notice of Revocation

In pursuance of the provisions of section 32 of the *Town and Country Planning Act 1961* the Governor in Council on the 6th September, 1977, made an Order revoking the Shire of Alexandra Planning Scheme in so far as it applies to Crown Allotment 65, Parish of Whanregarwen.

A copy of the Order may be inspected during office hours at the office of the Town and Country Planning Board, 235 Queen Street, Melbourne, and at the office of the Council of the Shire of Alexandra at Alexandra.

W. H. CRAIG, Secretary,
 Town and Country Planning Board

Town and Country Planning Act 1961
SHIRE OF BACCHUS MARSH PLANNING SCHEME
 REVOCATION No. 5
Notice of Revocation

In pursuance of the provisions of section 32 of the *Town and Country Planning Act 1961* the Governor in Council on the 6th September, 1977, made an Order revoking the Shire of Bacchus Marsh Planning Scheme in so far as it applies to approximately 63 hectares of land being part of Crown Allotment 1, section 7, Parish of Merrimu.

A copy of the Order may be inspected during office hours at the office of the Town and Country Planning Board, 235 Queen Street, Melbourne, and at the office of the Council of the Shire of Bacchus Marsh at Bacchus Marsh.

W. H. CRAIG, Secretary,
 Town and Country Planning Board

Town and Country Planning Act 1961
SHIRE OF BULLA PLANNING SCHEME 1959
 REVOCATION No. 7
Notice of Revocation

In pursuance of the provisions of section 32 of the *Town and Country Planning Act 1961* the Governor in Council on the 6th September, 1977, made an Order revoking the Shire of Bulla Planning Scheme in so far as it applies to lot 511, lodged plan 54592, Parish of Yuroke in Pines Way, Craigieburn.

A copy of the Order may be inspected during office hours at the office of the Town and Country Planning Board, 235 Queen Street, Melbourne, and at the office of the Council of the Shire of Bulla at Sunbury.

W. H. CRAIG, Secretary,
 Town and Country Planning Board

Town and Country Planning Act 1961
SHIRE OF FLINDERS PLANNING SCHEME 1962
 AMENDMENT No. 94, 1977
 INTERIM DEVELOPMENT ORDER
Notice of Approval

In pursuance of the powers conferred by the *Town and Country Planning Act 1961*, the Governor in Council on the 6th day of September, 1977, approved an Interim Development Order made by the Flinders Shire Council for part of the municipal district of the Shire of Flinders, being land generally bounded by Hotham Road, Portsea Ocean Park Reserve, the Quarantine Station and Nepean Highway at Portsea.

The Interim Development Order provides that the use, subdivision or development of any land within the area described or the erection, construction or carrying out of any buildings, roads or other works thereon is prohibited except that the Responsible Authority may permit such uses, subdivision, development, erection, constructions or other works as it thinks proper, and further except for the exclusions contained within the Order.

A copy of the Interim Development Order and a map showing the area affected may be inspected, free of charge, at the office of the Shire of Flinders, Municipal Offices, Boneo Road, Rosebud, and at the office of the Town and Country Planning Board, 235 Queen Street, Melbourne.

W. H. CRAIG, Secretary,
 Town and Country Planning Board

Town and Country Planning Act 1961
SHIRE OF MORNINGTON PLANNING SCHEME 1959
 REVOCATION No. 3
Notice of Revocation

In pursuance of the provisions of section 32 of the *Town and Country Planning Act 1961* the Governor in Council on the 6th September, 1977, made an Order revoking the Shire of Mornington Planning Scheme in so far as it applies to land in the Parish of Moorooduc bounded by Racecourse Road, Bentons Road, Dunns Road and Tyabb Road, but excluding Lot 1, lodged Plan 111582.

A copy of the Order may be inspected during office hours at the office of the Town and Country Planning Board, 235 Queen Street, Melbourne, and at the office of the Council of the Shire of Mornington at Mornington.

W. H. CRAIG, Secretary,
 Town and Country Planning Board

Town and Country Planning Act 1961
OVENS-UPPER MURRAY PLANNING SCHEME
 INTERIM DEVELOPMENT ORDER 1975
 REVOCATION No. 5
Notice of Revocation

In pursuance of the powers conferred by section 26 of the *Town and Country Planning Act 1961*, the Governor in Council on the 6th September, 1977 revoked the Ovens-Upper Murray Planning Scheme Interim Development Order 1975 in respect of that area of the Shire of Yackandandah to be covered by the Shire of Yackandandah Rural Area Interim Development Order 1976 and more particularly described on the maps annexed to the Order of Revocation.

A copy of the revocation may be inspected during office hours at the office of the Town and Country Planning Board, 235 Queen Street, Melbourne and at the office of the Council of the Shire of Yackandandah at Yackandandah.

W. H. CRAIG, Secretary,
 Town and Country Planning Board

Town and Country Planning Act 1961
SHIRE OF ROCHESTER (ROCHESTER TOWNSHIP)
 PLANNING SCHEME
 AMENDMENT No. 7
Notice of Amendment

In pursuance of the powers conferred by sub-section 6 of section 32 of the *Town and Country Planning Act 1961*, the Governor in Council, on the 6th September, 1977, amended the Shire of Rochester (Rochester Township) Planning Scheme in respect of Section 19, Township of Rochester, to allow a reduced setback of 6 metres from the eastern boundary of that land, in lieu of 7.5 metres.

A copy of the amendment may be inspected during office hours at the office of the Town and Country Planning Board, 235 Queen Street, Melbourne, at the office of the Council of the Shire of Rochester at Rochester, and when available at the Office of Titles, Melbourne, and at the Central Plan Office of the Department of Crown Lands and Survey, Melbourne.

W. H. CRAIG, Secretary,
 Town and Country Planning Board

Town and Country Planning Act 1961
SHIRE OF WANNON PLANNING SCHEME
 INTERIM DEVELOPMENT ORDER
Notice of Approval

In pursuance of the powers conferred by the *Town and Country Planning Act 1961*, the Governor in Council on the 6th day of September, 1977, approved an Interim Development Order made by the Wannon Shire Council for the whole of the municipal district of the Shire of Wannon.

The Interim Development Order provides that the use, subdivision or development of any land within the area described or the erection, construction or carrying out of any buildings, roads or other works thereon is prohibited except in accordance with the provisions of the Order.

A copy of the Interim Development Order and a map showing the area affected may be inspected, free of charge, at the office of the Council of the Shire of Wannon, 71 Whyte Street, Coleraine, and at the office of the Town and Country Planning Board, 235 Queen Street, Melbourne.

G. J. WALLIS, Shire Secretary

Town and Country Planning Act 1961
SHIRE OF YACKANDANDAH PLANNING SCHEME
RURAL AREA INTERIM DEVELOPMENT ORDER 1976
Notice of Approval

In pursuance of the powers conferred by the *Town and Country Planning Act 1961*, the Governor in Council on the 6th day of September, 1977, approved an Interim Development Order made by the Yackandandah Shire of Yackandandah for part of the municipal district of the Shire of Yackandandah.

The Interim Development Order provides that the use, subdivision or development of any land within the area described or the erection, construction or carrying out of any building, roads or other works thereon is prohibited except in accordance with the provisions of the Order.

A copy of the Interim Development Order and a map showing the area affected may be inspected, free of charge, at the office of the Council of the Shire of Yackandandah at Yackandandah and at the office of the Town and Country Planning Board, 235 Queen Street, Melbourne.

W. H. CRAIG, Secretary,
Town and Country Planning Board

PUBLIC TRUSTEE ACT 1958 (No. 6350), SECTION 17

I hereby give notice that on the 24th August, 1977 the Public Trustee filed elections to administer the following deceased persons' estates in accordance with section 17 of the *Public Trustee Act 1958*.

BEATTIE, DUDLEY JAMES, formerly of 203 Lennox Street, Richmond but late of Flat 3, 87 Gardner Street, Richmond, retired proof reader, died 3rd May, 1977.

BILL, RUTH, late of 59 Clarence Street, East Brunswick, spinster, died 16th June, 1977.

DOBSON, IVY MAY, formerly of 27 Gardiner Parade, Glen Iris, but late of 62 Rose Avenue, Glen Waverley, retired process worker, died 1st July, 1977.

MCINNES, AGNES ELLEN, late of Ballarat, widow, died 23rd March, 1977.

MYERS, ALBERTA MABEL, formerly of 14 Bower Street, South Northcote, but late of Flat 5, 22 Thomson Street, Northcote, widow, died 1st July, 1977.

PENMAN, AIDEEN CATHERINE, late of Flat 2, 94 Ormond Street, Flemington, spinster, died 26th June, 1977.

ROY, ALLAN, late of Mont Park, pensioner, died 17th March, 1977.

THOMPSON, ETHEL, formerly of 158 Outlook Drive, North Dandenong but late of 10 Geelong Road, Footscray, widow, died 24th June, 1977.

WILSON, ANNIE, late of Caritas Christie Hospice, Studley Park Road, Kew, widow, died 21st May, 1977.

I hereby give notice that on the 31st August, 1977 the Public Trustee filed elections to administer the following deceased persons' estates in accordance with Section 17 of the *Public Trustee Act 1958*.

CHAMBERS, ALWYN LAWRENCE, formerly of 10 Faringdon Street, Pascoe Vale, but late of Kew, retired clerk, died 26th April, 1977.

DUTTON, JOHN ALFRED, late of 11 Bindy Street, South Blackburn, carpenter, died 27th June, 1977.

HULTMARK, KARL LENNART, also known as Hultmark Karl Lenhart, late of Inala Village, Flat 9, 220 Middleborough Road, South Blackburn, retired school teacher, died 25th June, 1977.

JACKSON, WILLIAM HENRY, late of Gill Memorial, 217 A'Beckett Street, Melbourne, retired gardener, died 20th June, 1977.

KAYE, MABEL VICTORIA, late of "Devon Lodge" High Street, Woodend, spinster, died 19th February, 1977.

KELLETT, ELAINE MARY, (in the will called Elaine Kellett), formerly of 7 Rotherwood Road, Ivanhoe but late of Chantee Nursing Home, 25 Thoresby Grove, Ivanhoe, widow, died 8th May, 1977.

MCFADDEN, GEORGE JOHN, formerly of 601 New South Head Road, Rose Bay, N.S.W., but late of 214 Arden Street, North Melbourne, retired P.M.G. mechanic, died 14th December, 1976.

PARKER, VICTOR ALFRED, late of 41 Young Street, Albert Park, pensioner, died 22nd June, 1977.

SLOAN, WILLIAM CAMPBELL, late of 450 (formerly 69) Park Street, North Carlton, retired engineer, died 29th May, 1977.

SMITH, FLORENCE, late of Chantee Nursing Home, 25 Thoresby Grove, Ivanhoe, spinster, died 8th July, 1977.

No. 76—8910/77—2

I hereby give notice that on the 2nd September, 1977, the Public Trustee filed elections to administer the following deceased persons' estates in accordance with Section 17 of the *Public Trustee Act 1958*.

HOWARD, WILLIAM GEORGE, late of Warrnambool, retired labourer, died 25th May, 1977.

JARDINE, GENIEVE LILIAN, formerly of 1 Roberta Grove, Frankston but late of Unit 6, 17 York Street, Bonbeach, married woman, died 16th March, 1977.

LLOYD, ALICE, formerly of 21 Walker Street, Newport, but late of Mont Park, widow, died 5th April, 1977.

MATTHEWS, JAMES FREDERICK, late of 10 Kett Street, Lower Plenty, pensioner, died 26th April, 1976.

MORTON, ELFREDA ELIZABETH, also known as Freda Morton, late of Flat 183, 127 Gordon Street, Footscray, spinster, died 13th May, 1977.

MOTTERAM, FRANCES MAY, late of Flat 45, 25 King Street, Prahran, widow, died 10th July, 1977.

MURPHY, AUGUSTINE, late of 263A Springfield Road, Nunawading, retired, died 25th May, 1977.

SUTTON, PATRICIA ELEANOR, late of Mount Royal Special Hospital for the Aged, Parkville, widow, died 17th May, 1969.

TRELOAR, ANNIE ELVA, late of 109 Station Street, Burwood, married woman, died 17th March, 1977.

WILSON, ELIZABETH MARY, late of Gippsland Geriatric Centre, McKean Street, Bairnsdale, pensioner, died 15th June, 1977.

WYATT, MARY, late of Kingston Centre, Warrigal Road, Cheltenham, spinster, died 29th September, 1974.

168 Exhibition Street, Melbourne, 3000, 6th September, 1977.

N. P. BRODY,
Public Trustee

Creditors, next of kin, and others having claims against the estate of any of the under-mentioned deceased persons are required to send particulars of their claims to the Public Trustee, 168 Exhibition Street, Melbourne, Vic. 3000, the personal representative, on or before the 23rd November, 1977 after which date the Public Trustee may convey or distribute the assets having regard only to the claims of which the Public Trustee then has notice:—

ASHMAN, KEVIN ALLAN, also known as Kevin Allen Ashman, late of 9 Edgerton Street, Hawthorn, pay clerk, died 10th January, 1977.

BEATTIE, DUDLEY JAMES, formerly of 203 Lennox Street, Richmond but late of Flat 3, 87 Gardner Street, Richmond, retired proof reader, died 3rd May, 1977.

BILL, RUTH, late of 59 Clarence Street, East Brunswick, spinster, died 16th June, 1977.

BOATWRIGHT, ROBERT BRUCE VERNON, also known as Bruce Vernon Boatwright, formerly of 53 Gibbon Street, Burnley, but late of Prince Alfred Hospital, 619 Church Street, Richmond, S.E.C. linesman, died 21st May, 1977.

BURGESS, ANNIE MARY, late of 7 Eastern Road, Strathdale, Bendigo, married woman, died 31st May, 1977.

CHAMBERS, ALWYN LAWRENCE, formerly of 10 Faringdon Street, Pascoe Vale, but late of Kew, retired clerk, died 26th April, 1977.

CLAPHAM, VERNON JAMES, formerly of 117 New Street, Brighton, but late of 74 Mitchell Drive, St. Laurence Park, Lara, Victoria, retired pattern maker, died 11th May, 1977.

CLARK, LEO DOUGLAS, late of 2 Prendergast Street, Pascoe Vale South, retired accountant, died 2nd July, 1977.

CLARRICOTES, WILLIAM THOMAS, late of 2 Tells Avenue, Mentone, retired clerk, died 21st January, 1976.

DOBSON, IVY MAY, formerly of 27 Gardiner Parade, Glen Iris, but late of 62 Rose Avenue, Glen Waverley, retired process worker, died 1st July, 1977.

DORAN, ROBERT THOMAS, formerly of Dunolly Road, Betley, but late of Ballarat, retired company director, died 29th November, 1976.

DURJACK, ELMER JOHN, late of Flat 17, 19 Robe Street, St. Kilda, mail officer, died 17th May, 1977.

DUTTON, JOHN ALFRED, late of 11 Bindy Street, South Blackburn, carpenter, died 27th June, 1977.

FARQUHARSON, JEAN ANNE, formerly of 33 Jean Street, Cheltenham but late of flat 17/20 Lisson Grove, Hawthorn, widow, died 30th May, 1977.

HOBBS, THOMAS FRANCIS, late of Devonport, New Zealand, retired chief petty officer, died 31st January, 1977.

HOUGH, RONALD CHARLES, late of 282 Warrigal Road, South Oakleigh, retired clerk, died 28th May, 1977.

HOWARD, WILLIAM GEORGE, late of Warrnambool, retired labourer, died 25th May, 1977.

HULTMARK, KARL LENNART, also known as Hultmark Karl Lenhart, late of Inala Village, Flat 9, 220 Middleborough Road, South Blackburn, retired school teacher, died 25th June, 1977.

JACKSON, WILLIAM HENRY, late of Gill Memorial, 217 A'Beckett Street, Melbourne, retired gardener, died 20th June, 1977.

JARDINE, GENIEVE LILIAN, formerly of 1 Roberta Grove, Frankston but late of Unit 6, 17 York Street, Bonbeach, married woman, died 16th March, 1977.

KAYE, MABEL VICTORIA, late of "Devon Lodge" High Street, Woodend, spinster, died 19th February, 1977.

KELLETT, ELAINE MARY, (in the will called Elaine Kellett), formerly of 7 Rotherwood Road, Ivanhoe but late of Chantee Nursing Home, 25 Thoresby Grove, Ivanhoe, widow, died 8th May, 1977.

KHAN, NAZAM DEEN, late of 347 Station Street, North Carlton, gentleman, died 5th March, 1941.

KING, WINIFRED MABEL, formerly of 35 Donald Street, Prahran and Unit 13, 74 Denbigh Road, Armadale, but late of "Wynnstay Private Hospital", 21 Wynnstay Road, Prahran, widow, died 13th May, 1977.

LLOYD, ALICE, formerly of 21 Walker Street, Newport, but late of Mont Park, widow, died 5th April, 1977.

LUCE, ALMA MAY, late of 9 Kalang Road, Camberwell, spinster, died 30th June, 1977.

LUNNEY, JOHN, late of Flat 6, 48 Sargood Street, Altona, aircraft inspector, died 12th June, 1977.

McFADDEN, GEORGE JOHN, formerly of 601 New South Head Road, Rose Bay, N.S.W., but late of 214 Arden Street, North Melbourne, retired P.M.G. mechanic, died 14th December, 1976.

MCINNES, AGNES ELLEN, late of Ballarat, widow, died 23rd March, 1977.

McSKIMMING, MYRTLE JESSIE, late of Devonport, New Zealand, widow, died 10th January, 1977.

MATTHEWS, JAMES FREDERICK, late of 10 Kett Street, Lower Plenty, pensioner, died 26th April, 1976.

MORRIS, REGINALD FRANK, late of 184 Patterson Road, Moorabbin, retired clerk, died 27th June, 1977.

MORTON, ELFREDA ELIZABETH, also known as Freda Morton, late of Flat 183, 127 Gordon Street, Footscray, spinster, died 13th May, 1977.

MOTTERAM, FRANCES MAY, late of Flat 45, 25 King Street, Prahran, widow, died 10th July, 1977.

MURPHY, AUGUSTINE, late of 263A Springfield Road, Nunawading, retired, died 25th May, 1977.

MYERS, ALBERTA MABEL, formerly of 14 Bower Street, South Northcote, but late of Flat 5, 22 Thomson Street, Northcote, widow, died 1st July, 1977.

PARKER, VICTOR ALFRED, late of 41 Young Street, Albert Park, pensioner, died 22nd June, 1977.

PENMAN, AIDEE CATHERINE, late of Flat 2, 94 Ormond Street, Flemington, spinster, died 26th June, 1977.

PHILLIPS, JOHN FREDERICK, late of 1 Somerville Street, Coburg, retired P.M.G. clerk, died 30th June, 1977.

RISSMANN, ARTHUR ERNEST, late of Dunedin, New Zealand, retired railway officer, died 19th January, 1977.

ROY, ALLAN, late of Mont Park, pensioner, died 17th March, 1977.

SLOAN, WILLIAM CAMPBELL, late of 450 (formerly 69) Park Street, North Carlton, retired engineer, died 29th May, 1977.

SMITH, FLORENCE, late of Chantee Nursing Home, 25 Thoresby Grove, Ivanhoe, spinster, died 8th July, 1977.

SUTTON, PATRICIA ELEANOR, late of Mount Royal Special Hospital for the Aged, Parkville, widow, died 17th May, 1969.

THOMPSON, ETHEL, formerly of 158 Outlook Drive, North Dandenong but late of 10 Geelong Road, Footscray, widow, died 24th June, 1977.

TRELOAR, ANNIE ELVA, late of 109. Station Street, Burwood, married woman, died 17th March, 1977.

TRENAMAN, HORACE VICTOR, formerly of 19 Gardiner Road, Hawthorn, but late of 33 Chesterfield Avenue, Malvern, retired bank officer, died 8th June, 1977.

WILSON, ANNIE, late of Caritas Christie Hospice, Studley Park Road, Kew, widow, died 21st May, 1977.

WILSON, ELIZABETH MARY, late of Gippsland Geriatric Centre, McKean Street, Bairnsdale, pensioner, died 15th June, 1977.

WYATT, MARY, late of Kingston Centre, Warrigal Road, Cheltenham, spinster, died 29th September, 1974.

Melbourne, 7th September, 1977

N. P. BRODY,
Public Trustee

APPOINTMENTS AND RESIGNATIONS

APPOINTMENTS

His Excellency the Governor of the State of Victoria, by and with the advice of the Executive Council thereof, has, by Orders made on the 6th day of September, 1977, been pleased to make the under-mentioned appointments, viz.:

DEPARTMENT OF CROWN LANDS AND SURVEY

Bailiffs of Crown Lands

PETER LINDSAY POTTS and

DAVID WILLIAM RITCHIE,

Inspectors of Lands,

to be bailiffs of Crown lands, without additional salary, in respect of all Crown lands in the State of Victoria, and with authority to discharge and exercise all the duties and powers of bailiffs, pursuant to the provisions of section 30 of the *Land Act 1958*.

DEPARTMENT OF HEALTH

Member of Committee of Management of Hospital

THOMAS RICHARD FLOOD, C.B.E.,

to be Government Appointee on the Committee of Management of the Bendigo Home and Hospital for the Aged, for a further period of three years commencing on the 1st October, 1977, pursuant to the provisions of section 48 (1) (b) of the *Hospitals and Charities Act 1958*.

LAW DEPARTMENT

Justices of the Peace

LESTER GEORGE BAILEY, 1 Phelan Street, Preston,

GEORGE HENRY BENNETT, "Nariel", Nhill,

JOYCE BRYCE, 7 Daisy Street, Violet Town,

PAULINE ANN HOLLAND, 37 Bull Street, Castlemaine,

MARY FRANCES JONES, 124 Ross Street, Port Melbourne,

MALCOLM MAURICE McEGAN, 6 Hinton Close, Gladstone

Park,

ANDREAS VASSILOU MYLONAS, 200. High Street, North-

cote,

CATHERINE ELIZABETH PRICE, 2 Colorado Street, Pascoe

Vale,

VALMA MARION SMITH, 133 Hogan Street, Tatura, and

GWYNETH LLOYD TERRY, 16 Lewellin Grove, Rosanna, to be Justices of the Peace for the State of Victoria.

Commissioners for Taking Declarations, &c.

DAVID YELVERTON CLIFTON, 530 Glenferrie Road, Hawthorn,

DONALD GEORGE DINNEEN, 159 Main Street, Croydon,

BRUCE ALLAN FILLEUL, 277 William Street, Melbourne,

STAN GUAGAS, 3 Chester Street, Oakleigh,

JOHN DAVID EDWARD HARBURY, 620 Bourke Street, Mel-

bourne,

MAURICE BERNARD HIGGINS, 1 Hamilton Place, Mount

Waverley,

PETER GUNNAR LERSTANG, 75 Chamberlain Road, New-

borough,

NEIL AMBLER McQUALTER, 47 Riverview Road, Benalla,

EVAN JOHN MADDOX, 10 Mulga Street, Altona,

KELVIN BRYAN MATTHEWS, 535 Bourke Street, Mel-

bourne,

COLIN JOHN MURPHY, 2 Treasury Place, Melbourne,

PAUL JAMES NUNN, Shop 40, Eastland Shopping Centre,

171 Maroondah Highway, Ringwood,

MALCOLM CHESTER OWEN, 20 Stubbs Street, Kensing-

ton,

PETER PANOS, 136 Sydney Road, Brunswick,

JAMES LAURIE PATERSON, 10 Moss Court, Glenroy,

IAN WILLIAM PYM, 5 Conan Street, Wendouree,

THOMAS JAMES SCORDO, 47 William Street, Keilor Park,

TIMOTHY RICHARD SIMPSON, 22 Langhorne Street, Dan-

denong,

TREVOR GEORGE WILD, 60-68 Moorabool Street, Geelong,

and

JOSEPHINE SHEILA WILLICOMBE, Level 2, 1239 Nepean

Highway, Cheltenham,

to be Commissioners for Taking Declarations and Affidavits under the *Evidence Act 1958*.

Assistant Collector of Maintenance

GRAEME ADRIAN SHARKEY, Clerk of Courts, Class "CC-2", Second Division, Law Department, to be an Assistant Collector of Maintenance, pursuant to section 69 (1) of the *Maintenance Act 1965*.

Assistant Registrar of County Court

DAVID RICHARD SMITH, Clerk of Courts, Class "CC-2",
Second Division, Law Department,
to be Assistant Registrar at Nhill for the County Court at
Horsham, vice D. J. Lindsay, transferred.

SOCIAL WELFARE DEPARTMENT

Honorary Probation Officers

ALAN DOUGLAS BAKER, 89 Rennie Street, Thornbury,
MARGARET McCALLUM BRADY, 32 Brighton Street, Glen
Waverley,
HILDA LILIAN CLYNE, 48 The Avenue, Ocean Grove,
PATRICIA ANNE COLLINSON, 63 Wellington Street,
Flemington,
HEIDI COLEMAN, Flat 10, 12 Normanby Street, Windsor,
RICHARD CHARLES CORNWILL, 113 Knight Street, Shep-
parton,
SARAH ISABEL COWARD, P.O. Box 166 Mooroopna
(Postal), corner Midland Highway and Craven
Road, Ardmona,
RAINER ELLINGHAUS, 45 Drummond Street, Carlton,
EDWARD JOHN GASON, The Vicarage, Inverleigh,
COLIN ANTHONY GLASSOCK, R.S.D. Clifton Creek Road,
Wy Yung,
NANCY MARY MCFARLANE, 107 Noble Street, Newtown,
Geelong,
PETER JOHN MATHIESON, 10 Clive Road, East Hawthorn,
IAN LEO RICE, 34 Windsor Avenue, McKinnon,
SAID HABIB SADEK, Flat 2, 99 Barkly Street, St. Kilda,
HELEN JOY SANDFORD, Flat 2, Lot 20, Anzac Avenue,
Ferry Creek,
ERIC ALBERT THOMAS SAUNDERS, 280 St. Georges Road,
Thornbury,
ANTHONY SKOROPLAS, Flat 8, 2 Albion Street, East
Brunswick, and
JACK HENRY WILLIS, 51 Gillies Street, Fairfield,
to be Honorary Probation Officers for all Adult and Chil-
dren's Courts in Victoria, pursuant to the provisions of
section 507 (2) of the *Crimes Act 1958* and section 9 of
the *Children's Court Act 1973*.

TOM FORRISTAL,

Clerk of the Executive Council

At the Executive Council Chamber,
Melbourne, 6th September, 1977

*Forests Act 1958*APPOINTMENT OF COMMITTEE OF MANAGEMENT OF
MYERS CREEK SCENIC RESERVE

Whereas by section 50 of the *Forests Act 1958* (No.
6254), it is provided that the Minister of Forests may, on
the recommendation of the Forests Commission, appoint
any number of persons, not less than three, to be a
Committee of Management of any land forming part of
any reserved forest, such land being set aside as a
Scenic Reserve, and may remove any of those persons:
Now therefore I, Frederick James Granter, Her Majesty's
Minister of Forests for the State of Victoria, on the recom-
mendation of the Forests Commission, do hereby appoint—

DAVID HERBERT CLARK,
JOHN GRIER McYEA Junior,
WILLIAM MACAULEY,
STUART McDONALD, and
RODERICK ALAN INCOLL,

as members of the Committee of Management for the
period until the 30th June, 1980, of the land forming part
of the reserved forest in the Parish of Tarrawarra North,
County of Evelyn, described in the accompanying Schedule,
and known as "Myers Creek Scenic Reserve".

SCHEDULE ABOVE REFERRED TO

Parish of Tarrawarra North, County of Evelyn, 83.37
hectares, more or less, being the area shown by pink colour
on plan marked D over 15.5.68, on file of correspondence
No. 74/2173 of the Forests Department.

Dated at Melbourne, the 6th day of September, 1977

F. J. GRANTER,
Minister of Forests

*Forests Act 1958*APPOINTMENT OF COMMITTEE OF MANAGEMENT OF
LAL LAL BLAST FURNACE RESERVE

Whereas by section 50 of the *Forests Act 1958* (No.
6254), it is provided that the Minister of Forests may, on
the recommendation of the Forests Commission, appoint
any number of persons, not less than three, to be a
Committee of Management of any land forming part of
any reserved forest, such land being set aside as a

Recreational and Historical Reserve, and may remove any
of those persons: Now therefore, I, Frederick James
Granter, Her Majesty's Minister of Forests for the State
of Victoria, on the recommendation of the Forests Com-
mission, do hereby appoint—

JEFFREY PETER BRISBANE,
as a member of the Committee of Management until the
1st day of August, 1978, of the land described in the ac-
companying Schedule and known as the "Lal Lal Blast
Furnace Reserve".

SCHEDULE ABOVE REFERRED TO

Parish of Lal Lal, County of Grant, 30.35 hectares more
or less being the area shown coloured yellow on plan
A68/1564 in file of correspondence No. 72/463 of the
Forests Department.

Dated at Melbourne, the 6th day of September, 1977

F. J. GRANTER,
Minister of Forests

*Forests Act 1958*APPOINTMENT OF COMMITTEE OF MANAGEMENT OF
TERRICKS ROCK PICNIC AREA

Whereas by section 50 of the *Forests Act 1958* (No.
6254), it is provided that the Minister of Forests may, on
the recommendation of the Forests Commission, appoint
any number of persons, not less than three, to be a
Committee of Management of any land forming part of
any reserved forest, such land being set aside as a
Picnic Area and may remove any of those persons: Now
therefore, I, Frederick James Granter, Her Majesty's
Minister of Forests, for the State of Victoria, on the recom-
mendation of the Forests Commission, do hereby appoint—

KEITH WILLIAM PHELAN,
as a member of the Committee of Management until the
twenty-second day of April, 1978, of the land forming part
of the reserved forest in the Parish of Terrick Terrick
West, County of Gunbower, described in the accompanying
Schedule, and known as the "Terricks Rock Picnic Area".

SCHEDULE ABOVE REFERRED TO

Parish of Terrick Terrick West, County of Gunbower,
comprising 20.23 hectares, more or less, being the area
shown by red colour on plan marked "A" over 20.11.68
in file of correspondence No. 74/1957 of the Forests De-
partment.

Dated at Melbourne, the 6th day of September, 1977

F. J. GRANTER,
Minister of Forests

*Forests Act 1958*APPOINTMENT OF COMMITTEE OF MANAGEMENT OF
MELVILLE CAVES RESERVE

Whereas by section 50 of the *Forests Act 1958* (No.
6254), it is provided that the Minister of Forests may, on
the recommendation of the Forests Commission, appoint
any number of persons, not less than three, to be a
Committee of Management of any land forming part of
any reserved forest, such land being set aside as a
Scenic Reserve, and may remove any of those persons:
Now therefore, I, Frederick James Granter, Her Majesty's
Minister of Forests for the State of Victoria, on the recom-
mendation of the Forests Commission, do hereby appoint—

DONALD PECKHAM,
MERYN JOHN MASON,
GRAHAM JOHN CATTO,
WILLIAM DONALD MCLEOD,
JOHN KEMSHALL DONOVAN, and
CHARLES ROSS CATTO,

as members of the Committee of Management until the
11th day of May, 1980, of the land forming part of the
reserved forest in the Parish of Kangdaraar, County of
Gladstone, described in the accompanying Schedule, and
known as the "Melville Caves Reserve".

SCHEDULE ABOVE REFERRED TO

Parish of Kangdaraar, County of Gladstone, comprising
48.56 hectares, more or less, being the area shown red on
plan marked A49.1080 over 1.1.50 in file of correspondence
No. 74/143 of the Forests Department.

Dated at Melbourne, the 6th day of September, 1977

F. J. GRANTER,
Minister of Forests

Transport Regulation Act
TRANSPORT REGULATION BOARD
 NOTICE No. 116

Appointment of Inspectors

Take notice that, pursuant to the powers conferred on the Board by the provisions of the Transport Consolidated Regulations 1977, the Board hereby notifies in accordance with Regulation 5 of Part I. of the said Regulations, the appointment as Inspectors of—

Lawrence Rene Travers
 David Henry Sugden

while such persons are in uniform within the corporate limits of the City of Moorabbin during the period of their appointment as Traffic Officers of the said municipality.

The appointment as Inspector (City of Knox) of Wilfred Thiele having been notified in Notice No. 111 contained in the *Victoria Government Gazette* No. 84 dated 15th October, 1975, is hereby revoked.

By order of the Transport Regulation Board,
 H. SHEAHAN, Secretary

Liquor Control Act 1968

APPOINTMENT OF LICENSING INSPECTORS

In accordance with the authority conferred upon me by sub-section (1) of section 22 of the *Liquor Control Act 1968*, I, Sinclair Imrie Miller, Chief Commissioner of Police, hereby appoint the following Officers of Police as Licensing Inspectors for the Divisions of the Police Districts as shown:—

Division Number	Police District	Rank and Name
1	Corangamite	Chief Inspector Donald Jeffery Johnson (<i>vice</i> Chief Superintendent W. E. Burns, Q.P.M.).
1	Glenelg	Chief Inspector George Bryan Hogg (<i>vice</i> Chief Superintendent P. F. Cashin, Q.P.M.).

S. I. MILLER,
 Chief Commissioner of Police
 8.9.1977

REVOCATION OF APPOINTMENTS

His Excellency the Governor of the State of Victoria, by and with the advice of the Executive Council thereof, has, by Orders made on the 6th day of September, 1977, revoked the appointments of the persons named hereunder to the offices mentioned, viz.:—

SOCIAL WELFARE DEPARTMENT

Honorary Probation Officers

FREDERICK ROY COOK,
 FRANCES MARY EARLS,
 GILLIAN HOCKING (Miss),
 MAXWELL HARTLEY LONSDALE,
 GEOFFREY WILLIAM RAWSON, and
 ROGER JOHN SWAIN,

as Honorary Probation Officers, pursuant to the provisions of section 507 (2) of the *Crimes Act 1958* and section 9 of the *Children's Court Act 1973* for all Adult and Children's Courts in Victoria.

TOM FORRISTAL,

Clerk of the Executive Council

At the Executive Council Chamber,
 Melbourne, 6th September, 1977

RESIGNATIONS

His Excellency the Governor of the State of Victoria, by and with the advice of the Executive Council thereof, has, by Orders made on the 6th day of September, 1977, accepted the resignations of the persons named hereunder of the offices mentioned, viz.:—

LAW DEPARTMENT

Commissioners for Taking Declarations, &c.

JAMES ALFRED TRAVIS COSSINS,
 JULIAN JOHN DOYLE, and
 MICHAEL DESMOND TORRENS,
 as Commissioners for Taking Declarations and Affidavits under the *Evidence Act 1958*.

Justice of the Peace

ARTHUR LESLEY COATES
 as a Justice of the Peace for the State of Victoria.

Examiner of Licensed Shorthand Writers

IVAN HARTLEY GREEN
 as an Examiner to conduct the examination of applicants for licences as shorthand writers, pursuant to section 139 of the *Evidence Act 1958*.

SOCIAL WELFARE DEPARTMENT

Honorary Probation Officers

EUGENE CAIRNS (Mr.), 38 Victoria Street, Mansfield,
 GORDON WARREN KEMLO (Rev.), Wesley Church, 136 Maude Street, Shepparton,
 CAROL B. KLOOGER (Mrs.), 47 Barton Street, Mont Albert,
 DOROTHY RUTH LARKINS (Mrs.), 35 Cherry Orchard Rise, Box Hill North,
 JOHN ALISTAIR KENNETH McLEAN (Rev.), 6 Pleasant Vale Crescent, Flora Hill, Bendigo,
 CHRIS FRANCIS PASCUZZI (Mr.), care of Mt. Newman Mining Co., Newman, Western Australia,
 DAWN STOUPPA (Mrs.), 67 Meadowgate Drive, Lilydale, and
 VERONICA MARY STYLES (Mrs.), 2 Station Street, Balaclava,
 as Honorary Probation Officers, pursuant to the provisions of section 507 (2) of the *Crimes Act 1958* and section 9 of the *Children's Court Act 1973*.

Probation and Parole Officer

GEORGINA HICKS
 as a Probation and Parole Officer, pursuant to the provisions of section 8 (2) of the *Children's Court Act 1973*, section 507 (1) of the *Crimes Act 1958* and sections 165 (1) and 189 (2) of the *Social Welfare Act 1970* (as amended).

TOM FORRISTAL,

Clerk of the Executive Council

At the Executive Council Chamber,
 Melbourne, 6th September, 1977

ORDERS IN COUNCIL

LOCAL GOVERNMENT DEPARTMENT

At the Executive Council Chamber, Melbourne, the sixth day of September, 1977

PRESENT:

His Excellency the Governor of Victoria
 Mr. Dickie | Mr. Balfour
 Mr. Maclellan | Mr. Hayes

ROADS DISCONTINUED—CITY OF OAKLEIGH

Whereas it is provided in section 528 (2) of the *Local Government Act 1958*, that where a road (whether or not a public highway but not being a road set out on land of the Crown) or any part thereof is not required for public use, the Governor in Council on the request of the council of the municipality in which such road is situated made not less than one month after publishing in a newspaper generally circulating in the district and posting to the registered proprietor (if any) of the land and the owners and occupiers (if any) of lands abutting or immediately adjacent to the road notice of intention to make such request may by Order published in the *Government Gazette* direct that such road or part shall be discontinued and thereupon such road or part shall be discontinued accordingly.

And whereas the Council of the City of Oakleigh has requested that the Governor in Council direct that roads off Howden Street, Oakleigh, be discontinued and not less than one month previously has published in a newspaper generally circulating in the district and posted to the registered proprietor of the land in the roads and to the owners and occupiers of lands abutting or immediately adjacent to the roads notice of intention to make such request.

Now therefore, His Excellency the Governor of the State of Victoria, by and with the advice of the Executive Council thereof, hereby directs:

- (a) that the said roads which are shown by hachure and cross hachure on the two plans hereunder, shall be discontinued;
- (b) that notwithstanding such discontinuance the Melbourne and Metropolitan Board of Works shall continue to have and possess the same right title power authority or interest in or in relation to the whole of the land shown by hachure and cross hachure on the said plans as it had or possessed prior to such discontinuance with respect to or in connection with any drains or pipes laid or erected in on or over such lands for the purpose of drainage or sewerage; and
- (c) that, subject to any such right title power authority or interest, the land in the said roads shown by hachure may be sold by the Council of the City of Oakleigh by agreement and the land in the said roads shown by cross hachure shall be retained by the Council of the City of Oakleigh for municipal purposes.

on the properties described in the Schedule hereunder which rate was made by the Council of the City of Sandringham on 14th December, 1976, for the purpose of providing off street parking facilities for use in connection with the Black Rock Shopping Centre.

SCHEDULE

1. Ebben Avenue, Black Rock, Nos. 2 and 4.
2. Balcombe Road, Black Rock, Nos. 611, 609, 607, 605, 603, 601, 599, 597, 595, 593, 591, 583-589, 614-612, 610, 608, 606, 604, 602, 600, 598, 596, 594, and 592.
3. Bluff Road, Black Rock, Nos. 1, 5, 7, 9-11, 13, 15, 17, 19, 21, 23, 25, 27, 29, 31, 33, 35, 39, 41, 41A, 2, 4, 6, 8, 10, 12, 14, 16, 18, 20, 22, 22A, 24-36, 38 and 40.
4. Beach Road, Black Rock, Nos. 297, 298, 299, 300-302, 303, 303A, 304, and 305.

And the Honorable Alan John Hunt, Her Majesty's Minister for Local Government for the State of Victoria, shall give the necessary directions herein accordingly.

TOM FORRISTAL,
Clerk of the Executive Council

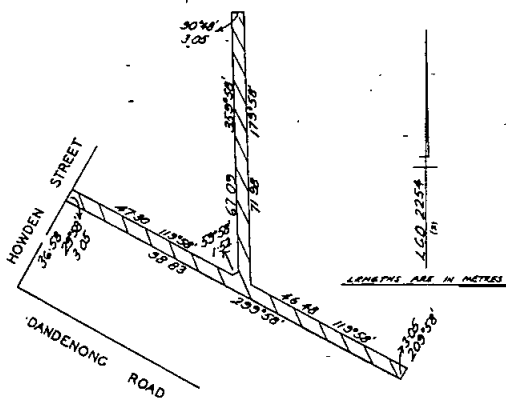
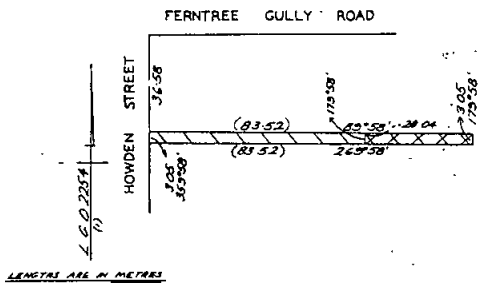

And the Honorable Alan John Hunt, Her Majesty's Minister for Local Government for the State of Victoria, shall give the necessary directions herein accordingly.

TOM FORRISTAL,
Clerk of the Executive Council

LOCAL GOVERNMENT DEPARTMENT

At the Executive Council Chamber, Melbourne, the sixth day of September, 1977

PRESENT:

- His Excellency the Governor of Victoria
- Mr. Dickie
- Mr. Maclellan
- Mr. Balfour
- Mr. Hayes

CONFIRMATION OF SEPARATE RATE—CITY OF SANDRINGHAM

In pursuance of the provisions of section 287 of the Local Government Act 1958, His Excellency the Governor of the State of Victoria, by and with the advice of the Executive Council thereof, hereby confirms a separate rate on the Site Value of the properties described hereunder, which rate was made by the Council of the City of Sandringham on 14th December, 1976, and to be levied at the various amounts in the dollar shown respectively against the said properties for the purpose of providing off-street parking facilities for use in connection with the Sandringham Shopping Centre:—

Rateable Property	Amount of Rate (cents)
1. Bay Road, Sandringham—	
(a) Nos. 8, 10, 10A, 12/14, 16, 18, 20, 22, 24/28, 30, 32, 34, 36, 7, 7A, 7B, 7C, 7D and 7E	1-50
(b) Nos. 9/13 (downstairs), 9/13 (upstairs), 15/17, 19, 21, 23, 25, 27, 29, 31, 38, 40, 42 and 44	1-125
(c) Nos. 33, 35, 56/60, 62, 64, 66, 68, 70 and 72	0-75
(d) No. 54	0-25
2. Station Street, Sandringham—	
(a) Nos. 50, 52, 54, 56, 58/60, 91, 93, 95, 90, 92, 94, 96, 98 and 98A	1-50
(b) Nos. 42/44, 46, 48, 62/64, 66, 68, 70, 72, 74, 78, 80, 82, 84, 86, 88, Railway Kiosk, 73, 79, 81, 83, 85, 87 and 89	1-125
(c) Nos. 18, 20/22, 24, 26, 28, 30, 32, 34, 36, 38 and 40	0-75
3. Waltham Street, Sandringham—	
(a) Nos. 22, 24, 32 and 34	1-50
(b) Nos. 1/7	1-125
4. Abbott Street, Sandringham—No. 24	0-75
5. Melrose Street, Sandringham—	
(a) Nos. 1/1A, 3, 5/13, 15, 17, 19, 21, 23, 25, 27, 29, 31, 33/35 (shop), 33/35 (upstairs), 37 and 39	1-50
(b) Nos. 12/16, 22 (property No. 1) and 22 (property No. 2)	1-125

LOCAL GOVERNMENT DEPARTMENT

At the Executive Council Chamber, Melbourne, the sixth day of September, 1977

PRESENT:

- His Excellency the Governor of Victoria
- Mr. Dickie
- Mr. Maclellan
- Mr. Balfour
- Mr. Hayes

CONFIRMATION OF SEPARATE RATE—CITY OF SANDRINGHAM

In pursuance of the provisions of section 287 of the Local Government Act 1958, His Excellency the Governor of the State of Victoria, by and with the advice of the Executive Council thereof, hereby confirms a separate rate of zero point seven two (0.72) cents in the dollar on the site value

Rateable Property	Amount of Rate (cents)
6. Sandringham Road, Sandringham—Nos. 2/8 ..	0.75
7. Kelly's Lane—14A Trentham Street, Sandringham	0.50
8. Beach Road, Sandringham—	
(a) Nos. 118/120	1.125
(b) No. 122	0.75

And the Honorable Alan John Hunt, Her Majesty's Minister for Local Government for the State of Victoria, shall give the necessary directions herein accordingly.

TOM FORRISTAL,
Clerk of the Executive Council

DEPARTMENT OF CROWN LANDS AND SURVEY

At the Executive Council Chamber, Melbourne, the sixth day of September, 1977

PRESENT:

His Excellency the Governor of Victoria
 Mr. Dickie Mr. Balfour
 Mr. Maclellan Mr. Hayes

LANDS TEMPORARILY RESERVED AS SITES

His Excellency the Governor of the State of Victoria, by and with the advice of the Executive Council thereof, doth hereby, in pursuance of section 14 of the Land Act 1958, reserve temporarily from sale, from being leased and from having a licence granted in respect thereof, and also except from occupation for mining purposes under any miner's right, the lands hereinafter described:—

MERBEIN.—Site for Public purposes (Sewerage purposes), 71.26 hectares, being Crown allotments 7, 10A and 10B, section B, Parish of Merbein, County of Karkaroc as indicated by hatching on plan hereunder.—(M.572(°) (Rs.10359).

MOREEP.—Site for Water Supply purposes, 58.62 hectares, being Crown allotments 57 and 58, Parish of Moreep, County of Grant as indicated by hatching on plan hereunder.—(M.468(°) (Rs.10382).

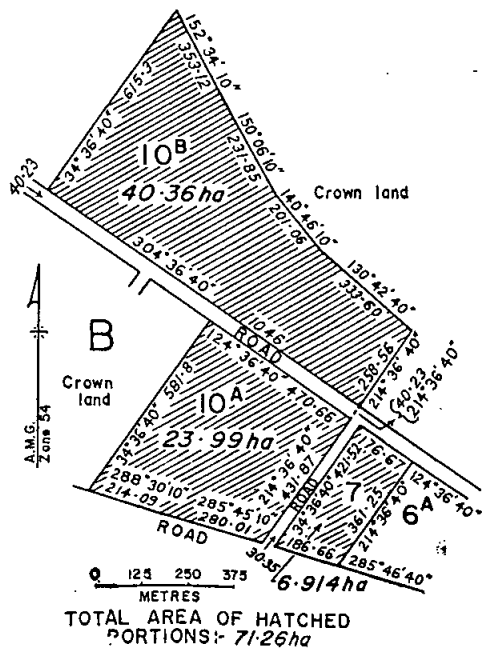
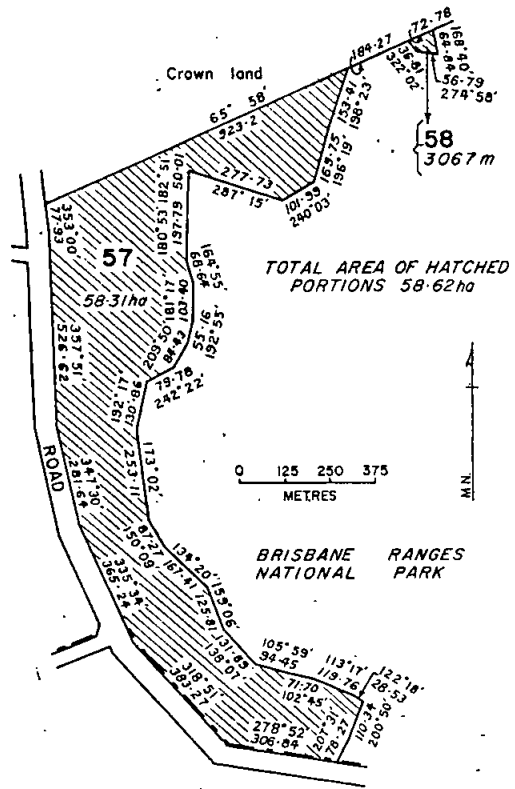

MOOROOPNA WEST (MERRIGUM).—Site for Public purposes (Public Hall), 2003 square metres, being Crown allotment 86B, Parish of Mooropna West, County of Rodney as indicated by hatching on plan hereunder.—(M.458(14) (Rs.10321).

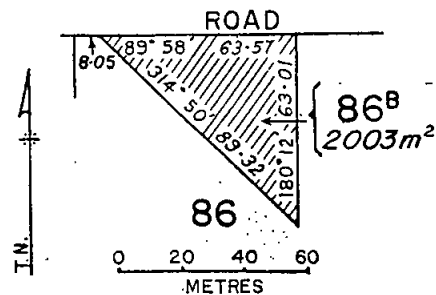

OUYEN.—Site for Public purposes (Departmental Depot), 3775 square metres, being Crown allotment 33, section 16, Township of Ouyen, Parish of Ouyen, County of Karkaroc as indicated by hatching on plan hereunder.—(O.22^(*)) (Rs.10384).

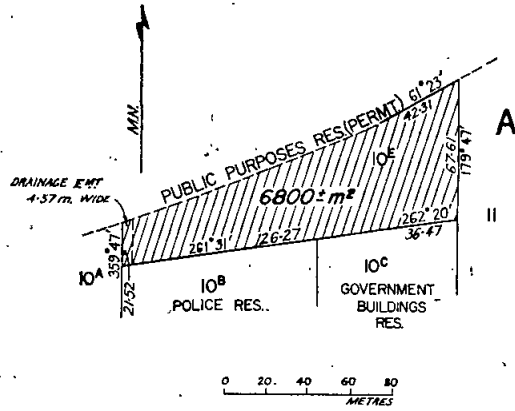
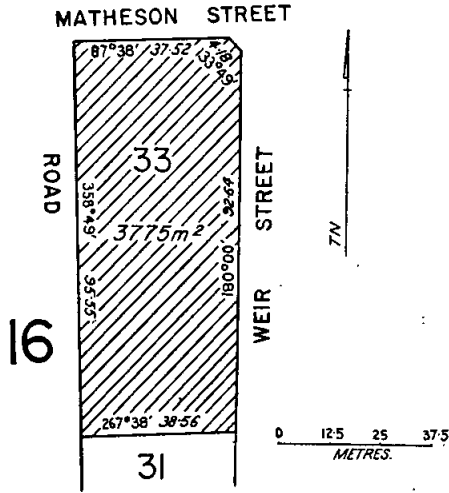

STAWELL.—Site for Public Park and Recreation, 2032 square metres, being Crown allotments 3 and 7, section 114, Parish of Stawell, County of Borung as indicated by hatching on plan hereunder.—S.329^(1*) (Rs.3647).

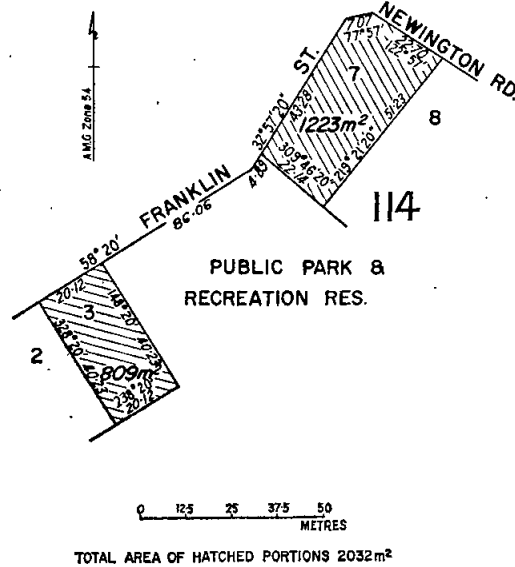

PORT CAMPBELL.—Site for Public purposes (Historical purposes), 2023 square metres, being Crown allotment 7, section 8, Township of Port Campbell, Parish of Paaratte, County of Heytesbury as indicated by hatching on plan hereunder.—(P.147^(*)) (Rs.3505).

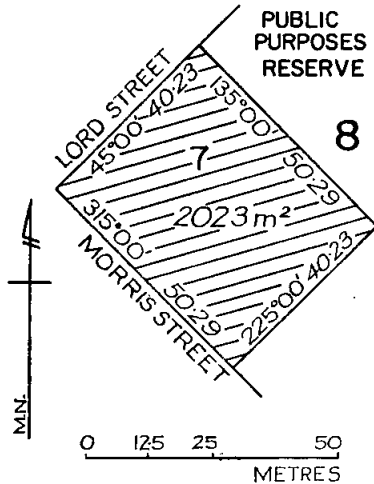

TALGARNO.—Site for Public purposes (Conservation of Native Bushland), 30.38 hectares, being Crown allotment 2A, section D, Parish of Talgaro, County of Benambra as indicated by hatching on plan hereunder.—(T.62^(*)) (Rs.1547).

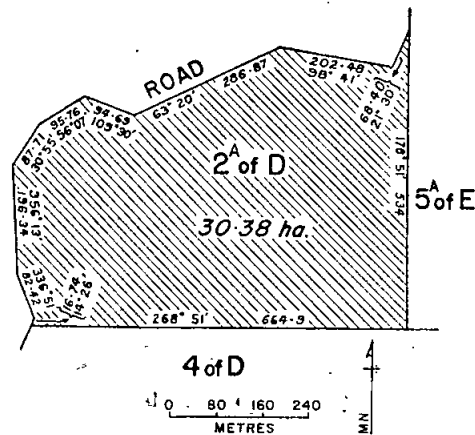

SAN REMO.—Site for Public purposes, 6800 square metres, more or less, being Crown allotment 10E, section A, Township of San Remo, Parish of Woolamai, County of Mornington as indicated by hatching on plan hereunder.—(S.463^(*)) (Rs.3017).

TARWIN LOWER.—Site for Public purposes (Preservation of Native Flora), 6.278 hectares, being Crown allotment 12, section 3, Township of Tarwin Lower, Parish of Tarwin, County of Buln Buln as indicated by hatching on plan hereunder.—T.191⁽¹¹⁾ (Rs.10459).

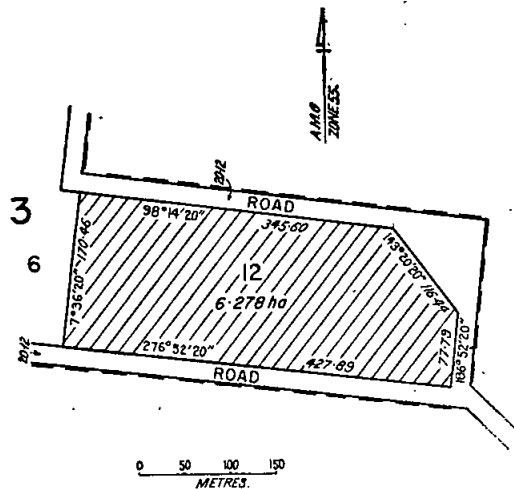

And the Honorable William Archibald Borthwick, Her Majesty's Minister of Lands for the State of Victoria, shall give the necessary directions herein accordingly.

TOM FORRISTAL,
Clerk of the Executive Council

LAND ACT 1958

At the Executive Council Chamber, Melbourne, the sixth day of September, 1977

PRESENT:

His Excellency the Governor of Victoria
Mr. Dickie | Mr. Balfour
Mr. Maclellan | Mr. Hayes

REVOCATION OF TEMPORARY RESERVATION OF SITE BY ORDER IN COUNCIL

His Excellency the Governor of the State of Victoria in the Commonwealth of Australia, by and with the advice of the Executive Council of the said State, pursuant to the provisions of the Land Act 1958, hereby revokes the temporary reservation of land by Order in Council herein after described:

BINGINWARRI.—The temporary reservation by Order in Council of the 9th May, 1906, of 2504 square metres of land adjoining Crown allotment 65K, Parish of Binginwarrri, as a site for a Public Hall.—(B.707⁽¹²⁾) (Rs.1448).

And the Honorable William Archibald Borthwick, Her Majesty's Minister of Lands for the State of Victoria, shall give the necessary directions herein accordingly.

TOM FORRISTAL,
Clerk of the Executive Council

DEPARTMENT OF CROWN LANDS AND SURVEY

At the Executive Council Chamber, Melbourne, the sixth day of September, 1977

PRESENT:

His Excellency the Governor of Victoria
Mr. Dickie | Mr. Balfour
Mr. Maclellan | Mr. Hayes

LAND TEMPORARILY RESERVED AS A SITE

His Excellency the Governor of the State of Victoria, by and with the advice of the Executive Council thereof, doth hereby, in pursuance of section 14 of the Land Act

1958; reserve temporarily from sale; from being leased and from having a licence granted in respect thereof, and also except from occupation for mining purposes under any miner's right, the land hereinafter described:—

COLQUHOUN.—Site for Public Purposes (Conservation of an Area of Natural Interest and Ecological Significance and Provision of a Centre for Environmental Education including Field Research), 178 hectares, being Crown allotments 11A, 13B, 14B and 104C, Parish of Colquhoun, County of Tambo, as indicated by hatching on plan hereunder.—(C.383⁽¹¹⁾) (Rs.10405).

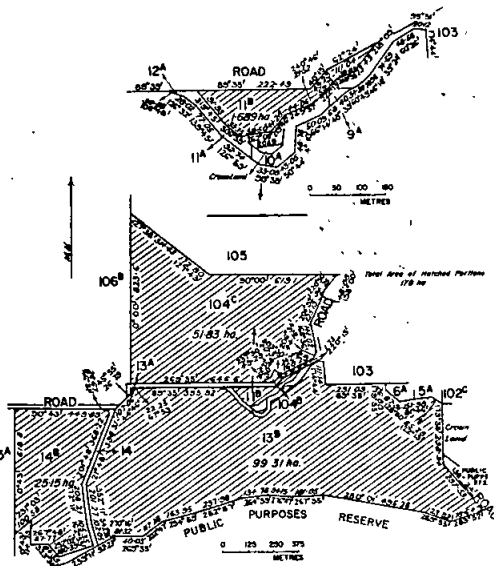

And the Honorable William Archibald Borthwick, Her Majesty's Minister of Lands for the State of Victoria, shall give the necessary directions herein accordingly.

TOM FORRISTAL,
Clerk of the Executive Council

HOUSING ACT 1958

At the Executive Council Chamber, Melbourne, the sixth day of September, 1977

PRESENT:

His Excellency the Governor of Victoria
Mr. Dickie | Mr. Balfour
Mr. Maclellan | Mr. Hayes

DECLARATION OF PRIVATE STREETS AS PUBLIC HIGHWAYS WITHIN THE CITY OF BROADMEADOWS

Whereas pursuant to Section 107 of the Housing Act 1958 it is among other things enacted that where works have been carried out in accordance with an agreement for the full construction of any roads, pavements, culverts or drains made pursuant to the provisions of the said Section 107 such roads, pavements, culverts or drains shall be under the care and management of the Municipality which shall be liable for the cost of any maintenance, repair, alteration or reconstruction thereof and the Governor-in-Council may by order published in the Government Gazette declare any road so constructed to be a public highway.

And whereas by Order dated the 18th January 1977, the Governor-in-Council consented to an agreement between the Housing Commission and the City of Broadmeadows regarding street and drainage construction in Erinbank Crescent, Redan Court, Kernot Court, Gorae Court, Lima Court, Walpa Court, Dooen Court, Linga Street, Toora Drive, Rhyll Court, Devenish Court, Musk Court, Patho Court, Iona Court, Brim Court, Hesse Court and Natya Court in the Broadmeadows "J" Estate situate in the municipality of the City of Broadmeadows and the carrying out of the works enumerated in the said Agreement.

And whereas the works of road pavements, culvert and drainage construction have now been carried out in accordance with the said agreement between the Housing Commission and the City of Broadmeadows.

Now therefore His Excellency the Governor of the State of Victoria by and with the advice of the Executive Council of the said State and in pursuance of the powers conferred by Section 107 of the Housing Act and upon recommendation of the Housing Commission doth by this order declare the streets more particularly delineated and shown hatched on the plans hereunder to be absolutely dedicated to the public as Public Highways within the meaning of any law now or hereafter in force and that the Council of the Municipality in which the streets are situate shall hereafter be liable for all cost of any maintenance, repair, alteration or reconstruction thereof.

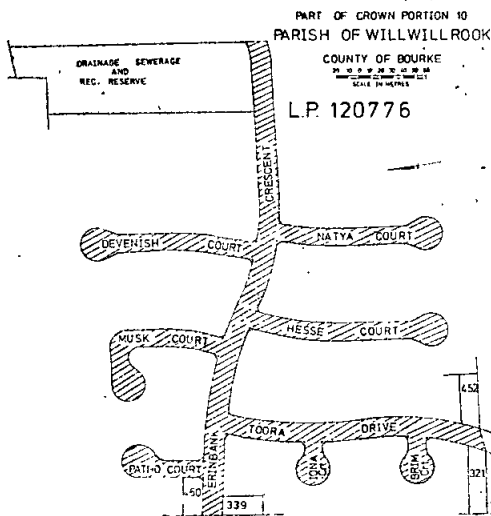
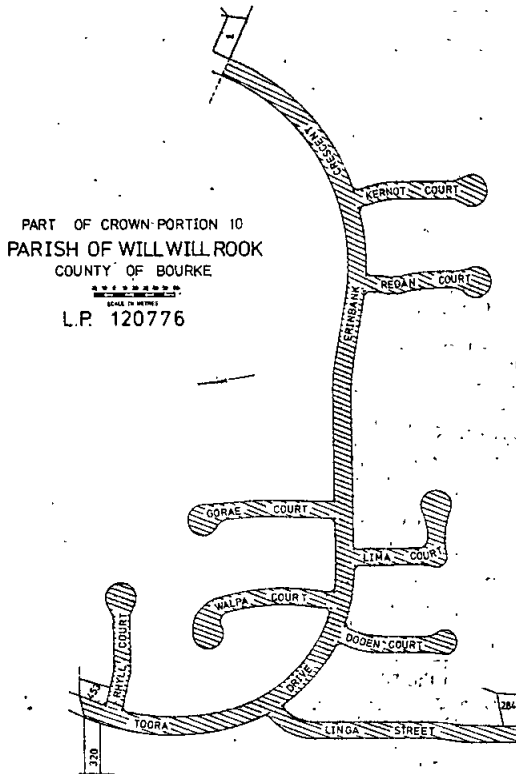

And the Honorable Geoffrey Phillip Hayes, Her Majesty's Minister of Housing for the State of Victoria shall give the necessary directions herein accordingly.

TOM FORRISTAL,
Clerk of the Executive Council

HOUSING ACT 1958

At the Executive Council Chamber, Melbourne, the sixth day of September, 1977

PRESENT:

His Excellency the Governor of Victoria
Mr. Dickie Mr. Balfour
Mr. Maclellan Mr. Hayes

DECLARATION OF PRIVATE STREETS AS PUBLIC HIGHWAYS WITHIN THE CITY OF SUNSHINE

Whereas pursuant to Section 107 of the Housing Act 1958 it is among other things enacted that where works have been carried out in accordance with an agreement for the full construction of any roads, pavements, culverts or drains made pursuant to the provisions of the said Section 107 such roads, pavements, culverts or drains shall be under the care and management of the Municipality which shall be liable for the cost of any maintenance, repair, alteration or reconstruction thereof and the Governor in Council may by order published in the Government Gazette declare any road so constructed to be a public highway.

And whereas by Order dated the 29th June 1971, the Governor in Council consented to an agreement between the Housing Commission and the City of Sunshine regarding street and drainage construction in Tallintyre Road, Barnes Crescent, Cawood Drive, Mourell Street, Valentine Crescent, Oakes Court and Jones Court in the Glen Gala Estate situate in the municipality of the City of Sunshine and the carrying out of the works enumerated in the said Agreement.

And whereas the works of road pavements, culvert and drainage construction have now been carried out in accordance with the said agreement, between the Housing Commission and the City of Sunshine.

Now therefore His Excellency the Governor of the State of Victoria by and with the advice of the Executive Council of the said State and in pursuance of the powers conferred by Section 107 of the Housing Act and upon recommendation of the Housing Commission doth by this order declare the streets more particularly delineated and shown hatched on the plan hereunder to be absolutely dedicated to the public as Public Highways within the meaning of law now or hereafter in force and that the Council of the Municipality in which the streets are situate shall hereafter be liable for all cost of any maintenance, repair, alteration or reconstruction thereof.

PARISH OF DERRIMUT
COUNTY OF BOURKE
Scale 1:10000

L.P. 97545

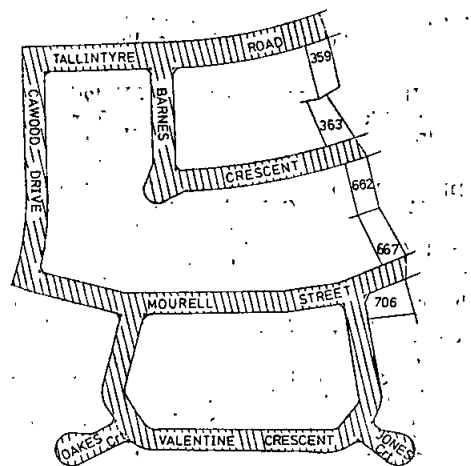

And the Honorable Geoffrey Phillip Hayes, Her Majesty's Minister of Housing for the State of Victoria shall give the necessary directions herein accordingly.

TOM FORRISTAL,
Clerk of the Executive Council

SOIL CONSERVATION AND LAND UTILIZATION
ACT 1958

At the Executive Council Chamber, Melbourne, the
sixth day of September, 1977

PRESENT:

His Excellency the Governor of Victoria
Mr. Dickie | Mr. Balfour
Mr. Maclellan | Mr. Hayes

DISTRICT ADVISORY COMMITTEE—AVOCA RIVER
SOIL CONSERVATION DISTRICT

In pursuance of the powers conferred by section 15 of the Soil Conservation and Land Utilization Act, His Excellency the Governor of the State of Victoria by and with the advice of the Executive Council thereof doth hereby appoint the following persons to be members of the District Advisory Committee of the Avoca River Soil Conservation District for a term of three years.

FRANK OSWALD SANDERSON, being a person elected to represent grazing, agricultural and other relevant interests in the District.

ALLAN SMALL, being a person elected to represent grazing, agricultural and other relevant interests in the District.

JOHN WILLIAM RADFORD, being a person elected to represent grazing, agricultural and other relevant interests in the District.

ALAN MORESI SCOTT, being a person elected to represent grazing, agricultural and other relevant interests in the District.

BRYAN CLIVE CURNOW, being the person representing the Department of Agriculture.

RODNEY WILLIAM HANDMER, being the person representing the Forests Commission.

ROBERT FRANCIS CHAFFE, being the person representing the Soil Conservation Authority.

And the Honorable William Archibald Borthwick, Her Majesty's Minister for Conservation for the State of Victoria, shall give the necessary directions herein accordingly.

TOM FORRISTAL,
Clerk of the Executive Council

SOIL CONSERVATION AND LAND UTILIZATION
ACT 1958

At the Executive Council Chamber, Melbourne, the
sixth day of September, 1977

PRESENT:

His Excellency the Governor of Victoria
Mr. Dickie | Mr. Balfour
Mr. Maclellan | Mr. Hayes

DISTRICT ADVISORY COMMITTEE—EASTERN
MALLEE SOIL CONSERVATION DISTRICT

In pursuance of the powers conferred by section 15 of the Soil Conservation and Land Utilization Act, His Excellency the Governor of the State of Victoria by and with the advice of the Executive Council thereof doth hereby appoint the following persons to be members of the District Advisory Committee of the Eastern Mallee Soil Conservation District for a term of three years.

GEORGE ANDREW CULLINAN, being a person elected to represent grazing, agricultural and other relevant interests in the District.

RAYMOND FREDERICK GORMANN, being a person elected to represent grazing, agricultural and other relevant interests in the District.

EDWARD LESLIE PAY, being a person elected to represent grazing, agricultural and other relevant interests in the District.

JAMES HENRY WRIGHT, being a person elected to represent grazing, agricultural and other relevant interests in the District.

NORMAN KENNETH MCSWAIN, being the person representing the Department of Agriculture.

KEITH MCKENZIE MILLS, being the person representing the State Rivers and Water Supply Commission.

THOMAS WILLIAM SPEEDIE, being the person representing the Soil Conservation Authority.

And the Honorable William Archibald Borthwick, Her Majesty's Minister for Conservation for the State of Victoria, shall give the necessary directions herein accordingly.

TOM FORRISTAL,
Clerk of the Executive Council

SOIL CONSERVATION AND LAND UTILIZATION
ACT 1958

At the Executive Council Chamber, Melbourne, the
sixth day of September, 1977

PRESENT:

His Excellency the Governor of Victoria
Mr. Dickie | Mr. Balfour
Mr. Maclellan | Mr. Hayes

DISTRICT ADVISORY COMMITTEE—UPPER
GOULBURN SOIL CONSERVATION DISTRICT

In pursuance of the powers conferred by section 15 of the Soil Conservation and Land Utilization Act, His Excellency the Governor of the State of Victoria by and with the advice of the Executive Council thereof doth hereby appoint the following persons to be members of the District Advisory Committee of the Upper Goulburn Soil Conservation District for a term of three years.

PETER OWEN MILLER, being a person elected to represent grazing, agricultural and other relevant interests in the District.

KENNETH WEBB WARE, being a person elected to represent grazing, agricultural and other relevant interests in the District.

GEOFFREY AUSTIN SCOTT, being a person elected to represent grazing, agricultural and other relevant interests in the District.

JAMES TEHAN, being a person elected to represent grazing, agricultural and other relevant interests in the District.

DAVID JOHN CANNON, being the person representing the Department of Agriculture.

HARRY BARNETT PREWETT, being the person representing the Forests Commission.

DENIS FRANK MARTIN, being the person representing the Soil Conservation Authority.

And the Honorable William Archibald Borthwick, Her Majesty's Minister for Conservation for the State of Victoria, shall give the necessary directions herein accordingly.

TOM FORRISTAL,
Clerk of the Executive Council

SOIL CONSERVATION AND LAND UTILIZATION ACT
1958

At the Executive Council Chamber, Melbourne, the
sixth day of September, 1977

PRESENT:

His Excellency the Governor of Victoria
Mr. Dickie | Mr. Balfour
Mr. Maclellan | Mr. Hayes

DISTRICT ADVISORY COMMITTEE—
MOORABOOL SOIL CONSERVATION DISTRICT

In pursuance of the powers conferred by section 15 of the Soil Conservation and Land Utilization Act, His Excellency the Governor of the State of Victoria by and with the advice of the Executive Council thereof, doth hereby appoint the following persons to be members of the District Advisory Committee of the Moorabool Soil Conservation District for a term of three years.

GRAHAM DOUGLAS SIMPSON, being a person elected to represent grazing, agricultural and other relevant interests in the District.

HERBERT ARTHUR BOARDMAN, being a person elected to represent grazing, agricultural and other relevant interests in the District.

JAMES GEOFFREY HENDERSON, being a person elected to represent grazing, agricultural and other relevant interests in the District.

ALISON HARRIS, being the person representing the Town and Country Planning Board.

ROBERT McDONALD MOODIE, being the person representing the Soil Conservation Authority.

And the Honorable William Archibald Borthwick, Her Majesty's Minister for Conservation for the State of Victoria, shall give the necessary directions herein accordingly.

TOM FORRISTAL,
Clerk of the Executive Council

FORESTS ACT 1958

At the Executive Council Chamber, Melbourne, the sixth day of September, 1977

PRESENT:

His Excellency the Governor of Victoria
Mr. Dickie | Mr. Balfour
Mr. Maclellan | Mr. Hayes

ALIENATED LAND ACQUIRED BY EXCHANGE, ETC., AND DEDICATED AS RESERVED FOREST

Whereas by section 42, sub-section 8, of the Forests Act 1958, it is prescribed that the Governor in Council may acquire by exchange of land dedicated as reserved forest—

- (a) any alienated land or Crown land licensed or leased with an inchoate right of purchase; or
- (b) any land, public or private, and whether vested in trustees or otherwise;

and may by order published in the *Government Gazette* dedicate the same as reserved forest:

Now therefore, His Excellency the Governor of the State of Victoria, by and with the advice of the Executive Council of the said State, and in pursuance of the provisions of section 42, sub-section 8, of the Forests Act 1958, doth by this Order—

- (1) acquire the alienated land described in Schedule "A" hereto by exchange of land dedicated as reserved forest described in Schedule "B" hereto;
- (2) excise from the reserved forest and alienate the area described in the aforesaid Schedule "B", such excision and alienation to take effect 30 days from date hereof;
- (3) dedicate the land described in Schedule "A" aforementioned as reserved forest, such dedication to take effect 30 days from date hereof.

SCHEDULE "A"—DEDICATION SCHEDULE NO. 228

Alienated land acquired from Zigmunds Inge and Alexander Adam Inge, being part of lot 2 on Plan of Subdivision No. 93045, being part of Crown Allotment 11E, Parish of Buxton, County of Anglesey comprising 16.90 hectares and being part of the land described in certificate of title, volume 8905, folio 915, and shown more particularly on Forest Commission Survey Plan No. S-1004.

SCHEDULE "B"—EXCISION SCHEDULE NO. 187

Land excised from the Reserved Forest for Zigmunds Inge and Alexander Adam Inge, being 40.45 hectares in the Parish of Mohican, County of Anglesey, shown on Forests Commission Survey Plan No. S-1067.

And the Honorable Frederick James Granter, Her Majesty's Minister of Forests for the State of Victoria shall give the necessary directions herein accordingly.

TOM FORRISTAL,
Clerk of the Executive Council

HOSPITALS AND CHARITIES ACT 1958, SECTIONS 46 AND 64

At the Executive Council Chamber, Melbourne, the sixth day of September, 1977

PRESENT:

His Excellency the Governor of Victoria
Mr. Dickie | Mr. Balfour
Mr. Maclellan | Mr. Hayes

ORDER INCORPORATING EAGLEHAWK AND LONG GULLY COMMUNITY HEALTH CENTRE

Whereas a petition signed by not less than twenty-five contributors to the Eaglehawk and Long Gully Community Health Centre a benevolent society capable of incorporation under the *Hospitals and Charities Act 1958*, praying that the benevolent society be incorporated has been received by the Hospitals and Charities Commission:

And whereas the substance or prayer of the said petition has been published in the *Government Gazette* of 6th July, 1977:

And whereas no counter petition signed by an equal or greater number of contributors to the said benevolent society has been lodged with the Hospitals and Charities Commission within one month after the date of publication aforesaid:

Now therefore His Excellency the Governor of the State of Victoria in the Commonwealth of Australia by and with the advice of the Executive Council of the said State doth hereby declare that the contributors for the time being to the said benevolent society shall be a body corporate by the name of Eaglehawk and Long Gully Community Health Centre with the following objects:—

- (a) To manage and maintain a Community Health Centre in Eaglehawk and Long Gully which will provide facilities for family physicians, specialists, dentists, medical and community nurses, physiotherapists, occupational therapists, social workers, psychiatric nurses and other medical and/or para-medical personnel as are required.
- (b) To provide facilities for diagnosis and treatment of illness and for provision of preventive health services for all persons including those in necessitous circumstances.
- (c) To provide for the teaching of community health care to students and practising health and welfare personnel.
- (d) To provide facilities for child care services in Eaglehawk and Long Gully.
- (e) To purchase or acquire any real and/or personal property and other buildings to be used for the above purposes.
- (f) To do all such other things as are incidental or conducive to the attainment of the above objects.

And the Honorable William Vasey Houghton, Her Majesty's Minister of Health for the State of Victoria shall give the necessary directions herein accordingly.

TOM FORRISTAL,
Clerk of the Executive Council

SUPERANNUATION ACT 1958

At the Executive Council Chamber, Melbourne, the sixth day of September, 1977

PRESENT:

His Excellency the Governor of Victoria
Mr. Dickie | Mr. Balfour
Mr. Maclellan | Mr. Hayes

Pursuant to the powers conferred by the provisions of paragraph (ja) of sub-section (1) of section 3 of the *Superannuation Act 1958*, His Excellency the Governor of the State of Victoria, by and with the advice of the Executive Council thereof, doth by this Order declare that the provisions of the *Superannuation Act* shall apply to Alfred James Ellwood, Chairman of a Land Valuation Board of Review, as from and inclusive of 30th September, 1977.

And the Honorable Rupert James Hamer, Her Majesty's Treasurer for the State of Victoria, shall give the necessary directions herein accordingly.

TOM FORRISTAL,
Clerk of the Executive Council

SUPERANNUATION ACT 1958

At the Executive Council Chamber, Melbourne, the sixth day of September, 1977

PRESENT:

His Excellency the Governor of Victoria
 Mr. Dickie | Mr. Balfour
 Mr. Maclellan | Mr. Hayes

Pursuant to the powers conferred by the provisions of paragraph (ja) of sub-section (1) of section 3 of the Superannuation Act 1958, His Excellency the Governor of the State of Victoria, by and with the advice of the Executive Council thereof, doth by this Order declare that the provisions of the Superannuation Act shall apply to the officers named in the schedule set out hereunder.

SCHEDULE

IAN WILLIAM ROBERTS, Gippsland Institute of Advanced Education.
 JUDITH HELEN ALEXANDER, the Victorian College of the Arts.
 SUSAN ELLEN HEPWORTH, the Victorian College of the Arts.
 JOHN WILLIAM TALBOT, the Victorian College of the Arts.
 MERVYN KILMARTIN TRIM, the Victorian College of the Arts.

And the Honorable Rupert James Hamer, Her Majesty's Treasurer for the State of Victoria, shall give the necessary directions herein accordingly.

TOM FORRISTAL,
 Clerk of the Executive Council

HISTORIC BUILDINGS ACT 1974 (No. 8569)

At the Executive Council Chamber, Melbourne, the sixth day of September, 1977

PRESENT:

His Excellency the Governor of Victoria
 Mr. Dickie | Mr. Balfour
 Mr. Maclellan | Mr. Hayes

AMENDMENT OF REGISTER OF HISTORIC BUILDINGS

Whereas it is provided by section 3 of the *Historic Buildings Act 1974* that the Governor in Council, on the recommendation of the Minister, may by notice published in the *Government Gazette* amend the Register of Historic Buildings established under the said Act—

- (a) by adding any specified building;
- (b) by removing any specified building; or
- (c) by altering any item.

And whereas the Minister has recommended that the Register be amended, now therefore His Excellency the Governor of the State of Victoria, by and with the advice of the Executive Council thereof, doth hereby amend the Register of Historic Buildings in the manner and to the extent shown as follows:—

by altering item No. 24 to read "No. 24 Carlton Brewery (the exterior only of the bluestone building which fronts Victoria, Bouverie and Old Ballarat Streets) Bouverie Street, Carlton."

And the Honorable Geoffrey Phillip Hayes, Her Majesty's Minister for Planning for the State of Victoria, shall give the necessary directions herein accordingly.

TOM FORRISTAL,
 Clerk of the Executive Council

HISTORIC BUILDINGS ACT 1974 (No. 8569)

At the Executive Council Chamber, Melbourne, the sixth day of September, 1977

PRESENT:

His Excellency the Governor of Victoria
 Mr. Dickie | Mr. Balfour
 Mr. Maclellan | Mr. Hayes

AMENDMENT OF REGISTER OF HISTORIC BUILDINGS

Whereas it is provided by section 3 of the *Historic Buildings Act 1974* that the Governor in Council, on the recommendation of the Minister, may by notice published in the *Government Gazette* amend the Register of Historic Buildings established under the said Act—

- (a) by adding any specified building;
- (b) by removing any specified building; or
- (c) by altering any item.

And whereas the Minister has recommended that the Register be amended now therefore His Excellency the Governor of the State of Victoria, by and with the advice of the Executive Council thereof, doth hereby amend the Register of Historic Buildings in the manner and to the extent shown as follows, by adding:—

"No. 411 Manchester Unity Building, 220-226 Swanston Street Melbourne, to the extent of the street facades to Swanston and Collins Street, the total tower, the interior of the ground floor arcade and the boardroom."

And the Honorable Geoffrey Phillip Hayes, Her Majesty's Minister for Planning for the State of Victoria, shall give the necessary directions herein accordingly.

TOM FORRISTAL,
 Clerk of the Executive Council

HISTORIC BUILDINGS ACT 1974 (No. 8569)

At the Executive Council Chamber, Melbourne, the sixth day of September, 1977

PRESENT:

His Excellency the Governor of Victoria
 Mr. Dickie | Mr. Balfour
 Mr. Maclellan | Mr. Hayes

AMENDMENT OF REGISTER OF HISTORIC BUILDINGS

Whereas it is provided by section 3 of the *Historic Buildings Act 1974* that the Governor in Council, on the recommendation of the Minister, may by notice published in the *Government Gazette* amend the Register of Historic Buildings established under the said Act—

- (a) by adding any specified building;
- (b) by removing any specified building; or
- (c) by altering any item.

And whereas the Minister has recommended that the Register be amended now therefore His Excellency the Governor of the State of Victoria, by and with the advice of the Executive Council thereof, doth hereby amend the Register of Historic Buildings in the manner and to the extent shown as follows:—

by altering item No. 27 to read "No. 27 Bishops Court (excluding the red brick addition to the original bluestone building), 120 Clarendon Street, East Melbourne."

And the Honorable Geoffrey Phillip Hayes, Her Majesty's Minister for Planning for the State of Victoria, shall give the necessary directions herein accordingly.

TOM FORRISTAL,
 Clerk of the Executive Council

COLAC WATERWORKS TRUST

At the Executive Council Chamber, Melbourne, the sixth day of September, 1977

PRESENT:

His Excellency the Governor of Victoria
 Mr. Dickie | Mr. Balfour
 Mr. Maclellan | Mr. Hayes

SALE OF LAND

Under the powers conferred by the Water Act and all other powers enabling him in that behalf, His Excellency the Governor of the State of Victoria, by and with the advice of the Executive Council of the said State, doth hereby approve of the sale by the Colac Waterworks Trust of part of Crown allotment 20, Parish of Olangolah, County of Polwarth, being part of the land comprised in Certificate of Title, Volume 6413, Folio 455 as shown by red colour on a plan, deposited in the office of the State Rivers and Water Supply Commission, Melbourne (Corr. No. 76/3033/12).

And the Honorable Frederick James Granter, Her Majesty's Minister of Water Supply for the State of Victoria, shall give the necessary directions herein accordingly.

TOM FORRISTAL,
 Clerk of the Executive Council

LATROBE VALLEY WATER AND SEWERAGE BOARD

At the Executive Council Chamber, Melbourne, the thirteenth day of September, 1977

PRESENT:

His Excellency the Governor of Victoria
 Mr. Borthwick | Mr. Rafferty
 Mr. Houghton | Mr. Crozier

CONSENT TO BORROWING \$350,000

Under the powers conferred by the Latrobe Valley Act and all other powers enabling him in that behalf, His Excellency the Governor of the State of Victoria, by and with the advice of the Executive Council of the said State, hereby consents to the Latrobe Valley Water and Sewerage Board borrowing the sum of Three hundred and fifty thousand dollars (\$350,000) in two separate loans of Two hundred and fifty thousand dollars (\$250,000) and One hundred thousand dollars (\$100,000) to meet the cost of water supply and sewerage works.

And the Honorable Frederick James Granter, Her Majesty's Minister of Water Supply for the State of Victoria, shall give the necessary directions herein accordingly.

TOM FORRISTAL,
 Clerk of the Executive Council

FRANKSTON SEWERAGE AUTHORITY

At the Executive Council Chamber, Melbourne, the thirteenth day of September, 1977

PRESENT:

His Excellency the Governor of Victoria
 Mr. Borthwick | Mr. Rafferty
 Mr. Houghton | Mr. Crozier

CONSENT TO BORROWING \$400,000

Under the powers conferred by the Sewerage Districts Act and all other powers enabling him in that behalf, His Excellency the Governor of the State of Victoria, by and with the advice of the Executive Council of the said State hereby consents to the Frankston Sewerage Authority

borrowing the sum of Four hundred thousand dollars (\$400,000), in two separate loans of Two hundred thousand dollars (\$200,000) to meet the cost of sewerage works as set forth in the detailed statement bearing date 8th September, 1977.

And the Honorable Frederick James Granter, Her Majesty's Minister of Water Supply for the State of Victoria, shall give the necessary directions herein accordingly.

TOM FORRISTAL,
 Clerk of the Executive Council

LANDS DEPARTMENT NOTICES

APPROACHING LAND SALES

Sale of Crown Land, in fee-simple, will be held at the under-mentioned places and dates, viz:—

	No. of Gazette
Mildura.—Saturday, 17th September, 1977	.. 71
Ouyen.—Friday, 9th September, 1977	.. 68
Wonthaggi.—Monday, 24th October, 1977	.. 76

SALE OF CROWN LAND BY AUCTION

The land will be offered for sale in fee-simple, and subject to the provisions of the Land Act and Regulations thereunder.

The upset price is the sum at which bidding will start, and no bid below that sum can be accepted. The highest bidder at or above that sum shall be the purchaser, subject to signature of contract and any necessary payment.

TERMS:—

A deposit of at least 12½% of the purchase price must be paid at the sale, either in cash or by cheque.

The residue is payable in half-yearly instalments, in accordance with the following scale, or may be paid off at any earlier time.

Over \$40, and not exceeding \$100,	8 instalments.
Over \$100, and not exceeding \$200,	10 instalments.
Over \$200, and not exceeding \$400,	12 instalments.
Over \$400, and not exceeding \$600,	14 instalments.
Over \$600, and not exceeding \$800,	16 instalments.
Over \$800, and not exceeding \$1,000,	18 instalments.
Over \$1,000,	20 instalments.

Interest at the rate of 9% per annum is payable with all payments of residue, and is computed for each instalment from the date of sale to the date of such payment. Additional interest is charged if any instalment is not paid on or before the due date.

If paid off within 30 days of sale, no interest is payable.

FEES, ETC.:

Also payable at the sale, in addition to the deposit, are the survey fee and, if applicable, the valuation of improvements (if purchaser be not the owner thereof).

Payable with balance of purchase money—
 Crown Grant fee—\$18.00.

Assurance Fund contribution.—One cent in every Five dollars or part thereof of purchase price. (This is a fund established to guarantee the validity of freehold titles.)

Transfer of interest prior to completion of payment may be allowed on payment of \$12 fee and subject to stamp duty.

If unable to attend personally, a prospective purchaser may arrange for another person to bid as his agent.

Attention is drawn to section 95, Land Act 1958, which provides that the purchaser shall be deemed to be the owner for the purposes of other Acts; also to an amendment to the Local Government Act providing for Government roads, in certain circumstances, to be declared "private streets", thus making the purchaser liable to contribute to the cost of street construction.

W. BORTHWICK,
 Minister of Lands
 Office of Crown Lands and Survey,
 Melbourne, 14th September, 1977

WONTHAGGI.—Sale (No. 12242) of Crown Land in fee simple, by auction, will be held at the TOWN HALL, WONTHAGGI on MONDAY the 24th day of OCTOBER, 1977, at ELEVEN o'clock A.M. To be conducted by P. K. Coghlan, Land Officer, Melbourne.

Lot 1

PARISH OF WONTHAGGI

Fronting the west side of Cassia Street, Cape Paterson

Upset price \$2,500.00 the lot. Survey fee \$120.00

Area 36 perches (910 square metres). Allotment 20 of Section D. Subject to drainage easement 10 links (2.01 metres) wide.

Lot 2

Upset price \$1,500.00 the lot. Survey fee \$120.00

Area 36 perches (910 square metres). Allotment 21 of Section D. Subject to drainage easement 10 links (2.01 metres) wide. One month allowed for removal of improvements (fencing).

Lot 3

Upset price \$1,000.00 the lot. Survey fee \$120.00

Area 36 perches (910 square metres). Allotment 22 of Section D. Subject to drainage easement 10 links (2.01 metres) wide. One month allowed for removal of improvements (fencing).

Lot 4

Fronting the west side of Sheoke Street, Cape Paterson

Upset price \$3,000.00 the lot. Survey fee \$120.00

Area 32 perches (809 square metres). Allotment 3 of section F.—(L.11-1020.)

Terms for Lot 5

A deposit of at least 12½% of the purchase price must be paid at the sale, either in cash or by cheque.

The residue is payable in eight half-yearly instalments or may be paid off at any earlier time.

Interest at the rate of 9% per annum is payable with all payments of residue, and is computed from the date of sale to the date of such payment. Additional interest is charged if the balance is not paid on or before the due date. If paid off in full within 30 days of sale, no interest is payable.

Lot 5

TOWNSHIP OF WONTHAGGI, PARISH OF WONTHAGGI

On the south side of Poplar Street, being No. 9 Poplar Street, Wonthaggi

Upset price \$800.00 the lot. Survey fee \$120.00

Area 35 perches (885 square metres). Allotment 11 of section 100.

NOTE.—Prospective purchasers of Lot 5 are advised that they will be liable for all charges levied by the respective authorities for the provision of road, footpath, kerb, channel sewerage and water supply to the land.—(G.74594.)

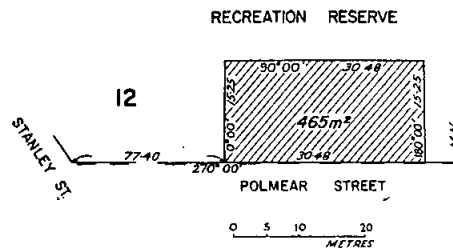

MARYBOROUGH.—The temporary reservation by Order in Council of the 16th December, 1907, of 1.950 hectares of land in the Parish of Maryborough (called municipal district of Maryborough in Order) as a site for Drainage purposes is about to be revoked, so far only as the portion containing 582 square metres, indicated by hatching on plan hereunder, is concerned.—(M.66(1*) (Rs.4502).

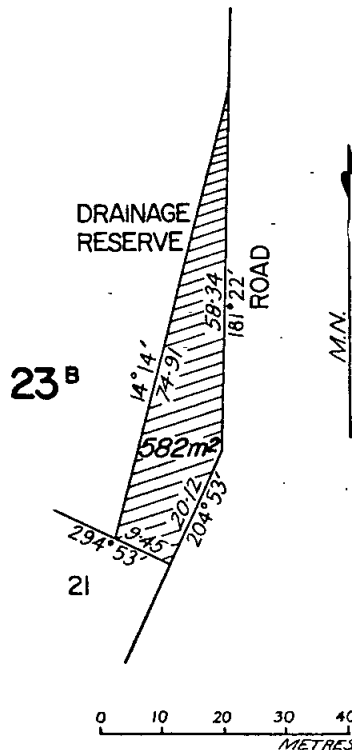

W. BORTHWICK,
Minister of Lands

PROPOSED REVOCATIONS OF TEMPORARY RESERVATIONS OF LANDS BY ORDERS IN COUNCIL

In pursuance of the provisions of the Land Act 1958, notice is hereby given that it is the intention of the Governor in Council to revoke the temporary reservations of lands by Orders in Council hereunder referred to viz.:—

The following Notices were published 1° on the 7th September, 1977, pursuant to Orders of the 30th August, 1977

TALLANGATTA VALLEY.—The temporary reservation by Order in Council of the 27th August, 1900, of 10.32 hectares of land in the Township of Tallangatta Valley (called Township of Wyeebo in Order) as a site for Public Recreation is about to be revoked so far only as the portion containing 465 square metres indicated by hatching on plan hereunder, is concerned.—(W.340(c.2) (Rs.4173).

PROPOSED REVOCATION OF TEMPORARY RESERVATIONS OF LAND BY ORDERS IN COUNCIL

In pursuance of the provisions of the Land Act 1958, notice is hereby given that it is the intention of the Governor in Council to revoke the temporary reservations of land by Orders in Council hereunder referred to, viz.:—

The following Notices were published 1° on the 14th September, 1977, pursuant to Orders of the 6th September, 1977.

MOOLAP (WALLINGTON).—The temporary reservation by Order in Council of the 18th May, 1976, of 3.391 hectares of land being Crown allotment 20r, Parish of Moolap as

a site for Public purposes (Park, Picnic and Historical purposes) is about to be revoked so far only as the portion containing 776 square metres indicated by hatching on plan hereunder, is concerned.—(M.226⁽⁵⁾) (Rs.10147).

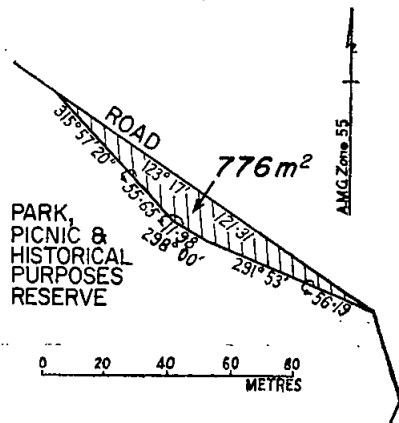

WALWA.—The temporary reservation by Order in Council of the 28th January, 1890, of 18.21 hectares of land adjoining Crown allotment 4, section 6, Parish of Walwa, as a site for Camping and Watering purposes, is about to be revoked.—(W.296⁽⁸⁾) (Rs.7920).

W. BORTHWICK,
Minister of Lands

PROPOSED REVOCATIONS OF TEMPORARY RESERVATIONS OF LANDS BY ORDERS IN COUNCIL

In pursuance of the provisions of the Land Act 1958, notice is hereby given that it is the intention of the Governor in Council to revoke the temporary reservations of lands by Orders in Council hereunder referred to viz.:—
The following Notices were published 1° on the 31st August, 1977, pursuant to Orders of the 23rd August, 1977

VIOLET TOWN.—The temporary reservation as a site for a Cemetery and the withholding from sale, leasing and licensing by Order in Council of the 18th August, 1879, of 7.861 hectares of land in the Township of Violet Town, revoked as to part by Order of the 14th November, 1945, are about to be revoked so far only as the portion containing .2699 square metres indicated by hatching on plan hereunder, is concerned.—(V.7⁽⁴⁾) (Rs.5374).

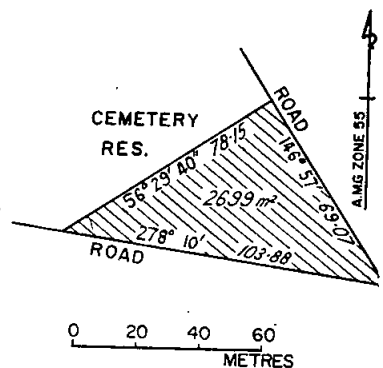

TUNGAMAH.—The temporary reservation as a site for the use of the Police Department and the withholding from sale leasing and licensing by Order in Council of the 6th November, 1882, of 8094 square metres of land in

the Township of Tungamah, revoked as to part by Order of the 25th June, 1946, are about to be revoked so far only as the portion containing 648 square metres indicated by hatching on plan hereunder, is concerned.—(T.218⁽⁴⁾) (Rs.5545).

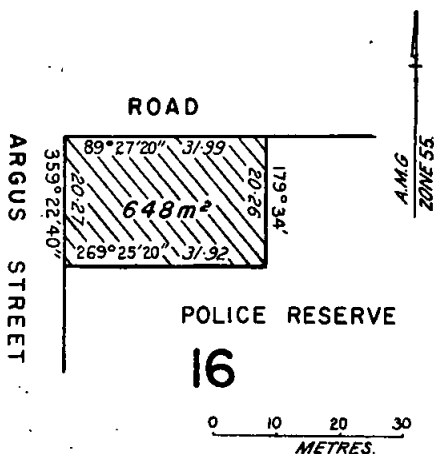

W. BORTHWICK,
Minister of Lands

PROPOSED PERMANENT RESERVATION OF LAND AS A SITE FOR PUBLIC PURPOSES (CONSERVATION OF WILDLIFE).

In pursuance of sections 14 and 21 of the Land Act 1958, notice is hereby given that it is the intention of the Governor in Council to reserve permanently from sale, from being leased and from having a licence granted in respect thereof the land hereinafter described:—

The following Notice was published 1° on the 14th September, 1977, pursuant to Order of the 6th September, 1977.

TINTALDRA.—Land proposed to be permanently reserved as a site for Public Purposes (Conservation of Wildlife) 7.2 hectares, more or less, being Crown allotment 10E, section 1A, Parish of Tintaldra, County of Benambra as indicated by hatching on plan hereunder.—(T.143⁽⁸⁾) (Rs.5519).

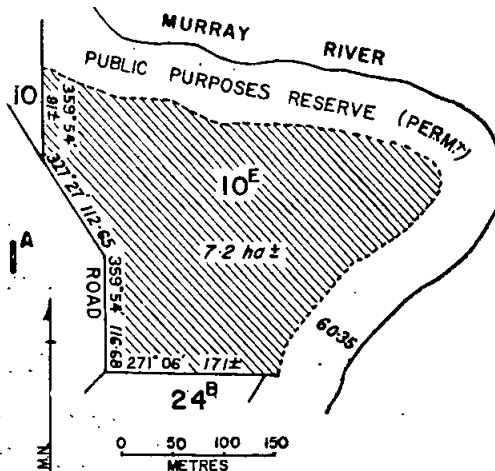

W. BORTHWICK,
Minister of Lands

PROPOSED REVOCATION OF TEMPORARY RESERVATION OF LAND BY ORDER IN COUNCIL

In pursuance of the provisions of the Land Act 1958, notice is hereby given that it is the intention of the Governor in Council to revoke the temporary reservation of land by Order in Council hereunder referred to, viz.:

The following Notice was published 1° on the 24th August, 1977, pursuant to an Order of the 16th August, 1977

TAMINICK.—The temporary reservation by Order in Council of the 6th July, 1965, of 67.58 hectares of land in the Parish of Taminick as a site for Public Purposes (Supply of Gravel) is about to be revoked, so far only as the portion containing 7552 square metres indicated by hatching on plan hereunder is concerned.—(T.155(2) (Rs.8497).

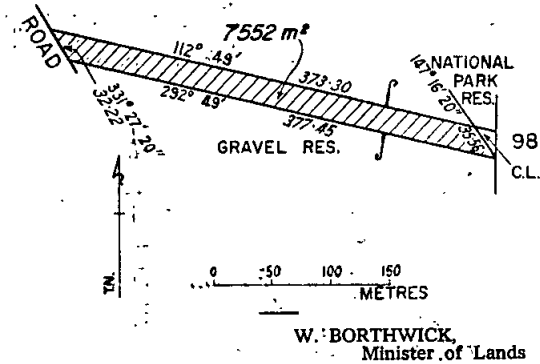

BVABEUBA

Teaching Service Act 1958

TEACHING SERVICE—PROFESSIONAL (CLASSIFICATION, SALARIES, AND ALLOWANCES) REGULATION

CORRIGENDUM

In Amendment No. 434 (PROF. C.S. & A.18) published on pages 2904 and 2905 of *Government Gazette* No. 75 dated 7th September, 1977, the following correction is made:—

In section 7 for the amount "\$15,684" substitute the amount "\$15,683"

W. E. SAMPSON, Chairman
A. F. LE CLERCQ, Secretary

Office of the Teachers Tribunal,
Melbourne, 12th September, 1977

Teaching Service Act 1958

TEACHING SERVICE—PRIMARY SCHOOLS DIVISION (CLASSIFICATION, SALARIES, AND ALLOWANCES) REGULATION

CORRIGENDA

In Amendment No. 435 (PRIM. C.S. & A.12) published on pages 2905 to 2907 of *Government Gazette* No. 75 dated 7th September, 1977, the following corrections are made:—

1. In section 10 for the figure "5,789" substitute the figure "5,189".

2. In section 14 for the figure "3,383" substitute the figure "9,383".

W. E. SAMPSON, Chairman
A. F. LE CLERCQ, Secretary

Office of the Teachers Tribunal,
Melbourne, 12th September, 1977

TENDERS**PUBLIC WORKS DEPARTMENT**

Tenders are invited for the purposes indicated hereunder and will be received at 2 Treasury Place, Melbourne, 3002, until **TWO** p.m. on dates shown.

Tenders must be addressed to the Minister of Public Works with the envelope endorsed "Tender for". Hand delivered tenders must be placed in the Department's tender box in the foyer, Ground Floor, 2 Treasury Place, Melbourne.

Tender documents are available from the Contracts Office, Room 27, 2 Treasury Place, Melbourne and, where indicated, at offices of Inspectors of Works.

Tuesday, 27th September, 1977

Building, Electrical and Mechanical Works

ASPENDALE.—Internal and external renovations, Primary School No. 4193.

AVONDALE.—Dental Therapy Unit (1 Chair), Primary School.

COBURG.—Demolition of "C" Division, Pentridge Prison.

COOLAROO SOUTH.—Dental Therapy Unit (2 Chairs), Primary School.

DEER PARK.—Dental Therapy Unit (1 Chair), Primary School.

DEER PARK.—Dental Therapy Unit (1 Chair), Primary School, Mechanical Services.

GLADSTONE PARK.—Dental Therapy Unit (1 Chair), Primary School.

GOWRIE PARK.—Dental Therapy Unit (1 Chair), Primary School.

GOWRIE PARK.—Dental Therapy Unit (1 Chair), Primary School, Mechanical Services.

KEILOR HEIGHTS.—Dental Therapy Unit (1 Chair), Primary School.

KEILOR HEIGHTS.—Dental Therapy Unit (1 Chair), Primary School, Mechanical Services.

LALOR NORTH.—Dental Therapy Unit (1 Chair), Primary School.

LALOR PARK.—Dental Therapy Unit (2 Chairs), Primary School.

LALOR PARK.—Dental Therapy Unit (2 Chairs), Primary School, Mechanical Services.

MOOMBA PARK.—Dental Therapy Unit (2 Chairs), Primary School.

MOOMBA PARK.—Dental Therapy Unit (2 Chairs), Primary School, Mechanical Services.

OLYMPIC VILLAGE.—Dental Therapy Unit (2 Chairs), Primary School.

OLYMPIC VILLAGE.—Dental Therapy Unit (2 Chairs), Primary School, Mechanical Services.

OVERPORT.—Internal and external repairs and painting, Primary School No. 4780. (Re-advertisement.)

PRESTON NORTH EAST.—Dental Therapy Unit (1 Chair), Primary School.

Site Works

HURSTBRIDGE.—Sealing of access road, High School.

TERANG.—Provision of Assembly Hall, site works, High School. (W.O., Geelong, Warrnambool.)

Miscellaneous

MELBOURNE.—Supply of contract draughting services for all engineering works in the department, period 1st October, 1977, to 31st March, 1978, State Public Offices.

MELBOURNE.—Maintenance cleaning—period 1st November, 1977 to 31st October, 1980, Public Offices, 436 Lonsdale Street.

PORT MELBOURNE.—Supply of (1) one only 12,000 lbs pneumatic tyred wheeled grader, Depot.

SUNBURY.—Maintenance cleaning for period 24th October, 1977 to 23rd October, 1980, Court House and Police Station.

No. 76—8910/77—3

Tuesday, 4th October, 1977

Building, Electrical and Mechanical Works

BENDIGO.—Improvement to fire service, High School, (W.O., Bendigo.)

CRANBOURNE.—Connection to sewer, Primary School No. 2068. (W.O., Dandenong.)

FAIRFIELD.—Renewal of water main, Fairlea Prison.

LEONGATHA.—Internal and external repairs and painting, High School. (W.O., Korumburra.)

LOCH.—External and internal repairs and painting, Primary School No. 2912. (W.O., Korumburra.)

SOLWAY.—External repairs and painting (cyclic), Primary School No. 4641.

YARRAGON.—Erection of new toilet block, Primary School No. 2178. (W.O., Warragul.)

ROBERTS DUNSTAN,
Minister of Public Works

Public Works Department,
Melbourne, 3002, 13th September, 1977

PRIVATE ADVERTISEMENTS**CITY OF BOX HILL**

LOAN No. 271

Notice of Intention to Borrow

Notice is hereby given that the Council of the City of Box Hill intends to borrow the sum of one hundred thousand dollars (\$100,000) secured by a charge over the General Rates of the Municipality by the grant of a mortgage in accordance with the provisions of the *Local Government Act 1958*.

In connection therewith the following information is stated:

1. The amount of principal moneys which it is proposed to borrow is One Hundred Thousand Dollars —\$100,000.
2. The maximum rate of interest that may be paid is 11 per centum per annum.
3. The purpose for which the loan is to be applied is Capital Works in the Council's Electricity Supply Undertaking.
4. The loan is to be liquidated over a period of 15 years by 30 half-yearly instalments of \$6,880.53 each covering principal and interest on the 31st day of October and the 30th day of April in each year during the currency of the loan, the first instalment shall be payable on the 30th April, 1978.
5. Such moneys shall be repayable to the Mutual Life and Citizens' Assurance Company Ltd., Collins Street and Elizabeth Street Melbourne.

The plans and specifications and the estimate of the cost of the proposed works and a statement showing the proposed expenditure of the moneys to be borrowed are open for inspection at the office of the Council of the City of Box Hill at the Town Hall, Box Hill.

353

I. G. PORT, Town Clerk

CITY OF BROADMEADOWS

LOAN No. 95

Notice of Intention to Borrow the Sum of \$90,000 for Permanent Works and Undertakings

Notice is hereby given that the Council of the City of Broadmeadows proposes to borrow the principal sum of \$90,000 secured by a charge over the general rates of the Municipality, such sum to be raised by the grant of a mortgage in accordance with the provisions of the *Local Government Act 1958*.

- (i) The maximum rate of interest that may be paid is 10 per centum per annum.
- (ii) The purposes for which the loan is to be applied are:—
 - (a) Broadmeadows By-Pass Road Construction \$80,000
 - (b) Mascoma Street Drainage Works/Storm-water Discharge from Essendon Airport \$10,000
- (iii) The period of the Loan shall be ten (10) years.

(iv) The moneys borrowed shall be repayable by providing out of the Municipal Fund half-yearly instalments of approximately \$7,120.60 each including principal and interest on the first day of November and the first day of May during the currency of the Loan.

The first instalment shall be payable on the first day of May 1978.

(v) Such moneys shall be repayable to the Australia and New Zealand Banking Group Limited at the Offices of the said Bank, 351 Collins Street, Melbourne, or such other place or places as directed.

The plans and specifications and the estimate of the cost of the proposed works and a statement showing the proposed expenditure of the moneys to be borrowed are open for inspection at the Municipal Offices, Pascoe Vale Road, Broadmeadows.

267 W. HOLMES, Acting Town Clerk

CITY OF CROYDON

LOAN No. 147

Notice of Intention to Borrow the Sum of \$50,000 for Permanent Works and Undertakings

Notice is hereby given that the Council of the City of Croydon proposes to borrow the principal sum of Fifty Thousand Dollars (\$50,000) secured by a charge over the general rates of the municipality, such sum to be raised by the grant of a mortgage in accordance with the provisions of the Local Government Act 1958.

1. The maximum rate of interest that may be paid is 11 per centum per annum.

2. The purpose for which the loan is to be applied is:

Purchase of Public Open Space being Part Lot 2, LP 16643 Taylors Road (Part) \$50,000

3. The period of the loan shall be 15 years.

4. The moneys borrowed shall be repayable by thirty half-yearly instalments of approximately \$3,440.27 including principal and interest on the 12th day of December and the 12th day of June, during the currency of the loan. The first instalment shall be repayable on the 12th day of June, 1978.

5. Such moneys shall be repayable at the Commercial Savings Bank of Australia Ltd., 335 Collins Street, Melbourne.

The plans and specifications and the estimate of the cost of the proposed works and a statement showing the proposed expenditure of the moneys to be borrowed are open for inspection at the Office of the Council of the City of Croydon at the City Offices, Foch Avenue, Croydon.

268 R. BURTON, Town Clerk

CITY OF DONCASTER AND TEMPLESTOWE

Pursuant to the provisions of section 522 of the Local Government Act 1958, the Council of the City of Doncaster and Templestowe hereby directs that the land being part of Lot 2 on Plan of Subdivision 66530 shown hatched on the plan annexed hereto which has been purchased, taken or acquired by it shall be a Public Highway on and from the date of publication of this Order in the Government Gazette.

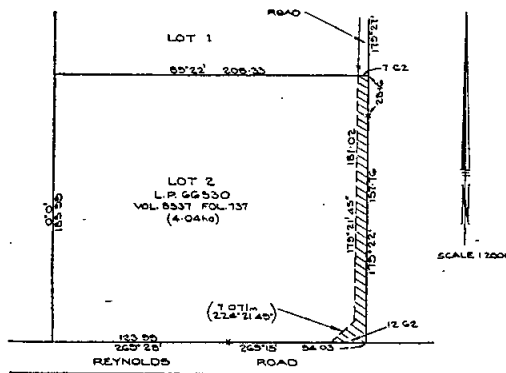

Dated this 6th day of September, 1977

The common seal of the Mayor, Councillors and Citizens of the City of Doncaster and Templestowe was hereto affixed, in the presence of—

(SEAL) J. C. SCOTT, Councillor
K. J. GRAY, Councillor
J. W. THOMSON, Town Clerk

CITY OF DONCASTER AND TEMPLESTOWE

LOAN No. 213

Notice of Intention to Borrow

Notice is hereby given that the Council of the City of Doncaster and Templestowe intends to borrow Fifty thousand dollars (\$50,000.00) secured by a charge over the General rates of the municipality by the grant of a Mortgage in accordance with the provisions of the Local Government Acts.

In connection therewith the following information is stated:—

(a) The amount of the principal moneys which it is proposed to borrow is Fifty thousand dollars (\$50,000).

(b) The maximum rate of interest that may be paid is 10.9 per centum per annum.

(c) The times which the moneys borrowed are to be repayable are the Fifteenth day of May and the Fifteenth day of November during the Years 1978-1987 inclusive and that the place such moneys shall be repayable is at the Bank of New South Wales, Doncaster East.

(d) The purpose for which the loan is to be applied is:

Part cost of alterations and extensions to Municipal Offices, Doncaster Road, Doncaster —\$50,000.00.

(e) The manner in which the Loan is to be liquidated is by provision out of the Municipal Fund in each half-year during the currency of the Loan of the sum of \$4,166.63 which includes Principal and Interest.

The plans and specifications and estimate of the cost of the works and a statement showing the proposed expenditure of the moneys to be borrowed are open for inspection at the Municipal Offices, Doncaster Road, Doncaster.

Dated this 12th day of September, 1977

269 J. W. THOMSON, Town Clerk

CITY OF ESSENDON

LOAN No. 111

Notice of Intention to Borrow the Sum of \$198,000 for Permanent Works and Undertakings

Notice is hereby given that the Council of the City of Essendon proposes to borrow the principal sum of \$198,000 (one hundred and ninety eight thousand dollars) secured by a charge over the general rates of the municipality, such sum to be raised by the grant of a mortgage in accordance with the provisions of the Local Government Act 1958 (as amended).

1. The maximum rate of interest that may be paid is 11 per centum per annum.

2. The purpose for which the loan is to be applied is as follows:—

For and towards the cost of construction of:

Ascot Vale Leisure Centre	\$100,000
Maribyrnong Park Tennis Club House	46,000
Fisher Parade Bridge	52,000

3. The period of the loan shall be fifteen (15) years.

4. The moneys borrowed shall be repayable by providing out of the municipal fund half yearly instalments of approximately \$13,623.47 each, including principal and interest, on the 10th day of April and October of each year during the currency of the loan. The first instalment shall be payable on the 10th April, 1978.

5. Such moneys shall be repayable at the office of the Commonwealth Savings Bank of Australia, Head Office, Melbourne, or at such other places as the lender may direct.

The plans and specifications of the proposed works and a statement showing the proposed expenditure of the moneys to be borrowed are open for inspection at the office of the Council of the City of Essendon, State of Victoria, at the Civic Centre, Moonee Ponds.

270 J. P. SCOTT, Town Clerk

CITY OF NUNAWADING

Notice is hereby given that in pursuance of the powers conferred by the Local Government Act the Council of the City of Nunawading did at a meeting held on the 1st August 1977 order that the following alteration be made to the name of that street abutting the east boundary of Lot 26 and the west boundary of Lot 25 on L.P.19083 as under—

Old Name—Park Close.

New Name—Willis Court.

352

E. J. JANE, Town Clerk

BOROUGH OF WONTHAGGI

LOAN No. 46

*Notice of Intention to Borrow \$14,000 for
Permanent Works and Undertakings*

Notice is hereby given that the Council of the Borough of Wonthaggi proposes to borrow the principal sum of fourteen thousand dollars secured by a charge over the general rates of the municipality, such sum to be raised by the grant of a mortgage in accordance with the provisions of the Local Government Act 1958.

1. The maximum rate of interest that may be paid is 10.9 per cent. per annum.
2. The purpose of the loan is to meet the cost of:—
Kerb, channel and underground drains in McKenzie Street, Wonthaggi \$14,000
3. The period of the loan shall be 10 years.
4. The moneys borrowed shall be repayable by providing out of the municipal fund 20 half yearly instalments of \$1,166.66 including principal and interest on the 31st day of April and the 31st day of October during the currency of the loan. The first instalment shall be payable on the 31st April, 1978.
5. Such moneys shall be repayable at the National Bank of Australasia Ltd. at 64 McBride Avenue, Wonthaggi.

The plans and specifications together with the estimate of costs of the proposed works and a statement showing the proposed expenditure of the moneys to be borrowed are open for inspection at the office of the Council of the Borough of Wonthaggi.

278

A. A. N. DEED, Town Clerk

SHIRE OF COBRAM

NOTICE OF INTENTION TO TAKE LAND COMPULSORILY

Notice is hereby given that:—

(1) The Council of the Shire of Cobram desires to increase the area of Queen Street Gardens at the south-western corner of High and Queen Streets, Cobram.

(2) For the purpose of executing such work Council deems it expedient to exercise its power of taking compulsorily the portion of land being Lot 55 Queen Street on Plan of Subdivision 1834, Parish of Cobram, County of Moira.

(3) The Council has caused to be prepared, maps and other papers describing the proposed work or undertaking and the land proposed to be taken together with the names of every owner or reputed owner, every lessee or every reputed lessee, every mortgage and the occupier thereof as far as such names can be ascertained by the Council.

(4) Such maps and other papers are deposited at the Shire Office, Cobram, where they are and will remain open for inspection by all persons interested at all reasonable hours for the space of 40 clear days after publication of this notice in the *Government Gazette*.

(5) All persons affected by the proposed work or undertaking are hereby called upon to set forth in writing addressed to the Council or Shire Secretary of the Shire of Cobram within 40 clear days from the publication of this notice in the *Government Gazette*, all objections which they may have to the said work or undertaking.

Dated this 5th day of September, 1977

309

By order of the Council,
R. T. CUTTS, Shire Secretary

SHIRE OF COBRAM

BY-LAW No. 28

Notice is hereby given in accordance with Section 207 (a) (ii) of the Local Government Act 1958 as amended that the Council of the Shire of Cobram has made a By-Law No. 28 for the purpose of prohibiting or regulating the escape of water used for the purpose of irrigation or otherwise on to any public road or highway. A copy of the By-Law is open for inspection free of charge during office hours at the Office of the Council at 44 Station Street,

Dated this 14th day of September, 1977

308

R. T. CUTTS, Shire Secretary

Town and Country Planning Act 1961 (Twelfth Schedule)

SHIRE OF COBRAM—COBRAM PLANNING SCHEME 1949

NOTICE THAT A PLANNING SCHEME HAS BEEN PREPARED AND IS AVAILABLE FOR INSPECTION

Amendment No. 13

Notice is hereby given that the Shire of Cobram in pursuance of its powers under the Town and Country Planning Act 1961 has prepared a Planning Scheme for the area of the Cobram Planning Scheme 1949 for the purpose of re-modelling the Cobram Planning Scheme 1949 to comply with modern planning concepts.

A copy of the Scheme has been deposited at the Office of the Town and Country Planning Board, 235 Queen Street, Melbourne and the Shire Office, 44 Station Street, Cobram and will be open for inspection during office hours by any person free of charge.

Any persons affected by the Planning Scheme are required to set forth in writing all objections they may have, addressed to the Shire Secretary, Shire of Cobram, 44 Station Street, Cobram, 3644 on or before the 14th day of December, 1977, and to state whether they wish to be heard in respect of their objections.

Dated 14th September, 1977

307

R. T. CUTTS, Shire Secretary

SHIRE OF CORIO

LOAN No. 115

*Notice of Intention to Borrow the Sum of \$75,000 for
Permanent Works and Undertakings*

Notice is hereby given that the Council of the Shire of Corio proposes to borrow the principal sum of \$75,000 secured by a charge over the general rates of the municipality, such sum to be raised by the grant of a mortgage in accordance with the provisions of the Local Government Act 1958.

1. The maximum rate of interest that may be paid is 10.9 per cent per annum.
2. The purpose for which the loan is to be applied is:
Community facilities at Geelong Trotting, Sporting and Recreation Complex.
3. The period of the loan shall be ten years.
4. The monies borrowed shall be repayable by providing out of the municipal fund half-yearly instalments of approximately \$6,249.94 each including principal and interest on the 20th day of October and the 20th day of April during the currency of the loan. The first instalment shall be payable on the 20th day of April 1978.
5. Such monies shall be repayable to the Bank of New South Wales Savings Bank at the office of the said Bank, Melbourne Road, North Geelong.

The plans and specifications and the estimate of the cost of the proposed works and a statement showing the proposed expenditure of the monies to be borrowed are open for inspection at the office of the Council of the Shire of Corio at Osborne House, North Geelong.

Dated 12th September, 1977.

310

R. P. METCALF, Shire Secretary

SHIRE OF KORUMBURRA

ROAD DEVIATION ORDER

Pursuant to the provisions of section 522 of the Local Government Act the Council of the Shire of Korumburra hereby directs that the land in the Parish of Kongwak and the Parish of Jumbunna East indicated by hatching on the

diagrams hereunder which have been purchased, acquired, or taken by it shall be a Public Highway on and from the date of publication of this Order in the Government Gazette:

PLAN FOR TRANSFER PURPOSES

CROWN ALLOTMENT 3B
PARISH OF KONGWAK
COUNTY OF MORNINGTON

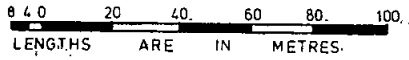

SHIRE OF KORUMBURRA — STEWARTS ROAD

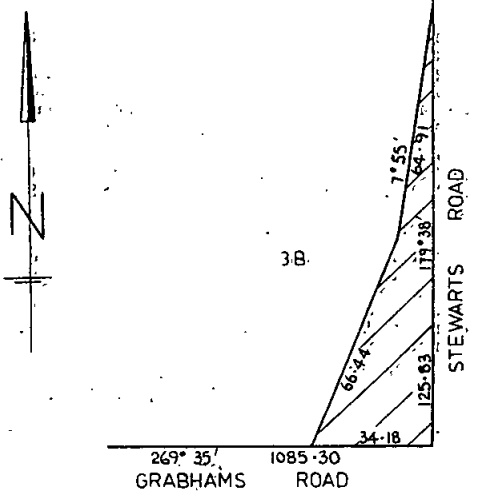

PLAN FOR TRANSFER PURPOSES

CROWN ALLOTMENT 58E
PARISH OF JUMBUNNA EAST
COUNTY OF MORNINGTON

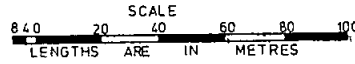

SHIRE OF KORUMBURRA — STEWARTS ROAD

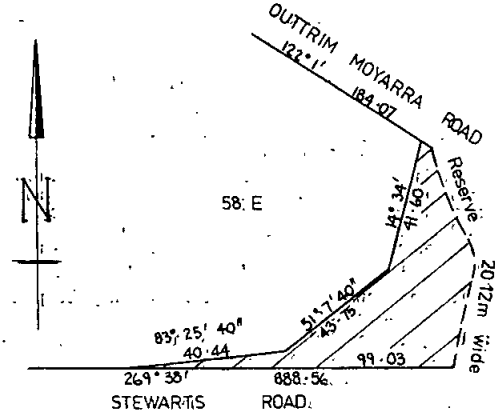

PLAN FOR TRANSFER PURPOSES

PART OF CROWN ALLOTMENT 24A
PARISH OF KONGWAK
COUNTY OF MORNINGTON

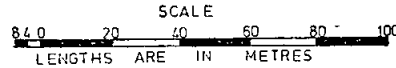

SHIRE OF KORUMBURRA — STEWARTS ROAD

PLAN FOR TRANSFER PURPOSES
PART OF CROWN ALLOTMENT 24A
PARISH OF KONGWAK
COUNTY OF MORNINGTON

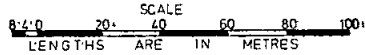

SHIRE OF KORUMBURRA — STEWARTS ROAD

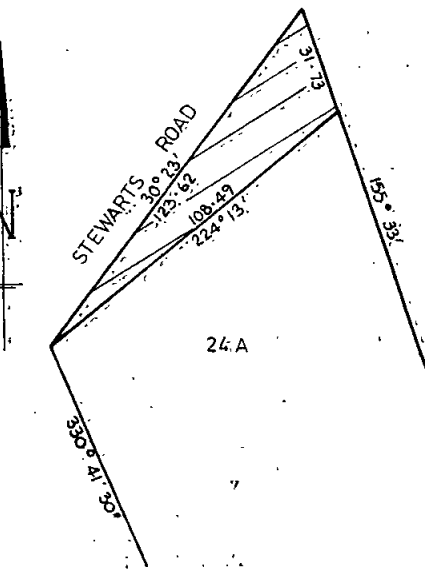
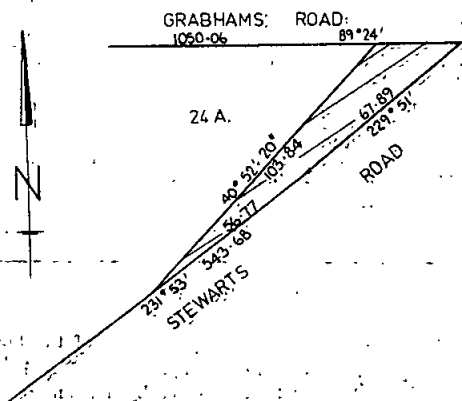

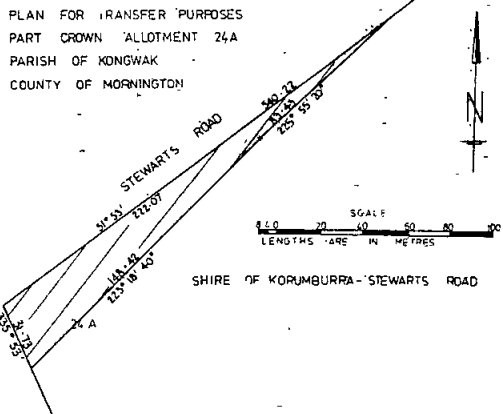
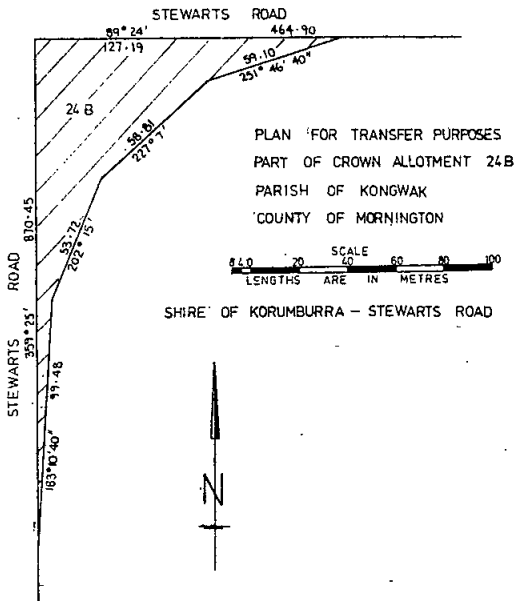

The common seal of the President, Councillors and Ratepayers of the Shire of Korumburra was hereunto affixed, this 17th day of August, 1977, in the presence of—

355

(SEAL)

R. W. BROWN, Shire President
J. W. LITTLE, Councillor
W. O. CLARK, Shire Secretary

SHIRE OF MARONG

LOAN No. 35

Notice of Intention to Borrow the Sum of \$42,000 for Permanent Works and Undertakings

Notice is hereby given that the Council of the Shire of Marong intends to borrow \$42,000 secured by a charge over the general rates of the Municipality by the grant of a mortgage in accordance with the provisions of the Local Government Act 1958.

1. The maximum rate of interest that may be paid is 10.9 per cent per annum.
2. The purpose for which the loan is to be applied is construction of underground drainage kerbing and channelling and associated road works.
3. The money borrowed shall be repaid by 20 half yearly instalments of \$3,499.97 each, including principal and interest, on the 3rd day of May and the 3rd day of November in each year during the currency of the loan. The first instalment shall be payable on 3rd May, 1978.

4. Such amounts will be payable at the Australian and New Zealand Savings Bank Ltd., Pall Mall, Bendigo.

The plans and specifications and estimate of the cost of the works and a statement showing the proposed expenditure of the money to be borrowed are open for inspection at the Shire Office, Marong.

273

GRAEME ELVEY, Shire Secretary

SHIRE OF ORBOST

By-Law No. 67

Notice is hereby given in accordance with Section 207 (a) (ii) of the Local Government Act 1958, as amended, that the Council of the Shire of Orbost has made a By-Law No. 67 for the purpose of regulating or prohibiting the placing and use of caravans on private property within the Shire of Orbost. A copy of this By-Law is open for inspection free of charge during office hours at the office of the Council, Ruskin Street, Orbost, 3888.

Dated this 2nd day of September, 1977

274

R. E. VERNON, Shire Secretary

SHIRE OF SHERBROOKE

LOAN No. 153

Notice of Intention to Borrow the Sum of \$220,000 for Permanent Works and Undertakings

Notice is hereby given that the Council of the Shire of Sherbrooke intends to borrow the principal sum of \$220,000 from the Australia & New Zealand Bank Ltd., secured by a charge over the general rates of the municipality, such sum to be raised by the grant of a mortgage in accordance with the provisions of the Local Government Act 1958.

1. The maximum rate of interest that may be paid is 11.0 per centum per annum.
2. The purposes for which the loan is to be applied are—
(i) Belgrave Swimming Pool Construction.
(ii) Country Roads Board Works—Council Share.
(iii) Land Acquisition and Tip Extensions costs—Lysterfield.
3. The period of the loan shall be fifteen (15) years.
4. The moneys borrowed shall be repayable by providing out of the municipal fund twenty half yearly instalments of approximately \$15,137.19, repayable on the first day of May and the first day of November in each year. The first instalment shall be payable on 1st May 1978.
5. Such moneys shall be repayable at the office of the Australia & New Zealand Bank Ltd., 394-396 Collins Street, Melbourne.

The plans and specifications and estimate of the cost of the proposed works and undertakings are open for inspection at the office of the Shire of Sherbrooke, Glenfern Road, Upwey.

275

K. E. MATSON, General Manager

SHIRE OF STAWELL WATERWORKS TRUST

NOTICE TO THE OWNERS OF TENEMENTS IN SILVER SPRINGS EAST ROAD, HALLS GAP EASTERLY FROM AND INCLUDING LOT 12 L.P.56322

The main pipe in the said street having been laid down the owners of all tenements situated as above are hereby required on or before the 21st day of September next to cause a proper pipe and stop cocks to be laid so as to supply water within such tenements from the main pipe.

V. C. NIELSEN, Secretary of Shire of Stawell Waterworks Trust 276

SHIRE OF STRATHFIELDSAYE

DEDICATION TO THE PUBLIC AS A PUBLIC HIGHWAY OF A STREET CONSTRUCTED TO THE SATISFACTION OF THE COUNCIL

Whereas the private streets known as

- (a) Plante Court
- (b) Hillary Court
- (c) Tenzing Court
- (d) Sherpa Court

being more than 15 feet in width, having been constructed to the satisfaction of the Council but not constructed pursuant to Division 10 of Part XIX, or Part XLII, of the Local Government Acts or any corresponding previous enactment:

And whereas the owners of so many of the premises fronting on such street as in rateable value are the greater part of all the premises so fronting, having made application to the Council to have such street declared to be dedicated to the public as a public highway:

Now therefore the Council of the Shire of Strathfieldsaye, in pursuance of the provisions of section 587 (3) of the *Local Government Act 1958*, hereby declares that

- (a) Plante Court
- (b) Hillary Court
- (c) Tenzing Court
- (d) Sherpa Court

shall be dedicated to the public as a public highway.

The common seal of the President, Councillors and Ratepayers of the Shire of Strathfieldsaye was hereunto affixed this 1st day of September, 1977, in pursuance of a Resolution of the Council, and in the presence of—

(SEAL) J. A. COLVIN, President
R. W. SOMERVILLE, Councillor
M. BRENNAN, Secretary

Council Chambers, Condon Street, Kennington, 3550
279

Town and Country Planning Act 1961
SHIRE OF VIOLET TOWN INTERIM DEVELOPMENT
ORDER

AMENDMENT No. 2, 1977

Notice is hereby given that the Shire of Violet Town has prepared Amendment No. 2, 1977, of the above Interim Development Order for the purpose of increasing the minimum area of an allotment that may be created under the Rural Zone and Rural Highway Zone from 24 hectares or its acreage equivalent, to 60 hectares or its acreage equivalent.

A copy of the amendment has been deposited at the Shire Office, Lily Street, Violet Town and at the office of the Town and Country Planning Board, 235 Queen Street, Melbourne.

All persons affected by the amendment are called upon to set forth in writing addressed to the undersigned within one month from the date of publication of this notice in the *Government Gazette* all objections which they may have to the amendment and stating whether they wish to be heard in respect of their objection.

277 JOHN G. KERR, Shire Secretary

Town and Country Planning Act 1961
WARATAH BAY PLANNING SCHEME

NOTICE THAT A PLANNING SCHEME HAS BEEN PREPARED
AND IS AVAILABLE FOR INSPECTION

Amendment No. 12, 1977

Notice is hereby given that the Shire of South Gippsland, in pursuance of its powers under the *Town and Country Planning Act 1961*, has prepared a Planning Scheme for—

Part C.A. 21A, Parish of Waratah North
for the purpose of re-zoning the above land from Rural to Rural Village.

A copy of the scheme has been deposited at the Shire Office, 14-18 Pioneer Street, Foster, and at the office of the Town and Country Planning Board, 235 Queen Street, Melbourne, and will be open for inspection during office hours by any person free of charge.

Any persons affected by the Planning Scheme are required to set forth in writing all objections they may have, addressed to the Shire Secretary, P.O. Box 104, Foster 3960, on or before the 14th day of October, 1977, and to state whether they wish to be heard in respect of their objections.

7th September, 1977

313 H. R. LOMAX, Shire Secretary

SHIRE OF WOORAYL

NOTICE OF CHANGE OF STREET NAME

Notice is hereby given that in pursuance of the powers conferred by the *Local Government Act 1958*, the Council of the Shire of Woorayl has ordered that the names of the following streets be changed, as set out hereunder:—

Beach Way, Inverloch to Bear Street.
Gray Street, Venus Bay to Hakea Street.
Jeffrey Street, Venus Bay to Jasmine Street.
Kathryn Street, Inverloch to Katrina Street.
Koonwarra Avenue, Promontory Views to Grevillia Street.

Michael Avenue, Venus Bay to Merkani Avenue.
Outlook Drive, Promontory Views to Melaleuca Avenue.
Venus Bay Drive, Inverloch to Veronica Street.
View Street, Leongatha to Vista Court.
Wilson Avenue, Venus Bay to Woorak Avenue.
Fish Creek-Walkerville Road, Promontory Views to Acacia Road.
Main Street, Tarwin Lower to River Drive.
Tarwin Lower-Walkerville Road, Tarwin Lower to Walkerville Road.
Government Road, Koonwarra to Kookaburra Drive.
Inverloch Road, Koonwarra to Koala Drive.
Government Road, Inverloch to Goroke Street.
Foreshore Road, Walkerville to Bayside Drive.
Government Road, Walkerville to Casuarina Grove.

314 R. G. STANLEY, Shire Secretary

In the Supreme Court of Victoria—M. No. 12263—In the matter of WILLIAM COUSINS; and in the matter of an application by the Honourable the Attorney-General of the State of Victoria, pursuant to section 33 (1) of the *Supreme Court Act 1958*

BEFORE HIS HONOUR MR. JUSTICE STARKE,
MONDAY THE 5TH DAY OF SEPTEMBER, 1977

Upon motion made on the 21st, 22nd and 23rd days of March 1977 and this day on behalf of the Honourable the Attorney-General pursuant to a Notice of Motion dated the 7th day of March 1977 and filed herein and upon reading the said Notice of Motion, the Affidavit of Joan Carmel Kapphan sworn the 28th day of July 1975 filed in action numbered 3077 of 1975 and the exhibits thereto, the Affidavit of Michael Anthony Flemming sworn the 7th day of March 1977, the Affidavit of Percival Stanley Malbon sworn the 7th day of March 1977, the Affidavit of John Henry Wilkinson sworn the 7th day of March 1977 and the exhibits thereto, the Affidavit of Alan Francis Spencer sworn the 7th day of March 1977 and the exhibits thereto, the Affidavit of James Stanislaus Mornane sworn the 7th day of March 1977 and the exhibit thereto, the Affidavit of Richard David Szentel sworn the 7th day of March 1977, the Affidavit of James Stanislaus Mornane sworn the 9th day of March 1977, the Affidavit of Adrian Oscar Castellias sworn the 2nd day of September 1977 and the exhibit thereto, the Affidavit of James Stanislaus Mornane sworn the 5th day of September 1977 and the exhibit thereto, the Affidavit of John Anthony Hefferman sworn the 5th day of September 1977 and the exhibit thereto and the Affidavit of James Stanislaus Mornane sworn the 5th day of September 1977 all filed herein and upon hearing Mr. Uren of Counsel for the Honourable the Attorney-General there being no appearance by or on behalf of William Cousins this Court doth order pursuant to Section 33 (1) of the *Supreme Court Act 1958* that no legal proceedings shall without the leave of the Court be instituted by the said William Cousins in any Court and this Court doth further order that any legal proceedings instituted by the said William Cousins in any Court before the making of this Order shall not be continued by him without such leave and this Court doth further order that the Attorney-General's costs of this application including reserved costs be taxed and when taxed be paid by the said William Cousins.

By the Court,

This order was taken out by E. L. Lane, Crown Solicitor, of 221 Queen Street, Melbourne, and Solicitor for the Honourable the Attorney-General of the State of Victoria.

287

REGULATIONS FOR THE CARE, PROTECTION AND
MANAGEMENT OF "RICHMOND PARK", IN THE
CITY OF RICHMOND

Whereas by section 219 of the *Land Act 1958*, it is enacted that where, under the provisions of any Act relating to Crown lands, the Governor in Council, either before or after the commencement of such Act, has reserved from sale permanently any Crown lands for any public purposes whatsoever, or for any of the purposes specified in section 14 of such Act or the corresponding section of any repealed Act, and has vested such land in trustees, it shall be lawful for the trustees of any such land, with the approval of the Governor in Council, to make Rules and Regulations for all or any of the purposes mentioned in sub-section (1) of section 219, *Land Act 1958*: And whereas a Crown Grant has issued in favour of the Board of Land and Works and the Mayor, Councillors and Citizens of the City of Richmond in respect of land in the said City permanently reserved as a site for Public Park and Recreation by Order in Council dated the 13th October,

1873 (vide *Government Gazette* of the 14th November, 1873) and known as "Richmond Park": And whereas areas have been excised from time to time from the said reserved land: And whereas it is expedient that Regulations for the remaining portions of the said land (hereinafter referred to as the "Reserve") be now made: And whereas the said Board of Land and Works was dissolved by the *Public Lands and Works Act 1964* which provided, *inter alia*, that all lands vested pursuant to the *Land Act 1958* in the Board and Trustees shall be deemed to be vested in the Minister of Lands and the same trustees for the same purposes and subject to the same conditions: Now therefore, in view of the powers conferred as aforesaid and every other power so enabling, the Minister of Lands and the Mayor, Councillors and Burgesses of the City of Richmond (hereinafter referred to as the "Council") do hereby make the following Regulations in respect of the Reserve in lieu of all previous Regulations relating thereto which are hereby rescinded:—

REGULATIONS

1. No person other than a member of the Council or an officer or employee of the Council on duty shall enter the Reserve when a charge or entrance fee is made for admission thereto as hereinafter provided without first paying such charge unless such person is excused by the Council in writing from paying such charge or entrance fee.
2. The Reserve shall be open to the public from sunrise to sunset free of charge except on such days and at such hours as the Council may by resolution set aside as days on which charges or entrance fees may be received and collected from any person entering in or upon the Reserve or any specified part or parts thereof, and on any of such days such charges or entrance fees which the Council may by resolution specify may be so received and collected.
3. The Council may grant permission in writing to any person, club, organization or group of persons to use the Reserve provided such use accords with the purposes of the reservation.
4. No person shall interfere with or break or damage or remove any tree, plant, shrub or flower in or upon the Reserve or walk on the flower beds or borders, or climb jump or get upon or over any fence, gate or building or part thereof or post bills or advertisements on any of the fences, gates, walls, seats or other structures in the Reserve, or roll or throw stones or missiles, or leave in the Reserve or in any part thereof or in any building therein any bottle, can, broken glass, paper, fruit skins or peel or any refuse or rubbish whatsoever except in the receptacles provided, or spit or expectorate upon or otherwise foul any path or structure, or remove, displace, disfigure or damage any noticeboard, scoreboard or other erection in or upon the Reserve.
5. No person shall carry firearms in or through the Reserve or shoot, snare or destroy or attempt to shoot, snare or destroy any bird or animal therein or thereon except by the written authority of the Council.
6. No person, club, organization or group of persons shall engage in, play or practice cricket, football, bowls, tennis, lacrosse, golf or any like games in or upon the Reserve without written authority of the Council and then only on payment of such sum or sums as may be set out by resolution of the Council; provided, however, that the provisions of this Regulation shall not be applicable to children under the age of fourteen years when occupied in playing ball games on areas displaying a notice erected by the Council announcing that ball games or other games are permitted to be played on such areas.
7. No person shall play any unlawful game or make any wager for money or carry on any form of gambling in the Reserve without the written authority of the Council and all other relevant authorities, or engage in any unseemly, disorderly or indecent conduct or otherwise interfere with the comfort or enjoyment of any other person or persons within the Reserve.
8. No person shall interfere with or in any way hinder or interrupt any employee of the Council or person authorized by the Council engaged in any duty in the Reserve.
9. No person shall sell, expose or offer for sale within the Reserve any article whatever or operate or cause to be operated any amusement for which a charge is made or make a collection of money for any purpose without the written authority of the Council.
10. No person shall behave in a disorderly manner or create or take part in any fight or disturbance or use any indecent or abusive language or commit any nuisance or in any way offend against decency by means of dress, language or conduct in the Reserve and no person shall enter or remain in the Reserve whilst in a drunken or intoxicated condition or whilst under the influence of drugs.
11. No person other than a player, official or competitor at any sports match or sports gathering duly authorized in accordance with the provisions of these Regulations shall enter or remain within or upon any playing arena in the Reserve during the progress of such sports match or sports gathering or otherwise interfere with the same or interrupt or interfere with any employee of the Council or person authorized by the Council in the proper execution of his duty or work.
12. No person shall remain in the Reserve at any time when lawfully directed to leave the same by any police officer or officer or employee of the Council or person authorized by the Council notwithstanding that a fee or charge for admission may have been paid.
13. No person other than an officer or employee of the Council or person authorized by the Council shall enter any plots or areas which are set aside for the planting or growing of flowers, trees or shrubs in the Reserve.
14. No person other than an officer or servant of the Council shall ride or drive any horse, motor car, motor cycle or other vehicle or any bicycle into or upon the Reserve except for the purpose of parking such motor car, motor cycle, bicycle or other vehicle in any parking area set aside for that purpose by the Council, provided that this Regulation shall not apply to the wheeling of bicycles, prams, invalid wheelchairs, child or baby carriages and children's toys along any delineated footpath in the Reserve.
15. No person shall permit or suffer any animal owned by him or of which he is in charge to be in or upon the Reserve unless such animal be controlled by a leash, chain or other restraining device.
16. In any portion of the Reserve where a children's playground has been established by the provision of playground equipment such as swings or by notice that such portion is a children's playground:—
 - (i) No person above the age of fourteen years shall enter upon or remain on such an area or use any of the swings or other playground equipment therein; provided, however, that parents or other persons in charge of children shall not be prohibited from entering upon or remaining on the area or from using any seating which may be provided to watch over or supervise children in their charge.
 - (ii) No person shall use any swing or other playground equipment erected in such an area for a longer period than five minutes if any other person is waiting to use such appliance.
 - (iii) No person shall enter or remain in a children's playground after the hour of sunset and before the hour of sunrise unless authorized by the Council.
17. Every person being on the Reserve shall obey the directions of any police officer, officer of the Council or person authorized by the Council in respect of his or her conduct therein.
18. No person whilst in or upon the Reserve shall fly or permit to be flown any model aeroplane over such Reserve.
19. No person shall camp or pitch, erect or occupy any camp, tent or temporary shelter in or upon the Reserve nor remove therefrom any earth, sand, stone, marl or gravel without the written consent of the Council.
20. No person shall without the written consent of the Council and the observance of all statutory restrictions which may be in force light any fire or permit any fire to remain alight in the Reserve except in a fire-place or barbeque provided by the Council.
21. No person without the written permission of the Council and a permit to sell or supply liquor issued pursuant to the *Liquor Control Act* shall supply or sell any alcoholic liquor to any person or persons in the Reserve.
22. No person without the written permission of the Council shall consume alcoholic liquor within any pavilion, structure, tent or temporary building in the Reserve.
23. No person shall damage or cause to be damaged any pavilion, structure, tent or temporary building erected in the Reserve. (Rs. 152.)

Given under my hand at Melbourne on the twenty-eighth day of June, 1977

JIM BALFOUR, Minister of Lands

Every person who contravenes or fails to comply with these Regulations shall, in accordance with the provisions of section 219 of the *Land Act 1958*, for each

offence be liable to a penalty of not more than fifty dollars (\$50) and every person who contravenes or fails to comply with any such Regulations, and who, after he has been warned by any bailiff of Crown Lands or by any member of the Police Force, does not desist therefrom may be forthwith apprehended by such bailiff or member of the Police Force and taken before some justice to be dealt with according to law and shall be liable to a penalty of not more than One hundred dollars (\$100); provided that every person who contravenes any regulation made under the said section for or with respect to prohibiting the depositing and leaving of any unwanted material or thing or rubbish of any kind on any land to which this section relates shall for each offence be liable to a penalty of not more than two hundred dollars (\$200). 295

Notice is hereby given that F. A. MAKER PTY. LTD. has applied for a lease pursuant to section 135 (7) of the Land Act 1958 for a term of 10 years in respect of Allotment 5 Section B Parish of Melbourne South containing 1,245 square metres as a site for commercial and industrial purposes. 243

S. C. KUPSCH, Secretary

Notice is hereby given that Australian Motor Industries Limited has applied for a lease pursuant to section 134 of the Land Act 1958 for a term of 20 years in respect of Allotment 68 section 63A Parish of Melbourne South and containing 1.0117 hectares as a site for General Industrial Purposes. 285

Take notice that Giuseppa Xalfa of 48 Harrison Street, Brunswick in the State of Victoria on behalf of her infant daughter Patricia Elvira Xalfa formerly called Patricia Elvira Quirino did by Deed Poll dated the 8th day of September 1977 on behalf of Patricia Elvira Quirino change her name to Patricia Elvira Xalfa. 347

NOTICE OF INTENTION TO APPLY FOR A LICENCE TO DIVERT WATER AND CUT RACE FROM THE BROKEN RIVER, AT YIN BARUN

I hereby give notice that I intend to apply for a Licence empowering me to divert water for a term of four years to the extent of 99 megalitres per annum at a maximum rate of 4 megalitres per day of 24 hours for the irrigation of 16.5 hectares of land on allotment 59a Parish of Samaria, and to occupy certain Crown Lands for works of diversion, and to cut a race thereon.

Any objection to such application must be forwarded in writing to reach the State Rivers and Water Supply Commission, Melbourne before 14th October, 1977 being thirty days from the first publication of this Notice.

GARETH RUSH

Mansfield Road, Benalla, 3672 288

**BRIAGOLONG WATERWORKS TRUST
BRIAGOLONG URBAN DISTRICT**

Notice to the owners of tenements in the Streets listed hereunder and in the private streets, lanes, courts and alleys opening thereto:

Landy Street—from Avon Street 112 metres south
McLean Street—from lot 79 207 metres south
Station Street—from McLean Street 121 metres east
Smith Street—from lot 239 59 metres north
Victoria Street—from Smith Street 95 metres west.

The main pipe in the said streets being laid down the owners of all tenements situated as above are hereby required on or before the 31st December, 1977, to cause a proper pipe and stop cocks to be laid as to supply water within such tenements from the main pipe.

J. RENNICK, Secretary
Briagolong Waterworks Trust

306

GEELOG WATERWORKS AND SEWERAGE TRUST

Pursuant to Section 60 of the Geelong Waterworks and Sewerage Act 1958 (No. 6263) the Trust has prepared plans to indicate the particulars of sewers and underground works, the construction of which the Trust intends to begin at a date, not less than one month after publication of the notices, in or adjacent to the following localities within the Drainage Area.

Wilks Street, Thrums and Caddaw Courts, Rowe Street, Tavistock Court and Dunmon Crescent, Bell Post Hill; Shire of Corio.

Edol Street, North Geelong; Shire of Corio.

Wickham Court and Kensington Road, Leopold; Shire of Bellarine.

Notice is hereby given that the plans indicated are open for public inspection at the Trust's offices, 78 Moorabool Street, Geelong, between the hours of 9.00 a.m. and 5.00 p.m. from Monday to Friday (public holidays excepted) by the owners or occupiers of land or premises within the Drainage Area.

272 B. C. HENSHAW, Secretary

FRANKSTON SEWERAGE AUTHORITY

COMMENCEMENT OF WORKS

Notice is hereby given that the Authority intends constructing sewers to serve part of Lot 7 L.P.21627 Lindrum Road and properties abutting thereon.

A map defining the area is available for inspection at the offices of the Authority, Civic Centre Annexe, 34 Davey Street, Frankston, during office hours.

271 ADRIAN BUTLER, Secretary

ECHUCA SEWERAGE AUTHORITY

The Echuca Sewerage Authority has prepared maps and plans showing levels and location of sewers etc. in accordance with the Sewerage Districts Act 1958 for major sewerage extensions to serve existing and future residential and industrial development in the south-eastern portion of the City, such sewers extending from the Plumrose factory site along Echuca-Kyabram Main Road, Newton's Road, Aerodrome Road to the rail crossing, across the Public Purposes Reserve to No. 4 Pumping Station, thence along High Street South, Ogilvie Avenue, Crossen and Elizabeth Streets to the Sewerage Farm.

The maps are now open for inspection at the office of the Authority at the corner of Hare and Heygarth Streets, Echuca, and may be inspected during office hours by owners and occupiers of land or premises in the Sewerage District.

312 K. F. McCARTNEY, Secretary

Notice is hereby given that the partnership heretofore subsisting between Kenneth Norman Mitchell of 8 Farm Road, Cheltenham, Christopher Anthony Morris and Dorothy Cheryl Morris both of 5 Wondalga Avenue, North Dandenong, Allan Charles Mitchell of 22 McLennan Street, Doveton and Colin Frances Mitchell of 2/Messiano Court, Railway Parade, Dandenong carrying on business at Shop D, Centrepoint Arcade, Bourke Street, Melbourne under the style or firm name of Kencriido Imports and at 44 Main Street Box Hill, 68 Young Street Frankston, 365 Lonsdale Street Dandenong, and Shop D, Centrepoint Arcade, Bourke Street Melbourne under the style or firm name of Worldway Imports has been dissolved as from the 1st June 1977 so far as concerns the said Christopher Anthony Morris, Dorothy Cheryl Morris, Allan Charles Mitchell and Colin Francis Mitchell who retire from the said firms.

The said Kenneth Norman Mitchell shall continue the said business under the said names of Kencriido Imports and Worldway Imports.

MICHAEL TAUSSIG, LL.B., barrister and solicitor, 56 Dudley Street, West Melbourne, 3003 263

Notice is hereby given that the partnership heretofore subsisting between William Arthur Wood and Joyce Mary Wood both of 16 Hardy Terrace Ivanhoe in the State of Victoria Enzo Birti of 13 Livingstone Road South Vermont in the said State and Margaret Lillian Birti of Flat 5, No. 38 Lillimur Road Ormond in the said State carrying on the business, of Pastrycooks under the styles or names "Birti Bros." and "Heather Brae Shortbreads" has been dissolved as and from the 1st July 1977 so far as concerns the said Margaret Lillian Birti who retires from the said partnership as and from that date.

PRICE & CHAMBERLIN, solicitors, 180 William Street, Melbourne 359

I. & F. PTY. LTD.

At an Extraordinary General Meeting of the abovenamed Company duly convened and held at the office of H. & H. Guest & Associates Pty. Ltd., 207b Balaclava Road, Caulfield, on the 9th September, 1977, the following Resolution was duly passed as a Special Resolution:

(1) That the Company be wound up voluntarily.
(2) That Mr. John Durlacher, Public Accountant of 207b Balaclava Road, Caulfield be and is hereby appointed liquidator of the Company.

Dated this 9th day of September, 1977

317 J. DURLACHER, Liquidator

Companies Act 1961—CONISTON PROPRIETARY LIMITED (in Voluntary Liquidation)—Notice of Final Meeting, Pursuant to Section 272

Notice is hereby given, pursuant to Section 272 of the Companies Act, that the Final General Meeting of the members of the abovenamed company will be held at the offices of Fell & Starkey, Chartered Accountants, Stock Exchange House, 351 Collins Street, Melbourne on 19 October, 1977 at 10 a.m. for the purpose of having an account laid before it showing the manner in which the winding up has been conducted and the property of the company disposed of, and hearing any explanation that may be given by the liquidator.

Dated this 7th day of September, 1977

329 A. W. ADENA, Liquidator

In the Supreme Court of Victoria—1977 No. Co. 9887—in the matter of the Companies Act 1961; and in the matter of ARMYTAGE SQUARE PTY. LTD.; and in the matter of a Petition dated the 5th day of September, 1977

Notice is hereby given that a Petition for the winding-up of the abovenamed Company by the Supreme Court was on the 6th day of September, 1977 presented by John I. Taylor & Associates, (Vic.) Pty. Ltd. And that the said Petition is directed to be heard before the Court sitting at the Fourteenth Court Law Courts William Street Melbourne on the 21st day of October, 1977 at the hour of 10.30 o'clock in the forenoon; and any creditor or contributory of the said Company desiring to support or oppose the making of an order on the said Petition may appear at the time of hearing by himself or his Counsel for that purpose; and a copy of the Petition will be furnished to any creditor or contributory of the said Company requiring the same by the undersigned on payment of the regulated charge for the same. The Petitioner's address is 464 St. Kilda Road, Melbourne. The Petitioner's Solicitors are Keith Hercules & Sons, of 464 St. Kilda Road, Melbourne.

KEITH HERCULES & SONS, Solicitors for the Petitioner.

NOTE.—Any person who intends to appear on the hearing of the said Petition must serve on or send by post to the abovenamed Solicitors, notice in writing of his intention so to do. The notice must state the name and address of the person, or, if a firm, the name and address of the firm and must be signed by the person or firm, or his or their Solicitor (if any) and must be served, or if posted, must be sent by post in sufficient time to reach the abovenamed not later than 4 o'clock in the afternoon of the 20th day of October, 1977.

330

Companies Act 1961, Section 272

L.H.S. INVESTMENTS PTY. LTD. (IN VOLUNTARY LIQUIDATION)

Notice is hereby given that a general meeting of the Company will be held at 10.00 a.m. on 17th October, 1977 at the office of Hancock & Offner, 1st Floor, 22-28 Davenport Street, Southport for the purpose of laying before it an account showing how the winding up has been conducted and the property of the Company disposed of and giving any explanation thereof.

335

K. CROSS, Liquidator

Companies Act 1961, Section 272 (2)

J.A.T. ENGINEERING PTY. LTD. (IN LIQUIDATION)

NOTICE OF FINAL MEETING

Notice is hereby given that pursuant to Section 272 of the Companies Act 1961, a general meeting of members of J.A.T. Engineering Pty. Ltd. will be held at Messrs. Duesbury Johnston & Marks, 114 William Street, Melbourne on the 17th day of October 1977 at 9.00 a.m.

The purpose of the meeting is to lay accounts before it showing the manner in which the winding up has been conducted and the property of the company disposed of and of hearing any explanation that may be given by the liquidator.

Dated this 13th day of September, 1977

W. A. LEEMING, Liquidator

Duesbury Johnston & Marks, 114 William Street, Melbourne, 3000 336

The Companies Act 1961

CORPORATE CONSTRUCTION CO. PTY. LTD. (IN LIQUIDATION)

NOTICE CONVENING FINAL MEETING OF MEMBERS AND CREDITORS, PURSUANT TO SECTION 272

Notice is hereby given pursuant to Section 272 of the Companies Act 1961, that a general meeting of the members and creditors of the abovenamed company will be held on the 14th day of October, 1977, at 10.30 a.m. in the forenoon at the office of Neville Bird, Davies & Co., Chartered Accountants, 289 Flinders Lane, Melbourne, 3000.

Agenda

1. To lay before the meeting an Account showing the manner in which the winding up has been conducted and the property of the company disposed of, and of hearing any explanation that may be given by the liquidator.

2. To consider and if thought fit, pass a special resolution that all the books and papers of the company and of the liquidator shall be destroyed after three months of the holding of the final meeting or upon dissolution of the company whichever shall last occur.

Dated this 14th day of September, 1977

NEVILLE BIRD, Liquidator

Neville Bird, Davies & Co., chartered accountants, 289 Flinders Lane, Melbourne, 3000. Telephone 63.2874. 337

Companies Act 1961

HIGHBURY CONSTRUCTIONS PTY. LTD.

BALISTER-BRIXTON BUILDERS PTY. LTD.

BERSAL PTY. LTD.

BERSAL PLUMBING PTY. LTD.

HOUSELAND CONSULTANTS PTY. LTD.

MYALLA-RALEIGH PTY. LTD.

NEELOC PTY. LTD.

SALVIC PTY. LTD.

CAPRICE INDUSTRIES PTY. LTD.

NOTICE OF MEETING OF CREDITORS

Notice is hereby given that pursuant to Section 260 (1) of the Companies Act 1961, meetings of creditors of—

Highbury Constructions Pty. Ltd. 10.30 a.m.
Balister-Brixton Builders Pty. Ltd. 2.30 p.m.
Bersal Pty. Ltd. 2.40 p.m.
Bersal Plumbing Pty. Ltd. 2.50 p.m.
Houseland Consultants Pty. Ltd. 3.00 p.m.
Myalla-Raleigh Pty. Ltd. 3.20 p.m.
Neeloc Pty. Ltd. 3.30 p.m.
Salvic Pty. Ltd. 3.40 p.m.
Caprice Industries Pty. Ltd. 4.00 p.m.

will be held at 461 Bourke Street, Melbourne on the 30th day of September, 1977 at the times noted beside their names.

The Company having convened a meeting of its members for the same day for the purpose of considering a Special Resolution that the Company be wound up voluntarily.

Dated this 8th day of September, 1977

R. L. SALLOWS, Director

Coopers & Lybrand, chartered accountants, 461 Bourke Street, Melbourne, Vic. 3000 316

The Companies Act 1961

LES MASON GRAPHIC DESIGN PTY. LTD. (IN LIQUIDATION)

NOTICE CONVENING FINAL MEETING OF MEMBERS AND CREDITORS, PURSUANT TO SECTION 272

Notice is hereby given in pursuance of section 272 of the Companies Act 1961 that a meeting of the Members and Creditors of the abovenamed company will be held on Friday 21st October 1977 at 9.00 a.m. at the office of Fordham, Williams & Co., Chartered Accountants, 521 Toorak Road, Toorak, for the purpose of having an account laid before them showing the manner in which the winding up has been conducted and the property of the Company disposed of and of hearing any explanations that may be given by the liquidator.

Dated this 7th day of September, 1977

FORDHAM, WILLIAMS & CO., chartered accountants, 521 Toorak Road, Toorak, 3142. Telephone 24 7511 286

In the Supreme Court of Victoria—1977 Co. 9880—In the matter of the Companies Act 1961; and in the matter of SPECIAL MOTOR PANEL PTY. LTD.

Notice is hereby given that a Petition for the Winding-Up of the abovenamed Company by the Supreme Court was on the 2nd day of September 1977 presented by, Leo Thomas FitzGerald, Deputy Commissioner of Taxation of the Commonwealth of Australia and that the said Petition is directed to be heard before the Court sitting at the Thirteenth Court, Law Courts, William Street, Melbourne at the hour of 10.30 o'clock in the forenoon on the 30th day of September 1977 and any creditor or contributory of the said Company desiring to support or oppose the making of an order on the said Petition may appear at the time of hearing by himself or his Counsel for the purpose; and a copy of the said Petition will be furnished to any creditor or contributory of the said Company requiring the same by the undersigned on payment of the regulated charge for the same.

The Petitioner's official address is 350 Collins Street, Melbourne.

The Petitioner's solicitor is Alan R. Neaves, Crown Solicitor for the Commonwealth of 99 Queen Street, Melbourne.

ALAN R. NEAVES

NOTE.—Any person who intends to appear on the hearing of the said Petition must serve on or send by post to the abovenamed Alan R. Neaves notice in writing of his intention so to do. The notice must state the name and address of the person, or, if a firm, the name and address of the firm, and must be signed by the person or firm, or his or their solicitor (if any) and must be served, or if posted must be sent by post in sufficient time to reach the abovenamed not later than 4 o'clock in the afternoon of the 29th day of September, 1977. 372

In the Supreme Court of Victoria—1977 Co. 9881—In the matter of the Companies Act 1961; and in the matter of THE TOTAL THEATRE PTY. LTD.

Notice is hereby given that a Petition for the Winding-Up of the abovenamed Company by the Supreme Court was on the 2nd day of September 1977 presented by Kevin Patrick Brady, Deputy Commissioner of Taxation of the Commonwealth of Australia and that the said Petition is directed to be heard before the Court sitting at the Thirteenth Court, Law Courts, William Street, Melbourne at the hour of 10.30 o'clock in the forenoon on the 30th day of September 1977 and any creditor or contributory of the said Company desiring to support or oppose the making of an order on the said Petition may appear at the time of hearing by himself or his Counsel for the purpose; and a copy of the said Petition will be furnished to any creditor or contributory of the said Company requiring the same by the undersigned on payment of the regulated charge for the same.

The Petitioner's official address is 350 Collins Street, Melbourne.

The Petitioner's solicitor is Alan R. Neaves, Crown Solicitor for the Commonwealth of 99 Queen Street, Melbourne.

ALAN R. NEAVES

NOTE.—Any person who intends to appear on the hearing of the said Petition must serve on or send by post to the abovenamed Alan R. Neaves notice in writing of his intention so to do. The notice must state the name and address of the person, or, if a firm, the name and address of the firm, and must be signed by the person or firm, or his or their solicitor (if any) and must be served, or if posted must be sent by post in sufficient time to reach the abovenamed not later than 4 o'clock in the afternoon of the 29th day of September, 1977. 371

In the Supreme Court of Victoria—1977 Co. 9882—In the matter of the Companies Act 1961; and in the matter of FREE FLOW INVESTMENTS PTY. LTD.

Notice is hereby given that a Petition for the Winding-Up of the abovenamed Company by the Supreme Court was on the 2nd day of September 1977 presented by Leo Thomas FitzGerald, Deputy Commissioner of Taxation of the Commonwealth of Australia and that the said Petition is directed to be heard before the Court sitting at the Thirteenth Court, Law Courts, William Street, Melbourne at the hour of 10.30 o'clock in the forenoon on the 30th day of September 1977 and any creditor or contributory of the said Company desiring to support or oppose the

making of an order on the said Petition may appear at the time of hearing by himself or his Counsel for the purpose; and a copy of the said Petition will be furnished to any creditor or contributory of the said Company requiring the same by the undersigned on payment of the regulated charge for the same.

The Petitioner's official address is 350 Collins Street, Melbourne.

The Petitioner's solicitor is Alan R. Neaves, Crown Solicitor for the Commonwealth of 99 Queen Street, Melbourne.

ALAN R. NEAVES

NOTE.—Any person who intends to appear on the hearing of the said Petition must serve on or send by post to the abovenamed Alan R. Neaves notice in writing of his intention so to do. The notice must state the name and address of the person, or, if a firm, the name and address of the firm, and must be signed by the person or firm, or his or their solicitor (if any) and must be served, or if posted must be sent by post in sufficient time to reach the abovenamed not later than 4 o'clock in the afternoon of the 29th day of September, 1977. 370

In the matter of EDWARD PHILLIP MOTORS PTY. LTD.—Notice of Winding Up Order.

Winding-Up Order Made: The 6th day of September, 1977.

Name and Address of Liquidator: Geoffrey Ormond Harrison of 440 Collins Street, Melbourne.

PHILLIPS, FOX & MASEL, solicitors for petitioner 345

Company No. 45248—Companies Act 1961—In the matter of LE MANS CYCLES PTY. LTD. (in Voluntary Liquidation)

Notice is hereby given that at an Extra-ordinary General Meeting of the members of the abovenamed Company held on the 12th September 1977, it was resolved that the Company be wound up voluntarily and that Messrs. R. G. Cameron and N. K. Cuthbert, of W. Marshall & Associates, of Suite 2, 162 Albert Road, South Melbourne, Chartered Accountants be appointed Liquidators.

Notice is also given that after twenty-one days from this date we shall proceed to distribute the assets. All creditors having any claims against the Company should furnish particulars of same by that date, otherwise we shall proceed to distribute the assets without regard to their claim.

Dated this 12th day of September, 1977.

360 R. G. CAMERON, Liquidator
N. K. CUTHBERT, Liquidator

In the Supreme Court of Victoria—1977 Co. 9883—In the matter of the Companies Act 1961 and in the matter of SWINTON & WHITE PTY. LTD.

Notice is hereby given that a Petition for the Winding-Up of the abovenamed Company by the Supreme Court was on the 2nd day of September 1977 presented by Kevin Patrick Brady, Deputy Commissioner of Taxation of the Commonwealth of Australia and that the said Petition is directed to be heard before the Court sitting at the Thirteenth Court, Law Courts, William Street, Melbourne at the hour of 10.30 o'clock in the forenoon on the 30th day of September 1977 and any creditor or contributory of the said Company desiring to support or oppose the making of an order on the said Petition may appear at the time of hearing by himself or his Counsel for the purpose; and a copy of the said Petition will be furnished to any creditor or contributory of the said Company requiring the same by the undersigned on payment of the regulated charge for the same.

The Petitioner's official address is 350 Collins Street, Melbourne.

The Petitioner's solicitor is Alan R. Neaves, Crown Solicitor for the Commonwealth of 99 Queen Street, Melbourne.

ALAN R. NEAVES

NOTE.—Any person who intends to appear on the hearing of the said Petition must serve on or send by post to the abovenamed Alan R. Neaves notice in writing of his intention so to do. The notice must state the name and address of the person, or, if a firm, the name and address of the firm, and must be signed by the person or firm, or his or their solicitor (if any) and must be served, or if posted must be sent by post in sufficient time to reach the abovenamed not later than 4 o'clock in the afternoon of the 29th day of September 1977. 369

In the Supreme Court of Victoria—1977 Co. 9884—In the matter of the Companies Act 1961 and in the matter of K. & R. BUILDING SERVICES PTY. LTD.

Notice is hereby given that a Petition for the Winding-Up of the abovenamed Company by the Supreme Court was on the 2nd day of September 1977 presented by Kevin Patrick Brady, Deputy Commissioner of Taxation of the Commonwealth of Australia and that the said Petition is directed to be heard before the Court sitting at the Thirteenth Court, Law Courts, William Street, Melbourne at the hour of 10.30 o'clock in the forenoon on the 30th day of September 1977 and any creditor or contributory of the said Company desiring to support or oppose the making of an order on the said Petition may appear at the time of hearing by himself or his Counsel for the purpose; and a copy of the said Petition will be furnished to any creditor or contributory of the said Company requiring the same by the undersigned on payment of the regulated charge for the same.

The Petitioner's official address is 350 Collins Street, Melbourne.

The Petitioner's solicitor is Alan R. Neaves, Crown Solicitor for the Commonwealth, of 99 Queen Street, Melbourne.

ALAN R. NEAVES

NOTE.—Any person who intends to appear on the hearing of the said Petition must serve on or send by post to the abovenamed Alan R. Neaves notice in writing of his intention so to do. The notice must state the name and address of the person, or, if a firm, the name and address of the firm, and must be signed by the person or firm, or his or their solicitor (if any) and must be served, or if posted must be sent by post in sufficient time to reach the abovenamed not later than 4 o'clock in the afternoon of the 29th day of September 1977.

I, Gordon Douglas Metcalfe, of 17 Lydiard Street North, Ballarat, liquidator of Hames and Woodward Pty. Ltd. (in voluntary liquidation), hereby advise that a general meeting of Members and Creditors of the company is summoned for 4.30 p.m. on Wednesday 19th October, 1977 at 10 Brawn Avenue, Ballarat, for the purpose of laying before the meeting an account showing how the winding up has been conducted, and the property of the company has been disposed of, and giving any explanation regarding the account.

The Companies Act 1961—In the matter of BUNTON & GRAU PTY. LTD., (in Voluntary Liquidation)—Notice of Final Meeting

Notice is hereby given that, pursuant to Section 272 of the Companies Act 1961, a General Meeting of the Members of the above-named Company will be held at the office of L. Rosner & Associates, 37 Swanston Street, Melbourne on the 17th October, 1977 at 11 a.m. for the purpose of having an account laid before them showing the manner in which the winding up has been conducted and the property of the Company disposed of, and of hearing any explanation that may be given by the liquidator.

Dated the 9th day of September, 1977

M. E. ROSNER, Liquidator

L. Rosner and Associates; public accountants, 37 Swanston Street, Melbourne, 3000

In the matter of CUTTING EDGES (VIC.) PTY. LIMITED and in the matter of the Companies Act 1961

Take notice that the abovenamed company on the 29th day of August, 1977 duly resolved by special resolution that it be wound up voluntarily.

5th September, 1977

305 W. J. GREGORY, Secretary

In the matter of the Companies Act 1961; and in the matter of BARNATO COURT PTY. LTD. (in Liquidation)

Notice is hereby given that pursuant to Section 272 of the Companies Act 1961, the final meeting of the members of the Company will be held at 10 Queens Road, Melbourne on the eighteenth day of October, 1977 at 9.30 a.m. for the purpose of laying before the meeting the account of the winding up and any explanation thereof.

Dated this 9th day of September, 1977.

L. M. FYSH, Liquidator, Barnato Court Pty. Ltd. (in Liquidation) 292

Companies Act 1961

MARTREB PTY. LTD.

NOTICE OF MEETING OF CREDITORS

Notice is hereby given that pursuant to Section 260 (1) of the Companies Act 1961, meetings of creditors of Martreb Pty. Ltd. 3.10 p.m. will be held at 461 Bourke Street, Melbourne on the 30th day of September, 1977 at the time noted beside its name.

The company having convened a meeting of its members for the same day for the purpose of considering a Special Resolution that the Company be wound up voluntarily.

Dated this 8th day of September, 1977

B. GAINE, Director

Coopers & Lybrand, chartered accountants, 461 Bourke Street, Melbourne, Vic. 3000 315

In the matter of the Companies Act 1961; and in the matter of T.H.S. HOLDINGS PTY. LTD. (in Liquidation)

Notice is hereby given that pursuant to Section 272 of the Companies Act 1961, the final meeting of the members of the Company will be held at 10 Queens Road, Melbourne on the eighteenth day of October, 1977 at 9.30 a.m. for the purpose of laying before the meeting the account of the winding up and any explanation thereof.

Dated this 9th day of September, 1977

L. M. FYSH, Liquidator, T.H.S. Holdings Pty. Ltd. (in Liquidation) 293

In the matter of the Companies Act 1961; and in the matter of B.M.S. HOLDINGS PTY. LTD. (in Liquidation)

Notice is hereby given that pursuant to Section 272 of the Companies Act 1961, the final meeting of the members of the Company will be held at 10 Queens Road, Melbourne on the eighteenth day of October, 1977 at 9.30 a.m. for the purpose of laying before the meeting the account of the winding up and any explanation thereof.

Dated this 9th day of September, 1977

L. M. FYSH, Liquidator, B.M.S. Holdings Pty. Ltd. (in Liquidation) 294

Companies Act 1961

COBHAM CONSTRUCTIONS PTY. LTD. (IN LIQUIDATION)

NOTICE CONVENING FINAL MEETING, PURSUANT TO SECTION 272 (1)

Notice is hereby given that the Final Meeting of Members and Creditors of the above named company will be held at the offices of Shepherd & Partners, 3rd Floor, 969 Burke Road, Camberwell on Thursday, 20th October, 1977 at 10.00 a.m. for the purpose of laying before the meeting an account showing how the winding up has been conducted and the property of the company disposed of and giving any explanation thereof.

Dated this 7th day of September, 1977

M. B. CRABB, Liquidator

Shepherd & Partners, chartered accountants, 3rd Floor, 969 Burke Road, Camberwell, 3124 264

W. A. O'DONNELL PTY. LTD. (IN VOLUNTARY LIQUIDATION)

Notice is hereby given, pursuant to section 272 of the Companies Act 1961, that a General Meeting of the members of the abovenamed Company will be held at the offices of Ronald A. Sparks, 286 Toorak Road, South Yarra on 14th day of October 1977 at 11.30 a.m., for the purpose of having an account laid before them, showing the manner in which the winding up has been conducted and the property of the Company disposed of, and of hearing any explanation that may be given by the liquidator.

Dated this 6th day of September, 1977

265 RONALD A. SPARKS, Liquidator

In the Supreme Court of Victoria—1977 Co. No. 9787—In the matter of the Companies Act 1961; and in the matter of MURLAW PTY. LIMITED—Notice of Winding Up Order

Winding-Up Order Made: 24th day of August, 1974.

Name and Address of Liquidator: Robert Eastaugh Ramsay, care of Wallace, McMullin & Smail, of 499 St. Kilda Road, Melbourne.

A. E. WUNDELE & CO., solicitors for the petitioner 266

The Companies Act 1961
MARSHALL & MAYNE PROPRIETARY LIMITED (IN LIQUIDATION)

NOTICE CONVENING FINAL MEETING OF MEMBERS AND CREDITORS, PURSUANT TO SECTION 272

Notice is hereby given pursuant to Section 272 of the Companies Act 1961, that a General Meeting of the members and the creditors of the abovenamed company will be held in the offices of Wallace, McMullin & Smail, 499 St. Kilda Road, Melbourne 3004 on Wednesday the Twelfth day of October, 1977, at 10.00 a.m. for the purpose of having an account laid before them showing the manner in which the winding up has been conducted and the property of the company disposed of and of hearing any explanations that may be given by the Liquidator.

Dated this 17th day of September, 1977
338 JOHN MARTIN WALSH, Liquidator

The Companies Act 1961
YOUR CAMPING WORLD PROPRIETARY LIMITED (IN LIQUIDATION)

NOTICE CONVENING FINAL MEETING OF MEMBERS AND CREDITORS, PURSUANT TO SECTION 272

Notice is hereby given pursuant to Section 272 of the Companies Act 1961, that a General Meeting of the members and creditors of the abovenamed company will be held in the offices of Wallace, McMullin & Smail, 499 St. Kilda Road, Melbourne, 3004, on Wednesday the Twelfth day of October, 1977, at 10.30 a.m. for the purpose of having an account laid before them showing the manner in which the winding up has been conducted and the property of the company disposed of and of hearing any explanations that may be given by the Liquidator.

Dated this 7th day of September, 1977
339 ROBERT EASTAUGH RAMSAY, Liquidator

Companies Act 1961
MOTOR TRANSPORT INVESTMENT PTY. LTD. (IN VOLUNTARY LIQUIDATION)

NOTICE CONVENING FINAL MEETING OF MEMBERS, PURSUANT TO SECTION 272

Notice is hereby given in pursuance of Section 272 of the Companies Act 1961 that a General Meeting of the Members of the abovenamed company will be held on the 18th October, 1977 at 11.00 a.m. at the office of Hughes, Fincher & Rodda, 343 Little Collins Street, Melbourne, for the purpose of having an account laid before them showing the manner in which the winding up has been conducted and the property of the Company disposed of and hearing any explanation that may be given by the Liquidator.

Dated this 9th day of September, 1977
N. HARRIS, Liquidator
Hughes, Fincher & Rodda, chartered accountants, 343 Little Collins Street, Melbourne, Vic. 3000 340

The Companies Act 1961—In the matter of WESTCENTRAL PASTORAL PTY. LTD.

Notice is hereby given that I have fixed the 10th October 1977 as the final date by which creditors of the abovenamed company are required to prove their debts in this Scheme of Arrangement.

Dated this 12th day of September, 1977
R. P. TREVASKIS, scheme trustee, Room 12, 1st Floor, Block Arcade, 98 Elizabeth Street, Melbourne, 3000 361

The Companies Act 1961
JACK BENNY OF MELBOURNE PTY. LTD.
NOTICE OF MEETING OF CREDITORS

Notice is hereby given that pursuant to section 260 of the Companies Act 1961 a meeting of the creditors of Jack Benny of Melbourne Pty. Ltd. will be held in the Boardroom of the Institute of Chartered Accountants, 140 Queen Street, Melbourne on the 23rd day of September 1977 at 9.30 a.m. the Company having convened a meeting of its members for the same day for the purpose of considering, and if thought fit, passing a special resolution that the Company be wound up voluntarily.

Dated this 14th day of September, 1977
J. M. ESAKOFF, Director
Duesbury, Johnston & Marks, chartered accountants, 114 William Street, Melbourne, Vic., 3000 362

The Companies Act 1961—In the matter of KING ISLAND PASTORAL CO. PTY. LTD.

Notice is hereby given that at an Extraordinary General Meeting of the Members of the abovenamed Company held on the 7th day of September, 1977, it was resolved that the Company be wound up voluntarily, as a Members Voluntary Winding Up pursuant to the provisions of Sub-division 2 of Division 3 of Part X of the Companies Act 1961, and it was further resolved that for such purpose Thomas Andrew Latham of 704 Hawthorn Road, East Brighton, be appointed Liquidator.

Notice is also given that after twenty-one days from this date I shall proceed to distribute the assets. Any creditors having any claims against the Company should furnish particulars of same by that date, otherwise I shall proceed to distribute the assets without regard to their claim.

Dated this 8th day of September, 1977
T. A. LATHAM, Liquidator

Wallace McMullin & Smail, chartered accountants, 499 St. Kilda Road, Melbourne, 3004 341

The Companies Act 1961, Section 272
HARDING & AYRES PTY. LTD. (IN VOLUNTARY LIQUIDATION)
MEMBERS' VOLUNTARY WINDING UP

Notice is hereby given that the Final General Meeting of Members of the above-named Company for the purpose of receiving the Liquidator's account showing how the winding up has been conducted and how the property of the Company has been disposed of, will be held at 203 Moorabool Street, Geelong on Wednesday 19th October, 1977, at 2 p.m.

Dated at Geelong this 12th day of September, 1977
R. PEAKE, Liquidator
Day, Neilson, Jenkins & Johns, chartered accountants, 199-203 Moorabool Street, Geelong, 3220 346

Companies Act 1961—In the matter of HAIGH RESISTANCES PROPRIETARY LIMITED

Notice is hereby given that pursuant to Section 260 (1) of the Companies Act 1961, a meeting of creditors of the above company will be held at 18th Floor, 461 Bourke Street, Melbourne on the 4th day of October, 1977 at 10.00 a.m. The company having convened a meeting of its members for the same day for the purpose of considering a Special Resolution that the company be wound up voluntarily.

Dated this 9th day of September, 1977
L. D. TRAPNELL, Director
Coopers & Lybrand, chartered accountants, 461 Bourke Street, Melbourne, Vic. 3000 351

The Companies Act 1961
HUME INVESTMENTS PTY. LTD. (IN VOLUNTARY LIQUIDATION)
NOTICE OF FINAL MEETING

Notice is hereby that pursuant to section 272 of the Companies Act 1961 a General Meeting of Members of Hume Investments Pty. Ltd. will be held at the Offices of Touche Ross & Co., 440 Collins Street, Melbourne, on the 17th day of October, 1977, at 9.30 a.m. for the purpose of laying before it accounts showing how the winding up has been conducted and the property of the Company has been disposed of and of hearing any explanations that may be given by the Liquidators.

E. M. HUGGARD,
B. A. WATERS,
365 Joint and Several Liquidators

Companies Act 1961—In the matter of LAUNDERERS PTY. LTD.—Members' Winding Up

Notice is hereby given pursuant to Section 272 of the Companies Act that the Final General Meeting of the members of the abovenamed company will be held on 10th Floor, 44 Market Street, Melbourne, on 28th October 1977 at 9.00 a.m. when I shall lay before the meeting an account of how the winding up has been conducted and how the property of the Company has been disposed of.

Dated 14th September, 1977
E. H. NIEMANN, Liquidator
366

The Companies Act 1961

REO JEANS PTY. LTD.

NOTICE OF MEETING OF CREDITORS

Notice is hereby given that pursuant to section 260 of the Companies Act 1961 a meeting of the creditors of Reo Jeans Pty. Ltd. will be held in the Boardroom of the Institute of Chartered Accountants, 140, Queen Street, Melbourne on the 23rd day of September, 1977 at 10.30 a.m. the Company having convened a meeting of its members for the same day for the purpose of considering, and if thought fit, passing a special resolution that the Company be wound up voluntarily.

Dated this 14th day of September, 1977

J. M. ESAKOFF, Director

Duesbury, Johnston & Marks, chartered accountants, 114 William Street, Melbourne, Vic., 3000 363

Companies Act 1961

CANN'S PTY. LTD. (IN LIQUIDATION)

Notice is hereby given that a meeting of the Creditors of the above company will be held in the Board Room, Institute of Chartered Accountants in Australia, 140 Queen Street, Melbourne on Thursday 29th September 1977 at 11.00 a.m.

Agenda

1. To further consider continuation of the present legal action, dependent on contributions by creditors to a trust fund, separate from the liquidator's general account.

2. To appoint a Committee of Inspection.

To enable you to vote at the meeting, your Proof of Debt, if not already lodged, must be lodged with me on or prior to 28th September 1977.

Dated this 14th day of September, 1977

A. J. GAIRNS, Official Liquidator, 343 Little Collins Street, Melbourne, Vic., 3000 364

In the Supreme Court of Victoria—1977 Co. 9849—In the matter of the Companies Act 1961; and in the matter of HAUBE PTY. LTD.—Notice of Winding Up Order

Winding-up Order: Made 6th September 1977

Name and Address of Liquidator: Kevin James Browne of 1 Palmerston Crescent, South Melbourne

ALAN R. NEAVES, Crown Solicitor for the Commonwealth and Solicitor for the Petitioner 367

CAMPION, LEONARD JAMES FRANCIS; Flat 5, 5 Williams Court, Richmond; Victoria, 3121

Dependants, legal personal representatives and others having claims under the Carlton and United Breweries Employees Superannuation Scheme to the benefit on the life of the above-named deceased who died on 11th August, 1977, are required by the Trustees of the Scheme, Messrs. Philip Renton Power, James William Bennett and Timothy Noel Plant all of 16 Bouverie Street, Carlton, Victoria to send particulars to them by the 30th day of November, 1977 after which date the Trustees may distribute the benefit, having regard only to the claims of which they then have notice.

"Dependants" within the meaning of the Trust Deed means the wife, widow and children of the deceased and any other persons who in the opinion of the Trustees are dependent upon the deceased.

Dated 12th September, 1977

M. A. HAINES, secretary to the trustees 318

Creditors next of kin and others having claims in respect of the Estate of Frank William Crooks, late of 17 Douglas Street Blackburn North in the State of Victoria teacher deceased intestate who died on the 29th day of April 1977 are required by Annette Joy Crooks of 17 Douglas Street, Blackburn, North in the said State Widow of the said deceased, the Administratrix to whom Letters of Administration were granted by the Supreme Court of Victoria on the 5th day of September 1977 to send particulars of their claims to the said Administratrix care of the undermentioned solicitor by the 18th day of November 1977 after which date she will distribute the assets having regard only to the claims of which she shall then have had notice.

LAURENCE W. HAMER, solicitor, 349 Collins Street, Melbourne, 3000 281

Creditors next of kin and other having claims against the estate of Evelyn Jane McWilliam formerly of 557 Victoria Street Brunswick but late of Alimar Private Hospital Pty. Ltd., 34 Scott Street Essendon Spinster deceased who died on the 25th August 1976 are required to send particulars of their claims to the Trustee Alastair Wallace Farrie McWilliam care of the undermentioned Solicitor by the 6th December, 1977 after which date he will proceed to distribute the estate having regard only to the claims of which he then has notice.

J. R. HOBAN, solicitor, of 47 O'Shannassy Street, Sunbury 319

Creditors, next-of-kin and others having claims in respect of the estate of Annette Christina Young late of 1268 North Road, Huntingdale Widow deceased (who died on the 20th February, 1977) are required to send particulars of their claims to the Executor Frederick Archdale Lester, care of the undermentioned Solicitors by the 16th day of November, 1977 after which date he will distribute the assets having regard only to the claims of which he then has notice.

LESTER, PEARN & FIELDEN, solicitors, 14 Haughton Road, Oakleigh 280

ALEXANDER WOLWACH, formerly of 29 Rockbank Road, Ardeer, but late of Lot 3 Robinsons Road, Baxter, retired, DECEASED

Creditors, next of kin and others having claims in respect of the estate of the deceased (who died on the 1st day of July, 1977) are required to send particulars of their claims to Jan Skorobagaty, John Podolak and Paul Shramchenko, care of F. P. & M. J. Walsh, Solicitors, of 452 High Street, Northcote before the 16th day of November, 1977 after which date they will distribute the assets, having regard only to the claims of which they then have notice.

F. P. & M. J. WALSH, solicitors, 452 High Street, Northcote 282

WILLIAM CHARLES GRAHAM, late of 83 Jenkins Street, Northcote, retired, DECEASED

Creditors, next of kin and others having claims in respect of the estate of the deceased (who died on the 22nd day of July, 1977) are required to send particulars of their claims to Colin Graham, care of F. P. & M. J. Walsh, Solicitors of 452 High Street, Northcote before the 16th day of November, 1977 after which date he will distribute the assets having regard only to the claims of which he then has notice.

F. P. & M. J. WALSH, solicitors, 452 High Street, Northcote 283

KATHLEEN MARY MORRISSEY, late of 98 South Crescent, Dennis, spinster, DECEASED

Creditors next of kin and others having claims in respect of the estate of the deceased (who died on the 17th day of March, 1977) are required to send particulars of their claims to National Trustees Executors and Agency Company of Australasia Limited of 95, Queen Street, Melbourne before the 16th day of November, 1977 after which date it will distribute the assets having regard only to the claims of which it then has notice.

F. P. & M. J. WALSH, solicitors, 452 High Street, Melbourne 284

MARJORIE FAIRBAIRN BELL, late of Flat 11, Elgin Avenue, Armadale, widow, DECEASED

Creditors next of kin and others having claims against the Estate of the said deceased who died on 24th April 1977 are to send particulars of their claims to Mary Margaret Wilbur Ham and Bernard Gore Brett care of, Blake & Riggall 140 William Street Melbourne by the 16th day of November 1977 after which date they will distribute the assets having regard only to the claims of which they then have notice.

BLAKE & RIGGALL, solicitors, 140 William Street, Melbourne 378

EDITH GRACE EMERY, late of 66 Naples Road, Mentone, widow, DECEASED

Creditors next of kin and others having claims against the Estate of the said deceased who died on 5th April 1977 are to send particulars of their claims to Grace Mary McGrady care of Blake & Riggall, 140 William Street Melbourne by the 16th day of November 1977 after which date she will distribute the assets having regard only to the claims of which she then has notice.

BLAKE & RIGGALL, solicitors, 140 William Street, Melbourne 379

WILLIAM CHARLES CALDWELL, formerly of 38 Beveridge Street, Swan Hill, in the State of Victoria, but late of 116 Curlewis Street, Swan Hill, aforesaid, formerly salesman, but late retired salesman, DECEASED

Creditors next-of-kin and other persons having claims against the Estate of the said Deceased who died on the 17th day of July, 1977 are required to send particulars of same to the Administratrix Lillian Hazel Hickey in care of the undersigned on or before the 9th day of November, 1977 after which date she will distribute the assets having regard only to the claims of which she then has notice.

DWYER, CLARKE & BENNETT, barristers and solicitors, 201 Campbell Street, Swan Hill 320

Creditors next of kin and others having claims in respect of the estate of Ivy Begbie late of 25 Serrell Street East Malvern Widow deceased who died on the 5th day of June 1977 and Probate of whose Will has been granted to Evelyn Jean Begbie Wood of 60 Pender Street Thornbury and Noela Eadith Snell of 43 Scott Street Vermont Married Women are required to send particulars of their claims to the said Executrices care of the undermentioned Solicitors by the 18th day of November 1977 after which date they will distribute the assets having regard only to the claims of which they then have notice.

PEARCE & WEBSTER, solicitors, 430 Little Collins Street, Melbourne 321

Creditors next-of-kin and others having claims in respect of the estate of Ercole Nicole Ruscitti late of 23 Rourke Street, Lilydale Retired deceased who died on the 17th June, 1977 are required by Livio Domenico Cellante of 61 Darvall Street, Donvale Civil Engineer the Applicant for a grant of Probate of the said deceased's Will to send particulars of their claims to him care of the undermentioned Solicitors by the 21st November, 1977 after which date he will distribute the assets having regard only to the claims of which he then has notice.

J. W. GLOVER & CO., solicitors, 422 Collins Street, Melbourne 296

PEGGY DAVIES, late of Ellinbank, married woman, DECEASED

Creditors next of kin and others having claims in respect to the estate of the deceased who died on the 6th day of January 1977 are requested by the Trustee Owen Edwin Davies to send particulars of their claims to him care of the undersigned Solicitors by the 23rd day of November 1977 after which date the Trustee may convey or distribute the assets having regard only to the claims of which he then has notice.

GRAY FRIEND & LONG, solicitors, Warragul 297

EDWARD CARROLL, late of 702B Dana Street, Ballarat, retired basket maker, DECEASED, who died on the 22nd April, 1977

Creditors next of kin and all other persons having claims against the Estate of the said deceased are required by the Executor The Union-Fidelity Trustee Company of Australia Limited of 100 Exhibition Street Melbourne to send detailed particulars of their claims in respect of the said property to the said Executor care of the said company at 101 Lydiard Street North Ballarat on or before the 14th November 1977 after which date it will proceed to distribute the said Estate having regard only to the claims of which it then has notice.

Dated this 14th day of September, 1977

RAMSAY, GAUNT & FRASER, of 41 Lydiard Street, South Ballarat, solicitors for the executor 299

STANLEY GORDON YEOMAN, late of 35 Davis Street, Belmont, Geelong, maintenance engineer, DECEASED

Creditors next of kin and others having claims in respect of the estate of the said deceased who died 6th June 1977 are required by the applicant for grant of probate of the will Frederick William Yeoman of 35 Cairns Avenue Newtown Retired Assistant Supervisor to send particulars to him care of the undersigned solicitors by 23rd November 1977 after which date the said applicant may convey or distribute the assets having regard only to the claims of which he then has notice.

WIGHTON & MCDONALD, solicitors, 89 Myers Street, Geelong 304

GEORGE INGRAM WEBB, late of 81 Albert Street, Warragul, retired postal employee, DECEASED

Creditors next of kin and others having claims in respect to the estate of the deceased who died on the 22nd day of May 1977 are requested by the Trustee Eva Roberta May Webb to send particulars of their claims to her care of the undersigned Solicitors by the 23rd day of November 1977 after which date the Trustee may convey or distribute the assets having regard only to the claims of which she then has notice.

GRAY FRIEND & LONG, solicitors, Warragul 298

Creditors next of kin and others having claims against the estate of Harold Logan Hodge late of 22 Arnold Road East Brighton Technical Manager deceased who died on the 23rd May 1977 are required by the Executrix Venora Judith Hodge of 22 Arnold Road East Brighton Widow deceased to send particulars to her at the office of the undersigned Solicitors on or before 15th November 1977 after which date she will distribute the assets having regard only to the claims of which she shall then have had notice.

A. NEWTON SUPER & P. G. KOVACS, barristers and solicitors, 374 Bourke Street, Melbourne 301

DORIS MAY RASMUSSEN, late of 67 Hall Street, McKinnon, widow, DECEASED

Creditors, next-of-kin and others having claims in respect of the estate of the abovenamed deceased who died on 11th December 1976, are required by the trustee Nancy Victoria Harcourt of 8 Tulip Street, Violet Town, Married Woman, to send particulars to her solicitors, Nunan & Bloom at their address below by 28th November 1977 after which date the trustee may convey or distribute the assets having regard only to the claims of which she then has notice.

NUNAN & BLOOM, solicitors, 343 Little Collins Street, Melbourne 303

Creditors next of kin and others having claims against the estate of Charlotte Eleanor Leslie formerly of 8 Nicholson Street Nunawading Married Woman, but late of Flat 71, 50 King William Street Fitzroy Victoria Widow deceased, who died on the 25th May 1977 are required to send particulars of their claims to the Executor of her Will Alan Keith Wright care of the undermentioned Solicitors before the 1st day of February 1978 after which date the said Executor will distribute the estate of the said deceased having regard only to the claims of which he had then notice.

KAHN AND CLAHR, solicitors, 213 Lonsdale Street, Melbourne, 3000 289

Creditors next of kin and others having claims against the Estate of Henrietta Jane Crippin late of 11 Grace Street, Malvern, Spinster deceased, who died on the 27th day of August, 1977 are required by the Executrix of her will to send particulars of their claims to the said Executrix in the care of the undermentioned Solicitor by the 18th day of November, 1977, after which date the said Executrix will distribute the assets having regard only to the claims of which she then has notice.

VERA A. FOWLER, solicitor, 1 Evandale Road, Malvern. 290

Creditors next of kin and others having claims against the Estate of Wilfred West Satchell formerly of 20 Johnstone Street, Malvern but late of 12 Waringa Crescent, Mount Eliza Gentleman deceased, who died on the 23rd day of August, 1977, are required by the Executrix of his will to send particulars of their claims to the said Executrix in the care of the undermentioned Solicitor by the 18th day of November, 1977, after which date the said Executrix will distribute the assets having regard only to the claims of which she then has notice.

VERA A. FOWLER, solicitor, 1 Evandale Road, Malvern. 291

Creditors next of kin and others having claims against the estate of Jessie Simpson late of 172 Princes Highway Drouin Widow deceased who died on the 2nd day of June 1977 are requested to send particulars of their claims to Phillip James Gunn of 20 Murawa Street Frankston Buyer the Executor of the Will of the said deceased in care of the undersigned by the 16th day of November 1977 after which date he will distribute the assets having regard only to the claims of which he then shall have had notice.

M. DAVINE & CO., solicitors, Warragul 260

BERNARD JOHN DOWD, late of "Craigie Lea", Beach Road, Mornington, rural managing director, DECEASED

Creditors next of kin and others having claims in respect of the estate of the deceased who died on the Twenty-sixth day of December, 1976 are required by The Perpetual Executors and Trustees Association of Australia Limited of 50 Queen Street, Melbourne and Roma Wenlock Dowd of "Craigie Lea", Beach Road, Mornington Rural Widow the applicants for a grant of administration to send particulars of their claims to the said applicants in the care of the said Company by the 16th day of November, 1977 after which date they will convey or distribute the assets having regard only to the claims of which they then have notice.

CORR & CORR, solicitors, 290 La Trobe Street, Melbourne 322

Creditors, Next-of-kin and others having claims in respect of the Estate of Alfred Thomas Tampion Daglish formerly of 41 Whittens Lane, Doncaster in the State of Victoria but late of 157 Male Street, Brighton in the said State Retired Secondary School Teacher deceased, who died on the 21st day of May 1977 are required to send particulars of their claims to the Executor, The Trustees Executors and Agency Company Limited of 401 Collins Street, Melbourne by the 15th day of November 1977 after which date the Executor will distribute the assets having regard only to the claims of which it then has notice.

PROUDFOOT, HORTON & COOKE, solicitors, 406 Lonsdale Street, Melbourne 323

Creditors next of kin and others having claims in respect of the estate of Jessie Mary Louise Lavery late of 6 Pretoria Street, Balwyn Widow who died on the 27th day of May 1977, are to send their particulars of their claims to the Equity Trustees Executors and Agency Company Limited of 472 Bourke Street, Melbourne by the 29th day of September 1977 after which date it will distribute the assets having regard only to the claims of which it then has notice.

Messrs. W. E. PEARCEY & IVEY, solicitors, 150 Queen Street, Melbourne, 3000 324

BESSIE JEAN YAXLEY, late of Swansea Road, Lilydale, spinster, retired, DECEASED

Creditors, next-of-kin and others having claims in respect of the Estate of the said deceased who died on the 11th July, 1977 are to send particulars of their claims to the Executors of her Will namely Colin Scott McCutcheon and Murray Ross McCutcheon c/- the undermentioned Solicitors at 250 Elizabeth Street Melbourne by the 18th November, 1977 after which date the Executors will distribute the assets in the Estate having regard only to the claims of which they then have notice.

W. B. & O. McCUTCHEON, solicitors, 250 Elizabeth Street, Melbourne 325

ERIC CARDWELL, late of 44 Narong Road, Caulfield, in the State of Victoria, retired tailor, DECEASED, intestate

Creditors, next of kin and others having claims in respect of the Estate of the Deceased (who died on the 4th day of June, 1977) are required by Elizabeth Marjorie Cardwell of 44 Narong Road, Caulfield, the Administratrix to whom Letters of Administration of the Estate of the Deceased have been granted to send particulars of their claims to her Care of Messrs. F. R. E. Dawson & Son, 114 William Street, Melbourne, by the 16th day of November, 1977, after which date she will convey or distribute the assets having regard only to the claims of which she then has notice.

Dated the 14th day of September, 1977

F. R. E. DAWSON & SON, 114 William Street, Melbourne 326

DOROTHY CHARLOTTE HALL, late of 43 Fairview Avenue, Burwood, in the State of Victoria, married woman, DECEASED

Creditors, next of kin and others having claims in respect of the estate of the above named deceased (who died on the 6th day of April 1977) are required to send particulars of their claims to National Trustees Executors and Agency Company of Australasia Limited of 95 Queen Street Melbourne before the 16th day of November 1977 after which date it will distribute the assets of the said deceased having regard only to the claims of which it then has notice of.

PETER HASSETT & CO., solicitors, of 1160 Toorak Road, Hartwell, 3125 327

THE SUNBURY DOWNS WATER SUPPLY COMMITTEE

Creditors and others having claims in respect of the monies standing in a bank account in the name of the above Committee pursuant to an agreement made on the 29th day of June, 1967 between the said Committee of the one part and Sunbury Waterworks Trust of the other part are required by the Trustee James William Thomson and Norma Grace Thomson formerly of Emu Road Sunbury but now of 2 Kingsley Court, Mt. Eliza to send particulars of their claims to the abovementioned Trustees care of the undermentioned Solicitor by the 6th December, 1977 after which date the Trustees regard only to the claims of which they then have notice.

J. R. HOBAN, LL.B., solicitor, of 47 O'Shanassy Street, Sunbury 328

Creditors, next-of-kin and others having claims in respect of the Estate of Trixie May Dalton late of Mon Pax Rest Home, 12 Hanslope Avenue, Alphington, Spinster deceased who died on the eighth day of December, 1976 are to send the particulars of their claims to The Equity Trustees Executors and Agency Company Limited of 472 Bourke Street, Melbourne by the sixteenth day of November, 1977 after which date it will distribute the assets having regard only to the claims of which it then has notice.

FLOOD & PERMEZEL, solicitors, 450 Little Collins Street, Melbourne 331

SOPHIE BOULTON, formerly of 1261 High Street, Malvern, but late of Powell Street, West Ocean Grove, in the State of Victoria, married woman, DECEASED

Creditors next-of-kin and others having claims in respect of the estate of the abovenamed deceased are required by the executor The Trustees Executors and Agency Company Limited of 401 Collins Street Melbourne in the said State to send particulars to the executor by the 23rd day of November, 1977 after which date the executor may convey or distribute the assets having regard only to the claims of which it then has notice.

DAVIES CAMPBELL & PIESSE, solicitors, of 401 Collins Street, Melbourne 332

Creditors next-of-kin and others having claims against the Estate of Gerrit Jan Frederik Staverman late of Mallorca Spain Gentleman deceased who died on 24th October 1976 are requested by the Administrator The Equity Trustees Executors and Agency Company Limited of 472 Bourke Street Melbourne in the State of Victoria the Company duly appointed to act in this matter by the Executor Andrew Albert Osborn appointed in the Will of the said deceased to send particulars of their claims to the said Administrator on or before the 18th November, 1977 after which date the Administrator will distribute the assets having regard only to the claims of which it shall then have had notice.

ELLISON HEWISON & WHITEHEAD, solicitors, 379 Collins Street, Melbourne, 62 2911 333

EVELYN GRACE DE BEER, late of 233 Jasper Road, Benteleigh, in the State of Victoria, widow, DECEASED

Creditors, Next-of-kin and others having claims in respect of the estate of the abovenamed Deceased who died on the 19th April 1977 are required by the Executors Wilma Dawn Oxley married woman and John Graeme Oxley Newsagent both of 96 Exeter Road, North Croydon to send particulars to them by the 10th November, 1977 after which date the Executors intend to convey or distribute the assets of the estate having regard only to the claims of which they may have notice.

TURNER NESS & DAVIS, solicitors, 44 Market Street, Melbourne 334

HENDRICUS FIDELIS MARIA VAN ROOSMALEN, late of 24 Bridport Street, South Melbourne, retired clerk, DECEASED

Creditors next of kin and others having claims in respect of the estate of the deceased who died on 15th April 1977 are required by the executors Roy Clive Hopetoun Beattie of 61 Union Street Armadale Solicitor and Dorothy Helen Scott of 17 Carinya Crescent Caulfield Legal Executive to send particulars thereof to them care of the under-signed Solicitor by 17th November 1977 after which date they may convey or distribute the assets having regard only to the claims of which they then have notice.

R. C. H. BEATTIE, solicitor, 270 Waverley Road, East Malvern 349

FLORENCE ADELE BOULTON, late of Vinifera, in the State of Victoria, retired orchardist, DECEASED (who died on 8th July, 1977)

Creditors next-of-kin and all other persons having claims against the Estate of the deceased are required by the Executors of the Will, Frederick Lawrence Boulton and Lindsay Gordon Boulton, to send particulars to them care of the undersigned on or before the 12th day of December, 1977 after which date they will distribute the assets having regard only to the claims of which they then have notice:

GARDEN & GREEN, solicitors, 4 McCallum Street, Swan Hill 261

Creditors, next of kin, and others having claims in respect of the estate of Alexander John East, late of Emberton, Farmer, deceased, who died on 28th June, 1977, and Probate of whose Will was granted by the Supreme Court of Victoria on 24th August, 1977, to John Graham Bolton, of Kyneton, Solicitor, the sole executor therein named, are required to send particulars of their claims to the said Executor in care of the undersigned Solicitors, before the 14th November, 1977, after which date he will distribute the assets having regard only to the claims of which he shall then have had notice.

PALMER, STEVENS & RENNICK, solicitors, Kyneton 262

Creditors Next of Kin and others having claims in respect of the estate of Alexandra Clarendia May Alomes late of Yarra Street Yarra Junction in the State of Victoria. Widow deceased who died on the 23rd of April 1977 are required to send particulars of their claims to the Equity Trustees Executors and Agency Company Limited of 472 Bourke Street Melbourne on or before the 22nd of November 1977 after which date it will distribute the assets, having regard only to the claims of which it then has notice.

PRENDERGAST, O'SULLIVAN & HENNESSY, solicitors, of 150 Queen Street, Melbourne 350

Creditors, next of kin and those having claims in respect of the Estate of Rex Rattray Deans late of 57 Denys Street Fawkner in the State of Victoria Electrical Mechanic deceased who died on the Twenty-fifth day of July 1976 are required by the Executrix of the Estate Valerie Margaret Deans of 57 Denys Street Fawkner in the said State Widow to send particulars to N. C. Gay & Co., Solicitors of 136 Sydney Road, Brunswick, by the 30th day of November, 1977 after which date the said Executrix may distribute the assets having regard only to claims of which she then has notice.

N. C. GAY & CO., solicitors, 136 Sydney Road, Brunswick 356

EDITH MABEL CROSS, late of 268 St. Georges Road, Northcote, widow, DECEASED

Creditors, next of kin and others having claims in respect of the estate of the deceased (who died on the 1st day of August, 1977) are required to send particulars of their claims to Norman Ernest Cross, care of F. P. & M. J. Walsh, Solicitors of 452 High Street, Northcote before the 23rd day of November, 1977 after which date he will distribute the assets having regard only to the claims of which he then has notice.

F. P. & M. J. WALSH, solicitors, 452 High Street, Northcote 357

ELSIE GLADYS LOVETT, late of 218 Noone Street, Clifton Hill, widow, DECEASED

Creditors next of kin and others having claims in respect of the estate of the deceased (who died on the 1st day of April, 1977) are required to send particulars of their claims to Richard James Lovett, care of F. P. & M. J. Walsh, Solicitors of 452 High Street, Northcote before the 23rd day of November, 1977 after which date he will distribute the assets having regard only to the claims of which he then has notice.

F. P. & M. J. WALSH, solicitors, 452 High Street, Northcote 358

Creditors next of kin and others having claims in respect of the estate of Mary Veronica Fahey late of 339 Barkly Street Elwood in the State of Victoria Widow deceased who died on the 8th day of March 1977 are required by the Executor National Trustees Executors and Agency Company of Australasia Limited, of 95 Queen Street Melbourne to send particulars of their claims in writing in the care of the said Company prior to the 14th November 1977 after which date the said Executor will distribute the assets having regard only to the claims of which it then shall have had notice.

ROGERS & GAYLARD, solicitors, 51 Queen Street, Melbourne 373

Creditors next of kin and others having claims in respect of the estate of Claude Samuel John O'Brien formerly of 52 Barkly Street, St. Kilda but late of Anzac Hostel, North Road, Brighton Gentleman who died on the 14th June 1977 are to send particulars of their claims to the Executor William Dunstan Thompson care of the undersigned by the 23rd November 1977 after which date he will commence to distribute the assets having regard only to the claims of which he then has notice.

RENNICK & GAYNOR, solicitors, 427 Riversdale Road, Hawthorn East 374

Creditors Next of Kin and others having claims in respect of the Estate of Annie Clinton late of 40 Avondale Road; Preston Widow Deceased who died on the 14th February, 1947 are requested to send particulars of their claims to the Executor Michael Joseph Mornane of 118 Queen Street, Melbourne Solicitor by the 17th November, 1977 after which date he will distribute the assets having regard only to the claims of which he shall then have had notice:

M. MORNANE, solicitor, 118 Queen Street, Melbourne 375

THOMAS JENNINGS, late of 6 Hollsmoor Road, Burwood, retired engineer, DECEASED

Creditors next of kin and others having claims against the Estate of the said deceased who died on 2nd February 1977 are to send particulars of their claims to Margaret Christine Crook C/- Blake & Riggall 140 William Street Melbourne by the 16th day of November 1977 after which date she will distribute the assets having regard only to the claims of which she then has notice.

BLAKE & RIGGALL, solicitors, 140 William Street, Melbourne 376

BRENDA SLEIGH, late of 42 Wallace Avenue, Toorak, married woman, DECEASED

Creditors next of kin and others having claims against the Estate of the said deceased who died on 13th December 1976 are to send particulars of their claims to Peter James Dodds, Simon Winter Dodds and James Grimaldi Perry C/- Blake & Riggall 140 William Street Melbourne by the 16th day of November 1977 after which date they will distribute the assets having regard only to the claims of which they then have notice.

BLAKE & RIGGALL, solicitors, 140 William Street, Melbourne 377

Trustee Act 1958

NOTICE TO CLAIMANTS

Pursuant to the Trustee Act 1958, creditors next of kin and all other persons having claims in respect of the estate of any deceased person named below are required to send particulars to the legal personal representative or representatives at the addresses stated, after which date the representatives will distribute the assets, having regard only to the claims of which notice has been received:—

John Lawrence Gorry late of the Little Sisters of the Poor, St. George's Road Northcote Catholic Priest deceased, died on the 18th day of May 1977. Claims to the Executors National Trustees Executors and Agency Company of Australasia Limited of 95 Queen Street Melbourne and George Maher of 118 New Street Brighton, at the aforesaid address of National Trustees Executors and Agency Company of Australasia Limited by the 21st day of November, 1977.—JOHN F. CARROLL, LL.B., solicitor, 4 Paisley Street, Footscray. 348

In the Supreme Court of the State of Victoria
SALE BY THE SHERIFF

On Friday the 21st of October 1977 at 10.30 a.m. at the Police Station Chelsea (unless process be stayed or satisfied).

All the Estate and Interest (if any) of Alfred Frank Kefford, clerk, of 6 Swansea Road, Chelsea as proprietor of an estate in fee simple in the land described in Certificate of Title Volume 3752 Folio 373 upon which is erected a dwelling known as No. 6 Swansea Road Chelsea.

Registered Mortgages Nos. C.916957 and F.401381 affect the said estate and interest.

Terms—Cash only

380 DOUGLAS S. HALL, Sheriff's Officer

In the Supreme Court of the State of Victoria
SALE BY THE SHERIFF

On Friday the 28th of October 1977 at 1.50 p.m. at the Police Station Mount Waverley (unless process be stayed or satisfied).

All the Estate and Interest (if any) of John Edwy Wettenhall, cartage contractor, of 58-60 Ian Grove, East Oakleigh as proprietor of an estate in fee simple in the land described in Certificate of Title Volume 8985 Folio 374 upon which is erected a fenced truck depot with weighbridge known as No. 22-24 Commercial Road North Clayton.

Registered Mortgages No. G.547308 and G.547309 and Caveat G.510489 affect the said estate and interest.

Terms—Cash only

381 H. BUETTNER, Sheriff's Officer

In the Supreme Court of the State of Victoria
SALE BY THE SHERIFF

On Friday the 28th of October 1977 at 1.40 p.m. at the Police Station Mount Waverley (unless process be stayed or satisfied).

All the Estate and Interest (if any) of John Edwy Wettenhall, cartage contractor, of 58-60 Ian Grove, East Oakleigh as joint proprietor with June Dehlia Wettenhall, married woman of an estate in fee simple in the land described in Certificate of Title Volume 8532 Folio 605 upon which is erected a swimming pool and garden known as No. 58-60 Ian Grove East Oakleigh.

Registered Mortgages Nos. C.498315 and C.611457 affect the said estate and interest.

Terms—Cash only

382 H. BUETTNER, Sheriff's Officer

In the Supreme Court of the State of Victoria
SALE BY THE SHERIFF

On Friday the 28th of October 1977 at 1.30 p.m. at the Police Station Mount Waverley (unless process be stayed or satisfied).

All the Estate and Interest (if any) of John Edwy Wettenhall, cartage contractor, of 58-60 Ian Grove, East Oakleigh as proprietor of an estate in fee simple in the land described in Certificate of Title Volume 8532 Folio 604 upon which is erected a brick veneer dwelling known as No. 58-60 Ian Grove East Oakleigh.

Registered Mortgages Nos. D.854560 and E.614022 and Caveat F.773725 affect the said estate and interest.

Terms—Cash only

383 H. BUETTNER, Sheriff's Officer

In the Supreme Court of the State of Victoria
SALE BY THE SHERIFF

On Friday the 28th of October 1977 at 10.30 a.m. at the Police Station Alexandra (unless process be stayed or satisfied).

All the Estate and Interest (if any) of John Edwy Wettenhall, cartage contractor, of 58-60 Ian Grove, East Oakleigh as proprietor of an estate in fee simple in the land described in Certificate of Title Volume 8020 Folio 160 upon which is erected a partly completed large dwelling known as Cnr. Maroondah Highway and Government Road, Taggerty.

Registered Mortgages Nos. G.547308, G.547309 and Caveat G.510489 affect the said estate and interest.

Terms—Cash only

384 H. BUETTNER, Sheriff's Officer

No. 76—8910/77—4

In the Supreme Court of the State of Victoria
SALE BY THE SHERIFF

On Friday the 21st of October 1977 at 10.30 a.m. at the Police Station Ringwood (unless process be stayed or satisfied).

All the Estate and Interest (if any) of Mrs. C. Kusack (shown on Certificate of Title as Carmen Kusack) advertising representative, of 24 Chartwell Drive, Wantirna as proprietor of an estate in fee simple in the land described in Certificate of Title Volume 8994 Folio 368 upon which is erected a brick dwelling known as No. 24 Chartwell Drive Wantirna.

Registered Mortgage No. F.909173 and Caveats G.102692, G.150441, G.497286 and G.538243 affect the said estate and interest.

Terms—Cash only

342 H. BUETTNER, Sheriff's Officer

In the Supreme Court of the State of Victoria
SALE BY THE SHERIFF

On Friday the 21st of October 1977 at 2.30 p.m. at the Police Station Burwood (unless process be stayed or satisfied).

All the Estate and Interest (if any) of Mr. John Ronald Sanderson, accountant, of 12 Robert Street, East Burwood as joint proprietor with Mary Jane Sanderson of an estate in fee simple in the land described in Certificate of Title Volume 8310 Folio 659 upon which is erected a brick veneer dwelling known as No. 12 Robert Street East Burwood.

Registered Mortgage No. C.188128 affects the said estate and interest.

Terms—Cash only

343 H. BUETTNER, Sheriff's Officer

In the Supreme Court of the State of Victoria
SALE BY THE SHERIFF

On Friday the 21st of October 1977 at 2.30 p.m. at the Police Station Richmond (unless process be stayed or satisfied).

All the Estate and Interest (if any) of Gerassimos Paizis, P.M.G. driver, of 44 Mary Street, Richmond as proprietor of an estate in fee simple in the land described in Certificate of Title Volume 5875 Folio 820 upon which is erected a solid brick dwelling known as No. 44 Mary Street Richmond.

Registered Mortgage No. F.927999 and Caveat F.198314 affect the said estate and interest.

Terms—Cash only

344 H. BUETTNER, Sheriff's Officer

IMPOUNDING

HEALESVILLE—Impounded in Healesville Pound.

1 Shorthorn crossbred bull

If not claimed and expenses paid to be sold by public auction on Thursday, 29th September, 1977, at 12 noon.

354—\$3.30 E. PULLEN,
Poundkeeper

Subordinate Legislation Act 1962

NOTICE OF MAKING OF STATUTORY RULES

In pursuance of the provisions of the *Subordinate Legislation Act 1962* and the Regulations made thereunder, notice is given of the making of the following statutory rules:—

No.	Public Trustee Act 1958	Price
254/1977.	Agents of the Public Trustee (Revocation) Regulations 1977	10c
<i>Hospitals Superannuation Act 1965</i>		
255/1977.	Hospitals Superannuation (Board Amendment) Regulations 1977	10c
<i>Supreme Court Act 1958</i>		
256/1977.	Supreme Court (Court Fees) Regulations 1977	20c

<i>Vegetation and Vine Diseases Act 1958</i>	
257/1977. Vegetation and Vine Diseases (Fees) Regulations 1977 ..	10c
<i>Seeds Act 1971</i>	
258/1977. Seeds (Fees) Regulations 1977 ..	10c
<i>Milk and Dairy Supervision Act 1958</i>	
259/1977. Milk and Dairy Supervision (Fees) Regulations 1977 ..	10c
<i>Aerial Spraying Control Act 1966</i>	
260/1977. Aerial Spraying Control (Fees) Regulations 1977 ..	10c
<i>Abattoir and Meat Inspection Act 1973</i>	
261/1977. Abattoir and Meat Inspection (Fees) Regulations 1977 ..	10c
<i>Stock Diseases Act 1968</i>	
262/1977. Stock Diseases (Fees) Regulations 1977 ..	10c
<i>Dairy Products Act 1958</i>	
263/1977. Dairy Products (Victorian Dairy Products Board Fees) Regulations 1977 ..	10c
<i>Stock Medicines Act 1958</i>	
264/1977. Stock Medicines (Amendment) Regulations 1977 ..	10c
<i>Milk Pasteurization Act 1958</i>	
265/1977. Milk Pasteurization Committee (Remuneration) Regulations 1977 ..	10c
<i>Farm Produce Merchants and Commission Agents Act 1965</i>	
266/1977. Farm Produce Merchants and Commission Agents (Disputes Committee Fees) Regulations 1977 ..	10c
<i>Milk and Dairy Supervision Act 1958</i>	
267/1977. Milk and Dairy Supervision (Dairy Produce Board Remuneration) Regulations 1977 ..	10c
<i>Stock Medicines Act 1958</i>	
268/1977. Stock Medicines (Fees) Regulations 1977 ..	10c
<i>Fertilizers Act 1974</i>	
269/1977. Fertilizers (Fees) Regulations 1977 ..	10c
<i>Pesticides Act 1958</i>	
270/1977. Pesticides (Fees) Regulations 1977 ..	10c
<i>Abattoir and Meat Inspection Act 1973</i>	
271/1977. Abattoir and Meat Inspection (Knackereries and Pet Food Establishments) (Fees) Regulations 1977 ..	10c
<i>Industrial Training Act 1975</i>	
272/1977. Industrial Training (Footwear Trades Apprenticeship) Regulations 1977 ..	30c
<i>Industrial Training Act 1975</i>	
273/1977. Industrial Training (Horticultural Trades Apprenticeship) Regulations 1977 ..	20c
<i>Forests Act 1958</i>	
274/1977. Forests (Lake McCall-Say Reserve) Regulations 1977 ..	10c
<i>Education Act 1958</i>	
275/1977. Education Department (Amendment) Regulations 1977 (Amendment No. 45) ..	30c
<i>Strata Titles Act 1967</i>	
276/1977. Strata Titles (Fees) Regulations 1977 ..	10c
<i>Religious Successory and Charitable Trusts Act 1958</i>	
277/1977. Religious Successory and Charitable Trusts Act (Fees) Rules 1977 ..	10c
<i>Public Service Act 1974</i>	
PSD85/1977. Public Service Determinations ..	10c
PSD86/1977. Public Service Determinations ..	10c
PSD87/1977. Public Service Determinations ..	10c

Copies of these statutory rules may be purchased at the Sale of Publications Section of the Government Printing Office, located at 7A Parliament Place, Melbourne, 3002. If ordered by mail, remittance should be addressed to "The Government Printer, Box 203, P.O., North Melbourne, 3051", and should include 20c extra for postage.

The annual subscription rates for Statutory Rules for the year commencing 1st January, 1976, payable in advance, are as follows:—

Statutory Rules (other than Public Service Determinations) ..	\$45.00
Public Service Determinations ..	\$20.00

F. D. ATKINSON,
Government Printer

STATE ACTS, 1975

Copies of the following Acts of the Parliament of Victoria may be obtained at the Government Printing Office, Sale of Publications Branch, 7A Parliament Place, Melbourne, Phone 651 2754 or 651 2759, or from any accredited agent, at the price set opposite to each (these prices do not include postage).

Postage costs must be added to your remittance when ordering by mail as follows:—

Act Price	Postage Cost
10c-40c ..	20c
45c-70c ..	30c
75c-\$1.70 ..	40c
\$1.75-\$4.00 ..	60c
Above \$4.00 ..	86c

Bound Volumes are also available at a cost of \$24.50.

No.	Price
8663. Parliamentary Salaries and Superannuation (Amendment) ..	\$0.15
8664. Dog (Amendment) ..	\$0.10
8665. State College of Victoria (Borrowing Powers) ..	\$0.10
8666. Scaffolding (Amendment) ..	\$0.10
8667. Marine (Amendment) ..	\$0.10
8668. Methodist Church of Australasia Superannumerary Ministers and Ministers' Widows Fund ..	\$0.10
8669. Motor Accidents ..	\$0.10
8670. Pensioners' Rates Remission ..	\$0.10
8671. Geelong Harbor Trust Lands ..	\$0.15
8672. Railways (Amendment) ..	\$0.15
8673. Labour and Industry (Industrial Appeals Court) ..	\$0.10
8674. Health (Proprietary Medicines Advisory Committee) ..	\$0.10
8675. William E. Dorling Scholarship Fund ..	\$0.10
8676. Transport Regulation (Licence Fees) ..	\$0.10
8677. Juries (Amendment) ..	\$0.10
8678. Northcote Trust Fund ..	\$0.15
8679. Crimes (Capital Offences) ..	\$0.10
8680. Judges Salaries and Allowances ..	\$0.10
8681. Stock Foods ..	\$0.10
8682. Heathcote Railway Removal ..	\$0.15
8683. Home Finance (Amendment) ..	\$0.10
8684. Building Societies (Special Advances) ..	\$0.10
8685. Melbourne (Snowden Gardens) Land ..	\$0.10
8686. Thornbury Lands ..	\$0.15
8687. Parliamentary Salaries and Superannuation ..	\$0.10
8688. Water (Amendment) ..	\$0.30
8689. Veterinary Surgeons (Amendment) ..	\$0.10
8690. Racing ..	\$0.10
8691. Teaching Service (Assistant Professional Appointees) ..	\$0.10
8692. Public Service (Transitional Provisions) ..	\$0.10
8693. Building Industry Long Service Leave ..	\$0.40
8694. Fisheries ..	\$0.30
8695. Local Government (City of Ringwood) ..	\$0.10
8696. Hairdressers Legislation (Amendment) ..	\$0.10
8697. Professional Boxing Control ..	\$0.15
8698. Trustee Companies (Commission) ..	\$0.10
8699. Wildlife ..	\$0.50
8700. Transport Regulation (Private Omnibuses) ..	\$0.10
8701. Social Welfare (Amendment) ..	\$0.20
8702. National Parks ..	\$0.50
8703. Carlton (Recreation Ground) Land ..	\$0.10
8704. Broiler Chicken Industry ..	\$0.15
8705. Stock Diseases (Amendment) ..	\$0.10
8706. Industrial Training ..	\$0.50
8707. Town and Country Planning (Amendment) ..	\$0.10
8708. Dandenong Valley Authority (Amendment) ..	\$0.10

STATE ACTS, 1975—continued

No.	Price
8709. Stock (Artificial Breeding) (Amendment)	\$0.10
8710. Victoria Institute of Colleges (Amendment)	\$0.10
8711. Latrobe Valley (Amendment)	\$0.10
8712. Geelong Waterworks and Sewerage (Powers)	\$0.10
8713. Housing (Movable Units)	\$0.10
8714. Cattle Compensation (Amendment)	\$0.10
8715. Stock Medicines (Amendment)	\$0.10
8716. Town and Country Planning (Outdoor Advertising)	\$0.30
8717. Superannuation	\$0.50
8718. Magistrates' Courts (Amendment)	\$0.15
8719. Gas and Fuel Corporation	\$0.10
8720. Margarine	\$0.30
8721. Teaching Service (Special Duty Allowances)	\$0.10
8722. Police Regulation (Pensions)	\$0.20
8723. Marine (Further Amendment)	\$0.30
8724. Ports and Harbors	\$0.15
8725. Tomato Processing Industry (Uniform Agreement) (Amendment)	\$0.15
8726. Grain Elevators (Amendment)	\$0.10
8727. State Insurance Office	\$0.30
8728. Supply (1975-76, No. 1)	\$0.15
8729. Water Resources	\$0.15
8730. Parliamentary Officers	\$0.15
8731. Magistrates (Summary Proceedings)	\$1.50
8732. Liquor Control (Amendment)	\$0.30
8733. Workers Compensation (Amendment)	\$0.30
8734. Small Claims Tribunals (Amendment)	\$0.10
8735. Eltham Land	\$0.10
8736. Frankston Land	\$0.10
8737. Melbourne Cricket Ground (Amendment)	\$0.10
8738. South Melbourne Land	\$0.10
8739. Racing (Totalizer)	\$0.10
8740. Land Settlement (Amendment)	\$0.10
8741. Rural Finance (Amendment)	\$0.10
8742. Water Resources (Amendment)	\$0.10
8743. Nurses (Amendment)	\$0.10
8744. Lifts and Cranes (Amendment)	\$0.10
8745. Police Regulation (Amendment)	\$0.10
8746. Business Franchise (Tobacco)	\$0.10
8747. Stamps	\$0.10
8748. Forests (Softwood Holdings Agreement)	\$0.20
8749. Harbors and Navigable Waters Protection	\$0.30
8750. Constitution	\$0.50
8751. Decentralized Industries Incentive Payments (Amendment)	\$0.10
8752. Courts Administration	\$0.10
8753. Metropolitan Fire Brigades (Borrowing Powers)	\$0.10
8754. Medical Practitioners (Fees)	\$0.10
8755. Lotteries Gaming and Betting (Amendment)	\$0.10
8756. Health (Fees)	\$0.10
8757. Coal Creek Historical Park	\$0.30
8758. Melbourne Harbor Trust (Long Service Leave) (Amendment)	\$0.10
8759. Police Regulation (Long Service Leave)	\$0.10
8760. Metropolitan Fire Brigades (Long Service Leave)	\$0.10
8761. Liquor Control (Chairmen)	\$0.10
8762. Bendigo (Dai Gum San Village) Land	\$0.10
8763. Land	\$0.10
8764. Wodonga Area Land Acquisition (Amendment)	\$0.10
8765. Road Traffic (Amendment)	\$0.20
8766. Education (Work Experience) (Amendment)	\$0.10
8767. Agricultural Colleges (Amendment)	\$0.20
8768. Education (Administration)	\$0.10
8769. Inflammable Liquids (Amendment)	\$0.10
8770. Land Tax	\$0.10
8771. Superannuation (Amendment)	\$0.10
8772. Patriotic Funds (Amendment)	\$0.10
8773. Horse Breeding (Repeal)	\$0.10
8774. Milk and Dairy Supervision (Amendment)	\$0.10
8775. Stock Diseases (Further Amendment)	\$0.10
8776. Racing (Mid-week Racing)	\$0.20
8777. State Forests Works and Services	\$0.10
8778. Legal Profession Practice	\$0.10
8779. Public Works and Services	\$0.20
8780. Appropriation (1975-76, No. 1)	\$3.10
8781. Local Government (Amendment)	\$0.80
8782. Zoological Gardens (Amendment)	\$0.20
8783. Education (Volunteer Workers Compensation)	\$0.10
8784. State Development (Amendment)	\$0.10
8785. Pay-roll Tax	\$0.50
8786. Co-operative Housing Societies (Amendment)	\$0.10
8787. Companies	\$1.50
8788. Securities Industry	\$1.50
8789. Teaching Service (Amendment)	\$0.20
8790. Educational Grants (Continuation)	\$0.10
8791. Coal Mines (Pensions Increase)	\$0.10
8792. Motor Car (Penalties)	\$0.20

STATE ACTS 1975—continued

No.	Price
8793. State Co-ordination Council	\$0.20
8794. Pensioners' Water and Sewerage Rates Remission	\$0.30
8795. Revocation and Excision of Crown Reservations	\$0.10
8796. Ports and Harbors (Penalties)	\$0.20
8797. State Electricity Commission (Amendment)	\$0.10
8798. The Constitution Act Amendment (Conjoint Elections)	\$0.10
8799. Education (School Councils)	\$0.20
8800. Optometrists	\$0.30
8801. Railways (Amendment)	\$0.10
8802. Scaffolding (Amendment)	\$0.10
8803. Transport Works and Services	\$0.10
8804. Workers Compensation (Surcharge Payments)	\$0.10
8805. Mines (Amendment)	\$0.30
8806. Public Service	\$0.10
8807. State Electricity Commission (Tramways)	\$0.10
8808. Dental Technicians (Amendment)	\$0.10
8809. Melbourne Underground Rail Loop (Amendment)	\$0.10
8810. Motor Car (Child Seat Restraints)	\$0.10
8811. Drainage of Land	\$0.80
8812. Railways (Participation in Pipeline Operation)	\$0.10
8813. Country Fire Authority (Constitution)	\$0.10
8814. Labour and Industry (Wages Board Determinations)	\$0.10
8815. West Moorabool Water Board (Amendment)	\$0.10
8816. Navigable Waters (Oil Pollution) (Amendment)	\$0.10
8817. Valuation of Land (Amendment)	\$0.10
8818. Town and Country Planning (Further Amendment)	\$0.10
8819. Local Authorities Superannuation (Pensions)	\$0.40
8820. Latrobe University (Amendment)	\$0.10
8821. Social Welfare (Amendment)	\$0.10
8822. Geelong Regional Authority	\$0.60
8823. Environment Protection (Noise Control)	\$0.30
8824. Consumer Affairs (Amendment)	\$0.10
8825. Water Supply Works and Services	\$0.40

STATE ACTS, 1976

Copies of the following Acts of the Parliament of Victoria may be obtained at the Government Printing Office, Sale of Publications Branch, 7A Parliament Place, Melbourne, phone 651 2754 or 651 2759, or from any accredited agent, at the price set opposite to each (these prices do not include postage).

Postage costs must be added to your remittance when ordering by mail as follows:—

Act Price	Postage Cost
10c-40c	20c
45c-70c	30c
75c-\$1.70	40c
\$1.75-\$4.00	60c
Above \$4.00	86c

Bound Volumes of 1975 State Acts are also available at a cost of \$24.50.

No.	PRICE
8826. Public Servants Ethical Conduct (Joint Select Committee)	\$0.10
8827. Committees (Membership)	\$0.10
8828. Joint Select Committee (Meat Industry)	\$0.10
8829. Joint Select Committee (Road Safety)	\$0.10
8830. Latrobe Valley (Manager's Qualifications)	\$0.10
8831. Ministry for the Arts (Transfer of Administration)	\$0.10
8832. Bendigo College of Advanced Education	\$0.10
8833. Ballarat College of Advanced Education	\$0.20
8834. Constitution (Responsible Ministers)	\$0.10
8835. Bees (Amendment)	\$0.10
8836. Australian Tractor Testing Station	\$0.10
8837. Liquefied Gases (Amendment)	\$0.30
8838. Business Franchise (Tobacco)	\$0.30
8839. Land (Surrender of Lands)	\$0.10
8840. Dandenong (Shepley Oval) Land	\$0.10
8841. Railways (Participation in Pipeline Operations Payments)	\$0.10
8842. Tattersall Consultations (Soccer Football Pools)	\$0.10
8843. Commonwealth and States Financial Agreement	\$0.30
8844. Trustee Companies (Union-Fidelity) Amendment	\$0.10

STATE ACTS, 1976—continued.	
No.	Price
8845.	Supply (1976-77, No. 1) .. \$0.20
8846.	National Gallery of Victoria (Development Collection) .. \$0.10
8847.	Revocation and Excision of Crown Reservations .. \$0.20
8848.	Pesticides (Amendment) .. \$0.10
8849.	Architects (Amendment) .. \$0.10
8850.	Gippsland Folk Museum .. \$0.40
8851.	Joint Select Committee (Conservation of Energy Resources) .. \$0.10
8852.	Tomato Processing Industry .. \$0.50
8853.	Judges Salaries .. \$0.10
8854.	Small Business Development Corporation .. \$0.20
8855.	Home Finance (Loans and Guarantees) .. \$0.10
8856.	Teaching Service (Professional Appointments) .. \$0.10
8857.	Friendly Societies (Amendment) .. \$0.10
8858.	Public Works and Services (Further Expenditure) .. \$0.10
8859.	Sewerage Districts (Amendment) .. \$0.20
8860.	Mildura College Lands (Schools Fund) .. \$0.10
8861.	Dandenong Valley Authority (Amendment) .. \$0.10
8862.	Second-hand Dealers (Charity Collectors) .. \$0.30
8863.	Mental Health (Amendment) .. \$0.10
8864.	Victorian Film Corporation .. \$0.20
8865.	Motor Car (Breath Testing Stations) .. \$0.10
8866.	Education (Minister of Special Education) .. \$0.10
8867.	Deakin University (Amendment) .. \$0.10
8868.	Public Service (Long Service Leave) .. \$0.10
8869.	Victorian Development Corporation .. \$0.10
8870.	Crimes .. \$0.30
8871.	Weights and Measures (Amendment) .. \$0.30
8872.	Wild Flowers and Native Plants Protection (Amendment) .. \$0.10
8873.	Ministry of Transport (Amendment) .. \$0.10
8874.	Abattoir and Meat Inspection (Amendment) .. \$0.30
8875.	Local Government (Rates) Amendment .. \$0.20
8876.	Cluster Titles (Amendment) .. \$0.10
8877.	Parliamentary Allowances .. \$0.10
8878.	Liquor Control (Exhibition Buildings) .. \$0.10
8879.	Waterworks Trusts Association of Victoria (Financial Year) .. \$0.10
8880.	Provincial Sewerage Authorities Association of Victoria (Financial Year) .. \$0.10
8881.	Crown Reservations (Revocations and Excisions) .. \$0.30
8882.	Co-operative Housing Societies (Amendment) .. \$0.10
8883.	County Court (Amendment) .. \$0.10
8884.	Ombudsman (Municipalities) .. \$0.10
8885.	Racing (Amendment) .. \$0.10
8886.	Home Finance (Amendment) .. \$0.10
8887.	Victoria Grants Commission .. \$0.20
8888.	Local Government (City of Sunshine) .. \$0.20
8889.	Gordon Technical College .. \$0.20
8890.	Water (Amendment) .. \$0.20
8891.	Nar Nar Goon Land Exchange .. \$0.10
8892.	Forests (Advances) .. \$0.10
8893.	Pensioners' Rates Remission .. \$0.40
8894.	State Electricity Commission (Loy Yang Power Station) .. \$0.10
8895.	Appropriation (1976-77, No. 1) .. \$3.10
8896.	Vital State Projects .. \$0.20
8897.	Barley Marketing (Amendment) .. \$0.10
8898.	Labour and Industry (Amendment) .. \$0.10
8899.	Lands Compensation (Amendment) .. \$0.10
8900.	Dentists (Amendment) .. \$0.30
8901.	Educational Institutions (Guarantees) .. \$0.10
8902.	Appeal Costs Fund (Amendment) .. \$0.10
8903.	Co-operation (Amendment) .. \$0.20
8904.	Victorian Institute of Secondary Education .. \$0.20
8905.	Water Supply Works and Services .. \$0.40
8906.	Health (Fees) .. \$0.10
8907.	Cemeteries (Amendment) .. \$0.10
8908.	State Forests Works and Services .. \$0.10
8909.	Gold Buyers (Repeal) .. \$0.10
8910.	Melbourne and Metropolitan Tramways (East Burwood Tramway) .. \$0.10
8911.	Box Hill Land .. \$0.20
8912.	Liquor Control (Orderly Marketing) .. \$0.10
8913.	Melbourne Underground Rail Loop (Financial Contributions) .. \$0.10
8914.	Companies (Fees) .. \$0.10
8915.	Employers and Employés (Repeal) .. \$0.10
8916.	Gas and Fuel Corporation (Borrowing Powers) .. \$0.10
8917.	Teacher Housing (Amendment) .. \$0.10
8918.	Education (Special Developmental Schools) .. \$0.10
8919.	Coal Mines (Pensions) .. \$0.10
8920.	Mines .. \$0.10
8921.	Northcote Children's Home .. \$0.10
8922.	Victoria Racing Club (Borrowings) .. \$0.10
8923.	Taxation Appeals (Amendment) .. \$0.10
8924.	Marine (Amendment) .. \$0.30

STATE ACTS, 1976—continued	
No.	PRICE
8925.	Hospitals Superannuation (Amendment) .. \$0.50
8926.	Ports and Harbours .. \$0.20
8927.	Building Industry Long Service Leave (Amendment) .. \$0.20
8928.	Public Works and Services .. \$0.20
8929.	Public Service (Amendment) .. \$0.10
8930.	Educational Grants (Continuation) .. \$0.10
8931.	Transport Works and Services .. \$0.10
8932.	Housing (Amendment) .. \$0.20
8933.	Country Fire Authority (Amendment) .. \$0.10
8934.	Psychological Practices (Psychologists' Qualifications) .. \$0.10
8935.	Dietitians Registration (Fees) .. \$0.10
8936.	Probate Duty .. \$0.10
8937.	Wodonga Area Land Acquisition (Amendment) .. \$0.10
8938.	Building Contracts (Deposits) (Amendment) .. \$0.10
8939.	Railways (Penalties) .. \$0.10
8940.	River Improvement (United Districts) .. \$0.10
8941.	Mildura Irrigation and Water Trusts (Amendment) .. \$0.20
8942.	Magistrates' Courts (Amendment) .. \$0.10
8943.	Melbourne and Metropolitan Board of Works (Municipalities Contributions) .. \$0.10
8944.	Acts Interpretation (Amendment) .. \$0.10
8945.	Forests (Fire Prevention and Protection) (Amendment) .. \$0.10
8946.	Land Tax .. \$0.10
8947.	Shearers Accommodation .. \$0.20
8948.	Liquor Control (Fees) .. \$0.10
8949.	Pay-roll Tax .. \$0.20
8950.	Rape Offences (Proceedings) .. \$0.20
8951.	Supreme Court .. \$0.40
8952.	Metropolitan Fire Brigades Superannuation .. \$0.50
8953.	Minerals and Energy .. \$0.10
8954.	Legal Profession Practice (Guarantee Fund) .. \$0.20
8955.	Magistrates (Summary Proceedings) (Amendment) .. \$0.10
8956.	Money Lenders (Credit Societies) .. \$0.10
8957.	Patriotic Funds (Amendment) .. \$0.10
8958.	Local Government (House Builders' Liability) .. \$0.30
8959.	Police Regulation (Long Service Leave) .. \$0.10
8960.	Private Agents (Amendment) .. \$0.20
8961.	Poisons (Drugs of Addiction) .. \$0.20
8962.	Constitution (Validation of Elections) .. \$0.10
8963.	Ministry of Immigration and Ethnic Affairs .. \$0.10
8964.	Motor Car (Fees) .. \$0.10
8965.	Marketing of Primary Products (Marketing Boards) .. \$0.30
8966.	Building Societies .. \$1.40
8967.	Water and Sewerage Authorities (Accident Insurance and Employés Long Service Leave) .. \$1.30
8968.	Upper Yarra Valley and Dandenong Ranges Authority .. \$0.80

STATE ACTS, 1977

Copies of the following Acts of the Parliament of Victoria may be obtained at the Government Printing Office, Sale of Publications Branch, 7A Parliament Place, Melbourne, phone 651 2754 or 651 2759, or from any accredited agent, at the price set opposite to each (these prices do not include postage).

Postage costs must be added to your remittance when ordering by mail as follows:—

Act Price.	Postage Cost.
10c-40c	20c
45c-70c	30c
75c-\$1.70	40c
\$1.75-\$4.00	60c
Above \$4.00	86c

No.	PRICE.
8969.	Small Claims Tribunals (Amendment) .. \$0.10
8970.	Local Government (Rate Relief) .. \$0.10
8971.	State Electricity Commission (Financial Accommodation) .. \$0.10
8972.	Geelong (Kardinia Park) Land .. \$0.10
8973.	Revocation and Excision of Crown Reservations .. \$0.30
8974.	Agricultural Authorities (Members Insurance) .. \$0.10
8975.	Racing (Tabella Totalizators) .. \$0.30
8976.	Fuel Emergency .. \$0.20
8977.	Australia and New Zealand Banking Group .. \$0.20

STATE ACTS, 1977—continued.

No.	Price.
8978. Co-operative Housing Societies (Leasehold Securities)	\$0.10
8979. Geelong Waterworks and Sewerage (Amendment)	\$0.20
8980. Yooralla Society of Victoria	\$0.10
8981. Melbourne Underground Rail Loop (Amendment)	\$0.20
8982. Tattersall Consultations (Gold Lottery Consultations)	\$0.10
8983. Public Service (Government Offices)	\$0.10
8984. Anglican Church of Australia Constitution (Amendment)	\$0.20
8985. Portland Harbor Trust (Financial)	\$0.10
8986. Epworth Hospital (Guarantee)	\$0.10
8987. Mildura College Lands (Mildura Schools Fund)	\$0.10
8988. Lotteries Gaming and Betting (Raffles and Bingo)	\$0.40
8989. Racing (Amendment)	\$0.10
8990. Land Surveyors (Surveyors Board)	\$0.10
8991. Railways (Participation in Pipelines)	\$0.10
8992. Melbourne and Metropolitan Tramways (Borrowing Powers)	\$0.10
8993. Melbourne Wholesale Fruit and Vegetable Market Trust	\$0.80
8994. Geelong Grammar Schools Amalgamations	\$0.50
8995. Melton Land	\$0.10
8996. Land (Surrender of Lands)	\$0.10
8997. Shepparton Abattoirs (Amendment)	\$0.10
8998. Magistrates' Courts (Commitment)	\$0.10
8999. Melbourne and Geelong Corporations (Regent Theatre Buildings)	\$0.10
9000. Dental Technicians (Amendment)	\$0.10
9001. Motor Car (Breath Testing Stations) (Amendment)	\$0.10
9002. Marriage (Amendment)	\$0.10
9003. Public Contracts (Amendment)	\$0.10
9004. Victorian Dairy Industry Authority	\$0.60
9005. Public Service (Director-General of Agriculture)	\$0.20
9006. Local Authorities Superannuation (Contributions)	\$0.20
9007. County Court (Amendment)	\$0.10
9008. Bail	\$0.60
9009. Supply (1977-78, No. 1)	\$0.20
9010. Grain Elevators (Amendment)	\$0.30
9011. State Electricity Commission (Newport Power Station)	\$0.10
9012. Police Offences (Child Pornography)	\$0.10
9013. Milk Board (Milk Vendors)	\$0.20
9014. Dandenong Valley Authority (Cardinia Creek)	\$0.20
9015. Motor Car (Amendment)	\$0.50
9016. State Library and National Museum Buildings Committee	\$0.20
9017. Superannuation Benefits	\$0.20
9018. Social Welfare (Administration)	\$0.20
9019. Statute Law Revision	\$0.70
9020. Emerald Tourist Railway	\$0.50
9021. The Uniting Church in Australia	\$0.60
9022. Local Government (Amendment)	\$0.60
9023. Health Commission	\$1.10
9024. Geelong Regional Commission	\$0.60
9025. Equal Opportunity	\$0.60

ACTS REPRINTED IN ACCORDANCE WITH THE AMENDMENTS INCORPORATION ACT 1958 (No. 6422), AND FOR SALE AT THE SALE OF PUBLICATIONS BRANCH OF THE GOVERNMENT PRINTING OFFICE, 7A PARLIAMENT PLACE, MELBOURNE, 3002

Postage costs must be added to your remittance when ordering by mail as follows:—

Act Price	Postage Cost
10c-40c	20c
45c-70c	30c
75c-\$1.70	40c
\$1.75-\$4.00	60c
Above \$4.00	86c

ACTS REPRINTED IN ACCORDANCE WITH THE AMENDMENTS INCORPORATION ACT 1958 (No. 6422)—continued

No.	Price
6194. Agricultural Colleges (First Reprint—Incorporating amendments up to No. 7302)	\$0.15
6198. Anzac Day (First Reprint—Incorporating amendments up to No. 8344)	\$0.15
7117. Appeal Costs Fund Act 1964 (Second Reprint—Incorporating amendments up to No. 7488)	\$0.35
6201. Architects (First Reprint—Incorporating amendments up to No. 8077)	\$0.30
6202. Auction Sales (First Reprint—Incorporating amendments up to No. 8490)	\$0.35
6203. Audit (First Reprint—Incorporating amendments up to No. 7377)	\$0.35
6206. Barley Marketing (First Reprint—Incorporating amendments up to No. 9005)	\$0.30
6208. Benefit Associations (First Reprint—Incorporating amendments up to No. 6961)	\$0.65
8004. Boiler and Pressure Vessels Act 1970 (First Reprint—Incorporating amendments up to No. 8389)	\$0.45
6529. Bread Industry Act 1959 (First Reprint—Incorporating amendments up to No. 7728)	\$0.30
6973. Building Contracts (Deposits) Act 1962 (First Reprint—Incorporating amendments from No. 7315)	\$0.10
6210. Building Societies (Third Reprint—Incorporating amendments up to No. 8405)	\$0.65
6213. Cancer (First Reprint—Incorporating amendments up to No. 7455)	\$0.35
6214. Carriers and Innkeepers (Second Reprint—Incorporating amendments up to No. 8534)	\$0.20
6215. Cattle Breeding (First Reprint—Incorporating amendments up to No. 6886)	\$0.10
6217. Cemeteries (First Reprint—Incorporating amendments up to No. 7672)	\$0.30
8477. Children's Court Act 1973 (First Reprint—Incorporating amendments up to No. 8731)	\$0.95
6220. Clean Air (Third Reprint—Incorporating amendments up to No. 8324)	\$0.15
6221. Coal Mines (First Reprint—Incorporating amendments up to No. 7628)	\$1.05
6222. Commercial Goods Vehicles (Third Reprint—Incorporating amendments up to No. 8525)	\$0.55
6223. Commonwealth Arrangements (First Reprint—Incorporating amendments from No. 7809)	\$0.10
6839. Companies (Sixth Reprint—Incorporating amendments up to No. 8788)	\$7.90
8276. Consumer Affairs Act 1972 (Third Reprint—Incorporating amendments up to No. 8824)	\$1.15
8750. Constitution Act 1975, The (First Reprint—Incorporating amendments up to No. 8951)	\$0.85
6224. Constitution Act Amendment, The (First Reprint—Incorporating amendments up to No. 8086)	\$3.05
6225. Co-operation Act (Third Reprint—Incorporating amendments up to No. 8339)	\$0.85
6226. Co-operative Housing Societies (Second Reprint—Incorporating amendments up to No. 7575)	\$0.53
6227. Coroners (Second Reprint—Incorporating amendments up to No. 8184)	\$0.35
6228. Country Fire Authority (Third Reprint—Incorporating amendments up to No. 8813)	\$1.25
6229. Country Roads (Fourth Reprint—Incorporating amendments up to No. 8573)	\$1.05
6230. County Court (Third Reprint—Incorporating amendments up to No. 8625)	\$0.65
6231. Crimes (Fifth Reprint—Incorporating amendments up to No. 8679)	\$2.35
6232. Crown Proceedings (Second Reprint—Incorporating amendments up to No. 8731)	\$0.40
6233. Dairy Products (First Reprint—Incorporating amendments up to No. 7945)	\$0.30
7060. Dandenong Valley Authority Act 1963 (First Reprint—Incorporating amendments up to No. 7523)	\$0.35
6235. Dietitians Registration (First Reprint—Incorporating amendments up to No. 6886)	\$0.20
4989. Discharged Servicemen's Preference Act 1943 (Second Reprint—Incorporating amendments up to No. 7991)	\$0.20
6815. Disposal of Uncollected Goods Act 1961 (Second Reprint—Incorporating amendments up to No. 8246)	\$0.30
8079. Dog Act 1970 (First Reprint—Incorporating amendments up to No. 8664)	\$0.30
6237. Drainage Areas (First Reprint—Incorporating amendments up to No. 7276)	\$0.35

No.	Price
6189. Acts Interpretation (Fourth Reprint—Incorporating amendments up to No. 8305)	\$0.35
6191. Administration and Probate (Fourth Reprint—Incorporating amendments up to No. 7874)	\$0.75
7147. Adoption of Children (First Reprint—Incorporating amendments up to Act No. 8602)	\$0.75

ACTS REPRINTED IN ACCORDANCE WITH THE AMENDMENTS
INCORPORATION ACT 1958 (No. 6422)—*continued*

No.	Price
6239. Dried Fruits Act 1968 (<i>First Reprint</i> —Incorporating amendments up to No. 7337)	\$0.25
6240. Education Act (<i>Second Reprint</i> —Incorporating amendments up to No. 8659)	\$0.95
6241. Electric Light and Power (<i>First Reprint</i> —Incorporating amendments up to No. 7315)	\$0.30
8056. Environment Protection Act 1970 (<i>Second Reprint</i> —Incorporating amendments up to No. 8560)	\$0.55
6244. Essential Services (<i>First Reprint</i> —Incorporating amendments up to No. 8353)	\$0.20
6245. Estate Agents—(<i>Fifth Reprint</i> —Incorporating amendments up to No. 8490)	\$0.85
6246. Evidence (<i>Fourth Reprint</i> —Incorporating amendments up to No. 8228)	\$1.05
7499. Extractive Industries Act 1966 (<i>Third Reprint</i> —Incorporating amendments up to No. 8647)	\$0.45
7733. Fences (<i>First Reprint</i> —Incorporating amendments from No. 7876)	\$0.55
6468. Filled Milk (<i>First Reprint</i> —Incorporating amendments up to No. 6886)	\$0.15
6251. Firearms (<i>Fifth Reprint</i> —Incorporating amendments up to No. 8427)	\$1.05
7780. Fisheries Act 1968 (<i>First Reprint</i> —Incorporating amendments up to No. 8694)	\$1.05
6916. Foreign Judgments Act 1962 (<i>First Reprint</i> including amendments made by No. 7332)	\$0.15
6585. Forests (Pulpwood Agreement). (Incorporating amendments up to No. 6886)	\$0.15
6254. Forests (<i>Second Reprint</i> —Incorporating amendments up to No. 8702)	\$1.35
6255. Friendly Societies (<i>First Reprint</i> —Incorporating amendments up to No. 7554)	\$0.60
6256. Fruit and Vegetables (<i>First Reprint</i> —Incorporating amendments up to No. 6944)	\$0.30
6260. Gas and Fuel Corporation (<i>First Reprint</i> —Incorporating amendments up to No. 7422)	\$0.70
6262. Geelong Harbor Trust (<i>First Reprint</i> —Incorporating amendments up to No. 7547)	\$0.45
6263. Geelong Waterworks and Sewerage (<i>First Reprint</i> —Incorporating amendments up to No. 7547)	\$0.75
8176. Gift Duty Act 1971 (<i>First Reprint</i> —Incorporating amendments from No. 8202)	\$0.55
6265. Goods (<i>Sixth Reprint</i> —Incorporating amendments up to No. 8425)	\$0.45
6266. Grain Elevators (<i>First Reprint</i> —Incorporating amendments up to No. 7486)	\$0.35
7849. Groundwater (<i>First Reprint</i> —Incorporating amendments up to No. 8153)	\$0.45
6267. Hairdressers Registration (<i>First Reprint</i> —Incorporating amendments up to No. 7659)	\$0.30
6269. Hawkers and Pedlars (<i>Second Reprint</i> —Incorporating amendments up to No. 8247)	\$0.40
6270. Health (<i>Third Reprint</i> —Incorporating amendments up to No. 8506)	\$3.25
6531. Hire Purchase Act 1959 (<i>Second Reprint</i> —Incorporating amendments from No. 8232)	\$0.55
6933. Home Finance Act 1962 (<i>First Reprint</i> —Incorporating amendments up to No. 7363)	\$0.25
6274. Hospitals and Charities (<i>Second Reprint</i> —Incorporating amendments up to No. 7455)	\$0.50
6275. Housing (<i>Third Reprint</i> —Incorporating amendments up to No. 8713)	\$2.40
6276. Imprisonment of Fraudulent Debtors (<i>First Reprint</i> —Incorporating amendments up to No. 7876)	\$0.35
6277. Industrial and Provident Societies (<i>First Reprint</i> —Incorporating amendments up to No. 7547)	\$0.35
6279. Instruments (<i>Fifth Reprint</i> —Incorporating amendments up to No. 8565)	\$0.75
6280. Judicial Proceedings Reports (<i>First Reprint</i> —Incorporating amendments up to No. 7596)	\$0.15
7651. Juries (<i>First Reprint</i> —Incorporating amendments up to No. 8170)	\$0.55
6283. Labour and Industry (<i>Sixth Reprint</i> —Incorporating amendments up to No. 8642)	\$1.50
6284. Land (<i>Third Reprint</i> —Incorporating amendments up to No. 8702)	\$3.25
6534. Land Settlement Act 1959 (<i>First Reprint</i> —Incorporating amendments up to No. 7328)	\$0.30
6288. Land Surveyors (<i>First Reprint</i> —Incorporating amendments up to No. 7065)	\$0.30
6289. Land Tax (<i>Second Reprint</i> —Incorporating amendments up to No. 7466)	\$0.40

ACTS REPRINTED IN ACCORDANCE WITH THE AMENDMENTS
INCORPORATION ACT 1958 (No. 6422)—*continued*

No.	Price
6285. Landlord and Tenant (<i>Fourth Reprint</i> —Incorporating amendments up to No. 8208)	\$1.15
6286. Lands Compensation Act (<i>Third Reprint</i> —Incorporating amendments up to No. 8899)	\$0.45
6290. Latrobe Valley (<i>First Reprint</i> —Incorporating amendments up to No. 7332)	\$0.35
7919. Legal Aid—(<i>First Reprint</i> —Incorporating amendments up to No. 8427)	\$0.30
6291. Legal Profession Practice Act (<i>Fourth Reprint</i> —Incorporating amendments up to No. 8778)	\$1.45
6292. Libraries (<i>First Reprint</i> —Incorporating amendments up to No. 7364)	\$0.15
7629. Lifts and Cranes Act 1967 (<i>First Reprint</i> —Incorporating amendments up to No. 8320)	\$0.30
6295. Limitation of Actions (<i>Third Reprint</i> —Incorporating amendments up to No. 8300)	\$0.35
7695. Liquor Control Act 1958 (<i>Third Reprint</i> —Incorporating amendments up to No. 8598)	\$1.35
7145. Litter Act 1964 (<i>Second Reprint</i> —Incorporating amendments up to No. 8702)	\$0.20
6298. Local Authorities Superannuation (<i>Second Reprint</i> —Incorporating amendments up to No. 7161)	\$0.40
6299. Local Government (<i>Third Reprint</i> —Incorporating amendments up to No. 8781)	\$10.90
7429. Lotteries Gaming and Betting—(<i>First Reprint</i> —Incorporating amendments up to No. 8581)	\$0.75
8184. Magistrates' Courts (<i>First Reprint</i> —Incorporating amendments up to No. 8718)	\$0.75
7289. Maintenance (<i>First Reprint</i> —Incorporating amendments up to No. 8036)	\$1.05
6302. Marine (Incorporating amendments up to No. 7350)	\$0.72
6303. Marine Stores and Old Metals (<i>First Reprint</i> —Incorporating amendments up to No. 7876)	\$0.35
6304. Marketing of Primary Products (<i>First Reprint</i> —Incorporating amendments up to No. 7491)	\$0.45
6305. Markets Act (<i>Second Reprint</i> —Incorporating amendments up to No. 8247)	\$0.30
6306. Marriage (<i>Second Reprint</i> —Incorporating amendments up to No. 8602)	\$0.45
6307. Masseurs (<i>First Reprint</i> —Incorporating amendments up to No. 7566)	\$0.20
6309. Medical Act 1958 (<i>Third Reprint</i> —Incorporating amendments up to No. 8593)	\$0.45
8061. Medical Practitioners (<i>First Reprint</i> —Incorporating amendments up to No. 8754)	\$0.75
6310. Melbourne and Metropolitan Board of Works (<i>Fourth Reprint</i> —Incorporating amendments up to No. 8650)	\$1.95
6311. Melbourne and Metropolitan Tramways (<i>First Reprint</i> —Incorporating amendments up to No. 7622)	\$0.70
6312. Melbourne Harbor Trust (<i>Second Reprint</i> —Incorporating amendments up to No. 8796)	\$1.35
6405. Melbourne University (<i>First Reprint</i> —Incorporating amendments up to No. 7871)	\$0.40
6605. Mental Health (<i>Second Reprint</i> —Incorporating amendments up to No. 8679)	\$0.75
6315. Metropolitan Fire Brigades (<i>Second Reprint</i> —Incorporating amendments up to No. 8165)	\$0.65
6316. Mildura Irrigation and Water Trusts (<i>First Reprint</i> —Incorporating amendments up to No. 7448)	\$0.75
6317. Milk and Dairy Supervision (<i>Second Reprint</i> —Incorporating amendments up to No. 8655)	\$0.85
6318. Milk Board (Incorporating amendments up to No. 7093)	\$0.22
6319. Milk Pasteurization (<i>First Reprint</i> —Incorporating amendments up to No. 7480)	\$0.18
6320. Mines (<i>Second Reprint</i> —Incorporating amendments up to No. 7876)	\$1.25
6184. Monash University (<i>First Reprint</i> —Incorporating amendments up to No. 7533)	\$0.30
6324. Money Lenders (<i>Fourth Reprint</i> —Incorporating amendments up to No. 8490)	\$0.55
6832. Motor Boating Act 1961 (<i>Third Reprint</i> —Incorporating amendment up to No. 8662)	\$0.55
6325. Motor Car Act 1958 (<i>Fifth Reprint</i> —Incorporating amendments up to No. 8657)	\$2.25
6713. National Fitness Council of Victoria Act 1960 (<i>First Reprint</i> —Incorporating amendments up to No. 8344)	\$0.20

ACTS REPRINTED IN ACCORDANCE WITH THE AMENDMENTS
INCORPORATION ACT 1958 (No. 6422)—*continued*

No.	Price
6705 Navigable Waters (Oil Pollution) Act 1960. (First Reprint—Incorporating amendments up to No. 7890) ..	\$0.30
6328. Nurses Act (Third Reprint—Incorporating amendments up to No. 8743) ..	\$0.65
8414. Ombudsman Act 1973 (First Reprint—Incorporating amendments up to No. 8884) ..	\$0.45
6329. Optometrists Registration (First Reprint—Incorporating amendments up to No. 7409) ..	\$0.30
7723. Parliamentary Salaries and Superannuation (First Reprint—Incorporating amendments up to No. 8687) ..	\$0.35
6330. Partnership (Second Reprint—Incorporating amendments up to No. 7315) ..	\$0.35
6331. Patriotic Funds (First Reprint—Incorporating amendments up to No. 7338) ..	\$0.25
6332. Pawnbrokers Act 1958 (Second Reprint—Incorporating amendments up to No. 8181) ..	\$0.35
7417. Pensions Supplementation (First Reprint—Incorporating amendments up to No. 8475) ..	\$0.20
6257. Pesticides Act 1958 (Second Reprint—Incorporating amendments up to No. 8589) ..	\$0.35
6335. Petrol Pumps (Second Reprint—Incorporating amendments up to No. 7315) ..	\$0.15
6334. Petroleum (First Reprint—Incorporating amendments up to No. 7876) ..	\$0.65
6889. Poisons Act 1962 (Fourth Reprint—Incorporating amendments up to No. 8456) ..	\$0.95
6337. Police Offences Act 1958 (Third Reprint—Incorporating amendments up to No. 8433) ..	\$0.45
6388. Police Regulation (Third Reprint—Incorporating amendments up to No. 8722) ..	\$0.95
6340. Portland Harbor Trust (First Reprint—Incorporating amendments up to No. 7475) ..	\$0.35
7498. Port Phillip Authority Act 1966 (Second Reprint—Incorporating amendments from No. 8081) ..	\$0.15
6341. Pounds (First Reprint—Incorporating amendments up to No. 7315) ..	\$0.25
6342. Printers and Newspapers (First Reprint—Incorporating amendments up to No. 7876) ..	\$0.15
7494. Private Agents Act 1966 (Second Reprint—Incorporating amendments up to No. 8427) ..	\$0.45
6344. Property Law (Third Reprint—Incorporating amendments up to No. 8181) ..	\$1.95
6345. Public Account (First Reprint—Incorporating amendments up to No. 8012) ..	\$0.20
6346. Public Authorities Marks (First Reprint—Incorporating amendments from No. 7315) ..	\$0.10
8656. Public Service (First Reprint—Incorporating amendments up to No. 8806) ..	\$0.95
6350. Public Trustee Act 1958 (Second Reprint—Incorporating amendments up to No. 8125) ..	\$1.05
6353. Racing (Fourth Reprint—Incorporating amendments up to No. 8690) ..	\$1.55
6355. Railways (First Reprint—Incorporating amendments up to No. 7475) ..	\$0.75
6564. Registration of Births Deaths and Marriages Act 1959 (First Reprint—Incorporating amendments up to No. 7332) ..	\$0.25
6358. River Improvements Act (Second Reprint—Incorporating amendments up to No. 8967) ..	\$0.85
2596. River Murray Waters Act 1915 (First Reprint—Incorporating amendments up to No. 7061) ..	\$0.35
6359. Road Traffic (Fourth Reprint—Incorporating amendments up to No. 8353) ..	\$0.35
6360. Rural Finance (First Reprint—Incorporating amendments up to No. 7328) ..	\$0.15
6846. Rural Finance and Settlement Commission Act 1961 (First Reprint—Incorporating amendments up to No. 7332) ..	\$0.30
6917. Sale of Human Blood Act 1962 (First Reprint—Incorporating amendments from No. 7332) ..	\$0.10
6975. Sale of Land Act 1962 (Second Reprint—Incorporating amendments up to No. 7898) ..	\$0.35
8146. Scaffolding Act 1971 (Second Reprint—Incorporating amendments up to No. 8666) ..	\$0.35
6363. Second-hand Dealers (First Reprint—Incorporating amendments up to No. 7529) ..	\$0.25
6367. Settled Land (Second Reprint—Incorporating amendments up to No. 7065) ..	\$0.85
6368. Sewerage Districts (Second Reprint—Incorporating amendments up to No. 7547) ..	\$0.75

ACTS REPRINTED IN ACCORDANCE WITH THE AMENDMENTS
INCORPORATION ACT 1958 (No. 6422)—*continued*

No.	Price
6369. Shearers Accommodation (First Reprint—Incorporating amendments up to No. 7876) ..	\$0.35
6809. Sheep Owners Protection Act 1961 (Third Reprint—Incorporating amendments up to No. 8247) ..	\$0.20
8089. Social Welfare Act 1970 (First Reprint—Incorporating amendments up to No. 8821) ..	\$1.90
6372. Soil Conservation and Land Utilization Act (Third Reprint—Incorporating amendments up to No. 8432) ..	\$0.45
6373. Soldier Settlement (First Reprint—Incorporating amendments up to No. 7328) ..	\$0.42
6375. Stamps Act 1958 (Sixth Reprint—Incorporating amendments up to No. 8624) ..	\$2.15
6377. State Electricity Commission (Second Reprint—Incorporating amendments up to No. 7421) ..	\$0.65
6378. State Relief Committee (First Reprint—Incorporating amendments from No. 6886) ..	\$0.10
6379. State Savings Bank Act 1958 (Third Reprint—Incorporating amendments up to No. 8519) ..	\$0.95
6380. Statistics (First Reprint—Incorporating amendments up to No. 6961) ..	\$0.15
6877. Stock (Artificial Breeding) Act 1962 (First Reprint—Incorporating amendments up to No. 8709) ..	\$0.30
6383. Stock Foods (First Reprint—Incorporating amendments up to No. 7607) ..	\$0.28
6384. Stock Medicines (First Reprint—Incorporating amendments up to No. 7726) ..	\$0.20
7551. Strata Titles Act 1967 (Third Reprint—Incorporating amendments up to No. 8661) ..	\$0.65
6886. Subordinate Legislation Act 1962 (Second Reprint—Incorporating amendments up to No. 8127) ..	\$0.15
7405. Summary Offences Act 1966 (Second Reprint—Incorporating amendments up to No. 8276) ..	\$0.55
7634. Sunday Entertainment (First Reprint—Incorporating amendments up to No. 8173) ..	\$0.15
6386. Superannuation (Third Reprint—Incorporating amendments up to No. 8717) ..	\$1.35
6387. Supreme Court (First Reprint—Incorporating amendments up to No. 7522) ..	\$0.75
6388. Survey Co-ordination (First Reprint—Incorporating amendments up to No. 8107) ..	\$0.35
6390. Tattersall Consultations (First Reprint—Incorporating amendments up to No. 8289) ..	\$0.15
6390. Tattersall Consultations (Second Reprint—Incorporating amendments up to No. 8982) ..	\$0.30
6391. Teaching Service (Second Reprint—Incorporating amendments up to No. 8691) ..	\$0.55
6393. Theatres (First Reprint—Incorporating amendments up to No. 8161) ..	\$0.15
6849. Town and Country Planning Act 1961 (Fifth Reprint—Incorporating amendments up to No. 8716) ..	\$1.25
6397. Trade Unions (Second Reprint—Incorporating amendments up to No. 8181) ..	\$0.20
6399. Transfer of Land (Fifth Reprint—Incorporating amendments up to No. 8531) ..	\$1.15
6400. Transport Regulation Act (Second Reprint—Incorporating amendments up to No. 8549) ..	\$0.45
6401. Trustee (Third Reprint—Incorporating amendments up to No. 7833) ..	\$0.85
6402. Trustee Companies (First Reprint—Incorporating amendments up to No. 7858) ..	\$0.35
6879. Unclaimed Moneys Act 1962 (Second Reprint—Incorporating amendments up to No. 8448) ..	\$0.20
7095. Underseas Mineral Resources Act 1963 (First Reprint—Incorporating amendments from No. 7591) ..	\$0.10
6653. Valuation of Land Act 1960 (Fourth Reprint—Incorporating amendments up to No. 8817) ..	\$0.85
6407. Vegetation and Vine Diseases (First Reprint—Incorporating amendments up to No. 7423) ..	\$0.30
6408. Venereal Diseases (First Reprint—Incorporating amendments made by Act No. 6886) ..	\$0.55
6409. Vermin & Noxious Weeds (First Reprint—Incorporating amendments up to No. 7463) ..	\$0.35
6410. Veterinary Surgeons (First Reprint—Incorporating amendments up to No. 7343) ..	\$0.15

ACTS REPRINTED IN ACCORDANCE WITH THE AMENDMENTS INCORPORATION ACT 1958 (No. 6422)—*continued*

No.	Price
7291. Victoria Institute of Colleges Act 1965 (Second Reprint—Incorporating amendments up to No. 8710)	\$0.65
6412. Warehousemen's Liens (First Reprint—Incorporating amendments up to No. 7876)	\$0.15
6413. Water (Third Reprint—Incorporating amendments up to No. 8729)	\$3.45
6414. Weights and Measures (Third Reprint—Incorporating amendments up to No. 8068)	\$1.05
6415. Wild Flowers and Native Plants Protection (First Reprint—Incorporating amendments up to No. 6976)	\$0.15
6416. Wills (Second Reprint—Incorporating amendments up to No. 7238)	\$0.25
6417. Wire Netting (First Reprint—Incorporating amendments up to No. 7876)	\$0.65
6419. Workers Compensation Act (Seventh Reprint—Incorporating amendments up to No. 8804)	\$1.45
6420. Wrongs Act (Second Reprint—Incorporating amendments up to No. 8915)	\$0.45
8344. Youth, Sport and Recreation Act 1972 (First Reprint—Incorporating amendments up to No. 8550)	\$0.35

F. D. ATKINSON,
Government Printer

KYNETON GUARDIAN PTY. LTD., P.O. Box 18, Kyneton, Victoria 3444.

LOVELL'S SHEPPARTON NEWSAGENCY, 246 Wyndham Street, Shepparton, Victoria 3630.

THE MERCANTILE EXCHANGE, 34 Queen Street, Melbourne, Victoria 3000.

MCGILL'S AUTHORIZED NEWSAGENCY, 183-5 Elizabeth Street, Melbourne, Victoria 3000.

MCNAUGHTON, P. R. & L. A., 112-114 Gray Street, Hamilton, Victoria 3300.

POWNEY'S AUTHORIZED NEWSAGENCY, 293 Hargreaves Street, Bendigo, Victoria 3550.

PURDIE, J., & CO., 138 Moorabool Street, Geelong, Victoria 3220.

SALE AUTHORIZED NEWSAGENCY, 142 Raymond Street, Sale, Victoria 3850.

SKINNER'S AUTHORIZED NEWSAGENCY, 49-51 Franklin Street, Traralgon, Victoria 3844.

VANCE'S AUTHORIZED NEWSAGENCY, 83 Murray Street, Wangaratta 3677.

VERNONS OF RICHMOND, 162 Bridge Road, Richmond, Victoria 3121.

VIEW POINT AUTHORIZED NEWSAGENCY, 4 View-Point, Bendigo, Victoria 3550.

A copy of the Gazette is filed at each place for public reference.

AGENTS FOR THE "VICTORIA GOVERNMENT GAZETTE"

The following have been appointed agents to receive Advertisements and Subscriptions for the Victoria Government Gazette:—

ARMSTRONG'S AGENCY, 217 Queen Street, Melbourne, Victoria 3000.
ARNALL & JACKSON, 390 Barkly Street, Brunswick, Victoria 3056
BAIRNSDALE AUTHORIZED NEWSAGENCY, 132 Main Street, Bairnsdale, Victoria 3875.
BENALLA AUTHORIZED NEWSAGENCY, 45 Bridge Street, Benalla, Victoria 3672.
BLANE'S AUTHORIZED NEWSAGENTS, 162 Murray Street, Colac, Victoria 3250.
CARTER, R. G., ADVERTISING SERVICE PTY. LTD., Suite 11, 285 Carlisle Street, Balaclava, Victoria 3183.
DAVIS, WM. (MILDURA) PTY. LTD., 126 Eighth Street, Mildura, Victoria 3500.
DIXON'S NEWSAGENCY, 89 Firebrace Street, Horsham, Victoria 3400.
FAROE, S. W. & E. P., 79 Henty Street, Casterton, Victoria 3311.
FRANKS, H., & CO., 184 Ryrie Street, Geelong, Victoria 3220.
GATLEY, A. & J., 250 Lonsdale Street, Dandenong, Victoria 3175.
GORDON & GOTCH AUSTRALASIA LTD., 25-37 Huntingdale Road, Burwood, Victoria 3125.
GULLAN'S NEWSAGENCY, 88 Bridge Street, Ballarat, Victoria 3350.
HAMPTON, A. C., 243 Mitchell Street, Bendigo, Victoria, 3550.
HARSTON, PARTRIDGE & CO. PTY. LTD., 455 Little Collins Street, Melbourne, Victoria 3000.

CONTENTS

PAGE

Acts of Parliament on Sale at the Government Printing Office	2976
Appointments	2944
Bank Holidays	2928
Contracts	2938
Estates of Deceased Persons	2943
Government Notices	2928
Impounding	2975
Lands	2955
Melbourne and Metropolitan Board of Works—Notice	2940
Minerals and Energy	2933
Notice of Making of Statutory Rules	2975
Orders in Council—	
Acts—Local Government; Land; Housing; Soil Conservation and Land Utilization; Forests; Hospitals and Charities; Superannuation; Historic Buildings; Water; Latrobe Valley; Sewerage Districts.	2946 et seq
Police Sale	2936
Private Advertisements	2959
Proclamations	2927
Public Holiday—Royal Agricultural Show	2928
Public Holidays	2928
Regulations—	
Act—Teaching Service	2958
Resignations	2946
Tenders	2959
Transport Regulation Board—Public Hearings	2930
Waterworks Trust	2935