



Victoria Government Gazette

No. 34—Wednesday, 14 May 1980

PROCLAMATIONS

ACTS OF PARLIAMENT

PROCLAMATION

By His Excellency the Governor of the State of Victoria and its Dependencies in the Commonwealth of Australia, &c., &c., &c.

I, the Governor of the State of Victoria, in the Commonwealth of Australia, do hereby declare that I have this day assented, in Her Majesty's name, to the Bills passed by the Parliament of the said State, the titles whereof are hereunder set forth, together with the short titles, that is to say:—

- No. 9385. "An Act to make further provision with respect to the Payment of certain Rates and Charges." (*Pensioners' Rates Remission Act 1980.*)
- No. 9386. "An Act to amend the *Motor Car Traders Act 1973* and for other purposes." (*Motor Car Traders (Amendment) Act 1980.*)
- No. 9387. "An Act to establish a Victorian Solar Energy Council to encourage, promote and review Research into and the Development of the Uses and potential uses of Solar Energy and for other purposes." (*Victorian Solar Energy Council Act 1980.*)
- No. 9388. "An Act to amend the *Racing Act 1958*, and the *Lotteries Gaming and Betting Act 1966* and for other purposes." (*Racing (Amendment) Act 1980.*)
- No. 9389. "An Act to amend the *Country Fire Authority Act 1958.*" (*Country Fire Authority (Amendment) Act 1980.*)
- No. 9390. "An Act to validate Instruments executed by the Minister for Local Government in exercise of the power conferred by section 181 of the *Local Government Act 1958* to remove certain disabilities from certain Councillors of certain Municipalities, to amend section 181 of the *Local Government Act 1958* and for other purposes." (*Local Government (Validation) Act 1980.*)
- No. 9391. "An Act to amend the *Professional Boxing Control Act 1975.*" (*Professional Boxing Control (Amendment) Act 1980.*)

Given under my Hand and the Seal of the State of Victoria aforesaid, at Melbourne, this thirteenth day of May, in the year of our Lord One thousand nine hundred and eighty and in the twenty-ninth year of the reign of Her Majesty Queen Elizabeth II.

(L.S.)

HENRY WINNEKE

By His Excellency's Command

R. J. HAMER
Premier

GOD SAVE THE QUEEN!

No. 9385. Shall in relation to any rate or charge which commences or is deemed to commence on or after 1 July 1980—apply as amended by this Act; and shall not apply in relation to any rate or charge which commences or is deemed to commence before 1 July 1980.

No. 9386. Shall come into operation on the day on which it receives the Royal Assent.

No. 9387. Shall come into operation on a day to be fixed by proclamation.

No. 9388. Several provisions of this Act shall come into operation on a day or the respective days to be fixed by proclamation.

No. 9389. Several provisions of this Act shall come into operation on the day or the respective days to be fixed by proclamation.

No. 9390. Shall come into operation on the day upon which it receives the Royal Assent.

No. 9391. Several provisions of this Act shall come into operation on the day or the respective days to be fixed by proclamation.

ACTS OF PARLIAMENT

PROCLAMATION

By His Excellency the Governor of the State of Victoria and its Dependencies in the Commonwealth of Australia, &c., &c., &c.

I, the Governor of the State of Victoria, in the Commonwealth of Australia, do hereby declare that I have this day assented, in Her Majesty's name, to the Bills passed by the Parliament of the said State, the titles whereof are hereunder set forth, together with the short titles, that is to say:—

- No. 9392. "An Act to amend the *Police Regulation Act 1958* with respect to the Entitlement of Police Reservists to Long Service Leave and Recreation Leave Allowances, and for other purposes." (*Police Regulation (Retired Police Reserve) Act 1980.*)
- No. 9393. "An Act to amend the *Local Authorities Superannuation Act 1958* and for other purposes." (*Local Authorities Superannuation (Amendment) Act 1980.*)

Given under my Hand and the Seal of the State of Victoria aforesaid, at Melbourne, this thirteenth day of May, in the year of our Lord One thousand nine hundred and eighty and in the twenty-ninth year of the reign of Her Majesty Queen Elizabeth II.

(L.S.)

HENRY WINNEKE

By His Excellency's Command

R. J. HAMER
Premier

GOD SAVE THE QUEEN!

No. 9392. Several provisions of this Act shall come into operation on a day or on the respective days to be fixed by proclamation.

No. 9393. Provisions of this Act shall be deemed to have come into operation on 1 March 1980.

Marketing of Primary Products Act 1958

DECLARING THAT ORANGES, MANDARINS AND GRAPEFRUIT SHALL BECOME THE PROPERTY OF THE CITRUS FRUIT MARKETING BOARD FOR A FURTHER PERIOD OF TWO (2) YEARS

PROCLAMATION

By His Excellency the Governor of the State of Victoria and its Dependencies in the Commonwealth of Australia, &c., &c., &c.

Whereas by sub-section (1) of Section 17 of the *Marketing of Primary Products Act 1958*, it is enacted that where a product has been declared a commodity and a board has been appointed in relation thereto, the Governor in Council may by proclamation—

- (a) provide and declare that the commodity shall forthwith upon the date of publication of the proclamation or on, from and after a later date specified in the proclamation, be divested from the producers of the commodity and become vested in and be the absolute property of the board as the owner thereof, and that upon any of the commodity coming into existence within a time specified in the same or a subsequent proclamation it shall by virtue of that Act become vested in and be the absolute property of the board as the owner thereof; and
- (b) make such further provision as will enable the board effectively to obtain possession of the commodity as such owner and to deal with the same;

And whereas by a proclamation made on the sixth day of February, 1973, under the provisions of Section 7 of the said Act the Governor in Council declared oranges, mandarins and grapefruit to be a commodity under and for the purposes of the said Act: And whereas by an Order made on the fourth day of December, 1973, the Governor in Council appointed a marketing board in relation to oranges, mandarins and grapefruit and assigned to such board the name of "The Citrus Fruit Marketing Board": Now therefore, I, the Governor of the State of Victoria in the Commonwealth of Australia, by and with the advice of the Executive Council of the said State, do by this my proclamation hereby provide and declare that on, from and after the fifteenth day of May, 1980, all oranges, mandarins and grapefruit shall subject to and in accordance with the *Marketing of Primary Products Act 1958* be divested from the producers thereof, and become vested in and be the absolute property of The Citrus Fruit Marketing Board as the owner thereof and that upon any oranges, mandarins or grapefruit coming into existence within two (2) years from the fifteenth day of May, 1980, they shall by virtue of and subject to and in accordance with the said Act become vested in and be the absolute property of The Citrus Fruit Marketing Board as the owner of the abovementioned commodity effectively to obtain possession thereof and to deal with the same I do further provide that all such oranges, mandarins and grapefruit shall subject to and in accordance with the provisions of the said Act be delivered by the producers thereof to The Citrus Fruit Marketing Board or its authorized agent within such times at such places and in such manner as The Citrus Fruit Marketing Board by public notice, or in a particular case in writing, directs or as are prescribed by Regulations made under the said Act.

Given under my Hand and the Seal of the State of Victoria aforesaid, at Melbourne this thirteenth day of May, in the year of Our Lord One thousand nine hundred and eighty, and in the twenty-ninth year of the reign of Her Majesty Elizabeth the Second, Queen of Australia.

(L.S.) HENRY WINNEKE

By His Excellency's Command

I. W. SMITH,
Minister of Agriculture

GOD SAVE THE QUEEN!

Marketing of Primary Products Act 1958

DECLARING THAT TOBACCO LEAF SHALL BECOME THE PROPERTY OF THE TOBACCO LEAF MARKETING BOARD FOR A FURTHER PERIOD OF TWO (2) YEARS

PROCLAMATION

By His Excellency the Governor of the State of Victoria and its Dependencies in the Commonwealth of Australia, &c., &c., &c.

Whereas by sub-section (1) of Section 17 of the *Marketing of Primary Products Act 1958*, it is enacted that where a product has been declared a commodity and a board has been appointed in relation thereto, the Governor in Council may by proclamation—

- (a) provide and declare that the commodity shall forthwith upon the date of publication of the proclamation or on, from and after a later date specified in the proclamation, be divested from the producers of the commodity and become vested in and be the absolute property of the board as the owner thereof, and that upon any of the commodity coming into existence within a time specified in the same or a subsequent proclamation it shall by virtue of that Act become vested in and be the absolute property of the board as the owner thereof; and
- (b) make such further provision as will enable the board effectively to obtain possession of the commodity as such owner and to deal with the same;

And whereas by a proclamation made on the twentieth day of December, 1963, under the provisions of Section 7 of the said Act the Governor in Council declared tobacco leaf to be a commodity under and for the purposes of the said Act:

And whereas by an Order made on the twenty-second day of April, 1964, the Governor in Council appointed a marketing board in relation to tobacco leaf and assigned to such board the name of "The Tobacco Leaf Marketing Board":

Now therefore, I, the Governor of the State of Victoria in the Commonwealth of Australia, by and with the advice of the Executive Council of the said State, do by this my proclamation hereby provide and declare that on, from and after the thirteenth day of May, 1980, all tobacco leaf shall subject to and in accordance with the *Marketing of Primary Products Act 1958* be divested from the producers of tobacco leaf and become vested in and be the absolute property of The Tobacco Leaf Marketing Board as the owner thereof and that upon any tobacco leaf coming into existence within two (2) years from the thirteenth day of May, 1980, it shall by virtue of and subject to and in accordance with the said Act become vested in and be the absolute property of The Tobacco Leaf Marketing Board as the owner thereof: And to enable The Tobacco Leaf Marketing Board as the owner of the above-mentioned commodity effectively to obtain possession thereof and to deal with the same I do further provide that all such tobacco leaf shall subject to and in accordance with the provisions of the said Act be delivered by the producers thereof to The Tobacco Leaf Marketing Board or its authorized agent within such times at such places and in such manner as The Tobacco Leaf Marketing Board by public notice, or in a particular case in writing, directs or as are prescribed by Regulations made under the said Act.

Given under my Hand and the Seal of the State of Victoria aforesaid, at Melbourne, this thirteenth day of May, in the year of Our Lord One thousand nine hundred and eighty, and in the twenty-ninth year of the reign of Her Majesty Elizabeth the Second, Queen of Australia.

(L.S.) HENRY WINNEKE

By His Excellency's Command

I. W. SMITH,
Minister of Agriculture

GOD SAVE THE QUEEN!

COMMUNITY WELFARE SERVICES ACT 1978, No. 9248
DATE OF COMING INTO OPERATION

PROCLAMATION

By His Excellency the Governor of the State of Victoria and its Dependencies in the Commonwealth of Australia, &c., &c., &c.

Whereas by an Act of Parliament of the State of Victoria passed in the twenty-seventh year of the reign of her Majesty, Queen Elizabeth the Second, Queen of Australia, entitled the *Community Welfare Services Act 1978, No. 9248*, it is amongst other things enacted that the several provisions of the said Act shall come into operation on the day or respective days to be fixed by Proclamation or successive Proclamations of the Governor in Council published in the *Government Gazette*.

Now, therefore, I, the Governor of the State of Victoria in the Commonwealth of Australia, by and with the advice of the Executive Council of the said State, do by this my Proclamation fix Thursday, 15 May 1980, as the day on which sub-section (3) of Section 7; Section 12 and Section 30 of the *Community Welfare Services Act 1978, No. 9248*, shall come into operation.

Given under my Hand and the Seal of the State of Victoria aforesaid, at Melbourne, this thirteenth day of May, in the year of our Lord One thousand nine hundred and eighty, and in the twenty-ninth year of the reign of Her Majesty Elizabeth the Second, Queen of Australia.

(L.S.) HENRY WINNEKE

By His Excellency's Command

WALTER JONA
Minister for Community Welfare Services

GOD SAVE THE QUEEN!

Industrial Training Act 1975

VARIATION OF PROCLAMATION OF THE SCREEN
PRINTING STENCIL PREPARATION TRADE AS AN
APPRENTICESHIP TRADE

PROCLAMATION

By His Excellency the Governor of the State of Victoria and its Dependencies in the Commonwealth of Australia, &c., &c., &c.

Whereas Section 19 of the *Industrial Training Act 1975* provides, *inter alia*, that after the Minister has taken into consideration any recommendation made by the Industrial Training Commission the Governor in Council, for the purposes of the said Act, may from time to time by Proclamation proclaim any trades to be apprenticeship trades and that the Governor in Council (whether with or without any recommendation of the said Commission) may by Proclamation at any time revoke, amend or vary any such Proclamation.

And whereas by Proclamation on 9 December 1958 the trade of Screen Printing Stencil Preparation was proclaimed to be an apprenticeship trade in so far as it is carried on in the Metropolitan District, the Cities of Ballarat, Bendigo, Geelong, Geelong West, Newtown and Chilwell, and the Boroughs of Eaglehawk and Sebastopol but excluding daily newspaper offices in Ballarat, Bendigo and Geelong.

And whereas the Industrial Training Commission of Victoria has recommended to the Minister that the said proclamation be varied in the manner following.

And whereas the Minister has taken the said recommendation into consideration.

Now therefore, I, the Governor of the State of Victoria in the Commonwealth of Australia, by and with the advice of the Executive Council of the said State, do by this my Proclamation vary the aforesaid Proclamation by deleting therefrom the words, "as carried on in the Metropolitan District, the Cities of Ballarat, Bendigo, Geelong, Geelong

West, Newtown and Chilwell, and the Boroughs of Eaglehawk and Sebastopol but excluding daily newspaper offices in Ballarat, Bendigo and Geelong" in so far as they apply to the trade of Screen Printing Stencil Preparation.

Given under my Hand and the Seal of the State of Victoria aforesaid, at Melbourne, this sixth day of May, in the year of our Lord, One thousand nine hundred and eighty, and in the twenty-ninth year of the reign of Her Majesty Elizabeth the Second, by the Grace of God, Queen of Australia and Her other Realms and Territories, Head of the Commonwealth.

(L.S.) HENRY WINNEKE

By His Excellency's Command

J. H. RAMSAY
Minister of Labour and Industry

GOD SAVE THE QUEEN!

GOVERNMENT NOTICES

Victoria

LOCAL GOVERNMENT DEPARTMENT

ORDER CONFIRMED—SHIRE OF ORBOST

The Minister of the Crown administering the *Local Government Act 1958*, on 5 May 1980 confirmed the Order hereinafter referred to in pursuance of section 514 of the said Act, namely:

An Order of the Council of the Shire of Orbost made on 14 March 1980 directing the compulsory taking of the land described in Certificate of Title Volume 3293 Folio 591 for the purpose of providing a place of public resort and recreation and an off-street parking area.

D. G. CROZIER
Minister for Local Government

Local Government Department
Melbourne (80/1485)

Local Government Act 1958

NOTICE OF CONFIRMATION OF AN ORDER OF THE COUNCIL OF THE CITY OF MELBOURNE ADOPTING A PROPOSAL FOR THE CLOSURE OF A STREET OR ROAD TO THROUGH TRAFFIC

Pursuant to the provisions of section 539c of the *Local Government Act 1958*, the Governor in Council on 6 May 1980 confirmed an Order of the Council of the City of Melbourne made on 29 October 1979 adopting a proposal for the closure of Robertson Street, Kensington to through traffic by the erection of a barrier in Robertson Street at the eastern building line of Barnett Street.

TOM FORRISTAL
Clerk of the Executive Council

Local Government Department
Melbourne (80/0248)

Local Government Act 1958

NOTICE OF CONFIRMATION OF AN ORDER OF THE COUNCIL OF THE CITY OF MELBOURNE ADOPTING A PROPOSAL FOR THE CLOSURE OF STREETS OR ROADS TO THROUGH TRAFFIC

Pursuant to the provisions of section 539c of the *Local Government Act 1958*, the Governor in Council on 6 May 1980 confirmed an Order of the Council of the City of Melbourne made on 29 October 1979 adopting a proposal for the closure of Hardiman and Albemarle Streets, Kensington to through traffic by the erection of a barrier in Hardiman Street on the western building line of Albemarle Street, and by the erection of a barrier in Albemarle Street at the southern building line of Hardiman Street.

TOM FORRISTAL
Clerk of the Executive Council

**SHIRE OF TALLANGATTA
ROAD DEVIATION ORDER**

Pursuant to the provisions of sections 522 and 526 of the Local Government Act 1958 the Council of the Shire of Tallangatta hereby directs that the land in the Parish of Tatonga indicated by hatching on the diagram hereunder which has been purchased taken or acquired by it, shall be a public highway on and from the date of publication of this Order in the Government Gazette and declares that such land shall be a public highway in lieu of the land indicated by crosshatching on the said diagram.

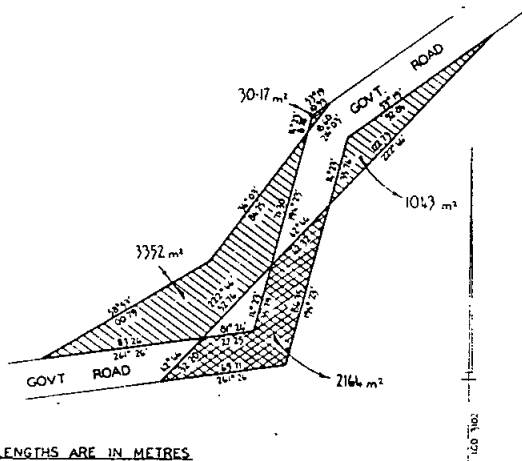

LENGTHS ARE IN METRES

The common seal of the President, Councillors and Ratepayers of the Shire of Tallangatta was hereunto affixed, 21 January 1980—

(SEAL) J. H. HARVEY, President
D. F. KELLY, Councillor
I. M. BOWMAN, Secretary

Confirmed by the Governor in Council, 6 May 1980—
TOM FORRISTAL, Clerk of the Executive Council

LAND SETTLEMENT ACT 1959

Notice is hereby given, pursuant to section 5A (4) of the Land Settlement Act 1959, No. 6534, that the land described in the Schedule hereunder is available for purchase and any person willing to enter into a Contract of Sale in respect of the land or part thereof, is invited to make an offer to the Rural Finance Commission.

SCHEDULE

Heytesbury Settlement Project

Lot No.	Hectares (All subject to survey)
1	47.3
2	59.2
3	80.7
4	47.7
5	132.0
6	244.0
7	55.5
8	55.5

The land is all suited to grazing. It is situated approximately 90 km east of Warrnambool and 80 km south-west of Colac.

Terms of Sale

If required, Rural Finance Commission finance is available on the basis of a preliminary deposit of \$5000 or not less than 10% of the purchase price, whichever is the greater, payable on signing of the contract, a further sum to bring the total paid to 40% of the purchase price, payable on or before possession, with the balance repay-

able by instalments of 11.5% per annum, including interest at 10.5% per annum, with the balance then owing payable on 1 August 1990.

Tenders may be lodged for either:

- each separate lot; or
- any combination of lots.

Preference may be given to those tenderers who:

- Are bona fide farmers who wish to purchase extra land to work in conjunction with an existing farming enterprise.
- Have suitable experience and wish to purchase adjoining lots to form a viable farming enterprise which they will personally work.
- When tendering for more than one lot, combine adjoining lots.

Further Particulars

Brochures setting out full details of the land offered will be available from the following Commission offices where a draft Contract of Sale will also be available for inspection:

- 325 Collins Street, Melbourne 3000. (03) 61 3771.
- T. & G. Building, Liebig Street, Warrnambool. (055) 62 2779.
- Tomahawk Creek Road, Simpson. (055) 94 3222.
- On-site office situated on the Boulevard Road, 300 metres north-west of the Great Ocean Road.

Local Estate Agents will also have copies of the brochure available.

Licensed Estate Agents' participation is invited. A fee equal to 50% of scale commission will be paid to agents introducing the successful tendered on each or any lot in writing provided that the letter of introduction is attached to the tender and the tenderer signs a binding contract for the purchase of land.

Properties are open for inspection from Monday, 19 May 1980, weekends inclusive, and tender forms are available only from a Commission representative at its mobile office situated on the Boulevard Road, 300 metres north-west of the Great Ocean Road, between the hours of 10 a.m. and 4 p.m. each day during the inspection period.

By prior arrangement, the Commission will assist prospective purchasers with their initial inspection of the area.

Tenders to be lodged with the Secretary, Rural Finance Commission, 325 Collins Street, Melbourne, by 12 noon, Friday, 6 June 1980, are to be accompanied by an initial deposit of \$5000.

NOTE—Additional finance for development may be available to approved successful tenderers whose tender is accepted for a number of lots which form a viable farming enterprise. Details of extra finance, if any, are to be finalised with the Commission's Chief Loans Officer at the above address, prior to lodging the tender.

G. MCG. BAKER, Deputy Secretary
Rural Finance Commission

FARM PRODUCE MERCHANTS AND COMMISSION AGENTS ACT 1965 (No. 7274)

Notice is hereby given that two Farm Produce Merchant's licences have been issued during April 1980 as listed hereunder.

Name; Principal Place of Business

Marshall's Farm Foods, Melbourne Wholesale Fruit and Vegetable Market, Footscray Road, Footscray, 3011.
Trewick, W., and Co., Stores 53-56 Melbourne Wholesale Fruit and Vegetable Market, Footscray Road, Footscray, 3011.

In accordance with the above Act, the said Merchants have paid the prescribed contribution to the Farm Produce Merchants and Commission Agents Guarantee Fund. These licences, unless earlier surrendered or cancelled, shall continue in force until 30 June 1980.

D. F. SMITH
Director General of Agriculture

Transport Regulation Act
TRANSPORT REGULATION BOARD

HEARING OF APPLICATIONS

Notice is hereby given that the following applications will be considered by the Transport Regulation Board on 3 June 1980.

L. C. DYSON'S BUS SERVICE PTY. LTD., Reservoir. Application to license one commercial passenger vehicle with seating capacity for 41 persons to operate in substitution for but not in addition to licences C.O.72, C.O.209, C.O.211, C.O.562, C.O.758, C.O.1034, C.O.1098 and C.O.1234 which authorise operations on Route 562 (Regent-Kinglake) and T.S.1320 and T.S.1710 which authorise two Education Department contract services between Kinglake and Whittlesea.

ARMSTRONG, I. R. & J. I., Mt. Eliza. Application for two special purpose vehicle licences in respect of a 1934 Rolls Royce sedan and a 1922 Rugby Tourer each with seating capacities for 4 persons to operate from 13 Meadow Lane, Mt. Eliza for the carriage of passengers for:—(a) Wedding Parties; and (b) Other purposes requiring the use of vintage cars as an essential feature. This application replaces an application which appeared in the *Victoria Government Gazette* No. 33, dated 7 May 1980.

MANSFIELD PRIMARY SCHOOL, Mansfield. Application to license one commercial passenger vehicle with seating capacity for eighteen persons to operate as follows: (a) For the carriage of Mansfield Primary School children, free of charge, for return journeys of up to 150 kilometres. A charge of 10 cents per kilometre to be charged for the hire of the vehicle for any distance in excess of 150 kilometres per return journey and apportioned equally between children using the vehicle at the time. (b) For hire to schools at Merrijig, Jamieson, Bonnie Doon, Yarck and Merton for their own use of the vehicle at a rate of 10 cents per kilometre. All hirings to commence from the Mansfield Primary School.

PARK, B. T. & J. M., Lake Bolac. Application to license one commercial passenger vehicle with seating capacity for 35 persons to operate in substitution for but not in addition to an existing T.S. licence in the name of the applicants.

NOTE—No charter rights are sought in this application.

SARATSIOTIS, D., Northcote. Application to license one commercial passenger vehicle with seating capacity for twelve persons to operate for the carriage of students from the Northcote, Thornbury and Preston areas to Greek language school classes at the Aristotle Greek School in Tyler Street, Preston under contract to the school.

WARRNAMBOOL BUS LINES PTY. LTD., Warrnambool. Application to license one commercial passenger vehicle with seating capacity for 49 persons to operate for the carriage of students on an Education Department contract service between Panmure and Warrnambool.

NOTE—No charter rights are sought in this application.

Application by the persons listed hereunder for one metropolitan taxi licence to be issued subject to the cancellation of each suburban taxi licence shown.

BELL, E. A., Dixons Creek; S.T.8040.
CHIODO, A. & M., Reservoir; S.T.7907.
CRANSTON, W. G., Lower Templestowe; S.T.7542.
KERSHAW, F. & E., Werribee; S.T.6266.
KLEIMAN, M. E. P., Moorabbin; S.T.6320.
MCBLANE, R. J., Mitcham; S.T.7900.
MURPHY, W. G., St. Albans; S.T.6334.
NEWLANDS, K. J., Croydon; S.T.5577.
PAPAKYRIAKOPOULOS, N., Watsonia; S.T.6309.
REICH, F., McKinnon; S.T.7936.
REICH, F. J. & A. C., Greensborough; S.T.5887; S.T.6189; S.T.6328.

Applications for renewal of licences as shown by the persons listed hereunder to operate under the same terms and conditions.

ARGIRO, I., Mildura; C.T.527.
BERTINO, F. M., Bairnsdale; T.S.987.
BOGHADLI, J. A. & M. A., Oakleigh; M.T.5609.
BROWNRIGG, A. R. & N. A., Clifton Creek; T.S.993; T.S.992.
CAVANAGH, L. J., Daylesford; C.T.560; C.T.194.
DAVIDSON, C. C. & J. M., Bairnsdale; T.S.991.
DOUVITSAS, H., Malvern; M.T.4238.
ELLIOTT, N. R. & M. V., Hillside; T.S.989.
FISHER, I. C. & G. A., Mossface; T.S.994.
FORD, G. L. & D. L., Lakes Entrance; T.S.996.
FRANCIS, T. C. & E. M., East Bairnsdale; T.S.988.
GRAHAM, B. L., Carnie; T.S.1451.
JONES, I. M. & E. M., Lakes Entrance; T.S.995.
JURDUKIAN, H. K., East Burwood; M.T.4935.
KNAGGS, W. S. & E. G., Bairnsdale; T.S.986.
KONTOSSIS, A., East Kew; M.T.5458.
LUNDGREN, N. E., Noorinbee; T.S.732.
MCKENZIES TOURIST SERVICES PTY. LTD., Kew; T.S.1324; T.S.1325; T.S.1326; T.S.1328; T.S.1329; T.S.1332; T.S.1335; T.S.1357; T.S.1487.
MANIATIS, V., Albert Park; M.T.1827.
MIDLAND TOURS (Vic.) PTY. LTD., Reservoir; M.C.522.
RAFTERY, W., Bairnsdale; T.S.990.
RAMSDALL, J. E., PTY. LTD., Nowa Nowa; S.V.192.
STEPHENS, G. J. & J. W., Cranbourne; C.T.320.
VARVARIS, A., East Doncaster; M.T.5359.

Notice of any objections should be forwarded to reach the Secretary of the Board not later than 28 May 1980.

Applicants are advised that it will not be necessary to appear on the hearing date specified, unless advised in writing by the Board.

C. J. V. SMITH, Secretary

Corner Lygon and Princes Streets, Carlton, 3053,
Wednesday, 14 May 1980

Commercial Goods Vehicles Act

TRANSPORT REGULATION BOARD

HEARING OF APPLICATIONS

Notice is hereby given that the following applications will be considered by the Transport Regulation Board on 3 June 1980.

ACMIL LTD., 28 Freight Road, Tullamarine, 3043. One commercial goods vehicle (L/C. 7.85 tonne) to operate within an 80-km radius of own premises at Tullamarine in course of business as "Manufacturers of Quarry Tiles and Ceramic Bathroom Fittings"—own goods excluding the carriage of restricted goods, which may be specified by notice in the *Government Gazette* from time to time.

ALLAN & STUART TRANSPORT PTY. LTD., P.O. Box 263, Glen Waverley, 3150. Three commercial goods vehicles (L/C. 8.05, 8.00 and 3.45 tonne) to operate solely on behalf of H. F. Stevenson (Aust.) Pty. Ltd.: (a) Within a 40-km radius of the G.P.O. Melbourne—general goods. (b) Within an 80-km radius of the depot installation of Gas and Fuel Corporation of Victoria at Dandenong—(i) Pipes and pipe fittings, liquid petroleum gas (porta gas) and allied gas appliances for direct delivery to householders and/or (when required) to agents and also empty containers for return. (ii) The following electrical appliances solely on behalf of Gas and Fuel Corporation of Victoria—refrigerators, deep freeze units, drink dispensers, micro wave ovens, ice making machines, glass washing machines, washing machines and clothes dryers.

ATTWOOD, B. A., 6 Moonah Street, Warrnambool, 3280. One commercial goods vehicle (L/C. 1.00 and 1.00 tonne trailer) to operate: (a) Within a 40-km radius of the post office at Warrnambool—general goods. (b) Throughout the State of Victoria in the course of business as "Marine Collector"—own marine stores and old metals as defined in the *Marine Stores and Old Metals Act 1958*, No. 6303, Part 1, section (3) with the proviso that the load capacity of the prime mover and any trailer attached thereto shall not exceed 6 tonnes.

- CANNY CARRYING CO. PTY. LTD.**, Roy Street, Wangaratta, 3677. One commercial goods vehicle (to be nominated) between Melbourne and Wangaratta areas—general goods.
- CANNY CARRYING CO. PTY. LTD.**, Roy Street, Wangaratta, 3677. One commercial goods vehicle (to be nominated) from Melbourne metropolitan area to Wangaratta area—groceries, spirits and beer.
- CLUE, W. H.**, 2/9 Milne Street, Seaford, 3199. One commercial goods vehicle (L/C. 1.10 tonne) to operate throughout the State of Victoria in the course of business as "Heating and Air Conditioning Engineers"—tools of trade, spare parts and equipment required for on site servicing of heating and air conditioning equipment and heating and air conditioning equipment for specialised installation.
- COOK, E. G. L.**, 124 Waterloo Road, Trafalgar, 3824. One commercial goods vehicle (L/C. 15.00 tonne) to operate: (a) Within a 40-km radius of the post office at Trafalgar—general goods. (b) Within an 80-km radius of own quarry at Trafalgar—crushed metal, screenings, sand and replacement parts for use in own equipment; also own plant and equipment for transfer from one contract site to another within the said radius or to workshop for repair also a quantity of fuel and oil sufficient for own use in operating own plant and equipment.
- DAWSON, C.**, 36 Clive Street, West Footscray, 3012. One commercial goods vehicle (L/C. 1.60 tonne) to operate throughout the State of Victoria in the course of business as "Pest Exterminators"—tools of trade, equipment and materials incidental to the completion of own contracts.
- H. E. DEIPENAU PTY. LTD.**, 73 Victoria Street, East Brunswick, 3057. Seven commercial goods vehicles (L/C. 21.60, 11.35, 11.65, 17.15, 18.51 and 20.90 tonne) to operate from the railway station at Arden Street, North Melbourne, to places within a 40-km radius of the G.P.O. Melbourne and to plants on the Mornington Peninsula and to Broadford, Pakenham and Romsey in a specially constructed bulk tanker—cement in bulk.
- H. E. DEIPENAU PTY. LTD.**, 73 Victoria Street, East Brunswick, 3057. One commercial goods vehicle (L/C. 11.50 tonne) to operate within an 80-km radius of own branch depot at Sale and to Lakes Entrance and Foster in a specially constructed tanker unit—cement in bulk having been initially consigned by rail to Sale.
- H. E. DEIPENAU PTY. LTD.**, 73 Victoria Street, East Brunswick, 3057. Application to vary conditions of licence Nos. T.D.A.17846/34 and T.D.A.17846/37 by deleting existing conditions and adding in lieu: "From the railway siding at Arden Street, North Melbourne, to places within a 40-km radius of the G.P.O. Melbourne and to plants on the Mornington Peninsula and to Broadford, Pakenham and Romsey in a specially constructed bulk tanker—cement in bulk."
- H. E. DEIPENAU PTY. LTD.**, 73 Victoria Street, East Brunswick, 3057. Application to vary conditions of licence No. T.D.A.17846/39 (L/C. 15.20 tonne) by adding after "Sale", "and to Lakes Entrance and Foster".
- H. E. DEIPENAU PTY. LTD.**, 73 Victoria Street, East Brunswick, 3057. Application to vary conditions of licence Nos. T.D.A.17846/40 and T.D.A.17846/42 (L/C. 18.00 and 18.25 tonne) by adding after "Broadford", "Pakenham and Romsey".
- R. G. DENT & SONS PTY. LTD.**, P.O. Box 315, Warragul, 3820. One commercial goods vehicle (L/C. 1.50 tonne) to operate: (a) Within an 80-km radius of own premises at Warragul in course of business as Machinery Merchants and Agents—own goods and agency lines. (b) From places within a 40-km radius of the G.P.O. Melbourne to own premises at Warragul being an approved decentralized secondary industry (engineering)—raw materials and goods used solely in the manufacturing processes of such industry. (c) From own premises at Warragul being an approved decentralized secondary industry (engineering) to places within a 40-km radius of the G.P.O. Melbourne and to own branch premises at Bairnsdale and Korumburra—manufactured articles and products from such industry. (d) Within that part of the State of Victoria east of a north/south line drawn through Drouin for the purpose of servicing machinery and equipment—tools of trade, spare parts and materials incidental to on-site servicing.
- DUNNE, J. T.**, "Kyandra Downs", Toongabbie, 3856. One commercial goods vehicle (L/C. 8.50 tonne) to operate: (a) Within an 80-km radius of the Post Office at Toongabbie in the course of business as Primary Producer—own goods. (b) Within an 80-km radius of the post office at Toongabbie in the course of business as "Earth Moving Contractor"—own earth moving equipment including sufficient fuels and lubricants for operation of same. (c) From the forest commission at Cowwarr to various consignees situated at Korumburra and Leongatha—wooden fence posts.
- DUXBURY, J. R.**, 18 Princes Street, Traralgon, 3844. One commercial goods vehicle (L/C. 2.27 tonne) to operate: (a) From the premises of boat and trailer manufacturers and retailers situated within the metropolitan area (as defined in the *Transport Regulation Act 1958*) to own place of business at Traralgon—boats, trailers and boating equipment (including engines) for delivery to purchasers within the area specified in part (b). (b) For delivery to purchasers within that part of Victoria situated east of a north/south line drawn through the Township of Berwick and south of an east/west line drawn through the Township of Buchan—boats, trailers and boating equipment (including engines) for delivery to purchasers of same.
- NOTE—Any equipment carried in respect of any boat or trailer carried shall be limited to such equipment that is bona fide equipment for the use of the purchaser of the boat and trailer provided that the boats are being carried on a specially constructed trailer that is towed by the vehicle.
- GOLDHILL PLANT HIRE PTY. LTD.**, 45 Ricketts Road, Mt. Waverley, 3149. Three commercial goods vehicles (L/C. 0.75 tonne each) to operate throughout the State of Victoria in the course of business as Earth-moving Equipment Contractor—tools of trade, spare parts and materials for on-site servicing and maintenance of own plant and equipment.
- GOLIGHTLY, R. C.**, Switchback Road, Churchill, 3842. One commercial goods vehicle (L/C. 0.90 and 1.00 tonne trailer) to operate: (a) From consignors situated throughout the State of Victoria to own nursery at Churchill—seedlings, plants, shrubs, concrete garden ornaments, pots and up to 100 kilograms of associated nursery lines on any one load. (b) Within a 40-km radius of the post office at Churchill in the course of business as Nurseryman—own goods.
- HAWKEY, W. R.**, 8 Flood Street, Bendigo, 3550. One commercial goods vehicle (L/C. 0.55 and 1.10 tonne trailer) to operate within a 160-km radius of the post office in Bendigo but excluding any operations within a 40-km radius of the G.P.O. Melbourne in the course of business as a Builder—own tools of trade, equipment and materials necessary for completion of own contracts on behalf of the Public Works Department and others.
- HENDERSON, K. A.**, 7 Princes Highway, Trafalgar, 3824. One commercial goods vehicle (L/C. 19.00 tonne) to operate: (a) From forest landings situated within a 16-km radius of Beardsmore to the log dump at Erica—pulp logs. (b) From forest landings situated within a 40-km radius of Australian Paper Manufacturers Ltd. at Maryvale to the said mill—pulp logs. (c) From forest landings situated within a 16-km radius of the Post Office at Nayook to the Australian Paper Manufacturers Ltd. at Maryvale—pulp logs.
- KILPATRICK GREEN PTY. LTD.**, 33 Slevin Street, North Geelong, 3215. One commercial goods vehicle (L/C. 1.36 tonne) to operate within an 80-km radius of own branch premises in the City of Geelong in the course of business as Electrical Engineering Contractors—tools of trade; spare parts and small quantities of materials not exceeding 0.20 tonnes in weight incidental to own contracts.
- LAWSON, J. L.**, McMillan Street, Lucknow, 3875. One commercial goods vehicle (L/C. 2.90 tonne) to operate within that part of the State of Victoria east of a north/south line drawn through the township of Maffra and south of an east/west line drawn through

- the township of Wulgulmerang—gas cylinders and cylinders for refilling from Gas and Fuel Depot at Bairnsdale.
- LEO'S DAILY FREIGHT SERVICE PTY. LTD.**, 313 Maude Street, Shepparton, 3630. One commercial goods vehicle (L/C. 2.05 tonne) to operate: (a) Within a 40-km radius of Shepparton—general goods. (b) From Shepparton to Cobram via the towns of Katunga, Strathmerton, Yarraweayah and Katamatite—general goods.
- MACGREGOR CARGO HANDLING PTY. LTD.**, 195 Rouse Street, Port Melbourne, 3207. One commercial goods vehicle (L/C. 1.00 tonne) to operate throughout the State of Victoria in the course of business as Instrument Engineers—tools of trade, spare parts and materials incidental to the on-site servicing of industrial instruments.
- MALLISONS BUILDING SUPPLIES PTY. LTD.**, Lot 2, Osburn Street, Wodonga, 3690. One commercial goods vehicle (L/C. 6.90 tonne) to operate within an 80-km radius of own branch premises at Wodonga in course of business as Building Supplies—own goods.
- O'CONNOR, J. W.**, Willung South, 3844. One commercial goods vehicle (L/C. 9.20 and 8.00 tonne trailer) to operate: (a) From own pits at Merriman's Creek, Longford, Yanakie or Bairnsdale to consignees within an 80-km radius of each particular pit—own bulk lime. (b) Within the area as prescribed in paragraph (a) above in the course of business as Lime Contractor—own equipment. (c) From the premises of the State Electricity Commission of Victoria at Morwell to the premises of Murray Goulburn Co-op. Ltd. at Yarram—briquettes in bulk. (d) Within a 40-km radius of the post office at Carrajung—general goods. (e) From the sawmill at A.P.M. Wood Products Pty. Ltd. at Morwell to consignees situated within a 64-km radius of such premises—sawmill waste.
- PASA, R.**, 616 Drummond Street, North Carlton, 3054. Application to vary conditions of licence No. D.A.53766/1 (L/C. 15.40 tonne) by deleting present conditions and adding in lieu: (a) From pits at Bacchus Marsh and in the You Yangs to the premises of Barro Group Pty. Ltd. at Footscray on behalf of the said company—quarry materials and sand. (b) From the premises of Barro Group Pty. Ltd. at Footscray to plants of the said company within a 40-km radius of Footscray—quarry materials and sand.
- QUEENSBRIDGE MOTORS PTY. LTD.**, 359 Plummer Street, Port Melbourne, 3027. One commercial goods vehicle (L/C. 2.95 tonne) to operate throughout the State of Victoria for the purposes of on site servicing and maintenance of agricultural machinery and associated equipment—tools of trade, spare parts and equipment required for on site servicing of such machinery and equipment.
- R. E. N. MACHINERY PTY. LTD.**, Normanby Street, Warragul, 3820. One commercial goods vehicle (L/C. 9.45 tonne) to operate: (a) Within an 80-km radius of the post office at Warragul in the course of business as Agricultural Machinery Sales and Service—new and used agricultural machinery and equipment.
- NOTE—All new machinery and equipment to be initially consigned by rail to Warragul.
- (b) Within an 80-km radius of the post office at Warragul in the course of business as Agricultural Machinery Sales and Service for the purpose of servicing and repairing agricultural machinery—own tools of trade, spare parts and materials incidental to the repair of servicing on site.
- NOTE—All such materials and spare parts to be initially consigned by rail to Warragul.
- RADFORD, K. R.**, Dodemaides Road, Trafalgar, 3824. One commercial goods vehicle (L/C. 20.15 tonne) to operate: (a) From forest landings situated within a 16-km radius of Beardsmore to the log dump at Erica—pulp logs. (b) From forest landings situated within a 40-km radius of Australian Paper Manufacturers Ltd. at Maryvale to the said mill—pulp logs. (c) From forest landings situated within a 16-km radius of the post office at Nayook to the Australian Paper Manufacturers Ltd. at Maryvale—pulp logs.
- SHAND, R. H.**, 42 George Street, Morwell, 3840. One commercial goods vehicle (L/C. 1.00 tonne) to operate within that part of the State of Victoria situated south of an east/west line drawn through the Township of Lindenow east of a north/south line drawn through Pakenham and west of a north/south line drawn through Rosedale in the course of business as Sewing Machine Sales and Service—uncrated new sewing machines, sewing machines for repair or having been repaired, tools of trade, spare parts and materials incidental thereto and the ability to return any damaged or faulty machines to the distributor.
- STEVENSON, H. F.**, AUST. PTY. LTD., P.O. Box 263, Glen Waverley, 3153. Three commercial goods vehicles (L/C. 2.95, 2.60 and 3.00 tonne) to operate: (a) Within a 40-km radius of the G.P.O. Melbourne—general goods. (b) Within an 80-km radius of the depot installation of Gas and Fuel Corporation of Victoria at Dandenong. (i) Pipes and pipe fittings, liquid petroleum gas (Porta Gas) and allied gas appliances for direct delivery to householders and/or (when required) to agents and also empty containers for return. (ii) The following electrical appliances solely on behalf of the Gas and Fuel Corporation of Victoria—refrigerators, deep freeze units, drink dispensers, micro wave ovens, ice making machines, glass washing machines, washing machines and clothes dryer.
- TENNANT, J. L.**, 759 Plenty Road, Reservoir, 3073. Application to vary conditions of licence No. D.A.26547 by deleting "Northcote Brick Co. Pty. Ltd. at Northcote" and adding in lieu "Brick and Pipe Industries Ltd. at Craigieburn".
- TONG, J.**, 18 Samuel Drive, Campbellfield, 3061. One commercial goods vehicle (L/C. 11.81 tonne) to operate within a 112-km radius of Calsil Ltd. at Ardeer on behalf of the said company—bricks.

RENEWALS

- Applications for renewal of licences as shown by persons listed hereunder to operate under the same terms and conditions from the expiry shown in each case.
- ATHANASIAS, I.**, 283 Canterbury Road, Bayswater, 3153; D.A.61710/1; 5 June 1980; 6.45 tonne.
- BROUGHTON, E. R.**, 9 Anderson Street, Euroa, 3666; D.A.732; 30 June 1980; 5.60 tonne.
- BYRON, F. P.**, 6 Grauers Road, Allansford, 3277; D.A.52281; 1 June 1980; 0.75 tonne.
- CAMPBELLS TRANSPORT PTY. LTD.**, 905 Nepean Highway, Mornington, 3931; D.A.62859/2; 6 June 1980; 7.05 tonne; D.A.65485/2; 6 June 1980; 1.25 tonne; D.A.65485/8; 2 June 1980; 8.95 tonne.
- CITY BRICK PTY. LTD.**, 124 Camberwell Road, East Hawthorn, 3123; D.A.64393/10; 27 June 1980; 6.70 tonne.
- CONCRETE TESTING PTY. LTD.**, 33 Cremorne Street, Richmond, 3121; D.A.62194; 28 July 1980; 0.45 tonne.
- DRAFFIN BROS. PTY. LTD.**, Mountain Highway, Bayswater, 3153; D.A.27827/6; 11 July 80; 0.50 tonne.
- EUCLID TRUCKING CO. PTY. LTD.**, 22 Dynon Road, South Kensington, 3031; D.A.49715/8; 27 June 1980; 2.70 tonne.
- FITZPATRICK, P. J.**, 16 Victoria Street, Numurkah, 3636; D.A.62761/3; 31 July 1980; 7.95 tonne; D.A.62761/4; 31 July 1980; 8.05 tonne.
- FLEINER, W. F.**, 45 Railway Place, Coburg, 3058; D.A.26907; 16 July 1980; 6.85 tonne.
- FURMAN, S.**, 55 Aileen Avenue, South Caulfield, 3162; D.A.52530; 16 June 1980; 1.05 tonne.
- GAS & FUEL CO. OF VICTORIA LTD.**, 171 Flinders Street, Melbourne, 3000; D.A.49393/33; 27 July 1980; 0.70 tonne; D.A.49393/62; 25 July 1980; 0.85 tonne.
- GASKIN, T. H.**, R.M.B. 1022 Midland Highway, Mooroopna, 3629; D.A.61935; 15 July 1980; 1.50 tonne and 0.40 tonne trailer.
- GLADMAN, R.**, Muntzs Road, Woodend, 3442; D.T.1668; 3 June 1980; 17.00 tonne.
- ALF HANNAFORD & CO. PTY. LTD.**, 64 East Avenue, Beverley, S.A., 5009; D.A.1232/41; 18 June 1980; seed grader.
- HANSEN & YUNCKEN PTY. LTD.**, 110 Church Street, Richmond, 3121; T.D.A.63622; 7 December 1979; 6.20 tonne; T.D.A.63622/1; 7 December 1979; 10.75 tonne; T.D.A.63622/2; 7 December 1979; 4.85 tonne.
- LEO HEMINGWAY & PICKETT PTY. LTD.**, 330 Sydney Road, Brunswick, 3056; D.A.39955/61; 30 June 1980; 1.05 tonne; D.A.39955/36; 30 June 1980; 1.95 tonne; D.A.39955/32; 30 June 1980; 2.05 tonne; D.A.39955/34; 30 June 1980; 1.90 tonne.

HERBERT, E. J., 69 Hickford Street, Reservoir, 3073; D.A.67593; 6 June 1980; 8.10 tonne.

HUME & ISER PTY. LTD., 32 Charleston Road, Bendigo, 3550; D.A.65371; 26 June 1980; 0.50 tonne.

J. C. HUTTON PTY. LTD., 60 Oakover Road, Preston, 3072; D.A.48355/27; 8 July 1980; 1.80 tonne.

RAY JACKSON PTY. LTD., Sandhurst Road, California Gully, 3556; D.A.65964; 1 June 1980; 1.00 tonne.

JCS, L., 8 Lisburn Street, Shepparton, 3630; D.A.60089/5; 17 July 1980; 0.75 tonne.

JENNINGS INDUSTRIES LTD., 690 Springvale Road, Mulgrave, 3170; D.A.37756/13; 7 July 1980; 1.30 tonne; D.A.37756/14; 7 July 1980; 1.30 tonne.

K. M. M. PTY. LTD., 461 Bourke Street, Melbourne, 3000; D.A.63895/22; 11 June 1980; 10.90 tonne.

KAISER, E., 25 Errington Road, St. Albans, 3021; D.A.61938; 15 July 1980; 0.50 tonne.

KENNEDY, B. M., 40 Francis Street, Belmont, 3216; D.A.26709; 9 July 1980; 0.50 tonne.

LEISURE & ALLIED INDUSTRIES (1973) PTY. LTD., 202 Gillies Street, Ballarat, 3350; D.A.54946/1; 13 June 1980; 0.50 tonne.

MULQUEEN PTY. LTD., 130 Burwood Road, Burwood, 3125; D.A.3594/10; 26 July 1980; 0.80 tonne.

MYER SOUTHERN STORES LTD., 38 Pall Mall, Bendigo, 3550; D.A.61148/36; 24 July 1980; 2.65 tonne.

JOHN McGRATH TRAILERS PTY. LTD., 225 Brunswick Road, Brunswick, 3056; T.D.A.65455; 31 July 1980; 1.30 tonne.

N.C.R. AUSTRALIA PTY. LTD., 23/47 Villiers Street, North Melbourne, 3051; D.A.1707/74; 26 July 1980; 0.80 tonne; D.A.1707/66; 26 July 1980; 0.75 tonne; D.A.1707/82; 26 July 1980; 0.70 tonne; D.A.1707/77; 26 July 1980; 0.75 tonne.

NADENBOUSCH, I. R., Tonimbuk via Bunyip, 3815; D.A.62550/1; 26 July 1980; 8.55 tonne.

THE NESTLE COMPANY (AUST.) LTD., Henderson Road, Tongala, 3621; D.A.31378/70; 7 July 1980; 19.95 tonne; D.A.31378/71; 7 July 1980; 20.12 tonne.

NORRIS, J. R., 173 Grant Street, Alexandra, 3714; D.A.64079/1; 18 June 1980; 8.23 tonne.

PASA, R., 616 Drummond Street, North Carlton, 3053; D.A.53766/1; 26 June 1980; 15.40 tonne.

PRIOR, L., Willung South, 3844; D.A.68500; 13 June 1980; 3.00 tonne.

GEO. RAWLINSON PTY. LTD., 215 Nelson Place, Williamstown, 3016; D.A.35099/3; 2 July 1980; 0.45 tonne.

K. P. SEIDEL PTY. LTD., 104 Leeds Road, Mount Waverley, 3149; D.A.25786; 9 July 1980; 2.00 tonne.

SOMERTON, A. J., Gisborne Road, Bacchus Marsh, 3340; D.A.60722/1; 5 June 1980; 5.78 tonne.

SOUTHERN PENINSULA TRANSPORT SERVICE PTY. LTD., 905 Nepean Highway, Mornington, 3931; D.A.2075/2; 23 June 1980; 13.00 tonne; D.A.2075/1; 23 June 1980; 14.90 tonne.

STEFOS, E., 10 Queen Street, Williamstown, 3016; D.A.65357/1; 26 June 1980; 1.90 tonne.

TINETTI, D. R., 41 Medway Road, Craigieburn, 3064; D.A.65457; 31 July 1980; 13.05 tonne.

TORPY, L., 48 Danin Street, Pascoe Vale, 3044; D.A.65917; 2 July 1980; 16.05 tonne.

WEIRE, G. D., 11 Pohlman Street, Romsey, 3434; D.A.2263/2; 12 June 1980; 7.95 tonne.

WILLIAMSON, D. H., 50 Kalimna Street, Carrum, 3197; D.A.66179; 16 July 1980; crane and 2.00 tonne trailer.

WILSON, D. K., 73 Willis Street, Hampton, 3188; D.A.65368; 26 June 1980; 0.70 tonne.

TOW TRUCKS

CIANCIO, P., 6 Nelson Street, Glenroy, 3046; D.A.69604; 11 July 1980; 1.70 tonne.

KERRIGAN, T., 315 Whitehorse Road, Balwyn, 3103; D.A.41847/3; 16 December 1979; 2.15 tonne.

SHEPARD, P. J., 117 Evans Street, Sunbury, 3429; D.A.65075/1; 29 July 1980; 2.40 tonne.

STONE, M. P., 768 Mountain Highway, Bayswater, 3153; D.A.66396/3; 7 July 1980; 2.20 tonne.

Notice of any objection should be forwarded to reach the Secretary of the Board not later than 28 May 1980.

Applicants are advised that it will not be necessary to appear on the hearing date specified above, unless advised in writing by the Board.

C. J. V. SMITH, Secretary
Corner Lygon and Princes Streets, Carlton, 3053,
Wednesday, 14 May 1980

NOTICE TO MARINERS

[No. 21 OF 1980]

AUSTRALIA—VICTORIA

PORT FAIRY AND WARRNAMBOOL

Navigation and Tide Signals Discontinued

The Navigation and Tide Signals for the Port of Port Fairy and the Navigation Signals for the Port of Warrnambool have been discontinued.

Publications Affected—Sailing Directions, Victoria 1970 Pages 86, 87 and 99.

A. J. WAGGLEN, Port Officer

Public Works Department
Ports and Harbors Division
168 Exhibition Street
Melbourne 3000, 6 May 1980

Co-operation Act 1958

2ND GREENSBOROUGH BOY SCOUT CO-OPERATIVE LIMITED

BERWICK STATE SCHOOL CO-OPERATIVE LIMITED

LARA BOWLING CLUB CO-OPERATIVE LIMITED

1ST JACANA BOY SCOUT CO-OPERATIVE LIMITED

BAIRNSDALE WEST STATE SCHOOL CO-OPERATIVE LIMITED

M.M.Y.C. CO-OPERATIVE LIMITED

BELLEVUE PRE-SCHOOL CENTRE CO-OPERATIVE LIMITED

NOTICE OF DISSOLUTION OF SOCIETIES

Notice is hereby given that I have this day registered the dissolution of the above-named societies and cancelled their registration under the above-named Act.

Dated at Melbourne 29 April 1980

J. W. BLACKMAN
Acting Deputy Registrar

Co-operation Act 1958

HEIDELBERG DISTRICT BASKETBALL CO-OPERATIVE LIMITED

Notice is hereby given in pursuance of section 78 (7) of the Co-operation Act 1958, and section 308 (2) of the Companies Act 1961 that, at the expiration of three months from the date hereof, the name of the aforementioned society will, unless cause is shown to the contrary, be struck off the register and the society will be dissolved.

Dated 30 April 1980

J. W. BLACKMAN
Acting Deputy Registrar

Co-operation Act 1958

NORTHVIEW TENNIS CLUB CO-OPERATIVE LIMITED

Notice is hereby given in pursuance of section 78 (7) of the Co-operation Act 1958 and section 308 (2) of the Companies Act 1961 that, at the expiration of three months from the date hereof, the name of the aforementioned society will, unless cause is shown to the contrary, be struck off the register and the society will be dissolved.

Dated 5 May 1980

J. W. BLACKMAN
Acting Deputy Registrar

Co-operation Act 1958

3EA ETHNIC BROADCASTERS (VIC.) CO-OPERATIVE LIMITED

Notice is hereby given in pursuance of section 78 (7) of the Co-operation Act 1958 and section 308 (2) of the Companies Act 1961 that, at the expiration of three months from the date hereof, the name of the aforementioned society will, unless cause is shown to the contrary, be struck off the register and the society will be dissolved.

Dated 1 May 1980

J. W. BLACKMAN
Acting Deputy Registrar

PRIVATE AGENTS—continued

Full Name of Applicant*	Place of Abode of Applicant or Nominee	Name of Firm or Corporation	Address for Registration	Type of Licence	Date of Hearing
MAGISTRATES' COURT, MOONEE PONDS					
Bradley, Maureen	2 Bourke St, West Essendon		2 Bourke St, West Essendon	Process Server	30.5.80
" "	" "		" "	Inquiry Agent	"
Dated at Moonee Ponds 6 May 1980 M. F. MOLONEY, Clerk of the Magistrates' Court					
MAGISTRATES' COURT, CAMPERDOWN					
Adamson, Richard Allan	26 Officer St, Mortlake		36 McKinnon St, Terang	Watchman	29.5.80
Dated at Camperdown 6 May 1980 J. G. SHIELDS, Clerk of the Magistrates' Court					
MAGISTRATES' COURT, ELSTERNWICK					
Graham, Bryan Damien	Don Rd, Launching Place		Don Rd, Launching Place	Inquiry Agent	3.6.80
Dated at Elsternwick 7 May 1980 G. V. FITZPATRICK, Clerk of the Magistrates' Court					
MAGISTRATES' COURT, SOUTH MELBOURNE					
Joseph, Ivan	8 Fernberg Pl, West Melton	T.N.T. Group 4 Total Security	425 St. Kilda Rd, Melbourne	Watchman	4.6.80
Dated at South Melbourne 7 May 1980 V. J. ARDLIE, Clerk of the Magistrates' Court					
MAGISTRATES' COURT, FOOTSCRAY					
Veitch, Graham Thomas	12 Hilbert Rd, Airport West	Mayne Nickless Ltd., (Armaguard)	390 St. Kilda Rd, Melbourne	Watchman	11.6.80
Dated at Footscray 7 May 1980 J. T. FERGUSON, Clerk of the Magistrates' Court					
MAGISTRATES' COURT, BALLARAT					
Teusner, Clive Langdon	Talbot Rd, Clunes	Ray Golding Security Services	423 Cobden St, Ballarat	Watchman	28.5.80
Dated at Ballarat 7 May 1980 D. L. CROFT, Clerk of the Magistrates' Court					
MAGISTRATES' COURT, BALLARAT					
Jeffrey, Frederick John	41 Stamford St, Wendouree		423 Cobden St, Ballarat	Watchman	29.5.80
Dated at Ballarat 6 May 1980 D. L. CROFT, Clerk of the Magistrates' Court					
MAGISTRATES' COURT, SPRINGVALE					
Percy, Kenneth Clifton	11 Bimbadeen Crt, Bayswater		41 Fairview St, Springvale	Watchman	30.5.80
Dated at Springvale 6 May 1980 P. COUTTS, Clerk of the Magistrates' Court					
MAGISTRATES' COURT, COBURG					
Stringer, Mitchell Leonard	30 Arthur St, Eltham	Mayne Nickless Ltd.	390 St. Kilda Rd, Melbourne	Watchman	18.6.80
Dated at Coburg 8 May 1980 J. F. ISAACS, Clerk of the Magistrates' Court					
MAGISTRATES' COURT, SUNBURY					
Ficnerski, Robert	5 Oakley Crt, Gisborne		5 Oakley Crt, Gisborne	Guard Agent	3.6.80
Lahiff, Michael Gabin	78 Fersfield Rd, Gisborne	Regional Security Services	78 Fersfield Rd, Gisborne	Guard Agent (Firm)	"
" " "	" "	" "	" "	Guard Agent	"
Dated at Sunbury 8 May 1980 L. F. HANDLEY, Clerk of the Magistrates' Court					
MAGISTRATES' COURT, SPRINGVALE					
Boaler, Francis	18 Partridge Cres, Frankston		41 Fairview St, Springvale	Watchman	30.5.80
Dated at Springvale 9 May 1980 P. COUTTS, Clerk of the Magistrates' Court					

* Or in the case of a firm or corporation, of the Nominee

In the Supreme Court of Victoria—M12619—In the matter of the *Lotteries Gaming and Betting Act 1966*; and in the matter of an Application by Reginald George Brown Chief Inspector of Police to have the declaration that the house situated at 318 Victoria Street, Brunswick in the State of Victoria is a Common Gaming House or Place made on 27 September 1977 rescinded

BEFORE THE HONORABLE MR JUSTICE O'BRYAN (IN CHAMBERS) TUESDAY, 26 FEBRUARY 1980

This application coming on to be heard before me this day and upon hearing Mr D. Byrne of Counsel for the Applicant and Mr Dane of Counsel for Leonidas Mylonakos, Christina Mylonakos, Jim Stratigakos and Ligeri Stratigakos and the Baptist Union of Victoria and upon reading the affidavit of Reginald George Brown sworn herein 26 February 1980 and the affidavit of Leonidas Mylonakos and Jim Stratigakos sworn herein 20 February 1980 and the affidavit of Michael Reginald Francis North sworn herein 21 February 1980 and the exhibit thereto and upon hearing the evidence of Robert Hamilton given *viva voce* and upon the owners of the premises situate at 318 Victoria Street Brunswick the said Leonidas Mylonakos and Jim Stratigakos undertaking to this court both orally and in writing—

- (a) That they will do nothing to impede or prevent the Baptist Union of Victoria from taking possession of the premises pursuant to the terms of the lease of 13 December 1979.
- (b) That if the said lease should be determined for any reason whatsoever prior to 27 February 1982 they will forthwith notify this fact in writing to the officer in charge of Police at Brunswick.
- (c) That if the Baptist Union of Victoria should prior to 27 February 1982 seek their consent to sub let assign transfer or part with possession or occupation of the premises then they will require the insertion in any agreement with the proposed sub-lessee assignee transferee or possessor or occupant a covenant that such person will not use or permit the premises to be used as a common gaming house or place and they will forthwith notify the said officer in charge that such consent is sought and inform him of the identity of such person and they will not give any such consent if the said officer should within ten days of such notification give written notice of objection thereto.
- (d) That should they propose to let the premises to any person other than the Baptist Union of Victoria or to permit any such other person to enter into possession or occupation pursuant to some agreement then they will cause to be inserted in any such lease or agreement a specific covenant that any such other person will not use or permit to be used the premises for the purpose of a common gaming house or place and they will forthwith notify the said officer in charge that they propose to enter into such lease or agreement and inform him of the identity of such other person and they will not enter into any such lease or agreement if the said officer should within ten days of such notification give written notice of objection thereto.
- (e) In the event that any breach of the covenants referred to should come to their notice they will forthwith take all reasonable steps to terminate any such lease or other agreement.

I order that the declaration made by the Honorable Mr Justice Starke on 27 September 1977 pursuant to the provisions of section 51 (1) (a) of the *Lotteries Gaming and Betting Act 1966* declaring that the house or place situate at 318 Victoria Street, Brunswick is a common gaming house or place be rescinded and I direct that the said undertakings of Leonidas Mylonakos and Jim Stratigakos dated 26 February 1980 remain on the file as part of the record and I certify that this was a matter proper for the attendance of Counsel in Chambers.

N. M. O'BRYAN, J.

This Order was taken out by D. Yeaman, Crown Solicitor, 221 Queen Street, Melbourne and Solicitor for the Applicant.

Police Offences Act 1958, No. 6337
DIVISION 1A—STATE CLASSIFICATION OF
PUBLICATIONS BOARD

Take note that the State Classification of Publications Board has classified the following publications in accordance with the provisions of section 180H (1) of the *Police Offences Act 1958*.

Each publication shall be subject to the following restrictions:

- (a) it shall not be offered for sale, sold, delivered, exhibited or displayed to any person under the age of 18 years;
- (b) it shall not be made available for inspection or perusal to any person under the age of 18 years.
- (c) it shall not be exhibited or displayed in any place to which persons under the age of 18 years have access or so that it is visible from any such place;
- (d) it shall not be advertised in any manner whatsoever.

SCHEDULE OF PUBLICATIONS

Title	Distributor
Around The World	Melbourne Wholesale News-agency Pty. Ltd.
Fiesta Vol. 14 No. 5	Gordon & Gotch (A'sia) Ltd.
"French" Wife, The	Melbourne Wholesale News-agency Pty. Ltd.
Gay No. 60 (and subsequent edition)	W. J. Horne
Homo Action Nos. 4, 10, 11, 12 13 and 16	Wathen Wholesale Pty. Ltd.
Homo Special	Wathen Wholesale Pty. Ltd.
Honey	Melbourne Wholesale News-agency Pty. Ltd.
Horny Young Numbers No. 4	Harem
Hot Mouth Gini	Melbourne Wholesale News-agency Pty. Ltd.
Hot Young Chicks	Harem
Human Digest—May 1980	Gordon & Gotch (A'sia) Ltd.
Human Insight—April 1980	Gordon & Gotch (A'sia) Ltd.
Letters—May 1980	Gordon & Gotch (A'sia) Ltd.
Lydia's Lover	Venus Enterprises Pty. Ltd.
Park Lane No. 45	Claredale Holdings Pty. Ltd.
Slurp	Borderline Distributors

J. SMITH, Secretary
State Classification of Publications Board

Police Regulation Act 1958, Section 122
SALE OF UNCLAIMED MOTOR VEHICLE

An owner is required for an unregistered blue and white Triumph motor cycle, Engine No. T 120V DG 54088.

The vehicle came into the possession of Police on 12 January 1980, and if not claimed will be sold by public auction at the Brunswick Police Station, 620 Sydney Road, Brunswick, at 2 p.m. Wednesday, 28 May 1980.

S. I. MILLER
Chief Commissioner

Police Regulation Act 1958, Section 122
SALE OF UNCLAIMED MOTOR VEHICLE

An owner is required for a 1970 model blue Holden panel van, former Reg. No. QLD OHV-348, Engine No. QL 12862.

The vehicle came into the possession of Police on 11 January 1979, and if not claimed, will be sold by public auction at the Euroa Police Station, 40 Kirkland Avenue, Euroa, at 2 p.m. on Wednesday, 6 August 1980.

S. I. MILLER
Chief Commissioner

CONTRACTS ACCEPTED—(Series 1979-80)

AMENDMENTS

Schedule Number	Item Number	New Rate	Effective Date
\$			
<i>Antiseptics, Disinfectants, Deodorants and Insecticides</i>			
1/01	14	2.65*	14.4.80
* \$3 Service Fee for Orders less than \$15.			
<i>Protective Clothing, Uniforms and Safety Equipment</i>			
1/14	4-7	10.535*	1.5.80
	8-11	13.325*	
* Less 2½ per cent., 30 days.			
1/33	10, 11	List 280	10.4.80
		Less 33%	
	12	List 280	
		Less 29%	
	13-16	List 280	
		Less 32%	
	17-20	List 280	
		Less 34%	
<i>Liquid Petroleum Gas</i>			
1/52	1	284.09*	9.4.80
	2	290.00*	
	3	307.78*	
	4	318.59*	
	5	338.23*	
	6	15.86	
	7	.1557	11.4.80
	8	.1567 (Area 1)	
		.1627 (Area 2)	
		.1667 (Area 3)	
		.1707 (Area 4)	
		.1747 (Area 5)	
		.1787 (Area 6)	
		.1867 (Area 7)	
* Less \$80 Per Tonne for Household Users, Non Profit Residential Institutions and Schools			
<i>Photographic and X-Ray Equipment</i>			
1/55	14	57.50*	11.4.80
	18	492.93*	
	32	492.93*	
	111	18.15	
	112	23.48	
	270	3.27	
	274	15.85	
	296	3.02	
	297	9.41	
	320	169.91	
	321	175.48	
	322	14.06	
	323	225.18	
	324	185.43	
	325	104.93	
	326	33.26	
	327	112.98	
	328	31.31	
	329	16.60	
* Minimum Orders Unchanged.			
<i>Hand Tools (General)</i>			
1/56	17	0.70*	14.4.80
	19	17.18 (10" × 18 — 32)	
		18.22 (12" × 18 — 32)	
	44	1.04	17.4.80
	46	20.65 (500 mm)	30.4.80
		21.50 (750 mm)	
		22.35 (1000 mm)	
		23.30 (1250 mm)	
		24.55 (1500 mm)	
		25.70 (1750 mm)	
		25.85 (2000 mm)	
		27.42 (2250 mm)	
		28.30 (2500 mm)	
	47	4.21 (4")	17.4.80
		5.88 (5")	
	54	4.76	30.4.80
	55	6.56	
	56	11.17	
	57	13.87	14.4.80
	119	40.44	
	130	10.42	17.4.80
	138	6.22	14.4.80
	140	6.22	
	141	5.19	
	142	5.19	

AMENDMENTS—continued

Schedule Number	Item Number	New Rate	Effective Date
\$			
<i>Hand Tools (General)—continued</i>			
1/56	143	3.09	14.4.80
	144	3.09	
	173	0.66	
	174	2.28	
	176	0.66	
	184	0.92	
	185	0.92	
	186	0.92	
	187	1.59	
	199	3.81	
	207	12.88	
	209	7.12	17.4.80
	210	7.40	30.4.80
	211	Reg. 109	
	262	5.66	14.4.80
	263	3.39	
	266	2.77	
	267	7.35	
	306	10.32	
	322	13.79	
	348	24.27	30.4.80
	358	35.79	14.4.80
	363	0.61	14.4.80
	364	0.51	
	365	0.60	
	366	0.71	
	367	0.51	
	370	1.50	
	371	1.71	
	372	1.71	
	373	2.09	
	374	2.46	
	377	2.46	
	378	1.77	
	382	2.08	
	383	1.81	
	385	3.04	
	386	2.14	
	387	2.91	
	392	11.66	
	393	11.66	
	394	11.66	
	395	13.06	
	396	19.10	
	427	5.15	17.4.80
	428	6.63	30.4.80
	429	5.10	17.4.80
	430	5.51	
	431	2.19	
	439	5.92	30.4.80
	441	1.61	14.4.80
	442	2.25	
* Change Contractor's name to A. J. Calder			
<i>Provisions—Melbourne and Metropolitan District</i>			
2/01	127	28.18	21.4.80
	128	21.14	
<i>Provisions—Butter</i>			
2/03	1	43.22	14.4.80
	2, 3	28.11	28.4.80
	4	43.22	14.4.80
	5, 6	28.11	
	13	28.30	21.4.80
	14	28.30	
	19	28.11	28.4.80
<i>Provisions—Cheese</i>			
2/04	1	1.75	17.4.80
	2	1.91	
	3	1.91	
	4	1.90	
	5	2.045	
	6	2.045	
	7	1.75	
2/04	8	1.91	
	9	1.91	
	10	1.90	
	11	2.045	
	12	2.045	
	16	2.14	21.4.80
	23	1.75	17.4.80

CONTRACTS ACCEPTED—(Series 1979-80)
PUBLIC WORKS

His Excellency the Governor of the State of Victoria by and with the advice of the Executive Council thereof has by Order made on 6 May 1980, approved of the acceptance by the Minister of Public Works of the under-mentioned offers without public tenders being invited; viz.:

Offer of Drillers International Pty. Ltd. for Coring Project 1980 at Westernport Bay and Port Phillip Bay at Rates (estimated at \$16 500.00)—(P. & H.167384).

Offer of Liddy Classic Pty. Ltd. for supply and fixing of plasterboard at Carnegie Primary School No. 2897 for the sum of ten thousand one hundred and sixty-six dollars (\$10 166.00)—(C.G./E.34681v).

Offer of Stewart C. Combs for professional services (Architectural) at Myrtleford Consolidated School for the sum of twelve thousand dollars (\$12 000.00)—(P.N.57870p).

Offer of Smith & Osborne Holdings Pty. Ltd. for attention to burst hot water pipe at Greythorn High School for the sum of eleven thousand seven hundred and fifty-one dollars ninety cents (\$11 751.90)—(C.192592).

Offer of Macson Machine Tools Pty. Ltd. for supply of lathes to Melton Technical School for the sum of fourteen thousand seven hundred and twenty-five dollars (\$14 725.00)—S00/7247/010).

TOM FORRISTAL
Clerk of the Executive Council

At the Executive Council Chamber
Melbourne, 6 May 1980

DEPARTMENT OF MINERALS AND ENERGY

Subject to any necessary excisions, etc., it is proposed to grant the following Mining Leases:

No. 271-1; Neillie Elizabeth Leyonhjelm; 29 ha, Parish of Tullyvea.

No. 678; Australian Plaster Proprietary Limited; 192 ha, Parishes of Koonda and Wootwoara.

EXPLORATION LICENCES CANCELLED

No. 701; Dampier Mining Company Limited; 592 km², County of Bogong.

No. 702; Dampier Mining Company Limited; 660 km², County of Bogong.

SEARCH LICENCES GRANTED

No. 1462; P. J. Fiske, H. Stag; 40 ha, Parish of Butgulla.

No. 1534; R. A. Borchers, C. R. Dempsey, J. C. Kennedy, S. I. Lincoln; 40 ha, Parish of Glenlogie.

EXTRACTIVE INDUSTRY LICENCE GRANTED

No. 586; Somerset Contracting Company Pty. Ltd.; 21 ha, Parishes of Dousta Galla and Tullamarine.

EXTRACTIVE INDUSTRY LICENCE TRANSFERRED

No. 646; From Maude Quarries Proprietary Limited to Trans Sand and Services Proprietary Limited.

J. C. M. BALFOUR
Minister for Minerals and Energy

MINING LEASES DECLARED VOID

No. 527; Australian Plaster Proprietary Limited; 159 ha, Parish of Wootwoara.

No. 564; Australian Plaster Proprietary Limited; 33 ha, Parishes of Koonda and Wootwoara.

B. W. COURT
Secretary for Minerals and Energy

DEPARTMENT OF MINERALS AND ENERGY

Pipelines Act 1967, No. 7541

NOTICE

APPLICATION FOR A PERMIT TO OWN AND USE A SYSTEM OF PIPELINES

1. In accordance with the provisions of section 11 (1) of the *Pipelines Act 1967*, notice is given that an application has been received by me from the Altona Petrochemical Company Ltd. for a permit to own and use a system of pipelines for the purpose of conveying natural gas from its plant at Altona to the Petroleum Refineries (Australia) Pty. Ltd. refinery at Altona.

2. Line 1 is a proposed above ground pipeline wholly within property owned by Altona Petrochemical Company Ltd. Line 2 was laid during the early 1960's for the purpose of conveying refinery fuel gas from Petroleum Refineries (Australia) Pty. Ltd.'s refinery to the Altona Petrochemical Company Ltd. at Altona plant and subsequently was exempted from the provisions of the *Pipelines Act 1967* which came into operation in 1967. This company now desires to build Line 1 and re-activate Line 2 for the purpose of connecting the former to the Gas and Fuel Corporation of Victoria's natural gas pipeline network and consequently the provisions of the *Pipelines Act 1967* must now apply to the proposal.

The proposed routes of the pipelines comprising the system are as follows:

Line 1—A steel pipeline approximately 440 metres in length with a nominal bore of 200 mm commencing at a line valve located at the outlet of the Gas and Fuel Corporation of Victoria's metering station at the south-west corner of the intersection of 9th Street with Kororoit Creek Road on property owned by Altona Petrochemical Company Ltd. and known as Lot B, Part Subdivision 117983, Parish of Truganina, thence proceeding in a generally southerly direction above ground for approximately 440 metres to connect with Line 2 at its commencement point.

Line 2—A steel pipeline approximately 3.3 km in length with a nominal bore of 250 mm commencing near the south-western corner of the intersection of B Street and 9th Street, Altona on property owned by Altona Petrochemical Company Ltd. and known as Lot B, Part Subdivision 117983, Parish of Truganina, thence proceeding in a generally easterly direction for approximately 350 metres to a point adjacent to the boundary fence with the Melbourne-Geelong rail line on the southern side of such property, thence turning to continue in a generally north-easterly direction for approximately 150 metres parallel to the boundary fence, thence at a point adjacent to an existing box culvert under the Melbourne-Geelong rail line turning in a generally south-easterly direction to leave the Altona Petrochemical Company Ltd.'s property to enter Victorian Railways property and cross under the Melbourne-Geelong rail line to enter Part Allotment C.P. 10, thence at a point immediately adjacent to the northern boundary of such allotment, turning to continue in a generally north-easterly direction parallel to the northern boundary of such allotment, to enter an existing pipe rack owned by Altona Petrochemical Company Ltd. and within such pipe rack continue in a generally easterly then southerly direction crossing Cherry Creek, Allotment B, Section 8, Kororoit Creek Road, Allotment 15, Section 20, Parish of Truganina, Kororoit Creek, Allotment 12, Section 1, Lot 1 P.S.76412, Allotment 11; Section 1, Part Allotment A, Allotment F1 and Part Allotment F2, Section 4, Parish of Cut Paw Paw and Millers Road, to terminate at an isolating valve located approximately 30 metres east of Millers Road at a point approximately 120 metres north of Kororoit Creek Road within property owned by Petroleum Refineries (Australia) Pty. Ltd at Altona, situated on Part Allotment F2, Parish of Cut Paw Paw.

3. Plans of the proposed route of the pipeline may be inspected commencing Friday, 9 May 1980, between the hours of 10.00 a.m. and 4.00 p.m. on Mondays to Fridays (excluding public holidays) at—

- Department of Minerals and Energy, 5th Floor, 151 Flinders Street, Melbourne.
- Altona Petrochemical Company Ltd., Maidstone Street, Altona.

Additional copies of plans are not available from the Department and preliminary route plans can be seen only at Altona Petrochemical Company Ltd., Maidstone Street, Altona, 3018.

4. Any objections to the proposed route of the pipeline must be addressed to me and reach the Office of the Department no later than Friday, 20 June 1980.

7 May 1980

J. C. M. BALFOUR
Minister for Minerals and Energy

Public Service Act 1974

NOTIFICATION UNDER SECTION 60 (5)

A communication from me to Reginald Arthur Loughrey an officer of the Ministry for Police and Emergency Services was posted to his last known address on 15 April 1980.

R. L. KING
Secretary

GEELONG WATERWORKS AND SEWERAGE TRUST
TRANSFER OF LAND

His Excellency the Governor of the State of Victoria by and with the advice of the Executive Council thereof has by Order made on 6 May 1980, and pursuant to the provisions of the Water Act consented to the transfer of part of Crown Allotments A and B, Section 10, Parish of Duneed, County of Grant, as shown by red colour on the plan approved by and with this Order to the Shire of Barrabool.

TOM FORRISTAL
Clerk of the Executive Council

At the Executive Council Chamber
Melbourne, 6 May 1980

FIFTEEN MILE CREEK IMPROVEMENT TRUST
RATING BY-LAW No. 15

The Fifteen Mile Creek Improvement Trust, in pursuance and exercise of the powers conferred by the *River Improvement Act 1958*, doth hereby make the By-law following:

1. The following rates to be called the Fifteen Mile Creek Improvement District Improvement Rate, are hereby made, and shall be levied upon the occupiers or owners of all properties within the Fifteen Mile Creek Improvement District which are rateable to any municipality:

A rate of one and seven hundredths of a cent in the dollar on the net annual value of all properties in the A Division.

A rate of seventy-three hundredths of a cent in the dollar on the net annual value of all properties in the B Division.

2. In respect of all those properties within C Division, no rate is made or levied for the period beginning with 1 January 1980 and ending with 31 December 1980.

3. Provided that in no case shall the amount of rate payable per annum in respect of any property be less than two dollars (\$2.00).

4. Such rates are made and shall be levied for the period beginning with 1 January 1980 and ending with 31 December 1980 and shall be payable on 11 May 1980, at the office of the Fifteen Mile Creek Improvement Trust at Wangaratta.

5. Such person or persons as Fifteen Mile Creek Improvement Trust may from time to time appoint for the purpose shall be and is or are hereby authorised to demand, receive, collect and recover the said rate.

The foregoing By-law was made by the Fifteen Mile Creek Improvement Trust on 2 November 1979, and common seal of the said Trust was hereunto affixed 2 November 1979, in presence of—

(SEAL) H. J. YOUNGER, Chairman
L. J. WILSON, Commissioner
J. A. ROBERTS, Secretary

Approved, 30 April 1980—F. J. GRANTER, Minister of Water Supply

Drainage Areas Act 1958

SPECIAL MAINTENANCE CHARGE MADE BY THE COUNCIL OF THE SHIRE OF MINHAMITE IN RESPECT OF THE EUMERALLA DRAINAGE AREA

Notice is hereby given that on 6 May 1980 in accordance with the provisions of section 36 of the *Drainage Areas Act 1958*, the Governor in Council approved the estimate of the cost of proposed maintenance works in the Eumeralla Drainage Area submitted by the Council of the Shire of Minhamite, and the making by the Council of a Special Maintenance Charge on properties within the said Drainage Area, for the year ending 30 September 1980.

TOM FORRISTAL
Clerk of the Executive Council

Drainage Areas Act 1958

SPECIAL MAINTENANCE CHARGE MADE BY THE COUNCIL OF THE SHIRE OF SOUTH GIPPSLAND IN RESPECT OF THE YANAKIE DRAINAGE AREA

Notice is hereby given that on 6 May 1980 in accordance with the provisions of section 36 of the *Drainage Areas Act 1958*, the Governor in Council approved the estimate of the cost of proposed maintenance works in the Yanakie Drainage Area submitted by the Council of the Shire of South Gippsland and the making by the Council of Special Maintenance Charges on properties within the said Drainage Area, for the year ended 30 September 1979.

TOM FORRISTAL
Clerk of the Executive Council

Cemeteries Act 1958

SCALE OF FEES OF THE BELLARINE PUBLIC CEMETERY

In pursuance of the powers conferred upon them by the *Cemeteries Act*, the trustees of the Bellarine Public Cemetery hereby make the following scale of fees, which shall come into operation upon publication in the *Government Gazette*, and from and after such publication every scale of fees heretofore made by the said trustees shall be and is hereby rescinded to the extent to which it conflicts with this scale.

Private Graves	\$
Gravesite 2.44 m x 1.22 m	80.00
G. C. NICHOLSON, Trustee	
T. CONNOR, Trustee	
H. M. PEEL, Trustee	

Approved by the Governor in Council, 6 May 1980—
TOM FORRISTAL, Clerk of the Executive Council

Cemeteries Act 1958

SCALE OF FEES OF THE BOX HILL PUBLIC CEMETERY

In pursuance of the powers conferred upon them by the *Cemeteries Act*, the trustees of the Box Hill Public Cemetery hereby make the following scale of fees, which shall come into operation upon publication in the *Government Gazette*, and from and after such publication every scale of fees heretofore made by the said trustees shall be and is hereby rescinded to the extent to which it conflicts with this scale.

Land	\$
Land for private graves 2.44 m x 1.22 m	110.00
Sinking Charges for Private Graves	
Sinking grave 2.13 m or 2.44 m and reopening grave	160.00
R. V. COUCHE, Trustee	
K. PATTERSON, Trustee	
A. L. MCFARLANE, Trustee	

Approved by the Governor in Council, 6 May 1980—
TOM FORRISTAL, Clerk of the Executive Council

Cemeteries Act 1958
SCALE OF FEES OF THE FERNTREE GULLY
PUBLIC CEMETERY

In pursuance of the powers conferred upon them by the Cemeteries Act, the trustees of the Ferntree Gully Public Cemetery hereby make the following scale of fees, which shall come into operation upon publication in the *Government Gazette*, and from and after such publication every scale of fees heretofore made by the said trustees shall be and is hereby rescinded to the extent to which it conflicts with this scale.

<i>Private Graves</i>	\$
Land, 2.44 m x 1.22 m for monumental beam type lawn grave (including sinking)	390.00
General denominational grave (where available)	335.00
Pre-need reservation fee (all graves)	40.00
<i>Reopening Charges</i>	
Lawn section graves	190.00
All general denominational graves	180.00
<i>Oversized Graves</i>	
Oversized shaped grave, all sections (extra)	55.00
Rectangular openings (2.13 m x .684 m) (extra)	115.00
<i>General</i>	
Removal of chip top (monumental surmounted graves only)	16.00
Removal of ledger	32.00
Fee for interment on Saturday (extra)	80.00
Issue of a duplicate deed (right or burial)	8.00
Interment of ashes in a private grave	35.00
Niche in Wall of Remembrance (Columbarium)	80.00
<i>Monumental Fees</i>	
Deposit of \$16.00 to apply in respect of each individual application to erect a memorial in addition to a minimum fee of \$16.00 for monumental value costing up to \$100.00, plus \$2.00 fee for each additional \$100.00 in excess of basic amount or part thereof.	
E. L. GALE, Trustee	
M. J. READ, Trustee	
A. OWEN, Trustee	

Approved by the Governor in Council, 6 May 1980—
TOM FORRISTAL, Clerk of the Executive Council

Cemeteries Act 1958
SCALE OF FEES OF THE GYPSY POINT
PUBLIC CEMETERY

In pursuance of the powers conferred upon them by the Cemeteries Act, the trustees of the Gypsy Point Public Cemetery hereby make the following scale of fees, which shall come into operation upon publication in the *Government Gazette*, and from and after such publication every scale of fees heretofore made by the said trustees shall be and is hereby rescinded to the extent to which it conflicts with this scale.

<i>Private Graves</i>	\$
Number peg or label	10.00
<i>Sinking Charges for Private Graves</i>	
Sinking grave 1.83 m deep	60.00
N. DE GEUS, President	
A. W. TRIGGS, Trustee	
E. DE GEUS, Trustee	
L. J. STEVENS, Trustee	
A. P. PEISLEY, Secretary	

Approved by the Governor in Council, 6 May 1980—
TOM FORRISTAL, Clerk of the Executive Council

Cemeteries Act 1958
SCALE OF FEES OF THE MURRAYVILLE
PUBLIC CEMETERY

In pursuance of the powers conferred upon them by the Cemeteries Act, the trustees of the Murrayville Public Cemetery hereby make the following scale of fees, which shall come into operation upon publication in the *Government Gazette*, and from and after such publication every scale of fees heretofore made by the said trustees shall be and is hereby rescinded to the extent to which it conflicts with this scale.

<i>Public Graves</i>	\$
Interment in grave without exclusive right—stillborn child	15.00
Interment in grave without exclusive right—others	30.00
Number peg or label	6.00
<i>Private Graves</i>	
Land, 2.44 x 1.22 m	44.00
Own selection of land	10.00
<i>Sinking Charges for Private Graves</i>	
Sinking grave 1.83 m deep	66.00
Each additional 0.3 m	13.00
Sinking oversize grave (extra)	25.00
Cancellation of order to sink (if commenced)	13.00
<i>Reopening Charges</i>	
Reopening grave (no cover)	57.00
Reopening grave (with cover)	63.00
<i>Extra Charges</i>	
Interment outside prescribed hours, or on Saturdays, Sundays or Public Holidays	23.00
Interment in a private grave without due notice	23.00
<i>Miscellaneous Charges</i>	
Interment fee	20.00
Certificate of right of burial	4.00
Number plate or brick	6.00
Permission to erect a headstone or monument—5 per cent of cost with a minimum of \$8.00	
Permission to construct a brick grave or to erect any stone kerb, brick tile-work or concrete	9.00
Exhuming the remains of a body (when authorized)	100.00
Interment of ashes in a private grave	19.00
C. P. CRANE, Trustee	
S. A. WRAY, Trustee	
L. WILLERSDORF, Trustee	

Approved by the Governor in Council, 6 May 1980—
TOM FORRISTAL, Clerk of the Executive Council

Cemeteries Act 1958
SCALE OF FEES OF THE WODONGA
PUBLIC CEMETERY

In pursuance of the powers conferred upon them by the Cemeteries Act, the trustees of the Wodonga Public Cemetery hereby make the following scale of fees, which shall come into operation upon publication in the *Government Gazette*, and from and after such publication every scale of fees heretofore made by the said trustees shall be and is hereby rescinded to the extent to which it conflicts with this scale.

<i>Children's and Stillborn Area—Lawn Section</i>	\$
Land	30.00
Desk and single plaque	90.00
Digging, stillborn child	40.00
Digging, child	60.00
G. C. GEHRIG, Trustee	
F. M. HARKER, Trustee	
S. W. SCHULZ, Trustee	

Approved by the Governor in Council, 6 May 1980—
TOM FORRISTAL, Clerk of the Executive Council

Cemeteries Act 1958
SCALE OF FEES OF THE PORT FAIRY
PUBLIC CEMETERY

In pursuance of the powers conferred upon them by the Cemeteries Act, the trustees of the Port Fairy Public Cemetery hereby make the following scale of fees, which shall come into operation upon publication in the *Government Gazette*, and from and after such publication every scale of fees heretofore made by the said trustees shall be and is hereby rescinded to the extent to which it conflicts with this scale.

	\$
Land, 2.44 x 1.22 m	65.00
Sinking to 2.3 m for two burials	75.00
Sinking to 2.75 m for three burials	85.00
Reopening a grave	75.00
Certificate of right of burial	5.00
Land in children's or stillborn area	20.00
Sinking for children's or stillborn casket	20.00
Sinking for American casket (extra)	15.00
Sinking without due notice (extra)	25.00
Sinking or interment Saturday, Sunday or Public Holiday (extra)	30.00
Interment fee adult	60.00
Interment fee stillborn	15.00
Permission to erect a monument	20.00
Permission to erect a monument in children's or stillborn area	10.00
Permission to inscribe on a monument	5.00
Permission to alter an existing monument or to replace a slab	10.00
Removing a slab to permit a burial	20.00
Interment of ashes (including land)	50.00
Interment of ashes in private grave	40.00

T. E. DIGBY, Trustee
T. D. PERITT, Trustee
W. H. SHEEHAN, Trustee

Approved by the Governor in Council, 6 May 1980—
TOM FORRISTAL, Clerk of the Executive Council

Cemeteries Act 1958
SCALE OF FEES OF THE YALLOURN
PUBLIC CEMETERY

In pursuance of the powers conferred upon them by the Cemeteries Act, the trustees of the Yalourn Public Cemetery hereby make the following scale of fees, which shall come into operation upon publication in the *Government Gazette*, and from and after such publication every scale of fees heretofore made by the said trustees shall be and is hereby rescinded to the extent to which it conflicts with this scale.

	\$
<i>Lawn Section (Non-Denominational)</i>	
Bronze plaque for each interment (as supplied by the trust)	73.00

E. L. LEWIS, Trustee
T. A. CONNORS, Trustee
M. WALKER, Trustee

Approved by the Governor in Council, 6 May 1980—
TOM FORRISTAL, Clerk of the Executive Council

PUBLIC TRUSTEE ACT 1958, SECTION 17

I hereby give notice that on 30 April 1980, the Public Trustee filed elections to administer the following deceased persons' estates in accordance with section 17 of the *Public Trustee Act 1958*.

CALDWELL, CLEMENT LEWES JOHN, late of Ballarat, pensioner, died 26 October 1979.

CARR, WILLIAM, late of Mont Park, pensioner, died 12 December 1979.

COLE, MICHAEL WILLIAM, late of 11 Lindisfarne Avenue, Croydon, meter reader, died 23 February 1980.

MCNAMARA, RUBY EDNA, late of 8 Kingsford Avenue, Merlynston, married woman, died 17 February 1980.

No. 34—20690/80—2

I hereby give notice that on 5 May 1980, the Public Trustee filed elections to administer the following deceased persons' estates in accordance with section 17 of the *Public Trustee Act 1958*.

ROGERS, BRIAN LESLIE SHANE, late of Flat 36, 11 Marine Parade, St. Kilda, railway engineman, died 18 March 1980.

P. T. SPENCER
Public Trustee

168 Exhibition Street, Melbourne, 3000
7 May 1980

Creditors, next of kin, and others having claims against the estate of any of the under-mentioned deceased persons are required to send particulars of their claims to the Public Trustee, 168 Exhibition Street, Melbourne, Vic. 3000, the personal representative, on or before 21 July 1980, after which date the Public Trustee may convey or distribute the assets having regard only to the claims of which the Public Trustee then has notice:

CALDWELL, CLEMENT LEWES JOHN, late of Ballarat, pensioner, died 26 October 1979.

CARR, WILLIAM, late of Mont Park, pensioner, died 12 December 1979.

COLE, MICHAEL WILLIAM, late of 11 Lindisfarne Avenue, Croydon, meter reader, died 23 February 1980.

COOPER, GILBERTA ELIZABETH, formerly of 32 Madura Street, Ascot Vale, but late of Mont Park, widow, died 27 February 1980.

COUSINS, HILDA GRACE, late of 4 Grundy Street, Pascoe Vale South, widow, died 12 March 1980.

CUNNINGHAM, JOHN MILLAR, formerly of Unit 6, 17 Oswald Street, Elsternwick, but late of Masonic Homes, 313 Punt Road, Windsor, retired electrical contractor, died 8 February 1980.

ELSHAUG, HENRY BERTRAM, late of Unit 6/397 Warrigal Road, Burwood, retired public servant, died 5 October 1979.

HENRY, GLADYS JOSEPHINE, late of 309 Esplanade East, Port Melbourne, widow, died 18 February 1974.

HILLIER, IVAN VINCENT, also known as Hillier, Ivan Charles, late of 612 Victoria Street, North Melbourne, labourer, died 28 February 1980.

HONAN, GEORGE JOSEPH, also known as George Honan, late of Lindhe Lane, Lang Lang, retired foreman, died 22 December 1979.

JONES, HERBERT CLAUDE, late of 45 Pridham Street, Maidstone, retired moulder, died 29 January 1980.

KEATS, PETER JAMES, also known as Keats, Peter John, late of 83 Alexander Avenue, Upwey, retired, died 8 February 1980.

LONG, MARION GWENDOLINE, formerly of 14/131 Riversdale Road, Hawthorn, but late of 151 Adam Clarke Village Golf Links Road, Baxter, widow, died 8 February 1980.

MCNAMARA, RUBY CONSTANCE, formerly of 36 Fenwick Street, Thornbury, but late of Glen Roy Private Hospital, 87 Chapman Avenue, Glenroy, spinster, died 3 March 1980.

MCNAMARA, RUBY EDNA, late of 8 Kingsford Avenue, Merlynston, married woman, died 17 February 1980.

MARSHALL, WILLIAM GEORGE, late of 4 Lochiel Avenue, Edithvale, retired truck driver, died 30 December 1979.

PRIOR, EDWIN MURRAY, late of 17 Dalgety Street (in the will called Dalgetty Street), West Brunswick, retired clerk, died 1 March 1980.

ROGERS, BRIAN LESLIE SHANE, late of Flat 36, 11 Marine Parade, St. Kilda, railway engineman, died 18 March 1980.

STEWART, DAVID JOHN, late of Walcha, N.S.W., retired gas engineer, died 21 May 1979.

Melbourne, 7 May 1980

P. T. SPENCER
Public Trustee

APPOINTMENTS AND RESIGNATIONS

APPOINTMENTS

His Excellency the Governor of the State of Victoria, by and with the advice of the Executive Council thereof, has, by Orders made on 6 May 1980, been pleased to make the under-mentioned appointments, viz.:—

HEALTH COMMISSION

Superintendent

ALEXANDER FRANK JOHN BELL, M.B., B.S., D.P.M., M.R.C.Psych., M.A.N.Z.C.P., to be Superintendent, Warrnambool Psychiatric Hospital, Mental Hospital, Training Centre and Lewana Clinic, pursuant to the provisions of section 26 (1) of the *Mental Health Act 1959* for the period 28 April 1980 to 2 May 1980, vice Dr D. Kocher, on leave.

Deputy Superintendent

PAUL CHRISTOPHER HOLMAN, M.B., B.Ch., M.R.C.S., L.R.C.P., M.A., M.R.C.Psych., to be Deputy Superintendent, Traralgon Psychiatric and Mental Hospital, pursuant to the provisions of section 26 (1) of the *Mental Health Act 1959* as from 21 April 1980, vice Dr V. R. Vasudevan, transferred.

Trustees of Public Cemeteries

WALLACE SCOTT to be an additional Trustee of the Maddingley General Cemetery,

JOHN MELVILLE PARKER to be a Trustee of the Quambatook Public Cemetery, vice G. W. Hosking, resigned,

GRAEME JAMES MANN to be a Trustee of the Quambatook Public Cemetery, vice D. C. Baker, resigned,

HAROLD MAXWELL PEEL to be an additional Trustee of the Bellarine Public Cemetery,

ALLAN BATH to be an additional Trustee of the Buninyong Public Cemetery pursuant to section 3 (1) of the *Cemeteries Act 1958*.

Member of Committee of Management of Hospital

DAVID ALOYSIOUS PATRICK MCKENZIE-MCHARG to be Government appointee on the Committee of Management, Ovens and Murray Hospital for the Aged, for a further period of three years commencing 5 May 1980 pursuant to the provisions of section 48 (1) (a) (ii) of the *Hospitals and Charities Act 1958*.

LAW DEPARTMENT

Justices of the Peace

WILLIAM RUSSELL ANDREW, 65 Victoria Street, Sandringham,

ESTELLE PEGGY BATSON, 49 Grimes Road, Point Lonsdale, NANCY LOUISE BUTLER, 138 The Boulevard, Essendon,

KOPELE GELMAN, 97 Rose Street, Fitzroy, JOHN EDWARD HARMER, 76 Henty Street, Casterton,

VALDA IRENE LARGE, 4 Pindari Street, Glen Waverley, LEONARD ROGER NAPHTHINE, Armytage Road, Winchelsea,

YVONNE RUTH SHADY, Geelong Road, Skipton, and NOEL HOWARD WEBSTER, 1 Paranda Court, Vermont,

to be Justices of the Peace for the State of Victoria.

Commissioners for Taking Declarations, &c.

ANDREW D'ARCY EDGELL BUSH, 98 Drummond Street, Carlton South,

GUIDO CIACIA, 438 Bell Street, Pascoe Vale South, CHARLES CALDER EDNEY, 570 Bourke Street, Melbourne,

PATRICIA JEAN HAIR, 450 Little Collins Street, Melbourne, DENISE MARGARET HATTAM, 21 Henty Street, East Brighton,

LESLIE NEIL HORSFIELD, Thorpdale,

WENDY ANNE KNOWLES, 356 Collins Street, Melbourne, ANDREW KOLEVAS, 67 Meyrick Crescent, Viewbank, NORMAN ERIC LAMB, 32 Smith Street, Stawell, JOHN ARTHUR PENMAN, 555 Collins Street, Melbourne, VALMONT JOHN POLLARD, Glenormiston South, ALAN JOHN ROSS, Grassmere, GLENISE MAVIS WATKINSON, Dandenong, MICHAEL JOHN WHITEOAK, 12 Mawson Court, Vermont, ALLEN GEORGE WILLIAMS, 6 Beech Court, Campbellfield, and

ALAN REGINALD WORTS, 1 Church Street, Colac, to be Commissioners for taking Declarations and Affidavits under the *Evidence Act 1958*.

Registrar of the County Court

ROSS WILLIAM COOK, Clerk of Courts, Class "CC-2", to be Registrar of the County Court at Kerang, vice P. Grant on recreation leave.

PUBLIC WORKS DEPARTMENT

Re-appointment of Inspector (Prosecutions)

EDWIN GEORGE STAFFORD, to be appointed as Inspector (Prosecutions) for a period of six (6) months as from 20 May 1980 pursuant to section 95 of the *Marine Act 1958*.

TOM FORRISTAL

Clerk of the Executive Council

At the Executive Council Chamber
Melbourne, 6 May 1980

Stock Medicines Act 1958

APPOINTMENT OF MEMBERS TO THE STOCK MEDICINES BOARD

In pursuance of the powers conferred upon me by subsection (2) of section 4 of the *Stock Medicines Act 1958*, I, Ian Winton Smith, Minister of Agriculture for the time being of the State of Victoria, hereby appoint FRANCIS AHERN, an officer of the Health Commission of Victoria to be a member of the Stock Medicines Board constituted under the provisions of the said Act for the period ending 20 February 1981.

Dated 1 May 1980

IAN SMITH

Minister of Agriculture

Liquor Control Act 1968

APPOINTMENT OF LICENSING INSPECTORS

Whereas on 6 February 1980, Sinclair Imrie Miller, the Chief Commissioner of Police for the State of Victoria acting pursuant to the power vested in him by Section 6A of the *Police Regulation Act 1958* delegated to me the undersigned David John Swanson being an Assistant Commissioner of Police for the said State and the person referred to in the said delegation all powers and functions vested in him by the *Liquor Control Act 1968*, from 6 February 1980, now therefore I do hereby appoint the following Officers of Police as Licensing Inspectors for the Divisions of the Police Districts as shown :

<i>Division Number</i>	<i>Police District</i>	<i>Rank and Name</i>
3	Heidelberg	Inspector John Beveridge Barclay (from 29.4.80 to 21.5.80)
2	Malvern	Inspector Alan James Rundell (from 6.4.80 to 12.5.80)
3	Malvern	Inspector Raymond Ernest Ridley (from 1.4.80 to 12.5.80)
1	Maroondah	Inspector Kevin Neville Hastings (from 11.5.80 to 7.6.80)
4	Maroondah	Inspector Alan Kingsley Frowd (from 1.6.80 to 28.6.80)
4	Prahran	Inspector Graeme Francis Crawford (from 5.5.80 to 24.5.80)

D. J. SWANSON

8.5.1980 Assistant Commissioner (Services)

Companies Act 1961

APPOINTMENT OF OFFICIAL LIQUIDATOR

I, Haddon Storey, Her Majesty's Attorney-General for the State of Victoria, pursuant to section 231 of the Companies Act 1961, hereby appoint DOUGLAS EWART TONKIN of 51 Queen Street, Melbourne, Accountant (being a registered liquidator within the meaning of the said section 231), to be an Official Liquidator.

Dated at Melbourne, 5 May 1980

HADDON STOREY
Attorney-General

REVOCATION OF APPOINTMENT

LAW DEPARTMENT

His Excellency the Governor of the State of Victoria by and with the advice of the Executive Council thereof, has, by Order made on 6 May 1980, revoked the appointment of GEORGE WILLIAM JOHN JENKINS as a Commissioner for taking declarations and affidavits under the Evidence Act 1958.

TOM FORRISTAL
Clerk of the Executive Council

At the Executive Council Chamber
Melbourne, 6 May 1980

ORDERS IN COUNCIL

WATER ACT 1958

At the Executive Council Chamber, Melbourne, the
twenty-sixth day of February, 1980

PRESENT:

His Excellency the Governor of Victoria

Mr Balfour	Mr Dixon
Mr Jona	Mr Lacy

DECLARATION OF THAT AREA OF LAND COMPRISING THE MUNICIPALITY OF THE CITY OF TRARALGON IN RESPECT OF WHICH THE STATE RIVERS AND WATER SUPPLY COMMISSION HAS DECLARED THAT ARRANGEMENTS FOR CONSULTATION ARE DESIRABLE IN INVESTIGATING, EVALUATING, IMPLEMENTING AND CO-ORDINATING A DRAINAGE, FLOOD MITIGATION AND RIVER MANAGEMENT PROPOSAL

Whereas pursuant to the provisions of section 33A of the Water Act, the State Rivers and Water Supply Commission has declared that arrangements for consultation are desirable in investigating, evaluating, implementing and co-ordinating a drainage, flood mitigation and river management proposal in respect of that area of land comprising the Municipality of the City of Traralgon.

And whereas under the provisions of section 33A of the Water Act the Governor in Council may declare the area of a proposal as aforementioned to be an area to which the provisions of sub-sections (2) to (5), inclusive of the said section 33A shall apply.

Now therefore His Excellency the Governor of the State of Victoria, by and with the advice of the Executive Council of the said State, on the recommendation of the Minister of Water Supply, hereby declares that, as on and from the date of this Order, the area of land comprising the Municipality of the City of Traralgon shall be an area to which the provisions of sub-sections (2) to (5), inclusive, of section 33A of the Water Act shall apply.

REVOCATION OF APPOINTMENT OF OFFICIAL LIQUIDATOR

I, Haddon Storey, Her Majesty's Attorney-General for the State of Victoria, in exercise of my powers under the provisions of section 231 (1) of the Companies Act 1961, do hereby revoke the appointment of LESLIE PHILIP SMART as an Official Liquidator.

Dated at Melbourne, 5 May 1980

HADDON STOREY
Attorney-General

RESIGNATIONS

LAW DEPARTMENT

His Excellency the Governor of the State of Victoria by and with the advice of the Executive Council thereof has by Order made on 6 May 1980 accepted the resignations of:—

FRANCIS WILLIAM EDWARD GIBBINS,
THOMAS CHARLES LEMPRIERE,
BARRY ROBIN MCCLURE, and
TREVOR EDWARD LESLIE MINSTER,
as Commissioners for taking Declarations and Affidavits under the Evidence Act 1958.

TOM FORRISTAL
Clerk of the Executive Council

At the Executive Council Chamber
Melbourne, 6 May 1980

And the Honorable Frederick James Granter, Her Majesty's Minister of Water Supply for the State of Victoria, shall give the necessary directions herein accordingly.

TOM FORRISTAL
Clerk of the Executive Council

CROWN LAND (RESERVES) ACT 1978

At the Executive Council Chamber, Melbourne, the
thirtieth day of April, 1980

PRESENT:

His Excellency the Governor of Victoria	
Mr Houghton	Mr Dixon
Mr Maclellan	Mr Lieberman

"TRARALGON RECREATION RESERVE" VESTED IN THE CITY OF TRARALGON

His Excellency the Governor of the State of Victoria, in the Commonwealth of Australia, by and with the advice of the Executive Council of the said State, pursuant to section 16 (1) of the Crown Land (Reserves) Act 1978, doth hereby direct that the Crown land described in the Schedule hereunder be vested in the municipality of the City of Traralgon on trust for the purposes for which the land has been reserved, and, pursuant to section 16 (2) of the said Act, doth also empower the said municipality to grant leases or licences for a term not exceeding 21 years in respect of the land for the purposes of the reservation.

SCHEDULE

The Crown land in the Township of Traralgon—

1. 4.046 hectares, permanently reserved as a site for Recreation by Order in Council of 11 November 1875 (see *Government Gazette* dated 3 December 1875);

2. 2979 square metres, permanently reserved as a site for Recreation by Order in Council of 23 August 1932 (see *Government Gazette* dated 31 August 1932);

3. 4831 square metres, temporarily reserved as a site for Public Recreation by Order in Council of 19 July 1955 (see *Government Gazette* dated 27 July 1955)—(Rs.2039).

And the Honorable William Vasey Houghton, Her Majesty's Minister of Lands for the State of Victoria, shall give the necessary directions herein accordingly.

TOM FORRISTAL
Clerk of the Executive Council

ROAD TRAFFIC ACT 1958

At the Executive Council Chamber, Melbourne, the sixth day of May, 1980

PRESENT:

His Excellency the Governor of Victoria

Mr Balfour
Mr Lacy

Mr Lieberman

In pursuance of the powers conferred by the Road Traffic Act 1958, His Excellency the Governor of the State of Victoria, in the Commonwealth of Australia, by and with the advice of the Executive Council of the said State, and at the request in writing of the Council of the City of Keilor, doth by this Order extend the provisions of the said Act to the land under the control of the City of Keilor shown by hatching on the plan hereunder.

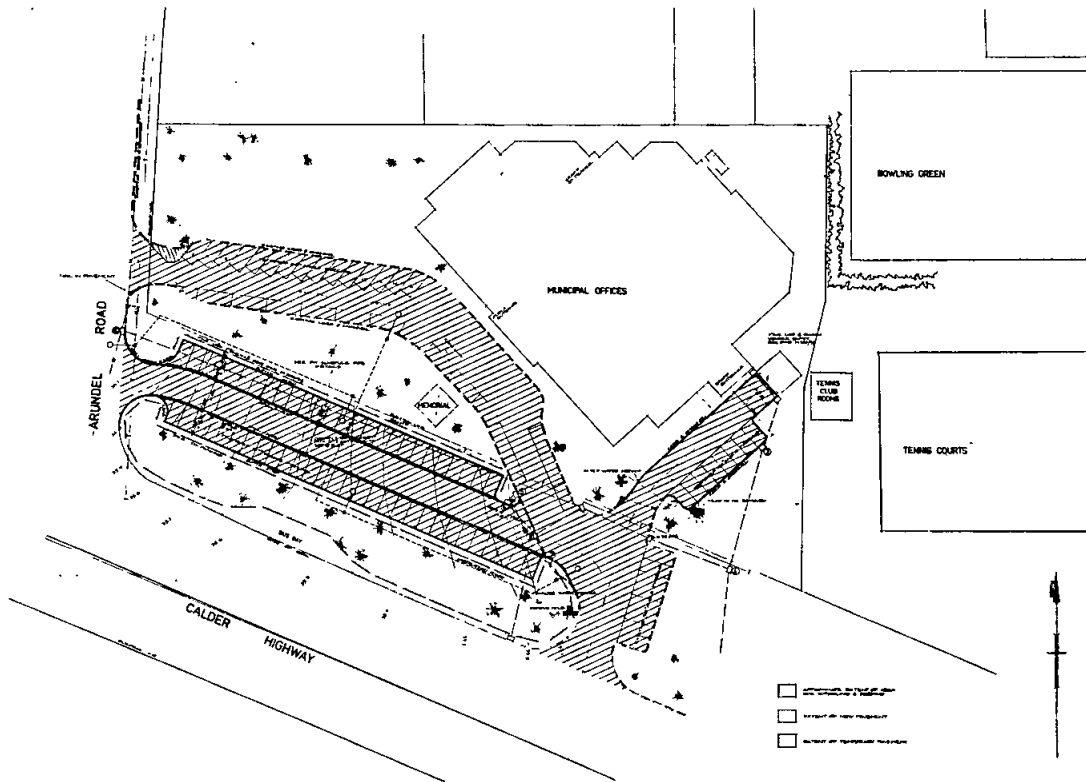

And the Honorable Lindsay Hamilton Simpson Thompson, Her Majesty's Minister for Police and Emergency Services for the State of Victoria, shall give the necessary directions herein accordingly.

TOM FORRISTAL
Clerk of the Executive Council

LOCAL GOVERNMENT ACT 1958

At the Executive Council Chamber, Melbourne, the sixth day of May, 1980

PRESENT:

His Excellency the Governor of Victoria
 Mr Balfour | Mr Lieberman
 Mr Lacy

ROADS DISCONTINUED—CITY OF FOOTSCRAY

Whereas it is provided in section 528 (2) of the Local Government Act 1958, that where a road (whether or not a public highway but not being a road set out on land of the Crown) or any part thereof is not required for public use, the Governor in Council on the request of the council of the municipality in which such road is situated made not less than one month after publishing in a newspaper generally circulating in the district and posting to the registered proprietor (if any) of the land and the owners and occupiers (if any) of lands abutting or immediately adjacent to the road notice of intention to make such a request may by Order published in the Government Gazette direct that such road or part shall be discontinued and thereupon such road or part shall be discontinued accordingly.

And whereas the Council of the City of Footscray has requested that the Governor in Council direct that a road off Paisley Street and a road off Pickett Street, Footscray be discontinued and not less than one month previously has published in a newspaper generally circulating in the district and posted to the registered proprietor of the land in the roads and to the owners and occupiers of lands abutting or immediately adjacent to the roads notice of intention to make such a request.

Now therefore, His Excellency the Governor of the State of Victoria, by and with the advice of the Executive Council thereof, hereby directs that the said roads which are shown by hatching on the plans hereunder, shall be discontinued and the land in the said roads may be retained by the Council of the City of Footscray for municipal purposes.

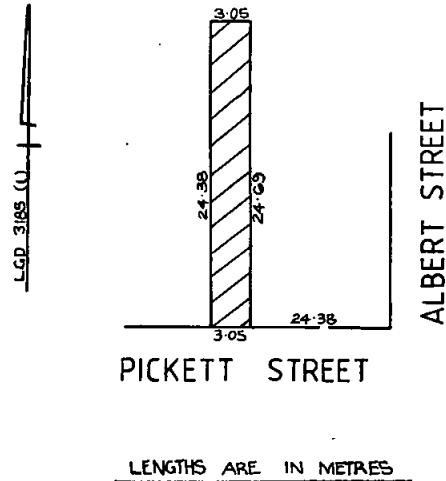
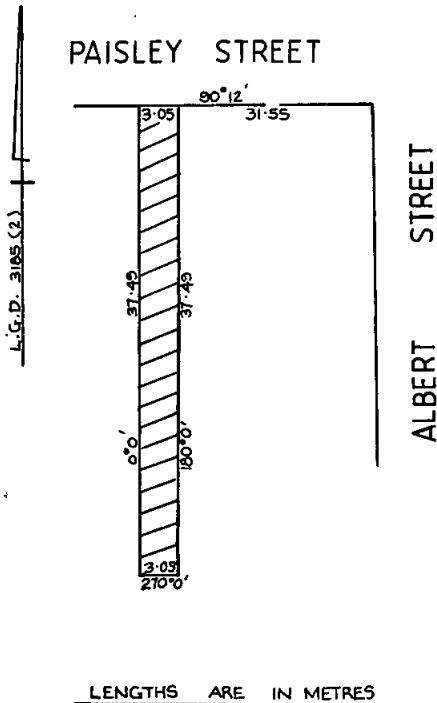

And the Honorable Digby Glen Crozier, Her Majesty's Minister for Local Government in the State of Victoria, shall give the necessary directions herein accordingly.

TOM FORRISTAL
 Clerk of the Executive Council

LOCAL GOVERNMENT ACT 1958

At the Executive Council Chamber, Melbourne the sixth day of May, 1980

PRESENT:

His Excellency the Governor of Victoria
 Mr Balfour | Mr Lieberman
 Mr Lacy

ROADS DISCONTINUED—CITY OF COBURG

Whereas it is provided in section 528 (2) of the Local Government Act 1958, that where a road (whether or not a public highway but not being a road set out on land of the Crown) or any part thereof is not required for public use, the Governor in Council on the request of the council of the municipality in which such road is situated made not less than one month after publishing in a newspaper generally circulating in the district and posting to the registered proprietor (if any) of the land and the owners and occupiers (if any) of the lands abutting or immediately adjacent to the road notice of intention to make such a request may by Order published in the Government Gazette direct that such road or part shall be discontinued and thereupon such road or part shall be discontinued accordingly.

And whereas the Council of the City of Coburg has requested that the Governor in Council direct that roads between Kinross and Irvine Streets, Coburg be discontinued and not less than one month previously has published in a newspaper generally circulating in the district and posted to the registered proprietor of the land in the roads and to the owners and occupiers of lands abutting or immediately adjacent to the roads notice of intention to make such request.

Now therefore, His Excellency the Governor of the State of Victoria, by and with the advice of the Executive Council thereof, hereby directs:

- (a) that the said roads which are shown by hatching on the plan hereunder shall be discontinued;

- (b) that notwithstanding such discontinuance the Melbourne and Metropolitan Board of Works shall continue to have and possess the same right title power authority or interest in or in relation to the whole of the land shown by hatching on the said plan as it had or possessed prior to such discontinuance with respect to or in connection with any drains or pipes laid or erected in on or over such land for the purposes of drainage or sewerage;
- (c) that, subject to any such right title power authority or interest the land in the said roads may be sold by the Council of the City of Coburg by agreement.

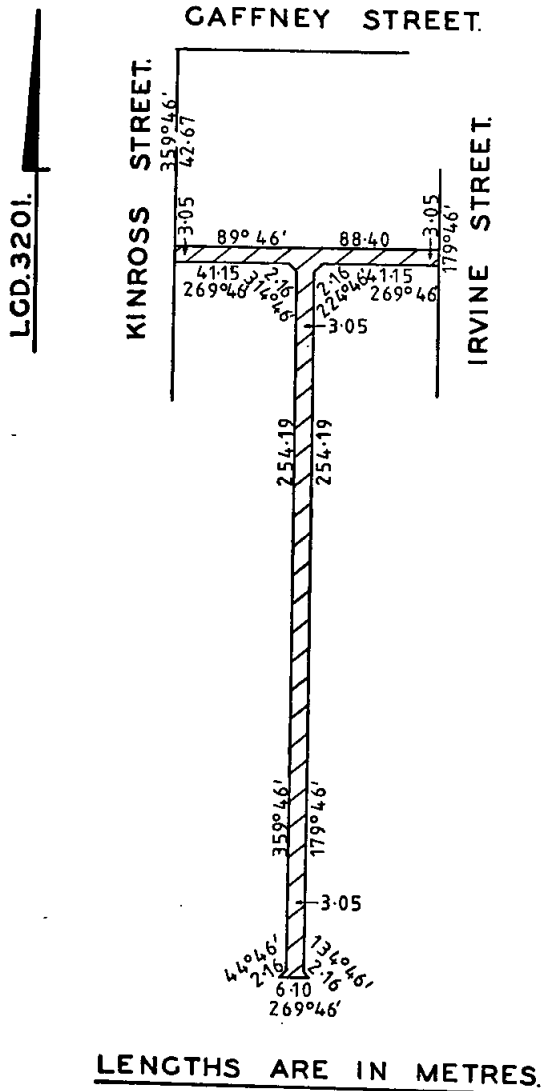

And the Honorable Digby Glen Crozier, Her Majesty's Minister for Local Government for the State of Victoria, shall give the necessary directions herein accordingly.

TOM FORRISTAL
Clerk of the Executive Council

LOCAL GOVERNMENT ACT 1958

At the Executive Council Chamber, Melbourne, the sixth day of May, 1980

PRESENT:

His Excellency the Governor of Victoria
Mr Balfour | Mr Lieberman
Mr Lacy

APPLICATION TO ELECTIONS OF COUNCILLORS FOR THE SHIRE OF MANSFIELD OF REGULATIONS RELATING TO COMPULSORY VOTING

Whereas it is provided in section 149 of the Local Government Act 1958, that the Governor in Council on the petition of the council of any municipality, may by Order published in the Government Gazette apply to elections of councillors for such municipality with any modifications provided for in such Order, all or any of the Regulations relating to compulsory voting made under the said section 149.

Now therefore, His Excellency the Governor of the State of Victoria, by and with the advice of the Executive Council thereof, and in pursuance of a petition of the Council of the Shire of Mansfield doth hereby Order that the Regulations relating to the compulsory voting at municipal elections made pursuant to the provisions of the said section 149 shall apply to elections of councillors for the said municipality.

And the Honorable Digby Glen Crozier, Her Majesty's Minister for Local Government for the State of Victoria, shall give the necessary directions herein accordingly.

TOM FORRISTAL
Clerk of the Executive Council

LOCAL GOVERNMENT ACT 1958

At the Executive Council Chamber, Melbourne the sixth day of May, 1980

PRESENT:

His Excellency the Governor of Victoria
Mr Balfour | Mr Lieberman
Mr Lacy

ROAD DISCONTINUED—CITY OF FOOTSCRAY

Whereas it is provided in section 528 (2) of the Local Government Act 1958, that where a road (whether or not a public highway but not being a road set out on land of the Crown) or any part thereof is not required for public use, the Governor in Council on the request of the council of the municipality in which such road is situated made not less than one month after publishing in a newspaper generally circulating in the district and posting to the registered proprietor (if any) of the land and the owners and occupiers (if any) of lands abutting or immediately adjacent to the road notice of intention to make such a request may by Order published in the Government Gazette direct that such road or part shall be discontinued and thereupon such road or part shall be discontinued accordingly.

And whereas the Council of the City of Footscray has requested that the Governor in Council direct that a road at the rear of Nos. 10-12 Sydenham Street, Footscray be discontinued and not less than one month previously has published in a newspaper generally circulating in the district and posted to the registered proprietor of the land in the road and to the owners and occupiers of lands abutting or immediately adjacent to the road notice of intention to make such a request.

Now therefore, His Excellency the Governor of the State of Victoria, by and with the advice of the Executive Council thereof, hereby directs:—

- (a) that the said road which is shown by hatching on the plan hereunder, shall be discontinued;

LOCAL GOVERNMENT ACT 1958

At the Executive Council Chamber, Melbourne, the sixth day of May, 1980

PRESENT:

His Excellency the Governor of Victoria
 Mr Balfour | Mr Lieberman
 Mr Lacy

CONFIRMATION OF SEPARATE RATE—CITY OF HEIDELBERG

In pursuance of the provisions of section 287 of the Local Government Act 1958, His Excellency the Governor of the State of Victoria, by and with the advice of the Executive Council thereof hereby confirms a separate rate of 1.5321 cents in the dollar on the site value of the properties described in the Schedule hereunder, which rate was made by the City of Heidelberg on 18 February 1980 for the purpose of the preparation and implementation of an urban renewal proposal pursuant to the provisions of the Urban Renewal Act 1970 for the Mall Shopping Centre, West Heidelberg.

SCHEDULE

The Mall, West Heidelberg—

Properties known as and numbered 15-23, 25, 27, 29, 39, 41, 43, 45, 4/47-49, 3/47-49, 2/47-49, 1/47-49, 4/51-53, 3/51-53, 2/51-53, 1/51-53, 55, 57, rear 57, 59, 61, 63, 65, 67, 69, 71, 73, 75, 1/70, 2/70, A1/70, 68, 66, 64, 62, 60, 58, 56, rear 52-58, 54, 52, 50, 48, 40-44, 38, 36, 34, 28-32, 26, 22-24, 18, 16, 1 and 2/16, 14, 12, 8-10, 6, 4 and 2.

Bell Street, West Heidelberg—

Properties known as and numbered 304, 302, 300 and 296-298.

And the Honorable Digby Glen Crozier, Her Majesty's Minister for Local Government for the State of Victoria, shall give the necessary directions herein accordingly.

TOM FORRISTAL
 Clerk of the Executive Council

LOCAL GOVERNMENT ACT 1958

At the Executive Council Chamber, Melbourne, the sixth day of May, 1980

PRESENT:

His Excellency the Governor of Victoria
 Mr Balfour | Mr Lieberman
 Mr Lacy

ALTERATION OF TIME FOR CLOSING POLL AT MUNICIPAL ELECTIONS—SHIRE OF MANSFIELD

His Excellency the Governor of the State of Victoria by and with the advice of the Executive Council thereof, in pursuance of the powers conferred by section 134 of the Local Government Act 1958, and in compliance with the prayer of a petition presented by the Council of the Shire of Mansfield declares that the hour for closing the poll at municipal elections for the said Shire shall be six o'clock in the afternoon.

And the Honorable Digby Glen Crozier, Her Majesty's Minister for Local Government for the State of Victoria, shall give the necessary directions herein accordingly.

TOM FORRISTAL
 Clerk of the Executive Council

CROWN LAND (RESERVES) ACT 1978

At the Executive Council Chamber, Melbourne, the sixth day of May, 1980

PRESENT:

His Excellency the Governor of Victoria
 Mr Balfour | Mr Lieberman
 Mr Lacy

CROWN LANDS PERMANENTLY RESERVED

His Excellency the Governor of the State of Victoria, in the Commonwealth of Australia, by and with the advice of the Executive Council of the said State, pursuant to the provisions of sections 4 and 7 of the Crown Land (Reserves) Act 1978, and being of the opinion that the Crown lands concerned are required for the purposes respectively mentioned, doth hereby permanently reserve and also except from occupation for mining purposes under any miner's right, the Crown lands hereinafter described, viz.:

FRANKLIN—For Conservation of an Area of Natural Interest—3169 square metres, being Crown allotment 31A, section 6, Parish of Franklin, as indicated by hatching on plan hereunder—(F.77^(*)) (Rs.10883).

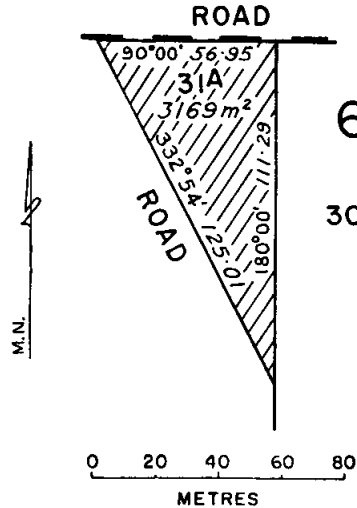

HOLCOMBE—For Conservation of an Area of Natural Interest—4.9 hectares, more or less, being Crown allotment 18H, Parish of Holcombe, as indicated by hatching on plan hereunder—(H.97^(*)) (Rs.10877).

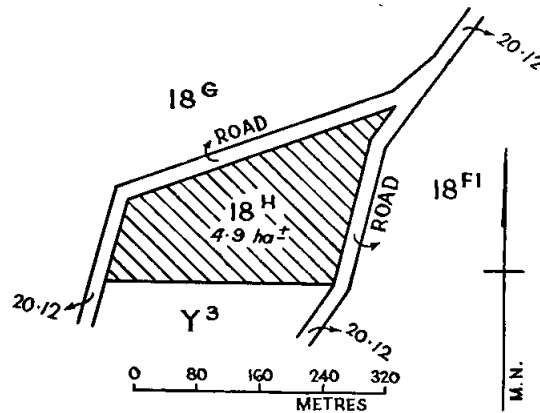

HOLCOMBE—For Conservation of an Area of Natural Interest—4 hectares, more or less, being Crown allotment A48, Parish of Holcombe, as indicated by hatching on plan hereunder—(H.97(*) (Rs.10878).

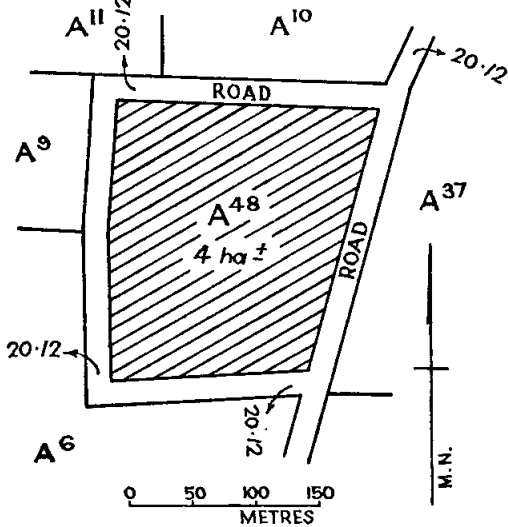

HOLCOMBE—For Conservation of an Area of Natural Interest—6.243 hectares, being Crown allotment 8c, Parish of Holcombe, as indicated by hatching on plan hereunder—(H.97(*) (Rs.10880).

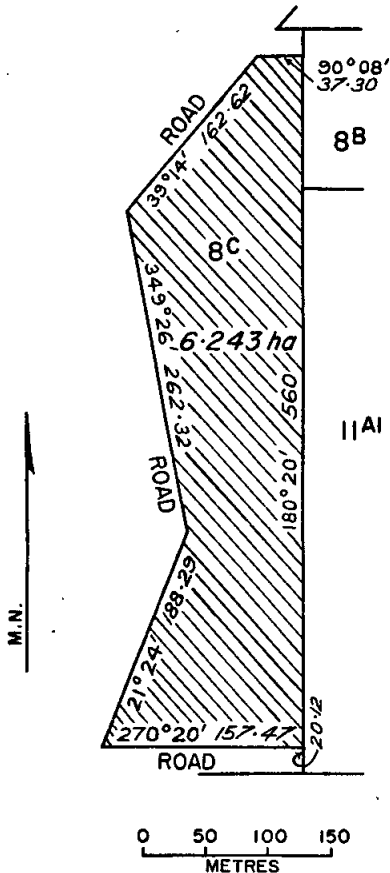

WOODEND—For Conservation of an Area of Natural Interest—4.323 hectares, being Crown allotment 2c, section D, Parish of Woodend, as indicated by hatching on plan hereunder—(W.200(K⁶) (Rs.10718).

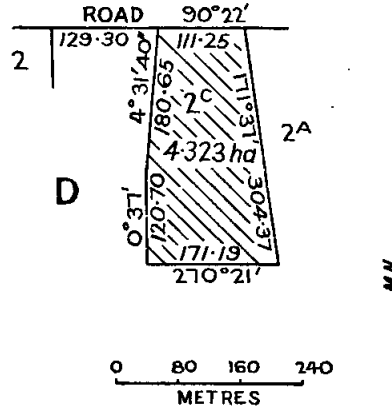

And the Honorable William Vasey Houghton, Her Majesty's Minister of Lands for the State of Victoria, shall give the necessary directions herein accordingly.

TOM FORRISTAL
Clerk of the Executive Council

CROWN LAND (RESERVES) ACT 1978

At the Executive Council Chamber, Melbourne, the sixth day of May, 1980

PRESENT:

His Excellency the Governor of Victoria
Mr Balfour | Mr Lieberman
Mr Lacy

REVOCATION OF TEMPORARY RESERVATIONS OF LANDS BY ORDERS IN COUNCIL

His Excellency the Governor of the State of Victoria, in the Commonwealth of Australia, by and with the advice of the Executive Council of the said State, pursuant to the provisions of section 10 of the *Crown Land (Reserves) Act 1978*, doth hereby revoke the temporary reservations of lands by Orders in Council hereinafter described, viz.:

MYSTIC PARK—The temporary reservation by Order in Council of 22 July 1902 of 4047 square metres of land in the Township of Mystic Park (in section 1) as a site for a State School—(Rs.7118).

MYSTIC PARK—The temporary reservation by Order in Council of 7 November 1906 of 8094 square metres of land in the Township of Mystic Park (in section 1) as a site for a State School—(Rs.7118).

SHELFORD—The temporary reservation by Order in Council of 17 December 1860 of 8094 square metres of land in the Township of Shelford (at Shelford, on the River Leigh in Order) (in section 11) as a site for a Pound—(Rs.10531).

OAKLEIGH—The temporary reservation by Order in Council of 15 March 1978 of 1.472 hectares of land being Crown allotment 43A, Township of Oakleigh as a site for State School purposes, so far only as regards the portion thereof containing 71 square metres, as defined by description and hatching on plan published in the *Government Gazette* of 16 April 1980, is concerned—(O.1^a) (Rs.6822).

And the Honorable William Vasey Houghton, Her Majesty's Minister of Lands for the State of Victoria, shall give the necessary directions herein accordingly.

TOM FORRISTAL
Clerk of the Executive Council

CROWN LAND (RESERVES) ACT 1978

At the Executive Council Chamber, Melbourne, the sixth day of May, 1980

PRESENT:

His Excellency the Governor of Victoria
 Mr Balfour | Mr Lieberman
 Mr Lacy |

CROWN LAND TEMPORARILY RESERVED

His Excellency the Governor of the State of Victoria, in the Commonwealth of Australia, by and with the advice of the Executive Council of the said State, pursuant to the provisions of sections 4 and 7 of the Crown Land (Reserves) Act 1978, and being of the opinion that the Crown land concerned is required for the public purpose mentioned, doth hereby temporarily reserve and also except from occupation for mining purposes under any miner's right, the Crown land hereinafter described, viz.:

KIATA—For National Parks Service purposes, 950 square metres, more or less, being Crown allotment 7A, section 19, Township of Kiata, as indicated by hatching on plan hereunder—(K.13(7)) (Rs.11154).

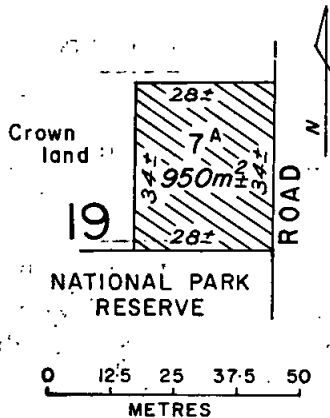

And the Honorable William Vasey Houghton, Her Majesty's Minister of Lands for the State of Victoria, shall give the necessary directions herein accordingly.

TOM FORRISTAL
 Clerk of the Executive Council

CROWN LAND (RESERVES) ACT 1978

At the Executive Council Chamber, Melbourne, the sixth day of May, 1980

PRESENT:

His Excellency the Governor of Victoria
 Mr Balfour | Mr Lieberman
 Mr Lacy |

CROWN LANDS TEMPORARILY RESERVED

His Excellency the Governor of the State of Victoria, in the Commonwealth of Australia, by and with the advice of the Executive Council of the said State, pursuant to the provisions of sections 4 and 7 of the Crown Land (Reserves) Act 1978, and being of the opinion that the Crown Lands concerned are required for the purposes respectively men-

tioned, doth hereby temporarily reserve and also except from occupation for mining purposes under any miner's right, the Crown lands hereinafter described, viz.:

BROADFORD—For area and facilities for the study of the natural environment, 55.71 hectares, being Crown allotment 71, Parish of Broadford, as indicated by hatching on plan hereunder—(Parish 2235) (Rs.4564).

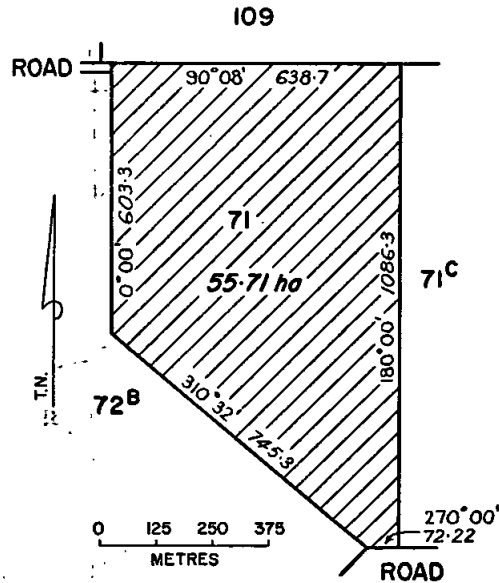

CARWARP WEST—For Conservation of an Area of Natural Interest, 39.77 hectares, being Crown allotment 43, Parish of Carwarp West, as indicated by hatching on plan hereunder—(C.473(3)) (Rs.11123).

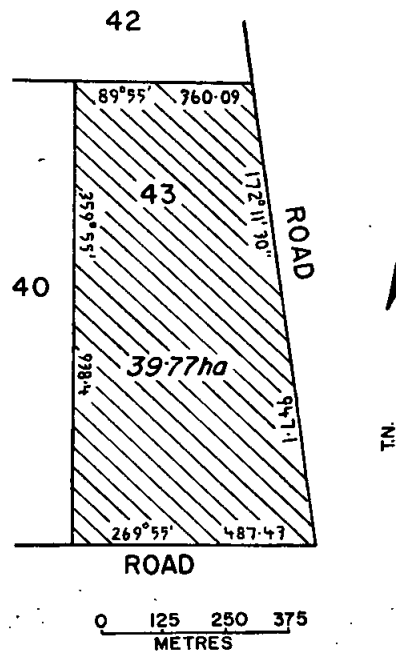

GHIN GHIN—For Management of Wildlife, 42.5 hectares, more or less, being Crown allotment 9, Parish of Ghin Ghin, as indicated by hatching on plan hereunder—(Parish 2651) (Rs.10836).

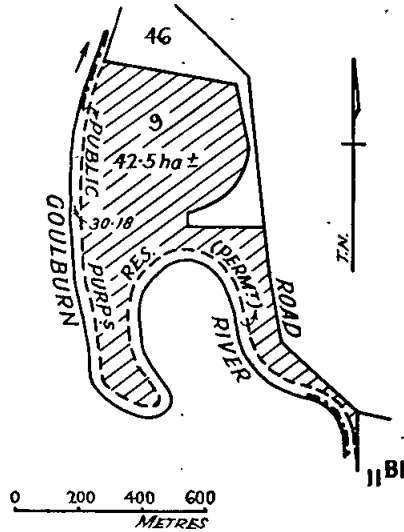

GNARR—For Conservation of an Area of Natural Interest, 122 hectares, more or less, being Crown allotment 7, Parish of Gnarr, as indicated by hatching on plan hereunder—(G.243⁽³⁾) (Rs.11140).

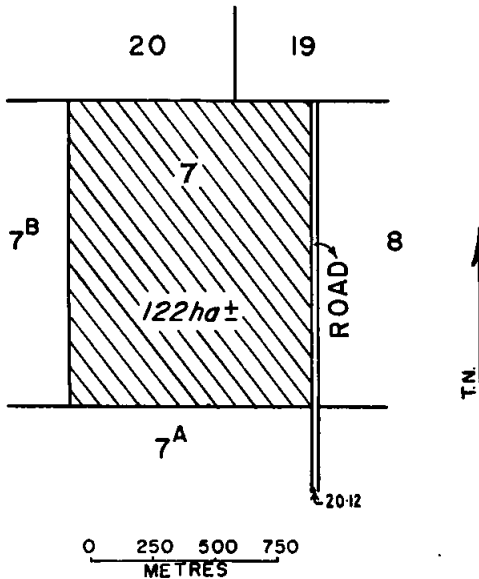

QUEENSTOWN—For Conservation of an Area of Natural Interest, 4.705 hectares, being Crown allotment 5, section F, Parish of Queenstown, as indicated by hatching on plan hereunder—(Q.22(?)) (Rs.11114).

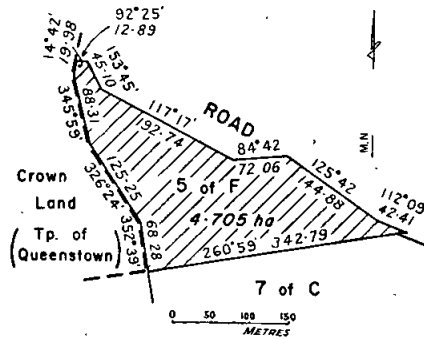

And the Honorable William Vasey Houghton, Her Majesty's Minister of Lands for the State of Victoria, shall give the necessary directions herein accordingly.

TOM FORRISTAL
Clerk of the Executive Council

LAND ACT 1958

At the Executive Council Chamber, Melbourne, the sixth day of May, 1980

PRESENT:

His Excellency the Governor of Victoria
Mr Balfour | Mr Lieberman
Mr Lacy

UNUSED ROAD CLOSED

His Excellency the Governor of the State of Victoria, in the Commonwealth of Australia, by and with the advice of the Executive Council of the said State, pursuant to the provisions of section 349 of the Land Act 1958 and with the concurrence in writing of the council of the municipality concerned and that of any adjoining land owners, doth hereby close the unused road hereinafter described, viz.:

Municipal District of the Shire of Upper Yarra—Parish of Woori Yallock, being the road indicated by hatching on plan hereunder—(W.351(?)) (G.62833).

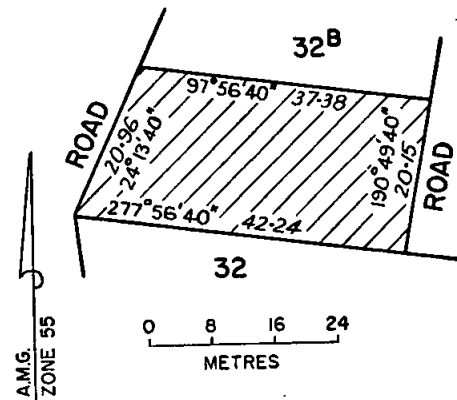

And the Honorable William Vasey Houghton, Her Majesty's Minister of Lands for the State of Victoria, shall give the necessary directions herein accordingly.

TOM FORRISTAL
Clerk of the Executive Council

SUPERANNUATION ACT 1958

At the Executive Council Chamber, Melbourne the sixth day of May, 1980

PRESENT:

His Excellency the Governor of Victoria
Mr Balfour | Mr Lieberman
Mr Lacy

Pursuant to the powers conferred by the provisions of paragraph (ja) of sub-section (1) of section 3 of the Superannuation Act 1958, His Excellency the Governor of the State of Victoria, by and with the advice of the Executive Council thereof doth by this Order declare that the provisions of the Superannuation Act shall apply to the officers named in the schedule set out hereunder.

SCHEDULE

DAVIS, PETER NORMAN, Caulfield Institute of Technology, from and inclusive of 21 May 1980.
TODD, GARY STEPHEN, Caulfield Institute of Technology.
HUNT, KATHRYN, MCGREGOR, ELLEN, REISNER, VLJA and VINES, MARILYN CAROL, Motor Accidents Board.
KATZ, ELLIOTT, Prahran College of Advanced Education, from and inclusive of 10 June 1980.

And the Honorable Lindsay Hamilton Simpson Thompson, Her Majesty's Treasurer for the State of Victoria, shall give the necessary directions herein accordingly.

TOM FORRISTAL
Clerk of the Executive Council

HISTORIC BUILDINGS ACT 1974 (No. 8569)

At the Executive Council Chamber, Melbourne, the sixth day of May, 1980

PRESENT:

His Excellency the Governor of Victoria
Mr Balfour | Mr Lieberman
Mr Lacy

AMENDMENT OF REGISTER OF HISTORIC BUILDINGS

Whereas it is provided by section 3 of the Historic Buildings Act 1974 that the Governor in Council, on the recommendation of the Minister, may by notice of Historic Buildings established under the said Act—

- (a) by adding any specified building;
- (b) by removing any specified buildings; or
- (c) by altering any item.

And whereas the Minister has recommended that the Register be amended.

Now therefore, His Excellency the Governor of the State of Victoria, by and with advice of the Executive Council thereof, doth hereby amend the Register of Historic Buildings in the manner and to the extent shown as follows: by amending "Historic Building No. 33 A.N.Z. Bank, 394-398 Collins Street, Melbourne to Historic Building No. 33, Building, 394-398 Collins Street, Melbourne (to the extent of the total exterior fabric of the building and the interior to the extent of the brick vaulted section of the basement (including the access corridor to those vaults), the total ground and mezzanine floors, the former first floor boardroom, the southern stairwell on all floors (excluding those walls of the liftwells which do not form part of the southern stairwell and the lift doors on floors 1 to 6)."

And the Honorable Louis Stuart Lieberman, Her Majesty's Minister for Planning for the State of Victoria, shall give the necessary directions herein accordingly.

TOM FORRISTAL
Clerk of the Executive Council

STATE ELECTRICITY COMMISSION ACT 1958

At the Executive Council Chamber, Melbourne, the sixth day of May, 1980

PRESENT:

His Excellency the Governor of Victoria
Mr Balfour | Mr Lieberman
Mr Lacy

ELECTRICAL APPROVALS REGULATIONS—
PROCEEDINGS OF ELECTRICAL APPROVALS BOARD
(AMENDMENT) 1980

Pursuant to the powers conferred by the State Electricity Commission Act 1958 and all other powers thereunto enabling His Excellency the Governor of the State of Victoria, acting by and with the advice of the Executive Council thereof, doth hereby, on the recommendation of the State Electricity Commission of Victoria, make the following Regulations, that is to say:

1. (1) These Regulations may be cited as the Electrical Approvals Regulations—Proceedings of Electrical Approvals Board (Amendment) 1980 and shall come into operation on 1 June 1980.

(2) In these Regulations the Electrical Approvals Regulations—Proceedings of Electrical Approvals Board 1934 are called the Principal Regulations.

2. In paragraph (a) of Regulation 9 of the Principal Regulations for the words "One thousand six hundred and ninety dollars" there shall be substituted the expression "One thousand eight hundred and sixty dollars".

And the Honorable James Charles Murray Balfour, Her Majesty's Minister for Minerals and Energy, for the State of Victoria, shall give the necessary directions herein accordingly.

TOM FORRISTAL
Clerk of the Executive Council

WATER ACT 1958

At the Executive Council Chamber, Melbourne, the sixth day of May, 1980

PRESENT:

His Excellency the Governor of Victoria
Mr Balfour | Mr Lieberman
Mr Lacy

GOULBURN-MURRAY IRRIGATION DISTRICT—
DISTRICT EXTENDED CALIVIL IRRIGATION AREA—
BOUNDARIES VARIED

Under the powers conferred by the Water Act 1958 and all other powers enabling him in that behalf, His Excellency the Governor of the State of Victoria, with the advice of the Executive Council of the said State, on the recommendation of the State Rivers and Water Supply Commission, doth hereby declare, order and direct that the Goulburn-Murray Irrigation District be extended and the boundaries of the Calivil Irrigation Area be varied by adding to the said District and Area the land shown by blue colour on a plan approved by the Governor in Council and deposited in the office of the State Rivers and Water Supply Commission at 590 Orrong Road, Armadale (Corr. No. 71/1031) and as on and from 1 June 1980 such District shall be deemed to be so extended and the boundaries of such Area shall be so varied.

And the Honorable Frederick James Granter, Her Majesty's Minister of Water Supply for the State of Victoria, shall give the necessary directions herein accordingly.

TOM FORRISTAL
Clerk of the Executive Council

WATER ACT 1958

At the Executive Council Chamber, Melbourne, the
sixth day of May, 1980

PRESENT:

His Excellency the Governor of Victoria
Mr Balfour | Mr Lieberman
Mr Lacy

GOULBURN—MURRAY IRRIGATION DISTRICT—
DISTRICT EXTENDED KERANG IRRIGATION AREA—
BOUNDARIES VARIED

Under the powers conferred by the Water Act 1958 and all other powers enabling him in that behalf, His Excellency the Governor of the State of Victoria, with the advice of the Executive Council of the said State, on the recommendation of the State Rivers and Water Supply Commission, doth hereby declare, order and direct that the Goulburn—Murray Irrigation District be extended and the boundaries of the Kerang Irrigation Area be varied by adding to the said District and Area the lands shown by blue colour on a plan approved by the Governor in Council and deposited in the office of the State Rivers and Water Supply Commission at 590 Orrong Road, Armadale (Corr. Nos. 64/946, 69/2532, 69/2547) and as on and from 1 June 1980, such District shall be deemed to be so extended and the boundaries of such area shall be so varied.

And the Honorable Frederick James Granter, Her Majesty's Minister of Water Supply for the State of Victoria, shall give the necessary directions herein accordingly.

TOM FORRISTAL
Clerk of the Executive Council

SKIPTON WATERWORKS TRUST

At the Executive Council Chamber, Melbourne, the
sixth day of May, 1980

PRESENT:

His Excellency the Governor of Victoria
Mr Balfour | Mr Lieberman
Mr Lacy

EXTENT OF WATERWORKS AND URBAN DISTRICTS
INCREASED

Under the powers conferred by the Water Act and all other powers enabling him in that behalf, His Excellency the Governor of the State of Victoria, by and with the advice of the Executive Council of the said State, doth hereby declare, order and direct that the extent of the Waterworks and Urban Districts of the Skipton Waterworks Trust be increased by adding to the same the lands shown by red border and red colour respectively on the plan approved by the Governor in Council and deposited in the office of the State Rivers and Water Supply Commission, Melbourne (Corr. No. 59/2666/131) as on and from the date hereof, the extent of such districts shall be and be deemed to be increased accordingly.

And the Honorable Frederick James Granter, Her Majesty's Minister of Water Supply for the State of Victoria, shall give the necessary directions herein accordingly.

TOM FORRISTAL
Clerk of the Executive Council

WATER ACT 1958

At the Executive Council Chamber, Melbourne, the
sixth day of May, 1980

PRESENT:

His Excellency the Governor of Victoria
Mr Balfour | Mr Lieberman
Mr Lacy

EAST LODDON WATERWORKS DISTRICT—PORTION
EXCISED

Under the powers conferred by the Water Act 1958 and all other powers enabling him in that behalf, His Excellency the Governor of the State of Victoria, with the advice of the Executive Council of the said State, on the recommendation of the State Rivers and Water Supply Commission, doth hereby declare, order and direct that there shall be excised from the East Loddon Waterworks District that portion of the same shown by green colour on a plan approved by the Governor in Council and deposited in the office of the State Rivers and Water Supply Commission at 590 Orrong Road, Armadale (Corr. No. 71/1031) and as on and from 31 May 1980, such portion shall be deemed to be excised accordingly.

And the Honorable Frederick James Granter, Her Majesty's Minister of Water Supply for the State of Victoria, shall give the necessary directions herein accordingly.

TOM FORRISTAL
Clerk of the Executive Council

WATER ACT 1958

At the Executive Council Chamber, Melbourne, the
sixth day of May, 1980

PRESENT:

His Excellency the Governor of Victoria
Mr Balfour | Mr Lieberman
Mr Lacy

KERANG NORTH-WEST LAKES WATERWORKS
DISTRICT—PORTION EXCISED

Under the powers conferred by the Water Act 1958 and all other powers enabling him in that behalf, His Excellency the Governor of the State of Victoria, with the advice of the Executive Council of the said State, on the recommendation of the State Rivers and Water Supply Commission, doth hereby declare, order and direct that there shall be excised from the Kerang North-West Lakes Waterworks District that portion of the same shown by green colour on a plan approved by the Governor in Council and deposited in the office of the State Rivers and Water Supply Commission at 590 Orrong Road, Armadale (Corr. No. 64/946) and as on and from 31 May 1980, such portion shall be deemed to be excised accordingly.

And the Honorable Frederick James Granter, Her Majesty's Minister of Water Supply for the State of Victoria, shall give the necessary directions herein accordingly.

TOM FORRISTAL
Clerk of the Executive Council

SEWERAGE DISTRICTS ACT

At the Executive Council Chamber, Melbourne, the
sixth day of May, 1980

PRESENT:

His Excellency the Governor of Victoria
Mr Balfour | Mr Lieberman
Mr Lacy

TRANSFER OF WORKS FROM THE UPPER YARRA SHIRE COUNCIL TO THE UPPER YARRA SEWERAGE AUTHORITY AND ADJUSTMENT OF LIABILITIES

Whereas:

A. By an Order in Council dated 17 July 1979 made under the provisions of the *Sewerage Districts Act 1958* ("the Act") and published in the *Government Gazette* of 18 July 1979 the Governor in Council constituted a Sewerage Authority under the corporate name of the Upper Yarra Sewerage Authority ("the Authority").

B. Under the provisions of section 19B of the Act:

- (1) A public authority (including a municipal council) may agree with a Sewerage Authority for the transfer of works from the public authority to the Authority.
- (2) The Governor in Council may, upon the application of the public authority and the Authority concerned by an Order or Orders published in the *Government Gazette*—
 - (a) transfer any land easements works property powers rights liabilities and obligations agreed to be transferred pursuant to the agreement; and
 - (b) adjust the respective liabilities of the public authority and the Authority in such manner as he thinks fit in consequence of the transfer of the said land easements works property powers rights liabilities and obligations.

C. The Upper Yarra Shire Council ("the Council") and the Authority have agreed by resolutions made at their respective meetings both held on 19 March 1980 to transfer from the Council to the Authority the sewerage works referred to in this order.

Now therefore His Excellency the Governor of the State of Victoria, by and with the advice of the Executive Council of the said State, and pursuant to the herein recited powers of the Act, doth hereby declare, order and direct that as on and from the date of this Order ("the operative date"):

- (1) There shall be transferred from the Council to the Authority:
 - (a) the ownership of all the sewerage works constructed to serve all that piece of land known as the Yarraview Estate which land is more particularly described in section 3 of the *Sewerage Districts (Transfer of Works) Act 1978* (No. 9241) to the intent that those works shall be continued, operated and maintained by the Authority;
 - (b) all rights and liabilities in any lands or easements owned by, vested in, or existing in favour of, the Council in respect of the sewerage works; and
 - (c) all powers, obligations and rights of the Council in respect of the sewerage works.
- (2) There shall be adjusted, in consequence of the transfers aforesaid, the respective liabilities of the Council and the Authority by transferring the actual net liability shown in the books of the Council as at the operative date in respect of the works, lands, easements and rights hereby transferred (being the amount of One Hundred and Ninety-Nine Thousand Eight Hundred and Eighty-Six Dollars and Thirty-Six Cents (\$199 886.36)) from the books of the Council to the books of the Authority to the intent that such amount shall as on and from the operative date be the responsibility of the Authority.

- (3) The Authority shall construct, operate, maintain and continue sewerage works for the service of the Yarraview Estate.

And the Honorable Frederick James Granter, Her Majesty's Minister of Water Supply for the State of Victoria, shall give the necessary directions herein accordingly.

TOM FORRISTAL
Clerk of the Executive Council

CAMPERDOWN SEWERAGE AUTHORITY

At the Executive Council Chamber, Melbourne, the
sixth day of May, 1980

PRESENT:

His Excellency the Governor of Victoria
Mr Balfour | Mr Lieberman
Mr Lacy

APPROVAL OF EXTENSION OF TREATMENT WORKS SITE AND ACQUISITION OF LAND

Under the powers conferred by the *Sewerage Districts Act* and all other powers enabling him in that behalf, His Excellency the Governor of the State of Victoria, by and with the advice of the Executive Council of the said State, doth hereby approve of—

- (a) the extension of the treatment works site as shown by red colour on a plan approved by the Governor in Council and deposited in the office of the State Rivers and Water Supply Commission, Melbourne (Corr. No. 63/5065/165); and
- (b) the acquisition by the Camperdown Sewerage Authority of the land required for the extension of the treatment works site.

And the Honorable Frederick James Granter, Her Majesty's Minister of Water Supply for the State of Victoria, shall give the necessary directions herein accordingly.

TOM FORRISTAL
Clerk of the Executive Council

LOCAL GOVERNMENT ACT 1958

At the Executive Council Chamber, Melbourne, the
thirteenth day of May, 1980

PRESENT:

His Excellency the Governor of Victoria
Mr Borthwick | Mr Smith
Mr Dixon | Mr Granter

SEVERANCE AND ANNEXATION FROM SHIRE OF HEALESVILLE TO THE SHIRE OF YEA

Pursuant to the provisions of Part II. of the *Local Government Act 1958*, His Excellency the Governor of the State of Victoria, by and with the advice of the Executive Council thereof, hereby orders:—

1. That the portion of the municipal district of the Shire of Healesville described hereunder shall be severed therefrom and annexed to the Shire of Yea;
2. That no Councillor of the Shire of Healesville or the Shire of Yea shall go out of office other than in accordance with the provisions of Division 2 of Part III. of the *Local Government Act 1958*; and
3. That for the purposes of elections of councillors, this Order shall take effect on and from 19 May 1980 and for all other purposes on and from 1 October 1980.

Portion of the West Riding of the Shire of Healesville to be severed therefrom and annexed to the Shire of Yea.

Commencing at the south-western angle of allotment 5, section B, Parish of Kinglake; thence northerly by the road forming the western boundary of that allotment to the northern boundary of the County of Evelyn; thence generally north-easterly by that boundary to the south-eastern angle of allotment 44A; thence further north-easterly by the northern boundary of the County of Evelyn to a point where it is intersected by the Healesville-Kinglake Road; thence generally south-westerly by that road to its junction with the road from Yarra Glen to Mount Slide Junction; thence generally south-westerly by the last mentioned road to the most eastern angle of allotment 26; thence generally south-westerly by the southern boundary of that allotment and further south-westerly by a line to the most southern angle of allotment 25; thence north-westerly by the south-western boundaries of allotments 25 and 24 and south-westerly by the south-eastern boundaries of allotments 14 and 13 to the most eastern angle of allotment 5; and thence south-westerly and westerly by the south-eastern and southern boundaries of that allotment to the point of commencement.

And the Honorable Digby Glen Crozier, Her Majesty's Minister for Local Government for the State of Victoria, shall give the necessary directions herein accordingly.

TOM FORRISTAL
Clerk of the Executive Council

LOCAL GOVERNMENT DEPARTMENT

At the Executive Council Chamber, Melbourne, the thirteenth day of May, 1980

PRESENT:

His Excellency the Governor of Victoria	
Mr Borthwick	Mr Smith
Mr Dixon	Mr Granter

RE-SUBDIVISION OF THE CITY OF BROADMEADOWS

Pursuant to the provisions of Part II of the *Local Government Act 1958*, His Excellency the Governor of the State of Victoria, by and with the advice of the Executive Council thereof, hereby orders:—

1. That the municipal district of the City of Broadmeadows shall be re-subdivided in the manner described;
2. That all councillors shall go out of office on the day appointed for the election of councillors next after this Order takes effect; and
3. That for the purposes of elections of councillors this Order shall take effect on and from 19 May 1980 and for all other purposes on and from 1 October 1980.

CITY OF BROADMEADOWS

Broadmeadows Ward

(Enlarged and Re-defined)

Commencing at a point on the northern boundary of the City where it is intersected by the North Eastern Railway; thence southerly by that railway to the point where it is intersected by a State Electricity Commission of Victoria easement at the Jacana Railway Station; thence south-westerly by that easement to the Moonee Ponds Creek; thence generally southerly by that creek to its intersection with the Albion and Broadmeadows Railway being a point on the boundary of the City; thence south-westerly, north-westerly, northerly, easterly, northerly, easterly, northerly and easterly by that boundary to the point of commencement.

Campbellfield Ward

(Reduced and Re-defined)

Commencing at a point on the southern boundary of the City where it is intersected by the Coburg and Somerton Railway; thence north-westerly by that railway and northerly by the North Eastern Railway to the northern bound-

ary of the city; and thence easterly, generally southerly and westerly by the city boundary to the point of commencement.

Glenroy Ward

(Enlarged and Re-defined)

Commencing at a point on the southern boundary of the City where it is intersected by the Coburg and Somerton Railway; thence north-westerly by that railway to Box Forest Road; thence westerly by Box Forest Road, Hilton Street and a line to the North Eastern Railway; thence northerly by that railway to the point where it is intersected by a State Electricity Commission of Victoria easement at the Jacana Railway Station; thence south-westerly by that easement to the Moonee Ponds Creek; thence generally southerly by that creek to its intersection with the Albion and Broadmeadows Railway being a point on the boundary of the City; thence south-easterly, easterly, northerly and easterly by that boundary to the point of commencement.

Somerton Ward

(Reduced and Re-defined)

Commencing at the intersection of Box Forest Road and the Coburg and Somerton Railway; thence westerly by Box Forest Road, Hilton Street and a line in continuation thereof to the North Eastern Railway; thence northerly by that railway to its junction with the Coburg and Somerton Railway; and thence south-easterly by the Coburg and Somerton Railway to the point of commencement.

And the Honorable Digby Glen Crozier, Her Majesty's Minister for Local Government for the State of Victoria, shall give the necessary directions herein accordingly.

TOM FORRISTAL
Clerk of the Executive Council

LOCAL GOVERNMENT ACT 1958

At the Executive Council Chamber, Melbourne, the thirteenth day of May, 1980

PRESENT:

His Excellency the Governor of Victoria	
Mr Borthwick	Mr Smith
Mr Dixon	Mr Granter

RE-SUBDIVISION OF THE CITY OF MALVERN

Pursuant to the provisions of Part II of the *Local Government Act 1958*, His Excellency the Governor of the State of Victoria, by and with the advice of the Executive Council thereof, hereby orders:

1. that the municipal district of the City of Malvern shall be re-subdivided in the manner described hereunder;
2. that all councillors shall go out of office on the day appointed for the annual election of councillors next after this Order takes effect; and
3. that for the purposes of elections of councillors this order shall take effect on and from 19 May 1980 and for all other purposes on and from 1 October 1980.

CITY OF MALVERN

NORTH WARD

(Reduced and Re-defined)

(Previous Gazette 1902.1955)

Commencing at a point on the western boundary of the City where it is intersected by High Street; thence easterly by High Street to Glenferrie Road; thence northerly by Glenferrie Road to Malvern Road; thence easterly by Malvern Road to Tooronga Road; thence southerly by Tooronga Road to High Street; thence easterly by High Street to Burke Road; thence northerly by Burke Road to the City boundary and thence generally north-westerly and southerly by that boundary to the point of commencement.

SOUTH WARD

*(Enlarged and Re-defined)**(Previous Gazettal 1902.1955)*

Commencing at a point on the western boundary of the City where it is intersected by High Street; thence easterly by High Street to Glenferrie Road; thence northerly by Glenferrie Road to Malvern Road; thence easterly by Malvern Road to Tooronga Road; thence southerly by Tooronga Road to the City boundary and thence generally north-westerly and northerly by that boundary to the point of commencement.

CENTRAL WARD

*(Enlarged and Re-defined)**(Previous Gazettal 1902.1955)*

Commencing at a point on the northern boundary of the City where it is intersected by Burke Road; thence southerly by Burke Road to High Street; thence westerly by High Street to Tooronga Road; thence southerly by Tooronga Road to Dandenong Road; thence south-easterly and easterly by Dandenong Road and Waverley Road to Darling Road; thence northerly by Darling Road to Malvern Road; thence north-westerly by Malvern Road to Moira Street; thence north-easterly by Moira Street to its intersection with the Burnley to Oakleigh Junction Railway; thence north-westerly by that railway to its intersection with High Street; thence easterly by High Street to the City boundary and thence generally north-westerly by that boundary to the point of commencement.

EAST WARD

*(Reduced and Re-defined)**(Previous Gazettal 1902.1955)*

Commencing at a point on the northern boundary of the City where it is intersected by High Street; thence westerly by High Street to its intersection with the Burnley to Oakleigh Junction Railway; thence south-easterly by that railway to its intersection with Moira Street; thence south-westerly by Moira Street to Malvern Road; thence south-easterly by Malvern Road to Darling Road; thence southerly by Darling Road to Waverley Road; thence westerly by Waverley Road to the City boundary and thence generally south-easterly, northerly and generally south-westerly and north-westerly by that boundary to the point of commencement.

And the Honorable Digby Glen Crozier, Her Majesty's Minister for Local Government for the State of Victoria, shall give the necessary directions herein accordingly.

TOM FORRISTAL
Clerk of the Executive Council

LOCAL GOVERNMENT ACT 1958

At the Executive Council Chamber, Melbourne, the
thirteenth day of May, 1980

PRESENT:

His Excellency the Governor of Victoria

Mr Borthwick
Mr DixonMr Smith
Mr Granter

RE-SUBDIVISION OF THE MUNICIPAL DISTRICT OF THE SHIRE OF STAWELL

Pursuant to the provisions of Part II. of the *Local Government Act 1958*, His Excellency the Governor of the State of Victoria, by and with the advice of the Executive Council thereof hereby orders:—

- (1) that the municipal district of the Shire of Stawell shall be re-subdivided in the manner described hereunder;
- (2) that no councillor shall go out of office other than in accordance with the provisions of Division 2 of Part III. of the *Local Government Act 1958*; and
- (3) that for the purposes of elections of councillors, this order shall take effect on and from 19 May 1980 and for all other purposes on and from 1 October 1980.

No. 34—20690/80—3

SHIRE OF STAWELL

North-East Riding

*(Enlarged and Re-defined)**(Previous Gazettal 1954.206)*

Commencing on the north-western boundary of the Shire at the south-western angle of allotment 191, Parish of Wirchilleba; thence easterly by the southern boundary of that parish and southerly by the western boundaries of the Parishes of Wallaloo, Bolangum and Glynwylln to the Wimmera River; thence generally easterly by the Wimmera River to the Navarre Road; thence generally easterly, northerly, north-easterly and easterly by that road to the eastern boundary of the shire at the eastern angle of allotment 207A, Parish of Navarre; and thence generally north-westerly and south-westerly by the shire boundary to the point of commencement.

North Riding

*(Reduced and Re-defined)**(Previous Gazettal 1954.206)*

Commencing on the north-western boundary of the shire at the south-western angle of allotment 191, Parish of Wirchilleba; thence easterly by the southern boundary of that parish and southerly by the western boundaries of the Parishes of Wallaloo, Bolangum and Glynwylln to the south-western angle of allotment 129H in the last named parish; thence south-westerly and south-easterly by a 60.35 metre road to the south-eastern angle of allotment 186a2, Parish of Kirkella; thence westerly by the southern boundaries of the Parishes of Kirkella and Gampola to the south-western angle of allotment 2 in the latter parish; thence generally northerly by the Stawell-Warracknabeal Road to the south-western boundary of allotment 86, Parish of Gampola; thence north-westerly by that boundary and generally north-westerly by the Wimmera River to a point on the west boundary of the shire where the road forming part of the northern boundary of the Parish of Ledcourt abuts thereon; and thence generally north-westerly and easterly by the shire boundary to the point of commencement.

East Riding

*(Enlarged and Re-defined)**(Previous Gazettal 1954.206)*

Commencing on the eastern boundary of the Shire at the eastern angle of allotment 207A, Parish of Navarre; thence south-westerly by the Navarre Road to the Wimmera River; thence generally westerly by that river to the western boundary of the Parish of Glynwylln; thence southerly by that boundary to the south-western angle of allotment 129H; thence south-westerly and south-easterly by a 60.35 metre road to the south-eastern angle of allotment 186a2, Parish of Kirkella; thence westerly by the southern boundary of that parish to the north-western angle of allotment 214; Parish of Illawarra; thence generally southerly by the eastern boundary of the Permanent Forest Reserve to the northern boundary of the Municipality of the Town of Stawell; thence easterly and southerly by the northern and eastern boundaries of that municipality to the Western Highway; thence south-easterly by that highway to the northern angle of allotment 6A, section 3, Parish of Concongella South; thence south-westerly by the western boundary of that parish to the southern boundary of the shire; and thence generally easterly, northerly and westerly by the shire boundary to the point of commencement.

West Riding

*(Reduced and Re-defined)**(Previous Gazettal 1954.206)*

Commencing at a point on the Wimmera River where the road forming part of the northern boundary of the Parish of Ledcourt abuts thereon and being on the western boundary of the shire; thence generally south-easterly by that river to the road forming part of the south-western boundary of allotment 86, Parish of Gampola; thence generally south-easterly by that road and the Stawell-Warracknabeal Road to the south-western angle of allotment 2 in the said parish; thence easterly by the southern boundaries of the Parishes of Gampola and Kirkella to the north-western angle of allotment 214, Parish of Illawarra; thence generally southerly by the eastern boundary of the

Permanent Forest Reserve to the northern boundary of the Municipality of the Town of Stawell; thence westerly, southerly and easterly by the northern, western and southern boundaries of that municipality to the Western Highway; thence south-easterly by that highway to the northern angle of allotment 6A, section 3, Parish of Congella South; thence south-westerly by the western boundary of that parish to the southern boundary of the shire; and thence generally westerly, southerly, westerly and northerly by the shire boundary to the point of commencement.

And the Honorable Digby Glen Crozier, Her Majesty's Minister for Local Government for the State of Victoria, shall give the necessary directions herein accordingly.

TOM FORRISTAL
Clerk of the Executive Council

LATROBE VALLEY WATER AND SEWERAGE BOARD

At the Executive Council Chamber, Melbourne, the thirteenth day of May, 1980

PRESENT:

His Excellency the Governor of Victoria	
Mr Borthwick	Mr Smith
Mr Dixon	Mr Granter

CONSENT TO BORROWING \$100 000

Under the powers conferred by the Latrobe Valley Water and Sewerage Act and all other powers enabling him in that behalf, His Excellency the Governor of the State of Victoria, by and with the advice of the Executive Council of the said State, hereby consents to the Latrobe Valley Water and Sewerage Board borrowing the sum of One hundred thousand dollars (\$100 000) to meet the cost of water supply and sewerage works.

And the Honorable Frederick James Granter, Her Majesty's Minister of Water Supply for the State of Victoria, shall give the necessary directions herein accordingly.

TOM FORRISTAL
Clerk of the Executive Council

SHIRE OF CRANBOURNE SEWERAGE AUTHORITY

At the Executive Council Chamber, Melbourne, the thirteenth day of May, 1980

PRESENT:

His Excellency the Governor of Victoria	
Mr Borthwick	Mr Smith
Mr Dixon	Mr Granter

CONSENT TO BORROWING \$50 000

Under the powers conferred by the Sewerage Districts Act and all other powers enabling him in that behalf, His Excellency the Governor of the State of Victoria, by and with the advice of the Executive Council of the said State, hereby consents to the Shire of Cranbourne Sewerage Authority borrowing the sum of Fifty thousand dollars (\$50 000) to meet the cost of sewerage works as set forth in the detailed statement bearing date 8 May 1980.

And the Honorable Frederick James Granter, Her Majesty's Minister of Water Supply for the State of Victoria, shall give the necessary directions herein accordingly.

TOM FORRISTAL
Clerk of the Executive Council

FOSTER SEWERAGE AUTHORITY

At the Executive Council Chamber, Melbourne, the thirteenth day of May, 1980

PRESENT:

His Excellency the Governor of Victoria	
Mr Borthwick	Mr Smith
Mr Dixon	Mr Granter

CONSENT TO BORROWING \$40 000

Under the powers conferred by the Sewerage Districts Act and all other powers enabling him in that behalf, His Excellency the Governor of the State of Victoria, by and with the advice of the Executive Council of the said State, hereby consents to the Foster Sewerage Authority borrowing the sum of Forty thousand dollars (\$40 000) to meet the cost of sewerage works as set forth in the detailed statement bearing date 8 May 1980.

And the Honorable Frederick James Granter, Her Majesty's Minister of Water Supply for the State of Victoria, shall give the necessary directions herein accordingly.

TOM FORRISTAL
Clerk of the Executive Council

MALLACOOTA SEWERAGE DISTRICT PROCLAIMED MALLACOOTA SEWERAGE AUTHORITY CONSTITUTED

At the Executive Council Chamber, Melbourne, the thirteenth day of May, 1980

PRESENT:

His Excellency the Governor of Victoria	
Mr Borthwick	Mr Smith
Mr Dixon	Mr Granter

His Excellency the Governor of the State of Victoria, by and with the advice of the Executive Council thereof doth hereby approve in accordance with the provisions of the Sewerage Districts Act of the proclamation of a Sewerage District and Constitution of a Sewerage Authority for the construction, maintenance and continuance of sewerage works at Mallacoota as set out in the Application of the Commissioners of the Mallacoota Waterworks Trust and doth hereby order and appoint as follows:—

1. That the principal works to be constructed or carried out shall consist of reticulation sewers, manholes, main sewers, pumping stations, rising mains and treatment and disposal works.

2. That the estimated cost of carrying out the works is \$1 033 900.

3. That the lands within the boundary shown in red colour on the Plan accompanying this Order are hereby proclaimed to be the Sewerage District (to be known as the Mallacoota Sewerage District) such Sewerage District being wholly within the Shire of Orbost.

4. That a Sewerage Authority is hereby constituted and its corporate name shall be the Mallacoota Sewerage Authority.

5. That the members of the said Sewerage Authority shall comprise the Commissioners for the time being of the Mallacoota Waterworks Trust.

The boundaries of the said Sewerage District are shown on the Plan approved by the Governor in Council by and with this Order and deposited in the Office of the State Rivers and Water Supply Commission, Melbourne (72/1664/101).

And the Honorable Frederick James Granter, Her Majesty's Minister of Water Supply for the State of Victoria, shall give the necessary directions herein accordingly.

TOM FORRISTAL
Clerk of the Executive Council

SUNBURY SEWERAGE AUTHORITY

At the Executive Council Chamber, Melbourne, the
thirteenth day of May, 1980

PRESENT:

His Excellency the Governor of Victoria	
Mr Borthwick	Mr Smith
Mr Dixon	Mr Granter

CONSENT TO BORROWING \$72 000

Under the powers conferred by the Sewerage Districts Act and all other powers enabling him in that behalf, His Excellency the Governor of the State of Victoria, by and with the advice of the Executive Council of the said State, hereby consents to the Sunbury Sewerage Authority borrowing the sum of Seventy-two thousand dollars (\$72 000) to meet the cost of sewerage works as set forth in the detailed statement bearing date 8 May 1980.

And the Honorable Frederick James Granter, Her Majesty's Minister of Water Supply for the State of Victoria, shall give the necessary directions herein accordingly.

TOM FORRISTAL
Clerk of the Executive Council

RACING ACT 1958

At the Executive Council Chamber, Melbourne, the
thirteenth day of May, 1980

PRESENT:

His Excellency the Governor of Victoria	
Mr Borthwick	Mr Smith
Mr Dixon	Mr Granter

His Excellency the Governor of the State of Victoria, in the Commonwealth of Australia, by and with the advice of the Executive Council of the said State, and in pursuance of the powers conferred by the Racing Act 1958 and all other powers him thereunto enabling, doth by this Order appoint:

HUGH MITCHELL MCKENZIE, being a person nominated by the governing body of the Moonee Valley Racing Club; to be a member of the Totalizator Agency Board for a term of three years from 1 June 1980.

And the Honorable Brian James Dixon, Her Majesty's Minister for Youth, Sport and Recreation for the State of Victoria, shall give the necessary directions herein accordingly.

TOM FORRISTAL
Clerk of the Executive Council

FRUIT AND VEGETABLES ACT 1958

At the Executive Council Chamber, Melbourne, the
thirteenth day of May, 1980

PRESENT:

His Excellency the Governor of Victoria	
Mr Borthwick	Mr Smith
Mr Dixon	Mr Granter

Under the powers conferred by section 48 of the Fruit and Vegetables Act 1958, His Excellency the Governor of the State of Victoria, by and with the advice of the Executive Council thereof doth hereby authorize the person named hereunder, who is an Inspector under the

said Act, to take proceedings in respect of offences against Part II. of the said Act or the Regulations thereunder.

KEITH WALTER BLACKMORE

And the Honorable Ian Winton Smith, Her Majesty's Minister of Agriculture for the State of Victoria, shall give the necessary directions herein accordingly.

TOM FORRISTAL
Clerk of the Executive Council

COAL MINES ACT 1958

At the Executive Council Chamber, Melbourne, the
thirteenth day of May, 1980

PRESENT:

His Excellency the Governor of Victoria	
Mr Borthwick	Mr Smith
Mr Dixon	Mr Granter

CHANGES IN RATES OF PENSIONS PAYABLE UNDER PART III. OF COAL MINES ACT 1958

Whereas it is provided in section 110 of the Coal Mines Act 1958 that whenever rates of Commonwealth pensions are increased, rates of pensions payable under Part III. of the Coal Mines Act 1958 shall be increased and that whenever rates of pensions are increased by the operation of that provision the Governor in Council may, by Order published in the Government Gazette, declare those rates to be the rates payable under the said Part.

And whereas rates of Commonwealth pensions have been increased from 8 May 1980.

Now therefore, I, the Governor of the State of Victoria, by and with the advice of the Executive Council thereof, do by this Order declare the rates of pension shown hereunder to be the rates of pension payable under the several provisions of the said Part.

\$66.30, section 104
\$66.30, section 105
\$43.40, paragraphs (a) and (c) of section 106
\$7.50, paragraph (b) of section 106
\$65.30, sub-sections (1) and (1A) of section 107.

And the Honorable James Charles Murray Balfour, Her Majesty's Minister for Minerals and Energy for the State of Victoria, shall give the necessary directions herein accordingly.

TOM FORRISTAL
Clerk of the Executive Council

**LANDS DEPARTMENT
NOTICES**

APPROACHING LAND SALES

Sale of Crown Land, will be held at the under-mentioned places and dates, viz.:—

	No. of Gazette
Goroke, Monday, 2 June 1980	29

SALE OF FREEHOLD LAND BY AUCTION	
Swan Hill, Monday, 23 June 1980	29

COMMITTEE OF MANAGEMENT "STATE SWIMMING CENTRE" RECREATION RESERVE CITY OF MELBOURNE

In pursuance of section 14 of the Crown Land (Reserves) Act 1978, I hereby appoint the following persons as a Committee of Management for a period of three (3) years of the land in the City of Melbourne, Parish of

Melbourne North, temporarily reserved for Recreation purposes by Order in Council of 8 May 1979 (vide *Government Gazette* dated 16 May 1979):

BRIAN EUSTACE and GEOFFREY HARE (for so long only as they shall continue to be the nominees of the Victorian Amateur Swimming Association);

PERRY ROTHROCK CROSSWHITE and DAVID MAZITELLI (for so long only as they shall continue to be the nominees of the Department of Youth, Sport and Recreation); and

BERT ANDREW JELICOE KEDDIE, who shall be Chairman.—(Rs.10842).

W. V. HOUGHTON
Minister of Lands

Department of Crown Lands and Survey
Melbourne, 12 May 1980

PROPOSED REVOCATION OF TEMPORARY RESERVATIONS OF LANDS BY ORDERS IN COUNCIL

In pursuance of the provisions of Section 10 of the *Crown Land (Reserves) Act 1978*, notice is hereby given that it is the intention of the Governor in Council to revoke the temporary reservations of lands by Orders in Council hereunder referred to, viz.:-

MANGALORE—The temporary reservation by Order in Council of 17 September 1957 of 63.76 hectares of land in the Parish of Mangalore (adjoining Crown allotments 26B, 27 and 33A) as a site for Supply of Gravel—(Rs.7665).

SALE AND WURRUK WURRUK—The temporary reservation by Order in Council of 8 January 1980 of 9000 square metres, more or less, of land being Crown allotment 2B, section A, Parish of Sale, and Crown allotments 41G and 41H, Parish of Wurruk Wurruk, for the Preservation of Species of Native Plants—(S.242(12) (W.225(*) (Rs.10737).

BOLWARRA—The temporary reservation by Order in Council of 19 January 1917 of 147.6 hectares of land in the Parish of Bolwarra (formerly Parishes of Bolwarra and Gorae) in section 2, as a site for a Quarry for the use of the Department of Public Works, revoked as to part by various Orders, so far as the balance thereof containing 120.9 hectares, more or less, is concerned—(Rs.1429).

MOORPANYAL—The temporary reservation by Order in Council of 23 November 1868 of 10.11 hectares, more or less, of land in the Parish of Moorpanyal as a site for Geelong Cattle Market, revoked as to part by various Orders and pursuant to the *Balmoral Geelong and Balwyn Lands Exchange Act 1964*, so far only as the portion thereof containing 1.167 hectares, as indicated by hatching on plan hereunder, is concerned—(Plan 3179) (C.73694).

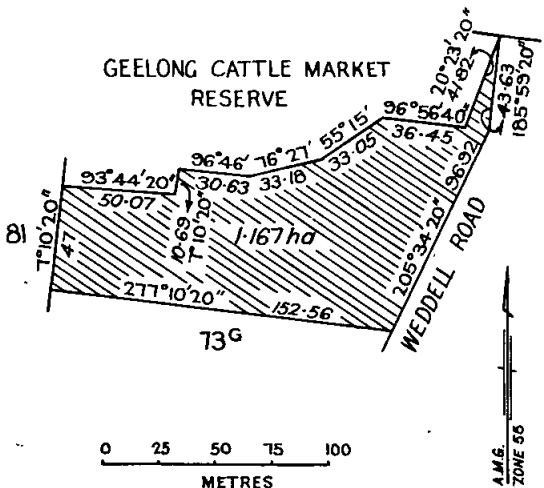

W. V. HOUGHTON
Minister of Lands

**VENTNOR CAMPING RESERVE
REGULATIONS**

I, William Vasey Houghton, Her Majesty's Minister of Lands in and for the State of Victoria, in pursuance of the powers conferred on me by section 13 of the *Crown Land (Reserves) Act 1978*, do hereby make the following Regulations for or with respect to the Crown land in the Township of Ventnor, Parish of Phillip Island, (hereinafter referred to as the "Reserve") temporarily reserved as a site for Camping Purposes by Order in Council dated 14 March 1979 (vide *Government Gazette* of 21 March 1979):—

1. No person in the Reserve shall behave in a noisy or disorderly manner, or create or take part in any disturbance, or commit any act of indecency, or offend against decency as regards dress, language or conduct.

2. No person shall place in the Reserve any cattle, horses, sheep, goats, pigs, or other animals, except as hereinafter provided, without the permission, in writing, of the Committee first obtained.

3. No person shall discharge any gun, pistol, rifle, air gun or any firearm or other offensive weapon in or upon the Reserve.

4. No person shall in or upon the Reserve kill, wound, trap, or snare, or attempt to kill, wound, trap, or snare any bird, kangaroo, wallaby, wombat, kangaroo rat, echidna, platypus or other native game, or have any dead bird, kangaroo, wallaby, wombat, kangaroo rat, echidna, platypus or other native game or the skin or pelt thereof, in his possession.

5. No person shall—
(a) cut down, ring-bark, destroy, or damage any tree or plant growing on the Reserve;
(b) dig, cut, or remove any turf, sod, loam, sand, or gravel or other substance in or on the Reserve.

6. No person shall light a fire in the Reserve except in any place set apart for that purpose by the Committee, and no person shall leave any fire which has been lighted by him until such fire has been thoroughly extinguished. No refuse material shall be burnt on the Reserve except by a representative of the Committee.

7. No person shall climb on or jump over any of the gates or fences in or around the Reserve, stick bills thereon, or cut names on or in any way damage or injure any of the buildings, gates, fences, seats, or trees in the Reserve, nor leave or deposit any glass, paper, or other rubbish except in any receptacles provided, nor roll or throw stones or any missiles of any kind therein.

8. No person shall erect any tent, booth, stand, building, or other structure in the Reserve without the permission of the Committee or its representative, and any such tent, booth, stand, building, or other structure shall be erected only on the site allotted by the Committee or its representative.

9. No person shall bring into the Reserve any dog unless such dog is at all times controlled by a chain, cord, or leash.

10. The Committee shall have power, from time to time, to fix and regulate the fees to be paid for the use of this Reserve.

11. A charge fixed by the Committee may be made for the admission of any car or vehicle to the Reserve.

12. The Committee shall have power and authority to impound any cattle found trespassing on the Reserve and shall be taken to be the occupier of the Reserve (with all power incidental to that status) within the meaning of any law for the time being in force relating to the impounding of cattle.

13. No person shall obstruct, disturb, interrupt, or annoy any officer or employee of the Committee in the proper execution of his work and duty—(Rs.10443).

Given under my hand at Melbourne on 5 May 1980.

W. V. HOUGHTON
Minister of Lands

Every person who contravenes or fails to comply with these Regulations shall be liable to the penalties prescribed in section 13 of the *Crown Land (Reserves) Act 1978*.

TENDERS

PUBLIC WORKS DEPARTMENT

Tenders are invited for the purposes indicated hereunder and will be received at 2 Treasury Place, Melbourne, 3002, until **TWO** p.m. on dates shown.

Tenders must be addressed to the Minister of Public Works with the envelope endorsed "Tender for

". Hand-delivered tenders must be placed in the Department's tender box in the foyer, Ground Floor, 2 Treasury Place, Melbourne.

Tenders documents are available from the Contracts Office, Room 29, 2 Treasury Place, Melbourne, and where indicated, at offices of Inspectors of Works.

★Tenders for works identified with star (★) will only be considered from Contractors qualified for repairs and painting works. Any Tenderers wishing to qualify may obtain the application form from the Contracts Office.

Tuesday, 27 May 1980

Building, Electrical and Mechanical Works

BALLARAT—Cyclic maintenance, painting to junior school, science wing, Sheehan Wing, High School. (W.O., Ballarat.)

BROADMEADOWS—Renewal of water supply and extension of fire service, Technical School.

BUNDOORA—Completion of library works, Greenwood High School.

CHELSEA (Re-advertisement, Amended Specification)—Alterations and additions to existing building, Yarrabah Special Development School.

CHELSEA (Re-advertisement, Amended Specification)—Alterations and additions to existing building, mechanical services, Yarrabah Special Development School.

COCKATOO—New freestanding library with covered play area under and associated site development works, Primary School.

COCKATOO—New freestanding library with covered play area under and associated site development works, electrical works, Primary School.

COCKATOO—New freestanding library with covered play area under and associated site development works, mechanical services, Primary School.

CROYDON SOUTH—Exterior and part interior repairs and painting, Primary School No. 4890.

EASTWOOD—Exterior and interior repairs and painting, Primary School No. 4702.

ESSENDON—Repairs, internal and external repairs, painting and alterations, Primary School.

★**FRANKSTON** (Re-advertisement)—External repairs and painting, High School. (W.O., Dandenong.)

GOLDEN POINT—Internal and external repairs and painting, Primary School. (W.O., Ballarat.)

MELBOURNE—Building works, storage shed, No. 8 North Wharf.

MITCHAM—Alterations and Extensions to existing Special School No. S.S. 4871, including associated site works and services, Special School.

NORTH MELBOURNE—External renovations, Primary School No. 1402.

SPEED—Additions and alterations to bathroom, laundry area, Police Station/Residence. (W.O., Swan Hill.)

ST. ALBANS—Replacement of fire service, Technical School.

SUNBURY—Cyclic maintenance, laundry and sewing room, Training Centre.

TONGALA—Roof renovations and various minor repairs, Consolidated School. (W.O., Bendigo and Shepparton.)

★**WHITESIDE**—External repairs and painting, Primary School.

YARRABAH (Amended Specification)—Alterations and additions to existing building, Electrical Services.

Site Works

GLEN WAVERLEY—Scoria pavement and relocation of sprinklers, Police Academy.

NEWPORT—Site works, Primary School No. 113.

TOTTENHAM—Site works, stage 2, Primary School No. 4707.

Miscellaneous

BALLARAT—Supply and installation of interconnecting movable screens, State Public Offices.

KEW—Maintenance cleaning period 1 July 1980 to 30 June 1983, Soil Conservation Authority.

PORT MELBOURNE—Supply of 5000 coir mats, P.W.D. Storeyard.

Tuesday, 3 June 1980

Building, Electrical and Mechanical Works

★**AMSTEL**—External repairs and painting, Primary School. (W.O., Dandenong.)

BRIAR HILL—Internal and external renovations, Primary School.

COLERAINE—Supply and delivery of 1 No. relocatable modular residence, F.O.G. Salmon Street, Port Melbourne, Police Residence Relocatable. (W.O., Geelong, Ballarat, Bendigo, Wangaratta, Benalla and Traralgon.)

IRYMPLE SOUTH (Re-advertisement, Amended Specification)—New toilets, staff and administration upgrade and servicing of relocatable classrooms, Primary School. (W.O., Mildura.)

IRYMPLE SOUTH (Re-advertisement)—Mechanical Services, new toilets, staff and administration upgrade and relocatable classrooms, Primary School. (W.O., Swan Hill and Mildura.)

★**LILYDALE**—Exterior and minor interior renovations, High School.

MANANGATANG (Re-advertisement)—Erection of relocatable complex and associated works, Consolidated School. (W.O., Bendigo and Swan Hill.)

MITCHAM—Alterations and extensions to existing Special School No. S.S. 4871, Mechanical Services, Special School.

★**MOOROOLBARK**—External and minor internal renovations, Technical School.

Site Works

BROOKLYN—Site works (pavements), Primary School No. 4710.

Miscellaneous

NEWPORT—Supply of electrical trades equipment, Technical College, Stage II.

VARIOUS—Supply of domestic equipment, 1 July 1980 to 30 June 1981, Schools and Other Government Departments.

VARIOUS—Supply of kitchen equipment for period 1 July 1980 to 30 June 1981, Schools and Other Government Departments.

YALLOURN—Supply and delivery of workshop machines, part 1, Technical College.

TOM AUSTIN
Minister of Public Works

Public Works Department
Melbourne, 13 May 1980

The plans and specifications and an estimate of the cost of the proposed works and a statement showing the proposed expenditure of the money to be borrowed are open for inspection at the Municipal Offices, Lyttleton Terrace, Bendigo, during office hours.

6953

C. K. BEAMISH, Town Clerk

CITY OF BENDIGO

LOAN No. 112

Notice of Intention to Borrow the Sum of \$50 000 for Permanent Works and Undertakings

Notice is hereby given that the Council of the City of Bendigo proposes to borrow the principal sum of \$50 000 secured by a charge over the general rates of the municipality, such sum to be raised by the grant of a mortgage loan in accordance with the provisions of the *Local Government Act 1958*.

1. The maximum rate of interest that may be paid is 12.6 per cent per annum.

2. The purpose for which the loan is to be applied is:

Construction of Multi-Storey Car Park—
Hargreaves Street \$50 000
(Estimated total cost of proposed Multi-Storey Car Park—\$3 250 000)

3. The period of the loan shall be twenty (20) years.

4. The moneys borrowed shall be repayable by providing out of the Municipal Fund forty (40) half-yearly instalments of principal and interest of \$3449.52 on 24 June and 24 December during the currency of the loan. The first repayment shall be payable on 24 December 1980.

5. Such moneys shall be repayable at the National Bank of Australasia Limited, Pall Mall, Bendigo.

The plans and specifications and an estimate of the cost of the proposed works and a statement showing the proposed expenditure of the money to be borrowed are open for inspection at the Municipal Offices, Lyttleton Terrace, Bendigo, during office hours.

6954

C. K. BEAMISH, Town Clerk

CITY OF BENDIGO

LOAN No. 113

Notice of Intention to Borrow the Sum of \$50 000 for Permanent Works and Undertakings

Notice is hereby given that the Council of the City of Bendigo proposes to borrow the principal sum of \$50 000 secured by a charge over the general rates of the municipality, such sum to be raised by the grant of a mortgage loan in accordance with the provisions of the *Local Government Act 1958*.

1. The maximum rate of interest that may be paid is 12.6 per cent per annum.

2. The purpose for which the loan is to be applied is:

Construction of Multi-Storey Car Park—
Hargreaves Street \$50 000

3. The period of the loan shall be ten (10) years.

4. The moneys borrowed shall be repayable by providing out of the Municipal Fund nineteen (19) half-yearly instalments of principal and interest of \$3449.52 on 24 June and 24 December during the currency of the loan, with a final instalment of \$42 069.34 at the end of ten (10) years.

5. Such moneys shall be repayable at the Australia and New Zealand Savings Bank Limited, 48 Pall Mall, Bendigo.

The plans and specifications and an estimate of the cost of the proposed works and a statement showing the proposed expenditure of the money to be borrowed are open for inspection at the Municipal Offices, Lyttleton Terrace, Bendigo, during office hours.

6955

C. K. BEAMISH, Town Clerk

CITY OF BENDIGO

LOAN No. 114

Notice of Intention to Borrow the Sum of \$50 000 for Permanent Works and Undertakings

Notice is hereby given that the Council of the City of Bendigo proposes to borrow the principal sum of \$50 000 secured by a charge over the general rates of the municipality, such sum to be raised by the grant of a mortgage loan in accordance with the provisions of the *Local Government Act 1958*.

such sum to be raised by the grant of a mortgage loan in accordance with the provisions of the *Local Government Act 1958*.

1. The maximum rate of interest that may be paid is 12.6 per cent per annum.

2. The purpose for which the loan is to be applied is:

Construction of Multi-Storey Car Park—
Hargreaves Street \$50 000

3. The period of the loan shall be twenty (20) years.

4. The moneys borrowed shall be repayable by providing out of the Municipal Fund forty (40) half-yearly instalments of principal and interest of \$3449.52 on 1 January and 1 July during the currency of the loan. The first repayment shall be payable on 1 January 1981.

5. Such moneys shall be repayable to the Commissioners of the State Savings Bank of Victoria at the office of the said Commissioners, 233 Collins Street, Melbourne.

The plans and specifications and an estimate of the cost of the proposed works and a statement showing the proposed expenditure of the money to be borrowed are open for inspection at the Municipal Offices, Lyttleton Terrace, Bendigo, during office hours.

6956

C. K. BEAMISH, Town Clerk

CITY OF BENDIGO

LOAN No. 115

Notice of Intention to Borrow the Sum of \$50 000 for Permanent Works and Undertakings

Notice is hereby given that the Council of the City of Bendigo proposes to borrow the principal sum of \$50 000 secured by a charge over the general rates of the municipality, such sum to be raised by the grant of a mortgage loan in accordance with the provisions of the *Local Government Act 1958*.

1. The maximum rate of interest that may be paid is 12.5 per cent per annum.

2. The purpose for which the loan is to be applied is:

Construction of Multi-Storey Car Park—
Hargreaves Street \$50 000

3. The period of the loan shall be five (5) years.

4. The moneys borrowed shall be repayable by providing out of the Municipal Fund nine (9) half-yearly instalments of principal and interest of \$3428.33 on 24 June and 24 December during the currency of the loan, with a final instalment of \$49 382.88 at the end of the five-year period. The first repayment shall be payable on 24 December 1980.

5. Such moneys shall be repayable at the Commercial Banking Company of Sydney Limited, 12 View Street, Bendigo.

The plans and specifications and an estimate of the cost of the proposed works and a statement showing the proposed expenditure of the money to be borrowed are open for inspection at the Municipal Offices, Lyttleton Terrace, Bendigo, during office hours.

6957

C. K. BEAMISH, Town Clerk

CITY OF BENDIGO

LOAN No. 116

Notice of Intention to Borrow the Sum of \$100 000 for Permanent Works and Undertakings

Notice is hereby given that the Council of the City of Bendigo proposes to borrow the principal sum of \$100 000 secured by a charge over the general rates of the municipality, such sum to be raised by the grant of a mortgage loan in accordance with the provisions of the *Local Government Act 1958*.

1. The maximum rate of interest that may be paid is 12.6 per cent per annum.

2. The purpose for which the loan is to be applied is:

Construction of Multi-Storey Car Park—
Hargreaves Street \$100 000

3. The period of the loan shall be ten (10) years.

4. The moneys borrowed shall be repayable by providing out of the Municipal Fund nineteen (19) half-yearly instalments of principal and interest of \$6899.04 on

24 June and 24 December during the currency of the loan, with a final instalment of \$84 138.77. The first repayment shall be payable on 24 December 1980.

5. Such moneys shall be repayable at the Mercantile Mutual Life Insurance Company Limited, 117 Pitt Street, Sydney.

The plans and specifications and an estimate of the cost of the proposed works and a statement showing the proposed expenditure of the money to be borrowed are open for inspection at the Municipal Offices, Lyttleton Terrace, Bendigo, during office hours.

6958 C. K. BEAMISH, Town Clerk

CITY OF BENDIGO

LOAN NO. 117

Notice of Intention to Borrow the Sum of \$50 000 for Permanent Works and Undertakings

Notice is hereby given that the Council of the City of Bendigo proposes to borrow the principal sum of \$50 000 secured by a charge over the general rates of the municipality, such sum to be raised by the grant of a mortgage loan in accordance with the provisions of the *Local Government Act 1958*.

1. The maximum rate of interest that may be paid is 12.6 per cent per annum.

2. The purpose for which the loan is to be applied is:

Construction of Multi-Storey Car Park—
Hargreaves Street \$50 000

3. The period of the loan shall be ten (10) years.

4. The moneys borrowed shall be repayable by providing out of the Municipal Fund nineteen (19) half-yearly instalments of principal and interest of \$3449.52 on 24 June and 24 December during the currency of the loan, with a final instalment of \$42 069.34. The first repayment shall be payable on 24 December 1980.

5. Such moneys shall be repayable at the Australian Mutual Provident Society, 535 Bourke Street, Melbourne.

The plans and specifications and an estimate of the cost of the proposed works and a statement showing the proposed expenditure of the money to be borrowed are open for inspection at the Municipal Offices, Lyttleton Terrace, Bendigo, during office hours.

6959 C. K. BEAMISH, Town Clerk

CITY OF MELBOURNE

NAMING OF LANE

The Council of the City of Melbourne at its meeting held on 14 April 1980, approved the naming of the following lane—

Description and Location of Lane—The lane which is known as Corporation Lane No. 1739 is a cul-de-sac lane situated off the western side of Cobden Street, North Melbourne, approximately 20 000 metres north of Victoria Street.

Name—Cathay Lane.

F. H. ROGAN, Chief Executive Officer and Town Clerk
for and on behalf of the Council 7018

CITY OF MOORABBIN

NOTIFICATION OF CHANGE OF STREET NAMES

Notice is hereby given pursuant to the provision of section 535 of the *Local Government Act 1958* that the Council of the City of Moorabbin at a meeting held on 3 December 1979 resolved to make the following road name changes:

Old Names—Hopetoun Street, Fisher Street, Forster Street.

New Names—Hopetoun Court, Fisher Court, Forster Court.

Location—The streets are situated running in a northerly direction off Deakin Street, East Bentleigh.

JAMES W. WATERS, Town Clerk
Municipal Offices, 977 Nepean Highway, Moorabbin, 3189
6961

TOWN OF CAMPERDOWN

LOAN NO. 41

Notice of Intention to Borrow the Sum of \$15 000 for Permanent Works and Undertakings

Notice is hereby given that the Council of the Town of Camperdown proposes to borrow the sum of \$15 000 secured by a charge over the general rates of the municipality, such sum to be raised by the grant of a mortgage in accordance with the provisions of the *Local Government Act 1958*.

1. Maximum rate of interest that may be paid is 12 per centum per annum.

2. The purpose for which the loan is to be applied is part cost of nine tennis courts at the Public Park.

3. The period of the loan shall be ten years.

4. The moneys borrowed shall be repayable out of the municipal fund by half yearly instalments of \$1307.77 each, including principal and interest on 20 June and 20 December during the currency of the loan. The first instalment shall be payable on 20 December 1980.

5. Such moneys shall be repayable to the Commonwealth Savings Bank, Melbourne.

The plans and specifications and the estimates of the proposed works and a statement showing the proposed expenditure of the moneys proposed to be borrowed are open for inspection at the office of the council of the Town of Camperdown, 49 Ferguson Street, Camperdown. 6913

H. D. H. LEARMONTH, Town Clerk

SHIRE OF BELLARINE

LOAN NO. 101

Notice of Intention to Borrow the Sum of \$100 000 for Permanent Works and Undertakings

Notice is hereby given that the Council of the Shire of Bellarine proposes to borrow the principal sum of One Hundred Thousand Dollars (\$100 000) secured by a charge over the general rates of the municipality, such sum to be raised by the grant of a mortgage in accordance with the provisions of the *Local Government Act 1958*.

1. The maximum rate of interest that may be paid is 12 per centum per annum.

2. The purpose for which the loan is to be applied is:—

Road and Drainage Construction—
Part of Eggleston Street, Ocean Grove
(Part Cost) \$100 000.00

3. The period of the loan shall be ten years.

4. The moneys borrowed shall be repayable by providing out of the municipal fund twenty half-yearly instalments of interest, each amounting to \$6000.00 on 30 June and 31 December during the currency of the loan, and the provision annually from such fund of an amount of \$7586.80 and the application of such amount to the establishment and accumulation of a sinking fund which will be sufficient to repay in one sum, the principal amount of \$100 000 on 30 June 1990. The first instalment of interest shall be due and payable on 31 December 1980.

5. Such moneys shall be repayable to the Insurance Commissioner, Insurance Commissioner's Office, 480 Collins Street, Melbourne.

The plans and specifications and the estimate of the cost of the proposed works and a statement showing the proposed expenditure of the moneys to be borrowed, are open for inspection at the office of the Council of the Shire of Bellarine at Drysdale.

Dated 9 May 1980

6949

G. L. PEARCE, Shire Secretary

SHIRE OF BRIGHT

Notice is hereby given that the Council of the Shire of Bright, on 8 May 1980, appointed Sergeant Peter John Merrigan, No. 14694, as its Prosecuting Officer to take legal proceedings for and on behalf of the Council in connection with breaches and non-observance of the provisions of the *Local Government Act* or any other Act which the Council from time to time is empowered to enforce and any By-Laws, rules and regulations made under such Acts, in lieu of Sergeant Leon Gordon Smith, No. 11121, resigned.

6915

H. J. WILLIAMS, Shire Secretary

SHIRE OF KYNETON

LOAN No. 57

Notice of Intention to Borrow the Sum of \$20 000.00 for Permanent Works and Undertakings

Notice is hereby given that the Council of the Shire of Kyneton proposes to borrow the principal sum of Twenty Thousand Dollars (\$20 000.00) secured by a charge over the General Rates of the Municipality such sum to be raised by the Grant of a Mortgage in accordance with the provisions of the *Local Government Act 1958*.

1. The maximum rate of interest that may be paid is 12.5 per centum per annum.
2. The purpose for which the Loan is to be applied is the purchase of office furniture and equipment.
3. The terms of the Loan shall be five (5) years based on a Ten (10) year repayment schedule.
4. The money borrowed shall be repayable by providing out of the Municipal Fund—

Nine (9) instalments of \$1779.25 each including principal and interest on 1 July and 1 January during the currency of the Loan with a residual payment of \$14 720.97. The first instalment shall be payable on 1 January 1981.

5. Such moneys shall be repayable at the C.B.C. Savings Bank Ltd. Melbourne.

The plans and specifications and the estimate of the cost of the proposed works and a statement showing the proposed expenditure of the moneys to be borrowed are open for inspection at the Office of the Council, 29 Mollison Street, Kyneton during office hours.

Dated 9 May 1980

6960

S. G. PORTER, Shire Secretary

SHIRE OF PHILLIP ISLAND

LOAN No. 87

Notice of Intention to Borrow the Sum of \$100 000 for Permanent Works and Undertakings

Notice is hereby given that the Council of the Shire of Phillip Island proposes to borrow the principal sum of \$100 000 secured by a charge over the general rates of the municipality, such sum to be raised by the grant of a mortgage in accordance with the provisions of the *Local Government Act 1958*.

1. The maximum rate of interest that may be paid is 12 per cent per annum.
2. The purposes for which the loan is to be applied are as follows:—

	\$
Plant Purchase	30 000
Building—Plant Workshop	20 000
Toilet Block (Red Rocks)	16 000
Information Centre	10 000
Newhaven Recreation Reserve W/S, Drainage, Change rooms	24 000
	100 000

3. The period of the loan shall be 10 years.
4. The moneys borrowed shall be repayable by providing out of the municipal fund half-yearly instalments of approximately \$8718.46 each including principal and interest on 1 January and 1 July during the currency of the loan. The first instalment shall be payable on 1 January 1981.

5. Such moneys shall be repayable to the National Bank of Australasia Ltd., 31 Queen Street, Melbourne.

The plans and specifications and the estimate of the cost of the proposed works and a statement showing the proposed expenditure of the moneys to be borrowed are open for inspection at the office of the Council of the Shire of Phillip Island, State of Victoria, at Cowes 3922.

6916

STAN A. HARRIS, Municipal Clerk

Town and Country Planning Act 1961 (Twelfth Schedule)
SHIRE OF ROCHESTER (ROCHESTER TOWNSHIP)
PLANNING SCHEME

NOTICE THAT A PLANNING SCHEME HAS BEEN PREPARED AND IS AVAILABLE FOR INSPECTION

Amendment No. 13

Notice is hereby given that the Council of the Shire of Rochester in pursuance of its powers under the *Town and Country Planning Act 1961*, has prepared a Planning Scheme for the whole of the land described as:—

- (a) Part of Crown Allotments 4 and 5, Section 8A, Township of Rochester, Parish of Rochester West, County of Bendigo.
- (b) Crown Allotments 92, 93 and 94, Parish of Rochester West, County of Bendigo, and
- (c) Part of Crown Allotment 83, Parish of Rochester West, County of Bendigo,

for the purpose of altering and extending a public purposes reserve relating to land occupied by the State Electricity Commission, to delete a public purposes reserve relating to land previously proposed to be used by the Education Department, and to delete an incorrect reference on the planning scheme map to a subdivision.

A copy of the scheme has been deposited at the office of the Council of the Shire of Rochester, Mackay Street, Rochester and at the office of the Town and Country Planning Board, 235 Queen Street, Melbourne and will be open for inspection thereat during office hours by any person free of charge.

Any persons affected by the Planning Scheme are required to set forth in writing all objections they may have, addressed to the Shire Secretary, Shire of Rochester, Post Office Box 121, Rochester on or before 14 August 1980 and to state whether they wish to be heard in respect of their objections.

2 May 1980

6918

K. W. JACKEL, Shire Secretary

Town and Country Planning Act 1961 (Twelfth Schedule)
SHIRE OF SEYMOUR—SHIRE OF SEYMOUR PLANNING
SCHEME

NOTICE THAT A PLANNING SCHEME HAS BEEN PREPARED AND IS AVAILABLE FOR INSPECTION

Amendment No. 50, 1980

Notice is hereby given that the Shire of Seymour in pursuance of its powers under the *Town and Country Planning Act 1961* has prepared an amending Planning Scheme for the purpose of re-zoning lots 8, 9, 10, 11, 12, 13, 14, 16, 17, 18, 19, 20, 21, 22, 23 on plan of subdivision number 2149 Township and Parish of Seymour from "Residential" to "Public Purpose Reserve".

A copy of the Scheme has been deposited at the Shire Office, Seymour and at the office of the Town and Country Planning Board, 235 Queen Street, Melbourne and will be open for inspection during office hours by any person free of charge.

Any persons affected by the Planning Scheme are required to set forth in writing all objections they may have, addressed to the Shire Secretary, Shire Office, Seymour on or before 14 August 1980 and to state whether they wish to be heard in respect of their objections.

5 May 1980

6917

J. MATHEWS, Municipal Clerk

SHIRE OF STAWELL

ORDER DECLARING PUBLIC HIGHWAY

Pursuant to the provisions of Section 522 of the *Local Government Act 1958* the Council of the Shire of Stawell doth hereby Order that the lands next hereinafter described, which have been purchased by it, shall be public highways, viz.:

All that piece of land being parts of Crown Allotments 28A, 29A and 33 Section 6 Parish of Concongella as described in Certificate of Title, Volume 9354 Folio 748.

All that piece of land being part of Crown Allotment 10 Section 6 Parish of Concongella as described in Certificate of Title Volume 9350 Folio 873.

All that piece of land being part of Crown Allotment 31 Section 6 Parish of Concongella as described in Certificate of Title Volume 9447 Folio 655.

All that piece of land being part of Crown Allotment 41B Section 6 Parish of Concongella as described in Certificate of Title Volume 9354 Folio 470.

The common seal of the President, Councillors and Ratepayers of the Shire of Stawell was hereto affixed, 6 May 1980, in the presence of—

F. C. GRELLEE, President
M. A. READING, Councillor
V. C. NEILSEN, Secretary

6914

Water Act 1958 (Eighth Schedule)

KILMORE AND DISTRICT WATERWORKS TRUST

Notice is hereby given to the owners of properties within the Kilmore and Kilmore East, Wandong and Heathcote Junction Urban Districts that the Trust has laid water mains in:

George Street, Fitzroy Street, Albert Street, Mitchell Street, Andrew Street, Sydney Street, Melbourne Street, Chapel Street, Union Street, Gipps Street, Church Street, Bourke Street, Banoole Avenue, Foote Street, Victoria Parade, Hamilton Street, Powlett Street, White Street, Sutherland Street, Piper Street, Rutledge Street, Ryan's Road, Old Mill Road, Skehan Place, Limsden Street, Lamb Street, Allen Street, Green Street, Tootle Street, Monument Road, Club Parade, Link Avenue, Fairway Drive, Anderson Road, Clancy Road, Green Court, Koo-yong Court, Short Street, East Street, Northern Highway, William Street, Clarke Street, Mill Street, Lancefield Road, Parade Street, Brassy Road, Kilmore East Road, Hunt's Road, Duffy Street, Gavin Street, O'Grady's Road, Wandong Road, Wallan-Broadford Road, Harrington Street, Rail Street, Wandong Avenue, Dry Creek Crescent, Affleck Street, Wandong-Broadford Road, Mt. View Road, Dry Creek Road, Lyn Court, Range Avenue, Station Avenue, Mountain Road, View Road, Messmate Avenue, Eucalypt Grove, Baden Drive, Fern Court, Rail Street, Glenburnie Avenue, to serve the said Properties.

All owners of land situated with the Kilmore, Kilmore East, Wandong and Heathcote Junction Urban Districts and adjacent to the water mains are hereby requested on or before 29 May 1980 next to cause a proper pipe and stop cocks to be laid so as to supply water within such land from the main pipe.

G. G. SCOTT

7019 Kilmore and District Waterworks Trust

DROUIN SEWERAGE AUTHORITY

Pursuant to Section 119 (2) and Section III of the Sewerage Districts Act 1958, notice is hereby given by the Drouin Sewerage Authority of its intention to take land compulsorily (or by negotiation) outside the Drouin Sewerage District.

(A) The nature of the works in respect of which the land is proposed to be taken is to extend the Authority's treatment and disposal irrigation area.

(B) A plan or description of the proposed works is open for inspection at the offices of the Authority, 20 Princes Highway, Drouin, between 9 a.m. and 5 p.m. Mondays to Fridays.

(C) The quantity of land required for such works is all that area of land comprising Crown Allotments 74 and 145, Parish of Drouin West, and totalling 16.2 hectares or thereabouts.

6885

E. J. AUSTIN, F.I.W.A., Secretary

FRANKSTON SEWERAGE AUTHORITY

COMMENCEMENT OF WORKS

Notice is hereby given that the Authority intends to construct sewers in Golf Links Road to serve the St. Francis Xavier Primary School.

Details of the proposed works are available for inspection at the office of the Authority, Civic Centre Annexe, 34 Davey Street, Frankston, during office hours.

A. H. BUTLER, Secretary

Civic Centre Annexe, Frankston, 3199 6919

OCEAN GROVE SEWERAGE AUTHORITY

GENERAL NOTICE

The abovementioned Sewerage Authority, having made provision for carrying off the sewage from each and every property which or any part of which is within the sewerage area hereinafter described doth hereby declare that on and after 15 May 1980 each and every property which or any part of which is within the said sewerage area shall be deemed to be a seweraged property within the meaning of the Sewerage Districts Act 1958.

Sewerage Area No. 9

The boundaries of the sewerage area hereinbefore referred to are as indicated on a plan which is available for inspection at the Authority's Works Office, 77 The Parade, Ocean Grove.

By order of the said Sewerage Authority

6920 W. W. NAIRN, Chairman
G. L. PEARCE, Secretary

SIXTH SCHEDULE

QUEENSLIFFE SEWERAGE AUTHORITY

General Notice

The above-mentioned Sewerage Authority, having made provision for carrying off the sewage from each and every property which or any part of which is within the Sewerage Area hereinafter described, doth hereby declare that on and after 1 May 1980 each and every property which or any part of which is within the said Sewerage Area shall be deemed to be a seweraged property within the meaning of the Sewerage Districts Act 1958.

The said sewerage area known as Area No. 8 includes the following properties:—

Santa Monica Boulevard—Lots 1 to 16, 95, 96, 115 to 123.
Fellows Road—Lots 148 to 157.
Beachwood Drive—North Side, Lots 97-105.
Pico Avenue—All properties.
Hollywood Boulevard—Lots 158 to 165.
Hillcrest Drive—Lots 166 to 178.

7 May 1980

By order of the said Sewerage Authority

6921 F. C. MASON, Chairman
R. T. FORBES, Secretary

Notice is hereby given that the Life Ministry Centre has applied for a lease pursuant to section 134 of the Land Act 1958 for a term of 21 years in respect of Allotment 6 section 86 Township of Wonthaggi containing 13.7 hectares as a site for Amusement and Recreation. 6443

APPLICATION FOR DISPOSAL OF LAND PURSUANT TO AN ACT TO PROVIDE FOR THE ABOLITION OF STATE AID TO RELIGION

1. The Right Reverend Maxwell McNee Thomas of Wangaratta in the State of Victoria, Bishop of the Church of England Diocese of Wangaratta head or authorised representative of the Denomination known as The Church of England in the Diocese of Wangaratta in Victoria with the consent of The Church of England Trusts Corporation for the Diocese of Wangaratta of Wangaratta aforesaid which is entitled to be registered as the Trustee of the land described in the sub-joined Statement of Trusts hereby applies to the Governor of the State of Victoria for leave to dispose of the said land by means and for the purposes mentioned in the said Statement of Trusts and I hereby certify that the said land was promised or reserved as a site for the Church of England purposes on 31 January 1871.

2. That the Church of England Trusts Corporation for the Diocese of Wangaratta is entitled to be registered as the only Trustee of the said land.

3. There are no buildings erected upon the said land.

4. The only person entitled to minister or occupy same is the Incumbent for the Parish of Kilmore namely the Reverend G. H. Sexton of the Rectory, Union Street, Kilmore.

Dated 30 January 1980

Signed sealed and delivered by the said the Right Reverend Maxwell McNee Thomas in Victoria in the presence of W. H. GLEN.

M. M. THOMAS

The common seal of The Church of England Trusts Corporation for the Diocese of Wangaratta was hereunto affixed by authority of the Trustees—

(SEAL) M. M. THOMAS, Trustees
D. L. THAWLEY, Trustee
M. NELSON, Trustee

STATEMENT OF TRUSTS

Description of the Land—6070 square metres, Parish of Bylands, County of Bourke being Crown allotment 6b, section C. Commencing at a point bearing 0 deg. 00 min. 111.45 metres from the south-east corner of Crown allotment 6A, section C; bounded thence by that allotment bearing 270 deg. 00 min. 100.58 metres, 0 deg. 00 min. 60.35 metres and 90 deg. 00 min. 100.58 metres; and thence by a road bearing 180 deg. 00 min. 60.35 metres to the point of commencement.

Name of Trustee—The Church of England Trusts Corporation for the Diocese of Wangaratta of Wangaratta aforesaid.

Power of Disposition—Power to sell lease mortgage or exchange all or any part of such land subject to the approval of the Bishop of Wangaratta for the time being or during the absence of the Bishop from the Diocese or the vacancy of the See to the approval of the person for the time being administering the affairs thereof. The land until otherwise disposed of to be held for the purpose for which it was granted or reserved by the Crown.

Purposes to which Proceeds of Disposition are to be Applied—To such purposes of the Church of England as may be agreed upon by:

- (1) The Bishop or during his absence from his See or during the vacancy thereof by the person or persons for the time being administering the affairs of the Diocese.
- (2) The Trustee of the Church of England Trusts Corporation for the Diocese of Wangaratta.
- (3) The Minister entitled to occupy the aforesaid land.

Messrs. MAL RYAN, JACKSON & GLEN, of 9 High Street, Mansfield, solicitors for the applicant 6927

Notice is hereby given that the partnership existing between Brian John Fitch, Maria Lucia Fitch, Graham Arthur Curtis and Sonia Isabella Curtis carrying on business as a transport contractor under the style or firm name of Myuna Transport has been dissolved since 5 April 1980 and further take notice that the firm trading as Myuna Transport ceased from 6 April 1980.

SAM STIDSTON & CO., solicitors, Suite 3, Hast Court, 211 Main Street, Mornington, 3931 6922

Notice is hereby given that the partnership heretofore subsisting between Edward Thomas Scott, Phyllis Scott and John Ogle carrying on business as Glaziers at 8 Main Street, Lilydale under the style or firm of "S.O.S. Glass" has been dissolved as from 30 April 1980 as from which date all business will be conducted by "S.O.S. Glass Pty. Ltd." and which will operate from the same address.

GRAHAM V. McLEAN & CO., barristers and solicitors, of 57 Mt. Dandenong Road, Croydon 6923

PARTNERSHIP ACT 1958

I, Gary Bedggood-Henderson hereby notify that as from 30 April 1980 the partnership formerly subsisting between myself and Pauline Joan Bedggood-Henderson (Bidwell) which carried on the business of the Billabong Road House, Fernbank, has been terminated. As from 1 May 1980, I will carry on the above business for my own account.

6924

GARY BEDGGOOD-HENDERSON

Notice is hereby given that the partnership heretofore subsisting between Peter Braun and Andrew Stefan Fiedler carrying on the practice of General Medical Practitioners at 75A Fitzroy Street, St. Kilda under the style or firm name of "Jackson Street Medical Centre" has been dissolved as from 11 September 1979 so far as concerns the said Peter Braun who retired from the said firm.

MEERKIN & APEL, solicitors

6925

Notice is hereby given that the Partnership heretofore subsisting between Ross Charles Thomas of 1 Raheen Avenue, Wantirna in the State of Victoria and Peter Arnott of Heatherdale Road, Mitcham in the said State carrying on business as swimming pool contractors under the firm name of Anchor Swimming Pools has been dissolved by mutual consent as from 5 May 1980. All debts due to and owing by the said firm will be received and paid by Ross Charles Thomas who will continue to carry on the said business under the firm name of Anchor Swimming Pools.

Dated 5 May 1980

STEWART, McPHEE & GREVILLE, barristers and solicitors, of 199 Stud Road, Wantirna South, 3152 6926

PARTNERSHIP ACT 1958

Notice is hereby given that the Partnership heretofore subsisting between the undersigned Barrie John Gibson of Bay Road, Eagle Point, Kevin Bruce Hamilton of Granite Rock and Kenneth Leslie Waller of 52 Drevermann Street Bairnsdale carrying on business as Truck and Farm Equipment Sales and Service under the name of "Bairnsdale Inter Centre" has been dissolved from 30 June 1979 and the said Kevin Bruce Hamilton and Kenneth Leslie Waller shall continue the said business under the name of "Bairnsdale Inter Centre".

Dated 8 May 1980

B. J. GIBSON
K. B. HAMILTON
K. L. WALLER

6962

Notice is hereby given that the partnership heretofore subsisting between Angelo Cocca late of 102 Wilkens Street, Newport and Carmela Cocca of 102 Wilkens Street, Newport carrying on business as Hairdressers at 304 Melbourne Road, Newport under the style or name of A. & C. Cocca has been dissolved as from 5 December 1979 as a consequence of the said Angelo Cocca having died on that day.

NANNA F. WILCKENS & ROCHE, of 43 Ferguson Street, Williamstown, solicitors for the surviving partner Carmela Cocca 6997

The Mair Street General Practice Partnership of R. M. Brownfield, A. S. Murray, M. G. Aizen and K. T. Halliburton will cease on 10 May 1980.

Drs R. M. Brownfield, A. S. Murray and K. T. Halliburton will continue in Partnership as the Mair Street General Practice at 1011 Mair Street, Ballarat and at the Town Hall Clinic, Albert Street, Sebastopol. 7020

Take notice that the partnership between Pasquale Pesce and Paola Pesce and Angelo Pilla and Marisa Maria Pilla who carried on a General Engineering and Welding Works at 58 Paulson Road, Campbellfield is dissolved as at 26 April 1980 and that Pasquale Pesce and Paola Pesce shall continue trading at the above business premises as from that date.

PHILIP ADAMI of 159 Sydney Road, Coburg 7021

Companies Act 1961, Section 271

OAKVIEW PTY. LTD. (IN LIQUIDATION)

NOTICE OF MEETING OF CREDITORS

Notice is hereby given that a meeting of creditors of the above-named company will be held at Floor 9, 128 Exhibition Street, Melbourne on Friday 6 June 1980 at 11.00 a.m., the company having convened a meeting of its members for the same day.

Agenda

To lay before the meeting the liquidator's account showing how the winding up has been conducted and the property has been disposed of for the first twelve months, and to give any explanations of the account which may be required.

Melbourne, 30 April 1980

6928

A. D. CRAN, Liquidator

The Companies Act 1961—In the matter of LIGHT CITY PTY. LTD. (in Liquidation)—Pursuant to Section 272 of the Companies Act 1961

A Final meeting of members and creditors of the above-named company will be held in the offices of Maclean and Patterson, Chartered Accountants, 260 Auburn Road, Hawthorn 3122 on 27 June 1980 at 10.30 a.m., for the purpose of having laid before them, an account showing how the winding up has been conducted and the property of the company disposed of and hearing any explanation that may be given by the Liquidator.

Dated 12 May 1980

6929

THOMAS D. MACLEAN, Liquidator

The Companies Act 1961

N. PAINTS (W.A.) PTY. LTD. (IN MEMBERS' VOLUNTARY LIQUIDATION)

NOTICE CONVENING FINAL MEETING OF MEMBERS, PURSUANT TO SECTION 272

Notice is hereby given in pursuance of section 272 of the Companies Act 1961 that a Meeting of Members of the abovenamed Company will be held on 16 June 1980 at the Offices of Haines Toner & Co., 343 Little Collins Street, Melbourne at 3.00 p.m., for the purpose of having an account laid before them showing the manner in which the winding up has been conducted, and the property of the Company disposed of, and of hearing any explanations that may be given by the Liquidator.

Dated 5 May 1980

E. E. HAINES, Liquidator

Haines Toner & Co., chartered accountants, 343 Little Collins Street, Melbourne, Vic. 3000 6930

BANDAG COLD TREAD PROCESS (VIC.) PTY. LIMITED (IN VOLUNTARY LIQUIDATION)

NOTICE OF GENERAL MEETING

Notice is hereby given that a General Meeting of the members of the company in pursuance of section 272 of the Companies Act will be held at 31st Level, Australia Square Sydney at 10.15 a.m. on 23 June 1980 for the purpose of:—

1. Having an account showing how the winding up has been conducted and the property of the company disposed of laid before them.

2. Hearing any explanation given by the Liquidator.

3. Determining by resolution the manner in which the books and papers of the company shall be disposed of.

Dated at Sydney, 2 May 1980

6931

D. E. W. BLACKWELL, Liquidator

In the Supreme Court of Victoria—1980 No. Co. 11306—In the matter of the Companies Act 1961; and in the matter of E. A. EDWARDS PTY. LTD.—Advertisement of Petition

Notice is hereby given that a Petition for the winding up of the abovenamed Company by the Supreme Court was on 2 May 1980 presented by Louis Dreyfus and Co. Ltd., and that the said Petition is directed to be heard before the Court sitting at Practice Court, Law Courts, Melbourne at the hour of 10.30 a.m., on 12 June 1980 and any creditor or contributory of the said Company desiring to support or oppose the making of an order on the said Petition may appear at the time of hearing by himself or his Counsel for that purpose; and a copy of the Petition will be furnished to any creditor or contributory of the said Company requiring the same by the undersigned on payment of the regulated charge for the same.

The Petitioner's address is 505 St. Kilda Road, Melbourne.

The Petitioner's solicitors are Messrs Frederick W. Cox and Son, of 572 Lonsdale Street, Melbourne.

FREDERICK W. COX AND SON

NOTE—Any person who intends to appear on the hearing of the said Petition must serve on or send by post to the abovenamed Solicitors for the Petitioner, Messrs Frederick W. Cox and Son of 572 Lonsdale Street, Melbourne, notice in writing of his intention so to do. The notice must state the name and address of the person, if a firm, the name and address of the firm, and must be signed by the person or firm, or his or their solicitor (if any) and must be served, or, if posted, must be sent by post in sufficient time to reach the abovenamed not later than four o'clock in the afternoon of 11 June 1980. 6932

Companies Act 1961—In the matter of BRINAN PTY. LTD., Trading as "Brinan's Footwear" and "Murfi Boutique"—Notice Re Meeting of Creditors, Pursuant to Section 260

Notice is hereby given that a Meeting of Creditors of the abovenamed Company will be held at:—

144 Jolimont Road, East Melbourne

On: Tuesday, 27 May 1980

At: 10.30 a.m.

the Company having convened a Meeting of its Members for the same day for the purpose of considering a Special Resolution that the Company be wound up voluntarily.

Dated 7 May 1980

B. C. NANCARROW, Director

Bent & Cogle, public accountants, 144 Jolimont Road, East Melbourne 6933

COMPANIES ACT 1961

Notice is hereby given that pursuant to section 260 of the Companies Act a Meeting of Creditors of the under-mentioned companies will be held at the offices of Bent & Cogle, Public Accountants, 144 Jolimont Road, East Melbourne at the time stated on Thursday, 22 May 1980:

9.15 a.m. KINFLIN PTY. LTD.

9.30 a.m. KINSTROM INVESTMENTS PTY. LTD.

9.45 a.m. KINSTROM PROPERTIES PTY. LTD.

10.00 a.m. FORTY WINKS (SOUTH MELBOURNE) PTY. LTD.

10.15 a.m. YAMA KINA PTY. LTD.

11.00 a.m. FORTY WINKS PTY. LTD. (Receiver and Manager Appointed)

the Companies having convened a Meeting of their Members for the same day for the purpose of considering a Special Resolution that the Company be wound up voluntarily.

Dated 6 May 1980

BENT & COUGLE, public accountants, 144 Jolimont Road, East Melbourne, Vic. 3002 6934

Companies Act 1961

HABICRAFT PTY. LIMITED

LIQUIDATION OF COMPANY

Take notice that at a meeting of Habcraft Pty. Limited duly convened on 20 April 1980, it was resolved that the company be liquidated by way of a members voluntary liquidation and that Alwyn Leslie Beer of Alwyn L. Beer and Associates, 355 Victoria Street West Melbourne, be appointed liquidator for this purpose.

ALWYN L. BEER, Liquidator

Alwyn L. Beer and Associates, 355 Victoria Street, West Melbourne 6935

STEIN & ROGERS PROPRIETARY LIMITED (IN VOLUNTARY LIQUIDATION)

Notice is hereby given pursuant to Section 272 (2) of the Companies Act 1961 that a General Meeting of the members of the abovenamed Company will be held at 24 View Hill Road, North Balwyn, at 10.30 a.m. in the forenoon on 16 June 1980, for the purpose of having an

account laid before them showing the manner in which the winding up has been conducted and the assets of the Company disposed of and of hearing any explanations that may be given by the Liquidator.

6936 P. STEIN, Liquidator

THE BRAES PTY. LTD. (IN VOLUNTARY LIQUIDATION)

At an extraordinary general meeting of shareholders of The Braes Pty. Ltd. duly convened and held at "The Braes", Macarthur on 30 April 1980 at 12 noon the following special resolution was duly passed—

"That the Company be wound up voluntarily and that Mr John Bertrand McLarty of 56 Thompson Street, Hamilton be appointed liquidator."

Dated 2 May 1980

6937 J. B. McLARTY

Companies Act 1961—In the matter of RAMAY PROPRIETARY LIMITED (in Liquidation)—Notice Convening Final Meeting of Members and Creditors, Pursuant to Section 272

Notice is hereby given pursuant to Section 272 of the Companies Act 1961, that a General Meeting of Members and Creditors of the abovenamed Company will be held at the offices of B. K. Taylor & Co., 3rd Floor, 576 St. Kilda Road, Melbourne, on Wednesday 4 June 1980, at 11.00 a.m. for the purpose of having an account laid before them showing the manner in which the winding up has been conducted and the property of the Company disposed of and of hearing any explanations that may be given by the Liquidator.

Dated 5 May 1980

B. K. TAYLOR, Liquidator

B. K. Taylor & Co., accountants, 576 St. Kilda Road, Melbourne, Vic. 3004 6938

The Companies Act 1961

DOJAK PTY. LTD. (IN LIQUIDATION)

NOTICE CONVENING FINAL MEETING OF MEMBERS, PURSUANT TO SECTION 272

Notice is hereby given pursuant to section 272 of the Companies Act 1961 that a meeting of the members of the abovenamed company will be held on Friday, 13 June 1980 at 9.00 a.m. at the offices of Fordham, Williams & Co., Chartered Accountants, 521 Toorak Road, Toorak, for the purpose of having an account laid before them showing the manner in which the winding up has been conducted and the property of the company disposed of and hearing any explanations that may be given by the Liquidator.

Dated 8 May 1980

B. E. FORDHAM, Liquidator

Fordham, Williams & Co., 521 Toorak Road, Toorak, 3142. Telephone: 24 7511 6963

BROOKLYN CO-OPERATIVE HOUSING SOCIETY LIMITED (IN LIQUIDATION)

At a Special General Meeting of the abovenamed Society duly convened and held at Footscray R.S.L. Club, Geelong Road, Footscray on 6 May 1980 at 8.00 p.m. the sub-joined Special Resolution was duly passed:—

(a) That having successfully completed its objectives 5 years ahead of its expected term the Society be wound up voluntarily and that Mr Geoffrey Keith Davenport of 53 Wadham Parade, Mount Waverley be appointed Liquidator for the purpose of the winding-up.

(b) That the remuneration of the liquidator be fixed at \$375.00.

(c) That the Liquidator be empowered to compromise with debtors and/or creditors and/or contributories.

6964 W. J. NEILSON, Chairman of Meeting
G. K. DAVENPORT, Secretary

In the matter of the Co-operative Housing Societies Act 1958; and the Companies Act 1961; and in the matter of BROOKLYN CO-OPERATIVE HOUSING SOCIETY LIMITED (in Liquidation)—Notice to Creditors

Notice is hereby given that all persons having any claim against the above Society are required on or before 13 June 1980 to send their names and addresses and par-

ticulars of their debts or claims to Geoffrey Keith Davenport, the liquidator of the said Society, at his office and if so required by notice in writing from the said liquidator are personally, or by their Solicitors, to come in and prove their said claims at such time and place as shall be specified in such notice; or, in default thereof, they shall be excluded from the benefit of any distribution made before such debts or claims are so lodged or proved. Dated at Mount Waverley, 12 May 1980

G. K. DAVENPORT, Liquidator

53 Wadham Parade, Mount Waverley, 3149 6965

The Companies Act 1961

REMONY FARM PROPRIETARY LIMITED (MEMBERS' VOLUNTARY LIQUIDATION)

NOTICE OF FINAL MEETING OF MEMBERS, PURSUANT TO SECTION 272

Notice is hereby given that in pursuance of section 272 of the Companies Act 1961 that a meeting of the members of the above-named Company will be held on 19 June 1980 at 157 Moorabool Street, Geelong at 11.00 a.m. for the purpose of having an account laid before them showing the manner in which the winding up has been conducted and the property of the company disposed of and of hearing any explanation which may be given by the Liquidator.

Dated 9 May 1980

CEDRIC L. CARR, Liquidator

157 Moorabool Street, Geelong, 3220 6966

In the Supreme Court of Victoria—1980 No. Co. 11308
—In the matter of the Companies Act 1961; and in the matter of SEAFRESH PTY. LTD.

Notice is hereby given that a Petition for the winding up of the abovenamed Company by the Supreme Court was on 2 May 1980 presented by Oceanic Seafoods Pty. Ltd. and that the said Petition is directed to be heard before the Court sitting at the Practice Court Law Courts Melbourne on 12 June 1980 at the hour of 10.30 o'clock in the forenoon; and any creditors or contributory of the said Company desiring to support or oppose the making of an Order on the said Petition may appear at the time of the hearing by himself or his Counsel for that purpose; and a copy of the Petition will be furnished to any creditor or contributory of the said Company requiring the same by the undersigned on payment of the regulated charge for the same.

The Petitioner's Address is 830 Stanley Street, Woolongabba, Queensland.

The Petitioner's Solicitors are Messrs Graeme John & Michael Green of 235 Queen Street, Melbourne.

GRAEME JOHN & MICHAEL GREEN, solicitors for the petitioner

NOTE—Any person who intends to appear on the hearing of the said Petition must serve on or send by post to the abovenamed Solicitors notice in writing of his intention so to do. The notice must state the name and address of the person or, if a firm, the name and address of the firm and must be signed by the person or firm, or his or their Solicitor (if any) and must be served, or if posted, must be sent by post in sufficient time to reach the abovenamed not later than 4 o'clock in the afternoon on 11 June 1980. 6967

HAMPSHIRE HOUSE PTY. LTD.

MEMBERS' VOLUNTARY WINDING UP

At a general meeting of the above company, held at Melbourne on 5 May 1980, a special resolution was passed "that the company be wound up voluntarily and that Mr Francis Lucas be appointed Liquidator for the purposes of such winding up".

F. H. LUCAS, Liquidator

F. H. Lucas, 252 Swanston Street, Melbourne, 3000 6968

D. M. BOURKE PTY. LTD.
MEMBERS' VOLUNTARY WINDING UP

At a general meeting of the above company, held at Melbourne on 5 May 1980, a special resolution was passed "that the company be wound up voluntarily and that Mr Francis Lucas be appointed Liquidator for the purposes of such winding up".

F. H. LUCAS, Liquidator
F. H. Lucas, 252 Swanston Street, Melbourne, 3000
6969

The Companies Act 1961
MAGNETIC ELECTRIX PTY. LTD. (IN LIQUIDATION)
NOTICE CONVENING FINAL MEETING OF MEMBERS AND
CREDITORS, PURSUANT TO SECTION 272

Notice is hereby given pursuant to Section 272 of the Companies Act 1961 that a General Meeting of the members and Creditors of the abovenamed Company will be held at the offices of Messrs. Ferrier Hodgson Green & Co. Chartered Accountants, City Mutual Building 459 Collins Street, Melbourne on 18 June 1980 at 10 o'clock in the forenoon for the purpose of having an account laid before them showing the manner in which the winding up has been conducted and the property of the Company disposed of and of hearing any explanations that may be given by the Liquidator.

Dated 8 May 1980

A. G. HODGSON, Liquidator
Ferrier Hodgson Green & Co., chartered accountants,
459 Collins Street, Melbourne, 3000 6974

Companies Act 1961
GIBBONS FURNACES (AUSTRALIA) PROPRIETARY
LIMITED

Notice is hereby given that at an Extraordinary General Meeting of the Company held on 6 May 1980, the following resolution was approved:—

"That the Company be placed in Voluntary Liquidation and that Mr William P. Harrington of 54 Park Street, Sydney be appointed as Liquidator of the Company and the assets of the Company be distributed *in specie*."

Dated 6 May 1980

6975 W. P. HARRINGTON, Liquidator

Companies Act 1961
NORMAN J. HURLL & CO. (VICTORIA) PTY. LIMITED

Notice is hereby given that at an Extraordinary General Meeting of the Company held on 6 May 1980, the following resolution was approved:—

"That the Company be placed in Voluntary Liquidation and that Mr William P. Harrington of 54 Park Street, Sydney be appointed as Liquidator of the Company and that assets of the Company be distributed *in specie*."

Dated 6 May 1980

6976 W. P. HARRINGTON, Liquidator

Companies Act 1961 (as amended) Section 260 (1)—
In the matter of MUSTANG MANUFACTURING (Vic.) PTY.
LTD. of Factory A2, Lot 12, Burgess Road, North Bays-
water—Notice of Meeting of Creditors

Notice is hereby given that pursuant to Section 260 (1) of the Companies Act 1961 as amended, a meeting of creditors of Mustang Manufacturing (Vic.) Pty. Ltd. will be held at the Committee Road, Institute of Chartered Accountants, 140 Queen Street, Melbourne on 28 May 1980 at 10.30 a.m. the company having convened a meeting of its members for the same day for the purpose of considering a special resolution that the Company be wound up voluntarily.

Dated 12 May 1980

PANNELL KERR FORSTER, chartered accountants, 271
William Street, Melbourne, 3000. Telephone 67 7372 6977

A general meeting of Rural Meat Supply Pty. Ltd. (In Vol. Liq.) will be held at 9 Graham Road, Highett on 20 June 1980 at noon for the purpose of laying before it by the liquidator an account showing how the winding up has been conducted and the property of the company disposed of. 6978

Companies Act 1961
STAWELL INVESTMENTS PTY. LTD. (IN VOLUNTARY
LIQUIDATION)

Notice is hereby given in accordance with section 254 (b) that at an Extraordinary General Meeting of the members of Stawell Investments Pty. Ltd. held on 16 April 1980 it was resolved that the company be wound up voluntarily and that John Lachlan Charles McInnes be appointed as liquidator for the purposes of the winding up.
Dated 18 April 1980

J. L. C. McINNES, Liquidator
J. L. C. McInnes, chartered accountant, 12 Wellington
Parade, East Melbourne, 3002 6979

In the Supreme Court of Victoria—1980 No. Co. 19227—
In the matter of the Companies Act 1961; and in the
matter of SAFFRON NOMINEES PROPRIETARY LIMITED; and
in the matter of a Petition dated 24 April 1980

Notice is hereby given that a Petition for the winding up of the abovenamed company by the Supreme Court was on 30 April 1980 presented by Commercial Union Properties Pty. Ltd. and that the said Petition is directed to be heard before the Court sitting at the Law Courts, Lonsdale Street, Melbourne at the hour of 10.30 o'clock in the forenoon on 5 June 1980 and any Creditor or contributory of the said company desiring to support or oppose the making of an Order on the said Petition may appear at the time of the hearing by himself or his Counsel for that purpose; and a copy of the Petition will be furnished to any creditor or contributory of the said company requiring the same by the undersigned on payment of the regulated charge for the same.

The Petitioner's address is 422 Collins Street, Melbourne, Victoria.

The Petitioner's solicitors are Messrs Ellison Hewison & Whitehead of 379 Collins Street, Melbourne.

NOTE—Any person who intends to appear on the hearing of the said Petition must serve or send by post to the abovenamed solicitors, notice in writing of his intention so to do. The Notice must state the name and address of the person, or, if a firm, the name and address of the firm must be signed by the person or firm or his or their solicitor (if any) and must be served, or if posted must be sent by post, in sufficient time to reach the abovenamed not later than four o'clock in the afternoon of Wednesday 4 June 1980, the day before the day appointed for hearing of the Petition.

ELLISON, HEWISON & WHITEHEAD, solicitors for the
petitioner 6980

Companies Act 1961
I.N.L. INVESTMENTS PTY. LTD. (IN VOLUNTARY
LIQUIDATION)

Notice is hereby given in accordance with section 254 (b) that at an Extraordinary General Meeting of the members of I.N.L. Investments Pty. Ltd. held on 16 April 1980 it was resolved that the company be wound up voluntarily and that John Lachlan Charles McInnes be appointed as liquidator for the purposes of the winding up.
Dated 18 April 1980

J. L. C. McINNES, Liquidator
J. L. C. McInnes, chartered accountant, 12 Wellington
Parade, East Melbourne, 3002 6981

Companies Act 1961
L.B. INVESTMENTS PTY. LTD. (IN VOLUNTARY
LIQUIDATION)

Notice is hereby given in accordance with section 254 (b) that at an Extraordinary General Meeting of the members of L.B. Investments Pty. Ltd. held on 16 April

1980 it was resolved that the company be wound up voluntarily and that John Lachlan Charles McInnes be appointed as liquidator for the purposes of the winding up.
Dated 18 April 1980

J. L. C. McINNES, Liquidator

J. L. C. McInnes, chartered accountant, 12 Wellington Parade, East Melbourne, 3002 6982

**Companies Act 1961
WILKIRK PTY. LTD.**

Notice is hereby given that by a Special Resolution passed at a Meeting of Shareholders of Wilkirk Pty. Ltd. held on 8 May 1980, it was resolved that the Company be wound up voluntarily.

Notice is also given that creditors having any claim against the Company should furnish particulars of that claim within 21 days of this date, otherwise distribution of the assets will take place without regard to such claims.

Dated 9 May 1980

R. C. PENNELL AND G. C. BEESTON, Joint and Several Liquidators

Hughes, Fincher & Rodda, chartered accountants, 44 Market Street, Melbourne, Vic. 3000 6983

**Companies Act 1961
BEEFJAY PTY. LTD.**

Notice is hereby given that by a Special Resolution passed at a Meeting of Shareholders of Beefjay Pty. Ltd. held on 8 May 1980, it was resolved that the Company be wound up voluntarily.

Notice is also given that creditors having any claim against the Company should furnish particulars of that claim within 21 days of this date, otherwise distribution of the assets will take place without regard to such claims.

Dated 9 May 1980

R. C. PENNELL AND G. C. BEESTON, Joint and Several Liquidators

Hughes, Fincher & Rodda, chartered accountants, 44 Market Street, Melbourne, Vic. 3000 6984

**Companies Act 1961, Section 272
YASPAP PTY. LTD. (IN LIQUIDATION)
ELDDAP PTY. LTD. (IN LIQUIDATION)**

NOTICE OF FINAL MEETINGS

Notice is hereby given that the final meetings of the members of the abovenamed companies will be held at my offices on 6 June 1980 commencing at 3.00 p.m., for the purpose of laying before the meetings an account showing how the windings up have been conducted and the property of the companies disposed of and giving any explanation thereof.

Dated 29 April 1980

G. W. LONG, Liquidator

V. R. Dye & Co., chartered accountants, 536 Whitehorse Road, Mitcham, 3132 6985

GREITER INTERNATIONAL PTY. LTD.

At a Meeting of the Members of the above Company held on 5 May 1980, the following Special Resolution was duly passed:—

"Resolved that the Company be wound up voluntarily and that Rodney Anderson, Public Accountant, of Level 18, 390 St. Kilda Road, Melbourne be hereby appointed Liquidator for the purpose of winding up the Company."

Dated 5 May 1980

R. ANDERSON, Liquidator

Lasky, Hack & Anderson, Level 18, 390 St. Kilda Road, Melbourne, Vic. 3004 6986

HENLEY PHARMACEUTICALS PTY. LTD.

At a Meeting of the Members of the above Company held on 5 May 1980, the following Special Resolution was duly passed:—

"Resolved that the Company be wound up voluntarily and that Rodney Anderson, Public Accountant, of Level 18, 390 St. Kilda Road, Melbourne be hereby appointed Liquidator for the purpose of winding up the Company."

Dated 5 May 1980

R. ANDERSON, Liquidator

Lasky, Hack & Anderson, Level 18, 390 St. Kilda Road, Melbourne, Vic., 3004 6987

GIBBONS FURNACES (AUSTRALIA) PROPRIETARY LIMITED (IN VOLUNTARY LIQUIDATION)

NOTICE CONVENING FINAL MEETING, PURSUANT TO SECTION 272 OF THE COMPANIES ACT 1961

Pursuant to Section 272 of the Companies Act 1961 a general meeting of members of the above mentioned company will be held on the 10th Floor, 350 Latrobe Street, Melbourne, Victoria on Thursday 12 June 1980 at 2.15 p.m. for the purpose of having an account laid before them showing the manner in which the winding up has been conducted and the property disposed of and of hearing any explanation that may be given by the liquidator.

Dated 8 May 1980

6988

W. P. HARRINGTON, Liquidator

NORMAN J. HURLL & CO. (VICTORIA) PTY. LIMITED (IN VOLUNTARY LIQUIDATION)

NOTICE CONVENING FINAL MEETING, PURSUANT TO SECTION 272 OF THE COMPANIES ACT 1961

Pursuant to Section 272 of the Companies Act 1961 a general meeting of members of the above mentioned company will be held on the 10th Floor, 350 Latrobe Street, Melbourne, Victoria on Thursday 12 June 1980 at 2.00 p.m. for the purpose of having an account laid before them showing the manner in which the winding up has been conducted and the property disposed of and of hearing any explanation that may be given by the liquidator.

Dated 8 May 1980

6989

W. P. HARRINGTON, Liquidator

SCREENCLOTHS PROPRIETARY LIMITED (IN VOLUNTARY LIQUIDATION)

NOTICE CONVENING FINAL MEETING, PURSUANT TO SECTION 272 OF THE COMPANIES ACT 1961

Pursuant to Section 272 of the Companies Act 1961 a general meeting of members of the above mentioned company will be held at 522 Clayton Road, Clayton, Victoria on Thursday, 12 June 1980 at 9.00 a.m. for the purpose of having an account laid before them showing the manner in which the winding up has been conducted and the property disposed of and of hearing any explanation that may be given by the liquidator.

Dated 8 May 1980

6990

W. P. HARRINGTON, Liquidator

CANONE PROPRIETARY LIMITED (IN VOLUNTARY LIQUIDATION)

NOTICE CONVENING FINAL MEETING, PURSUANT TO SECTION 272 OF THE COMPANIES ACT 1961

Pursuant to Section 272 of the Companies Act 1961 a General Meeting of members of the above-mentioned company will be held at the office of the liquidator, 13th floor, 257 Collins Street, Melbourne on Monday 16 June 1980 at 11.00 a.m. for the purpose of having an account laid before them showing the manner in which the winding up has been conducted and the property of the company disposed of, and of hearing any explanations that may be given by the liquidator.

Dated 7 May 1980

6991

ERIC E. FOKES, Liquidator

W. & J. BARR (PRINTERS) PTY. LTD.**NOTICE OF INTENTION TO DECLARE DIVIDEND**

Notice is hereby given that as Liquidator of the above company I have fixed 2 June 1980 on or before which the Creditors of the company are to prove their debts or claims under Sub-Section (1) of Section 291 of the Companies Act 1961 against the company and notice is hereby given that it is my intention thereafter to declare a first and final dividend.

6992

J. E. WIGGIN, Liquidator

Companies Act 1961, Section 260**COATRIAL PTY. LTD.**

(Formerly COATING & INDUSTRIAL SERVICES (1976) PTY. LTD.)

Notice is hereby given that at a meeting of the above company a resolution for voluntary winding up is to be proposed and a meeting of its creditors will be held at the offices of John C. Barnes & Co., 470 Bourke Street, Melbourne, at 11 a.m. on the same day Wednesday, 28 May 1980.

D. J. BATTEN, Director

John C. Barnes & Co., 470 Bourke Street, Melbourne, 3000. Telephone: 67 8679 6993

Companies Act 1961, Section 260**CHECKPOINT TYRE SERVICE PTY. LTD.****NOTICE OF MEETING OF CREDITORS**

Notice is hereby given that a meeting of Creditors of Checkpoint Tyre Service Pty. Ltd. will be held at the Meeting Room, the office of Hosking, Dyer and Co., 1st Floor, 153 Park Street, South Melbourne on Wednesday 14 May 1980 at 10.00 a.m., the Company having convened a meeting of its members for the same day for the purpose of considering a Resolution that the Company be wound up voluntarily.

Dated 5 May 1980.

S. DIMITRIOU, Director

Hosking, Dyer and Co., public accountants, 1st Floor, 153 Park Street, South Melbourne, 3205. Telephone: 690 6466 6994

Companies Act 1961, Section 254 (2) (b)**PORCELLUS PROPRIETARY LIMITED**

Notice is hereby given that at an Extraordinary General Meeting of the members of the abovenamed Company held on 7 May 1980, it was resolved that the Company be wound up voluntarily and at a Meeting of Creditors held on the same day, it was resolved that for such purposes Harold George Alexander, Chartered Accountant of Messrs Hungerford Hancock & Offner, 29th Floor, 367 Collins Street, Melbourne, be appointed Liquidator.

Notice is also given that after 21 days from this date I shall proceed to distribute the assets. All Creditors having any claims against the Company should furnish particulars of same by that date, otherwise I shall proceed to distribute the assets without regard to their claim.

Dated 8 May 1980

HAROLD GEORGE ALEXANDER, Liquidator

Messrs Hungerford Hancock & Offner, chartered accountants, 29th Floor, 367 Collins Street, Melbourne, Vic. 3000 6995

The Companies Act 1961**STUDIO DYBKA PTY. LTD. (IN LIQUIDATION)****NOTICE CONVENING FINAL MEETING OF MEMBERS AND CREDITORS, PURSUANT TO SECTION 272**

Notice is hereby given pursuant to section 272 of the Companies Act 1961 that a General Meeting of the members and creditors of the abovenamed Company will be held at the offices of Ferrier Hodgson Green & Co., Chartered Accountants, 24th Floor, 459 Collins Street, Melbourne on 16 June 1980 at 10.00 o'clock in the forenoon and for the purpose of having an account laid before

them showing the manner in which the winding up has been conducted and the property of the Company disposed of and of hearing any explanations that may be given by the Liquidator.

Dated 12 May 1980

A. G. HODGSON, Liquidator

Ferrier Hodgson Green & Co., chartered accountants, 459 Collins Street, Melbourne, 3000 7022

Companies Act 1961—In the matter of CHAMPAGNE RECORDS PTY. LTD. (in Liquidation)

Notice is hereby given that pursuant to section 272 of the Companies Act a final meeting of members and creditors of the abovenamed company will be held at the office of Maclean and Patterson, Chartered Accountants, 260 Auburn Road, Hawthorn on 27 June 1980 at 10.00 a.m. for the purpose of having laid before them an account showing the manner in which the winding up has been conducted and the property of the company disposed of and hearing any explanation that may be given by the Liquidator.

Dated 12 May 1980.

7023

THOMAS D. MACLEAN, Liquidator

WANGARATTA CO-OPERATIVE HOUSING SOCIETY No. 3 LTD. (IN LIQUIDATION)

Take notice that the affairs of the above-named Society are now fully wound up and that in pursuance of section 272 (1) of the Companies Act 1961 and of the Co-operative Housing Societies Act 1958, a General Meeting of the Society will be held at 14 Chisholm Street, Wangaratta at 5.30 p.m. on Monday, 23 June 1980 for the purposes of—

- (i) laying before it an account showing how the winding up has been conducted and the property of the Society disposed of and giving any explanations thereof; and
- (ii) passing a resolution that the books and papers of the said Society and of the Liquidator relevant to the affairs of the Society be destroyed after a period of twelve months from the date of the meeting.

Dated 12 May 1980

7024

R. C. MACKENZIE, Liquidator

In the matter of the Companies Act; and in the matter of HAAPI ENTERPRISES PROPRIETARY LIMITED

Notice is hereby given that at an Extraordinary General Meeting of the abovenamed Company duly convened and held at 15 Moule Avenue, Brighton at eight o'clock in the afternoon on 12 May 1980 the following special resolutions were duly passed:—

That the Company be wound up voluntarily and that Peter Wills Cooke of 3 Hall Court, Dandenong be appointed Liquidator for the purposes of such winding up.

That notwithstanding the appointment of the Liquidator of the Company, and having regard to the approval in writing of the Liquidator tabled at this Meeting, the Directors of the Company be hereby authorised to continue to exercise their powers as Directors for the purpose of carrying on the Company's business so far as may be required for the beneficial winding up thereof.

Dated 13 May 1980

7025

A. I. BALLANTINE, Chairman

In the matter of the Companies Act 1961; and in the matter of PRESTON TRADING Co. PTY. LTD. (in Liquidation)—NOTICE OF FINAL MEETING OF MEMBERS, PURSUANT TO SECTION 272

Notice is hereby given in pursuance of section 272 of the Companies Act 1961 that a General Meeting of the members of the Company will be held at the office of Hinsley & Watmuff, 4th Floor, 691 Burke Road, Camberwell on 17 June 1980 at 9.30 o'clock in the forenoon for the purpose of having an account laid before it showing

the manner in which the winding up has been conducted and the property of the Company disposed of, and hearing any explanation that may be given by the liquidator.

Dated 12 May 1980

P. C. WATMUFF, Liquidator

Hinsley & Watmuff, chartered accountants, 4th Floor,
691 Burke Road, Camberwell 7026

Companies Act 1961—In the matter of S. WILLIAM JOHNSON PTY. LTD. (C.34771); STUART JOHNSON PTY. LTD. (C.28563-A); F. C. RITCHIE PTY. LTD. (C.28580-A) (in Voluntary Liquidation)

Notice is hereby given that at Extraordinary General Meetings of the members of the abovenamed Companies held on 12 May 1980 it was resolved that each of the Companies be wound up voluntarily and that Eric Stanwell Field and Peter Charles Phillips of W. Marshall & Associates of Suite 2, 162 Albert Road, South Melbourne—Chartered Accountants be appointed Liquidators.

Notice is also given that after twenty-one days from this date we shall proceed to distribute the assets of each Company. All creditors having any claims against any of the Companies should furnish particulars of same by that date otherwise we shall proceed to distribute the assets without regard to their claim.

Dated 12 May 1980

7027 E. S. FIELD AND P. C. PHILLIPS, Liquidators

In the Supreme Court of Victoria—1980 No. Co. G11295 In the matter of the Companies Act 1961; and in the matter of SCRITRAL PTY. LTD.; and in the matter of a Petition dated 29 April 1980—Advertisement of Petition

Notice is hereby given that a Petition for the winding up of the abovenamed Company by the Supreme Court was on 29 April 1980 presented by Norman Patrick Tyrrell. And that the said Petition is directed to be heard before the Court sitting at the Law Courts Lonsdale Street, Melbourne at the hour of 10.30 o'clock in the forenoon on 5 June 1980 and any Creditor or contributory of the said Company desiring to support or oppose the making of an order on the said Petition may appear at the time of hearing by himself or his counsel for that purpose; and a copy of the Petition will be furnished to any creditor or contributory of the said company requiring the same by the undersigned on payment of the regulated charge for the same.

The Petitioner's address is 300 Burwood Road, Hawthorn, Victoria.

The Petitioner's Solicitors are Messrs Kaye, Levy & Co., of 247 Hawthorn Road, Caulfield.

KAYE, LEVY & CO., Solicitors for the Petitioner

NOTE—Any person who intends to appear on the hearing of the said Petition must serve on or send by post to the abovenamed Solicitors notice in writing of his intention to do so. The notice must state the name and address of the firm, and must be signed by the person or firm or their Solicitor (if any) and must be served, or, if posted must be sent by post in sufficient time to reach the abovenamed not later than four o'clock in the afternoon on 4 June 1980 7028

Companies Act, Section 254 (2) (b)
PARBURY INDUSTRIAL EQUIPMENT PROPRIETARY LIMITED

Notice is hereby given that at an Extraordinary General Meeting of the members of the abovenamed company held on 6 May 1980 it was resolved that the company be wound up voluntarily and that Eric Edwin Haines of 343 Little Collins Street, Melbourne, be appointed Liquidator.

Notice is also given that after 21 days from this date I shall proceed to distribute the assets. All creditors having any claims against the company should furnish particulars of same by that date, otherwise I shall proceed to distribute the assets without regard to their claim.

Dated 12 May 1980

7029 E. E. HAINES, Liquidator

No. 34—20690/80—4

Companies Act 1961

LIBERTY INDUSTRIAL TRUCKS PTY. LTD.
INDUSTRIAL TRACTOR & EARTH MOVING EQUIPMENT PTY. LTD.
CONTINENTAL & GENERAL DISTRIBUTORS PTY. LTD.
CANADIAN MOTOR TRADING CO. PTY. LTD.
CANADA CYCLE & MOTOR CO. (VIC.) PTY. LTD.
CANADA CYCLE & MOTOR CO. (SALES) PTY. LTD.
AUTOGEN HIRING PTY. LTD.
AUSTIN DISTRIBUTORS PTY. LTD.
AUSDIS PANEL AND ENGINEERING PTY. LTD.
AUSDIS SPARES PTY. LTD.
AUSDIS FINANCE PTY. LTD.
NORTHERN ENGINEERING PTY. LTD.

Notice is hereby given that a meeting of members of the above companies will be held at the office of Nelson Wheeler, Chartered Accountants, 430 William Street, Melbourne, on 6 June 1980 commencing at 10.00 a.m. for the purpose of considering a resolution that the company be wound up voluntarily.

7030

J. GUSS, Director

The Companies Act 1961, Section 291 and Regulation 54
—In the matter of ELIMAX NOMINEES PTY. LTD. (in Liquidation)

Take notice that as Liquidator of the abovenamed Company I have fixed Wednesday, 28 May 1980 as the day on or before which creditors of the company are to prove their debts or claims and to establish any title they may have to priority under section 292 or be excluded from the benefit of a first and final distribution made before such debts are proved or as the case may be from objecting to such distribution.

Dated 14 May 1980

R. E. RAMSAY, Liquidator

Wallace, McMullin & Smail, chartered accountants, 499
St. Kilda Road, Melbourne, 3004 7042

Companies Act 1961, Section 254 (2) (b)
CLENDON INVESTMENT PROPRIETARY LIMITED

Notice is hereby given that at an Extraordinary General Meeting of the members of the abovenamed Company held on 9 May 1980, it was resolved that the Company be wound up voluntarily and at a Meeting of Creditors held on the same day, it was resolved that for such purposes Harold George Alexander, Chartered Accountant of Messrs Hungerford Hancock & Offner, 29th Floor, 367 Collins Street, Melbourne, be appointed Liquidator.

Notice is also given that after 21 days from this date I shall proceed to distribute the assets. All Creditors having any claims against the Company should furnish particulars of same by that date, otherwise I shall proceed to distribute the assets without regard to their claim.

Dated 12 May 1980

7043 HAROLD GEORGE ALEXANDER, Liquidator

In the matter of B.T.M. AGENCIES PTY. LIMITED; MEPHAN FERGUSON PTY. LIMITED; BUNDY TUBING COMPANY (VICTORIA) PTY. LIMITED; and in the matter of the Companies Act 1961

Take notice that each of the abovenamed companies on 1 May 1980 duly resolved by special resolution that it wound up voluntarily, and resolved by ordinary resolution that Ronald George Davies be appointed liquidator for the purposes of the winding up.

7 May 1980

7045 J. G. GOSSE, Director

Companies Act 1961, Section 254 (2) (b)
AVENEL INVESTMENT PROPRIETARY LIMITED

Notice is hereby given that at an Extraordinary General Meeting of the members of the abovenamed Company held on 9 May 1980, it was resolved that the Company be wound up voluntarily and at a Meeting of Creditors held on the same day, it was resolved that for such purposes Harold George Alexander, Chartered Accountant of Messrs Hungerford Hancock & Offner, 29th Floor, 367 Collins Street, Melbourne, be appointed Liquidator.

Notice is also given that after 21 days from this date I shall proceed to distribute the assets. All Creditors having any claims against the Company should furnish particulars of same by that date, otherwise I shall proceed to distribute the assets without regard to their claim.

Dated 12 May 1980

7044 HAROLD GEORGE ALEXANDER, Liquidator

In the Supreme Court of Victoria—In the matter of the *Companies Act 1961*; and in the matter of KATTONI NOMINEES PROPRIETARY LIMITED

Notice is hereby given that a petition for the winding up of the abovenamed Company by the Supreme Court was on 8 May 1980 presented by Kevin Patrick Brady, Deputy Commissioner of Taxation of the Commonwealth of Australia and that the said petition is directed to be heard before the Court sitting at the Fifteenth Court, Law Courts, Lonsdale Street, Melbourne, at the hour of 10.30 o'clock in the forenoon on 29 May 1980 and any creditor or contributory of the said company desiring to support or oppose the making of an order on the said petition may appear at the time of hearing by himself or his Counsel for the purpose; and a copy of the said petition will be furnished to any creditor or contributory of the said company requiring the same by the undersigned on payment of the regulated charge for the same.

The Petitioner's official address is 350 Collins Street, Melbourne.

The Petitioner's Solicitor is B. J. O'Donovan, Crown Solicitor for the Commonwealth of 99 Queen Street, Melbourne.

B. J. O'DONOVAN

NOTE—Any person who intends to appear on the hearing of the said petition must serve on or send by post to the abovenamed B. J. O'Donovan, notice in writing of his intention so to do. The notice must state the name and address of the person, or, if a firm, the name and address of the firm, and must be signed by the person or firm, or his, or their solicitor (if any), and must be served, or, if posted, must be sent by post in sufficient time to reach the abovenamed not later than 4 o'clock in the afternoon of 28 May 1980. 7046

In the Supreme Court of Victoria—In the matter of the *Companies Act 1961*; and in the matter of WILLATON BROS. PTY. LTD.

Notice is hereby given that a petition for the winding up of the abovenamed Company by the Supreme Court was on 8 May 1980 presented by Kevin Patrick Brady, Deputy Commissioner of Taxation of the Commonwealth of Australia and that the said petition is directed to be heard before the Court sitting at the Fifteenth Court, Law Courts, Lonsdale Street, Melbourne, at the hour of 10.30 o'clock in the forenoon on 29 May 1980 and any creditor or contributory of the said company desiring to support or oppose the making of an order on the said petition may appear at the time of hearing by himself or his Counsel for the purpose; and a copy of the said petition will be furnished to any creditor or contributory of the said company requiring the same by the undersigned on payment of the regulated charge for the same.

The Petitioner's official address is 350 Collins Street, Melbourne.

The Petitioner's Solicitor is B. J. O'Donovan, Crown Solicitor for the Commonwealth of 99 Queen Street, Melbourne.

B. J. O'DONOVAN

NOTE—Any person who intends to appear on the hearing of the said petition must serve on or send by post to the abovenamed B. J. O'Donovan, notice in writing of his intention so to do. The notice must state the name and address of the person, or, if a firm, the name

and address of the firm, and must be signed by the person or firm, or his, or their solicitor (if any), and must be served, or, if posted, must be sent by post in sufficient time to reach the abovenamed not later than 4 o'clock in the afternoon of 28 May 1980. 7047

In the Supreme Court of Victoria—In the matter of the *Companies Act 1961*; and in the matter of NORTH EAST TANNERY PTY. LTD.

Notice is hereby given that a petition for the winding up of the abovenamed Company by the Supreme Court was on 8 May 1980 presented by Kevin Patrick Brady, Deputy Commissioner of Taxation of the Commonwealth of Australia and that the said petition is directed to be heard before the Court sitting at the Fifteenth Court, Law Courts, Lonsdale Street, Melbourne, at the hour of 10.30 o'clock in the forenoon on 29 May 1980 and any creditor or contributory of the said company desiring to support or oppose the making of an order on the said petition may appear at the time of hearing by himself or his Counsel for the purpose; and a copy of the said petition will be furnished to any creditor or contributory of the said company requiring the same by the undersigned on payment of the regulated charge for the same.

The Petitioner's official address is 350 Collins Street, Melbourne.

The Petitioner's Solicitor is B. J. O'Donovan, Crown Solicitor for the Commonwealth of 99 Queen Street, Melbourne.

B. J. O'DONOVAN

NOTE—Any person who intends to appear on the hearing of the said petition must serve on or send by post to the abovenamed B. J. O'Donovan, notice in writing of his intention so to do. The notice must state the name and address of the person, or, if a firm, the name and address of the firm, and must be signed by the person or firm, or his, or their solicitor (if any), and must be served, or, if posted, must be sent by post in sufficient time to reach the abovenamed not later than 4 o'clock in the afternoon of 28 May 1980. 7048

In the Supreme Court of Victoria—In the matter of the *Companies Act 1961*; and in the matter of HILLSTOCK PROPRIETARY LIMITED

Notice is hereby given that a petition for the winding up of the abovenamed Company by the Supreme Court was on 8 May 1980 presented by Kevin Patrick Brady, Deputy Commissioner of Taxation of the Commonwealth of Australia and that the said petition is directed to be heard before the Court sitting at the Fifteenth Court, Law Courts, Lonsdale Street, Melbourne, at the hour of 10.30 o'clock in the forenoon on 29 May 1980 and any creditor or contributory of the said company desiring to support or oppose the making of an order on the said petition may appear at the time of hearing by himself or his Counsel for the purpose; and a copy of the said petition will be furnished to any creditor or contributory of the said company requiring the same by the undersigned on payment of the regulated charge for the same.

The Petitioner's official address is 350 Collins Street, Melbourne.

The Petitioner's Solicitor is B. J. O'Donovan, Crown Solicitor for the Commonwealth of 99 Queen Street, Melbourne.

B. J. O'DONOVAN

NOTE—Any person who intends to appear on the hearing of the said petition must serve on or send by post to the abovenamed B. J. O'Donovan, notice in writing of his intention so to do. The notice must state the name and address of the person, or, if a firm, the name and address of the firm, and must be signed by the person or firm, or his, or their solicitor (if any), and must be served, or, if posted, must be sent by post in sufficient time to reach the abovenamed not later than 4 o'clock in the afternoon of 28 May 1980. 7049

Unclaimed Moneys Act 1962

Register of Unclaimed Moneys held by the—

Name of Owner on Books and Last Known Address	Total Amount Due to Owner	Description of Unclaimed Money	Date when Amount first became Payable
S			
GROUP SHARE REGISTRY PTY. LIMITED			
Adams, Harold Sidney, 5 Pindari Rd, Dover Heights, N.S.W.	193.30	Dividend	3:11.78
Amaral, Robert Jack and Gladys Florence (Mrs), P.O. Box 682, Tamworth, N.S.W.	77.73	"	"
Anderson, Laurence John and Janice Nancy (Mrs), "Marowrie", Piney Range, Grenfell, N.S.W.	22.50	"	"
Andrea, Agatha (Miss) and F. and J. Carriage, P.O. Box 1003, Boroko, P.N.G.	12.77	"	"
Andrews, Elizabeth (Mrs), Division of District Administration, Dept. of Administrator, Aitape, WSD, P.N.G.	12.77	"	"
Anutrof Pty. Ltd., c/o M. Garling, 2 Langley St, East Sydney, N.S.W.	31.94	"	"
Archer, Helen Susan (Miss), "Fairview", Tarcutta Mail, Wagga Wagga, N.S.W.	11.97	"	"
Barkley, Wayne Graham, Maldanna, Ulamambri, N.S.W.	19.16	"	"
Barrie, Lynette Blyth (Mrs), 3 Glebe Ave, Cheltenham	85.64	"	"
Bell, Morton, c/o Slough Estates Australia Pty. Ltd., 233 Collins St, Melbourne	14.00	"	"
Bertie, Susan Griselda Ann Lyon (Mrs), c/o National Westminster Bank Ltd., 7 High St, Bracknell, Berkshire, U.K.	33.47	"	"
Bibic, Roberta (Mrs), 16 The Pass, Croydon South	35.00	"	"
Bird, Lilian Alison (Mrs), 386 Pages Rd, Christchurch 7, N.Z.	10.19	"	"
Black, Peter Rupert Dill (Dr), 2 Gawler Tce, Walkerville, S.A.	30.01	"	"
Boito, Percy Leonard Ross, P.O. Box 702, Katanning, W.A.	16.07	"	"
Boskovic, Nicola, 10 Watson Ave, Box Hill North	19.16	"	"
Bragg, Bruce Gunson, Bonnie Gowan, Guyra, N.S.W.	13.80	"	"
Bresnehan, Fr. T. (Rev), P.O. Box 362, Devonport, Tas.	13.50	"	"
Brice, Sheila Margaret (Miss), Flat 11, 97 Chomley St, Windsor	12.77	"	"
Briggs, Susan Helga (Miss), P.O. Box 135, Kalamunda, W.A.	10.00	"	"
Brostoff, David Mark, 84A Kambala Rd, Bellevue Hill, N.S.W.	17.50	"	"
Burleigh, Diana Georgina (Miss), 10/11 William St, Frankston	27.12	"	"
Busby, D. G., Busby's Langwood Hotel, 250 Queen's Promenade, Bispham Fy2p HA, U.K.	27.96	"	"
Cable, Anthony Leigh, 23 Rivers St, Bellevue Hill, N.S.W.	10.35	"	"
Caygill, Bruce Allott, 254 Innes Rd, Christchurch 5, N.Z.	44.80	"	"
Chaytor, Anthony David Clervaux, Marshlands, Blenheim Rd, 3, N.Z.	21.42	"	"
Chee, Cedric, c/o C. and B. Chee Pty. Ltd., P.O. Box 214, Lae, P.N.G.	12.77	"	"
Clarke, Anna Williams (Mrs), 43 Nelson Rd, Lindfield, N.S.W.	13.08	"	"
Clay, Ellen Anne Bothwell (Mrs), 43 Mawarra St, Chevron Island, Qld.	53.23	"	"
Colegrove, John Wesley, G.P.O. Box 4981, Sydney, N.S.W.	10.65	"	"
Collingridge, Francis Hugh, c/o Bank of N.S.W., Royal Exchange, Sydney, N.S.W.	27.30	"	"
Colpoys, Dorothy Josephine (Miss), Ponders End, 46 Barton Rd, Torquay, Devon, U.K.	22.31	"	"
Conti, Janis Patricia (Mrs), 4 Mandella St, Templestowe	11.80	"	"
Cretser, Samuel Neil, c/o Bechtell Wke, P.O. Box 12, Kieta, P.N.G.	12.77	"	"
Crick, Joan Mary (Mrs), 33 Glenfern Rd, Howick, N.Z.	14.51	"	"
Curtis, John Vaughan, 48 Diamond St, Kingston, Qld.	12.77	"	"
Curwen-Walker, Peter Dermontt (Dr), c/o Bank of N.S.W., 229 Collins St, Melbourne	12.77	"	"
Darragh, Roderick Selwyn, 6 Hiscock St, Chadstone	11.90	"	"
Davies, Iris Jean (Mrs), 6 Strelley Dr, Goldsworthy, W.A.	13.36	"	"
De Baisac, Mary Katherine (Mrs), c/o National Provincial Bank Ltd., 88 Cromwell Rd, London SW7, U.K.	33.47	"	"
Donegan, Ronald Lewis, P.O. Box 68, Markham Valley, Lae, P.N.G.	26.61	"	"
Doyle, Vincent (Rev), Parish of Immaculate Heart of Mary, Catholic Mission, Kunjigini, Wewak, P.N.G.	12.77	"	"
Dunn, Allan Raymond, 11 Ferretti Gve, Lower Hutt, N.Z.	63.87	"	"
Eccles, John Mark, P.O. Box 93, Port Moresby, P.N.G.	10.20	"	"
Edwards, Mallee Brumby (Miss), 14/75 Elizabeth Bay Rd, Elizabeth Bay, N.S.W.	10.50	"	"
EG and H Nominees Pty. Ltd., 421 Bourke St, Melbourne	26.99	"	"
Ellis, Alfred Garnet, 6 Ramage Pl, Flynn, A.C.T.	53.23	"	"
Eyre, Jane Elizabeth (Miss), 24 Stafford Mansions, Stafford Pl, London SW1, U.K.	12.68	"	"
Ezra Developments Pty. Ltd., 6th Floor, 446 Collins St, Melbourne	20.00	"	"
Farrelly, Keith James, c/o J. G. Farrelly, Casuarina Ave, Lae, P.N.G.	12.77	"	"
Fernandez, Tomas, 4/27 Berwick St, Coogee, N.S.W.	17.60	"	"
Fillery, Thelma Margaret (Mrs) and Donald Edwin, All Nations Hotel, 331 Eyre St, Broken Hill South, N.S.W.	11.12	"	"
Fitzgerald, Edward Albert, c/o R. A. Smith, 25 Bassett Ave, Southampton, Hants, U.K.	26.61	"	"
Flynn, Keith, 3 Hillcrest Ave, Ringwood	14.28	"	"
Flynn, Keith Edmund, 3 Hill Crest Ave, Ringwood	13.89	"	"
Ford, Kenneth Leslie Shannon, Flat 37, 20 Shirley Gve, St. Kilda East	22.56	"	"
Ford, Muriel Beryl (Mrs), 13 Dencourt Cres, Basildon, Essex, U.K.	20.34	"	"
Fox, Eve Lena (Miss), P.O. Box 63, Mt. Hagen, P.N.G.	12.77	"	"
Freeth, Michael James (Dr), c/o The Manager, A.N.Z. Bank Ltd., 84 St. Georges Tce, Perth, W.A.	11.07	"	"
Gallagher, Denise Carmel (Miss), 377 Milton Rd, Auchenflower, Qld.	12.00	"	"
Gascoigne, Margaret Elizabeth (Mrs), 80 Innes Rd, Manly Vale, N.S.W.	16.92	"	"
Gellie, Jennifer Joan (Mrs), 24 Lenthall St, Kensington, N.S.W.	106.45	"	"
Gho, Lian Chin, 57 Warburton Rd, Canterbury	45.00	"	"

Unclaimed Moneys Act 1962

Register of Unclaimed Moneys held by the—

Name of Owner on Books and Last Known Address	Total Amount Due to Owner	Description of Unclaimed Money	Date when Amount first became Payable
S			
GROUP SHARE REGISTRY PTY. LIMITED—continued			
Glasby, Arthur Hilton, 50 Joffre St, Ashgrove, Qld.	19.16	Dividend	3.11.78
Glasson, Lynne Cheryl (Miss), 37 Burt St, Mt. Lawley, W.A.	16.21	"	"
Glesinger, Bernhard, 92 The Boulevard, Floreat Park, W.A.	17.64	"	"
Gooch, Neville Thomas, 30 Mitre St, St. Lucia, Qld.	12.77	"	"
Goodrick, John Percival, P.O. Box 76, Te Awamuto, N.Z.	12.77	"	"
Goodwin, Joyce May (Mrs), P.O. Panguna, P.N.G.	33.83	"	"
Gordon, Keith Battersby, c/o The Manager Bank of N.S.W., 111 Crown St, Wollongong, N.S.W.	19.54	"	"
Gordon, Kenneth Graham, 51 Tully St, Townsville, Qld.	10.65	"	"
Grabinski, Jerzy Witold, 135 Walford Dr, Moraga, Calif. 94556, U.S.A.	19.16	"	"
Grover, John Charles, P.O. Box 419, Spit Junction, N.S.W.	15.97	"	"
Haber, Harry Fred (Dr), 14 Liverpool Rd, Croydon, N.S.W.	12.32	"	"
Hannah, David (Jnr), St. Helena, Armidale, N.S.W.	31.22	"	"
Hansen, Peter Finlay, c/o BCPL B39, Panguna, Bougainville, P.N.G.	22.36	"	"
Harel, Monigque (Mrs), 22 Kingsway, Nedlands, W.A.	51.10	"	"
Harp, Joel, Unit 2, 75 Fitzwilliam Rd, Vaucluse, N.S.W.	10.50	"	"
Harrington, Kevin Edward, 8 Robert Crt, Morwell	12.77	"	"
Harris, Keith Arthur, 16 Botanic Dve, Glen Waverley	19.80	"	"
Hedigon, Helen Mary (Mrs), Springfields, Rosehill Rd, Lower Plenty	13.72	"	"
Helbig, Judith Marie (Mrs), P.O., Mary Kathleen, Qld.	15.53	"	"
Hellmund, Heinrich, Industriestr 42, 473 Ahlen (WESTF), W. Germany	15.98	"	"
Henderson, George Sinclair (Dr), c/o Mrs E. J. Dalgarno, 11 Milton St, Heathmont	12.77	"	"
Hill, Enid Ruth (Mrs), 1 Short St, Mudgee, N.S.W.	15.54	"	"
Hocknell, William, c/o Lloyds Bank Ltd., Mercer Row, Louth, Lincs, U.K.	34.04	"	"
Hohnen, Giles John, P.O. Box 110, Margaret River, W.A.	11.07	"	"
Hovell, Susan Margaret (Mrs), 15 Taylor Rd, Claremont, W.A.	10.65	"	"
Howard, Kevin, 24 Queen St, Bowral, N.S.W.	17.50	"	"
Howell, Bernice Christine Solange (Mrs), c/o Craftman's Market Singapore, 419 River Valley Rd, Singapore 10, Singapore	19.16	"	"
Hoyem, Rona (Dr), c/o Bank of N.S.W., Broken Hill, N.S.W.	14.53	"	"
Hudson, Kenneth, Block A, Flat 33, Banool Ave, Woomera, S.A.	28.00	"	"
Hunt, Lance Pretoria, Cape Nelson Rd, Portland	14.15	"	"
Hunter, Stephen Bennet Puckett, 9 Derby Pde, Caulfield North	10.35	"	"
Ireland, Mary Eloise Johnstone (Mrs), Bardleden Farm, Smarden, Ashford, Kent, U.K.	16.01	"	"
Jackshell Pty. Ltd., 32 Lyndhurst Cres, Hunters Hill, N.S.W.	18.10	"	"
Jackson, M. H. L. (Miss), c/o National Westminster Bank Ltd, 288 Green Lanes, London N13 5TN, U.K.	61.14	"	"
Jasinique, Pty Ltd., P.O. Box 52, Rabual, P.N.G.	13.26	"	"
Jenke, Mary Phyllis (Mrs), House No. 8 Lilac St, Tom Price, W.A.	35.13	"	"
Jessop, June Catherine (Mrs), P.O. Box 36, Stockton, N.S.W.	10.65	"	"
Johnson, Jeremy Christopher, Apt 3701 1650 Ala Moana Boulevard, Honolulu 96815, Hawaii	12.77	"	"
Johnson, Neil Douglas, 17 Hartington St, Kew	10.50	"	"
Johnson, Philippa Carmel St. John (Mrs), 6/62 Ocean St, Woollahra, N.S.W.	10.99	"	"
Jones, Agnes Dora (Mrs), Cliff Edge, Pant, Oswestry, Shropshire, U.K.	26.77	"	"
Kailola, Herman Daniel and Patricia Joan (Mrs), c/o P.N.G. Development Bank, P.O. Box 500, Port Moresby, P.N.G.	12.77	"	"
Kalb, Bernard, C.B.S. News, 2020 M Street, N.W., Washington DC 20036, U.S.A.	18.89	"	"
Kalb, Bernard and Phillis (Mrs), C.B.S. News, 2020 M Street, N.W., Washington DC 20036, U.S.A.	14.66	"	"
Kearney, Jessie Alice Elizabeth (Mrs), c/o Mr and Mrs L. Yung, 70 Thirteenth St., Warragamba, N.S.W.	21.29	"	"
Keith, Desmond Travers, P.O. Box 56, Willaston, S.A.	10.65	"	"
Kelly, Sheila Sylvia (Miss), Lot 12, Dickasons Rd and Greenway, Heathmont	10.35	"	"
Kramer, Karl Jacob Thomas, P.O. Box 270, Wewak, P.N.G.	12.77	"	"
Lagoni, John Frederick Christian, P.O. Box 6555, Boroko, P.N.G.	26.61	"	"
Laing, Ivy (Miss), Unit 62, 107 Darling Point Rd, Darling Point, N.S.W.	118.82	"	"
Lane, Bruce Alistair, West Rd, Clevedon, N.Z.	10.65	"	"
Leeds, Glenn Anthony, 31 Brooklyn Rd, Brooklyn, N.S.W.	10.65	"	"
Leigh, Noel Patricia (Dr), c/o National Westminster Bank Ltd., 332 High Holburn, London WC1, U.K.	10.91	"	"
Lenz, Rudolf, BSD Barracks 13, 8000 Munich 80, Krumbad Str 17/0, W. Germany	12.77	"	"
Letzer, Gwendoline Ann (Mrs), 1 Ina Ct, Weipa, Qld.	28.78	"	"
Linder, Dorothy Alison (Mrs), 20 Bayview Rd, Burraneer Bay, N.S.W.	31.94	"	"
Lockwood, Laurence Robert, Flat 8, 746 Beaufort St, Mt Lawley, W.A.	15.05	"	"
Lohberger, John, Taxation Dept., P.O. Box 777, Port Moresby, P.N.G.	10.65	"	"
Lovis, Harriett Eliza (Mrs), 20 Holly Lane West, Banstead, Surrey, U.K.	13.38	"	"
Macgregor, Mary Winton (Mrs), c/o Warwick Hospital Board, Locke St, Warwick, Qld.	10.50	"	"
Mackinnon, Sheila Valeria (Mrs), 2 Sangrado St, Seaforth, N.S.W.	42.00	"	"
Madden, Raymond Francis, 20 Alanas Ave, Dundas, N.S.W.	36.00	"	"
Malden, Antony Charles (estate of), c/o Northcote and Co., P.O. Box 548, Cophthall CL, London EC2P 2JJ, U.K.	54.70	"	"

Unclaimed Moneys Act 1962

Register of Unclaimed Moneys held by the—

Name of Owner on Books and Last Known Address	Total Amount Due to Owner	Description of Unclaimed Money	Date when Amount first became Payable
S			
GROUP SHARE REGISTRY PTY. LIMITED—continued			
Malvezzi, Giovanni, 6 Parc De Bearn, Saint-Cloud 92, France	38.25	Dividend	3.11.78
Manetta, Henry Louis, 41 Grandview Gve, Toorak Gardens, S.A.	10.24	"	"
Mankey, Judith Ann (Mrs), Lot 16, Bungarra Cres, Moorebank, N.S.W.	14.60	"	"
Manlon, Keith Denis, 117 Pitt St, Sydney, N.S.W.	13.20	"	"
Manser, Peter Frederick, P.O. Box 635, Madang, P.N.G.	12.77	"	"
Marano, Emilio, 199 Berkeley St, Carlton	10.65	"	"
Martin, George Raymond and Constance Frances (Mrs), c/o Bank of N.S.W., P.O. Box 92, Coolangatta, Qld.	35.20	"	"
Martin, Sandra Robyn (Mrs), 293 Pacific Hwy, Crows Nest, N.S.W.	31.94	"	"
McCabe, Noelle Maree (Mrs), P.O. Box 795, Madang, P.N.G.	12.77	"	"
McCaughey, Samuel A. (estate of), c/o Peter F. Daly and Co., P.O. Box 362, Woollongong East, N.S.W.	58.60	"	"
McCausland, John, c/o Ray White Pty. Ltd., 260 Queen St, Brisbane, Qld.	26.47	"	"
McCorry, Sheryl (Mrs), c/o A.N.Z. Banking Group Ltd., 33 Loch St, Derby, W.A.	10.50	"	"
McGuinness, John Henry and Mary Patricia, P.O. Box 543, Arawa, P.N.G.	33.53	"	"
McGuane, Barry John, P.O. Box 1373, Mt. Isa, Qld.	11.12	"	"
McKee, Alistair Tasman Joseph, P.O. Box 18, Rotowaro, Huntly, N.Z.	21.92	"	"
McKinnery, William George, 210 Robin Rd, Hillsborough, Cal. 94010, U.S.A.	12.77	"	"
McLeod, Lindsay Angus, c/o Bank of N.S.W., P.O. Box 172, Kieta, P.N.G.	15.97	"	"
McNally, Kenneth Francis, Keravat High School, Rabaul, P.N.G.	11.17	"	"
Miller, Jessie Unity, c/o Anderson James and Willis, P.O. Box 40, Bexley, N.S.W.	21.72	"	"
Miller, John Alan Fortey, 75 Oxley Rd, Hawthorn,	14.00	"	"
Mitchell, Angela Marion (Miss), "Ashens", Rocky Gully, W.A.	22.00	"	"
Moffat, William Thomas and Jane Nancy (Mrs), 2201 Ambassador Rd, Albuquerque 87112, U.S.A.	10.67	"	"
Moffitt, Patrick Barry, c/o Mrs E. L. Moffitt, 1/5 Denham St, Hawthorn	19.67	"	"
Murphy, Deborah (Mrs) and Thomas, APT 63A, 280 River Rd, Piscataway NJ 08854, U.S.A.	38.25	"	"
Murphy, James Roney Keogh (Major), c/o National and Grindlays Bank Ltd., 13 St. James Square, London SW1, U.K.	40.16	"	"
Murray, Michael Frederick and Gina Ann (Mrs), Westminster School, Marion, S.A.	13.32	"	"
Musgrave, Stuart, Adaville, Ballintemple, Cork, Eire	19.16	"	"
Napier, W. I., c/o Muthaiga Country Club, P.O. Box 30181, Nairobi, Kenya	14.70	"	"
Ng, Meiguin (Mrs), 28 Edgar St, Chatswood, N.S.W.	53.23	"	"
Nicoll, Michael Roderick (Dr), William St, Beaudesert, Qld.	35.15	"	"
Northeast Pty. Ltd., 7 Atchison St, St. Leonards, N.S.W.	10.89	"	"
O'Brien, Edward James, 6/65 Maroy St, New Farm, Qld.	18.28	"	"
O'Donnell, John Michael and Stewart, David Murray, c/o John Proctor, 1 Gundarun St, Wollongong West, N.S.W.	10.36	"	"
Okura, Tokuji, G.P.O. Box 4472, Sydney, N.S.W.	22.32	"	"
Ough, Norman Clarence, Unit 2, 26 Bowmore Rd, Noble Park	20.00	"	"
Parsons, James Stewart, 277 Auburn Rd, Hawthorn	14.83	"	"
Peckover, Anne (Miss), P.O. Box 783, Port Moresby, P.N.G.	12.77	"	"
Phillips, Elaine Mabel (Mrs), 147 Union Rd, Surrey Hills	26.61	"	"
Phillips, Maurice Henry, 15 Dettman Ave, Longueville, N.S.W.	38.22	"	"
PHW Investments Pty. Ltd., c/o P. H. Winkless, 1 Lachlan Ave, Sylvania Waters, N.S.W.	14.28	"	"
Pollock, William Miller, c/o Mrs W. Spears, Ipstones Kennells, RD5, Makara, Wellington, N.Z.	47.90	"	"
Pozzobon, Richard, 14 The Parade, Drummoyne, N.S.W.	10.65	"	"
Pretsch, Felix Harry, 127 Cabana APTS, 516s Glenn Ave, Auburn, Alabama 36830, U.S.A.	10.71	"	"
Prisk, Shirley Ismay (Mrs), c/o Mrs S. J. Bick, 39 Sussex St, Brighton	11.12	"	"
Pritchett, Constance Mary (Mrs), Flat 12, 21 Elamang Ave, Kirribilli, N.S.W.	12.77	"	"
Pyke, John Joseph, 13 Widford St, Hawthorn East	26.70	"	"
Rainbow Investments Pty. Ltd., c/o 14th Floor, 447 Collins St, Melbourne	62.58	"	"
Ramp Pty. Ltd., P.O. Box 123, Hurstville, N.S.W.	63.87	"	"
Rayner, Lois Edith Hume (Mrs), Flat 6, 5 Ellamatta Ave, Mosman, N.S.W.	10.35	"	"
Reed, Barry, 8 William Lane, Broken Hill, N.S.W.	22.36	"	"
Reid, Kenneth John, c/o Mr E. F. Griffiths, 754 Station St, Box Hill	15.53	"	"
Richards, Elizabeth Ena (Miss), 461 Stirling Hwy, Cottesloe, W.A.	22.32	"	"
Rodger, Elizabeth Wilson (Mrs), 10 Glenlockhart Bank, Edingburgh EH14 LB4, U.K.	42.07	"	"
Roper, Geoffrey Victor (estate of), c/o Mr R. F. Long, 27 Almonbury Rd, Mt. Lawley, W.A.	32.90	"	"
Sadleir, Christopher, 21 Abbott St, Cairns, Qld.	31.62	"	"
Saint, Harold Francis, 10 Wilkinson Ave, Somerton, S.A.	36.32	"	"
Sanderson, John Stuart Shortreed, 7 De Beauvoir Square, London N1, U.K.	14.87	"	"
Sayres, Millicent Anna (Miss), 91 St. Mary Mansions, Paddington, London W2, U.K.	59.50	"	"
Setu, Ami Chand, P.O. Box 62, Emerald, Qld.	20.49	"	"
Simpson, Warwick Emslie, 43 Wairoa St, Waikari, Dunedin, N.Z.	12.77	"	"
Smalley, George Arnold (estate), c/o Hall and Corbin, Red Gables, 1 Harestone Valley Rd, Caterham Surrey CR36YP, U.K.	13.14	"	"

Unclaimed Moneys Act 1962

Register of Unclaimed Moneys held by the—

Name of Owner on Books and Last Known Address	Total Amount Due to Owner	Description of Unclaimed Money	Date when Amount first became Payable
\$			
GROUP SHARE REGISTRY PTY. LIMITED— <i>continued</i>			
Smith, Florence May, (Mrs), P.O. Box 285, Mackay, Qld.	38.36	Dividend	3.11.78
Sorrell, John Leonard (Captain), 105-D Meyer Crt, Meyer Rd, Singapore 15, Singapore	22.84	"	"
Squire, William Joseph, P.O. Box 110, Panguna, P.N.G.	25.74	"	"
Stonyer, Eric James, 12 Cluny Ave, Kelburn, Wellington 5, N.Z.	15.32	"	"
Street, Charles, P.O. Box 5614, Boroko, P.N.G.	12.77	"	"
Tapper, John, 4/1A Murdoch St, Cremorne, N.S.W.	26.61	"	"
Thompson, Phyllis Elizabeth (Mrs), 4 Eliza St, Black Rock	10.65	"	"
Thompson, Betty (Miss), 229 Kooyong Rd, Elsternwick	12.25	"	"
Torenius, Tuula Marjetta (Miss), RSD, Mt. Buller Rd, Merrifig	31.94	"	"
Turner, Archie Campbell, 229 Owen B'vard, Willowdale, Ontario, Canada	63.87	"	"
Waddilove, John, 19 Haunui Rd, Pukerua Bay, Wellington, N.Z.	19.95	"	"
Ward, David Anthony, P.O. Box 1238, Wellington, N.Z.	12.05	"	"
Warner, Phyllis Mary (Mrs), 11 Hawke Cres, Beachlands, Auckland, N.Z.	10.20	"	"
Watts, James McKinnon, 118 Summerhill Rd, Glen Iris	15.97	"	"
Webster, Neville, G.P.O. Box 2210, Brisbane, Qld.	10.39	"	"
Welland, Desley Fay (Mrs), P.O. Box 2895, Darwin, N.T.	12.77	"	"
White, Constance (Miss), Unit 4, 31/33 William St, Double Bay, N.S.W.	66.11	"	"
White, Margaret (Estate of), c/o Mr W. D. White, P.O. Box 199, Werribee	13.20	"	"
Williams, Christine Isobel (Mrs), Swallow St, Slade Point, Qld.	38.92	"	"
Williams, Ian Thomas, P.O. Box 42, Ravenshoe, Qld.	12.77	"	"
Williams, Leonard Cecil, 1 Majella Crt, Kew	10.86	"	"
Williams, Lesly Jane (Mrs), 136 La Perouse St, Griffith, A.C.T.	13.46	"	"
Willis, Laurel Jean (Mrs), 24 Nott St, Balwyn	13.50	"	"
Wilson, Mackenzie James, 6/43 Moruben Rd, Mosman, N.S.W.	19.74	"	"
Wood, Peggy Alice (Mrs), Flat 6, 135 Mitchell St, North Ward, Townsville, Qld.	15.53	"	"
Woodlock, Joan Gabrielle (Mrs), 5/10 Curzon St, Ryde, N.S.W.	11.71	"	"
Wren, Kathleen Ruby (Miss), Residence No 2, Balimo, P.N.G.	12.77	"	"
Wyndham Ward Pty. Ltd., 55 Church Tce, Walkerville, S.A.	73.59	"	"
Yip, Sarah (Miss), 1013 Dandenong Rd, Malvern East	12.77	"	"
5834			
THE RIO TINTO-ZINC CORPORATION LIMITED			
Bertram Investments Pty. Ltd., 259 Castlereagh Street, Sydney, N.S.W.	56.76	Dividend	2.1.79
Cable, Anthony Leigh, 23 Rivers St, Bellevue Hill, N.S.W.	42.52	"	"
Carnegie, Christopher Graham, 11 Cove St, Turramurra, N.S.W.	13.52	"	"
Johnsen, Maureen Roumea, Unit 10, 23-27 Diamond Way Rd, Vaucluse, N.S.W.	14.17	"	"
McLaughlin, Lynne (Mrs), 46 Edgecliff Rd, Woollahra, N.S.W.	12.01	"	"
Parsons, Charles Riviere and Mrs Pamela Vera Cahill, 10 Burroway St, Neutral Bay, N.S.W.	130.07	"	"
Reay, Irene Elizabeth (Mrs), c/o Jacoby Mitchell and Co., 469 Kent St, Sydney, N.S.W.	12.61	"	"
Ryan, Rosemary Elizabeth (Mrs), 16 Gore St, Fitzroy	47.27	"	"
Toohey, Joseph Francis, Springbank	12.62	"	"
Trowbridge, Robert Ralph, 161 Parsonage Rd, Castle Hill, N.S.W.	52.48	"	"
5836			
NATIONAL CONSOLIDATED LIMITED			
Berger, Denise E., 6/76 Pakington St, St Kilda	44.00	Dividend	1.5.78
Richards, Florence M., 213 Mill St, Ballarat	59.40	"	"
Saywell, Tom A. R. (estate of), 22 Drumalbyn Rd, Bellevue Hill, N.S.W.	19.80	"	"
Smith, Guy W. and Nola E. (estates of), c/o Caplice and Kelly, 1049 Victoria Rd, West Ryde, N.S.W.	39.60	"	"
Dalzell, Graham H., 52 Huntsbury Ave, Christchurch, N.Z.	67.32	"	"
Innes, Sydney, 18 Monroe St, Apt. 8 Grenada, Mississippi, U.S.A.	11.47	"	"
Palmer, Alma T., 13 Hanene St, St Helvers Bay, Auckland, N.Z.	30.60	"	"
Dallywater, Samuel W., c/o Bank of N.S.W., Alinga St, Canberra, A.C.T.	79.20	"	"
Etherington, Frank, 30 Norham St, North Perth, W.A.	39.60	"	"
Francis, Catherine J., Flat 3, 104 Chiter Ave, Ramsgate, N.S.W.	55.00	"	"
Lane, Mary L. M., 1 Redford St, Warrnambool	30.00	"	"
Mollison, Doris and Brenton G., 5 Wilkinson Ave, Somerton Park, S.A.	99.00	"	"
Osment, David H., Glenbrook, Baynton	31.70	"	"
Stein, Natalie, c/o A.N.Z. Bank Ltd, 351 Collins St, Melbourne	71.90	"	"
Taylor, Graeme J., Barastoc Farm, Central Ave, Croydon	27.00	"	"
Whippy, Denby J., 76 Hilton Ave, Lakemba, N.S.W.	45.50	"	"
Winn, Neelia H. G., 37 Brown St, Paddington, N.S.W.	21.00	"	"
Riddiford, Yvonne A., Cheviot Rd, Lowry Bay, Wellington, N.Z.	30.60	"	"
Shield Life Assurance Society Ltd. and Jones, Howard P., P.O. Box 1399, North Sydney, N.S.W.	57.90	"	16.11.78
Winneke, Nancy R., Government House, Melbourne	12.85	"	"
Lynch, Siabhra G., 62 Uplands Rd, Kelburn, Wellington, N.Z.	15.30	"	"
Greig, John M., 160 Baroona Rd, Rosalie, Qld.	21.45	"	"
Mackeson, Berth O. (estate of), c/o Allen and McFadden, P.O. Box 164, Toukley, N.S.W.	28.10	"	"
5837			

Unclaimed Moneys Act 1962

Register of Unclaimed Moneys held by the—

Name of Owner on Books and Last Known Address	Total Amount Due to Owner	Description of Unclaimed Money	Date when Amount first became Payable
\$			
THE RIO TINTO-ZINC CORPORATION LIMITED			
Geard, Elizabeth Jane (Mrs), Channel Hwy, Kingston, Tas.	14.70	Dividend	3.7.78
Jakobs, Harry Antonius Joseph and Edna Mary (Mrs), 9 Kendall St, Pymble West, N.S.W.	19.34	"	"
McGrath, Denis, 10 Woodland St, Wellington, N.Z.	23.20	"	"
Purbrick, Timothy Francis Stevens, Main Creek, Grafton South, N.S.W.	14.31	"	"
Reay, Irene Elizabeth (Mrs), c/o Jacoby Mitchell and Co., 469 Kent St, Sydney, N.S.W.	20.31	"	"
Toohy, Mary (Mrs), Springbank	20.31	"	"
Trestrail, Rosemary Winifred (Mrs), Annaleey, Armidale, N.S.W.	12.09	"	"
5835			
NATIONAL & GENERAL INSURANCE CO. LTD.			
Kalkéurp, K., c/o Hastings Caravan Park, Hastings	92.04	Premium	31.7.78
Reaburn, I., c/o Box 95, Hamilton	16.20	"	30.6.78
Cooke, M. H. and D. J., (address unknown)	62.52	"	31.12.78
Bird, B. A. and J. M., 371 Main St, Bairnsdale	16.88	"	29.4.78
Name and address unknown	48.40	Money Order	5.10.78
Crisp, T., 11/4 Dundas St, Thornbury	33.25	Premium	27.9.78
Colombine, R., 29 Howson St, Armadale	24.53	"	25.1.79
Bonacci, M., (address unknown)	31.00	"	20.8.78
Name and address unknown	300.22	Received in mail	1.12.78
Crackwell, J., 43/49 Park St, South Yarra	33.25	Premium	20.2.79
5838			
RALPH McKAY LIMITED			
Penny, Stella M. (Miss), c/o National Trustees, G.P.O. Box 2819 AA, Melbourne	12.00	Dividend	13.10.78
Dowling, Arthur E., (estate of), c/o Lander and Rogers, 140 Queen St, Melbourne	17.28	"	31.3.78
Lawrenny Pty. Ltd., 51 Queen St, Melbourne	13.82	"	13.10.78
Lewis, James R., 54 Canterbury Rd, Middle Park	10.22	"	"
Nixon, Norma K. B. (Mrs), c/o Sicree Nixon Watt and Co., G.P.O. Box 913G, Melbourne	23.40	"	"
Fraser, Donald Simon, P.O. Box 853, Singapore	25.50	"	"
5839			
ROBERT HUTCHINSON (HOLDINGS) LIMITED			
Briggs, Richard R., 6 Matlock Ave, Mulgrave	22.50	Dividend	28.4.78
Grundy, John Louis, 38 Reserve Rd, Beaumaris	64.50	"	"
Hume, Mary (Mrs), 401 St. Kilda Rd, Melbourne	12.60	"	"
Smith, Joan (Mrs), Lots 9 and 10 Shadforth St, Westmeadows	16.80	"	"
Taffs, Pearl Isobel (Mrs), 11 Randle St, Sydney, N.S.W.	105.00	"	"
Heifetz, Samuel and Hage, Jan L., 83 William St, Melbourne	28.80	"	10.11.78
Keeble, Margaret (Miss), 303 South St, Ballarat	10.00	"	"
Pacini, Mary L., 4/21 Lisson Grove, Hawthorn	12.00	"	"
Plunkett, John Roland, 7/48 Sutherland Rd, Armadale	10.80	"	"
Tuebor Pty. Ltd., c/o Sicree Nixon Watt and Co., P.O. Box 913G G.P.O., Melbourne	14.40	"	"
Wells, Bindi Anne, 83 Glanmire Rd, Baulkham Hills, N.S.W.	10.00	"	"
5840			
ROBERT HUTCHINSON LIMITED			
Philpott, E. M. (Mrs), Wilson St, Wedderburn	28.00	Dividend	30.6.78
Bott, E. B., Bull Plain, Corowa, N.S.W.	17.50	"	"
Carlier, S. (Mrs), 53 Croft Rd, Eleebana, N.S.W.	70.00	"	"
Smith, L. K. (Mrs), Wandong, Savernake, N.S.W.	14.00	"	"
5841			
OLIVER J. NIELSEN (AUSTRALIA) LIMITED			
Campbell, F. M. (Mrs), 32 Oakdene Cres, Murrumbidgee	48.00	Dividend	5.5.78
Shankly, N. J. (estate of), 406 Lonsdale St, Melbourne	52.91	"	"
Beveridge, R. J., 13 Hartwell Hill Rd, Hartwell	36.00	"	30.11.78
5842			
SIDNEY COOKE LIMITED			
Firino Pty. Ltd., 288 Brunswick St, Fitzroy	67.20	Dividend	31.8.78
Mitchell, Joseph W., 241 Kooyong Road, Elsternwick	90.00	"	"
Spechbach, Rene, c/o R. H. Spencer, P.O. Box 286, Cheltenham	38.16	"	"
Wightman, Kathleen J., 17 White St, North Fitzroy	26.40	"	"
McLaren, Duncan, 34 Vine St, Clayfield, Qld.	82.28	"	"
Burburdekin, John E. and Jill, 236 Bamba Rd, South Caulfield	14.40	"	28.2.79
Priddle, Claude E., 84 Tara St, Kangaroo Point, N.S.W.	10.40	"	"
5846			

Unclaimed Moneys Act 1962

Register of Unclaimed Moneys held by the—

Name of Owner on Books and Last Known Address	Total Amount Due to Owner	Description of Unclaimed Money	Date when Amount first became Payable
5			
THE SWAN BREWERY COMPANY LIMITED			
Ausdis Group Superannuation Fund Pty. Ltd., General Mutual House, 415-419 Bourke St, Melbourne	11.76	Dividend	— 6.78
Basinghouse Pty. Ltd., 9 Stanton Rd, Mosman, N.S.W.	14.98	"	— 12.78
Berlyn Investments Pty. Ltd., 103A Liebig St, Warrnambool	60.00	"	— 6.78
Brown, Helen O. (Miss), 33 Marlborough St, College Park, S.A.	63.84	"	"
Byrne, Margaret M. (Mrs), 3/24 Parnell St, Elsternwick	26.04	"	"
Coleman, Douglas R. and Wendy F. (Miss), 637 Toorak Rd, Toorak	39.61	"	"
Cooksey, Benedicta E. (Mrs), 53 Hatchlands Rd, Redhill, Surrey, U.K.	17.85	"	— 12.78
Donnellan, John D., 202 Tranmere Rd, Howrah, Tas.	59.37	"	— 6.78
Dumaresq, Marion A. (Miss), 957 Punt Rd, South Yarra	29.34	"	"
Elson Smith, Alfred J., Oban Cottage, Lilloco Rd, Warragul	120.19	"	— 12.78
Geddes, Margaret J. (Miss), Box 19, Lake Bolac	28.56	"	— 6.78
Hall, William G., P.O. Box 504, Sale	19.56	"	— 12.78
Hill, William, Springwood, Mount Rule Rd, Braddan, Isle of Man	138.52	"	— 6.78
Jays (Double Bay) Pty. Ltd., 100 Wolseley Rd, Point Piper, N.S.W.	37.50	"	"
Johnson, Isabel L. (Mrs), 32 Doncaster Rd, North Balwyn	60.00	"	"
Joske, Janice (Mrs), 3 Shrimpton Crt, Box Hill	12.78	"	"
Lowndes, Douglas B., Macpennys, Bransgore, Christchurch, Hants, U.K.	30.60	"	"
Moline, Margaret J. (Mrs), 30 Rosslyn St, Bellevue Hill, N.S.W.	52.82	"	"
Morrissy, John L., 8 Normandale Rd, East Bentleigh	12.00	"	"
Simmons, Agnes M. (Mrs), Goonoo, Brewarrina, N.S.W.	24.95	"	— 12.78
Southwick, Adelaide (Mrs), 4 Barnard Rd, Toorak	11.70	"	— 6.78
Steele, Priscilla A. H. (Mrs), P.B. 103, Camperdown	15.01	"	— 12.78
Stucki, Kurt, c/o G.P.O., Adelaide, S.A.	13.32	"	— 6.78
Suss, Sarah H. (Mrs), 3/14 Highbury Grove, East Prahran	12.00	"	"
Walden, Wanda L. (Mrs), 131 Avoca St, Randwick, N.S.W.	13.02	"	"
Webb, Ian S., 2/137 Cowper St, Goulburn, N.S.W.	12.00	"	"
5843			
STEIGER LIMITED			
M. and R. Butt Nominees Pty. Ltd., 405 Sydney Rd, Coburg	25.00	Dividend	8.3.78
Merfra Nominees Pty. Ltd., c/o Rezak and Associates, 3rd Floor, 390 St. Kilda Rd, Melbourne	25.00	"	"
5844			
McILWRAITH McEACHARN LIMITED			
Fratz, Beverley, 21 Bellevue Rd, East Bentleigh	22.50	Dividend	24.4.78
Thompson, Edward L., 111 Victoria St, Potts Point, N.S.W.	22.50	"	"
Sharp, Graham R., 13 Orana Ave, Cooma North, N.S.W.	28.13	"	1.11.78
5845			
WATTS HOLDINGS LIMITED			
Andrews, Alan R., 121 Sycamore St, South Caulfield	23.85	Dividend	7.4.78
Behren, Gerald and Mirelle, 60 Sutherland St, Paddington, N.S.W.	119.42	"	"
Wilson, John F., 76 Matheson Rd, Applecross, W.A.	108.49	"	"
Williams, Keith B., 13 Pine View Rd, Punchbowl, N.S.W.	13.20	"	27.10.78
Anderson, Robert K., 43 Princes St, Kew	12.55	"	"
Anderson, Ledley E., "Glenside", Box 39, Yea	29.00	Interest	14.11.78
5847			
BILL PATTERSON-CHENEY LIMITED			
Sharkie, Donald J., 2/16 Lawes St, Hawthorn	32.40	Dividend	21.4.78
5848			
LANES MOTORS (HOLDINGS) LIMITED			
Gillies, Donald F., 47 The Righi, Eaglemont	14.93	Dividend	29.4.78
Frilay, Gerard, 16 Bloomfield Rd, Ascot Vale	12.31	"	25.10.78
Gamble, Mary J. and Leo Vincent and Extton, Mary F. T., 3 Como Pde, Mentone	12.31	"	"
Lasky, Michael, 232 Carlisle St, Balaclava	43.31	"	"
Tucker, Harriet M., 15 Milford St, Burwood	12.31	"	"
5849			
CHEETHAM SALT CONSOLIDATED LIMITED			
McGlasson, Geoffrey C., 22 Power Tce, Port Lincoln, S.A.	11.52	Dividend	30.11.78
Schneider, Helen C. D., 43 Jannali Ave, Jannali, N.S.W.	31.12	"	"
5850			

Unclaimed Moneys Act 1962

Register of Unclaimed Moneys held by the—

Name of Owner on Books and Last Known Address	Total Amount Due to Owner	Description of Unclaimed Money	Date when Amount first became Payable
5			
JENNINGS INDUSTRIES LIMITED			
Bennett, Stanley H., 32 Zebina St, East Perth, W.A.	12.45	Dividend	23.3.78
Burrows, Peter W. J., c/o K. Burrows, 52 Barton St, Kogarah, N.S.W.	11.50	"	"
Chapman, Bruce and Valma, 274 Springvale Rd, Glen Waverley	35.00	"	"
Devlin, Francis J., "Oakdale", Main Rd, Mt. Dandenong	11.50	"	"
Edwards, John, 5/24 Bennett St, Cremorne, N.S.W.	11.50	"	"
Herkenhoff, Frederick A., P.O. Box 617, Fremantle, W.A.	25.00	"	"
Hindmarsh, Nellie D., 30 Lewis St, Eagle Junction, Qld.	27.25	"	"
Lanning, Hugh J. F., Settlement Rd, Swan Marsh	21.70	"	"
McConnell, Frederick, 18 Bettles St, Marmion, W.A.	23.20	"	"
McFarlane, Robert D., c/o Securities Dept., Bank of N.S.W., Looranah St, Jindalee, Qld.	30.00	"	"
O'Connor, Patrick, 177 Canning St, Carlton	17.40	"	"
Smith, Clifton, c/o Cooma Car Sales Pty. Ltd., Massey St, Cooma, N.S.W.	23.20	"	"
Sommer, Walter, 5/12 Kareda Rd, Cremorne, N.S.W.	173.65	"	"
Spiekman, Anthony, 775 Burwood Hwy, Ferntree Gully	19.00	"	"
Trifkovic, Michael, Block B, Room 18, Ainslie Hostel, Ainslie, A.C.T.	12.45	"	3.3.78
Trowbridge, Colin P., c/o 21 Yarraville Rd, Kew	19.85	"	23.3.78
Turner, Glen A. H., c/o 55 Sturt St, Brighton, S.A.	13.20	"	"
Carey, Alma F., 4 Woodmancote Rd, Khandallah, Wellington, N.Z.	27.03	"	"
Mackey, Anthony, Oldbury Grange, Hartshill, Nuneaton, U.K.	11.81	"	"
MacLaughlin, Sarah, Leewood House, Dunblane, Perthshire, U.K.	39.57	"	"
Robinson, Eric, 29 Cluny Hill, Singapore 10	84.91	"	"
Clarke, Nigel L., 9 Rushmead St, Malvern	13.40	Interest	30.6.78
Hills, Richard S., 71 Athelston Rd, Camberwell	15.40	"	"
Matear, Judith A., 241 Domain Rd, South Yarra	10.70	"	"
Allen, Peter A., 237 Coal Point Rd, Coal Point, N.S.W.	16.24	Dividend	"
Astle, Dorothy M., 56 St. Georges Cres, Faulconbridge, N.S.W.	60.00	"	"
Beattie, Alexander C., 54 Burns Rd, Wahroonga, N.S.W.	23.20	"	17.10.78
Bennett, Stanley H., 32 Zebina St, East Perth, W.A.	12.45	"	"
Bosher, Tim, 17 Victoria Ave, Broadbeach, Qld.	10.00	"	"
Busch, Denis R., c/o Warrego Mines, Tennant Creek, N.T.	20.00	"	"
De Rossi, Anthony F., U2/17 Sampson Rd, Mitchell Park, S.A.	12.45	"	"
Edwards, John, 5/24 Bennett St, Cremorne, N.S.W.	11.50	"	"
Grady, Alexander E. and Janice L., 1 McDairmid Ave, Pasedena, S.A.	23.20	"	"
Hindmarsh, Nellie D., 30 Lewis St, Eagle Junction, Qld.	27.25	"	"
Leonhardt, Herbert, 10 Henry St, Stuart Park, Darwin, N.T.	30.70	"	"
Lynch, John G., "Sunnyside", Ruthin Rd, Gwernymynydd near Mold, North Wales, U.K.	15.81	"	"
MacLachlan, Sarah, Leewood House, Dunblane, Perthshire, U.K.	39.57	"	"
Neville, William, 187 Piccadilly St, Kalgoorlie, W.A.	23.20	"	"
O'Connor, Patrick, 177 Canning St, Carlton	17.40	"	"
R. and R. Nominees Ltd., c/o Beardsley Bishop and Co., 21 New St, London EC2M 4NT, U.K.	74.29	"	"
Robinson, Eric, 29 Cluny Hill, Singapore 10	84.92	"	"
Silverbeck, Nathan and Brayde, Sydney and Wolfson, Bernard, c/o Silverbeck and Co., 17-19 Lord St, Liverpool, U.K.	39.57	"	"
Sommer, Walter, 5/12 Kareda Rd, Cremorne, N.S.W.	173.65	"	"
Trifkovic, Michael, Block B, Room 18, Ainslie Hostel, Ainslie, A.C.T.	12.45	"	"
Turner, Glen A. H., c/o 55 Sturt Rd, Brighton, S.A.	13.20	"	"
Bilzon, James H., 35 Wilberton Dr, Springvale	16.45	"	"
Bostock, Jennifer M., 19 Robinson Rd, Hawthorn	58.20	"	"
Clare, Shirley, c/o P. B. Clare, c/o Dept. of Trade and Industry, Canberra, A.C.T.	52.50	"	"
Devlin, Francis J., "Oakdale", Main Rd, Mt. Dandenong	11.50	"	"
Heard, Edwin P. M., 73 Atkinson St, Templestowe	18.25	"	"
Hyslop, George A., 1 Holroyd Cr., Blackburn South	14.00	"	"
Lanning, Hugh J. F., Settlement Rd, Swan Marsh	21.70	"	"
Mackey, Anthony, Oldbury Grange, Hartshill, Nuneaton, U.K.	11.82	"	"
Spiekman, Anthony W., 775 Burwood Hwy, Ferntree Gully	19.00	"	"
White, James E., 75 Copeland Rd, Beecroft, N.S.W.	23.20	"	"
Cawte, Frederick G. N., 332 Main South Rd, Morphett Vale, S.A.	36.02	Interest	31.12.78
Ridge, Mayhew J. and McColl, June B., 24 Gladstone St, Sandringham	90.18	"	"
5851			
R.V.B. LTD.			
Richardson, Dorothy M. (estate of), c/o A. J. Harrison and Co., Suite C, 414 Toorak Rd, Toorak	28.00	Dividend	19.5.78
Huntley, Veda, 4 Pilley St, East St Kilda	62.50	"	10.11.78
5852			
WINTERBOTTOM HOLDINGS LIMITED			
Monaghan, Mary A. (Mrs), 29 Patrick St, Stawell	25.00	Dividend	28.4.78
5853			

The Companies Act 1961, Section 254 (2)
D. C. THORNTON (VIC.) PTY. LIMITED

NOTICE OF RESOLUTION

To the Corporate Affairs Commission:

At an Extraordinary General Meeting of Shareholders of the abovenamed company held at 5th Floor, 23 Hunter Street, Sydney on Thursday, 8 May 1980 at 2.30 p.m. the following resolution was duly passed as a Special Resolution:

"That the Company be wound up voluntarily and that Mr Arthur John Forrest, Chartered Accountant, be hereby appointed Liquidator for the purpose of winding up the Company."

Dated 9 May 1980

7050

J. BELL, Secretary

Companies Act 1961—In the matter of FUTURE OF AUSTRALIA
FUND—Notice of Final Meeting

Notice is hereby given pursuant to Section 272 of the Companies Act that the Final Meeting of Members of the abovementioned company will be held at 9.00 a.m. on 16 June 1980 at 8th floor, 44 Market Street, Melbourne, where I shall lay before the meeting an account how the winding up has been conducted and the property of the company disposed of.

9 May 1980

7051

E. J. RAMSAY, Liquidator

The Companies Act 1961

FREEZEWAY REFRIGERATION CABINETS PTY. LTD.

PURSUANT TO SECTION 260 OF THE COMPANIES ACT 1961

Notice is hereby given that a Meeting of Creditors of Freezeway Refrigeration Cabinets Pty. Ltd., will be held at the offices of Touche Ross & Co., 12th Floor, 440 Collins Street, Melbourne on Thursday, 29 May 1980 at 3.00 p.m. for the purposes of considering the Company's affairs, the Company having convened an Extraordinary General Meeting of its Members to be held on Thursday, 29 May 1980 at 2.30 p.m. and for the purpose of considering and if thought fit passing a Special Resolution that the Company be wound up voluntarily.

Dated 14 May 1980

D. J. HUTCHINSON, Director

Touche Ross & Co., chartered accountants, 440 Collins Street, Melbourne, 3000 7052

Creditors next of kin and others having claims in respect of the Estate of Hazel Kathleen Walsh late of Flat 1, 48 Sutherland Road Armadale but formerly of 18 Lewisham Road Windsor Retired Public Servant deceased who died on 19 December 1979 are to send particulars of their claims to National Trustees Executors and Agency Company of Australasia Limited of 95 Queen Street Melbourne on or before 21 July 1980 after which date it will distribute the assets having regard only to the claims of which it then has notice.

R. P. BARRETT & SON, solicitors, 472 Bourke Street, Melbourne, 3000 6939

Creditors next of kin and others having claims in respect of the Estate of Dorothy Edna Hughes late of 27 Cumming Street West Brunswick, in the State of Victoria, Widow deceased, who died on 10 February 1980, are to send particulars of their claims to the Executor National Trustees, Executors and Agency Company of Australasia Limited of 95 Queen Street Melbourne, by 14 July 1980, after which date it will distribute the assets having regard only to the claims of which it then has notice.

LE GRANDE, RANGLES, GAFFNEY & CO., 644 Sydney Road, Brunswick, the solicitors for the applicant 6940

All persons having claims against the estate of Agnes Jane Curran late of 504 Nicholson Street (formerly known as 50 Nicholson Street) Ballarat Widow Probate of whose Will has been applied for by The Union-Fidelity Trustee Company of Australia Limited of 100 Exhibition Street Melbourne the Executor appointed by the said Will are hereby required to send particulars thereof in writing to

the said Company at its office at 101 Lydiard Street, North Ballarat on or before 24 July 1980 after which date the said Company will proceed to distribute the assets of the said deceased having regard only to the claims of which it shall then have had notice and the said Company will not be liable for the assets so distributed or any part thereof to any person of whose claim it shall not then have had notice.

R. G. DOBSON & CO., of 52 Lydiard Street South, Ballarat, solicitors for the said Company 6943

Creditors, next of kin and others having claims in respect of the Estate of Mary Maria Bath formerly of 42 Swanston Street; Geelong Home Duties but late of "Kalkee Hostel" Spring Street, Belmont, Spinster deceased, who died on 6 March 1980, are asked to send particulars of their claims to the Executor of the Will, The Union-Fidelity Trustee Company of Australia Limited of 100 Exhibition Street, Melbourne, by 14 July 1980 after which date the said Executor may convey or distribute the assets having regard only to the claims of which it then has notice.

F. R. APTED & SON, solicitors, 63 Yarra Street, Geelong 6944

Creditors, next of kin and others having claims in respect of the Will of Hanna Bailie Dott deceased late of 4/11A Murray Street, West Brunswick in the State of Victoria Home Duties deceased who died on 1 December 1979 and Probate has been granted to Patricia St. Clair Chapman of 177 Melville Road, West Brunswick in the said State are required to send their claims to the said Executrix care of the undermentioned Solicitors by 8 June 1980 after which date she will distribute the assets having regard only to the claims of which she then has notice.

ANDREW SPILVA, SIER & CO., solicitors of 160 Melville Road, West Brunswick, solicitors for the Executrix 6945

MADLINE TOOK, late of Redesdale, widow, DECEASED

Creditors, next of kin and others having claims in respect of the estate of the deceased who died on 3 July 1979, and Probate of whose Will was granted by the Supreme Court of Victoria on 20 September 1979, to Murray Bouchier Hall, of Calder Highway, Woodend, retired, Eric Ryder Baldwin formerly of Flat 4A 26 Eltham Avenue, Darling Point, N.S.W. but now of 57 Ellsa Street, North Balwyn, Engineer, and John Graham Bolton, of Kyneton, Solicitor, the executors therein named, are required to send particulars of their claims to the said executors in care of the undersigned solicitors before 15 July 1980, after which date they will distribute the assets having regard only to the claims of which they shall then have had notice.

PALMER, STEVENS & RENNICK, solicitors, 8 Jennings Street, Kyneton 6946

Creditors, next of kin and others having claims in respect of the Estate of Leslie Charles Davis late of corner Cliff Road and Violet Street, Frankston in the State of Victoria, formerly Director but late Retired deceased who died on 8 April 1980 are required to send particulars of their claims to the Executrix Mary Gertrude Davis care of Messrs Havyatt & Steward, Solicitors, 432 William Street, Melbourne by 24 July 1980 after which date the Executrix will distribute the assets of the deceased having regard only to the claims of which she then has notice.

HAVYATT & STEWARD, solicitors, 432 William Street, Melbourne 6947

ROBERT RAURICH JUDD, late of 9 Lawrance Street, Murrumbidgee pensioner, DECEASED.

Creditors, next of kin and others having claims in respect of the estate of the deceased who died on 5 March 1980 are required by the Executor John Frederick Sierakowski of 82 Poath Road Hughesdale to send particulars to him by 15 July 1980 after which date the said Executor will distribute the assets having regard only to the claims of which the said Executor then has notice.

JOHN F. SIERAKOWSKI, solicitor, 82 Poath Road, Hughesdale, 3166 6948

Creditors, next of kin and other persons having claims against the estate of John Francis Thynne late of Flat I, 14 Malakoff Street, Balaclava in the State of Victoria Technician deceased who died on 21 November, 1979 are required to send particulars of their claims to the Executor care of the undermentioned Solicitors by 16 July 1980 after which date the Executor will distribute the assets having regard only for the claims of which he then has had notice.

JAMES P. OGGE & CO. AND E. K. O'DONNELL, solicitors, of 165 Greville Street, Prahran 6970

Creditors, next of kin and other persons having claims against the estate of Evelyn Daphne Bagley late of 28 Jinjella Avenue, Ashwood in the State of Victoria Widow deceased who died on 19 November 1979 are required to send particulars of their claims to the Executor care of the undermentioned Solicitors by 16 July 1980 after which date the Executor will distribute the assets having regard only for the claims of which he then has had notice.

JAMES P. OGGE & CO. AND E. K. O'DONNELL, solicitors, of 165 Greville Street, Prahran 6971

Creditors, next of kin and others having claims in respect of the Estate of Sarah Victoria Missen late of Koo-Wee-Rup spinster deceased who died on 26 July 1979 are required by her executors Laurence John Cameron of Valencia Creek farmer and Nancy Mary Higgins of Prestons Road Koo-Wee-Rup widow to send particulars to them care of the undermentioned solicitors by 22 July 1980 after which date they will convey and distribute the assets having regard only to the claims of which they then have notice.

SEMMENS & HATCH, solicitors, 69 Johnson Street, Maffra, Vic. 3860 6972

Creditors, next of kin and others having claims against the estate of Lorna Winifred Broadbent late of 42 Cuthbert Street, Heathmont married woman who died on 19 February 1980 are required to send particulars of their claims to Mr and Mrs P. Booth of 6 Rothwell Court, Mitcham Victoria the Executors of her Will on or before 30 June 1980 after which date the said Executors will distribute the assets having regard only to the claims of which notice has been received.

KEITH LIONEL BAULD, late of 5 Roger Court, Nunawading, in the State of Victoria, retired purchasing officer, DECEASED

Creditors, next of kin and others having claims in respect of the estate of the deceased (who died on 2 December 1979) are required by the Executor, National Trustees Executors & Agency Co. of Australasia Ltd. of 95 Queen Street, Melbourne to send particulars to it, care of the undermentioned, on or before 25 July 1980 after which date it will distribute the assets having regard only to the claims of which it then has notice.

R. P. BAYLOR & CO., solicitors, 1 Walkers Road, Nunawading 6941

Creditors, next of kin and others having claims in respect of the Will of George Daniel Allingham late of 49 Richard Road, Melton South Pensioner who died on 24 February 1980 are requested to send particulars of their claims to the Executor Donna Janice Hitchcock care of the undermentioned Solicitor by 23 July 1980 after which date she will distribute the assets having regard only as to the claims of which she then has notice.

EDWARD CURMI, of 440 Victoria Street, North Melbourne 6942

Creditors, next of kin and others having claims in respect of the Estate of Winton George Turnbull late of 41 Putnam Avenue Bendigo, Retired deceased who died on 15 January 1980 are to send particulars of their claims to The Union-Fidelity Trustee Company of Australia Limited of 100 Exhibition Street Melbourne by 15 July 1980 after which date the said Company will distribute the assets having regard to the claims of which it then has notice.

R. WADHAM & DOIG, solicitors, of 383 Flinders Lane, Melbourne 6998

MILLICENT MAUD AGAR, late of 18 Barry Street, Kew, spinster, DECEASED

Creditors, next of kin, and others having claims in respect of the estate of the Deceased, who died on 4 October 1979, are required by the personal representative Arthur Henry Lewis of 72 Southernhay Street, Reservoir, Retired to send particulars to him by 16 July 1980, after which date the personal representative may convey or distribute the assets, having regard only to the claims of which he then has notice.

Dated 14 May 1980

LOUIS S. LAZARUS, solicitors, 389 Lonsdale Street, Melbourne, 3000 6996

Creditors, next of kin and others having claims against the Estate of James Bernard Meara late of 501 "Macley Regis" 12 Macleay Street Potts Point in the State of New South Wales, Gentleman deceased who died on 7 July 1979 are required by the Executors Terence Michael McMenamin of 186 Bathurst Road Katoomba in the State of New South Wales and Arthur James Downing of 121 William Street, Melbourne in the State of Victoria, to forward particulars of their claim to the said Executors care of the undermentioned Solicitors by 18 July 1980 after which date the Executors will distribute the assets having regard to the claims of which they will then have had notice.

F. J. ORAMES & DOWNING, solicitors for the executors, 121 William Street, Melbourne 6999

Creditors, next of kin and others having claims against the Estate of Edith Lilian Gresswell late of Hedley Sutton Home, 2-4 Gascoyne Street Canterbury Spinster deceased who died on 2 November 1979 are required by the Executor Arthur James Downing of 121 William Street, Melbourne in the State of Victoria, to forward particulars of their claim to the said Executor care of the undermentioned Solicitors by 18 July 1980 after which date the Executor will distribute the assets having regard only to the claims of which he will then have had notice.

F. J. ORAMES & DOWNING, solicitors for the executor, 121 William Street, Melbourne 7000

ANGUS ROBERTSON, O.B.E., late of 35 Beleura Hill Road, Morningson, in the State of Victoria, retired linen manufacturer, DECEASED

Creditors, next of kin and others having claims in respect of the estate of the deceased, who died on 18 November 1979 are required by the Trustees Gilbert James Farrow of 440 Collins Street, Melbourne in the said State Solicitor and William James Boyd Robertson of "Bow Butts" Kinghorn Fife in Scotland to send particulars to them care of the undersigned Solicitors by 21 July 1980 after which date the Trustees may convey or distribute the assets having regard only to the claims of which they then have notice.

WHITING AND BYRNE, 440 Collins Street, Melbourne 7001

Creditors, next of kin and all others interested in the estate of Gerald Albert Morris late of War Veterans Home, Overport Road, Frankston in the State of Victoria Gentleman deceased (who died on 12 December 1979) are required to send particulars of their claims to the Executor of the Will of the deceased Jack Meadows care of John W. McComas & Co., 325 Collins Street, Melbourne by 16 July 1980 after which date he will distribute the assets having regard only to the claims of which he then has notice.

JOHN W. MCCOMAS & CO., solicitors, 325 Collins Street, Melbourne 7002

Creditors, next of kin and others having claims against the estate of Robert Henry McCorkell late of "Braeside", Toolern Vale, Farmer Deceased who died on 7 February 1980 are to send particulars of their claims to the Executrix Maud Octavia McCorkell of "Braeside", Toolern Vale, Widow by 16 July 1980 after which date she will distribute the assets having regard only to the claims of which she then has notice.

PEARCE & WEBSTER, solicitors, 430 Little Collins Street, Melbourne 7005

LEONARD SYDNEY PAULIN, late of Hollis Road, Burleigh, retired, DECEASED

Creditors, next of kin and others having claims in respect of the estate of the said deceased, who died on 14 March 1980, are required by Alan Henry Robinson of 406 Lonsdale Street Melbourne Solicitor, the executor of the said Deceased, to send particulars to him by 31 July 1980, after which date the Executor may convey or distribute the assets, having regard only to the claims of which he then has notice.

PRENDERGAST & ROBINSON, PARKINSON & HART, solicitors, 406 Lonsdale Street, Melbourne 7006

BARBARA NEWTON, late of Unit 1, 5 Coppin Close, Mitcham, in the State of Victoria, widow, DECEASED

Creditors, next of kin and others having claims in respect of the Estate of the deceased who died on 23 November 1979 are required by the Executor Brian Redmond Smyth of 408 Collins Street Melbourne in the said State Solicitor to send particulars to the undermentioned firm by 31 July 1980 after which date the said Executor may convey or distribute the assets having regard only to the claims to which notice has by then been given.

SETON WILLIAMS & SMYTH, solicitors, 408 Collins Street, Melbourne 7007

Creditors, next of kin and others having claims in respect of the estate of Joyce Yewers late of Unit A 102/52 Darling Street South Yarra in the State of Victoria Retired Public Servant deceased who died on 20 February 1980 are required to send particulars of all claims to The Equity Trustees Executors and Agency Company Limited of 472 Bourke Street Melbourne in the said State on or before 16 July 1980 after which date the Executors will distribute the assets of the Estate having regard only to the claims of which they have had notice.

NICHOLAS O'DONOHUE & CO., solicitors, 493 Little Bourke Street, Melbourne, 3000 7008

Pursuant to the *Trustee Act 1958* notice is hereby given that all persons having claims against the Estate of Dionisia Livitsanos formerly of 32 Pakenham Street, Laburnum but late of 22 Witchwood Crescent East Burwood in the State of Victoria, Home Duties, Deceased who died on 31 December 1979 and Probate of whose Will was granted by the Supreme Court of the said State in its Probate Jurisdiction on 3 April 1980 to Christos Livitsanos of 10 Nith Court, Glen Waverley in the said State, Metallurgist and Dimosthenes Livitsanos of 11 Galea Crescent, Vermont in the said State, School Teacher are hereby required to send particulars in writing of such claims, to the said Christos Livitsanos and Dimosthenes Livitsanos care of the undermentioned firm of Solicitors on or before 18 July 1980 after which date the said Christos Livitsanos and Dimosthenes Livitsanos will proceed to distribute the assets of the said Dionisia Livitsanos Deceased which shall come to their hands amongst the persons entitled thereto, having regard only to the claims of which they shall then have notice. And notice is hereby further given that the said Christos Livitsanos and Dimosthenes Livitsanos will not be liable for the assets so distributed or any part thereof to any person of whose claim they shall not have had notice as aforesaid.

KEMPSON & GAY, solicitors, of Suite 6, 79 Mahoneys Road, Forest Hill 7009

MAVIS CLAIRE HARMAN, late of Unit 12, 740 Orrong Road, Toorak, widow, DECEASED

Creditors, next of kin and others having claims in respect of the estate of the deceased who died on 5 February 1980 are required by the executors Bronwyn Claire Harman Bailey of 10 Cedric Street Mordialloc Teacher and Rowan James Harman of 5 Meadow Court Blackburn South Advertising Consultant to send particulars to them care of the undermentioned solicitors by 16 July 1980 after which date the executors may convey or distribute the assets having regard only to the claims of which they then have notice.

HADEN SMITH & FITCHETT, solicitors, 423 Bourke Street, Melbourne 7003

Creditors, next of kin and others having claims in respect of the estate of Mary Margaret Dipell late of 8 Wakefield Street Hawthorn in the State of Victoria Retired who died on 4 February 1980, are to send particulars of their claims to The National Trustees Executors and Agency Company of Australasia Limited, of 95 Queen Street, Melbourne, in the said State the executor appointed by the Will of the said deceased by 18 July 1980 after which date the said Company will commence to distribute the assets having regard only to the claims of which it then has notice.

RENNICK & GAYNOR, solicitors, 427 Riversdale Road, Hawthorn East 7004

RODNEY VICKERS BRIEN, late of Macorna, in the State of Victoria, retired farmer, DECEASED

Creditors, next of kin and all other persons having claims against the Estate of the said Deceased, are required by John Rodney Brien of 4 Samuel Court, Caloundra in the State of Queensland and Luigi Charles Basile of Kerang in the State of Victoria the Executors of the Estate of the said deceased to send particulars of such claims to them in care of the undermentioned Solicitors on or before 8 July 1980 after which date they will distribute the assets having regard only to the claims of which they then have notice.

BASILE & CO., solicitors, 46 Wellington Street, Kerang, 3579 7031

TERESA VELLA, late of 3 Gilbert Street, Coburg, in the State of Victoria, widow, DECEASED

Creditors, next of kin and all others having claims in respect of the estate of Teresa Vella late of 3 Gilbert Street, Coburg Widow deceased who died on 22 October 1979 are required by the Executrix Cettina Borg of 8 Claremont Street, Fawkner Married Woman to send particulars of their claims to her in the care of the undermentioned Solicitor prior to 31 July 1980 after which date she will distribute the assets having regard only to the claims of which she then has notice.

M. F. HUGHES, LL.B., solicitor, of 300 Barkly Street, Brunswick 7032

HENRIETTA ROSANNA KIDD, late of 25 Mackinnon Street, Terang, widow, DECEASED

Creditors, next of kin and other persons having claims against the estate of Henrietta Rosanna Kidd late of 25 Mackinnon Street, Terang in the State of Victoria Widow deceased intestate who died on 8 September 1976 are required to send particulars of their claims to the Administrator, The Union Fidelity Trustee Company of Australia Limited of 100 Exhibition Street, Melbourne by 16 July 1980, after which date the Administrator will distribute the assets of the deceased, having regard only to the claims of which it then has had notice.

DAVID TRICKETT & FRANK GARSIDE, solicitors, 140 High Street, Terang 7033

DAPHNE MAY MULAVIN, formerly of 10 Boland Street, Burnley, in the State of Victoria, married woman, but late of 1 Johnston Street, Ashburton, in the said State, widow, DECEASED

Creditors, next of kin and others having claims in respect of the Estate of the deceased who died on 18 November 1979 are required by the Executrix Louise Elizabeth Hailes of Lot 21 Eucalyptus Road Eltham in the said State Married Woman to send particulars to the undermentioned firm by 31 July 1980 after which date the said Executrix/Administratrix may convey or distribute the assets having regard only to the claims to which notice has by then been given.

SETON WILLIAMS & SMYTH, solicitors, 408 Collins Street, Melbourne 7034

CLARISSA TITTERINGTON WILLIAMSON, late of "Annesley", 694 Whitehorse Road, Mont Albert, widow, DECEASED

Creditors next of kin and others having claims in respect of the estate of the deceased (who died on 24 February 1980) are required by The Perpetual Executors and Trustees Association of Australia Limited of 50 Queen Street Melbourne to send particulars of their claims to the said Company by 31 July 1980 after which date it will convey or distribute the assets having regard only to the claims of which the Company then has notice.

MARSHALL & MARSHALL, solicitors, 380 Lonsdale Street, Melbourne 7035

Creditors, next of kin and others having claims in respect of the Estate of Stewart Dunn late of 87 Princes Street, Korumburra, Retired, deceased who died on 5 December 1979 are to send particulars of their claims to Rita Lorna Tack care of the undersigned by 7 July 1980, after which date she will distribute the assets having regard only to the claims of which she then has notice.

MESSRS BIRCH, ROSS & BARLOW, solicitors, 28 Commercial Street, Korumburra 7036

NELLIE MURIEL MILLICENT JOUBERT, late of 12 Maleela Avenue, Balwyn, married woman, DECEASED

Creditors next of kin and others having claims in respect of the estate of the deceased who died on 15 January 1980 are required by The Perpetual Executors and Trustees Association of Australia Limited of 50 Queen Street Melbourne and Alan Joubert of 12 Maleela Avenue, Balwyn, Importer the applicants for a grant of administration to send particulars of their claims to the said applicants care of the said Company by 16 July 1980, after which date they will convey or distribute the assets having regard only to the claims of which they then have notice.

WEIGALL & CROWTHER, solicitors of 459 Little Collins Street, Melbourne 7037

CATHERINE PHILPOTT BROWN, late of 13 Gladstone Parade, Elsternwick, gentlewoman, DECEASED

Creditors, next of kin and others having claims in respect of the estate of the deceased (who died on 22 January 1980) are required by The Perpetual Executors and Trustees Association of Australia Limited of 50 Queen Street, Melbourne, to send particulars of their claims to the said Company by 22 July 1980, after which date it will convey or distribute the assets, having regard only to the claims of which the Company then has notice.

BEST, HOOPER, RINTOUL & SHALLARD, solicitors, 400 Little Collins Street, Melbourne, 3000 7038

Creditors and next of kin and others having claims in respect of the estate of Frances Dickson Shaw late of 85 Fortescue Avenue Seaford in the State of Victoria Widow deceased who died on 29 February 1980 are required by the executor Ian Frank Hoadley Ross of 147 Collins Street Melbourne in the said State Solicitor to send particulars of their claims to him care of the undermentioned Solicitors by 15 July 1980 after which date he will distribute the assets having regard only to the claims of which he then has notice.

DARVALL & HAMBLETON, solicitors of 147 Collins Street, Melbourne, 3000 7039

OLIVIA CAROLINE BREWER, late of 108 Argyll Street, Chadstone, widow, DECEASED

Creditors next of kin and others having claims against the Estate of the said deceased who died on 16 January 1980 are to send particulars of their claims to Mardi Olivia Oliver and Beth Elaine Findlay C/- Messrs Blake & Riggall Solicitors 140 William Street Melbourne by 13 August 1980 after which date they will distribute the assets having regard only to the claims of which they then have notice.

BLAKE & RIGGALL, solicitors, 140 William Street, Melbourne 7040

Creditors next of kin and others having claims in respect of the estate of Catherine Edith James late of 270 Auburn Road Hawthorn Widow who died on 21 November 1979 are to send particulars of their claims to Doris May McCurdy and Arnold Nankervis the executors care of the undersigned by 25 July 1980, after which date they will commence to distribute the assets having regard only to the claims of which they then have notice.

RENNICK & GAYNOR, solicitors of 427 Riversdale Road, Hawthorn East 7041

In the Supreme Court of the State of Victoria
SALE BY THE SHERIFF

On Wednesday 25 June 1980 at 12 noon at the Police Station, Stawell (unless process be stayed or satisfied), at the best price offered.

All the Estate and Interest (if any) of Robert Gerrand McClure, garage proprietor, of Flat 1, 5 Aquila Court, North Ballarat:

Firstly—As proprietor of an estate in fee simple in the land described in Certificate of Title Volume 8087 Folio 236 which is vacant land in St. Georges Street, Stawell, commencing northern boundary 230½ links approximately south of Main Street, having a frontage of 19½ links and a depth of 100 links. Registered Caveat No. F859349 affects the said estate and interest.

Secondly—As proprietor of an estate in fee simple in the land described in Certificate of Title Volume 8652 Folio 591 which is vacant land in Main Street, Stawell. The western boundary of the land commences approximately 188 feet east of Manse Street, Stawell, and has a frontage of 37 feet 9 inches, a western depth of 36 feet, and eastern boundary of 44 feet 8 inches and a rear boundary of 32 feet 7½ inches.

Thirdly—As proprietor as a tenant in common in equal shares with Eric Dalkin McClure in the land in Certificate of Title Volume 6597 Folio 345 which is vacant land in Madden Street, Stawell. Its boundary commences 190 links south of Florence Street and has a frontage of 54 links a depth of 106 links and a rear of 62 links.

Terms—Cash only. Property to be sold to the highest bidder—no reserve set.

7012

P. DUNCAN, Deputy Sheriff

In the Supreme Court of the State of Victoria
SALE BY THE SHERIFF

On Wednesday 25 June 1980 at 10.30 a.m. at the Police Station, Noble Park (unless process be stayed or satisfied).

All the Estate and Interest (if any) of Vasilios Margaritis, machine operator and Angela Margaritis (shown on Certificate of Title as Evangelia Margaritis, machinist) both of 4 Mackie Road, Mulgrave as joint proprietors of an estate in fee simple in the land described in Certificate of Title Volume 8431 Folio 891 upon which is erected a dwelling house known as No. 4 Mackie Road, Mulgrave.

Registered Mortgage Nos. G87023, H308923 and Caveat Nos. G563130 and H424809 affect the said estate and interest.

Terms—Cash only
7013

T. M. NICHOLLS, Sheriff's Officer

In the Supreme Court of the State of Victoria
SALE BY THE SHERIFF

On Tuesday 17 June 1980 at 10.30 a.m. at the Police Station, Doncaster (unless process be stayed or satisfied).

All the Estate and Interest (if any) of Douglas Gordon Johnston, Company Director, of 7 Silverdale Court, Doncaster as joint proprietor with Glenice Marie Johnston, married woman of an estate in fee simple in the land described in Certificate of Title Volume 8693 Folio 840 upon which is erected a brick veneer house known as No. 7 Silverdale Court, Doncaster.

Registered Mortgage Nos. E614048 and H175217 and Caveat No. H297199 affect the said estate and interest.

Terms—Cash only. Property to be sold to the highest bidder—no reserve set.

7014

H. BUETTNER, Sheriff's Officer

INSOLVENCY NOTICES

Bankruptcy Act 1966 (As Amended), Part X.
SUZANNE JOY GEMMILL

NOTICE OF MEETING, No. 106 OF 1980

Notice is hereby given that the abovenamed debtor signed an Authority under section 188 (1) of the *Bankruptcy Act 1966 As Amended* authorising Neville Bird to take over control of her property and further take notice that a meeting of creditors will be held at The Victorian Chamber of Manufactures, Room 1, 370 St. Kilda Road, Melbourne, 3004, on Friday, 23 May 1980 at 10.30 a.m.

Dated 29 April 1980

NEVILLE BIRD, Controlling Trustee
 Neville Bird, chartered accountant, 3 Bowen Crescent,
 Melbourne, 3004. Telephone 267 5111 7010

Bankruptcy Act 1966 (As Amended), Part X.
IAN LESLIE GEMMILL

NOTICE OF MEETING, No. 105 OF 1980

Notice is hereby given that the abovenamed debtor signed an Authority under section 188 (1) of the *Bankruptcy Act 1966 As Amended* authorising Neville Bird to take over control of his property and further take notice that a meeting of creditors will be held at The Victorian Chamber of Manufactures, Room 1, 370 St. Kilda Road, Melbourne, 3004, on Friday, 23 May 1980 at 10.30 a.m.

Dated 29 April 1980

NEVILLE BIRD, Controlling Trustee
 Neville Bird, chartered accountant, 3 Bowen Crescent,
 Melbourne, 3004. Telephone 267 5111 7011

NOTICE OF MAKING OF STATUTORY RULES

In pursuance of the provisions of the *Subordinate Legislation Act 1962* and the Regulations made thereunder, notice is given of the making of the following Statutory Rules:—

No.	Local Government Act 1958	Price
161/1980.	Local Government (Arbitrator) (Fees) Rules 1980	10c
	<i>Groundwater Act 1969</i>	
162/1980.	Groundwater (Board and Committee Members' Attendance Fees) Regulations 1980	10c
	<i>Second-hand Dealers Act 1958</i>	
163/1980.	Second-hand Dealers (Exemption No. 7) Regulations 1980	10c
	<i>Coroners Act 1958</i>	
164/1980.	Coroners (Post-Mortem Fees and Expenses) (Amendment) Regulations 1980	10c

Copies of these Statutory Rules when printed may be purchased at the Sale of Publications Branch of the Government Printing Office, located at 7A Parliament Place, Melbourne, 3002. If ordered by mail, remittance should be addressed to "The Government Printer, Box 203, P.O., North Melbourne, 3051", and should include 50c delivery and handling fee.

The annual subscription rates for Statutory Rules for the year commencing 1 January 1980, payable in advance, are as follows:—

*Statutory Rules (other than Public Service Determinations), Pamphlet copies only	\$36.00
Public Service Determinations	\$25.00

*The Bound Volume of Statutory Rules is not included in the subscription rate.

F. D. ATKINSON
 Government Printer.

STATE ACTS, 1979

Copies of the following Acts of the Parliament of Victoria may be obtained at the Government Printing Office, Sale of Publications Branch, 7A Parliament Place, Melbourne, phone 651 2754 or 651 2759, or from any accredited agent, at the price set opposite to each.

A delivery and handling fee must be added to your remittance when ordering by mail as follows:—

Total Value of Acts Ordered	Delivery and Handling Fee
10c—\$2.00	0.50c
\$2.05—\$5.00	\$1.00
\$5.05—\$20.00	\$1.50
Above \$20.00	\$2.00

Bound Volumes of 1978 State Acts (\$21.00) and the Index to the Bound Volumes (\$9.00) are also available.

No.	Price
9251. Constitution (Governor's Pension)	\$0.10
9252. Joint Select Committee (Road Safety)	\$0.20
9253. Cattle Compensation	\$0.10
9254. Constitution (Local Government)	\$0.30
9255. Gas and Fuel Corporation (Borrowing Powers)	\$0.10
9256. Ombudsman (Co-operation)	\$0.10
9257. Geelong (Haines Homes) Land	\$0.20
9258. Motor Car (Breath Testing Stations) (Amendment)	\$0.10
9259. Geelong Waterworks and Sewerage (Trust)	\$0.30
9260. Bright (Land Exchange)	\$0.20
9261. Supply (1979-80, No. 1)	\$0.30
9262. Money Lenders (Fees)	\$0.10
9263. Exhibition (Amendment)	\$0.30
9264. Health (Cattle)	\$0.10
9265. Victorian Public Offices Corporation (Amendment)	\$0.10
9266. Community Welfare Services (Amendment)	\$0.10
9267. Margarine (Amendment)	\$0.10
9268. Youth, Sport and Recreation (State Youth Council)	\$0.10
9269. Racing (Restricted Trotting Meetings)	\$0.10
9270. State Electricity Commission (Morwell Land Compensation)	\$0.10
9271. Construction Safety	\$1.00
9272. Business Franchise (Petroleum Products)	\$0.40
9273. Albany-Wodonga Agreement (Amendment)	\$0.40
9274. City of Melbourne (Re-subdivision)	\$0.10
9275. Co-operation	\$0.40
9276. Cemeteries (Melbourne General Cemetery)	\$0.10
9277. Melbourne and Metropolitan Board of Works (Amendment)	\$0.30
9278. River Improvement (Trusts and Valuations)	\$0.10
9279. Instruments (Writs)	\$0.10
9280. Forests (Reserved Land)	\$0.10
9281. Trinity College	\$0.50
9282. Revocation and Excision of Crown Reservations	\$0.30
9283. Local Government (Amendment)	\$0.50
9284. Tattersall Consultations (Amendment)	\$0.10
9285. Prahran Market	\$0.10
9286. Geelong Regional Commission (Amendment)	\$0.10
9287. Pharmacists (Amendment)	\$0.10
9288. Legal Profession Practice (Amendment)	\$0.10
9289. Barley Marketing (Amendment)	\$0.10
9290. Water Authorities (Constitution and Powers)	\$0.20
9291. Sewerage Authorities (Constitution and Powers)	\$0.30
9292. Wrongs (Defamation)	\$0.10
9293. Judges Salaries	\$0.10
9294. Poisons (Amendment)	\$0.10
9295. Business Franchise (Petroleum Products) (Licence Fees)	\$0.20
9296. State Electricity Commission (Amendment)	\$0.30
9297. Workers Compensation (Miscellaneous Provisions)	\$1.00
9298. Motor Car (Surcharge)	\$0.10
9299. Unclaimed Moneys	\$0.10
9300. Land Tax	\$0.10
9301. Business Franchise (Tobacco)	\$0.10

STATE ACTS, 1979—continued

No.	Price
9302. Public Authorities (Contributions) ..	\$0.10
9303. Appropriation (1979-80, No. 1) ..	\$3.50
9304. Gift Duty (Amendment) ..	\$0.10
9305. Pay-roll Tax ..	\$0.30
9306. Transport Works and Services ..	\$0.20
9307. Melbourne and Metropolitan Tramways (Borrowing Powers) ..	\$0.10
9308. County Court (Jurisdiction) ..	\$0.10
9309. State Forests Works and Services ..	\$0.10
9310. Young Men's Christian Association of Ballarat (Guarantee) ..	\$0.20
9311. Water Supply Works and Services ..	\$0.40
9312. Trustee Companies (Trustees Executors) ..	\$0.10
9313. Commercial Goods Vehicles (Aviation Fuel)	\$0.10
9314. Victorian Development Corporation (Powers)	\$0.20
9315. Town and Country Planning (Planning Schemes) ..	\$1.00
9316. Victorian Government Travel Authority (Reconstitution) ..	\$0.10
9317. Stamps (Amendment) ..	\$0.30
9318. Motor Car (Fees) ..	\$0.30
9319. Racing (Financial Provisions) ..	\$0.30
9320. Urban Land Authority ..	\$0.50
9321. Public Works and Services ..	\$0.30
9322. Second-hand Dealers (Closing Hours) ..	\$0.10
9323. Crimes (Amendment) ..	\$0.10
9324. Transfer of Land (Amendment) ..	\$0.40
9325. Melbourne College of Divinity ..	\$0.30
9326. Transport Regulation (Car Pools) ..	\$0.10
9327. Fisheries (Amendment) ..	\$0.10
9328. Egg Industry Stabilization (Amendment) ..	\$0.10
9329. Local Authorities Superannuation ..	\$0.30
9330. Latrobe Valley (Amendment) ..	\$0.10
9331. Liquor Control (Amendment) ..	\$0.10
9332. Motor Accidents (Amendment) ..	\$0.40
9333. Young Farmers' Finance Council ..	\$0.30
9334. Probate Duty ..	\$0.20
9335. Railways (Board) ..	\$0.10
9336. Ministry of Transport (Amendment) ..	\$0.10
9337. Abattoir and Meat Inspection (Amendment)	\$0.20
9338. Public Service (Amendment) ..	\$0.20
9339. Trustee Companies (Amendment) ..	\$0.20
9340. Vermin and Noxious Weeds (Amendment)	\$0.30
9341. Canned Fruits Marketing ..	\$0.40
9342. Marine (Amendment) ..	\$0.40
9343. Shire of Omeo (Tourist Gold Mine) ..	\$0.30
9344. Presbyterian Trusts ..	\$0.90
9345. Railway Construction and Property Board	\$0.90
9346. Motor Car (Insurance by Pensioners) ..	\$0.10
9347. Town and Country Planning (Amendment of Schemes) ..	\$0.10
9348. Labour and Industry (Amendment) ..	\$0.20
9349. Magistrates' Courts (Civil Jurisdiction) ..	\$0.40
9350. Master Builders' Association of Victoria (Guarantee) ..	\$0.20
9351. Education (Amendment) ..	\$0.20
9352. Educational Grants (Continuation) ..	\$0.10
9353. Wrongs (Assessment of Damages) ..	\$0.10
9354. Victorian Arts Centre ..	\$0.40
9355. Building Industry Long Service Leave (Amendment) ..	\$0.50
9356. Local Government (Land Liable to Flooding)	\$0.30
9357. Parliamentary Committees (Public Accounts and Expenditure Review Committee) ..	\$0.20
9358. Superannuation (Amendment) ..	\$0.30
9359. Health (Proprietary Medicines) ..	\$0.20
9360. Victorian Fishing Industry Council ..	\$0.30
9361. Grain Handling Improvement Authorities ..	\$0.30
9362. Wheat Marketing ..	\$0.80
9363. State Employees Retirement Benefits ..	\$1.00
9364. Town and Country Planning (General Amendment) ..	\$1.00
9365. Industrial Relations ..	\$1.40

STATE ACTS, 1980

Copies of the following Acts of the Parliament of Victoria may be obtained at the Government Printing Office, Sale of Publications Branch, 7A Parliament Place, Melbourne, phone 651 2754 or 651 2759, or from any accredited agent, at the price set opposite to each.

A delivery and handling fee must be added to your remittance when ordering by mail as follows:

Total Value of Acts Ordered	Delivery and Handling Fee
10c-\$2.00	0.50c
\$2.05-\$5.00	\$1.00
\$5.05-\$20.00	\$1.50
Above \$20.00	\$2.00

Bound Volumes of 1978 State Acts (\$21.00) and the Index to the Bound Volumes (\$9.00) are also available.

No.	Price
9366. Constitutional Powers (Coastal Waters)	20c
9367. Parliamentary Committees (Public Bodies Review)	40c

PUBLICATION OF OFFICIAL MATTER

Attention is invited to the following procedure in relation to the publication of official matter in the *Government Gazette*:—

Publication will be facilitated by the submission of carbon copies for the use of the Gazette Officer.

1. Matter submitted to the Executive Council

Matter submitted to the Executive Council which requires gazettal will normally be published in the issue of the following week.

Where urgent gazettal is required, special arrangements should be made with the Gazette Officer, Room 15, first floor, Old Treasury Building.

2. Other matter

(a) All other matter duly certified by a responsible officer for publication should be lodged with the Gazette Officer not later than half-past Nine a.m. on Tuesday.

(b) Lengthy or involved notices should be forwarded several days before publication.

(c) Proofs, which will be supplied only when specifically requested or at the direction of the Gazette Officer, should be returned promptly to avoid delay in publication.

(d) No additions or amendments to matters for publication will be accepted by telephone.

THE "VICTORIA GOVERNMENT GAZETTE"

PUBLICATION—A VICTORIA GOVERNMENT GAZETTE is published every WEDNESDAY EVENING unless advertised otherwise.

SUBSCRIPTIONS—The Subscription, including postage, is \$62 per annum, or \$31 per half year, payable in advance. Subscriptions are required for whole months, but must cover at least a half-year.

PRIVATE ADVERTISEMENTS—Advertisements will be received by the Government Printer not later than the day preceding publication—at ordinary rates at or before ONE p.m. and at double rates between ONE p.m. and HALF PAST THREE p.m. The charge for ADVERTISEMENTS is 78 cents per line single column and \$1.56 per line double column. The charge for a full page is \$118. The title forms one or more lines as a heading. On an average ten words make a line of single column. Every signature must likewise be counted as a line. The final words of a paragraph though only portion of a line, must be counted as one line. Signatures (in particular) and proper names must be written very clearly in the text: ONE SIDE ONLY of each sheet of paper should be written upon.

All documents NOT CLEARLY PREPARED will be returned unpublished. Where brands occur, not provided for by the ordinary letters of the alphabet, a written explanatory description also must be furnished.

PAYMENTS—Unless the advertiser has a Credit Account, all payments are required in advance. Remittances should be made by cheque, postal order or money order, payable to "GOVERNMENT PRINTER".

CORRESPONDENCE—All correspondence should be addressed to "The Victorian Government Printer, P.O. Box 203, North Melbourne, 3051".

PURDIE, J., & CO., 138 Moorabool Street, Geelong, Victoria 3220.

SALE AUTHORIZED NEWSAGENCY 292-294 Raymond Street, Sale, Victoria 3850.

VERNONS OF RICHMOND, 261 Bridge Road, Richmond, Victoria 3121.

VIEW POINT AUTHORIZED NEWSAGENCY, 4 View-Point, Bendigo, Victoria 3550.

AGENTS FOR THE "VICTORIA GOVERNMENT GAZETTE"

The following have been appointed agents to receive Advertisements and Subscriptions for the Victoria Government Gazette:—

ARMSTRONG'S AGENCY, 217 Queen Street, Melbourne, Victoria 3000.

ARNALL & JACKSON, 390 Barkly Street, Brunswick, Victoria 3056

BAIRNSDALE AUTHORIZED NEWSAGENCY, 132 Main Street, Bairnsdale, Victoria 3875.

BENALLA AUTHORIZED NEWSAGENCY, 45 Bridge Street, Benalla, Victoria 3672.

BLANE'S AUTHORIZED NEWSAGENTS, 162 Murray Street, Colac, Victoria 3250.

CARTER, R. G., ADVERTISING SERVICE PTY. LTD., 129 Church Street, Hawthorn, Victoria 3122.

CORNELL, R. G., 126 Eighth Street, Mildura.

FAROE, S. W. & E. P., 79 Henty Street, Casterton, Victoria 3311.

FRANKS, H., & CO., 184 Ryrie Street, Geelong, Victoria 3220.

GORDON & GOTCH AUSTRALASIA LTD., 25-37 Huntingdale Road, Burwood, Victoria 3125.

HARSTON, PARTRIDGE & CO. PTY. LTD., 455 Little Collins Street, Melbourne, Victoria 3000.

KYNETON GUARDIAN PTY. LTD., P.O. Box 18, Kyneton, Victoria 3444.

LONSDALE NEWSAGENCY, 250 Lonsdale Street, Dandenong, Victoria 3175.

LOVELL'S SHEPPARTON NEWSAGENCY, 246 Wyndham Street, Shepparton, Victoria 3630.

THE MERCANTILE EXCHANGE, 15 Queen Street, Melbourne, Victoria 3000.

MCDONALD'S NEWSAGENCY, 88 Bridge Street, Ballarat, Victoria 3350.

MCGILL'S AUTHORIZED NEWSAGENCY, 183-5 Elizabeth Street, Melbourne, Victoria 3000.

McNAUGHTON, P. R. & L. A., 112-114 Gray Street, Hamilton, Victoria 3300.

POWNEY'S AUTHORIZED NEWSAGENCY, 293 Hargreaves Street, Bendigo, Victoria 3550.

CONTENTS

	Page
Acts of Parliament	1465
Acts of Parliament on Sale at the Government Printing Office	1526
Appointments	1482
Cemeteries—Scale of Fees	1479
Contracts	1477
Estates of Deceased Persons	1481
Government Notices	1468
Insolvency Notices	1526
Lands	1499
Minerals and Energy	1478
Notice to Mariners	1473
Notice of Making of Statutory Rules	1526
Orders in Council—	
Acts—Water; Crown Land (Reserves); Road Traffic; Local Government; Crown Land (Reserves); Land; Superannuation; Historic Buildings; State Electricity Commission; Water; Sewerage Districts; Local Government; Latrobe Valley Water and Sewerage; Sewerage Districts; Racing; Fruit and Vegetables; Coal Mines.	1483 et seq
Police Sale	1476
Private Advertisements	1502
Proclamations	1465
Resignations	1483
Tenders	1501
Transport Regulation Board—Public Hearings	1470