



# Victoria Government Gazette

No. 38—Wednesday, 28 May 1980

## PROCLAMATIONS

### ACTS OF PARLIAMENT

#### PROCLAMATION

By His Excellency the Governor of the State of Victoria and its Dependencies in the Commonwealth of Australia, &c., &c., &c.

I, the Governor of the State of Victoria, in the Commonwealth of Australia, do hereby declare that I have this day assented, in Her Majesty's name, to the Bills passed by the Parliament of the said State, the titles whereof are hereunder set forth, together with the short titles, that is to say:—

No. 9426. "An Act to make further provision with respect to certain enactments of the Parliament of England and of the Parliament of Great Britain and of the Parliament of the United Kingdom of Great Britain and Ireland in force at the time of the passing of the Act 9 George IV. c. LXXXIII., to incorporate into the Statute Law of Victoria certain of such enactments, to amend the *Imperial Acts Application Act 1922* and for other purposes." (*Imperial Acts Application Act 1980.*)

No. 9427. "An Act to revise Statute Law." (*Statute Law Revision Act 1980.*)

No. 9428. "An Act to re-enact with Amendments the Law relating to Estate Agents and Sub-agents." (*Estate Agents Act 1980.*)

Given under my Hand and the Seal of the State of Victoria aforesaid, at Melbourne, this twenty-seventh day of May, in the year of our Lord One thousand nine hundred and eighty and in the twenty-ninth year of the reign of Her Majesty Queen Elizabeth II.

(L.S.) HENRY WINNEKE

By His Excellency's Command

R. J. HAMER  
Premier

GOD SAVE THE QUEEN!

No. 9462. Shall come into operation on a day to be fixed by Proclamation.

No. 9427. Subject to section 6 (2), this Act shall come into operation on the day on which it receives the Royal Assent.

No. 9428. Several provisions of this Act shall come into operation on a day or on the respective days to be fixed by proclamation or successive proclamations.

No. 38—21570/80—Price 50 cents, delivered \$1. Subscription rate: Half-yearly \$31; Yearly \$62.

### Land Act 1958 ROAD PROCLAIMED

#### PROCLAMATION

By His Excellency the Governor of the State of Victoria and its Dependencies in the Commonwealth of Australia, &c., &c., &c.

I, the Governor of the State of Victoria, in the Commonwealth of Australia, by and with the advice of the Executive Council of the said State, pursuant to the provisions of section 25 (3) (c) of the *Land Act 1958*, do hereby proclaim as road the Crown land hereinafter described, viz.:

Parish of Clunes, being the land indicated by hatching on plan hereunder—(C.395(L7) (G.76606).

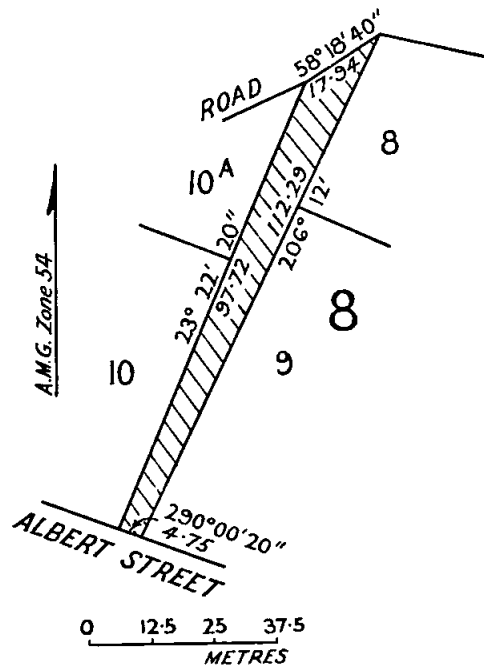

Given under my Hand and the Seal of the State of Victoria aforesaid, at Melbourne, this twentieth day of May, in the year of our Lord One thousand nine hundred and eighty, and in the twenty-ninth year of the reign of Her Majesty Elizabeth the Second, Queen of Australia.

(L.S.) HENRY WINNEKE

By His Excellency's Command

W. V. HOUGHTON  
Minister of Lands

GOD SAVE THE QUEEN!

Land Act 1958  
LAND DECLARED UNDER SECTION 22c OF THE  
LAND ACT 1958

PROCLAMATION

By His Excellency the Governor of the State of Victoria and its Dependencies in the Commonwealth of Australia, &c., &c., &c.

I, the Governor of the State of Victoria, in the Commonwealth of Australia, by and with the advice of the Executive Council of the said State, pursuant to the provisions of section 22c (2) of the Land Act 1958, and upon receipt of certification by the clerk of the municipality concerned (Shire of Heytesbury) to the effect that the land constitutes land which is or has been used for recreational purposes, do by this Proclamation declare to be land to which section 22c of the said Act applies all that piece of land being Crown allotment 47A, Parish of Brucknell, and being the whole of the land more particularly described in Crown Grant Volume 6022 Folio 252—(L.1-450).

Given under my Hand and the Seal of the State of Victoria aforesaid, at Melbourne, this twentieth day of May, in the year of our Lord One thousand nine hundred and eighty, and in the twenty-ninth year of the reign of Her Majesty Elizabeth the Second, Queen of Australia.

(L.S.) HENRY WINNEKE

By His Excellency's Command

W. V. HOUGHTON  
Minister of Lands

GOD SAVE THE QUEEN!

Land Act 1958  
LAND DECLARED UNDER SECTION 22c OF THE  
LAND ACT 1958

PROCLAMATION

By His Excellency the Governor of the State of Victoria and its Dependencies in the Commonwealth of Australia, &c., &c., &c.

I, the Governor of the State of Victoria, in the Commonwealth of Australia, by and with the advice of the Executive Council of the said State, pursuant to the provisions of section 22c (2) of the Land Act 1958, and upon receipt of certification by the clerk of the municipality concerned (Shire of Heytesbury) to the effect that the land constitutes land which is or has been used for recreational and sporting purposes, do by this Proclamation declare to be land to which section 22c of the said Act applies all that piece of land being part of Crown allotment 47, Parish of Brucknell, and being the whole of the land more particularly described in Certificate of Title Volume 9297 Folio 672—(L.1-447).

Given under my Hand and the Seal of the State of Victoria aforesaid, at Melbourne, this twentieth day of May, in the year of our Lord One thousand nine hundred and eighty, and in the twenty-ninth year of the reign of Her Majesty Elizabeth the Second, Queen of Australia.

(L.S.) HENRY WINNEKE

By His Excellency's Command

W. V. HOUGHTON  
Minister of Lands

GOD SAVE THE QUEEN!

PUBLIC HIGHWAY—CITY OF BOX HILL

PROCLAMATION

By His Excellency the Governor of the State of Victoria and its Dependencies in the Commonwealth of Australia, &c., &c., &c.

Whereas by the Local Government Act 1958, section 519 it is amongst other things enacted that it shall be lawful for the Governor in Council at any time and from

time to time upon the request of the council of any municipality by notice in the Government Gazette to proclaim any land reserved used or by purchase used or exchange acquired for a street, road, highway, thoroughfare, bridge, square, court, alley, or right-of-way or any street, road, lane or passage made or laid out or proposed to be made or laid out on any land of which a plan of subdivision delineating that street, road, lane or passage has been sealed with the seal of the municipality under subdivision (3) of Division 9 of Part XIX. of the Local Government Act 1958 or a corresponding previous enactment to be a public highway and that land shall thereupon and thenceforth from the date of such Proclamation become and be absolutely dedicated to the public as a public highway within the meaning of any law then or thereafter in force.

And whereas the Council of the City of Box Hill has requested that the land hereinafter mentioned, reserved for a street be so declared to be a public highway.

Now therefore, I, the Governor of the State of Victoria in the Commonwealth of Australia by and with the advice of the Executive Council of the said State, do by this Proclamation declare that the land off Kitchener Street, Box Hill, shown by hatching on the plan hereunder shall be a public highway within the meaning of the said Act.

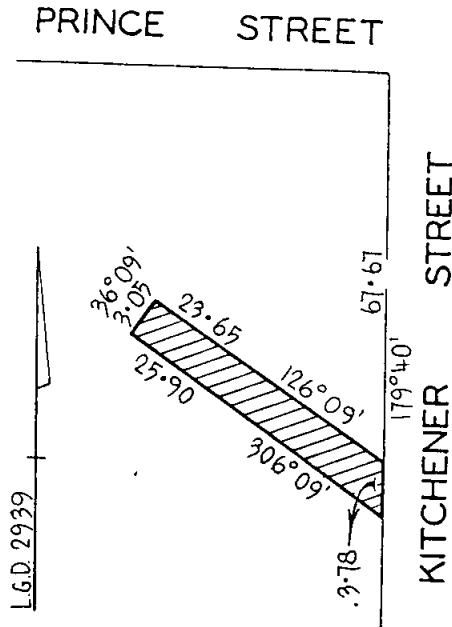

LENGTHS ARE IN METRES.

Given under my Hand and the Seal of the State of Victoria aforesaid, at Melbourne, this twentieth day of May, in the year of our Lord One thousand nine hundred and eighty, and in the twenty-ninth year of the reign of Her Majesty Queen Elizabeth II.

(L.S.) HENRY WINNEKE

By His Excellency's Command

D. G. CROZIER  
Minister for Local Government

GOD SAVE THE QUEEN!

**POLICE REGULATION (RETIRED POLICE RESERVE)**  
**ACT 1980, No. 9392**  
**DATE OF COMING INTO OPERATION**

**PROCLAMATION**

By His Excellency the Governor of the State of Victoria and its Dependencies in the Commonwealth of Australia, &c., &c., &c.

Whereas by an Act of Parliament of the State of Victoria passed in the twenty-ninth year of the reign of Her Majesty Elizabeth the Second, Queen of Australia, entitled the *Police Regulation (Retired Police Reserve) Act 1980 No. 9392* it is amongst other things enacted that the several provisions of the said Act shall come into operation on a day or on the respective days to be fixed by proclamation or successive proclamations of the Governor in Council published in the *Government Gazette*:

Now therefore I the Governor of the State of Victoria, in the Commonwealth of Australia, by and with the advice of the Executive Council of the said State, do by this my proclamation fix Tuesday, the twentieth day of May, One thousand nine hundred and eighty as the day on which all the provisions of the said *Police Regulation (Retired Police Reserve) Act 1980 No. 9392* shall come into operation.

Given under my Hand and the Seal of the State of Victoria aforesaid, at Melbourne, this twentieth day of May in the year of our Lord One thousand nine hundred and eighty, and in the twenty-ninth year of the reign of Her Majesty Elizabeth the Second, Queen of Australia.

(L.S.) HENRY WINNEKE

By His Excellency's Command  
 L. H. S. THOMPSON  
 Minister for Police and Emergency Services

GOD SAVE THE QUEEN!

**GOVERNMENT NOTICES**

**PUBLIC HOLIDAY—QUEEN'S BIRTHDAY**

It is hereby notified that on—  
 MONDAY, 16 JUNE 1980

the Public Offices will be closed, such day having been appointed under the provisions of the *Public Service Act 1974*, to be observed as a holiday in the Public Offices throughout the State of Victoria.

This notice relates only to the closing of the State Public Offices. All inquiries regarding the holiday in other offices and in shops and industry should be directed to the Department of Labour and Industry, Industrial Information Service, 500 Bourke Street, Melbourne, 3000. (Telephone 651 3911.)

R. J. HAMER  
 Premier

Department of the Premier  
 Melbourne, 26 May 1980

*Local Government Act 1958*

**NOTICE OF CONFIRMATION OF AN ORDER OF THE COUNCIL OF THE CITY OF MELBOURNE ADOPTING A PROPOSAL FOR THE CLOSURE OF MCCONNELL STREET, KENSINGTON, TO THROUGH TRAFFIC**

Pursuant to the provisions of section 539c of the *Local Government Act 1958*, the Governor in Council, on 20 May 1980 confirmed an Order of the Council of the City of Melbourne made on 19 November 1979, adopting a proposal for the closure of McConnell Street, Kensington, to through traffic by the erection of a barrier at the location shown on the plan hereunder.

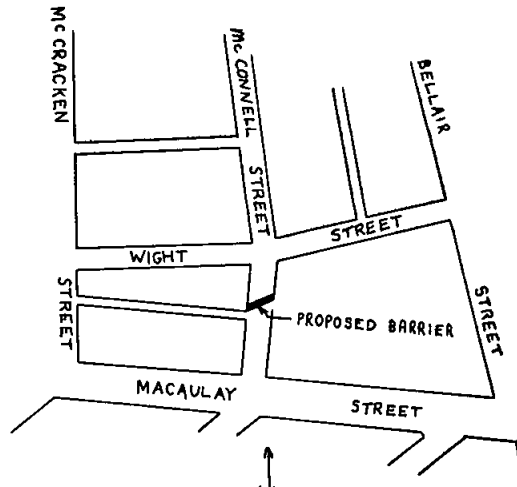

TOM FORRISTAL  
 Clerk of the Executive Council

At the Executive Council Chamber  
 Melbourne, 20 May 1980

*Local Government Act 1958*

**NOTICE OF CONFIRMATION OF AN ORDER OF THE COUNCIL OF THE CITY OF MELBOURNE ADOPTING A PROPOSAL FOR THE CLOSURE OF MURPHY STREET, NORTH MELBOURNE, TO THROUGH TRAFFIC**

Pursuant to the provisions of section 539c of the *Local Government Act 1958*, the Governor in Council, on 20 May 1980 confirmed an Order of the Council of the City of Melbourne made on 19 November 1979, adopting a proposal for the closure of Murphy Street, North Melbourne, to through traffic by the erection of a barrier at the location shown on the plan hereunder.

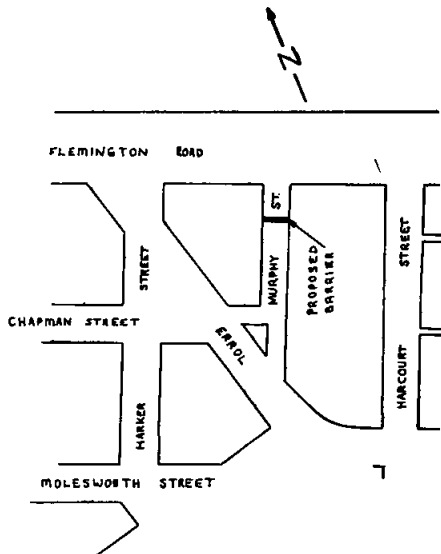

TOM FORRISTAL  
 Clerk of the Executive Council

At the Executive Council Chamber  
 Melbourne, 20 May 1980

Local Government Act 1958

NOTICE OF CONFIRMATION OF AN ORDER OF THE COUNCIL OF THE SHIRE OF BACCHUS MARSH ADOPTING A PROPOSAL FOR THE CLOSURE OF A STREET TO THROUGH TRAFFIC

Pursuant to the provisions of section 539c of the Local Government Act 1958, the Governor in Council, on 20 May 1980 confirmed an Order of the Council of the Shire of Bacchus Marsh made on 15 November 1979 adopting a proposal for the closure of Wellington Street, Bacchus Marsh to through traffic by the erection of a barrier at the location shown on the plan hereunder (79/3087).

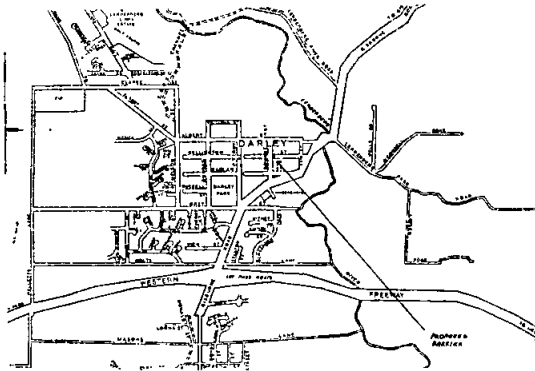

TOM FORRISTAL  
Clerk of the Executive Council

At the Executive Council Chamber  
Melbourne, 20 May 1980

Local Government Act 1958

NOTICE OF CONFIRMATION OF AN ORDER OF THE COUNCIL OF THE CITY OF PRAHRAN ADOPTING A PROPOSAL FOR THE CLOSURE OF FITZGERALD STREET, SOUTH YARRA TO THROUGH TRAFFIC

Pursuant to the provisions of section 539c of the Local Government Act 1958, the Governor in Council, on 27 May 1980 confirmed an Order of the Council of the City of Prahran made on 26 November 1979 adopting a proposal for the closure of Fitzgerald Street, South Yarra to through traffic by the erection of barriers in Fitzgerald Street where indicated on the plan hereunder.

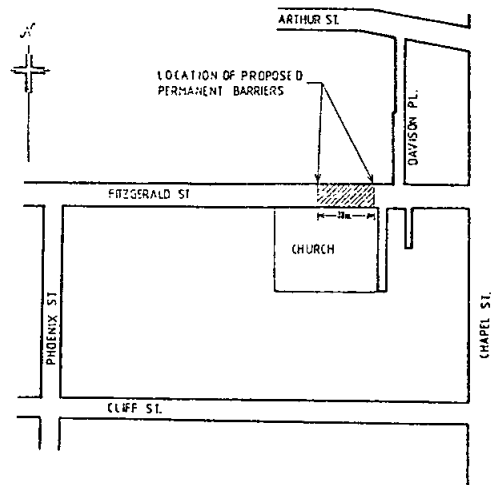

TOM FORRISTAL  
Clerk of the Executive Council

Local Government Act 1958

NOTICE OF CONFIRMATION OF AN ORDER OF THE COUNCIL OF THE CITY OF CAULFIELD ADOPTING A PROPOSAL FOR THE CLOSURE OF QUEENS AVENUE, CAULFIELD TO THROUGH TRAFFIC

Pursuant to the provisions of section 539c of the Local Government Act 1958, the Governor in Council, on 20 May 1980 confirmed an Order of the Council of the City of Caulfield made on 24 July 1979 adopting a proposal for the closure of Queens Avenue, Caulfield, to through traffic by the erection of a barrier at the location shown on the plan hereunder.

CITY OF CAULFIELD

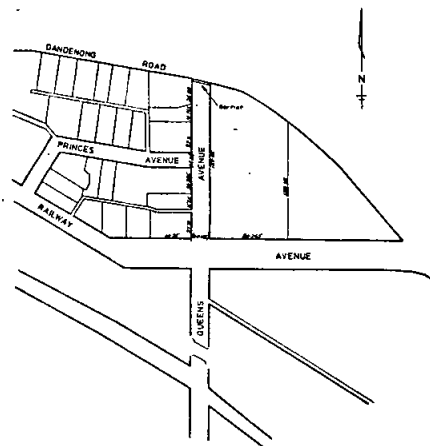

TOM FORRISTAL  
Clerk of the Executive Council

At the Executive Council Chamber  
Melbourne, 20 May 1980

Local Government Act 1958

NOTICE OF CONFIRMATION OF AN ORDER OF THE COUNCIL OF THE SHIRE OF BELLARINE ADOPTING A PROPOSAL FOR THE CLOSURE OF A ROAD TO THROUGH TRAFFIC

Pursuant to the provisions of section 539c of the Local Government Act 1958, the Governor in Council on 20 May 1980 confirmed an Order of the Council of the Shire of Bellarine made on 17 December 1979 adopting a proposal for the closure of Alcoa Road, Moolap, to through traffic by the erection of barriers at the locations shown on the plan hereunder—(80/0288).

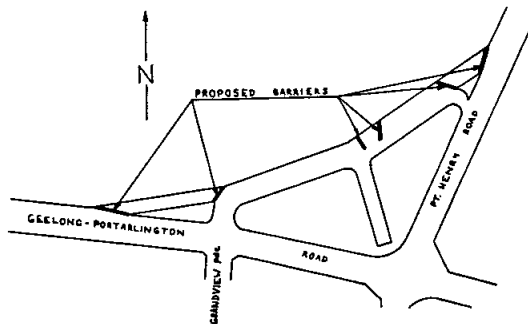

TOM FORRISTAL  
Clerk of the Executive Council

At the Executive Council Chamber  
Melbourne, 20 May 1980

*Local Government Act 1958*

**NOTICE OF CONFIRMATION OF AN ORDER OF THE COUNCIL OF THE CITY OF MELBOURNE ADOPTING A PROPOSAL FOR THE CLOSURE OF A STREET TO THROUGH TRAFFIC**

Pursuant to the provisions of section 539c of the *Local Government Act 1958*, the Governor in Council, on 20 May 1980 confirmed an Order of the Council of the City of Melbourne made on 19 November 1979, adopting a proposal for the closure of Newry Street at the west side of Station Street, North Carlton to through traffic by the erection of a barrier at the location shown on the plan hereunder—(80/0228).

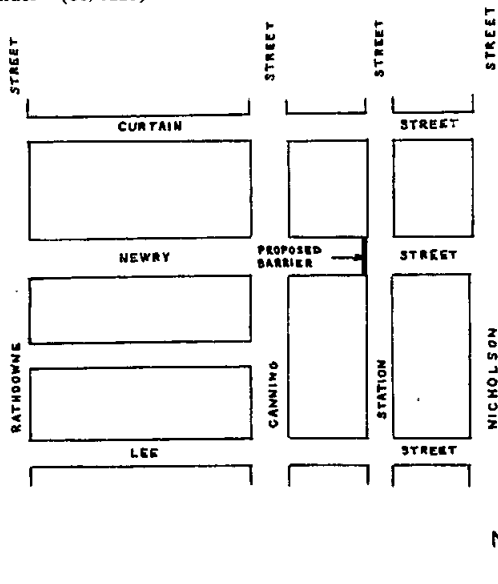

**TOM FORRISTAL**  
Clerk of the Executive Council

At the Executive Council Chamber  
Melbourne, 20 May 1980

south side of Curtain Street, North Carlton to through traffic by the erection of barriers at the locations shown on the plan hereunder—(80/0229).

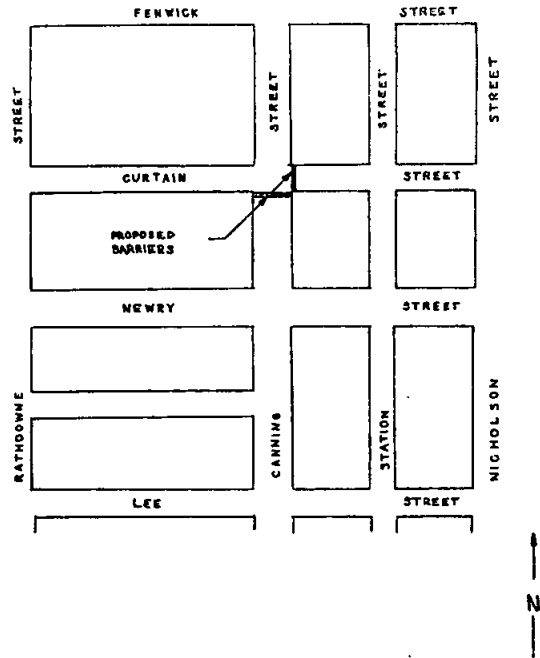

**TOM FORRISTAL**  
Clerk of the Executive Council

At the Executive Council Chamber  
Melbourne, 20 May 1980

*Local Government Act 1958*

**NOTICE OF CONFIRMATION OF AN ORDER OF THE COUNCIL OF THE CITY OF MELBOURNE ADOPTING A PROPOSAL FOR THE CLOSURE OF ANTHONY STREET, KENSINGTON, TO THROUGH TRAFFIC**

Pursuant to the provisions of section 539c of the *Local Government Act 1958*, the Governor in Council, on 20 May 1980 confirmed an Order of the Council of the City of Melbourne made on 29 October 1979 adopting a proposal for the closure of Anthony Street, Kensington, to through traffic by the erection of a barrier in Anthony Street at its intersection with McCracken Street.

**TOM FORRISTAL**  
Clerk of the Executive Council

At the Executive Council Chamber  
Melbourne, 20 May 1980

**DANDENONG VALLEY REGIONAL LIBRARY SERVICE**

**NOTICE OF APPROVAL OF AGREEMENT**

The agreement made between the Mayor, Councillors and Citizens of the City of Berwick, the Mayor, Councillors and Citizens of the City of Dandenong, the Mayor, Councillors and Citizens of the City of Springvale, the President, Councillors and Ratepayers of the Shire of Cranbourne and the President, Councillors and Ratepayers of the Shire of Pakenham for the provision of a joint library service in the municipal districts of the said municipalities was approved by the Governor in Council pursuant to the provisions of section 799 of the *Local Government Act 1958* on 20 May 1980.

**TOM FORRISTAL**  
Clerk of the Executive Council

At the Executive Council Chamber  
Melbourne, 20 May 1980

*Local Government Act 1958*

**NOTICE OF CONFIRMATION OF AN ORDER OF THE COUNCIL OF THE CITY OF MELBOURNE ADOPTING A PROPOSAL FOR THE CLOSURE OF STREETS TO THROUGH TRAFFIC**

Pursuant to the provisions of section 539c of the *Local Government Act 1958*, the Governor in Council, on 20 May 1980 confirmed an Order of the Council of the City of Melbourne made on 19 November 1979, adopting a proposal for the closure of Curtain Street at the east side of Canning Street, North Carlton and Canning Street at the

*Local Government Act 1958*

**NOTICE OF CONFIRMATION OF AN ORDER OF THE COUNCIL OF THE CITY OF MELBOURNE ADOPTING A PROPOSAL FOR THE CLOSURE OF ARDEN AND SOUTHEY STREETS, KENSINGTON, TO THROUGH TRAFFIC**

Pursuant to the provisions of section 539c of the *Local Government Act 1958*, the Governor in Council, on 20 May 1980 confirmed an Order of the Council of the City of

Melbourne made on 29 October 1979, adopting a proposal for the closure of Arden and Southey Streets, Kensington, to through traffic by the erection of barriers at the locations shown on the plan hereunder.

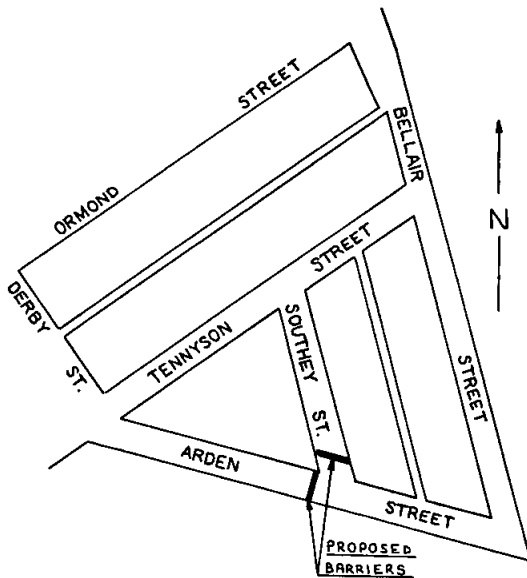

TOM FORRISTAL  
Clerk of the Executive Council

At the Executive Council Chamber  
Melbourne, 20 May 1980

**COMPANIES ACT 1961, SECTION 80**

I, Haddon Storey, Minister administering the Companies Act 1961, hereby exempt, pursuant to section 80 (1A) of the Act, Alycidon Syndications Limited (hereinafter called "the company") from complying with the provisions of paragraph (b) (iii) of sub-section (1) of section 80 of the Act in relation to interests in the syndicates referred to in the Schedule hereto, to be created by the company pursuant to four Deeds of Trust, each dated 13 March 1980 and between the company, Eagle Star Nominees Limited, Eagle Star Insurance Company Limited, Australian Eagle Insurance Company Limited and Eagle Star Holdings Limited.

**SCHEDULE**

1. Ascot Syndicate
2. Sovereign Syndicate
3. Guineas Syndicate
4. Epsom Syndicate

Signed at Melbourne, 14 May 1980

HADDON STOREY  
Attorney-General

**Public Service Act 1974**

**NOTIFICATION UNDER SECTION 60 (5)**

A communication from me to Reginald Arthur Loughrey an officer of the Ministry for Police and Emergency Services was posted to his last known address on 21 May 1980.

R. L. KING  
Secretary

**PUBLIC TRUSTEE ACT 1958, SECTION 17**

I hereby give notice that on 13 May 1980, the Public Trustee filed elections to administer the following deceased persons' estates in accordance with section 17 of the Public Trustee Act 1958.

BETLES, LIONEL ROBERT, formerly of 204 Seymour Street, Ballarat, but late of Queen Elizabeth Geriatric Centre, 102 Ascot Street, Ballarat, pensioner, died 10 October 1979.

BROMLEY, BERTRAM DAVID BLANDFORD, late of Ararat, retired butcher, died 11 March 1979.

HOWSE, HARRY FIELDING, also known as Henry Fielding Howse, late of Flat 12, 39 Byron Street, Elwood, salesman, died 12 February 1980.

SMITH, MARGREET MCGREGOR, also known as Margreete McGregor Smith, late of Flat 13, 1 Ireland Street, Burwood, married woman, died 28 January 1980.

TIERNEY, EVA MAY, formerly of 7 Herbert Street, North Carlton, but late of 102 Holden Street, North Fitzroy, widow, died 17 March 1980.

P. T. SPENCER  
Public Trustee

168 Exhibition Street, Melbourne, 3000, 21 May 1980

Creditors, next of kin, and others having claims against the estate of any of the under-mentioned deceased persons are required to send particulars of their claims to the Public Trustee, 168 Exhibition Street, Melbourne, Vic. 3000, the personal representative, on or before 4 August 1980 after which date the Public Trustee may convey or distribute the assets having regard only to the claims of which the Public Trustee then has notice:

ANN, NELLIE GERTRUDE, late of 7 Aldene Court, Hall Drive, Chilwell, Nottingham, England, widow, died 7 November 1979.

BETLES, LIONEL ROBERT, formerly of 204 Seymour Street, Ballarat, but late of Queen Elizabeth Geriatric Centre, 102 Ascot Street, Ballarat, pensioner, died 10 October 1979.

BLYTHMAN, EILEEN THELMA, late of 60 Mason Street, Newport, widow, died 20 March 1980.

BROMLEY, BERTRAM DAVID BLANDFORD, late of Ararat, retired butcher, died 11 March 1979.

CASEMORE, ERIC ELI, late of 21 Hambleton Road, Hawthorn, retired toolmaker, died 25 March 1980.

DUCKETT, MARGARET VERA, formerly of 11 Gleniffer Avenue, Moorabbin, but late of Centennial House, 313 Punt Road, Prahran, married woman, died 26 March 1980.

EATON, PATRICK KEMPTON, late of Ballarato Road, Skye, casual labourer, died 3 February 1980.

FRUDD, HELEN ELIZABETH, late of Kew, pensioner, died 27 December 1979.

HOWSE, HARRY FIELDING, also known as Henry Fielding Howse, late of Flat 12, 39 Byron Street, Elwood, salesman, died 12 February 1980.

LENNE, LORNA ETHELWYN, also known as Lorna Lenne, late of 8 Merville Avenue, Malvern East, widow, died 19 February 1980.

MERCOVICH, VERONICA LILLIAN, also known as Veronica Mercovich, late of 79 Mansfield Street, Thornbury, spinster, died 30 December 1979.

SMITH, MARGREET MCGREGOR, also known as Margreete McGregor Smith, late of Flat 13, 1 Ireland Street, Burwood, married woman, died 28 January 1980.

TIERNEY, EVA MAY, formerly of 7 Herbert Street, North Carlton, but late of 102 Holden Street, North Fitzroy, widow, died 17 March 1980.

VALINTINE, LINDSAY THOMAS HENRY, late of Palmerston North, New Zealand, company director, died 9 November 1979.

WHITNEY, JOSEPH ALPHONSUS, late of 48 Nicholas Street, Chilwell, retired motor company employee, died 13 December 1979.

Melbourne, 21 May 1980

P. T. SPENCER  
Public Trustee

Transport Regulation Act  
TRANSPORT REGULATION BOARD

## HEARING OF APPLICATIONS

Notice is hereby given that the following applications will be considered by the Transport Regulation Board on 17 June 1980.

BEER, N. W., Loch. Application to license one commercial passenger vehicle, to be purchased, to operate for the carriage of workers between Korumburra and Dandenong via the South Gippsland Highway, South Gippsland Freeway and Princes Highway.

NOTE—No pick up rights are sought between Five Ways and Dandenong.

## TIME-TABLE

	First Trip	Second Trip
Depart Korumburra	6.00 a.m.	2.00 p.m.
Arrive Dandenong	7.15 a.m.	3.15 p.m.
Depart Dandenong	4.45 p.m.	12.05 a.m.
Arrive Korumburra	6.00 p.m.	1.20 a.m.

Fares—To be determined.

NOTE—This application replaces a previous application which appeared in the *Victoria Government Gazette*, No. 17, dated 5 March 1980.

ANSETT TRANSPORT INDUSTRIES (OPERATIONS) PTY. LTD. (trading as Provincial Motors), Epsom. Application to license one commercial passenger vehicle to be purchased, with seating capacity for approximately ten persons to operate, free of charge, for the carriage of clients of Provincial Motors between their applicants' premises at Epsom and the Bendigo urban district.

FALLON, L. F. & J. P., Alexandra. Application to license one commercial passenger vehicle with seating capacity for eighteen persons to operate as a country special service omnibus from Alexandra.

FALLON, L. F. & J. P., Alexandra. Application to license four commercial passenger vehicles to operate as follows: (a) Under the same terms and conditions as existing licences T.S.1457, T.S.1458, T.S.1459 and T.S.1460 in the name of the applicants. (b) Under charter conditions from within a 20-km radius of Alexandra.

NOTE—This application is subject to the cancellation of the above-mentioned licences.

PETERSON, I. F., Omeo. Application to license a Toyota four-wheel drive vehicle with seating capacity for eleven persons to operate for the carriage of passengers on day tours from Omeo into the surrounding area as follows:

## SCHEDULE OF TOURS

*Tour 1—Omeo to Mitta Mitta River.* Depart Omeo, travel along Omeo Valley Road to Kelly's Road, then via Kelly's Road to Mitta Mitta River and return via same route to Omeo.

*Tour 2—Omeo to Cobungra.* Depart Omeo via Alpine Highway to Junction Plain Road then return via Junction Plain Road to Alpine Highway, then via Victoria Falls Road to falls, returning via Victoria Falls Road to Alpine Highway to McNamara's Road to High Forest Road, then via High Forest Road to Alpine Highway returning to Omeo.

*Tour 3—Omeo to Mt. Hotham.* Depart Omeo, travel via Alpine Highway to Mt. Hotham returning via same route to Omeo.

*Tour 4—Omeo to Limestone Creek and Caves.* Depart Omeo via Omeo Highway to Benambra Road then to Benambra then via Benambra/Limestone Road to Limestone Creek area, then return via same route to Omeo.

*Tour 5—Omeo to Blue Duck and Rocky Valley Dam, returning via Glen Wills.* Depart Omeo via Omeo Highway to Buckety Plains Road then via Buckety Plains Road to Rocky Valley Dam, returning

via Buckety Plains Road to Omeo Highway, then via Knocker Road to Omeo Valley Road, via Omeo Valley Road to Omeo.

Fares—To be determined.

NOTE—These rights were previously held by the applicant on licence No. T.O.20 which was cancelled on request on 22 January 1980.

ROBERTS, L. T., Noble Park. Application to license one commercial passenger vehicle with seating capacity for four persons to operate free of charge, in conjunction with another licensed vehicle operated by Mr T. R. McConnell, for the carriage of pre-school children between their homes and the Sandown Child Care Centre, Noble Park.

Application by the persons listed hereunder for one Metropolitan Taxi licence to be issued subject to the cancellation of each Suburban Taxi licence shown.

COOKE, F., Watsonia; S.T.6209.

DAISLEY, M. S., Lower Templestowe; S.T.5826.

ELIADES, C., Glenroy; S.T.5375.

HALEY, L. W., West Brunswick; S.T.5240.

KWASNEY, H. E., Ripponlea; S.T.7888.

MACALISTER, A. F., Flemington; S.T.7839.

PAPAKYRIAKOPOULOS, K., Fairfield; S.T.6270.

SANOS, E., East Ivanhoe; S.T.7871.

SKLIROS, P., Pascoe Vale; S.T.6231 and S.T.6264.

ZERBINOS, G., Sunshine; S.T.5186.

Application for renewal of licences as shown by the persons listed hereunder to operate under the same terms and conditions.

ANDRIANAKIS, N., West Brunswick; M.T.4359.

CRETNICK, D., Oak Park; M.T.4831.

DEPFELER, E. L., Herne Hill; U.T.701.

GODFREY, P. D., Warrnambool; C.T.541.

GREY, D. M. & P. C., Chewton; C.T.618.

K. R. LITTLE PTY. LTD., Daylesford; C.O.145, C.O.813,

C.O.983 and C.O.1153.

LOUTAS, K., Footscray; M.T.5450.

MURRELL, G. H. & L. H., Belmont; U.T.845.

MCLEAN, M. M., Newtown; U.T.704.

PANAGIOTOPOULOS, P., Thornbury; M.T.5644.

QUINCES SCENICRUISERS PTY. LTD., Murrumbidgee; M.C.657.

RANKINE, A. J. & J.; C.T.518.

SIMCOCKS, C. G., D. E. & J. M., Garfield; T.S.843, T.S.1526,

T.S.1527, T.S.1540, T.S.1549 and T.S.1564.

STAMOS, A., Oakleigh; M.T.5008.

TRPOSKOUFIS, G., Windsor; M.T.4726.

Notice of any objections should be forwarded to reach the Secretary of the Board not later than 11 June 1980.

Applicants are advised that it will not be necessary to appear on the hearing date specified, unless advised in writing by the Board.

C. J. V. SMITH, Secretary

Corner Lygon and Princes Streets, Carlton, 3053,  
Wednesday, 28 May 1980

Commercial Goods Vehicles Act  
TRANSPORT REGULATION BOARD

## HEARING OF APPLICATIONS

Notice is hereby given that the following applications will be considered by the Transport Regulation Board on 17 June 1980.

CLARKE MOBILE CRANES PTY. LTD., 269 Williamstown Road, Port Melbourne, 3208. One commercial goods vehicle (L/C. 1.05 tonne) to operate throughout the State of Victoria in the course of business as "Crane Hirer" for the purpose of servicing and maintaining own plant and equipment—tools of trade, spare parts and materials required for on-site servicing of such equipment.

**CONTROL SYSTEMS TOTALIZATORS PTY. LTD.**, 424 William Street, West Melbourne, 3003. One commercial goods vehicle (L/C. 0.80 tonne) to operate throughout the State of Victoria in the course of business as "Totalizator Operators"—own totalizators equipment and small quantity of materials incidental to the on-site servicing of such equipment.

**FASSO, J. L.**, 39 High Street, Heathcote, 3606. Application to vary the conditions of licence numbered D.A.52144/3 and D.A.52144/4 by adding to existing conditions an additional paragraph (b). From superphosphate works situated at Geelong to consignees situated in the area referred to in paragraph (a)—bulk and bagged superphosphate.

**Fox, G. J.**, 8 Rowan Court, Frankston North, 3200. Application to vary the conditions of licence No. D.A.69955 (L/C. 3.35 tonne and 1.95 tonne trailer) by deleting from existing conditions "40-km of the G.P.O. Melbourne and to points on the Mornington Peninsula" and adding in lieu "112-km of the G.P.O. Melbourne."

**Gow, D. W.**, Glen Alvie, 3979. Two commercial goods vehicles (L/C. 15.05 and 18.46 tonne) to operate: (a) From the premises of Rocla Pipes Ltd. at Springvale, Campbellfield and Traralgon, Concrete Industries (Monier) Ltd at Scoresby and Clyde and Humes Ltd at Brooklyn and Westall to own premises at Glen Alvie—concrete pipes. (b) From the premises of Boral/Glen Iris Bricks at Deer Park to own premises at Glen Alvie—masonry bricks and empty return of pallets. (c) From places within a 40-km radius of the G.P.O. Melbourne to own premises at Glen Alvie—secondhand cars, trucks and tractors. (d) Within an 80-km radius from the post office at Glen Alvie—bulldozers and agricultural earthmoving machinery the property of a contractor or the Country Roads Board. (e) Within that part of the State of Victoria east of a north/south line drawn through Werribee—livestock. (f) From places situated within a 40-km radius of the G.P.O. Melbourne to consignees situated within an 80-km radius of Glen Alvie in the course of business as "Demolition Contractor"—secondhand goods and materials salvaged from any demolition site. (g) From places within a 60-km radius of Glen Alvie to Braybrook—scrap metal. (h) From the premises of Victorian Railways at Spotswood to own premises at Glen Alvie—secondhand timber railway carriages and steel undercarriages. (i) From the premises of the SEC at Tottenham to own premises at Glen Alvie—timber and steel acquired from auction sales.

**JOHNSON, P.**, 58 Sherlock Road, Croydon, 3136. One commercial goods vehicle (L/C. 2.75 tonne) to operate: (a) Within an 80-km radius of own premises at Croydon in course of business as "Tractor and Agricultural Machinery Dealers"—own goods. (b) Throughout the State of Victoria for the purpose of sales promotion and demonstrating own tractors and agricultural equipment—tractors and agricultural equipment for demonstration, for repair or having been repaired, tools of trade, spare parts and materials required for on-site servicing and maintenance of tractors and agricultural equipment excluding the ability to deliver tractors or agricultural equipment except under paragraph (a).

**JOHNSTONE, A. A.**, 21 Station Avenue, St. Albans, 3021. Application to vary the conditions of licence number D.A.70875 by deleting "and to Geelong" and adding in lieu "and to places within a 16-km radius of the Chief Post Office in the City of Geelong".

**J. E. MORROW REFRIGERATION PTY. LTD.**, 19 Rowe Street, Shepparton, 3630. Two commercial goods vehicles (L/C. 1.15 and 1.15 tonne) to operate within an 80-km radius from the post office at Shepparton in the course of business as "Refrigeration, Air Conditioning and Washing Machine Servicemen"—tools of trade and materials incidental to the completion of own contracts.

**M. S. McLEOD LTD.**, 1297 Nepean Highway, Cheltenham, 3192. Two commercial goods vehicles (L/C. 0.80 and 0.75 tonne) to operate: (a) Within an 80-km radius of own premises at Cheltenham in the course of business as "Tyre and Wheel Manufacturers and Distributors"—own goods. (b) Throughout the State of Victoria for

the purpose of demonstration and display of tyres and wheels to prospective purchasers excluding the ability to make a delivery.

**Q.U.F. INDUSTRIES LTD.**, 99 Bell Street, Preston, 3072. One commercial goods vehicle (L/C. 2.65 tonne) to operate throughout the State of Victoria in the course of business as "Frozen Food Distributors" in a specially constructed refrigerated vehicle—frozen vegetables, frozen poultry, frozen fish and ice cream at a temperature not exceeding 0 degrees F.

**THEOLOGITIS, N.**, 4 Hunt Street, Bendigo, 3550. One commercial goods vehicle (L/C. 11.55 tonne) to operate: (a) Within an 80-km radius of the premises of Pioneer Concrete Victoria Pty. Ltd. at Bendigo, solely on behalf of the said Company—premixed concrete in a specially constructed agitator vehicle. (b) Within an 80-km radius of the chief post office at Bendigo—plant the property of a contractor and required for use in connection with the construction or maintenance of some specific, existing or proposed road, street, footpath, bridge, pier, wharf, weir or channel and also the following materials viz: metal, stones, screenings, ashes, gravel, sand and earth.

**UNDERWOOD, T. R.**, 21 Cornwall Avenue, Keysborough, 3173. One commercial goods vehicle (L/C. 3.70 tonne) to operate within an 80-km radius of the premises of the Forest Developments Aust. Ltd. at Dandenong in the course of business as "Installation Contractor" for the purpose of installing window frames solely on behalf of the said company—tools of trade, own equipment, window frames for specialised installation and materials used for the completion of such contract.

**WHITE, D. J.**, Fernbank R.S.D., Stratford, 3862. One commercial goods vehicle (L/C. 6.70 tonne) to operate: (a) Within a 40-km radius of the post office at Fernbank—general goods. (b) To farm properties situated within an 80-km radius from the post office at Fernbank—bulk fertilisers in a specially constructed vehicle subject to the condition that such goods so carried shall only be those having been initially consigned by rail to railway stations or sidings nearest to the points of final delivery.

**WHITE, H. G.**, Fernbank R.S.D., Stratford, 3862. One commercial goods vehicle (L/C. 9.00 tonne) to operate: (a) Within a 40-km radius of the post office at Fernbank—general goods. (b) To farm properties situated within an 80-km radius from the post office at Fernbank—bulk fertilisers in a specially constructed vehicle subject to the condition that such goods so carried shall only be those having been initially consigned by rail to railway stations or sidings nearest to the points of final delivery.

**WILKINS, R. L.**, 24 Princes Street, Traralgon, 3844. One commercial goods vehicle (L/C. 2.00 and 1.50 tonne trailer) to operate: (a) Within an 80-km radius of own premises at Traralgon in the course of business as "Plumbing Supplies and Contractors"—own tools of trade and equipment. (b) From places throughout the State of Victoria to own premises at Traralgon, an approved decentralised secondary industry (Engineering)—raw materials required for use in the manufacturing process of such industry. (c) From the said industry premises at Traralgon to places throughout the State of Victoria—goods having been manufactured at the approved decentralised secondary industry.

#### TOW TRUCKS

**ALSOP, A. J.**, 70-74 Mountjoy Parade, Lorne, 3232. One commercial goods vehicle (to be purchased) to operate within an 80-km radius of the post office at Lorne as a "Tow Truck" for the purposes of lifting and carrying or towing and/or repairing of wrecked or disabled vehicles—tools of trade, spare parts and materials incidental thereto.

**DUKER, N.**, 4/94 Princes Highway, Beaconsfield, 3807. One commercial goods vehicle (to be purchased) to operate within an 80-km radius of own premises at Narre Warren as a "Tow Truck" for the purposes of lifting and carrying or towing and/or repairing of wrecked or disabled motor vehicles—tools of trade, spare parts and materials incidental thereto.



## RENEWALS

Applications for renewal of licences as shown by persons listed hereunder to operate under the same terms and conditions from the expiry shown in each case.

- A.W.M. ELECTRICAL WHOLESALERS PTY. LTD., 44 Highway Road, Burwood, 3125; D.A.68597; 2 August 1980; 1.15 tonne; D.A.68597/1; 2 August 1980; 1.15 tonne; D.A.68597/2; 2 August 1980; 1.15 tonne.
- ACME OIL EQUIPMENT SERVICES PTY. LTD., 95 Bridge Road, Richmond, 3121; D.A.68603; 20 August 1980; 2.95 tonne.
- WILLIAM ADAMS TRACTORS PTY. LTD., Nantilla Road, Clayton, 3168; D.A.37873/2; 31 July 1980; 0.75 tonne.
- ALFA-LAVAL PTY. LTD., 56-60 Keon Parade, Keon Park, 3073; D.A.22799/28; 29 July 1980; 0.50 tonne.
- ALLENS SWEETS (Vic.) PTY. LTD., 2-14 Byrne Street, South Melbourne, 3205; D.A.2218/4; 25 July 1980; 2.00 tonne; D.A.2218/6; 25 July 1980; 3.85 tonne.
- ANSETT TRANSPORT INDUSTRIES PTY. LTD., 210 Gray Street, Hamilton, 3300; D.A.23228/18; 5 July 1980; 0.75 tonne.
- ARNOTT-BROCKHOFF GUEST PTY. LTD., 53 Huntingdale Road, Burwood, 3125; D.A.60213/78; 8 March 1980; 14.10 tonne.
- AVERY AUSTRALIA LTD., G.P.O. Box 173, Adelaide, 5001; D.A.6333/27; 27 June 1980; 0.80 tonne.
- BAKER PERKINS PTY. LTD., 10 Blissington Street, Springvale, 3171; D.A.64090/16; 16 July 1980; 0.50 tonne.
- BEAUREPAIRE TYRE SERVICE PTY. LTD., 83 Franklin Street, Melbourne, 3000; D.A.629/101; 31 August 1980; 0.75 tonne; D.A.629/98; 31 August 1980; 1.25 tonne; D.A.629/100; 31 August 1980; 0.75 tonne.
- BEER, I., Main Street, Strathmerton, 3641; D.A.27931/1; 25 July 1980; 6.70 tonne.
- BELL, I. J., 39 Benga Avenue West, Dandenong, 3175; D.A.47507/2; 29 July 1980; 6.60 tonne.
- BRAMBLES HOLDINGS LTD., 1846 Princes Highway, Clayton, 3168; D.A.39531/35; 11 July 1980; 1.25 tonne.
- BRIGGS, J. H., 12 Sunray Court, Croydon, 3136; D.A.52262; 7 July 1980; 6.90 tonne.
- BRIGGS, N. L., Licola Road, Heyfield, 3858; D.T.1014/3; 5 July 1980; 7.00 tonne.
- BURTON, A. N., 16 Tyson Road, Heyfield, 3858; D.T.1252; 19 February 1980; 14.20 tonne.
- CAMPBELLS TRANSPORT PTY. LTD., 905 Nepean Highway, Mornington, 3931; D.A.65485/7; 16 July 1980; 0.50 tonne.
- CENTRAL SYSTEMS TOTALIZATORS PTY. LTD., 424 William Street, West Melbourne, 3003; D.A.44775/3; 17 April 1980; 1.60 tonne.
- CLARKS COLDWAY PTY. LTD., P.O. Box 129, Bayswater, 3153; D.A.68489; 8 June 1980; 5.75 tonne; D.A.68489/1; 3 June 1980; 6.10 tonne.
- R. & L. COLLINS PTY. LTD., 410 Doncaster Road, Doncaster, 3108; D.A.53755/11; 14 August 1980; 0.70 tonne.
- COLLETT, G., 63 Biram Drive, Warragul, 3820; D.A.67723; 3 July 1980; 2.65 tonne.
- COMMONWEALTH INDUSTRIAL GASES LTD., THE, 90 Bell Street, Preston, 3072; D.A.838/42; 24 July 1980; 9.40 tonne.
- CONNOR SHEA & CO. PTY. LTD., Fourth Avenue, Sunshine, 3030; D.A.40050; 1 August 1980; 2.30 tonne.
- COONAN, M. J., 7 Duke Street, Yea, 3712; D.A.68567; 11 July 1980; 1.15 tonne.
- COUCHER, F. G., 48 Bardia Avenue, Seaford South, 3201; D.A.68404; 29 April 1980; 1.30 tonne.
- CURTIS, C. L., 14 Burwood Highway, Burwood, 3125; D.A.70352/1; 17 July 1980; 1.15 tonne.
- DALGETY AUSTRALIA LTD., 1 Malop Street, Geelong, 3220; D.A.46170/106; 27 April 1980; 0.75 tonne.
- DALGETY AUSTRALIA LTD., 461 Bourke Street, Melbourne, 3000; D.A.46170/88; 18 May 1980; 0.40 and 0.70 tonne trailer.
- DELANEY, J. J., 20 Townsend Road, Mortlake, 3272; D.A.37114/10; 8 July 1980; 12.75 tonne; D.A.37114/9; 8 July 1980; 12.75 tonne.
- DELLAVEDOVA, C., 25 Derby Road, Maryborough, 3465; D.A.1036/1; 5 June 1980; 6.50 tonne.
- DONALD, N. F. D., 39 Hertford Street, Sebastopol, 3356; D.A.68445; 13 May 1980; 1.10 tonne; D.A.68445/1; 13 May 1980; 1.15 tonne.
- ERIC CULLEN & SONS, 1 Hindon Street, Blackburn, 3130; D.A.924/1; 5 August 1980; 0.50 tonne.
- EUCLID TRUCKING CO. PTY. LTD., 22 Dynon Road, South Kensington, 3031; D.A.49715/4; 12 August 1980; 0.50 tonne; D.A.49715/3; 12 August 1980; 1.20 tonne; D.A.49715/2; 12 August 1980; 1.10 tonne.
- FLEET X PRESS PTY. LTD., 61 Bertie Street, Port Melbourne, 3207; D.A.66100/12; 18 July 1980; 6.05 tonne and 2.95 tonne trailer; D.A.66100/13; 18 July 1980; 12.50 tonne; D.A.66100/16; 18 July 1980; 6.50 tonne and 4.10 tonne trailer.
- FORD MOTOR CO. OF AUST. LTD., Princes Highway, Norlane, 3214; D.A.42814/17; 29 June 1980; 17.70 tonne.
- FROST, L. W., 51 Harper Street, Wangaratta, 3677; D.A.52459; 7 July 1980; 10.75 tonne and 3.85 tonne trailer.
- FULTON, C. R., 15 Hall Street, East Hawthorn, 3123; D.A.22273; 21 August 1980; 7.25 tonne.
- GASPAR, S., 4 Talbot Avenue East St. Kilda, 3182; D.A.63864; 29 June 1980; 7.90 tonne.
- GOULBURN VALLEY MOTORS PTY. LTD., 187 Wyndham Street, Shepparton, 3630; D.A.44390/3; 11 July 1980; 0.80 tonne.
- HAMILTON, S. J., 19 Helena Road, Lilydale, 3140; D.A.1224; 28 May 1980; 7.10 tonne.
- HEINZ, H. J., Co. AUST. LTD., Princes Highway, Dandenong, 3175; D.A.19069/1; 18 June 1980; 16.15 tonne; D.A.19069/4; 18 June 1980; 7.50 tonne; D.A.19069/6; 18 June 1980; 6.60 tonne.
- HEMINGWAY, LEO, & PICKETT PTY. LTD., 330 Sydney Road, Brunswick, 3056; D.A.39955; 25 July 1980; 2.00 tonne; D.A.39955/1; 25 July 1980; 1.95 tonne; D.A.39955/4; 25 July 1980; 1.90 tonne; D.A.39955/6; 25 July 1980; 3.35 tonne; D.A.39955/5; 25 July 1980; 2.40 tonne; D.A.39955/31; 25 July 1980; 1.90 tonne; D.A.39955/38; 25 July 1980; 1.50 tonne.
- HENDY, W. H., 35 Nightingdale Street, Ballarat, 3350; D.A.59860; 11 July 1980; 9.30 tonne.
- HERALD, THE, & WEEKLY TIMES LTD., 44-74 Flinders Street, Melbourne, 3000; D.A.1287; 23 June 1980; 1.55 tonne.
- HICKS, P. A., Elvian Road, Woori Yallock, 3139; D.A.51338; 7 July 1980; 7.65 tonne.
- HICKS W. G., PTY. LTD., 562 City Road, South Melbourne, 3205; T.D.A.62469/1; 1 July 1980; 4.00 tonne.
- IMPALA CARTAGE PTY. LTD., Brough Court, Springvale, 3171; D.A.61037/16; 5 July 1980; 16.95 tonne.
- JAMES, C. G., 1 Wright Street, Traralgon, 3844; D.A.67839; 17 July 1980; 12.00 tonne.
- JAMES, K. K., 12 Edinburgh Street, Warragul, 3820; D.A.61555/3; 3 April 1979; 6.40 tonne.
- JONKERS, G., P.O. Box 340, Orbost, 3888; D.T.1001; 1 July 1980; 20.27 tonne.
- KOLPIN, R. L., 26 11th Street, Mildura, 3500; D.A.68485; 19 July 1980; 2.70 tonne.
- LEAN, H., 86 Napier Street, Maryborough, 3465; D.A.61897; 1 July 1980; 6.15 tonne.
- MAJOR BUILDING SERVICE PTY. LTD., 27 McArthur's Road, North Altona, 3025; D.A.56523/20; 18 July 1980; 0.95 tonne.
- MALCOLM MCCLURE PTY. LTD., 30 Lawrence Street, Castlemaine, 3450; D.A.62751; 29 June 1980; 8.90 tonne and 10.95 tonne trailer.
- MAW, T. W., & SONS PTY. LTD., 821 Nepean Highway, Rosebud, 3939; D.A.39874/2; 11 July 1980; 10.95 tonne; D.A.39874/3; 11 July 1980; 11.80 tonne.
- MARTIN, D. L., 80 McIvor Road, Bendigo, 3550; D.A.65437; 24 July 1980; 0.75 tonne.
- MONAGHAN, K. J., 11 Vickers Street, Kialla, 3631; D.A.63454/3; 13 May 1980; 0.85 tonne.
- MUNRO, I. M., 42 Wimble Street, Seymour, 3660; D.A.47940/2; 3 June 1980; 7.00 tonne.
- MURRAY, F. S., Raglan Street, Yea, 3717; D.A.46331; 18 June 1980; 6.30 tonne.
- MCDONALD, W. L., Whitfield, 3733; D.A.1671/1; 2 June 1980; 6.30 tonne.
- N.C.R. AUSTRALIA PTY. LTD., 23-47 Villiers Street, North Melbourne, 3051; D.A.1707/93; 29 August 1980; 0.80 tonne.
- NELSON BROS. PTY. LTD., 7 Droop Street, Footscray, 3011; D.A.3611/4; 7 July 1980; 0.50 tonne.
- NICHOLS, D. S., 13 Jacaranda Street, Red Cliffs, 3499; D.A.70038; 26 August 1980; 2.65 tonne.
- O'BREE, B. A., 140 Thurla Street, Swan Hill, 3585; D.A.60856/1; 3 July 1980; 15.42 tonne; D.A.62292/1; 3 July 1980; 13.77 tonne.
- PAYNE, R. A., 11 Hinchcliff Crescent, Newcomb, 3219; D.A.36227; 16 June 1980; 7.05 tonne.
- POLAR DAIRIES (GEELOG) PTY. LTD., 30 Bloomsbury Street, Newtown, 3220; D.A.69634; 5 July 1980; 2.70 tonne.

W. PRIDHAM (AUST.) PTY. LTD., 11 Evans Street, Braybrook, 3019; D.A.1864/31; 26 July 1980; 9.30 tonne; D.A.1864/32; 26 July 1980; 9.90 tonne; D.A.1864/33; 26 July 1980; 10.30 tonne; D.A.1864/27; 26 July 1980; 10.65 tonne; D.A.1864/29; 26 July 1980; 6.30 tonne.

SANDERS, C. V., Conness Street, Chiltern, 3683; D.A.39627; 25 July 1980; 4.80 tonne.

SOUTHERN FARMERS CO-OP. LTD., French Street, Hamilton, 3300; D.A.63001/1; 19 July 1980; 0.50 and 1.60 tonne trailer.

SPILLER, H. H., 4 Mortoo Street, Swan Hill, 3588; D.A.61953; 15 July 1980; 0.65 tonne.

STEPHENSON, A. D., Sugarloaf Road, Beaconsfield Upper, 3808; D.A.67713; 12 June 1980; 0.50 tonne.

STRAMIT INDUSTRIES LTD., 96 Franklin Street, Melbourne, 3000; D.A.60553/8; 29 July 1980; 0.75 tonne; D.A.60553/6; 29 July 1980; 0.75 tonne; D.A.60553/7; 29 July 1980; 0.75 tonne.

STRAY, N. S., 29 Pinneger Street, Broadford, 3658; D.A.68440; 13 May 1980; 3.90 tonne.

SUTHERLAND, J. S., 17 Wheeler Street, Shepparton, 3630; D.A.61771; 17 June 1980; 2.70 tonne.

THOMAS, J. E., Box 217, Shepparton, 3630; D.A.55756/1; 5 July 1980; 0.50 tonne.

TONKS BROS. PTY. LTD., 224 Barker Street, Castlemaine, 3450; D.A.52462; 7 July 1980; 7.00 tonne.

TREVOR BOILER & ENGINEERING CO. PTY. LTD., corner Steel and Longford Streets, North Melbourne, 3051; D.A.28850/3; 16 June 1980; 0.85 tonne.

TURNBULL, D. R., 111 Dunlop Street, Mortlake, 3272; D.A.41048/1; 25 July 1980; 0.45 tonne.

VINCENT, N. W., 5 Greene Street, Bairnsdale, 3875; D.A.32384/2; 17 July 1980; 1.30 tonne.

WALCROFT BUILDING SERVICES PTY. LTD., 57 Henderson Road, Clayton, 3168; D.A.68588; 26 July 1980; 2.95 and 0.40 tonne trailer.

WARDEN, J. W., 19 Coniston Avenue, Berwick, 3806; T.D.A.66163; 9 July 1980; 12.65 tonne.

THE WARRNAMBOOL CHEESE & BUTTER FACTORY CO. LTD., Ocean Road, Allansford, 3277; D.A.55770/2; 21 June 1980; 7.35 tonne; D.A.55770/1; 21 June 1980; 7.35 tonne.

WILLIAMSON, R. T., 124 Grant Street, Alexandra, 3714; D.A.524/2; 23 April 1980; 15.00 tonne.

WILLIAMSON, R. T., 124 Grant Street, Alexandra, 3714; D.T.1671; 13 June 1980; 12.45 tonne.

## TOW TRUCKS

CARPENTER, C. N., 667 Waterdale Road, West Heidelberg, 3081; D.A.64294/2; 3 August 1980; 2.25 tonne; D.A.64294/3; 3 August 1980; 2.25 tonne.

CONSOLIDATED MOTOR INDUSTRIES PTY. LTD., 913 Mount Alexander Road, Essendon, 3040; D.A.45100/2; 11 June 1980; 1.90 and 0.65 tonne trailer.

RINGWOOD PANEL SERVICE PTY. LTD., 18 Molan Street, Ringwood, 3134; D.A.55208/2; 10 August 1980; 2.05 tonne.

SMITH, R. J., 46 Swan Walk, Chelsea, 3196; D.A.70162/1; 24 August 1980; 1.70 tonne.

TEMPLE TOWING & BODY WORKS PTY. LTD., 1127A North Road, South Oakleigh, 3167; D.A.59769/1; 19 August 1980; 1.50 tonne.

Notice of any objection should be forwarded to reach the Secretary of the Board not later than 11 June 1980.

Applicants are advised that it will not be necessary to appear on the hearing date specified above, unless advised in writing by the Board.

C. J. V. SMITH, Secretary

Corner Lygon and Princes Streets, Carlton, 3053, Wednesday, 28 May 1980

## Police Offences Act 1958, No. 6337

## DIVISION 1A—STATE CLASSIFICATION OF PUBLICATIONS BOARD

Take note that the State Classification of Publications Board has classified the following publications in accordance with the provisions of Section 180H (1) of the Police Offences Act 1958.

Each publication shall be subject to the following restrictions:

- it shall not be offered for sale, sold, delivered, exhibited or displayed to any person under the age of 18 years;
- it shall not be made available for inspection or perusal to any person under the age of 18 years;
- it shall not be exhibited or displayed in any place to which persons under the age of 18 years have access or so that it is visible from any such place;
- it shall not be advertised in any manner whatsoever.

## SCHEDULE OF PUBLICATIONS

Title	Distributor
Anal Antics	Borderline Distributors
Billie's Burning Desire	Claredale Holdings Pty. Ltd.
Blueboy—September 1979	Wathen Wholesale Pty. Ltd.
Blueboy—October 1979	Wathen Wholesale Pty. Ltd.
Blueboy Collection—Review Edition	Wathen Wholesale Pty. Ltd.
Burning Asses Vol. 11 No. 2	Claredale Holdings Pty. Ltd.
Cavalier—May 1980	Gordon & Gotch (A'sia) Ltd.
Coyote Vol. 1 No. 1	Claredale Holdings Pty. Ltd.
Cruise Nos. 46 and 47.	Wathen Wholesale Pty. Ltd.
Darleen and Her Ladies	Claredale Holdings Pty. Ltd.
Dominant Vixens Vol. 3 No. 4	Claredale Holdings Pty. Ltd.
Dominators, The Vol. 2 No. 1	Claredale Holdings Pty. Ltd.

Title	Distributor
For Women Only—November 1979	Wathen Wholesale Pty. Ltd.
Getting Off at the Rocks	Wathen Wholesale Pty. Ltd.
Good Life, The	Venus Enterprises Pty. Ltd.
Her Love of a Young Girl	Claredale Holdings Pty. Ltd.
In To The Hilt	Borderline Distributors
Kingsize Vol. 11 No. 1	Claredale Holdings Pty. Ltd.
Lovebirds No. 28	Claredale Holdings Pty. Ltd.
Marilyn and Sueanne	Claredale Holdings Pty. Ltd.
Mayfair Vol. 15 No. 6	Gordon & Gotch (A'sia) Ltd.
Milk Vol. 1 No. 2	Claredale Holdings Pty. Ltd.
My Sexual Preference	Borderline Distributors
Numbers—September 1979	Wathen Wholesale Pty. Ltd.
Numbers—October 1979	Wathen Wholesale Pty. Ltd.
Numbers Annual No. 3	Wathen Wholesale Pty. Ltd.
Numbers Hotline No. 4—Pool Play	Wathen Wholesale Pty. Ltd.
Qui Girls No. 1—Special Collectors Edition	Gordon & Gotch (A'sia) Ltd.
Pert & Pretty Vol. 2 No. 1	Claredale Holdings Pty. Ltd.
Prance Vol. 2 No. 1	Claredale Holdings Pty. Ltd.
Prima No. 11	Venus Enterprises Pty. Ltd.
Sex Party	Borderline Distributors
Sextoon Cartoons	Gordon & Gotch (A'sia) Ltd.
Stars Vol. 1 No. 1	Wathen Wholesale Pty. Ltd.
Superstars Of Porno, The	Venus Enterprises Pty. Ltd.
Swedish Erotica No. 29	Borderline Distributors
Teenage Sex No. 9	Wathen Wholesale Pty. Ltd.
Teenager No. 4	Claredale Holdings Pty. Ltd.
38.26.34 Vol. 17 No. 1	Claredale Holdings Pty. Ltd.
Unknown Lover, The	Borderline Distributors
Whitehouse No. 51	Claredale Holdings Pty. Ltd.

J. SMITH, Secretary  
State Classification of Publications Board

*Private Agents Act 1966*

## NOTICE OF RECEIPT OF APPLICATIONS FOR LICENCES UNDER THE PROVISIONS OF THE PRIVATE AGENTS ACT 1966

The Clerk(s) of the Magistrates' Court(s) as listed hereunder hereby give notice that applications, as under, have been lodged for hearing by the said Court(s) on the date(s) specified.

Any person desiring to object to any of such applications must—

- (a) lodge with the respective Clerk of the Magistrates' Court a notice in the prescribed form of his objection and of the grounds thereof ;
- (b) cause a copy of such notice to be served personally or by post upon the applicant at least three days before the hearing of the application ; and
- (c) send or deliver—
- (i) where the objection is not made by the officer in charge of the police district in which the Court is situated—a copy of the notice to such officer ; and
- (ii) where the objection is not made by the Registrar or Deputy Registrar—a copy to the Registrar.

Full Name of Applicant*	Place of Abode of Applicant or Nominee	Name of Firm or Corporation	Address for Registration	Type of Licence	Date of Hearing
MAGISTRATES' COURT, FERNTREE GULLY					
Vanderzanden, Anthony Theodore Sylvester	Lot 7, Verona St, Belgrave South		Lot 7, Verona St, Belgrave South	Process Server	11.6.80
Dated at Ferntree Gully 16 May 1980 B. DOBSON, Clerk of the Magistrates' Court					
MAGISTRATES' COURT, MORNINGTON					
Cheyne, Gregory John	28 Kambara Dr, Mulgrave	Bayside Guard Agents	65 Tyabb Rd, Mornington	Watchman	6.6.80
Dated at Dromana 16 May 1980 M. LEA, Clerk of the Magistrates' Court					
MAGISTRATES' COURT, DANDENONG					
Rizk, Alfred	66 Laemmle St, North Dandenong		66 Laemmle St, North Dandenong	Process Server	20.6.80
Dated at Dandenong 19 May 1980 J. T. KNIGHT, Clerk of the Magistrates' Court					
MAGISTRATES' COURT, MELBOURNE					
Hughes, Colin John	7 Meadowpark Lane, Mooroolbark	Armaguard	390 St Kilda Rd, Melbourne	Watchman	23.6.80
Dated at Melbourne 19 May 1980 M. QUIRK, Clerk of the Magistrates' Court					
MAGISTRATES' COURT, OAKLEIGH					
Adams, John Michael	4/19 Glen Ebor Ave, Blackburn		23 Avondale Gr, Mt Waverley	Watchman	19.6.80
Cox, Roy	7 High St, Dandenong		" "	" "	" "
Dated at Oakleigh 19 May 1980 I. CLOAK, Clerk of the Magistrates' Court					
MAGISTRATES' COURT, YARRAM					
Alford, Brian Reginald	2 Walpole Crt, Yarram	Wormald International Security	340 Abbotsford St, North Melbourne	Watchman	20.6.80
Triantafyllou, Michael	South Gippsland Hwy, Woodside	" "	" "	" "	" "
Cook, Barry Howard	10 Nightingale St, Yarram	" "	" "	" "	" "
Dated at Yarram 19 May 1980 J. W. KEE, Clerk of the Magistrates' Court					
MAGISTRATES' COURT, GEELONG					
Harcombe, Robert Hugh	15 Blue Waters Dr, Ocean Grove	Armaguard	390 St. Kilda Rd, Melbourne	Watchman	17.6.80
Dated at Geelong 19 May 1980 J. E. REILY, Clerk of the Magistrates' Court					

\* Or in the case of a firm or corporation, of the Nominee

PRIVATE AGENTS—continued

Full Name of Applicant*	Place of Abode of Applicant or Nominee	Name of Firm or Corporation	Address for Registration	Type of Licence	Date of Hearing
<b>MAGISTRATES' COURT, BALLARAT</b>					
Slack, Wayne John	2 Sangria Crt, Mt. Clear, Ballarat	George Laurens (Vic.) Pty. Ltd.	17 Doveton St, North Ballarat	Commercial Sub-Agent Process Server	12.6.80
" " "	" "	" "	" "	" "	"
Dated at Ballarat this 21 May 1980 D. CROFT, Clerk of the Magistrates' Court					
<b>MAGISTRATES' COURT, RINGWOOD</b>					
Humphrey, Jack Peter	14 Ware Cres, East Ringwood		14 Ware Cres, East Ringwood	Process Server	13.6.80
Dated at Ringwood 21 May 1980 P. O'FARRELL, Clerk of the Magistrates' Court					
<b>MAGISTRATES' COURT, SPRINGVALE</b>					
Higgins, Raymond John	121 Kidd Rd, Doveton		41 Fairview St, Springvale	Watchman	11.6.80
Fleer, Friedhelm Johann	32 Maryanne Way, Mt. Waverley		11 Wardale Rd, Springvale South	Commercial Sub-Agent	"
Dated at Springvale 20 May 1980 P. COUTTS, Clerk of the Magistrates' Court					
<b>MAGISTRATES' COURT, SUNBURY</b>					
Millett, Stephen James	Horne St, Sunbury		Horne St, Sunbury	Watchman	17.6.80
Dated at Sunbury 20 May 1980 L. F. HANDLEY, Clerk of the Magistrates' Court					
<b>MAGISTRATES' COURT, FERNTREE GULLY</b>					
Coyle, Winston Walker Wallace	3 Harwell Rd, Ferntree Gully		3 Harwell Rd, Ferntree Gully	Guard Agent	18.6.80
Dated at Ferntree Gully 21 May 1980 B. DOBSON, Clerk of the Magistrates' Court					

\* Or in the case of a firm or corporation, of the Nominee

LAND SETTLEMENT ACT  
LEASE SURRENDERED

Notice is hereby given that the Rural Finance Commission, pursuant to the powers conferred upon it by the Land Settlement Act has accepted the surrender of the lease mentioned in the Schedule hereunder for the reason specified.

Corr. No.	Name	Section of Act No 6534 under which Leased	Parish	Allotment	Area	Reason
605/14	A. J. Seabrook	14	Rochester West	62 Section F	Hectares 47	At Lessee's Request
21 May 1980						G. McG. BAKER Deputy Secretary Rural Finance Commission

SUPPLEMENT NUMBER 21  
Health Act 1958

ADDITIONS TO, OMISSIONS FROM, AND AMENDMENTS OF, THE REGISTER OF PROPRIETARY MEDICINES  
Published in accordance with the provisions of the Health Act 1958, Section 265 (3)

Health Commission Melbourne B. P. McCLOSKEY, Director  
Public Health Division

The following is an ADDITION to the Register of Proprietary Medicines.

Distinctive Name of Proprietary Medicine	Serial Number	Date of Registration	Name and Address of Applicant	Purposes for which the Medicine may be sold
Tetley Zest Lemon	18171	14.5.80	Tetley Tea Co. Ltd. London c/o Robert Timms Pty. Ltd. 162 Rouse St, Port Melbourne	As a powdered beverage base with added Vitamin

## Water Act 1958

## STATE RIVERS AND WATER SUPPLY COMMISSION

## BELLARINE URBAN DISTRICT

Notice to owners of tenements in the under-mentioned streets in the Bellarine Urban District and the private streets, lanes, courts and alleys opening thereto:

*Anglesea*

O'Donohue Road, from end of existing main (opposite Lot 1) to a point opposite Lot 3 about 60 metres southerly.

*Birregurra*

Ennis Street, from Skene Street to Sladen Street.  
Sladen Street, from end of existing main (opposite Lot 4, Section 0) to Ennis Street.

*Clifton Springs**Barrands Lane—*

- (1) From Parrakoola Drive to a point opposite Lot 1889 about 215 metres southerly.
- (2) From Leawarra Way to a point opposite Lot 1846 about 110 metres southerly.

Bayshore Avenue, from end of existing main (opposite Lot 7 of L.P.80892) to Spring Street about 234 metres easterly.

Catalpa Court, from end of existing main (opposite Lot 855) to a point opposite Lot 861 about 110 metres easterly.

Coorumbly Avenue, from end of existing main (opposite Lot 2610) to Takanna Avenue about 100 metres easterly.

Country Club Drive, from end of existing main (opposite Lot 933) to Coronae Drive about 220 metres southerly.

Dandarriga Drive, from end of existing main (opposite Lot 2583) to a point opposite Lot 2597 about 144 metres south easterly.

Delungra Avenue, from Minda Court to a point opposite Lot 2907 about 80 metres south easterly.

*Dundundra Drive—*

- (1) From Delungra Avenue to Wardoo Court.
- (2) From Wanawong Court to Thamballina Road.

Gwinganna Drive, from Dundundra Drive to a point opposite Lot 2816 about 110 metres easterly and northerly.

*Kirra Way.**Korong Court.*

Mirrabooka Drive, from Marraboora Avenue to Goondiwindi Avenue.

Panpandi Drive, from end of existing main (opposite Lot 3030) to opposite Lot 3042 about 200 metres easterly.

Parrakoola Drive, from Lacoora Avenue to Barrands Lane.

*Patonga Court.**Takanna Avenue.**Turana Avenue.**Wanawong Court.**Drysdale*

Barrands Lane, from East Street to a point opposite Lot 153 about 550 metres northerly.

Duke Street, from end of existing main (opposite Lot 5) to East Street about 85 metres north easterly.

Princess Street, from Huntingdon Street to a point opposite Lot 1 of Part of Crown Allotment 3A, Section 3, Parish of Bellarine about 636 metres southerly.

*Indented Head*

Adam Street, from end of existing main (opposite Lot 119) to Brett Drive about 180 metres westerly.

Brett Drive, from end of existing main (opposite Lot 47) to Portarlington—St. Leonards Road about 130 metres southerly.

Portarlington—St. Leonards Road, from end of existing main (opposite Lot 99) to a point opposite Lot 144 about 220 metres westerly.

*Jan Juc**Ayr Street.*

Duffields Road, from Meaby Street to a point opposite Lot 90 about 192 metres southerly.

*Holstock Court.*

Muirfield Avenue, from end of existing main (opposite reserve) to Duffields Road about 25 metres westerly.

Nicholson Crescent, from Meaby Street to a point opposite Lot 109 about 209 metres southerly.

*Trevenen Court.**Wattle Court.**Ocean Grove**Chelsea Court.*

Somerdale Avenue, from end of existing main (opposite Lot 453) to a point opposite Lot 420 about 350 metres northerly.

Tuckfield Street, from Dare Street to a point opposite Lot 1 about 65 metres southerly.

*Tudor Court.**Point Lonsdale*

Beachwood Drive, from end of existing main (opposite Lot 100) to Santa Monica Boulevard about 130 metres westerly.

*Diggora Court.*

Emily Street, from end of existing main (opposite Lot 193) to a point opposite Lot 34 about 185 metres north westerly.

Hollywood Boulevard, from Beachwood Drive to Pico Avenue.

*Loch Street.*

Norman Crescent, from end of existing main (opposite Lot 59) to a point opposite Lot 69 about 150 metres westerly.

*Portarlington*

Fairfax Street, from Langdon Street to a point opposite Lot 1, Section 21, about 120 metres northerly.

Langdon Street, from end of existing main (opposite Lot 16, Section 34A) to Harding Street about 101 metres easterly.

*Peels Court.*

Stevens Street, from Simpson Street to a point opposite Lot 1, Section 14 about 87 metres easterly.

Traum Street, from end of existing main (opposite Lot 61) to a point opposite Lot 64 about 120 metres westerly.

*Torquay*

Castaway Crescent, from Ocean Boulevard to a point opposite Lot 11 about 300 metres southerly.

Ocean Boulevard, from Sunset Strip to a point opposite Lot 1 about 125 metres easterly.

Sunset Strip, from Ocean Boulevard to a point opposite Lot 2 about 55 metres westerly.

*Wallington*

Swan Bay Road, from end of existing main (opposite Lot 5) to a point opposite Lot 7 about 132 metres easterly.

The main pipe in the said streets being laid down, the owners of all tenements situated as above are hereby required, on or before 1 July 1980 next, to cause proper pipes and stop cocks to be laid, so as to supply water within such tenements from the main pipe.

Armada, 29 April 1980

R. BIRD, Secretary  
State Rivers and Water Supply Commission

Water Act 1958  
STATE RIVERS AND WATER SUPPLY COMMISSION  
COLIBAN URBAN DISTRICT

Notice to owners of tenements in the undermentioned streets in the Coliban Urban District and the private streets, lanes, courts and alleys opening thereto:

*Bendigo*

Arnold Street, from Holt Street to a point opposite Crown allotment 1A, section 57c, Parish of Sandhurst, about 8 metres north-westerly.

Carpenter Street, from end of existing main (opposite lot 1 L.P.111381) to a point opposite lot 3 L.P.88514 about 68 metres southerly.

Connelly Street, from Houston Street to a point opposite lot 4 L.P.56061 about 68 metres southerly.

Craig Court, from end of existing main (opposite Crown allotment 48E, section A, Parish of Sandhurst) to a point opposite Crown allotment 9g, section A, Parish of Sandhurst, about 15.6 metres easterly.

Franklin Street, from Growler Street to a point opposite Crown allotment 10, section 5b, Parish of Sandhurst, about 78.7 metres westerly.

Ham Street, from Golden Gully Road to a point opposite Crown allotment 9A, section H3, Parish of Sandhurst, about 410 metres easterly.

McInnes Street, from end of existing main (opposite lot 2 L.P.12367) to a point opposite lot 6, section D, Parish of Mandurang, about 156.7 metres southerly.

Richards Street.

Rohs Road—

- (1) From end of existing main (opposite Crown allotment 240b, Parish of Sandhurst) to Rowena Street.
- (2) (West side only), from end of existing main (opposite Crown allotment 363d, Parish of Sandhurst) to a point opposite the southern boundary of Crown allotment 363g, Parish of Sandhurst, about 70 metres northerly.
- (3) From end of existing main (opposite southern boundary of Crown allotment 363g, Parish of Sandhurst) to a point opposite Crown allotment 363g, Parish of Sandhurst, about 10 metres northerly.

Rowena Street, from Rohs Road to a point opposite lot 1 L.P.111216 about 45 metres westerly.

Timbertop Drive, from end of existing main (opposite lot 28) to a point opposite lot 26 L.P.95488 about 47.7 metres northerly.

*Castlemaine*

Farrell Avenue, from end of existing main (opposite lot 7, section 147, Parish of Castlemaine) to a point opposite Crown allotment 9b, section H, Parish of Castlemaine, about 148 metres easterly.

Railway Avenue, from Britton Street to Farrell Avenue.

Wilkie Street, from end of existing main (opposite lot 2 L.P.73783) to a point opposite lot 1 L.P.73783, about 21 metres northerly.

*Chewton*

Mitchell Street, from Pitman Street to a point opposite Crown allotment 193A, section E, Parish of Chewton, about 105 metres westerly.

*Eaglehawk*

Buckie Street, from end of existing main (opposite Crown allotment 138, section M, Parish of Sandhurst) to Bailey Street, about 58.8 metres westerly.

Fry Street, from end of existing main (opposite lot 2) to Reef Street about 116 metres northerly.

Gill Avenue—

- (1) From end of existing main (opposite lot 12 L.P.25127) to a point opposite lot 2 L.P.125102 about 283 metres easterly.
- (2) From end of existing main (opposite lot 13 L.P.123313) to a point opposite lot 12 L.P.131109 about 201 metres easterly.

New Street, from Green Street to a point opposite lot 13, L.P.82467, about 137 metres easterly.

*Epsom*

Station Street, from end of existing main (opposite lot 1) to a point opposite Crown allotment 6b, section 27, Parish of Huntly, about 123 metres northerly.

*Golden Square*

Hughes Street, from Wilmot Street to a point opposite Crown allotment 13A, section 41b, Parish of Sandhurst, about 63 metres northerly.

*Harcourt*

Blackjack Road, from end of existing main (opposite Crown allotment 13, section 5c, Parish of Harcourt) to a point opposite Crown allotment 20A, Parish of Harcourt, about 89 metres easterly.

*Huntly*

Chesney Street, from Main Road to a point opposite Crown allotment 104, Township of Huntly, about 200 metres easterly.

Rennie Street (east side only), from Stephenson Street to a point opposite lot 6, about 176 metres northerly.

*Kangaroo Flat*

Calder Highway, from end of existing main (opposite Crown allotment 141, section D, Parish of Mandurang) to a point opposite Crown allotment 29A, section D, Parish of Mandurang, about 450 metres northerly.

Elda Court.

Phillis Street, from end of existing main (opposite lot 2 L.P.131373) to a point opposite lot 3 L.P.131373, about 12 metres easterly.

*Maiden Gully*

Edwards Road—

- (1) From Marong Road to a point opposite Crown allotment 112b, Parish of Marong, about 70 metres north-westerly.
- (2) From Smiths Road to a point opposite lot 2 L.P.69463, about 660 metres westerly.

Monsants Lane—

- (1) (West side only), from Carolyn Way to a point opposite Crown allotment 76A, about 80 metres southerly.
- (2) From end of existing main (about 160 metres southerly from Carolyn Way) to a point opposite lot 2 L.P.128475, about 320 metres southerly from Carolyn Way.

Schumakers Lane—

- (1) From Marong Road to a point opposite the southern boundary of lot 7 about 80 metres northerly.
- (2) (West side only), from end of existing main (opposite southern boundary of lot 7) to a point opposite lot 1 about 292 metres northerly.

Smiths Road—

- (1) (West side only), from Edwards Road to a point opposite lot 4, about 205 metres northerly.
- (2) From end of existing main (opposite lot 4) to Marong Road, about 197 metres north-easterly.

*Maldon*

Unnamed Road (off Church Street), from Church Street to a point opposite Crown allotment 21, section 3E, Parish of Maldon, about 160 metres easterly.

*Spring Gully*

Carey Court.

*Strathfieldsaye*

Lawrence Road, from Sullivans Road to a point opposite lot 12, about 425 metres northerly.

Strathfieldsaye—Junortoun Road, from Sullivans Road to a point opposite Crown allotment 1b, Parish of Strathfieldsaye, about 39 metres northerly.

Sullivans Road, from end of existing main (opposite lot 4 L.P.11997) to a point opposite Crown allotment 12, Parish of Strathfieldsaye, about 180 metres easterly.

Taylor Lane, from Sullivans Road to a point opposite Crown allotment 34, section 19, Parish of Strathfieldsaye, about 223.7 metres southerly.

*White Hills*

Crane Street (south side only), from Watson Street to Jacob Street.

Harveys Lane, from Edwards Road to a point opposite lot 2 L.P.96169, about 162.1 metres northerly.

Jacob Street, from Edwards Road to a point opposite Crown allotment 3, section F12, Parish of Sandhurst, about 46 metres southerly.

Washington Street—

(1) From Harveys Lane to the eastern boundary of Crown allotment 49, section N1, Parish of Sandhurst, about 340 metres easterly.

(2) (South side only), from eastern boundary of Crown allotment 49, section N1, Parish of Sandhurst, to Watson Street, about 260 metres easterly.

The main pipe in the said streets being laid down, the owners of all tenements situated as above are hereby required, on or before 1 July 1980, next, to cause proper pipes and stop cocks to be laid, so as to supply water within such tenements from the main pipe.

Armadale, 12 May 1980

R. BIRD, Secretary  
State Rivers and Water Supply Commission

*Water Act 1958*

STATE RIVERS AND WATER SUPPLY COMMISSION  
OTWAY URBAN DISTRICT

Notice to owners of tenements in the undermentioned streets in the Otway Urban District and the private streets, lanes, courts and alleys opening thereto:

*Cobden*

Mitchell Street, from Adams Street to end of existing main (opposite Lot 15) about 196 metres westerly.

The main pipe in the said streets being laid down, the owners of all tenements situated as above are hereby required, on or before 1 July next, to cause proper pipes and stop cocks to be laid, so as to supply water within such tenements from the main pipe.

R. BIRD, Secretary  
State Rivers and Water Supply Commission  
Armadale, 28 May 1980

MOE WATERWORKS TRUST

INCREASING THE LIMIT OF BANK OVERDRAFT

His Excellency the Governor of the State of Victoria, by and with the advice of the Executive Council thereof, doth by Order made on 27 May 1980, increase the total amount of the sums which the Moe Waterworks Trust may owe at any one time in respect of moneys borrowed by overdraft of current account pursuant to the provisions of section 288 of the *Water Act 1958*, fixed by the Governor in Council on 8 November 1972, at Thirty thousand dollars (\$30 000) to Two hundred thousand dollars (\$200 000).

TOM FORRISTAL  
Clerk of the Executive Council

At the Executive Council Chamber  
Melbourne, 27 May 1980

*Cemeteries Act 1958*

SCALE OF FEES OF THE BOORT PUBLIC CEMETERY

In pursuance of the powers conferred upon them by the *Cemeteries Act*, the trustees of the Boort Public Cemetery hereby make the following scale of fees, which shall come into operation upon publication in the *Government Gazette*, and from and after such publication every scale of fees heretofore made by the said trustees shall be and is hereby rescinded to the extent to which it conflicts with this scale.

*Sinking Charges for Private Graves*

	\$
Sinking grave 1.83 m deep	62.00
Each additional 0.3 m	13.00
Sinking oversize grave (extra)	25.00

*Reopening Charges*

Reopening grave (no cover)	52.00
Reopening grave (with cover)	60.00

A. F. STREADER, Trustee  
R. H. WEBB, Trustee  
I. L. STREADER, Trustee

Approved by the Governor in Council, 20 May 1980—  
TOM FORRISTAL, Clerk of the Executive Council

*Cemeteries Act 1958*

SCALE OF FEES OF THE BRIGHTON GENERAL CEMETERY

In pursuance of the powers conferred upon them by the *Cemeteries Act*, the trustees of the Brighton General Cemetery hereby make the following scale of fees, which shall come into operation upon publication in the *Government Gazette*, and from and after such publication every scale of fees heretofore made by the said trustees shall be and is hereby rescinded to the extent to which it conflicts with this scale.

*Lawn and Monumental Areas*

	\$
Land 2.44 m x 1.22 m, trustee selection	275.00
Land 2.44 m x 1.22 m, own selection	300.00
Sinking grave 2.13 m	195.00
Reopening grave	195.00
Reopening grave inside monument	215.00
Interment of ashes in grave	70.00
Exhumation (when authorised)	375.00

*New Memorial Wall*

Niche	65.00
Reservation (extra)	10.00

J. N. ALEXANDER, Trustee  
J. H. GODWIN, Trustee  
W. ALFORD, Trustee

Approved by the Governor in Council, 20 May 1980—  
TOM FORRISTAL, Clerk of the Executive Council

*Cemeteries Act 1958*

SCALE OF FEES OF THE CHELTENHAM PUBLIC CEMETERY

In pursuance of the powers conferred upon them by the *Cemeteries Act*, the trustees of the Cheltenham Public Cemetery hereby make the following scale of fees, which shall come into operation upon publication in the *Government Gazette*, and from and after such publication every scale of fees heretofore made by the said trustees shall be and is hereby rescinded to the extent to which it conflicts with this scale.

*Lawn and Monumental Areas*

	\$
Land 2.44 m x 1.22 m, at need	270.00
Land 2.44 m x 1.22 m, pre-need	290.00
Land 2.44 m x 1.22 m, special position, at need	290.00
Land 2.44 m x 1.22 m, special position, pre-need	310.00
Standard interment fee	165.00

*Placement of Cremated Remains*

Niche in memorial wall, including standard plaque as supplied by the trust	70.00
Niche in memorial wall, including plaque with vase as supplied by the trust	80.00
Ground niche, plaque extra	100.00
Interment in lawn or monumental grave, plaque (extra)	40.00
Memorial trees, plaque (extra from)	200.00
Memorial shrubs and roses, plaque (extra from)	100.00
Memorial boulders, plaque (extra from)	100.00
Lawn positions, plaque (extra from)	75.00

*Miscellaneous Charges*

Annual maintenance of monumental graves (optional service)—	
Single grave 2.44 m x 1.22 m	20.00
Double grave 2.44 m x 2.44 m	25.00
	F. W. Le PAGE, Trustee
	J. KELLY, Trustee
	J. McDERMID, Trustee

Approved by the Governor in Council, 20 May 1980—  
TOM FORRISTAL, Clerk of the Executive Council

*Cemeteries Act 1958*

SCALE OF FEES OF THE DIMBOOLA PUBLIC CEMETERY

In pursuance of the powers conferred upon them by the Cemeteries Act, the trustees of the Dimboola Public Cemetery hereby make the following scale of fees, which shall come into operation upon publication in the *Government Gazette*, and from and after such publication every scale of fees heretofore made by the said trustees shall be and is hereby rescinded to the extent to which it conflicts with this scale.

*Private Graves*

	\$
Land 1.22 m x 0.9 m (for child's grave)	25.00
Land 2.44 m x 1.22 m	60.00
Own selection of site (extra)	10.00

*Sinking Charges for Private Graves*

Sinking grave to depth of 1.22 m	25.00
Sinking grave to depth of 1.53 m	30.00
Sinking grave to depth of 1.83 m	60.00
Each additional 0.3 m	10.00
Sinking oversize grave (extra)	20.00
Sinking oversize grave for American type casket (extra)	25.00
Cancellation of order to sink (if commenced)	3.00
Plus excavated depth per 0.3 m	10.00
Interment of ashes in private grave	25.00
Sinking a grave on Saturdays, Sundays and Public Holidays	20.00

*Reopening Charges*

Reopening 2.13 m grave (no cover)	60.00
Reopening 2.13 m grave (with cover)	65.00
Reopening 2.44 m grave	70.00

*Extra Charges*

Interment fee	20.00
Interment fee (stillborn and child under one year)	10.00
Interment fee in private grave with less than eight hours' notice	25.00

*Miscellaneous Charges*

Number peg and grave marker	6.00
Removing and replacing ledgers	10.00
Breaking scalings and removing gravel	10.00
Exhuming remains of a body (when authorised)	100.00
Permission to erect headstone or monument— 5 per cent. of cost, minimum \$8.00.	
Permission to construct a brick grave or to erect any stone, kerb, tilework or concrete	9.00
Additional inscriptions on monuments	4.00
Annual maintenance (single grave) if required by holder of right of burial	21.00
Memorial wall niche and plaque	60.00

L. A. MENZEL, Trustee  
R. T. SCHULLER, Trustee  
R. T. FEERY, Trustee  
P. C. GOODING, Trustee

Approved by the Governor in Council, 20 May 1980—  
TOM FORRISTAL, Clerk of the Executive Council

*Cemeteries Act 1958*

SCALE OF FEES OF THE NHILL PUBLIC CEMETERY

In pursuance of the powers conferred upon them by the Cemeteries Act, the trustees of the Nhill Public Cemetery hereby make the following scale of fees, which shall come into operation upon publication in the *Government Gazette*, and from and after such publication every scale of fees heretofore made by the said trustees shall be and is hereby rescinded to the extent to which it conflicts with this scale.

*Private Graves*

	\$
Land 2.438 m x 1.219 m (8 ft x 4 ft)	12.00
Own land selection (extra)	2.00

*Public Graves*

Interment in grave without exclusive right—still-born child	6.00
Interment in grave without exclusive right—others	12.00

*Sinking Charges for Private Graves*

Sinking grave 1.828 m (6 ft) deep	70.00
Each additional 0.304 m (1 ft)	15.00
Sinking oversize grave (extra)	15.00
Sinking oversize grave for American type casket (extra)	15.00
Cancellation of order to sink (if commenced)	10.00

*Reopening Charges*

Reopening grave (no cover)	59.00
Reopening grave (with cover or kerb)	79.00

*Extra Charges*

Interment not in the prescribed hours or on Saturdays, Sundays or Public Holidays	30.00
-----------------------------------------------------------------------------------	-------

*Miscellaneous Charges*

Interment fee	10.00
Certificate of right of burial	1.00
Inspection of plan or register	1.00
Permission to erect a headstone or monument— 5 per cent. of cost, with a minimum of \$6.00	
Permission to construct a brick grave or to erect any stone kerb, brick, tilework or concrete	4.00
Exhuming the remains of a body (when authorised)	100.00
Interment of ashes in a private grave	15.00

J. E. CURKPATRICK, Trustee  
W. H. BOUND, Trustee  
L. H. MULHALLEN, Trustee

Approved by the Governor in Council, 20 May 1980—  
TOM FORRISTAL, Clerk of the Executive Council

*Cemeteries Act 1958*

SCALE OF FEES OF THE TATURA PUBLIC CEMETERY

In pursuance of the powers conferred upon them by the Cemeteries Act, the trustees of the Tatura Public Cemetery hereby make the following scale of fees, which shall come into operation upon publication in the *Government Gazette*, and from and after such publication every scale of fees heretofore made by the said trustees shall be and is hereby rescinded to the extent to which it conflicts with this scale.

*Lawn Section*

	\$
Lawn grave 2.44 m x 1.22 m, at need	250.00
Lawn grave 2.44 m x 1.22 m, pre-need (when available)	300.00
For each interment therein	130.00
Bronze plaque 380 mm x 280 mm	70.00
Flower container	25.00
Exhuming the remains of a body (when authorised)	200.00



Memorials

	\$:
Memorial niche wall and plaque	80.00
Memorial tree	180.00
Memorial shrub	90.00
Bronze plaque for memorial trees and shrubs	90.00

W. J. CRAVEN, Trustee  
 T. P. FLANAGAN, Trustee  
 A. V. CARR, Trustee

Approved by the Governor in Council, 20 May 1980—  
 TOM FORRISTAL, Clerk of the Executive Council

Cemeteries Act 1958

SCALE OF FEES OF THE YEA PUBLIC CEMETERY

In pursuance of the powers conferred upon them by the Cemeteries Act, the trustees of the Yea Public Cemetery hereby make the following scale of fees, which shall come into operation upon publication in the Government Gazette, and from and after such publication every scale of fees heretofore made by the said trustees shall be and is hereby rescinded to the extent to which it conflicts with this scale.

General Cemetery

	\$:
Land 2.44 m x 1.22 m	12.00
<i>Sinking Charges for Private Graves</i>	
Sinking grave 1.83 m deep	70.00
Sinking grave 2.13 m deep	82.00
Sinking oversize grave (extra)	10.00
Stillborn child	36.00
Cancellation of order to sink (if commenced)	10.00

Reopening Charges

Reopening grave with cover	75.00
Reopening grave without cover	60.00
Reopening for stillborn child	30.00

Extra Charges

Interment outside prescribed hours, or on Saturdays, Sundays or Public Holidays	18.00
Interment fee	5.00
Permission to erect a headstone or monument— 2½ per cent of cost	

Lawn Cemetery

Land 2.44 m x 1.22 m	60.00
<i>Sinking Charges for Private Graves</i>	
Sinking grave 1.83 m deep	70.00
Sinking grave 2.13 m deep	82.00
Sinking oversize grave (extra)	10.00
Stillborn child	36.00
Cancellation of order to sink (if commenced)	10.00

Reopening Charges

Reopening each grave	70.00
----------------------	-------

Columbarium

Niche and plate	50.00
-----------------	-------

Extra Charges

Interment outside prescribed hours, or on Saturdays, Sundays or Public Holidays	18.00
Interment fee	10.00

D. S. McLEISH, Trustee  
 C. M. McCARTHY, Trustee  
 I. J. MACINTYRE, Trustee

Approved by the Governor in Council, 20 May 1980—  
 TOM FORRISTAL, Clerk of the Executive Council

Melbourne and Metropolitan

BOARD OF WORKS

GENERAL NOTICE

The Melbourne and Metropolitan Board of Works having made provision for carrying off the sewage of each and every property which or any part of which is situated in the Sewerage Areas hereinafter described doth hereby declare that on and after 2 June 1980 each and every property so situated shall be deemed to be a sewerer property within the meaning of the Melbourne and Metropolitan Board of Works Act 1958.

The Sewerage Areas hereinbefore referred to are:—

Sewerage Area No. 3959

City of Knox—This area comprises lots 1 to 7, those pieces of land described on Certificates of Title Volume 8922 folio 548, Volume 8820 Folio 459 and Volume 8664 Folio 731; lots 467, 436 to 434, 348 to 346, that piece of land described on Registered Plan No. 11595, lots 261, 260, 470, 478 and 479 Springfield Road; lots 477 to 475 Woodvale Road, lots 474 to 471 Maryborough Road; lots 8 to 11, a Reserve, those pieces of land described on Certificates of Title Volume 8100 Folio 706 and Volume 8100 Folio 707, lots 448 to 446, 463 to 459, that piece of land described on Registered Plan No. 5910 and lot 457 Hazelwood Road, lots 437 to 440, that piece of land described on Registered Plan No. 6063, lots 442 to 444, that piece of land described on Registered Plan No. 9540, lots 451 to 456 and 464 to 466 Narcissus Avenue; lots 256 to 259, 349 to 357 and 423 to 433 Tulip Crescent; lots 265 to 263 and 345 to 342 Pine Crescent; that piece of land described on Plan of Consolidation No. 100443, lots 361 to 358 and 422 to 420 Stradbroke Road; a Drainage and Sewerage Reserve abutting Hazelwood Road, Narcissus Avenue and Stradbroke Road.

Sewerage Area No. 3962

City of Knox—This area comprises all lots in Warrieng Court, Dillon Road, Bolac Street, Waranga Road and Willison Street, lots 26, 27, 1 to 4, 6 to 10 and 9 to 3 Victoria Road, lots 2, 1, 2, 1, 9 to 3, 2, 1, 70, 71 and 34 to 31 Scoresby Road; lots 30 to 21 Mitre Crescent, lots 7 to 3, 2, 1 and a further lot 1 Orange Grove, lots 28 to 30, 40 and 41 Wiltshire Avenue, lots 47, 46, 22, 21, 22 to 19, a Reserve, lots 25 to 23, 20, 19 and 13 to 11 Lance Road, those pieces of land described on Certificates of Title Volume 6998 Folio 473 and Volume 8962 Folio 939 abutting Elizabeth Street and Victoria Road, a Reserve abutting Willison Street and Lance Road.

Sewerage Area No. 3976

City of Caulfield—This area comprises all lots in Patterson Street, lots 3, 4 and 5 to 8 Hunter Street, lots 114 to 123 and 130 to 138 Longstaff Street, lots 98, 99, 124 to 127, 128 and 129 Boake Street, lot 1 North Road, lots 2 and 4 Murrumbidgee Road, part of Duncan Mackinnon Reserve abutting North Road and Murrumbidgee Road.

Sewerage Area No. 3998

City of Berwick—This area comprises all lots in St. James Court, lots 278, 277, 258, 257, 239, 238 and 286 to 279 Saxonwood Drive; lots 256 to 249 and 248 to 240 St. Johns Court.

Sewerage Area No. 4000

City of Broadmeadows—This area comprises all lots in Marina Close, Lyre Court and Ronald Close, Lots A, 104 to 101, 93 to 86, 80 to 77 and 54 to 76 Lenoak Street, lots 30 to 6, 33 to 36 and 45 to 53 Cassandra Drive, lots 1 to 4, 32, 31 and 5 Trentham Drive.

Sewerage Area No. 4001

City of Croydon—This area comprises lots 56 to 54 and 5 Narool Court, lots 7, 6, 53 to 47, 77, 78 and 57 to 65 Wallara Crescent, lots 66 to 69 and 26 to 30 Desmond Road, lots 31 to 44, 45, 46 and 76 to 70 Araluen Drive, lots 1 to 14 and 15 to 26 Eastfield Road, lots 24, 23 and 22 to 19 Gumtree Close, lots 14 to 11 and 10 to 5 Pinetree Close, a Reserve abutting Pinetree Close and Gumtree Close.

**Sewerage Area No. 4003**

City of Knox—This area comprises all lots in Oakfield Court, lots 11, 12, 9 to 18, 20 and 21 Sasses Avenue, lots 22 to 29, 31 to 43, 3, 44 to 47, 57 to 65 and 19 Enfield Drive, lots 13 to 25, 1, 2 and 4 to 8 Victoria Road, a Reserve abutting Victoria Road, Ozon Road and Lance Road, an MMBW Pipe Track abutting Victoria Road and Enfield Drive.

**Sewerage Area No. 4005**

City of Knox—This area comprises all lots in Park Boulevard, California Crescent, Colorado Court, Florida Drive, Virginia Way, Loretto Avenue, Malva Road, Moira Avenue, Linda Crescent and Helen Road, lots 199 to 207 Scoresby Road, lots 208 to 211, 667, 666, 702 to 705, 738 to 734, 874 and 713 to 706 Manuka Drive, Fairpark Reserve abutting Scoresby Road, Manuka Drive and Park Boulevard, Fairhills Primary School abutting Manuka Drive and California Crescent, a Drainage and Sewerage Reserve abutting Manuka Drive and Rankin Road, lots 212 to 220, 247, 248, 272 and 275 James Road, lots 198, 197, 221, 222, 249 to 257, 383 to 394, 464 to 476 and 39 to 43 Bursaria Avenue, lots 44 to 48, 59 to 63, 74 to 76, that piece of land described on Plan of Consolidation No. 101529, lots 1, 89 to 93, 6 to 12, 24 to 15, 1 to 3 and 5 to 7 McMahons Road, lots 584, 569, 570, 541, 540, 518, 517, 493, 492, 491, 490, 463, 462, 396, 395, 366, 365, 362, 568, 586 and 587 Lightwood Drive, lots 32 to 18, 597, 596, 557, 556, 348 to 351, 379 to 382, 1, 2, 260, 261, 288 to 291, 645, 644, 618, 617 and 785 to 793 Johnson Drive, lots 794 to 797, 831 to 829, 858 and 853 to 843 Rankin Road, lots 19 and 30 Wells Avenue, lot 33, that piece of land described on Registered Plan No. 6542, lot 35, a Reserve, a further Reserve, lot 25 and that piece of land described on Certificate of Title Volume 8071 Folio 196 Norvel Road, a Reserve at the rear of that piece of land described on Certificate of Title Volume 8071 Folio 196 Norvel Road.

**Sewerage Area No. 4006**

City of Knox—This area comprises lots 5 and 6 Devenish Road.

27 May 1980

By order of the Board

O. T. W. COSGRIFF, Secretary

625 Little Collins Street, Melbourne, Vic. 3000

## Victoria

## ACT 391—SECOND SCHEDULE

A Statement of Trusts having been submitted by the head or authorised representative of the denomination of the Church of England in the Diocese of Wangaratta pursuant to the provisions of the "Act to provide for the abolition of State Aid to Religion" for allowance by His Excellency the Governor (the same was allowed by him on 20 May 1980) and the following is the form in which such statement of trusts has been allowed.

## STATEMENT OF TRUSTS

**Description of Land**—Site for Church of England Place of Public Worship and Minister's Dwelling, temporarily reserved by Order in Council of 7 March 1870 (see *Government Gazette*, 11 March 1870)—6070 square metres, Parish of Barwidgee, County of Bogong, being Crown allotment B103. Commencing at the eastern-most angle of Crown allotment B155; bounded thence by a road bearing 110 deg. 47 min. 60.35 metres; and thence by Crown allotment B101 bearing 200 deg. 47 min. 100.58 metres, 290 deg. 47 min. 60.35 metres and 20 deg. 47 min. 100.58 metres to the point of commencement—(C.101670).

**Name of Trustees**—The Church of England Trusts Corporation for the Diocese of Wangaratta of Wangaratta aforesaid.

**Powers of Disposition**—Power to sell lease mortgage or exchange all or any part of such land subject to the approval of the Bishop of Wangaratta for the time being or during the absence of the Bishop from the Diocese or the vacancy of the See to the approval of the person for the time being administering the affairs thereof. The land until otherwise disposed of to be held for the purpose for which it was granted or reserved by the Crown.

**Purposes to which Proceeds of Disposition are to be Applied**—To such purposes of the Church of England as may be agreed upon by:

- (1) The Bishop or during his absence from his See or during the vacancy thereof by the person or persons for the time being administering the affairs of the Diocese.
- (2) The Trustees of the Church of England Trusts Corporation for the Diocese of Wangaratta.
- (3) The Minister entitled to occupy the aforesaid land.

As witness, the hand of the Governor of the State of Victoria, 20 May 1980.

HENRY WINNEKE  
Governor of the State of Victoria

## Urban Renewal Act 1970

## SHIRE OF CHARLTON

URBAN RENEWAL PROPOSAL  
Housing Commission, Victoria

The objects of the proposal are:—

- to improve the tone of the overall area by developing the underused, landlocked area for housing;
- to solve problems of access to the area;
- to reassemble land where allotments are poorly subdivided;
- to encourage a more coherent residential pattern;
- to clean up vacant blocks;
- to offer loans for the renovation of buildings; and
- to provide a study which would indicate those matters which must be treated for the better use of the area, consistent with its present character and future potential.

A copy of the proposal may be inspected during office hours at the Shire Offices, Charlton, at the office of the Town and Country Planning Board, 235 Queen Street, Melbourne, and at the office of the Neighbourhood Redevelopment Division, Ministry of Housing, 10th Floor, 250 Elizabeth Street, Melbourne.

All persons affected by the renewal proposal, who object to any matter contained in the proposal or who wish to make any submission with respect to the proposal, must set forth in writing to the Neighbourhood Redevelopment Division, Ministry of Housing, G.P.O. Box 1670N, Melbourne, 3001, by 28 August 1980 all objections which they may have or submissions which they may wish to make in respect to the proposal and state whether they wish to be heard in respect of their objections and submissions.

N. GREEN, Manager, Administration  
Housing Commission, Victoria

NOTE—Previous notices relating to the above Urban Renewal Proposal, published in *Government Gazette*, No. 29, of 23 April 1980 and *Government Gazette*, No. 33, of 7 May 1980 are incorrect.

NOTICE TO MARINERS  
[No. 24 of 1980]

## AUSTRALIA—VICTORIA

## PORT PHILLIP

## Light Buoy Character Changed

Previous Notice—No. 48 of 1979 refers.

Details—The light characteristic of the No. 5 South Channel light buoy detailed in the above notice has been amended to Quick Flash.

All other details remain unaltered.

Abridged Description—Q.

A. J. WAGGLEN, Port Officer

Public Works Department  
Ports and Harbors Division  
168 Exhibition Street  
Melbourne, 3000, 14 May 1980

CONTRACTS ACCEPTED—(Series 1979-80)				AMENDMENTS—continued			
AMENDMENTS				Schedule Number	Item Number	New Rate	Effective Date
Schedule Number	Item Number	New Rate	Effective Date				
\$							
<i>Antiseptics, Disinfectants, Deodorants and Insecticides</i>				<i>Soaps and Soap Mixtures</i>			
1/01	11	0.485†	9.5.80	1/15	2	7.58†	9.5.80
	12	0.435†		† Less 1%, 30 days.			
† Less 1%, 30 days.				<i>Motor Spirit, Kerosene, Fuel Oils and Lubricants</i>			
<i>Electrical Goods</i>				Outlets:			
1/05	38	56.60	21.5.80	Add: Nelson, Mobil, Nelson Roadhouse, Nelson			12.5.80
	40	86.89	7.5.80	Delete: Torquay, Mobil, Bernell Caravan Park,			9.5.80
	45	23.83		Geelong Road			
	57	83.85	17.3.80	<i>Photographic and X-ray Equipment</i>			
	64	420.12†	21.5.80	1/55	113	11.50	2.5.80
† Plus \$14 Installation Fee.					114	17.25	
<i>Laundry Chemicals</i>					262	13.55†	5.5.80
1/11	1	21.575†	9.5.80		263	50.40†	
	2	13.83†		† 3 Types.			
	3	41.775†		<i>Hand Tools (General)</i>			
	6	18.16†		1/56	51	25.91 (No. 2)	12.5.80
† Less 1%, 30 days.					202	8.88	
<i>Painters' Brushware, Rollers and Signwriters' Pencils</i>					205	7.88	
1/12	31	1.80	1.5.80		221	6.00	
	32	1.88		<i>Motor Vehicles</i>			
	33	2.07		1/58	6	4634.00†	14.5.80
	34	2.60			8	5148.00	
	35	3.15		† Plus \$85.00 Delivery Charge.			
	36	1.56		<i>Stationery, General</i>			
	37	1.99		1/64	72	8.63	22.4.80
	38	2.31			141	0.855	17.4.80
	42	2.01			153	2.99	
	43	2.62		<i>Provisions—Melbourne and Metropolitan District</i>			
	44	3.07		2/01	148	22.13	1.5.80
	49	8.35 (0.6-1.2 m)		<i>Provisions—Warrnambool District</i>			
		11.29 (1.2-2.4 m)		2/25 (A)	10	1.35†	8.5.80
		15.03 (1.8-3.6 m)			21	0.99*	
	50	13.75		† 375 g.			
	51	2.78 (270 mm)		* 500 g.			
		6.15 (270 mm Trade)		J. M. PAWSON, Secretary to the Tender Board			
<i>Protective Clothing, Uniforms and Safety Equipment</i>							
1/14	2	11.02	11.2.80				
	2	11.63	15.5.80				
	41	20.50	1.4.80				

CONTRACTS ACCEPTED—(Series 1979-80)

PUBLIC WORKS

Cyclic maintenance, Geelong East Technical School No. 7165, \$40 957.00—A. H. Foster & Co., Newtown.

Removal, re-erection and renovation of L.T.C. Classroom from Bass Primary School No. 847 to Glen Alvie Primary School No. 3203, repairs and painting to all buildings on site at Glen Alvie Primary School No. 3203, \$21 000.00—Alf. Richardson Constructions Pty. Ltd., Benalla.

Supply and fix roof cladding, P.W.D. Construction Group Depot, 237 Napier Street, Fitzroy, \$10 967.00—Amalgamated Roofing Industries, East Brunswick.

Replace boundary fencing, Maribyrnong High School No. 8015, \$11 679.05—A.R.C. Engineering Pty. Ltd., Sunshine.

Supply and deliver 7 No. Relocatable Modular Buildings, F.O.G. Port Melbourne, various sites, \$277 529.00—Bowater Tutt Industries Pty. Ltd., Ballarat.

Building Works, Piangil Lands Residence, McGreadie Street, Piangil, \$38 951.00—Blunts Homes, Shepparton.

Supply and delivery 6 No. Relocatable Modular Buildings, F.O.G. Port Melbourne, Various Sites in State of Victoria, \$222 270.00—Cemac Associated Ltd., Reservoir.

Extension of heating to administration building and workshop, Gresswell Rehabilitation Centre, Bundoora, \$20 847.00—Chadstone Air Conditioning Services Pty. Ltd., Glen Waverley.

Internal and external repairs and painting, Merrilands High School No. 8040, \$62 750.00—Colore Decorating Co. Pty. Ltd., Reservoir.

Sewerage treatment plant and associated work, Pearce-dale Primary School No. 2961, \$21 460.00—Diston Water Purification Pty. Ltd., Vermont.

Supply and installation of sawdust extraction unit, Sunshine Technical School No. 7350, \$15 690.00—D. M. Beaumont, Ballarat East.

External and part internal renovations and painting, Surrey Hills Primary School No. 2778, \$36 450.00—Buckle Painting Company, North Melbourne.

Heating of wards, mechanical services, Hobson Park Mental Hospital, Traralgon, \$102 050.00—Ekon Industries Pty. Ltd., Morwell.

External repairs and painting, Karingal Primary School, No. 4922, \$28 130.00—E.P. Painting Service, Vermont South.

Supply and deliver 1 No. 5 Module Relocatable Modular Administration Building, F.O.G. Port Melbourne, various sites in the State of Victoria, \$53 107.00—Evertsbrook Pty. Ltd., Pascoe Vale.

External repairs and painting, Frankston Heights Primary School No. 4815, \$17 700.00—F. Boschini Holdings Pty. Ltd., East Bentleigh.

Annual maintenance of fire alarms, 1 April 1980 to 31 March 1981, various, \$13 162.00—F.F.E. Services (Vic.) Pty. Ltd., Carlton South.

Alterations to sheetmetal workshop, mechanical services, Morwell Technical School No. 7265, \$19 998.00—F.I.N.S. Heating, Warragul.

Site works, asphalt repairs, Mount Waverley Primary School No. 3432, \$23 200.00—Flexi-Pave, Endeavour Hills.

Site works, Leongatha High School No. 7990, \$30 988.00—Flexi-Pave, Endeavour Hills.

Erection of multi purpose room canteen and site works, Portland Primary School No. 489, \$217 937.00—Fotheringham Constructions Pty. Ltd., Warrnambool.

Extension to fire services, Upwey High School No. 8415, \$19 200.00—F. Sunderland & Sons, Bayswater.

Renewal of roof, Noble, Park Technical School No. 7280, \$35 482.00—F. Sunderland & Sons, Bayswater.

Service to L.P. gas heaters, 1980, various schools, Eastern Metropolitan Region, \$10 140.00—Gas & Fuel Corporation of Victoria, Hawthorn.

Conversion of oil fired boilers to natural gas, Heidelberg Technical School No. 7190, \$18 214.00—Gas & Fuel Corporation of Victoria, Melbourne.

Erection of new extensions, Preston Technical School No. 7296, \$579 203.00—Graham Evans & Co. (Vic.) Pty. Ltd., Melbourne.

Site works, Foster High School No. 7845, \$40 899.00—Guenther Mueller, Keysborough.

External and internal repairs and painting, Maldon Primary School No. 1254, \$17 620.00—I. Bulat, North Balwyn.

Internal and external repairs and painting, additions and improvements, Seaspray Primary School, No. 4324, \$14 250.00—Ivan Bulat, North Balwyn.

Electrical reticulation, Ardoch Education Village, Prahran, \$50 845.00—Jarrett & Crikis Pty. Ltd., Fairfield.

Theatre complex, change rooms and toilets, Vermont High School No. 8420, \$64 900.00—J. A. J. Lohman Pty. Ltd., Bayswater North.

Replacement of roof sheeting, Warragul High School No. 8435, \$70 243.55—J. B. & S. E. Heenan, Warragul.

Supply, delivery and erection of 1 No. 22 Module Relocatable Building, complete with services and site works, Ashwood C.G.C.S. Centre, \$266 234.00—Jennings Industries Ltd., Mulgrave.

Supply and delivery 8 No. Relocatable Modular Buildings, F.O.G. Port Melbourne, various sites in the State of Victoria, \$202 872.00—Jennings Industries Ltd., Mulgrave.

Upgrading of administration area, Hopetoun High School No. 7920, \$10 769.00—J. & G. Panozzo, Horsham.

Annual maintenance of lifts, 1 April 1980 to 31 March 1981, various, \$168 548.00—Johns Perry Industries Pty. Ltd., South Melbourne.

Extensions to fire services and water supply, Sunshine West High School No. 8360, \$18 900.00—J. R. & B. L. Kendall, Greensborough.

Provision of staff toilets and storeroom, Architectural, Warburton Primary School No. 1485, \$14 057.00—Lapthorne & Knowles, Mt. Evelyn.

Internal and part external repairs and painting, Rosamond Special School, \$32 000.00—Lewton Building Services, Carlton.

Installation of fire service, Burwood High School No. 7675, \$15 350.00—L. & H. Maxa Plumbing, McCrae.

Replacement of fire services, Burwood Heights Primary School, No. 4932, \$18 600.00—L. & H. Maxa Plumbing, McCrae.

Road construction, asphalt work, Glen Waverley Police Training Academy, \$23 760.00—L. J. Towers, Carnegie.

Supply and installation of indial equipment, Town and Country Planning Board Offices, 235 Queen Street, Melbourne, \$18 220.00—L.M. Ericsson Pty. Ltd., Preston.

Connection of hydraulic services, Whittlesea Technical School No. 7408, \$15 000.00—Morang Plumbing and Drainage, South Morang.

External repairs and painting, Huntingdale Primary Schools No. 4716, \$19 163.00—McDermott Painting and Maintenance Pty. Ltd., Croydon South.

Supply and installation of park system, State Government Offices, Ballarat, \$70 711.00—Nec Australia Pty. Ltd., Mulgrave.

Installation of thermol fire alarm system, Mildura State Government Offices, \$15 886.00—O'Donnell Griffin Pty. Ltd., Clifton Hill.

Supply and delivery of 4 No. Relocatable Modular Buildings, F.O.G. Port Melbourne, various sites in the State of Victoria, \$144 676.00—Pepita Kieron Nominees Pty. Ltd., Bendigo.

Supply and commissioning of Communication Control Centre, Stage 1, Police and Emergency Services, Police Station, Russell Street, \$2 150 984.00—Philips—TMC, Clayton.

Melbourne, external repairs and painting, McKinnon High School, No. 8125, \$31 730.00—Pilgrim Painting and Renovations, Footscray.

Concrete work, Seaford Primary School No. 3835, \$13 200.00—Polman Constructions, Coburg.

Electrical services, Doncaster High School No. 7776, \$11 976.45—P.R. Electrics Pty. Limited, Mt. Waverley.

Alterations and additions to existing building, Library, Beaconsfield Upper Primary School No. 2560, \$98 712.00—P. T. Dawes & Co. Pty. Ltd., Eltham.

Accommodation changes, Stage 2, Community Welfare Services, 55 Swanston Street, Melbourne, \$27 981.00—Quadric Pty. Ltd., South Melbourne.

Erection of staff toilets, Geelong East Technical School No. 7165, \$35 000.00—Raymore Constructions, Geelong West.

Renewal of fire service and water main, Ararat H.M. Prison, \$30 578.00—R. D. Cooke Pty. Ltd., West Heidelberg.

Internal repairs and painting, Turana Youth Training Centre, Remand "B", Parkville, \$11 280.00—Redac & Co. Pty. Ltd., Kew.

Site works and relocatables, Whittlesea Technical/High School No. 7408, \$13 124.00—Rex Paving, West Brunswick.

Hire of caterpillar 955H, Portland-Dutton Way, and rates, R. C. Wallace, Cartage Contractor, Portland.

External repairs and painting to office and laboratory building and residences 4, 5 and 6, Tobacco Research Station, Myrtleford, \$11 750.00—R. & I. Painters, Keilor East.

Module brick veneer library, Stawell High School No. 8340, \$66 900.00—R. Loeliger Pty. Ltd., Ararat.

Staff/administration, library upgrade, Mildura West Primary School No. 3983, \$60 506.00—Sandor Constructions Pty. Ltd., Mildura.

Site development, Werribee Technical School No. 7402, \$37 553.00—Shire of Werribee, Werribee.

External repairs and painting, and internal repairs and painting, Axedale Primary School No. 1008, \$10 210.00—Sixth-Vemalux Pty. Ltd., Golden Square.

Site works, Altona West Primary School No. 4862, \$31 984.98—S. J. Moran Constructions Pty. Ltd., Clayton.

Maintenance of oil burners, 1980-81, Western Metropolitan, various schools, \$13 558.00—S. & R. Airconditioning and Electrical Services, Coburg.

Internal and external renovations, Nowa Nowa Primary School No. 3738, \$20 447.00—"Sta-Brite" Painting and Decorating Service, Orbest.

Erection of new school buildings, Wonthaggi North Primary School No. 3716, \$798 466.38—S. W. & J. Gardiner Pty. Ltd., Frankston.

Supply and delivery of 8 No. Relocatable Modular Buildings, F.O.G. Port Melbourne, various sites in State of Victoria, \$154 952.00—Tranbuild Geelong Pty. Ltd., (Corio).

Connection to sewer, Sunbury West Primary School No. 5006, \$13 693.00—Tulmel Plumbing and Drainage Pty. Ltd., Tullamarine.

Erection of 24-hour Police Station and Divisional Offices, Hastings, \$679 808.00—Van Driel (Aust.) Pty. Ltd., as Trustee, Caulfield.

Erection of new school building, Ardeer High School No. 7522, \$1 186 061.00—Van Driel (Aust.) Pty. Ltd., as Trustee, Caulfield.

New kiosk building, Hobson Park Mental Hospital, Trairagon, \$90 900.00—W. G. Campbell Constructions Pty. Ltd., Morwell.

General repairs, external and part internal renovations and painting, Myrtleford High School No. 8120, \$46 657.00—Wolff's Painting Service, Benalla.

Heating and hot water service, Sunbury Mental Hospital, Male Hostel, \$30 987.00—W. S. Atherton & Co. Pty. Ltd., Lower Templestowe.

D. J. LITTLE, Director General of Public Works. 20.5.80

#### CONTRACTS ACCEPTED—(Series 1979-80)

##### PUBLIC WORKS

His Excellency the Governor of the State of Victoria by and with the advice of the Executive Council thereof has by Orders made on 20 May 1980, approved of the acceptance by the Minister of Public Works of the under-mentioned offers without public tenders being invited, viz.:

Offer of L. W. Heuzinkveld, for internal repairs and painting—Gowerville Primary School for the sum of Ten thousand eight hundred and thirty-five dollars (\$10 835.00)—(C.37579).

Offer of T. M. S. Pty. Ltd. for provision of a sprinkler system at Melton Technical School for the sum of Thirteen thousand five hundred and thirty-four dollars (\$13 534.00)—(W.227204).

Offer of Myer Teale Group for provision of carpet, Police Building, Russell Street, Melbourne, for the sum of Thirty-seven thousand nine hundred and one dollars (\$37 901.00)—(CG/C.185884E).

Offer of Gas and Fuel Corporation of Victoria, for provision of gas heating system at Batman Automotive College, Coburg, for the sum of One hundred and two thousand eight hundred and eighteen dollars (\$102 818.00)—(C.187120K).

Offer of Carousel Irrigation Pty. Ltd. for provision of sprinkler system to portable complex at Wantirna High School for the sum of Ten thousand four hundred and ninety-nine dollars and seventy cents (\$10 499.70)—(N.204920K).

Offer of Eggleston MacDonald & Secomb for professional services (Architectural) at various locations, Property and Services Division for the sum of Seventy-five thousand dollars (\$75 000.00)—(B.G.161810).

Offer of Owen I. Boyd, for electrical installation at the Paynesville Shipwright Shop for the sum of Fifteen thousand nine hundred and fifty-nine dollars and eighty cents (\$15 959.80)—(P.H.167092).

Offer of Pongrass Industries Ltd. for supply of seating units at Moe High School for the sum of Twelve thousand two hundred and forty dollars (\$12 240.00)—(S.05-8060/07).

Offer of Cemac Constructions & Manufacturing, a Division of Cemac Associated Ltd. for supply and delivery of 1 No. 5 module relocatable building to the P.W.D. Storeyard, Port Melbourne, for the sum of Forty-three thousand eight hundred and seventy-four dollars (\$43 874.00)—(B.G.161713"E").

Offer of Hawker Siddeley Engineering Pty. Ltd. for supply of spare parts to Ports and Harbors Division Vessel M.V. "Matthew Flinders" for the sum of Thirty-three thousand and sixty-nine dollars ninety-two cents (\$33 069.92)—(P.&H.166638).

Offer of Wormald Electrics for annual maintenance of fire alarms for period 1 April 1980 to 31 March 1981 at various locations for the sum of Nineteen thousand three hundred and twenty-eight dollars (\$19 328.00)—(C.V.192170).

Offer of Shire of Morwell for special grant towards construction of oval at Maryvale High School for the sum of Ten thousand nine hundred and ninety-nine dollars eighty-one cents (\$10 999.81)—(E.8426).

TOM FORRISTAL

Clerk of the Executive Council

At the Executive Council Chamber  
Melbourne, 20 May 1980

#### Labour and Industry Act 1958

##### ORDER OF EXEMPTION UNDER SECTION 80C

Whereas pursuant to section 80c of the *Labour and Industry Act 1958* as amended by the *Labour and Industry (Further Amendment) Act 1969* the City of Geelong West has applied to the Minister for an order exempting certain shopkeepers of shops in its municipal district from being required to close and keep closed their shops in accordance with Part VI. of the said Act:

Now therefore I, James Halford Ramsay, Her Majesty's Minister of Labour and Industry in the State of Victoria, do pursuant to the aforesaid section 80c of the *Labour and Industry Act 1958*, make this order, granting exemption, to Maggs and Co., 222 Pakington Street, Geelong West, in the City of Geelong West from being required to close and keep its shop on Saturdays between the hours of 1 p.m. and 5 p.m. and Sundays and public holidays between the hours of 9 a.m. and 1 p.m. provided that such exemption shall not apply to Good Friday or Anzac Day.

Dated at Melbourne, 9 May 1980

J. H. RAMSAY

Minister of Labour and Industry

#### DEPARTMENT OF MINERALS AND ENERGY

Subject to any necessary excisions, &c., it is proposed to grant the following Mining Lease:—

No. 680; Noel Thomas Burns, Robert Burns, Paul Joseph Burns; 12.4 ha, Parish of Weston.

#### APPLICATION FOR EXPLORATION LICENCE DECLARED ABANDONED

No. 692; Endeavour Resources Limited; 396 km<sup>2</sup>, County of Benambra.

#### APPLICATION FOR EXPLORATION LICENCE REFUSED

No. 853; North Broken Hill Ltd.; 462 km<sup>2</sup>, Counties of Bendigo and Gunbower.

#### EXPLORATION LICENCE GRANTED

No. 831; Ashton Mining NL; 792 km<sup>2</sup>, comprising Gromatic Blocks Nos. 781, 782, 783, 853, 854, 855, 925, 926, 927, 997, 998, and 999 Hamilton Map Sheet, Counties of Borung and Kara Kara.

**AREA OF APPLICATION FOR EXPLORATION LICENCE  
RELINQUISHED**

Freeport of Australia Incorporated; comprising Graticular Blocks Nos. 1361, 1433, 1435, 1436, 1437, 1503, 1504, 1505, 1506, 1507 and 1508 Melbourne Map Sheet.

**TERMS OF EXPLORATION LICENCES EXTENDED**

No. 618; Uplands Finance Pty. Ltd.; 264 km<sup>2</sup>, County of Talbot.

No. 624; Australian Anglo American Prospecting Limited; 264 km<sup>2</sup>, County of Benambra.

**APPLICATIONS FOR SEARCH LICENCES REFUSED**

No. 1703; Noel Frank Garland, Lionel Edward Whitting; 10 ha, Parish of Sandhurst.

No. 1744; Gavinda Pty. Ltd.; 40 ha, Parish of Magorra.

No. 1745; Gavinda Pty. Ltd.; 40 ha, Parish of Magorra.

No. 1746; Gavinda Pty. Ltd.; 40 ha, Parish of Bogong North.

**SEARCH LICENCES GRANTED**

No. 1352; Castlemaine Engineering & Mining Co. Pty. Ltd.; 3136 ha, Parish of Terrick Terrick West.

No. 1360; Leslie Gordon Newton; 7 ha, Parish of Eldorado.

No. 1552; Robert Eric Prestige; 39 ha, Parish of Blackwood.

**SEARCH LICENCE EXPIRED**

No. 1219; O.P.U. Ciolo, L. Long; 41.8 ha, Parishes of Fryers and Drummond.

**TAILINGS LICENCES GRANTED**

No. 4463; A. G. Leech Pty. Ltd.; to remove tailings from the "Band of Hope Mine Dump" situated in the Township of Bowenvale.

No. 4471; Shire of Bet Bet; to remove tailings from "Mitchells Pit" approximately 1.5 km north of the Township of Tarnagulla.

No. 4479; Henry Lewis Righye; to remove tailings from the "South New Moon Shaft".

No. 4480; Shire of Talbot and Clunes; to remove tailings from the "Union Mine Dump" situated in the Parish of Amherst.

No. 4494; Maxwell Emmitt; to remove tailings from the "Windmill Hill Mine Mullock Dump" situated at Long Gully.

**TAILINGS LICENCES EXPIRED**

No. 3982; Shire of Wangaratta; to remove tailings from mine dumps or deposits situated in the Parish of Byawatha.

No. 4277; Victor Mucha; to remove tailings situated at the Old Battery Site, north of Chiltern.

**EXTRACTIVE INDUSTRY LEASE GRANTED**

No. 243; The Readymix Group (Vic.); 8.8 ha, Parish of Charlton East.

**APPLICATION FOR EXTRACTIVE INDUSTRY LICENCE  
REFUSED**

No. 1055; D. N. & S. Constructions Pty. Ltd.; 16 ha, Parish of Bylands.

**EXTRACTIVE INDUSTRY LICENCES GRANTED**

No. 791-1; James Alfred Hammill; 7.5 ha, Parish of Warragul.

No. 990; Rosedale Sand Supply Pty. Ltd.; 11.1 ha, Parish of Holey Plains.

No. 1005; William John Anderson, Maree Ann Anderson; 3.7 ha, Parish of Mepunga.

No. 1008; Lake Cooper Quarries Pty. Ltd.; 3.8 ha, Parish of Burrumbout.

No. 1026; Ronald James Chenery; 7.3 ha, Parish of Skipton.  
J. C. M. BALFOUR  
Minister for Minerals and Energy

**MINING LEASES DECLARED VOID**

No. 538; Noel Thomas Burns, Robert Burns, Paul Joseph Burns; 11.6 ha, Parish of Weston.

No. 539; Noel Thomas Burns, Robert Burns, Paul Joseph Burns; 0.7 ha, Parish of Weston.

B. W. COURT  
Secretary for Minerals and Energy

*Town and Country Planning Act 1961*

**CITY OF CROYDON PLANNING SCHEME 1961**

AMENDMENT No. 92

*Notice of Approval*

In pursuance of the powers conferred by the *Town and Country Planning Act 1961*, the Governor in Council on 20 May 1980, approved a planning scheme entitled the City of Croydon Planning Scheme 1961, Amendment No. 92 in respect of part of the municipal district of the City of Croydon and such planning scheme comes into operation on the date this Notice of Approval is published in the *Government Gazette*.

A copy of the planning scheme as approved may be inspected, free of charge, during office hours at the office of the Town and Country Planning Board, 235 Queen Street, Melbourne at the office of the Council of the City of Croydon at Croydon, and when available, at the Office of Titles, Melbourne, and at the Central Plan Office of the Department of Crown Lands and Survey, Melbourne.

W. H. CRAIG, Secretary  
Town and Country Planning Board

*Town and Country Planning Act 1961*

**CITY OF FRANKSTON PLANNING SCHEME**

AMENDMENT No. 22, 1979

*Notice of Approval*

In pursuance of the powers conferred by the *Town and Country Planning Act 1961*, the Governor in Council on 20 May 1980, approved a planning scheme entitled the City of Frankston Planning Scheme, Amendment No. 22, 1979 in respect of the municipal district of the City of Frankston and such planning scheme comes into operation on the date this Notice of Approval is published in the *Government Gazette*.

A copy of the planning scheme as approved may be inspected, free of charge, during office hours at the office of the Town and Country Planning Board, 235 Queen Street, Melbourne at the office of the Council of the City of Frankston at Frankston, and when available, at the Office of Titles, Melbourne, and at the Central Plan Office of the Department of Crown Lands and Survey, Melbourne.

W. H. CRAIG, Secretary  
Town and Country Planning Board

*Town and Country Planning Act 1961*

**CITY OF HORSHAM PLANNING SCHEME**

AMENDMENT No. 52, 1979

*Notice of Approval*

In pursuance of the powers conferred by the *Town and Country Planning Act 1961*, the Governor in Council on 20 May 1980, approved a planning scheme entitled the City of Horsham Planning Scheme, Amendment No. 52, 1979, in respect of part of the municipal district of the City of Horsham and such planning scheme comes into operation on the date this Notice of Approval is published in the *Government Gazette*.

A copy of the planning scheme as approved may be inspected, free of charge, during office hours at the office of the Town and Country Planning Board, 235 Queen Street, Melbourne at the office of the Council of the City of Horsham at Horsham, and when available, at the Office of Titles, Melbourne, and at the Central Plan Office of the Department of Crown Lands and Survey, Melbourne.

W. H. CRAIG, Secretary  
Town and Country Planning Board

*Town and Country Planning Act 1961*  
CITY OF HORSHAM PLANNING SCHEME 1973  
AMENDMENT No. 54, 1979  
*Notice of Approval*

In pursuance of the powers conferred by the *Town and Country Planning Act 1961*, the Governor in Council on 20 May 1980, approved a planning scheme entitled the City of Horsham Planning Scheme 1973, Amendment No. 54, 1979, in respect of part of the municipal district of the City of Horsham and such planning scheme comes into operation on the date this Notice of Approval is published in the *Government Gazette*.

A copy of the planning scheme as approved may be inspected, free of charge, during office hours at the office of the Town and Country Planning Board, 235 Queen Street, Melbourne at the office of the Council of the City of Horsham at Horsham, and when available, at the Office of Titles, Melbourne, and at the Central Plan Office of the Department of Crown Lands and Survey, Melbourne.

W. H. CRAIG, Secretary  
Town and Country Planning Board

*Town and Country Planning Act 1961*  
LATROBE VALLEY SUB-REGIONAL PLANNING SCHEME  
REVOCATION No. 21  
*Notice of Revocation*

In pursuance of the provisions of section 32 of the *Town and Country Planning Act 1961* the Governor in Council on 20 May 1980, made an Order revoking the Latrobe Valley Sub-Regional Planning Scheme in so far as it applies to the area included in the City of Traralgon by gazettal of 5 September 1979, and more particularly described on the maps annexed to the said Order.

A copy of the Order may be inspected during office hours at the office of the Town and Country Planning Board, 235 Queen Street, Melbourne, and at the office of the Council of the City of Traralgon at Traralgon.

W. H. CRAIG, Secretary  
Town and Country Planning Board

*Town and Country Planning Act 1961*  
CITY OF MARYBOROUGH PLANNING SCHEME 1962  
AMENDMENT No. 7, 1979  
*Notice of Approval*

In pursuance of the powers conferred by the *Town and Country Planning Act 1961*, the Governor in Council on 20 May 1980, approved a planning scheme entitled the City of Maryborough Planning Scheme 1962, Amendment No. 7, 1979 in respect of part of the municipal district of the City of Maryborough and such planning scheme comes into operation on the date this Notice of Approval is published in the *Government Gazette*.

A copy of the planning scheme as approved may be inspected, free of charge, during office hours at the office of the Town and Country Planning Board, 235 Queen Street, Melbourne at the office of the Council of the City of Maryborough at Maryborough, and when available, at the Office of Titles, Melbourne, and at the Central Plan Office of the Department of Crown Lands and Survey, Melbourne.

W. H. CRAIG, Secretary  
Town and Country Planning Board

*Town and Country Planning Act 1961*  
MELBOURNE METROPOLITAN PLANNING SCHEME  
AMENDMENT No. 144  
*Notice of Approval*

In pursuance of the powers conferred by the *Town and Country Planning Act 1961*, the Governor in Council on 20 May 1980 approved a planning scheme entitled the Melbourne Metropolitan Planning Scheme, Amendment No. 144, in respect of part of the municipal district of the Shire of Whittlesea and such planning scheme comes into operation on the date this Notice of Approval is published in the *Government Gazette*.

A copy of the planning scheme as approved may be inspected, free of charge, during office hours at the office of the Town and Country Planning Board, 235 Queen Street, Melbourne, at the office of the Melbourne and Metropolitan Board of Works at 625 Little Collins Street, Melbourne, and when available, at the Office of Titles, Melbourne, and at the Central Plan Office of the Department of Crown Lands and Survey, Melbourne.

W. H. CRAIG, Secretary  
Town and Country Planning Board

*Town and Country Planning Act 1961*  
CITY OF MILDURA PLANNING SCHEME  
AMENDMENT No. 22, 1977  
*Notice of Approval*

In pursuance of the powers conferred by the *Town and Country Planning Act 1961*, the Governor in Council on 20 May 1980 approved a planning scheme entitled the City of Mildura Planning Scheme, Amendment No. 22, 1977, in respect of part of the municipal district of the City of Mildura, and such planning scheme comes into operation on the date this Notice of Approval is published in the *Government Gazette*.

A copy of the planning scheme as approved may be inspected, free of charge, during office hours at the office of the Town and Country Planning Board, 235 Queen Street, Melbourne, at the office of the Council of the City of Mildura at Mildura, and when available, at the Office of Titles, Melbourne, and at the Central Plan Office of the Department of Crown Lands and Survey, Melbourne.

W. H. CRAIG, Secretary  
Town and Country Planning Board

*Town and Country Planning Act 1961*  
OCEAN ROAD PLANNING SCHEME  
AMENDMENT No. 15  
*Notice of Amendment*

In pursuance of the powers conferred by sub-section 6 of section 32 of the *Town and Country Planning Act 1961*, the Governor in Council, on 20 May 1980 amended the Ocean Road Planning Scheme to incorporate provisions relating to cluster developments into the planning scheme in respect of the Residential A and Residential B zones.

A copy of the amendment may be inspected during office hours at the office of the Town and Country Planning Board, 235 Queen Street, Melbourne, at the office of the Council of the Shire of Otway at Beech Forest, and when available, at the office of Titles, Melbourne, and at the Central Plan Office of the Department of Crown Lands and Survey, Melbourne.

W. H. CRAIG, Secretary  
Town and Country Planning Board

*Town and Country Planning Act 1961*  
CITY OF TRARALGON PLANNING SCHEME  
AMENDMENT No. 17, 1979  
*Notice of Amendment*

In pursuance of the powers conferred by sub-section 6 of section 32 of the *Town and Country Planning Act 1961*, the Governor in Council, on 20 May 1980 amended the City of Traralgon Planning Scheme to include the area within the City of Traralgon as from 5 September 1979 and to zone the land residential development and secondary roads as shown on the planning scheme map.

A copy of the amendment may be inspected during office hours at the office of the Town and Country Planning Board, 235 Queen Street, Melbourne, at the office of the Council of the City of Traralgon at Traralgon, and when available, at the Office of Titles, Melbourne, and at the Central Plan Office of the Department of Crown Lands and Survey, Melbourne.

W. H. CRAIG, Secretary  
Town and Country Planning Board

Town and Country Planning Act 1961  
TOWN OF BAIRNSDALE PLANNING SCHEME

AMENDMENT No. 23, 1979

Notice of Approval

In pursuance of the powers conferred by the Town and Country Planning Act 1961, the Governor in Council on 20 May 1980, approved a planning scheme entitled, the Town of Bairnsdale Planning Scheme, Amendment No. 23, 1979, in respect of part of the municipal district of the Town of Bairnsdale and such planning scheme comes into operation on the date this Notice of Approval is published in the Government Gazette.

A copy of the planning scheme as approved may be inspected, free of charge, during office hours at the office of the Town and Country Planning Board, 235 Queen Street, Melbourne, at the office of the Council of the Town of Bairnsdale at Bairnsdale, and when available, at the Office of Titles, Melbourne, and at the Central Plan Office of the Department of Crown Lands and Survey, Melbourne.

W. H. CRAIG, Secretary  
Town and Country Planning Board

Town and Country Planning Act 1961  
TOWN OF KYABRAM PLANNING SCHEME 1963

AMENDMENT No. 22, 1979

Notice of Approval

In pursuance of the powers conferred by the Town and Country Planning Act 1961, the Governor in Council on 20 May 1980, approved a planning scheme entitled the Town of Kyabram Planning Scheme 1963, Amendment No. 22, 1979, in respect of part of the municipal district of the Town of Kyabram and such planning scheme comes into operation on the date this Notice of Approval is published in the Government Gazette.

A copy of the planning scheme as approved may be inspected, free of charge, during office hours at the office of the Town and Country Planning Board, 235 Queen Street, Melbourne, at the office of the Council of the Town of Kyabram at Kyabram, and when available, at the Office of Titles, Melbourne, and at the Central Plan Office of the Department of Crown Lands and Survey, Melbourne.

W. H. CRAIG, Secretary  
Town and Country Planning Board

Town and Country Planning Act 1961  
TOWN OF KYABRAM PLANNING SCHEME 1963

AMENDMENT No. 23, 1979

Notice of Approval

In pursuance of the powers conferred by the Town and Country Planning Act 1961, the Governor in Council on 20 May 1980, approved a planning scheme entitled the Town of Kyabram Planning Scheme 1963, Amendment No. 23, 1979, in respect of part of the municipal district of the Town of Kyabram and such planning scheme comes into operation on the date this Notice of Approval is published in the Government Gazette.

A copy of the planning scheme as approved may be inspected, free of charge, during office hours at the office of the Town and Country Planning Board, 235 Queen Street, Melbourne, at the office of the Council of the Town of Kyabram at Kyabram, and when available, at the Office of Titles, Melbourne, and at the Central Plan Office of the Department of Crown Lands and Survey, Melbourne.

W. H. CRAIG, Secretary  
Town and Country Planning Board

Town and Country Planning Act 1961  
SHIRE OF BENALLA PLANNING SCHEME

AMENDMENT No. 11

Notice of Amendment

In pursuance of the powers conferred by sub-section 6 of section 32 of the Town and Country Planning Act 1961, the Governor in Council, on 20 May 1980, amended the Shire of Benalla Planning Scheme to enable the creation of allotments of less than the minimum size to provide a site for an existing house in the Rural B and Rural C zones.

A copy of the amendment may be inspected during office hours at the office of the Town and Country Planning Board, 235 Queen Street, Melbourne, at the office of the Council of the Shire of Benalla at Benalla, and when available at the Office of Titles, Melbourne and at the Central Plan Office of the Department of Crown Lands and Survey, Melbourne.

W. H. CRAIG, Secretary  
Town and Country Planning Board

Town and Country Planning Act 1961  
SHIRE OF BUNINYONG PLANNING SCHEME

AMENDMENT No. 11

Notice of Amendment

In pursuance of the powers conferred by sub-section 6 of section 32 of the Town and Country Planning Act 1961, the Governor in Council, on 20 May 1980, amended the Shire of Buninyong Planning Scheme to insert "Public Utility Services" as a column 2 consent use in the table of uses applicable to the Forest Zone.

A copy of the amendment may be inspected during office hours at the office of the Town and Country Planning Board, 235 Queen Street, Melbourne, at the office of the Council of the Shire of Buninyong at Buninyong, and when available at the Office of Titles, Melbourne and at the Central Plan Office of the Department of Crown Land and Survey, Melbourne.

W. H. CRAIG, Secretary  
Town and Country Planning Board

Town and Country Planning Act 1961  
SHIRE OF CRANBOURNE (WESTERN PORT) PLANNING SCHEME

AMENDMENT No. 10

Notice of Amendment

In pursuance of the powers conferred by sub-section 6 of section 32 of the Town and Country Planning Act 1961, the Governor in Council, on 20 May 1980, amended the Shire of Cranbourne (Western Port) Planning Scheme to insert a new definition for "Minor Utility Installation" in the ordinance.

A copy of the amendment may be inspected during office hours at the office of the Town and Country Planning Board, 235 Queen Street, Melbourne, at the office of the Council of the Shire of Cranbourne at Cranbourne, and when available at the Office of Titles, Melbourne and at the Central Plan Office of the Department of Crown Lands and Survey, Melbourne.

W. H. CRAIG, Secretary  
Town and Country Planning Board

Town and Country Planning Act 1961  
SHIRE OF FLINDERS PLANNING SCHEME 1962

AMENDMENT No. 122, 1979

Notice of Approval

In pursuance of the powers conferred by the Town and Country Planning Act 1961, the Governor in Council on 20 May 1980, approved a planning scheme entitled the Shire of Flinders Planning Scheme 1962, Amendment No. 122, 1979, in respect of part of the municipal district of the Shire of Flinders and such planning scheme comes into operation on the date this Notice of Approval is published in the Government Gazette.



A copy of the planning scheme as approved may be inspected, free of charge, during office hours at the office of the Town and Country Planning Board, 235 Queen Street, Melbourne; at the office of the Council of the Shire of Flinders at Rosebud, and when available, at the Office of Titles, Melbourne, and at the Central Plan Office of the Department of Crown Lands and Survey, Melbourne.

W. H. CRAIG, Secretary  
Town and Country Planning Board

*Town and Country Planning Act 1961*  
SHIRE OF FLINDERS PLANNING SCHEME 1962  
AMENDMENT No. 126, 1979

*Notice of Approval*

In pursuance of the powers conferred by the *Town and Country Planning Act 1961*, the Governor in Council on 20 May 1980, approved a planning scheme entitled the *Shire of Flinders Planning Scheme 1962, Amendment No. 126, 1979*, in respect of part of the municipal district of the Shire of Flinders and such planning scheme comes into operation on the date this Notice of Approval is published in the *Government Gazette*.

A copy of the planning scheme as approved may be inspected, free of charge, during office hours at the office of the Town and Country Planning Board, 235 Queen Street, Melbourne; at the office of the Council of the Shire of Flinders at Rosebud, and when available, at the Office of Titles, Melbourne, and at the Central Plan Office of the Department of Crown Lands and Survey, Melbourne.

W. H. CRAIG, Secretary  
Town and Country Planning Board

*Town and Country Planning Act 1961*  
SHIRE OF HEALESVILLE

INTERIM DEVELOPMENT ORDER

AMENDMENT No. 14

*Notice of Amendment*

In pursuance of the powers conferred by section 26 of the *Town and Country Planning Act 1961*, the Governor in Council on 20 May 1980 amended the *Shire of Healesville Interim Development Order* to permit the subdivision of lot 11, lodged plan 98679, Badger Creek Road, Healesville, into two allotments.

A copy of the amendment may be inspected during office hours at the office of the Town and Country Planning Board, 235 Queen Street, Melbourne, and at the office of the Council of the Shire of Healesville, at Healesville.

W. H. CRAIG, Secretary  
Town and Country Planning Board

*Town and Country Planning Act 1961*  
SHIRE OF LILLYDALE PLANNING SCHEME 1958  
AMENDMENT No. 122, 1980

*Notice of Amendment*

In pursuance of the powers conferred by sub-section 6 of section 32 of the *Town and Country Planning Act 1961*, the Governor in Council on 20 May 1980 amended the *Shire of Lillydale Planning Scheme* to rezone approximately 12 hectares of land located between Hartley Road and Dudley Road, Wonga Park, from Existing Public Purposes (2)—School to Residential Development zone.

A copy of the amendment may be inspected during office hours at the office of the Town and Country Planning Board, 235 Queen Street, Melbourne, at the office of the Council of the Shire of Lillydale at Lillydale, and when available at the Office of Titles, Melbourne, and at the Central Plan Office of the Department of Crown Lands and Survey, Melbourne.

W. H. CRAIG, Secretary  
Town and Country Planning Board

*Town and Country Planning Act 1961*  
SHIRE OF OTWAY (COASTAL AREAS)

INTERIM DEVELOPMENT ORDER

AMENDMENT No. 1

*Notice of Amendment*

In pursuance of the powers conferred by section 26 of the *Town and Country Planning Act 1961*, the Governor in Council on 20 May 1980 amended the *Shire of Otway (Coastal Areas) Interim Development Order* to include a new Forest Residential Zone and rezone approximately 70 hectares near Cape Otway to provide for the construction of 15 houses pursuant to the *Cluster Titles Act*.

A copy of the amendment may be inspected during office hours at the office of the Town and Country Planning Board, 235 Queen Street, Melbourne, and at the office of the Council of the Shire of Otway at Beech Forest.

W. H. CRAIG, Secretary  
Town and Country Planning Board

*Town and Country Planning Act 1961*  
SHIRE OF SWAN HILL

INTERIM DEVELOPMENT ORDER

AMENDMENT No. 1

*Notice of Amendment*

In pursuance of the powers conferred by section 26 of the *Town and Country Planning Act 1961*, the Governor in Council on 20 May 1980 amended the *Shire of Swan Hill Interim Development Order* to enable the subdivision of part of Crown Allotment 33, section C, Parish of Tynnyder into three allotments of 0.24 ha, 0.67 ha and 0.88 ha, and part of Crown Allotment 147b, Parish of Piangil into two allotments of 1.27 ha and 1.37 ha.

A copy of the amendment may be inspected during office hours at the office of the Town and Country Planning Board, 235 Queen Street, Melbourne and at the office of the Council of the Shire of Swan Hill at Swan Hill.

W. H. CRAIG, Secretary  
Town and Country Planning Board

*Town and Country Planning Act 1961*  
SHIRE OF TRARALGON INTERIM DEVELOPMENT ORDER

REVOCATION No. 1

*Notice of Revocation*

In pursuance of the powers conferred by section 26 of the *Town and Country Planning Act 1961*, the Governor in Council on 20 May 1980 revoked the *Shire of Traralgon Interim Development Order* in respect of the area now included in the *City of Traralgon* by gazettal of 5 September 1979.

A copy of the revocation may be inspected during office hours at the office of the Town and Country Planning Board, 235 Queen Street, Melbourne, and at the office of the Council of the City of Traralgon at Traralgon.

W. H. CRAIG, Secretary  
Town and Country Planning Board

*Town and Country Planning Act 1961*  
SHIRE OF UPPER YARRA PLANNING SCHEME

INTERIM DEVELOPMENT ORDER

AMENDMENT No. 54

*Notice of Amendment*

In pursuance of the powers conferred by section 26 of the *Town and Country Planning Act 1961*, the Governor in Council on 20 May 1980 amended the *Shire of Upper Yarra Interim Development Order* to introduce three new rural zones with accompanying minimum subdivision size provisions.

A copy of the amendment may be inspected during office hours at the office of the Town and Country Planning Board, 235 Queen Street, Melbourne, and at the office of the Council of Shire of Upper Yarra at Yarra Junction.

W. H. CRAIG, Secretary  
Town and Country Planning Board

## APPOINTMENTS AND RESIGNATIONS

### APPOINTMENTS

His Excellency the Governor of the State of Victoria, by and with the advice of the Executive Council thereof, has, by Orders made on 20 May 1980, been pleased to make the under-mentioned appointments, viz.:-

#### DEPARTMENT OF COMMUNITY WELFARE SERVICES

##### *Honorary Probation Officers*

JOHN MCGILTON BRACE, 18 Hamilton Street, Niddrie,  
ANN PATRICIA BUGELLY, 135 Park Street, Moonee Ponds,  
ERIC DIXON, 3 Marjorie Avenue, Belmont, Geelong,  
JOY IRIS FERRIS, Unit 3/31 Warr's Road, Maribyrnong,  
BRENDA JOYCE LEE, 78 Fosters Road, Keilor Park,  
BARBARA DOREEN MACKINNON-CLARK, 13A Thomson  
Street, Essendon,  
RAYMOND ALFRED ALWAY, 20 South Street, Belmont,  
BETTY GWENYTH BARKER, 82 Elgin Street, Sale,  
KERRIE ANNE FAIRWEATHER, 78 Goold Street, Bairnsdale,  
TREVOR BARRY McMURRICH, Flat 4, 2 Matilda Street,  
Belmont, Geelong,  
PAUL RODNEY MACKINNON-CLARK, 13A Thompson Street,  
Essendon,  
MERIANNE CAROLINE MAHER, 42 Dinah Parade, East  
Keilor,  
MARK SIDNEY ROSEVEAR, Factory Road, care of Post  
Office, Cororooke, and  
MICHAEL BERNARD RYAN, 162 Waiora Road, McLeod,  
to be Honorary Probation Officers, for all Adult and Child-  
ren's Courts in Victoria pursuant to the provisions of  
section 507 (2) of the *Crimes Act 1958*, and section 9 of  
the *Children's Court Act 1973*.

#### HEALTH COMMISSION

##### *Trustee of Public Cemetery*

JAMES CASTLES  
to be a Trustee of the Ararat Public Cemetery pursuant  
to section 3 (1) of the *Cemeteries Act 1958*.

#### LAW DEPARTMENT

##### *Justices of the Peace*

HAROLD RODNEY LOMAX, 14-18 Pioneer Street, Foster,  
and  
JAMES RALSTON SMITH, 2 Vaughan Avenue, Ferntree  
Gully,  
to be Justices of the Peace for the State of Victoria.

##### *Commissioners for Taking Declarations, &c.*

BRIAN GERALD AHIN, 1064 Dandenong Road, Carnegie,  
KATHRYN ANN ANDREWS, 153 Flinders Lane, Melbourne,  
VINCENT BENVENUTO, 191 Buckley Street, Essendon,  
DONALD JAMES CAMPBELL, 96A Poath Road, Hughesdale,  
KENNETH GORDON CLARK-KENNEDY, 5 Coonil Crescent,  
Malvern,  
DOUGLAS ROBERT CROUCH,  
DAVID LYLE MORSE,  
WARREN BRUCE SHEARD,  
301 Flinders Lane, Melbourne,  
ANTHONY TURNER CURTAIN, 63 Yarra Street, Geelong,  
FREDERICK JAMES FIELD, 706 Lorimer Street, Port Mel-  
bourne,  
HAROLD ARTHUR HANCOCK, 18 Yarragon Road, Leon-  
gatha,  
MARY VERONICA HUSSEY, 104 Studley Park Road, Kew,  
RICHARD GRAHAM INCE, 22-32 Moore Street, Moe,  
BARBARA MARY MCNEILL, McMahons Road, Frankston,  
BRUCE IAN MARSHALL, corner Malop and Moorabool  
Streets, Geelong, and  
FRANK MURLEY RICHARDS, 68 Cyclamen Avenue, Altona  
North,  
to be Commissioners for taking Declarations and Affidavits  
under the *Evidence Act 1958*.

#### *Assistant Registrar of County Court*

IAN ROBERT SIGG, Clerk of Courts, Class "CC-2",  
to be Assistant Registrar at Wodonga for the County  
Court at Wangaratta, vice P. Maloney, resigned.

TOM FORRISTAL

Clerk of the Executive Council

At the Executive Council Chamber  
Melbourne, 20 May 1980

#### *Filled Milk Act 1958*

##### APPOINTMENT OF ADVISORY COMMITTEE

I, Ian Winton Smith, being the responsible Minister  
of the Crown for the time being administering the *Filled  
Milk Act 1958*, hereby appoint the under-mentioned persons  
to be members of the Advisory Committee in accordance  
with section 3 of the said Act for the period 1 July 1980  
to 30 June 1981.

ROBERT STIRLING BELCHER, Chairman of the Committee,  
who is a representative of the Department of Agri-  
culture.

DESMOND DUDLEY COOPER who is a representative of  
the Victorian Dairy Industry Authority.

THOMAS GLOVER MADDISON who is a person nominated  
by the governing body for Victoria of the Australian  
Medical Association.

JOHN RICHARD PYLE who is a person nominated by the  
governing body for Victoria of the Processed Milk  
Manufacturers Association of Australia Limited.

HENRY GEORGE MOSELY who is a person deemed to be  
representative of dairy farmers in Victoria.

Dated at Melbourne, 13 May 1980

IAN SMITH

Minister of Agriculture

#### *Liquor Control Act 1968*

##### APPOINTMENT OF LICENSING INSPECTORS

Whereas on 6 February 1980, Sinclair Imrie Miller, the  
Chief Commissioner of Police for the State of Victoria acting  
pursuant to the power vested in him by Section 6A of the *Police  
Regulation Act 1958* delegated to me the undersigned David John  
Swanson being an Assistant Commissioner of Police for the said  
State and the person referred to in the said delegation all powers  
and functions vested in him by the *Liquor Control Act 1968*, from  
6 February 1980, now therefore I do hereby appoint the following  
Officers of Police as Licensing Inspectors for the Divisions of the  
Police Districts as shown :

Division Number	Police District	Rank and Name
1	Cheltenham	Inspector Maurice Edward William Stafferton (from 7.5.80 to 3.6.80)
4	Cheltenham	Inspector Arthur Charles Roberts (from 11.5.80 to 7.6.80)
2	Dandenong	Inspector Bruce James Warne (from 11.5.80 to 31.5.80)
1	Loddon	Inspector Adrian Knox Booth (from 28.4.80 to 1.6.80)
		D. J. SWANSON
22.5.1980		Assistant Commissioner (Services)

#### *Imitation Milk Act 1969*

##### APPOINTMENT OF ADVISORY COMMITTEE

I, Ian Winton Smith, being the responsible Minister  
of the Crown for the time being administering the *Imita-  
tion Milk Act 1969*, hereby appoint the under-mentioned  
persons to be members of the Advisory Committee in  
accordance with section 4 of the said Act for the period  
1 July 1980 to 30 June 1981.

ROBERT STIRLING BELCHER, Chairman of the Committee,  
who is a representative of the Department of Agri-  
culture.

DESMOND DUDLEY COOPER who is a representative of  
the Victorian Dairy Industry Authority.

THOMAS GLOVER MADDISON who is a person nominated by the governing body for Victoria of the Australian Medical Association.

JOHN RICHARD PYLE who is a person nominated by the governing body for Victoria of the Processed Milk Manufacturers Association of Australia Limited.

HENRY GEORGE MOSELY who is a person deemed to be representative of dairy farmers in Victoria.

Dated at Melbourne, 13 May 1980

IAN SMITH  
Minister of Agriculture

**REVOCATION OF APPOINTMENTS**

LAW DEPARTMENT

His Excellency the Governor of the State of Victoria by and with the advice of the Executive Council thereof has by Order made on 20 May 1980, revoked the appointments of MARKO BAGARIC, ALEXANDER EDWARD BANNING, LEON GORR, JOHN NORMAN HAYWOOD and HAROLD LEIGH JOSEPH as Commissioners for taking Declarations and Affidavits under the Evidence Act 1958.

TOM FORRISTAL  
Clerk of the Executive Council

At the Executive Council Chamber  
Melbourne, 20 May 1980

**RESIGNATIONS**

His Excellency the Governor of the State of Victoria, by and with the advice of the Executive Council thereof, has, by Order made on 20 May 1980 accepted the resignations of the persons named hereunder of the office mentioned, viz.:-

LAW DEPARTMENT  
*Justices of the Peace*

NEAL HEWITT HARVIE,  
FREDERICK THEODORE LUCKMAN, and  
ARCHIBALD NICOL MCCALLUM,  
as Justices of the Peace for the State of Victoria.

*Commissioners for Taking Declarations, &c.*

LENARD DOWELL GRATTIDGE, and  
BERNARD NEIL SHELLEY,  
as Commissioners for taking Declarations and Affidavits under the Evidence Act 1958.

DEPARTMENT OF COMMUNITY WELFARE SERVICES  
*Honorary Probation Officers*

MARGARET COATES BROWNING,  
ALICE CAMERON,  
JUDITH CORDINER,  
LESLIE WILLIAM CUNLIFFE,  
JOHN IGNATIUS DOHERTY,  
MARY GIBLIN,  
JOHN SINCLAIR LAMPARD,  
JOHN FRANCIS MEEHAN,  
JOHN RODNEY MITCHELL,  
JOHN STUART MACLEOD MURRAY,  
KERRY NEWTON,  
MARGARET JUNE O'CONNOR,  
PETER O'CONNOR,  
(Mts) RUTH HELEN PARRAMORE,  
ROWAN RIELLY,  
JACK LAVER SACH,  
JOAN MARGARET STEPHENS,  
IAN FYFE THOMAS,  
KEVIN GEORGE TOCKNELL,  
JAMES LAWRENCE TURNER,  
ANNE MARIA VAUGHAN, and  
KEVIN ZERVOS,  
as Honorary Probation Officers pursuant to the provisions of section 507 (2) of the Crimes Act 1958, and section 9 of the Children's Court Act 1973, for all Adult and Children's Courts in Victoria.

TOM FORRISTAL  
Clerk of the Executive Council

At the Executive Council Chamber  
Melbourne, 20 May 1980

**ORDERS IN COUNCIL**

LOCAL GOVERNMENT ACT 1958

At the Executive Council Chamber, Melbourne, the  
twentieth day of May, 1980

PRESENT:

His Excellency the Governor of Victoria  
Mr Smith | Mr Maclellan

**MAKING OF TREE RESERVE—CITY OF MELBOURNE**

His Excellency the Governor of the State of Victoria, by and with the advice of the Executive Council thereof, in pursuance of the provisions of section 557 of the Local Government Act 1958 and in compliance with a request by the Council of the City of Melbourne, hereby directs that the land shown hatched on the plan hereunder being part of Lee Street, Carlton, shall be a Tree Reserve.

CITY OF MELBOURNE  
PARISH OF JIKA JIKA AT CARLTON  
COUNTY OF BOURKE

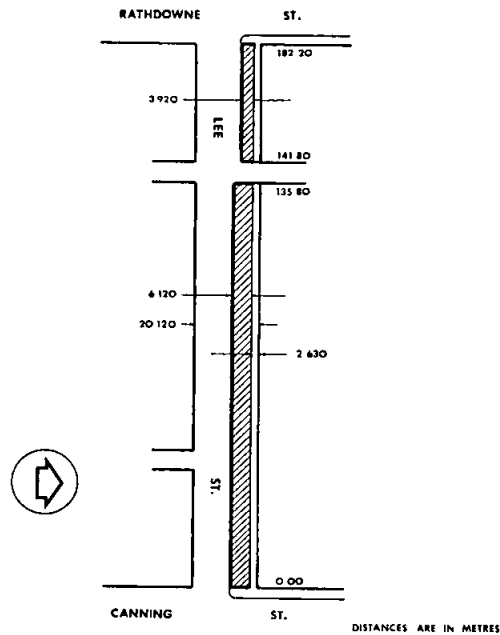

And the Honorable Digby Glen Crozier, Her Majesty's Minister for Local Government for the State of Victoria, shall give the necessary directions herein accordingly.

TOM FORRISTAL  
Clerk of the Executive Council

LOCAL GOVERNMENT ACT 1958

At the Executive Council Chamber, Melbourne, the twentieth day of May, 1980

PRESENT:

His Excellency the Governor of Victoria  
Mr Smith | Mr Maclellan

CONSENT TO VARIATION OF USE OF A RESERVE—  
CITY OF BOX HILL

Whereas pursuant to the provisions of section 569BA of the Local Government Act 1958 certain land being the Drainage Reserve on Plan of Subdivision No. 8629 lodged in the Office of Titles was vested in the Council of the City of Box Hill by Order published in the Government Gazette, No. 67, dated 8 August 1979 and the Council of the City of Box Hill is now of the opinion that the land is no longer required for the purpose for which it was reserved and has requested that consent be given to the use of the land for Drainage and Road Purposes.

And whereas the said Council:

- (a) has published in a newspaper generally circulating in the municipal district a notice describing the land and the proposal for the altered use thereof and stating that at the next ordinary meeting of the Council after the expiration of forty days after publication of the notice the Council would consider any objection to the proposal;
- (b) has served a copy of the said notice upon any other person whom the Council considered should be so served; and
- (c) has posted a similar notice upon the land in question.

And whereas written objections to the proposal have been received and the Council has taken into consideration such objections.

Now therefore, His Excellency the Governor of the State of Victoria, by and with the advice of the Executive Council thereof and in pursuance of the provisions of sub-section 2 of section 569BA of the Local Government Act 1958 hereby consents to the use of the land shown as the Drainage Reserve on Plan of Subdivision No. 8629 lodged in the Office of Titles and indicated by hachure on the plan hereunder for Drainage and Road Purposes.

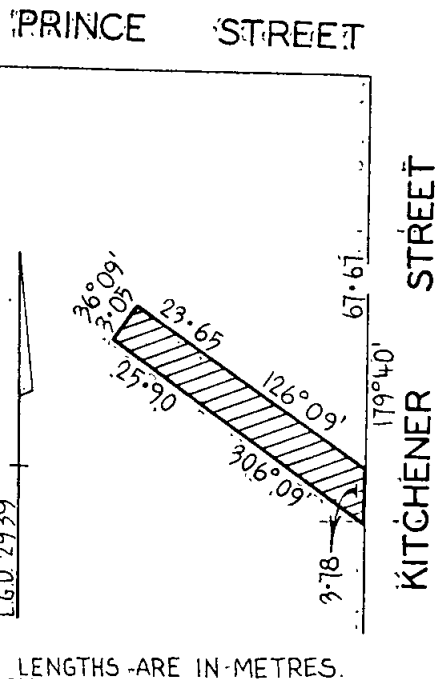

And the Honorable Digby Glen Crozier, Her Majesty's Minister for Local Government for the State of Victoria, shall give the necessary directions herein accordingly.

TOM FORRISTAL  
Clerk of the Executive Council

LOCAL GOVERNMENT ACT 1958

At the Executive Council Chamber, Melbourne, the twentieth day of May, 1980

PRESENT:

His Excellency the Governor of Victoria  
Mr Smith | Mr Maclellan

ROADS DISCONTINUED—CITY OF FOOTSCRAY

Whereas it is provided in section 528 (2) of the Local Government Act 1958, that where a road (whether or not a public highway but not being a road set out on land of the Crown) or any part thereof is not required for public use the Governor in Council on the request of the council of the municipality in which such road is situated made not less than one month after publishing in a newspaper generally circulating in the district and posting to the registered proprietor (if any) of the land and the owners and occupiers (if any) of lands abutting or immediately adjacent to the road notice of intention to make such a request may by Order published in the Government Gazette direct that such road or part shall be discontinued and thereupon such road or part shall be discontinued accordingly;

And whereas the Council of the City of Footscray has requested that the Governor in Council direct that part of a road off North Street, Footscray and that part of a road off Collins Street, Footscray be discontinued and not less than one month previously has published in a newspaper generally circulating in the district and posted to the registered proprietor of the land in the roads and to the owners and occupiers of lands abutting or immediately adjacent to the roads notice of intention to make such a request;

Now therefore, His Excellency the Governor of the State of Victoria, by and with the advice of the Executive Council thereof, hereby directs—

- (a) that the said parts of roads which are shown by hatching on the plans hereunder shall be discontinued;
- (b) that notwithstanding such discontinuance the Melbourne and Metropolitan Board of Works shall continue to have and possess the same right title power authority or interest in or in relation to the whole of the land shown by hatching on the said plans as it had or possessed prior to such discontinuance with respect to or in connection with any drains or pipes laid or erected in on or over such land for drainage or sewerage purposes; and

(c) that subject to any such right title power authority or interest, the land in the said parts of roads may be sold by the council of the City of Footscray by agreement.

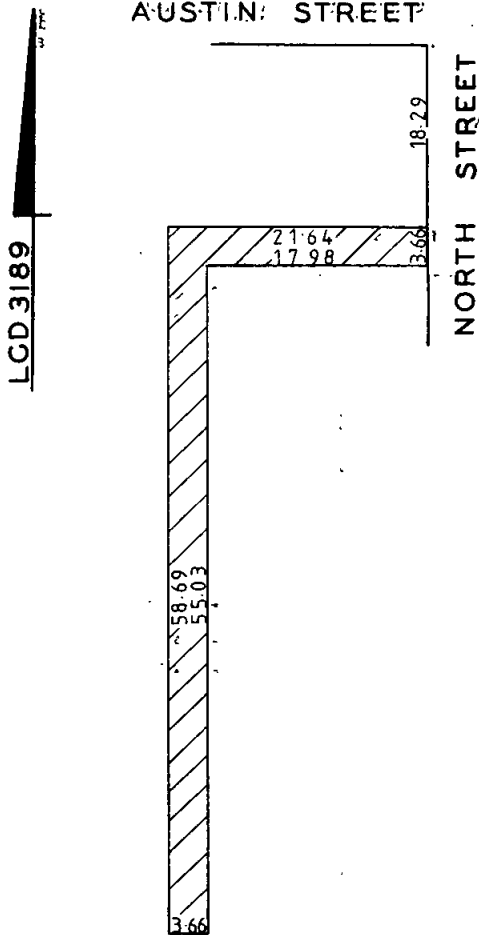

LENGTHS ARE IN METRES

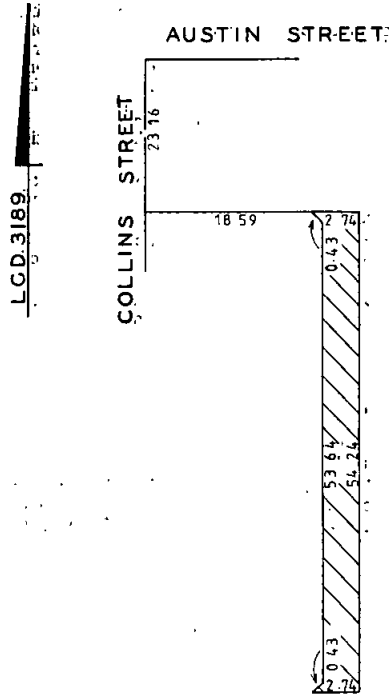

LENGTHS ARE IN METRES

And the Honorable Digby Glen Crozier, Her Majesty's Minister for Local Government for the State of Victoria, shall give the necessary directions herein accordingly.

TOM FORRISTAL  
Clerk of the Executive Council.

LOCAL GOVERNMENT ACT 1958

At the Executive Council Chamber, Melbourne, the twentieth day of May, 1980

PRESENT:

His Excellency the Governor of Victoria  
Mr Smith | Mr Maclellan

ROAD DISCONTINUED—CITY OF MELBOURNE

Whereas it is provided in section 528 (2) of the Local Government Act 1958, that where a road (whether or not a public highway, but not being a road set-out on land of the Crown) or any part thereof is not required for public use the Governor in Council on the request of the council of the municipality in which such road is situated made not less than one month after publishing in a newspaper generally circulating in the district and posting to the registered proprietor (if any) of the land and the owners and occupiers, (if any), of lands abutting or immediately adjacent to the road notice of intention to make such a request may by Order published in the Government Gazette direct that such road or part shall be discontinued and thereupon such road or part shall be discontinued accordingly;

And whereas the Council of the City of Melbourne has requested that the Governor in Council direct that part of a road off Little Bourke Street, Melbourne, known as Merrits Place be discontinued and not less than one month previously has published in a newspaper generally circulating in the district and posted to the registered proprietor of the land in the road and to the owners and occupiers of lands abutting or immediately adjacent to the road notice of intention to make such request;

Now therefore, His Excellency the Governor of the State of Victoria, by and with the advice of the Executive Council thereof, hereby directs—

- (a) that the said part of a road which is shown by hatching on the plan hereunder shall be discontinued;
- (b) that notwithstanding such discontinuance the Melbourne and Metropolitan Board of Works shall continue to have and possess the same right title power authority or interest in or in relation to the whole of the land shown by hatching on the said plan as it had or possessed prior to such discontinuance with respect to or in connection with any drains or pipes laid or erected in on or over such land for the purposes of drainage and sewerage; and
- (c) that, subject to any such right title power authority or interest the land in the said part of a road may be sold by the Council of the City of Melbourne by agreement.

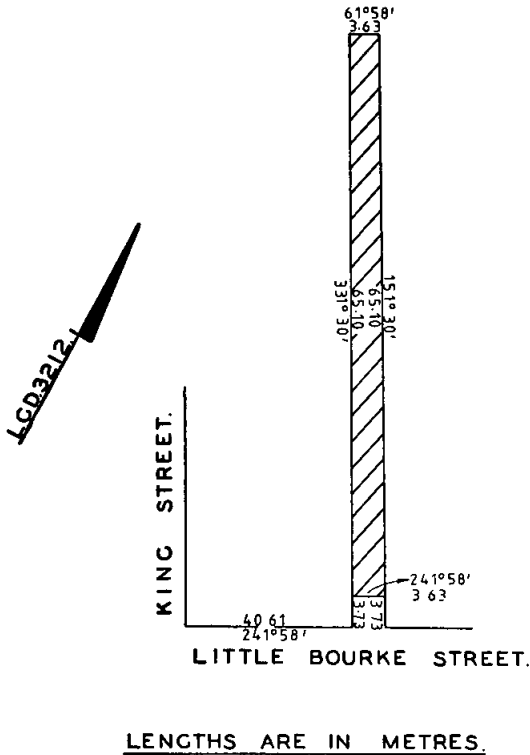

LOCAL GOVERNMENT ACT 1958

At the Executive Council Chamber, Melbourne, the twentieth day of May, 1980

PRESENT:

His Excellency the Governor of Victoria  
Mr Smith | Mr Maclellan

MAKING OF TREE RESERVE—CITY OF MELBOURNE

His Excellency the Governor of the State of Victoria, by and with the advice of the Executive Council thereof, in pursuance of the provisions of section 557 of the Local Government Act 1958 and in compliance with a request by the Council of the City of Melbourne, hereby directs that the land shown hatched on the plan hereunder being part of Chetwynd Street, North Melbourne, shall be a Tree Reserve.

CITY OF MELBOURNE  
PARISH OF JIKA JIKA AT NORTH MELBOURNE  
COUNTY OF BOURKE

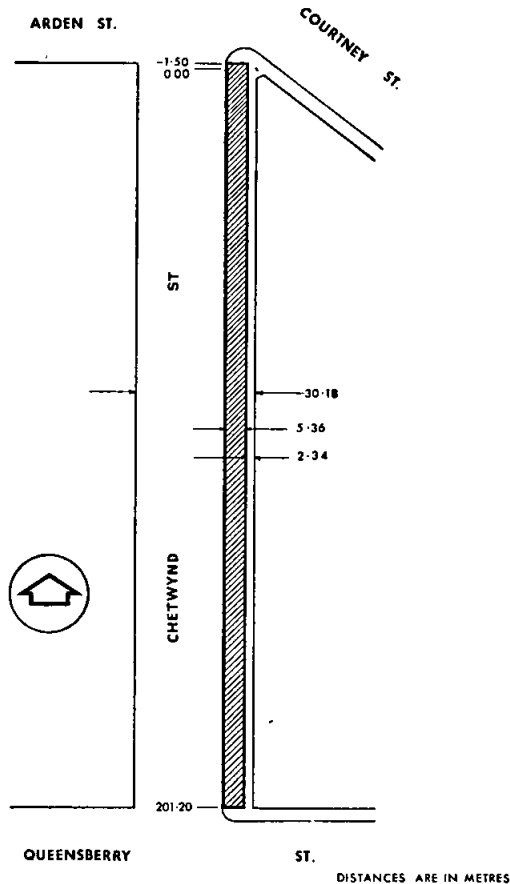

And the Honorable Digby Glen Crozier, Her Majesty's Minister for Local Government for the State of Victoria, shall give the necessary directions herein accordingly.

TOM FORRISTAL  
Clerk of the Executive Council

And the Honorable Digby Glen Crozier, Her Majesty's Minister for Local Government for the State of Victoria, shall give the necessary directions herein accordingly.

TOM FORRISTAL  
Clerk of the Executive Council

COUNTRY ROADS BOARD  
Act No. 6229

At the Executive Council Chamber, Melbourne, the  
twentieth day of May, 1980

PRESENT:

His Excellency the Governor of Victoria  
Mr Smith | Mr Maclellan

ORDER APPROVING OF LAND BEING ACQUIRED AND  
ROADS, DEVIATIONS OR WIDENING BEING MADE  
TOGETHER WITH ALL ANCILLARY WORKS  
REQUIRED TO BE EXECUTED IN CONJUNCTION  
THEREWITH

His Excellency the Governor of the State of Victoria, by  
and with the advice of the Executive Council thereof, being  
satisfied that there are funds legally available for acquiring  
the land, doth hereby approve the acquiring of the land  
described in the schedule hereunder and the making of  
new roads and deviations from and widenings of existing  
roads, together with all ancillary works required to be  
executed in conjunction therewith, referred to in the said  
schedule.

SCHEDULE  
State Highways

The land shown hatched on plan numbered G.P.15232  
hereunder required for the widening of the Maroondah  
Highway in the City of Camberwell and making of the  
widening thereon.

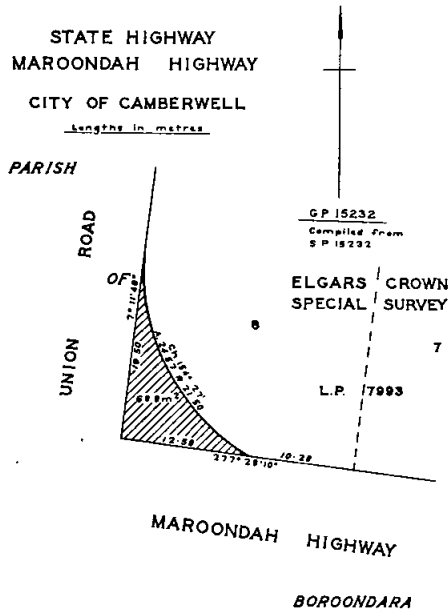

The land shown hatched on plan numbered G.P.15177  
hereunder required for the widening of the Sunraysia  
Highway in the Town of St. Arnaud and making of the  
widening's thereon.

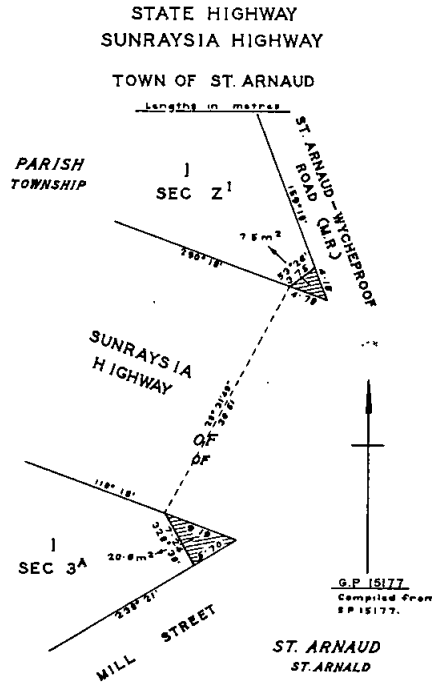

The land shown hatched on plan numbered G.P.15206  
hereunder required for the deviation from Walhalla Road in  
the Shire of Narracan and making of the deviation thereon.

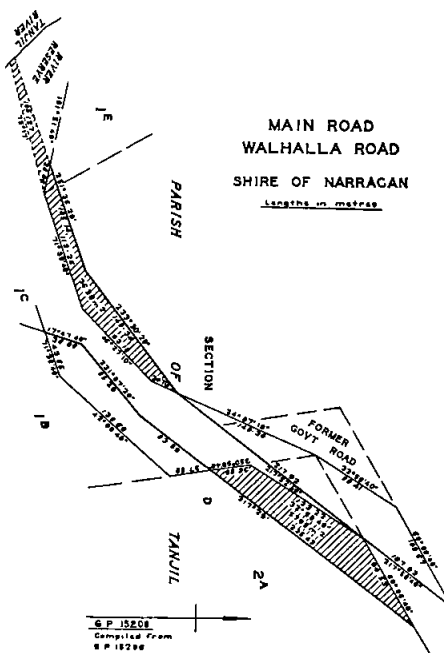

The land shown hatched on plan numbered G.P.15083 hereunder required for the widening of the Birregurra-Forrest Road in the Shire of Winchelsea and making of the widening thereon.

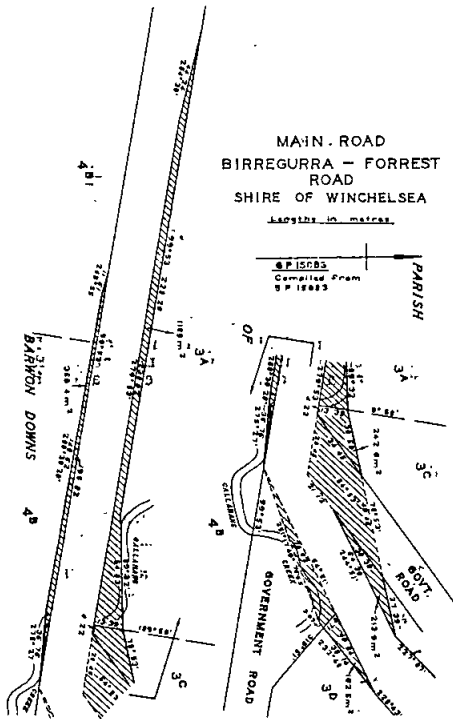

**Freeway**  
The land shown hatched on plan numbered G.P.15167 hereunder required for the making of a new freeway (Princes Freeway) in the Shire of Warragul.

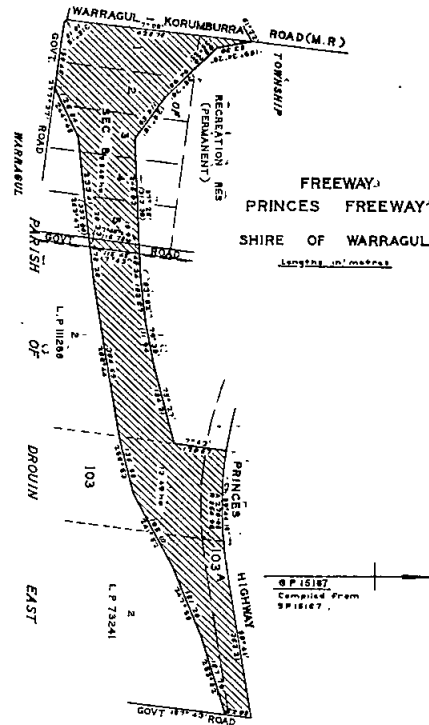

And the Honorable Robert Roy Cameron Maclellan, Her Majesty's Minister of Transport for the necessary directions herein accordingly.

TOM FORRISTAL  
Clerk of the Executive Council

COUNTRY ROADS ACT 1958  
Act No. 6229

At the Executive Council Chamber, Melbourne, the twentieth day of May, 1980

PRESENT:

His Excellency the Governor of Victoria  
Mr Smith | Mr Maclellan

ORDER CONFIRMING RESOLUTIONS OF THE COUNTRY ROADS BOARD.

His Excellency the Governor of the State of Victoria, by and with the advice of the Executive Council thereof, doth hereby, in pursuance of the provisions of the Country Roads Act 1958, confirm the resolutions of the Country Roads Board, the dates whereof and the terms of which are scheduled hereunder:

SCHEDULE  
Main Roads

Resolution dated the seventh day of May, One thousand nine hundred and eighty, made pursuant to section 18 of the Country Roads Act 1958, declaring the highway in the Shire of Kowree as shown hatched on plans numbered G.P.189P1 and G.P.1265P1 hereunder to be a main road (Booroopki-Frances Road) within the meaning and for the purposes of the said Act.



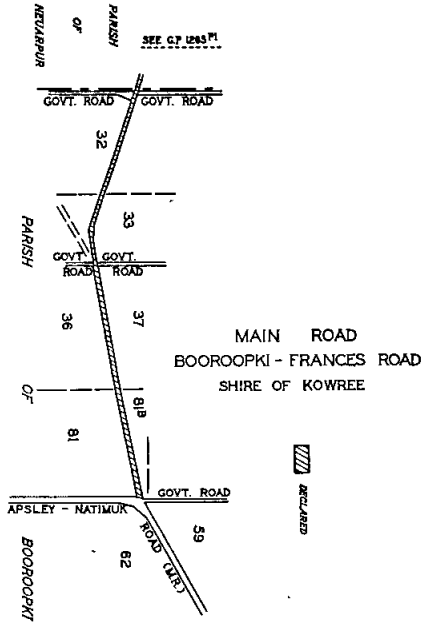

Resolution dated the seventh day of May, One thousand nine hundred and eighty, made pursuant to section 18 of the Country Roads Act 1958, rescinding the resolution passed by the Country Roads Board on the first day of August, One thousand nine hundred and twenty-seven and confirmed by an Order in Council published in the *Government Gazette* of the seventeenth day of August, One thousand nine hundred and twenty-seven on page 2507 declaring the highway to be a main road (Booroopki-Frances Road) in the Shire of Kowree so far as it relates to the part of the said main road indicated by cross hatching on plans numbered G.P.1265P2 and G.P.189P2 hereunder.

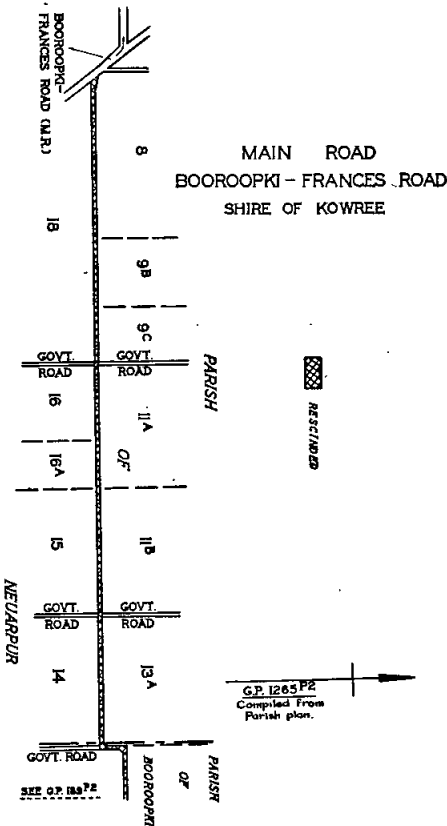
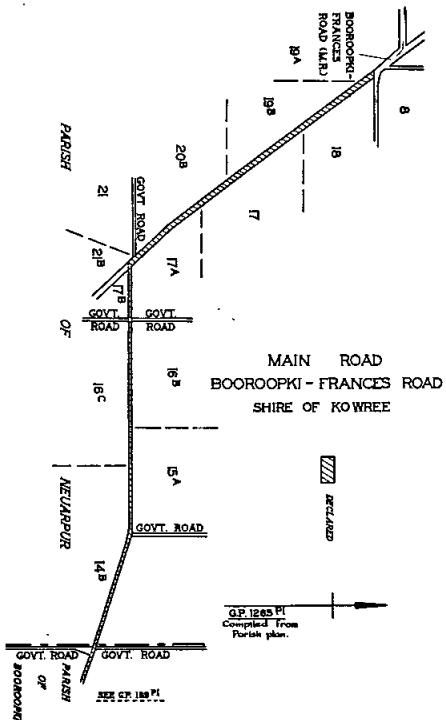

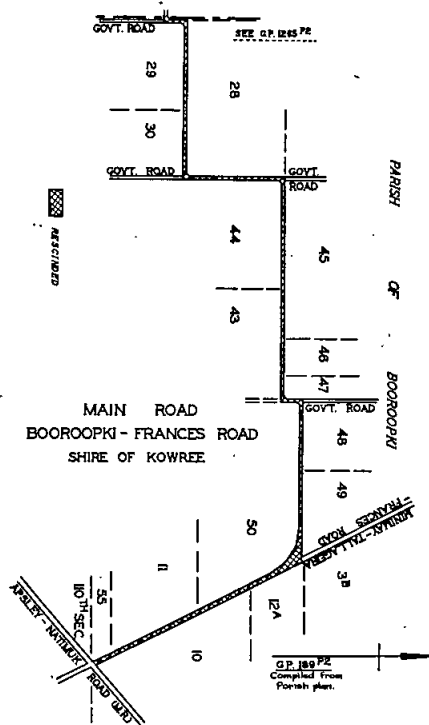

thousand nine hundred and fifty-nine on page 3106 declaring the highway to be a main road (Cobden-Warrnambool Road) in the Shire of Warrnambool so far as it relates to the part of the said main road indicated by cross hatching on plan numbered G.P.6673 hereunder.

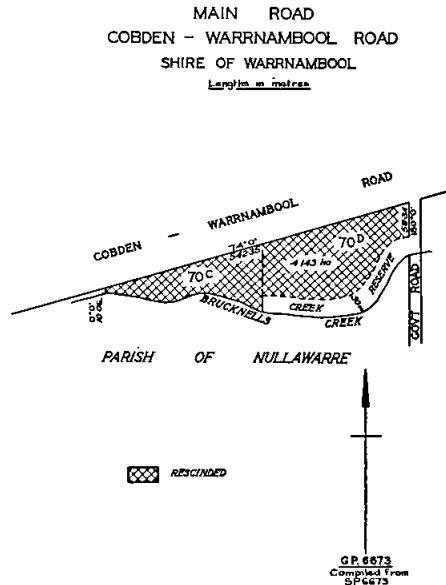

Resolution dated the seventh day of May, One thousand nine hundred and eighty, made pursuant to section 18 of the *Country Roads Act 1958*, rescinding the resolution passed by the Country Roads Board on the fifth day of October, One thousand nine hundred and fifty-nine and confirmed by an Order in Council published in the *Government Gazette* of the twenty-first day of October, One

And the Honorable Robert Roy Cameron Maclellan, Her Majesty's Minister of Transport for the State of Victoria, shall give the necessary directions herein accordingly.

TOM FORRISTAL  
Clerk of the Executive Council

*Marine Act 1958*

AMENDMENT TO PORT RULE APPLICABLE TO WESTERNPORT HARBOR SERVICES (RATES AND CHARGES)

At the Executive Council Chamber, Melbourne, the twentieth day of May, 1980

PRESENT:

His Excellency the Governor of Victoria  
Mr Smith | Mr Maclellan

PORT RULE No. 132

In pursuance of the powers conferred by Part II. of the *Marine Act 1958* and all other powers him thereunto enabling His Excellency the Governor of the State of Victoria, by and with the advice of the Executive Council thereof, amends Port Rule No. 132 dated 29 November 1977 as amended on 27 November 1979, as follows:

(1) Delete the proviso at the end of paragraph (A) of the Schedule to Clause 2.

(2) Delete the proviso at the end of paragraph (B) of the Schedule to Clause 2 and substitute the following:

"Provided that during the period between 1 June 1980 and 30 November 1980, both dates inclusive, the charges set forth in sub-paragraphs (B) (i) and

(ii) of this Schedule shall be reduced by 10 per cent., unless the Governor in Council determines otherwise."

(3) Delete the proviso at the end of paragraph (C) of the Schedule to Clause 2 and substitute the following:

"Provided that during the period between 1 June 1980 and 30 November 1980, both dates inclusive, the charges set forth in paragraph (C) of this Schedule shall be reduced by 30 per cent., unless the Governor in Council determines otherwise."

(4) Delete paragraph (D) of the Schedule to Clause 2 and substitute the following:

"(D) TELEPHONES

Every vessel to which a telephone is temporarily installed by the State shall pay a connection fee of \$90 and reimburse the State the cost of all trunk line calls."

(5) Delete paragraph (E) of the Schedule to Clause 2 and substitute the following:

"(E) GANGWAYS

Every vessel berthed at Crib Point jetties to which a State-owned gangway is provided, shall pay a fee of \$270 and in the case of a cancellation of an order, a fee of \$135."

And the Honorable Tom Austin, Her Majesty's Minister of Public Works for the State of Victoria, shall give the necessary directions herein accordingly.

TOM FORRISTAL  
Clerk of the Executive Council

CROWN LAND (RESERVES) ACT 1978

At the Executive Council Chamber, Melbourne, the twentieth day of May, 1980

PRESENT:

His Excellency the Governor of Victoria  
Mr Smith | Mr Maclellan

CROWN LANDS TEMPORARILY RESERVED

His Excellency the Governor of the State of Victoria, in the Commonwealth of Australia, by and with the advice of the Executive Council of the said State, pursuant to the provisions of sections 4 and 7 of the Crown Land (Reserves) Act 1978, and being of the opinion that the Crown lands concerned are required for the purposes respectively mentioned, doth hereby temporarily reserve and also except from occupation for mining purposes under any miner's right, the Crown lands hereinafter described, viz.:

**BOURKA**—For Conservation of an Area of Natural Interest, 32.38 hectares, being Crown allotment 45B, Parish of Bourka, as indicated by hatching on plan hereunder—(B.746<sup>(4)</sup>) (Rs.11012).

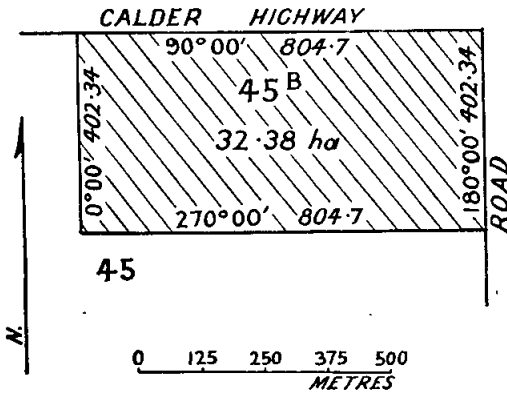

**MILDURA**—For Drainage, 8.093 hectares, being Crown allotment 4, section 111, Block F, Parish of Mildura, as indicated by hatching on plan hereunder—(M.556<sup>(14)</sup>) (Rs.10974).

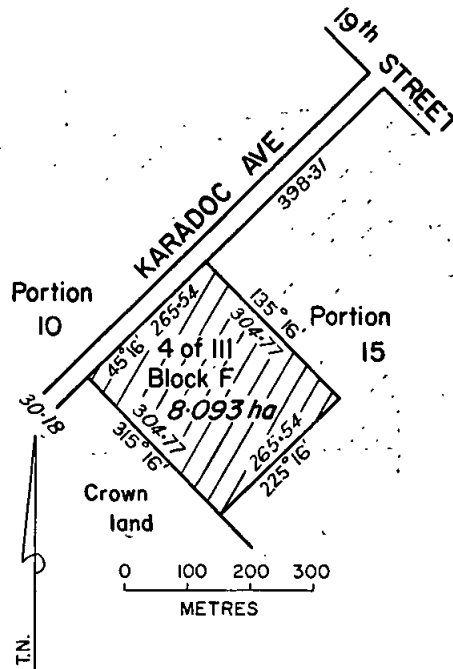

**MILDURA**—For Conservation of an Area of Natural Interest, 8.384 hectares, being Crown allotment 624, section B, Parish of Mildura, as indicated by hatching on plan hereunder—(M.556<sup>(17)</sup>) (Rs.11009).

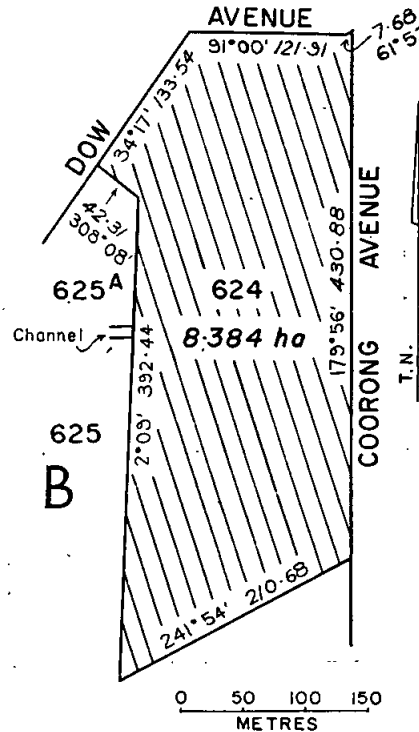

**DUNKELD**—For Water Supply, 644 square metres, being Crown allotment 96C, Parish of Dunkeld, as shown on Certified Plan No. 104491 lodged in the Central Plan Office—(D.142<sup>(1)</sup>) (Rs.8059).

**JIKA JIKA (FITZROY)**—For Public Buildings, 2447 square metres, being Crown allotment 72A, Parish of Jika Jika, as indicated by hatching on plan hereunder—(F.99<sup>(6)</sup>) (Rs.11000).

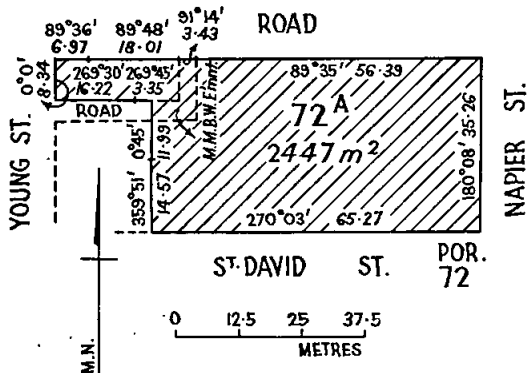

MILDURA—For Conservation of an Area of Natural Interest, 7.119 hectares, being Crown allotment 702, section B, Parish of Mildura, as indicated by hatching on plan hereunder—(M.556<sup>(1)</sup>) (Rs.11014).

OUYEN—For Conservation of an Area of Natural Interest, 24.28 hectares, being Crown allotment 12A, Parish of Ouyen, as indicated by hatching on plan hereunder—(O.22<sup>(6)</sup>) (Rs.11011).

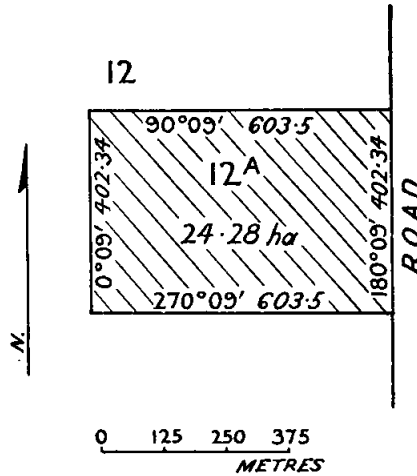
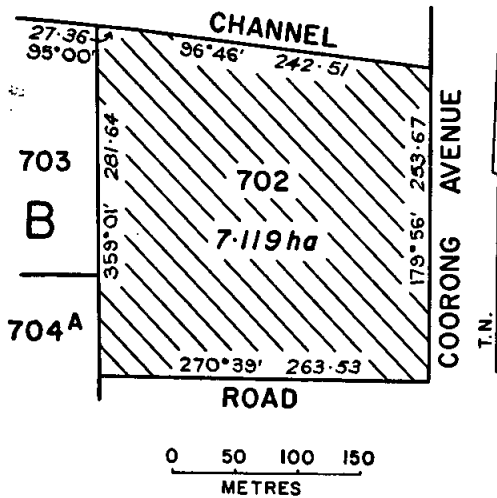

STAWELL—For Recreation and Drainage, 1.154 hectares, being Crown allotment 16, section 53, Parish of Stawell, as shown on Certified Plan No. 103433 lodged in the Central Plan Office—(Rs.10847).

And the Honorable William Vasey Houghton, Her Majesty's Minister of Lands for the State of Victoria, shall give the necessary directions herein accordingly.

TOM FORRISTAL  
Clerk of the Executive Council

MORANDING—For Conservation of an Area of Natural Interest, 4.3 hectares, more or less, being Crown allotment 170A, Parish of Moranding, as indicated by hatching on plan hereunder—(M.139<sup>(2)</sup>) (Rs.11016).

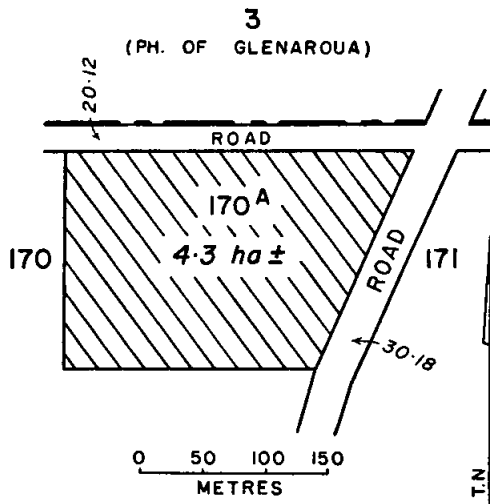

CROWN LAND (RESERVES) ACT 1978

At the Executive Council Chamber, Melbourne, the twentieth day of May, 1980

PRESENT:

His Excellency the Governor of Victoria  
Mr Smith | Mr Maclellan

CERTAIN RESERVED CROWN LANDS PLACED UNDER THE CONTROL AND MANAGEMENT OF THE DIRECTOR OF NATIONAL PARKS

His Excellency the Governor of the State of Victoria, in the Commonwealth of Australia, by and with the advice of the Executive Council of the said State, pursuant to the provisions of section 18 (1) of the *Crown Land (Reserves) Act 1978*, doth hereby place under the control and management of the Director of National Parks the reserved Crown lands hereinafter described, viz.:

GRACEDALE—The Crown land in the Parish of Gracedale being Crown allotment 4A, section B, temporarily reserved for the purposes of the National Parks Act by Order in Council of 22 April 1980 (see *Government Gazette* of 30 April 1980)—(Rs.10578).

And the Honorable William Vasey Houghton, Her Majesty's Minister of Lands for the State of Victoria, shall give the necessary directions herein accordingly.

TOM FORRISTAL  
Clerk of the Executive Council

CROWN LAND (RESERVES) ACT 1978

At the Executive Council Chamber, Melbourne, the twentieth day of May, 1980

PRESENT:

His Excellency the Governor of Victoria  
Mr Smith | Mr Maclellan

"WIRRAWAY PUBLIC RECREATION RESERVE" VESTED IN THE CITY OF MOE

His Excellency the Governor of the State of Victoria, in the Commonwealth of Australia, by and with the advice of the Executive Council of the said State, pursuant to the provisions of section 16 (1) of the *Crown Land (Reserves) Act 1978*, doth hereby direct that the Crown land in the Parish of Moe temporarily reserved as a site for Public Recreation by Order in Council of 10 May 1966 (see *Government Gazette* of 18 May 1966) and known as the "Wirraway Public Recreation Reserve", be vested in the municipality of the City of Moe on trust for the purposes for which the land has been reserved—(Rs.8605).

And the Honorable William Vasey Houghton, Her Majesty's Minister of Lands for the State of Victoria, shall give the necessary directions herein accordingly.

TOM FORRISTAL  
Clerk of the Executive Council

CROWN LAND (RESERVES) ACT 1978

At the Executive Council Chamber, Melbourne, the twentieth day of May, 1980

PRESENT:

His Excellency the Governor of Victoria  
Mr Smith | Mr Maclellan

REVOCATION OF TEMPORARY RESERVATIONS OF LANDS BY ORDERS IN COUNCIL

His Excellency the Governor of the State of Victoria, in the Commonwealth of Australia, by and with the advice of the Executive Council of the said State, pursuant to the provisions of section 10 of the *Crown Land (Reserves) Act 1978*, doth hereby revoke the temporary reservations of lands by Orders in Council hereinafter described, viz.:

**GRUYERE**—The temporary reservation by Order in Council of 28 December 1906 of 1.416 hectares of land in the Parish of Gruyere (adjoining Crown allotment 14A) as a site for Watering purposes—(Rs.11147).

**MOIRA**—The temporary reservation by Order in Council of 14 October 1958 of 8.093 hectares of land in the Parish of Moira (in section A) as a site for the purposes of the Forest Act, revoked as to part by Order of 17 December 1963, so far as the balance thereof containing 7.995 hectares, is concerned—(Rs.7639).

**WARRENBAYNE**—The temporary reservation by Order in Council of 24 September 1963 of 2.428 hectares of land in the Parish of Warrenbayne as a site for Public Recreation, so far only as the portion thereof containing 1452 square metres, as shown on Certified Plan No. 104427 lodged in the Central Plan Office, is concerned—(Rs.8265).

And the Honorable William Vasey Houghton, Her Majesty's Minister of Lands for the State of Victoria, shall give the necessary directions herein accordingly.

TOM FORRISTAL  
Clerk of the Executive Council

LAND ACT 1958

At the Executive Council Chamber, Melbourne, the twentieth day of May, 1980

PRESENT:

His Excellency the Governor of Victoria  
Mr Smith | Mr Maclellan

UNUSED ROADS CLOSED

His Excellency the Governor of the State of Victoria, in the Commonwealth of Australia, by and with the advice of the Executive Council of the said State, pursuant to the provisions of section 349 of the *Land Act 1958*, and with the concurrence in writing of the council of the municipality concerned and that of any adjoining land owners, doth hereby close the unused roads hereinafter described, viz.:

Municipal District of the City of Ararat, Township of Ararat, being the road indicated by hatching on plan hereunder—(A.148\*) (J.28328).

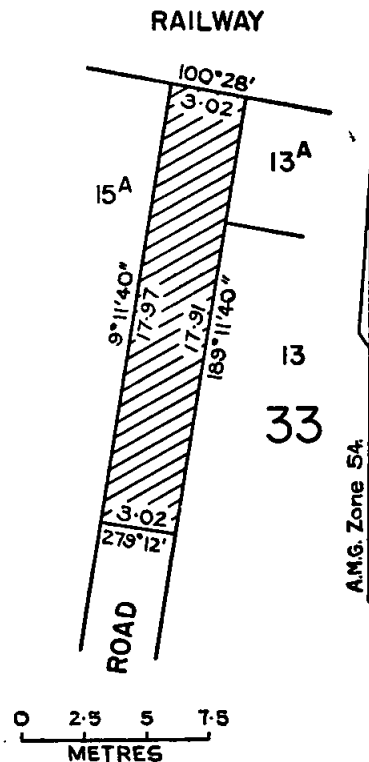

Municipal District of the City of Frankston, Township of Frankston, being the road indicated by hatching on plan hereunder—(F.86(4) (Rs.2591).

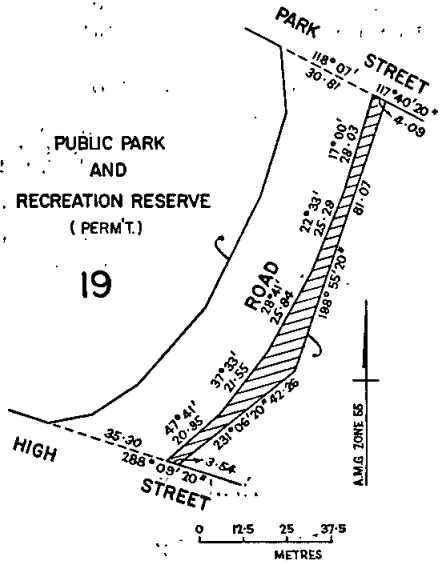

Municipal District of the Town of Stawell, Parish of Stawell, being the road indicated by hatching on plan hereunder—(S.329(15) (L.4-1066).

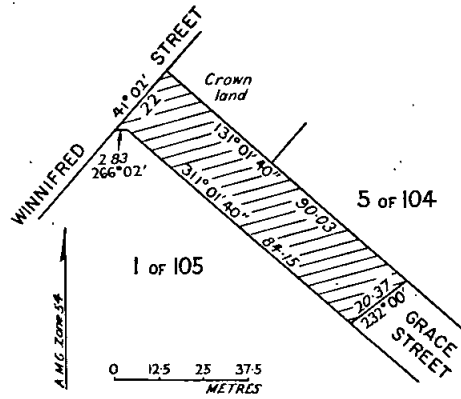

Municipal District of the Shire of Heytesbury, Township of Cobden, being the road indicated by hatching on plan hereunder—(C.353(2) (Rs.9708).

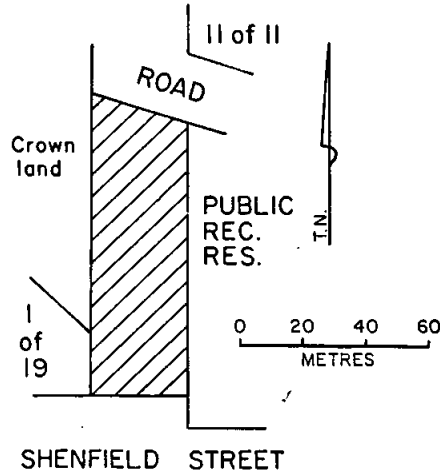

Municipal District of the City of Melbourne, City of Melbourne, being the road indicated by hatching on plan hereunder—(M.314(9) (Rs.4330).

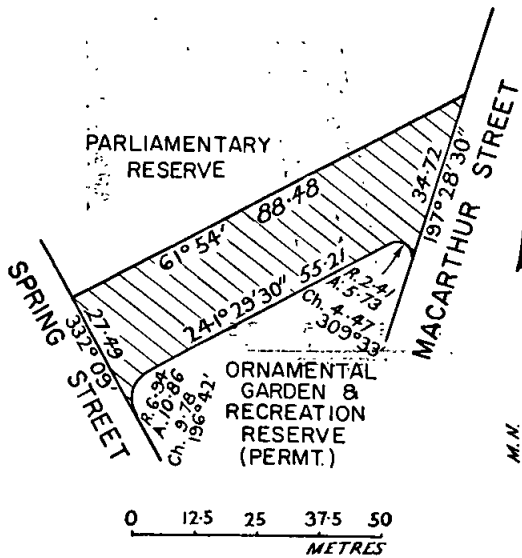

Municipal District of the Shire of Swan Hill, Township of Goschen, being the road indicated by hatching on plan hereunder—(G.231(8) (010994/130).

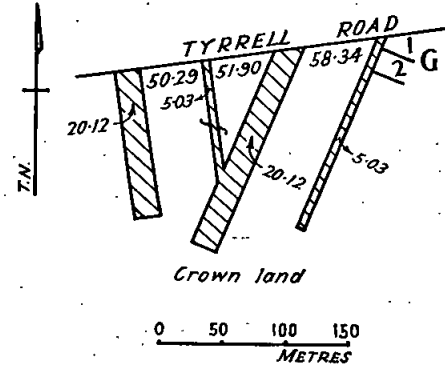

Municipal District of the Shire of Euroa, Parish of Euroa, being the road indicated by hatching on plan hereunder—(E.82<sup>(1)</sup>) (L.7-2235).

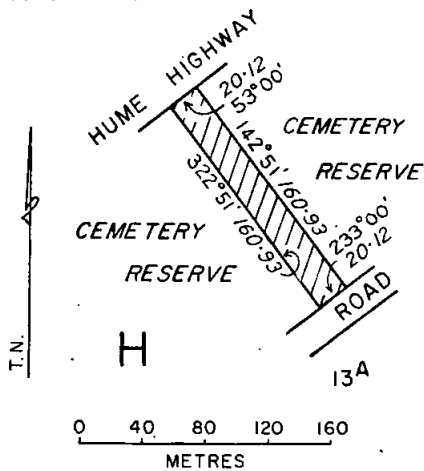

And the Honorable William Vasey Houghton, Her Majesty's Minister of Lands for the State of Victoria, shall give the necessary directions herein accordingly.

TOM FORRISTAL  
Clerk of the Executive Council

LAND ACT 1958

At the Executive Council Chamber, Melbourne, the twentieth day of May, 1980

PRESENT:

His Excellency the Governor of Victoria  
Mr Smith | Mr Maclellan

His Excellency the Governor of the State of Victoria, by and with the advice of the Executive Council thereof, doth by this Order made pursuant to section 22A (2) of

PATRIOTIC FUNDS ACT 1958

At the Executive Council Chamber, Melbourne, the twentieth day of May, 1980

PRESENT:

His Excellency the Governor of Victoria  
Mr Smith | Mr Maclellan

SANCTION OF TRANSFER OF PORTION OF THE R.S.L. WIDOWS AND WIDOWED MOTHERS' TRUST PATRIOTIC FUND No. B.96 TO THE MAYOR, COUNCILLORS AND CITIZENS OF THE CITY OF HEIDELBERG

Whereas:

I. Sub-section (1) of section 12A of the *Patriotic Funds Act 1958* provides *inter alia*, that where in the opinion of the Trustees of a patriotic fund (not being a patriotic fund administered by the Patriotic Funds Council of Victoria) it would more successfully accomplish the purposes for which the fund was established if any portion of the patriotic fund were transferred to a municipality exercising or proposing to exercise any power for the relief, assistance or support of any class of persons in special need of help, the trustees may with the sanction of the Governor in Council transfer any portion of the patriotic fund to the municipality to be applied in the exercise of the power upon such trusts as are specified

the *Land Act 1958* vest in the Mayor, Councillors and Citizens of the City of Geelong the land comprising 3.087 hectares being land in the Parish of Corio shown by hatching on plan annexed hereto—(C.272<sup>(2)</sup>) (L.1-1433).

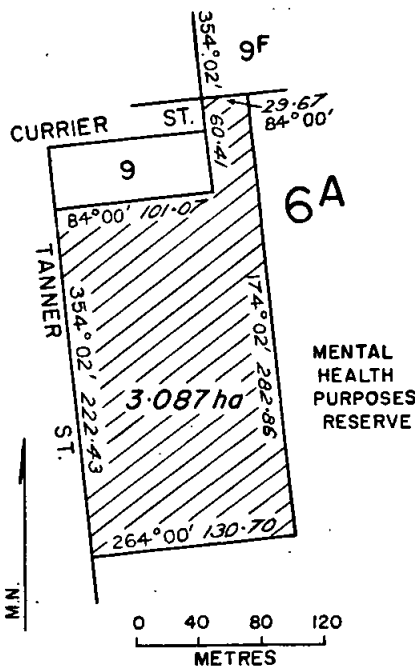

And the Honorable William Vasey Houghton, Her Majesty's Minister of Lands for the State of Victoria, shall give the necessary directions herein accordingly.

TOM FORRISTAL  
Clerk of the Executive Council

by the Governor in Council whereupon the portion of the patriotic fund shall vest in the municipality to be held and applied by it accordingly.

II. The R.S.L. Widows and Widowed Mothers' Trust Patriotic Fund No. B.96 (hereinafter called "the Fund") operates in pursuance of an Act of Parliament of the State of Victoria cited as the *R.S.L. Widows and Widowed Mothers' Trust Patriotic Fund Act 1964* and is a patriotic fund of the kind hereinbefore referred to.

III. The Mayor, Councillors and Citizens of the City of Heidelberg (hereinafter called "the Municipality") exercises powers pursuant to the provisions of the *Local Government Act 1958* to provide social services for the benefit of the people of the municipality.

IV. The trustees of the Fund have signified their opinion that it would more successfully accomplish the purposes for which the Fund was established if an amount of \$40 000 were transferred to the said Municipality.

Now therefore, His Excellency the Governor of the State of Victoria, by and with the advice of the Executive Council thereof, hereby sanctions the transfer by the trustees of the Fund to the Municipality of an amount of \$40 000 from the Fund to be held by the Municipality upon the following trusts:

1. To apply the said amount towards the operating costs of an institution for the elderly established by the Municipality at Waterdale Road, Heidelberg (hereinafter called "the Heidelberg Elderly Citizens' Village") which in addition to providing accommodation for the elderly provides an ongoing programme of care and other assistance.

2. To return to the trustees of the Fund the said amount (and any income received therefrom) if the Municipality is unable to give effect to these trusts within two years from the date of transfer of the said amount or within such further time as may be allowed by the said trustees.

3. To keep the Heidelberg Elderly Citizens' Village fully insured and take all necessary steps to ensure that any requirements arising under the law of the Commonwealth relating to social services and social security or under any relevant law of the State of Victoria are complied with in respect thereof.

4. To make eight beds in the Heidelberg Elderly Citizens' Village available in perpetuity for widows or widowed mothers of ex-servicemen nominated by the trustees of the Fund (hereinafter called "the Trust") upon the following conditions:

- (a) The Trust shall have all rights to nominate eight widows or widowed mothers of ex-servicemen as soon as beds are available for occupation at the Heidelberg Elderly Citizens' Village.
- (b) When a nominated person dies or vacates a bed the Trust shall have the right to nominate a qualified person to take the place vacated but if at any time the Trust is unable to nominate a person to fill the vacancy within a reasonable time the Municipality may accept any person to fill the vacancy but to the intent that a bed will be made available as soon as reasonably possible after a person is so nominated.
- (c) The Municipality shall advise the Trust of the date of admission and the date of discharge of any nominated person as soon as possible after the date of such admission or discharge.
- (d) The Municipality shall not be obliged to accept any nominated person who does not comply with the ordinary conditions for admission or undergo any interview or examination ordinarily required for admission.
- (e) Any fees and charges to be paid to the Municipality in respect of any nominated person shall be agreed upon between the nominated person and the Municipality.
- (f) The procedure shall be followed in perpetuity.

And the Honorable Haddon Storey, Her Majesty's Attorney-General for the State of Victoria, shall give the necessary directions herein accordingly.

TOM FORRISTAL  
Clerk of the Executive Council

#### VICTORIA LAW FOUNDATION ACT 1978

At the Executive Council Chamber, Melbourne, the twentieth day of May, 1980

PRESENT:

His Excellency the Governor of Victoria  
Mr Smith | Mr Maclellan

#### APPOINTMENT OF A MEMBER OF THE VICTORIA LAW FOUNDATION

In pursuance of the provisions of section 4 of the *Victoria Law Foundation Act 1978*, His Excellency the Governor of the State of Victoria, by and with the advice of the Executive Council thereof, doth by this Order appoint Daryl Michael Dawson, Q.C., being a nominee of the Chief Justice, to be a member of the Victoria Law Foundation for the period of five years commencing on 20 May 1980.

And the Honorable Haddon Storey, Her Majesty's Attorney-General for the State of Victoria, shall give the necessary directions herein accordingly.

TOM FORRISTAL  
Clerk of the Executive Council

#### MELBOURNE AND METROPOLITAN TRAMWAYS ACT 1958, No. 6311

At the Executive Council Chamber, Melbourne, the twentieth day of May, 1980

PRESENT:

His Excellency the Governor of Victoria  
Mr Smith | Mr Maclellan

Whereas His Excellency the Governor of the State of Victoria, by and with the advice of the Executive Council thereof, has this day consented pursuant to the provisions of section 28 of the *Melbourne and Metropolitan Tramways Act 1958*, to the Melbourne and Metropolitan Tramways Board raising by way of a loan an amount not exceeding Two hundred thousand dollars (\$200 000): And whereas His Excellency the Governor is satisfied that a sufficient proportion of the loan to be so raised will fall due and be repaid in each year during the currency of the proposed loan: Now therefore it is directed pursuant to the provisions of section 28 (6) of the said Act, that it shall not be necessary to provide a sinking fund in connection with such loan.

And the Honorable Lindsay Hamilton Simpson Thompson, Her Majesty's Treasurer for the State of Victoria, shall give the necessary directions herein accordingly.

TOM FORRISTAL  
Clerk of the Executive Council

#### BENALLA WATERWORKS TRUST

At the Executive Council Chamber, Melbourne, the twentieth day of May, 1980

PRESENT:

His Excellency the Governor of Victoria  
Mr Smith | Mr Maclellan

#### EXTENT OF WATERWORKS DISTRICT INCREASED

Under the powers conferred by the Water Act and all other powers enabling him in that behalf, His Excellency the Governor of the State of Victoria, by and with the advice of the Executive Council of the said State, doth hereby declare, order and direct that the extent of the Waterworks District of the Benalla Waterworks Trust be increased by adding to the same the land shown by red colour on the plan approved by the Governor in Council by and with this Order and deposited in the office of the State Rivers and Water Supply Commission, Melbourne (Corr. No. 78/1281/70) and as on and from the date hereof the extent of such District shall be and be deemed to be increased accordingly.

And the Honorable Frederick James Granter, Her Majesty's Minister of Water Supply for the State of Victoria, shall give the necessary directions herein accordingly.

TOM FORRISTAL  
Clerk of the Executive Council

#### WATER ACT 1958

At the Executive Council Chamber, Melbourne, the twentieth day of May, 1980

PRESENT:

His Excellency the Governor of Victoria  
Mr Smith | Mr Maclellan

#### GOULBURN-MURRAY IRRIGATION DISTRICT—DISTRICT EXTENDED COHUNA IRRIGATION AREA—BOUNDARIES VARIED

Under the powers conferred by the *Water Act 1958* and all other powers enabling him in that behalf, His Excellency the Governor of the State of Victoria, with the advice of



the Executive Council of the said State, on the recommendation of the State Rivers and Water Supply Commission, doth hereby declare, order and direct that the Goulburn-Murray Irrigation District be extended and the boundaries of the Cohuna Irrigation Area be varied by adding to the said District and Area the lands shown by blue colour on three plans approved by the Governor in Council and deposited in the office of the State Rivers and Water Supply Commission at 590 Orrong Road, Armadale (Corr. Nos. 63/5042, 65/4076, 65/4077, 65/4270 and 72/1609) and as on and from 1 July 1980, such District shall be deemed to be so extended and the boundaries of such Area shall be so varied.

And the Honorable Frederick James Granter, Her Majesty's Minister of Water Supply for the State of Victoria, shall give the necessary directions herein accordingly.

TOM FORRISTAL  
Clerk of the Executive Council

#### INVERLOCH WATERWORKS TRUST

At the Executive Council Chamber, Melbourne, the  
twentieth day of May, 1980

PRESENT:

His Excellency the Governor of Victoria  
Mr Smith | Mr Maclellan

#### EXTENT OF WATERWORKS AND URBAN DISTRICTS INCREASED

Under the powers conferred by the Water Act and all other powers enabling him in that behalf, His Excellency the Governor of the State of Victoria, by and with the advice of the Executive Council of the said State, doth hereby declare, order and direct that the extent of the Waterworks and Urban Districts of the Inverloch Waterworks Trust be increased by adding to the same the lands shown by red and brown borders respectively on the plan approved by the Governor in Council and deposited in the office of the State Rivers and Water Supply Commission, Melbourne (Corr. No. 74/959/95) and as on and from the date hereof, the extent of such districts shall be and be deemed to be increased accordingly.

And the Honorable Frederick James Granter, Her Majesty's Minister of Water Supply for the State of Victoria, shall give the necessary directions herein accordingly.

TOM FORRISTAL  
Clerk of the Executive Council

#### FIRST MILDURA IRRIGATION TRUST MILDURA URBAN WATER TRUST

At the Executive Council Chamber, Melbourne, the  
twentieth day of May, 1980

PRESENT:

His Excellency the Governor of Victoria  
Mr Smith | Mr Maclellan

#### SEVERENCE OF PORTION OF THE FIRST MILDURA IRRIGATION TRUST DISTRICT AND ANNEXATION TO THE MILDURA URBAN WATER TRUST DISTRICT

Under the powers conferred by the Mildura Irrigation and Water Trusts Act and all other powers enabling him in that behalf, His Excellency the Governor of the State of Victoria, by and with the advice of the Executive Council of the said State, doth hereby declare, order and direct that as on and from the date hereof the lands shown by red colour on the plans marked "A", "B" and "C" approved by the Governor in Council and deposited in the office of the State Rivers and Water Supply Commission, Melbourne (Corr. No. 59/2164/171) shall be severed from the District of the First Mildura Irrigation Trust and annexed to the District of the Mildura Urban Water Trust.

And the Honorable Frederick James Granter, Her Majesty's Minister of Water Supply for the State of Victoria, shall give the necessary directions herein accordingly.

TOM FORRISTAL  
Clerk of the Executive Council

#### MOUNT BEAUTY SEWERAGE AUTHORITY

At the Executive Council Chamber, Melbourne, the  
twentieth day of May, 1980

PRESENT:

His Excellency the Governor of Victoria  
Mr Smith | Mr Maclellan

#### EXTENT OF SEWERAGE DISTRICT INCREASED

Under the powers conferred by the Sewerage Districts Act and all other powers enabling him in that behalf, His Excellency the Governor of the State of Victoria, by and with the advice of the Executive Council of the said State, doth hereby declare, order and direct that the extent of the Sewerage District of the Mount Beauty Sewerage Authority be increased by adding thereto the four areas shown by red border on the plan approved by the Governor in Council, by and with this Order and deposited in the office of the State Rivers and Water Supply Commission, Melbourne (Corr. No. 78/10/46) and as on and from the date hereof the extent of such District shall be and be deemed to be increased accordingly.

And the Honorable Frederick James Granter, Her Majesty's Minister of Water Supply for the State of Victoria, shall give the necessary directions herein accordingly.

TOM FORRISTAL  
Clerk of the Executive Council

#### TOORA SEWERAGE AUTHORITY

At the Executive Council Chamber, Melbourne, the  
twentieth day of May, 1980

PRESENT:

His Excellency the Governor of Victoria  
Mr Smith | Mr Maclellan

#### APPROVAL OF SITE OF PIPELINES, ADDITIONAL TREATMENT WORKS AREA AND ACQUISITION OF LAND AND EASEMENTS

Under the powers conferred by the Sewerage Districts Act and all other powers enabling him in that behalf, His Excellency the Governor of the State of Victoria, by and with the advice of the Executive Council of the said State, doth hereby approve of—

- (a) the site of the pipelines and additional treatment works area required by the Toora Sewerage Authority as shown by red and yellow colours respectively on the plan approved by the Governor in Council by and with this Order and deposited in the office of the State Rivers and Water Supply Commission, Melbourne (Corr. No. 59/1423/161); and
- (b) the acquisition of the land required for the treatment works and the acquisition of the necessary easements over the pipelines.

And the Honorable Frederick James Granter, Her Majesty's Minister of Water Supply for the State of Victoria, shall give the necessary directions herein accordingly.

TOM FORRISTAL  
Clerk of the Executive Council

## SUPERANNUATION ACT 1958

At the Executive Council Chamber, Melbourne, the  
twentieth day of May, 1980

PRESENT:

His Excellency the Governor of Victoria  
Mr Smith | Mr Maclellan

Pursuant to the powers conferred by the provisions of paragraph (ja) of sub-section (1) of section 3 of the Superannuation Act 1958, His Excellency the Governor of the State of Victoria, by and with the advice of the Executive Council thereof, doth by this Order declare that the provisions of the Superannuation Act shall apply to the officers named in the schedule set out hereunder.

## SCHEDULE

LAWRANCE, LYNETTE KAY, Ballarat College of Advanced Education.  
CLIFFORD, JOAN AILEEN, State College of Victoria at Burwood.  
LARIN, NORBETT MARTIN, Footscray Institute of Technology.  
JONES, SANDRA BERNADETTE, Preston Institute of Technology.  
DODD, FREDERICK CHARLES HINDLEY, Small Business Development Corporation.

And the Honorable Lindsay Hamilton Simpson Thompson, Her Majesty's Treasurer for the State of Victoria, shall give the necessary directions herein accordingly.

TOM FORRISTAL  
Clerk of the Executive Council

## KYABRAM WATER AUTHORITY

At the Executive Council Chamber, Melbourne, the  
twenty-seventh day of May, 1980

PRESENT:

His Excellency the Governor of Victoria  
Mr Haddon Storey | Mr Crozier  
Mr Ramsay

## CONSENT TO BORROWING \$7000

Under the powers conferred by the Water Act and all other powers enabling him in that behalf, His Excellency the Governor of the State of Victoria, by and with the advice of the Executive Council of the said State, hereby consents to the Kyabram Water Authority borrowing the sum of Seven thousand dollars (\$7000) to meet the cost of water supply works.

And the Honorable Frederick James Granter, Her Majesty's Minister of Water Supply for the State of Victoria, shall give the necessary directions herein accordingly.

TOM FORRISTAL  
Clerk of the Executive Council

## LEONGATHA WATERWORKS TRUST

At the Executive Council Chamber, Melbourne, the  
twenty-seventh day of May, 1980

PRESENT:

His Excellency the Governor of Victoria  
Mr Haddon Storey | Mr Crozier  
Mr Ramsay

## CONSENT TO BORROWING \$200 000

Under the powers conferred by the Water Act and all other powers enabling him in that behalf, His Excellency the Governor of the State of Victoria, by and with the advice of the Executive Council of the said State, hereby

consents to the Leongatha Waterworks Trust borrowing the sum of Two hundred thousand dollars (\$200 000) to meet the cost of water supply works.

And the Honorable Frederick James Granter, Her Majesty's Minister of Water Supply for the State of Victoria, shall give the necessary directions herein accordingly.

TOM FORRISTAL  
Clerk of the Executive Council

## PORT FAIRY WATERWORKS TRUST

At the Executive Council Chamber, Melbourne, the  
twenty-seventh day of May, 1980

PRESENT:

His Excellency the Governor of Victoria  
Mr Haddon Storey | Mr Crozier  
Mr Ramsay

## CONSENT TO BORROWING \$40 000

Under the powers conferred by the Water Act and all other powers enabling him in that behalf, His Excellency the Governor of the State of Victoria, by and with the advice of the Executive Council of the said State, hereby consents to the Port Fairy Waterworks Trust borrowing the sum of Forty thousand dollars (\$40 000) to meet the cost of water supply.

And the Honorable Frederick James Granter, Her Majesty's Minister of Water Supply for the State of Victoria, shall give the necessary directions herein accordingly.

TOM FORRISTAL  
Clerk of the Executive Council

## YARRAWONGA URBAN WATERWORKS TRUST

At the Executive Council Chamber, Melbourne, the  
twenty-seventh day of May, 1980

PRESENT:

His Excellency the Governor of Victoria  
Mr Haddon Storey | Mr Crozier  
Mr Ramsay

## CONSENT TO BORROWING \$45 000

Under the powers conferred by the Water Act and all other powers enabling him in that behalf, His Excellency the Governor of the State of Victoria, by and with the advice of the Executive Council of the said State, hereby consents to the Yarrawonga Urban Waterworks Trust borrowing the sum of Forty-five thousand dollars (\$45 000) to meet the cost of water supply works.

And the Honorable Frederick James Granter, Her Majesty's Minister of Water Supply for the State of Victoria, shall give the necessary directions herein accordingly.

TOM FORRISTAL  
Clerk of the Executive Council

## SHIRE OF GISBORNE SEWERAGE AUTHORITY

At the Executive Council Chamber, Melbourne, the  
twenty-seventh day of May, 1980

PRESENT:

His Excellency the Governor of Victoria  
Mr Haddon Storey | Mr Crozier  
Mr Ramsay

## CONSENT TO BORROWING \$250 000

Under the powers conferred by the Sewerage Districts Act and all other powers enabling him in that behalf, His Excellency the Governor of the State of Victoria, by and

with the advice of the Executive Council of the said State, hereby consents to the Shire of Gisborne Sewerage Authority borrowing the sum of Two hundred and fifty thousand dollars (\$250 000) in two separate loans of One hundred and twenty-five thousand dollars (\$125 000) to meet the cost of sewerage works as set forth in the detailed statement bearing date 21 May 1980.

And the Honorable Frederick James Granter, Her Majesty's Minister of Water Supply for the State of Victoria, shall give the necessary directions herein accordingly.

TOM FORRISTAL  
Clerk of the Executive Council

#### HEYFIELD SEWERAGE AUTHORITY

At the Executive Council Chamber, Melbourne, the  
twenty-seventh day of May, 1980

PRESENT:

His Excellency the Governor of Victoria  
Mr Haddon Storey | Mr Crozier  
Mr Ramsay

#### CONSENT TO BORROWING \$50 000

Under the powers conferred by the Sewerage Districts Act and all other powers enabling him in that behalf, His Excellency the Governor of the State of Victoria, by and with the advice of the Executive Council of the said State, hereby consents to the Heyfield Sewerage Authority borrowing the sum of Fifty thousand dollars (\$50 000) to meet the cost of sewerage works as set forth in the detailed statement bearing date 21 May 1980.

And the Honorable Frederick James Granter, Her Majesty's Minister of Water Supply for the State of Victoria, shall give the necessary directions herein accordingly.

TOM FORRISTAL  
Clerk of the Executive Council

#### PORT FAIRY SEWERAGE AUTHORITY

At the Executive Council Chamber, Melbourne, the  
twenty-seventh day of May, 1980

PRESENT:

His Excellency the Governor of Victoria  
Mr Haddon Storey | Mr Crozier  
Mr Ramsay

#### CONSENT TO BORROWING \$45 000

Under the powers conferred by the Sewerage Districts Act and all other powers enabling him in that behalf, His Excellency the Governor of the State of Victoria, by and with the advice of the Executive Council of the said State, hereby consents to the Port Fairy Sewerage Authority borrowing the sum of Forty-five thousand dollars (\$45 000) to meet the cost of sewerage works as set forth in the detailed statement bearing date 21 May 1980.

And the Honorable Frederick James Granter, Her Majesty's Minister of Water Supply for the State of Victoria, shall give the necessary directions herein accordingly.

TOM FORRISTAL  
Clerk of the Executive Council

#### RIDDELLS CREEK SEWERAGE AUTHORITY

At the Executive Council Chamber, Melbourne, the  
twenty-seventh day of May, 1980

PRESENT:

His Excellency the Governor of Victoria  
Mr Haddon Storey | Mr Crozier  
Mr Ramsay

#### CONSENT TO BORROWING \$10 000

Under the powers conferred by the Sewerage Districts Act and all other powers enabling him in that behalf, His Excellency the Governor of the State of Victoria, by and with the advice of the Executive Council of the said State, hereby consents to the Riddells Creek Sewerage Authority, borrowing the sum of Ten thousand dollars (\$10 000) to meet the cost of the sewerage works as set forth in the detailed statement bearing date 21 May 1980.

And the Honorable Frederick James Granter, Her Majesty's Minister of Water Supply for the State of Victoria, shall give the necessary directions herein accordingly.

TOM FORRISTAL  
Clerk of the Executive Council

#### UPPER YARRA SEWERAGE AUTHORITY

At the Executive Council Chamber, Melbourne, the  
twenty-seventh day of May, 1980

PRESENT:

His Excellency the Governor of Victoria  
Mr Haddon Storey | Mr Crozier  
Mr Ramsay

#### APPROVAL OF SITE OF TREATMENT WORKS AND COMPULSORY ACQUISITION OF LAND

Under the powers conferred by the Sewerage Districts Act and all other powers enabling him in that behalf, His Excellency the Governor of the State of Victoria, by and with the advice of the Executive Council of the said State, doth hereby approve of the site for treatment works and the compulsory acquisition of the land required for the treatment works and sewerage purposes by the Upper Yarra Sewerage Authority, being the land shown on the plan approved by the Governor in Council, by and with this Order and deposited in the office of the State Rivers and Water Supply Commission, Melbourne, (Corr. No. 76/1562/71.)

And the Honorable Frederick James Granter, Her Majesty's Minister of Water Supply for the State of Victoria, shall give the necessary directions herein accordingly.

TOM FORRISTAL  
Clerk of the Executive Council

#### PUBLIC SERVICE ACT 1974

At the Executive Council Chamber, Melbourne, the  
twenty-seventh day of May, 1980

PRESENT:

His Excellency the Governor of Victoria  
Mr Haddon Storey | Mr Crozier  
Mr Ramsay

#### AMENDMENT OF SCHEDULE THREE TO PUBLIC SERVICE ACT 1974

In pursuance of the power conferred by section 22 of the Public Service Act 1974, His Excellency the Governor of the State of Victoria in the Commonwealth of Australia, by and with the advice of the Executive Council of the

said State, doth by this Order amend Schedule Three to the Public Service Act 1974 by adding to column one the words "Office of the Transport Regulation Board" and to column two the words "Chairman, Transport Regulation Board".

And the Honorable Rupert James Hamer, Her Majesty's Premier of the State of Victoria, shall give the necessary directions herein accordingly.

TOM FORRISTAL  
Clerk of the Executive Council

## LANDS DEPARTMENT NOTICES

### APPROACHING LAND SALES

Sale of Crown Land, will be held at the under-mentioned places and dates, viz.:-

	No. of Gazette
Goroke, Monday, 2 June 1980	29

### SALE OF FREEHOLD LAND BY AUCTION

Mundoona, Friday, 1 August 1980	38
Swan Hill, Monday, 23 June 1980	29

### SALE OF FREEHOLD LAND BY AUCTION

**MUNDOONA**—A sale of Freehold Land, by auction, for and on behalf of the Minister of Education will be held ON THE SITE on FRIDAY 1 AUGUST 1980 at TEN-THIRTY A.M. To be conducted by M. McALIECE, Land Officer, Seymour.

The land will be offered for sale subject to the following conditions:—

A deposit of at least 10% of the purchase price must be paid at the sale and balance within 60 days. Purchaser to arrange for and bear cost of registration of transfer of title.

Department of Crown Lands and Survey  
Melbourne, 28 May 1980

#### Lot 1.

#### PARISH OF MUNDOONA

Being the former Mundoona Primary School site fronting the east side of a bitumen road about 28 kilometres north of Shepparton (via Bunbartha).

Area 2 acres 2 roods 20 perches (1.06 ha). Allotments 5A and 5B of section C and being the whole of the land more particularly described in Crown Grant Volume 1270 Folio 841 and Crown Grant Volume 1493 Folio 425—(L.7-2348).

### TOOLERN CREEK FRONTAGE RESERVE REGULATIONS

I, William Vasey Houghton, Her Majesty's Minister of Lands in and for the State of Victoria, in pursuance of the powers conferred on me by section 13 of the Crown Land (Reserves) Act 1978, do hereby make the following Regulations for or with respect to the Crown land in the Township of Toolern Vale, Parish of Yangardook (hereinafter referred to as the "Reserve") permanently reserved for Public Purposes by Order in Council dated 12 March 1980 (vide Government Gazette of 19 March 1980), together with the abutting portion of the permanent Public Purposes Reserve along Toolern Creek as is shown by green colour on plan marked "TV/20.3.80" attached to the Department of Crown Lands and Survey correspondence No. Rs.10926.

1. The Reserve shall be open to the public at all times free of charge.

#### 2. No person shall—

- (a) enter or remain in the Reserve who may offend against decency as regards dress, language or conduct, or who may behave in a disorderly, unseemly or offensive manner, or create or take part in any disturbance;
- (b) carry, use or discharge any firearm, air-rifle or any other weapon in the Reserve;
- (c) disturb, interfere with or destroy any animal or bird or its lair or nest in the Reserve;
- (d) interfere with, mark, cut names on or in any way damage or injure any buildings, gates, fences, barriers, seats, signs or any other improvements in the Reserve;
- (e) interfere with, mark, cut names on or in any way damage, injure or disturb any tree, shrub, plant or other vegetation or any sand, stone, gravel, rock or any other earth in the Reserve;
- (f) remove any sand, soil, gravel or rock from the Reserve;
- (g) pick leaves, bark or flowers from any vegetation in the Reserve;
- (h) leave or deposit any glass, bottle, tin, can, waste paper, refuse or any other rubbish in the Reserve except in a receptacle provided for the purpose;
- (i) light or cause to be lit any fire in the Reserve except in any properly constructed fireplace provided for the purpose;
- (j) drive any motorized vehicle off any formed road or parking area provided in the Reserve or in contravention of any authorized sign therein;
- (k) put or allow to remain in the Reserve any sheep, horses, cattle, pigs or other animals except as hereinafter provided.

3. No dog shall be in the Reserve unless such dog is and continues to be at all times controlled by a chain cord or leash, and any dog found wandering at large in the Reserve may be seized and delivered to the proper officer of the Municipality concerned—(Rs.10926).

Given under my hand at Melbourne on 21 May 1980

W. V. HOUGHTON  
Minister of Lands

Every person who contravenes or fails to comply with these Regulations shall be liable to the penalties prescribed in section 13 of the Crown Land (Reserves) Act 1978.

### PROPOSED REVOCATION OF TEMPORARY RESERVATIONS OF LANDS BY ORDERS IN COUNCIL

In pursuance of the provisions of Section 10 of the Crown Land (Reserves) Act 1978, notice is hereby given that it is the intention of the Governor in Council to revoke the temporary reservations of lands by Orders in Council hereunder referred to, viz.:

**SANDHURST (BENDIGO)**—The temporary reservation by Order in Council of 9 August 1906, of 3186 square metres of land in the Parish of Sandhurst, at Bendigo (in section K), as a site for Drainage purposes—(L.6-1661).

**BEECHWORTH**—The temporary reservation by Order in Council of 21 March 1940 of 26.10 hectares of land in the Parish of Beechworth (in section A<sup>1</sup>) as a site for Public Purposes—(B.349<sup>(23)</sup>) (Rs.5024).

**LAKES ENTRANCE**—The temporary reservation by Order in Council of 26 February 1957 of 2149 square metres of land in the Township of Lakes Entrance, Parish of Colqhoun, in section 7, as a site for a Children's Playground—(C.383F<sup>(9)</sup>) (Rs.7551).

**BOROKA (HALL'S GAP)**—The temporary reservation by Order in Council of 9 December 1935 of 20.08 hectares of land in the Parish of Boroka as a site for Public Purposes (Hall's Gap Picnic Reserve), revoked as to part by various Orders, so far only as the portion thereof containing 1155 square metres as shown on Certified Plan No. 104510 lodged in the Central Plan Office, is concerned—(B.678<sup>(6)</sup>) (Rs.477).

**EPPING**—The temporary reservation as a site for Cemetery and the withholding from sale leasing and licensing by Order in Council of 27 November 1876 of 4.046 hectares of land in the Township of Epping, revoked as to part by Order of 18 September 1951, so far only as the portion thereof containing 3034 square metres as shown on Certified Plan No. 104480 lodged in the Central Plan Office, is concerned—(E.57<sup>(a)</sup>) (Rs.6306).

W. V. HOUGHTON  
Minister of Lands

#### LOCAL LAND BOARDS

In pursuance of the provisions of section 34 of the Land Act 1958, notice is hereby given that public hearings at the following place and times will be conducted by a Local Land Board being duly appointed in that behalf.

**OUYEN**—Shire of Walpeup Council Chambers commencing at 9.00 a.m. on Tuesday, 17 June 1980, and continuing on following days as necessary. The Local Land Board will deal with a number of the applications which have been received for Improvement Purchase Leases for allotments as advertised in the *Sunraysia Daily*, *North West Express* and *The Guardian* of 30 April 1980 and the *Pinnaroo Border Times* of 1 May 1980.

W. V. HOUGHTON  
Minister of Lands

Department of Crown Lands and Survey  
Melbourne, 21 May 1980

## TENDERS

#### PUBLIC WORKS DEPARTMENT

Tenders are invited for the purposes indicated hereunder and will be received at 2 Treasury Place, Melbourne, 3002, until **TWO** p.m. on dates shown.

Tenders must be addressed to the Minister of Public Works with the envelope endorsed "Tender for

". Hand-delivered tenders must be placed in the Department's tender box in the foyer, Ground Floor, 2 Treasury Place, Melbourne.

Tenders documents are available from the Contracts Office, Room 29, 2 Treasury Place, Melbourne, and where indicated, at offices of Inspectors of Works.

★Tenders for works identified with star (★) will only be considered from Contractors qualified for repairs and painting works. Any Tenderers wishing to qualify may obtain the application form from the Contracts Office.

**Tuesday, 10 June 1980**

#### Building, Electrical and Mechanical Works

**ANGLESEA**—Supply and delivery of 3 No. Four (4) Module Relocatable Buildings—F.O.G. Port Melbourne, Recreation Development Division. (W.O., Geelong, Ballarat and Bendigo.)

★**BACCHUS MARSH**—Various works (renovations). Northcote Homes.

**CAMBERWELL**—Proposed ground floor alterations, Audio-Visual Education Centre.

**CRESWICK**—Construction of multi-purpose gallery, Primary School. (W.O., Ballarat.)

**WODONGA**—New library and internal alterations, Technical School. (W.O., Wangaratta.)

#### Miscellaneous

**COLLINGWOOD** (Re-advertisement, Amended Specification)—Supply of Electronic Equipment, Technical College.

**HEALESVILLE**—Maintenance cleaning period 16 June 1980 to 30 June 1983, Police Station.

**MELBOURNE**—Maintenance cleaning period 1 July 1980 to 30 July 1983, Public Offices.

**SORRENTO**—Maintenance cleaning period 1 July 1980 to 30 June 1983, Police Station. (W.O., Mornington.)

**VARIOUS**—Annual furniture contract (seating) for the period 1 July 1980 to 30 June 1981, Various.

**VARIOUS**—Supply and deliver library furniture for the period 1 July 1980 to 30 June 1981, Various.

**Wednesday, 18 June 1980**

#### Building, Electrical and Mechanical Works

★**BAYVIEW**—Internal and external repairs and painting, Primary School No. 4752.

★**BENALLA**—External and internal renovations, including mechanical and electrical services, Primary School No. 31. (W.O., Benalla and Wangaratta.)

**CHADSTONE PARK**—Alterations, additions and cyclic maintenance (library and staff admin. conversion), Primary School.

**CHADSTONE PARK**—Mechanical service, alterations, additions and cyclic maintenance (library and staff admin. conversion), Primary School.

**CHATHAM**—Alterations to school (staff improvements, art craft conversion), Primary School.

**CHATHAM**—Mechanical services, alterations, staff improvements, art craft conversion, Primary School.

★**CHILTERN**—General repairs and painting, Primary School No. 327. (W.O., Benalla and Wangaratta.)

**HAMILTON**—New covered way, Serology Laboratory. (W.O., Hamilton and Warrnambool.)

★**INVERLEIGH**—Internal renovations, Police Station and Residence. (W.O., Geelong.)

**KANGAROO FLAT**—Mechanical services, fire reinstatement and staff upgrade, Technical School. (W.O., Bendigo.)

**KANGAROO FLAT**—Electrical services, fire reinstatement and staff upgrade, Technical School. (W.O., Bendigo.)

★**KERANG**—Cyclic maintenance, external repairs and painting, Technical/High School. (W.O., Bendigo and Swan Hill.)

**MANANGATANG**—Services to relocatable buildings (electrical services), Consolidated School. (W.O., Bendigo and Swan Hill.)

**MELBOURNE**—Supply and installation of card and key access system, Police Building.

**MYRTLEFORD**—Staff and administration improvements, art craft conversion, Consolidated School. (W.O., Wangaratta.)

**MYRTLEFORD**—Electrical services, staff and administration improvements, art craft conversion, Consolidated School. (W.O., Wangaratta.)

**PRESTON**—Partition alterations, first floor, Labour and Industry.

★**WOODEND**—(Amended specification.) External and part internal repairs and painting, Primary School.

#### Miscellaneous

**PORT MELBOURNE**—Purchase of three (3) only 50 mm (2") diaphragm pumps, Depot.

**PORT MELBOURNE**—Purchase of six (6) x 50 mm (2") trash pumps and two (2) only 75 mm (3") trash pumps, Depot.

**VARIOUS**—Supply of sheet steel furniture for the period 1 July 1980 to 30 June 1981, Various.

**VARIOUS**—Supply of hand planers and jointers (buzzers), period 1 July 1980 to 30 June 1981, Schools and other Government Buildings.

**VARIOUS**—Supply of shaping machines, period 1 July 1980 to 30 June 1981, Schools and other Government Buildings.

VARIOUS—Supply of woodworking thickening machines, period 1 July 1980 to 30 June 1981, Schools and other Government Buildings.

VARIOUS—Supply of grinding machines, period 1 July 1980 to 30 June 1981, Schools and other Government Buildings.

VARIOUS—Supply of woodworking lathes, period 1 July 1980 to 30 June 1981, Schools and other Government Buildings.

VARIOUS—Supply of hacksaw machines and marking off table, period 1 July 1980 to 30 June 1981, Schools and other Government Buildings.

VARIOUS—Supply of universal turret head milling machines, period 1 July 1980 to 30 June 1981, Schools and other Government Buildings.

VARIOUS—Supply of 13 mm drilling machines, period 1 July 1980 to 30 June 1981, Schools and other Government Buildings.

VARIOUS—Supply of woodworking saw-benches, period 1 July 1980 to 30 June 1981, Schools and other Government Buildings.

VARIOUS—Supply of bandsaw machines and spindle borer, period 1 July 1980 to 30 June 1981, Schools and other Government Buildings.

VARIOUS—Supply of plain horizontal milling machines, period 1 July 1980 to 30 June 1981, Schools and other Government Buildings.

VARIOUS—Supply of 260 mm swing engineers' lathes, period 1 July 1980 to 30 June 1981, Schools and other Government Buildings.

VARIOUS—Supply of universal horizontal milling machines, period 1 July 1980 to 30 June 1981, Schools and other Government Buildings.

VARIOUS—Supply of 255/280 mm swing screw-cutting lathes, period 1 July 1980 to 30 June 1981, Schools and other Government Buildings.

VARIOUS—Supply of 305/330 mm swing screw-cutting lathes, period 1 July 1980 to 30 June 1981, Schools and other Government Buildings.

TOM AUSTIN  
Minister of Public Works

Public Works Department  
Melbourne, 27 May 1980

### PRIVATE ADVERTISEMENTS

*Town and Country Planning Act 1961 (Twelfth Schedule)*

CITY OF BENDIGO PLANNING SCHEME 1962

NOTICE THAT A PLANNING SCHEME HAS BEEN PREPARED  
AND IS AVAILABLE FOR INSPECTION

Amendment No. 33

Notice is hereby given that the City of Bendigo in pursuance of its powers under the *Town and Country Planning Act 1961* has prepared an amending planning scheme for the following area:—

All the land enclosed within the black border of the map comprising Schedule 1, commencing 61.3 metres west of Lazarus Street and being the whole of Crown Allotment 522A, Section A, Parish of Sandhurst at Bendigo to be rezoned from "Residential" to "Reserved Industrial".

A copy of the scheme has been deposited at the offices of the Bendigo City Council, Lyttleton Terrace, Bendigo, 3550, the office of the Town and Country Planning Board, 235 Queen Street, Melbourne, 3000, and the Regional Office of the Town and Country Planning Board, 391 Hargreaves Street, Bendigo, 3550, and will be open for inspection during office hours by any person free of charge.

Any persons affected by the Planing Scheme are required to set forth in writing all objections they may have, addressed to the Town Clerk, Municipal Offices, Lyttleton Terrace, Bendigo, 3550 on or before 28 June 1980 and to state whether they wish to be heard in respect of their objections.

28 May 1980  
7268

C. K. BEAMISH, Town Clerk

#### CITY OF CAULFIELD

BY-LAW No. 165—PROCEEDINGS OF COUNCIL (AMENDMENT)  
BY-LAW, 1980

A By-Law of the City of Caulfield made under the provisions of section 197 and 228 of the *Local Government Act 1958*, and numbered 165 for the purpose of altering By-Law No. 151 of the City of Caulfield (Proceedings of Council By-law).

In pursuance of the powers conferred by the *Local Government Act 1958* and of every other power enabling it in that behalf the Mayor, Councillors and Citizens of the City of Caulfield, does hereby order as follows:

1. This By-law shall be known as the Proceedings of Council (Amendment) By-law 1980.

2. By-Law Number 151 of the City of Caulfield is hereby altered as follows:

- (a) clause 28 is hereby repealed;
- (b) there shall be substituted for clause 28 the following clause:

"28. (a) Questions upon notice shall be:

- (i) in writing;
- (ii) respectful in language;
- (iii) delivered to the Town Clerk not less than six days before the time fixed for the ordinary meeting of the Council at which the question is sought to be asked.

(b) The questioner shall state in writing the reason for placing the question upon notice at the ordinary meeting of the Council. If the Town Clerk deems that reason to be insufficient or inadequate, he may:

- (i) refer the question upon notice to a Standing Committee of the Council;
- (ii) reply in writing to the question immediately, without reference to the Council or to a Standing Committee of the Council.

(c) In redirecting the question to a Standing Committee of the Council, or in replying to the question immediately, the Town Clerk shall advise the questioner of the reason or reasons for such redirection or reply.

(d) Questions of the following nature may be redirected or replied to immediately:

- (i) questions which relate to the workings or charter of a Standing Committee of the Council shall be re-directed to that Standing Committee;
- (ii) questions which call for answers readily available in the files of the Council, and to which no expression of opinion is sought, may be replied to immediately, without direction or redirection."

3. This by-law shall apply to and have operation throughout the whole of the municipal district of the City of Caulfield.

The above By-Law as made and passed by the Council of the City of Caulfield on 22 April 1980, and confirmed on 13 May 1980.

Copies of the By-Law are open for inspection, free of charge, during office hours of the office of the Council, corner Hawthorn and Glen Eira Roads, Caulfield.

7258

G. K. CALDER, City Manager

CITY OF DANDENONG

LOAN No. 98

Notice of Intention to Borrow the Sum of \$150 000 for Permanent Works and Undertakings

Notice is hereby given that the Council of the City of Dandenong proposes to borrow the principal sum of One hundred and fifty thousand dollars secured by a charge over the general rates of the municipality such sum to be raised by the grant of a mortgage in accordance with the provisions of the Local Government Act 1958.

1. The maximum rate of interest that may be paid is 12.6 per cent. per annum.

2. The purposes for which the loan is to be applied are:—

	\$
(1) Police Paddocks — Development of Recreational Facilities—Soccer Area—Part Cost	50 000
(2) W. G. Wright Complex—Stage II.—(Indoor Sports Pavilion)	100 000
	150 000

3. The period of the loan shall be ten years.

4. The moneys borrowed shall be repayable by providing out of the municipal fund 20 half-yearly instalments of approximately \$13 397.97 each, including principal and interest on 10 January and 10 July, during the currency of the loan. The first instalment shall be payable on 10 January 1981.

5. Such moneys shall be repayable at the Commercial Bank of Australia Limited, Head Office, Melbourne, or, at such other places as the lender may direct.

The plans and specifications and the estimate of the cost of the proposed works and a statement showing the proposed expenditure of the moneys to be borrowed are open for inspection at the office of the Council of the City of Dandenong, at 30 Clow Street, Dandenong.

7269

C. G. DICKIE, Town Clerk

hereunder which has been purchased, taken or acquired by it, shall be a Public Highway on and from the date of publication of this Order in the Government Gazette.

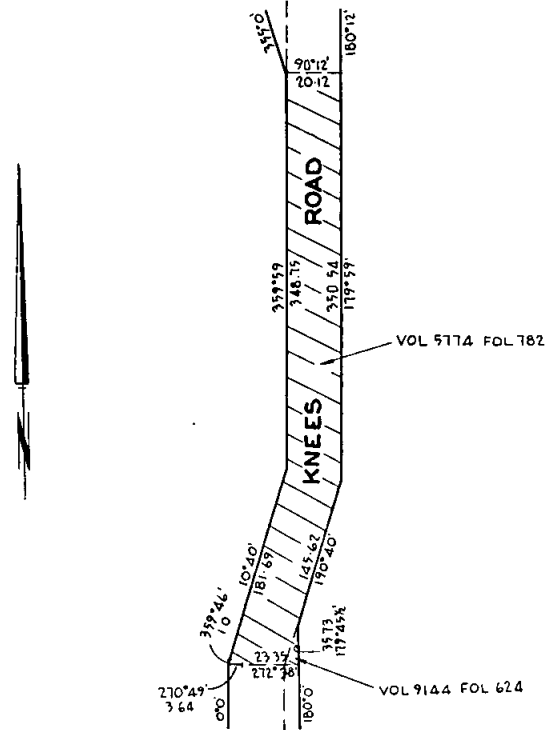

CITY OF DONCASTER AND TEMPLESTOWE

Pursuant to the provisions of section 522 of the Local Government Act 1958, the Council of the City of Doncaster and Templestowe hereby directs that the road being part of Knees Road, Park Orchards, as shown on Certificates of Title Volume 5774, Folio 782, and Volume 9144, Folio 624, shown hatched on the plan annexed

Dated 21 May 1980

The common seal of the Mayor, Councillors and Citizens of the City of Doncaster and Templestowe was hereto affixed, in the presence of—

R. D. WHITE, Councillor  
W. H. LARKIN, Councillor  
G. J. MORTON, Town Clerk

7270

(SEAL)

Town and Country Planning Act 1961

CITY OF HORSHAM PLANNING SCHEME

NOTICE THAT A PLANNING SCHEME HAS BEEN PREPARED AND IS AVAILABLE FOR INSPECTION

Amendment No. 56, 1980

Notice is hereby given that the Council of the City of Horsham, in pursuance of its powers under the Town and Country Planning Act 1961, has prepared a planning scheme to rezone from Residential "A" to Public Purposes "Country Roads Board" that part of the municipal district of the City of Horsham comprising Allotments 46, 48 and 58 on the east side of Kalkee Road, south of Bleakley Street shown enclosed within a black border on the Planning Scheme Map.

A copy of the scheme has been deposited at the Office of the Council of the City of Horsham, Urquhart Street, Horsham, and at the office of the Town and Country Planning Board, 235 Queen Street, Melbourne, and will be open for inspection thereat, during office hours by any person, free of charge.

Any persons affected by the Planning Scheme may be required to set forth in writing, all objections they may have addressed to the Town Clerk, City of Horsham, Post Office, Box 511, Horsham, on or before 28 August 1980 and to state whether they wish to be heard in respect of their objections.

7232

A. R. CONN, Town Clerk

CITY OF MILDURA

LOAN No. 112

ADVANCE BY OVERDRAFT

Notice of Intention to Borrow the Sum of \$60 000 for Permanent Works and Undertakings

1. Notice is hereby given that the Council of the City of Mildura proposes to borrow the principal sum of Sixty thousand dollars secured by a charge over the General Rates of the Municipality, such sum to be raised by overdraft in accordance with the provisions of the Local Government Act 1958.

(i) The rate of interest not to exceed the maximum rate set by the Loan Council for short term borrowing by Local Government, and currently 11.25% per annum.

(ii) The purpose for which the Advance is to be applied is for Part cost purchase of Roadmaking Plant.

(iii) The maximum period of the Advance shall be four years.

(iv) The moneys borrowed shall be repayable by providing out of the Municipal Fund such sum as Council determines and provides for in the Estimates of Expenditure each year during the term of the Advance.

(v) Such moneys shall be repayable at the National Bank Trading Bank Limited, Deakin Avenue, Mildura.

2. (a) Any request that the proposal to obtain the advance be submitted to a poll of voters should be made by not less than five per cent. of the persons whose

names are inscribed on the municipal roll in writing under their hands, delivered to the Minister for Local Government together with the sum of \$100.00. Such request should be in the hands of the Minister on or before 29 June 1980.

(b) The Minister may grant or reject any such request for a poll, and give such directions in respect of the \$100.00, as he considers appropriate.

(c) If the Minister grants a request for a poll, the provisions of sections 401 to 406 of the *Local Government Act 1958* shall apply with such modification as the Minister may direct.

D. B. GOSS, Town Clerk and Chief Executive  
Civic Building, Deakin Avenue, Mildura, 3500 7292

## CITY OF RINGWOOD

## CHANGE OF STREET NAME

Notice is hereby given that the Council of the City of Ringwood did resolve at a meeting of the Council held on 19 May 1980 to rename the following street:

That the street previously known as Berea Avenue be now known as Berea Court.

7233 A. W. HALL, Town Clerk

## CITY OF SANDRINGHAM

## LOAN No. 135

*Notice of Intention to Borrow the Sum of \$50 000 for Permanent Works and Undertakings*

Notice is hereby given that the Council of the City of Sandringham intends to borrow Fifty Thousand Dollars (\$50 000) secured by a charge over the general rates of the Municipality by the grant of a mortgage in accordance with the provisions of the *Local Government Acts*.

In connection therewith the following information is stated—

1. The amount of the principal moneys which it is proposed to borrow is \$50 000.
2. The maximum rate of interest that may be paid is 12 per centum per annum.
3. The period of the loan shall be 15 years.
4. The times at which the moneys borrowed are to be repayable are 2 July and 2 January in each year during the currency of the loan. The first instalment shall be payable on 2 January 1981 and the final instalment on 2 July 1995.
5. The place at which the moneys borrowed are to be repayable is the National Bank Savings Bank, 24 Bay Road, Sandringham, or such other place as the Bank from time to time may require.
6. The purpose for which the loan is to be applied is Municipal Offices Extensions (part cost).
7. The manner in which the loan is to be liquidated is by the provision out of the Municipal Fund in each half year during the currency of the loan of the sum of \$3632.45 which includes principal and interest.

The plans, specifications and estimate of the cost of works and a statement showing the proposed expenditure of the moneys to be borrowed are open for inspection at the Municipal Offices, Royal Avenue, Sandringham.

Dated 20 May 1980

7234 P. S. SHERMAN, Town Clerk

*Town and Country Planning Act 1961 (Twelfth Schedule)*  
CITY OF SHEPPARTON—CITY OF SHEPPARTON  
PLANNING SCHEME 1953

NOTICE THAT A PLANNING SCHEME HAS BEEN PREPARED AND IS AVAILABLE FOR INSPECTION

*Amendment No. 52, 1980*

Notice is hereby given that the Council of the City of Shepparton, in pursuance of its powers under the *Town and Country Planning Act 1961* has prepared a planning scheme for the following area:

Nos. 465, 469 and 471 Wyndham Street, Shepparton.

A copy of the Scheme has been deposited at the office of the Council, Civic Centre, Shepparton, and at the

office of the Town and Country Planning Board, 235 Queen Street, Melbourne, and will be open for inspection during office hours by any person free of charge.

Any persons affected by the Planning Scheme are required to set forth in writing all objections they may have, addressed to the Town Clerk, City of Shepparton, P.O. Box 989, Shepparton, on or before 28 June 1980, and to state whether they wish to be heard in respect of their objections.

7235 I. L. GILBERT, Acting Town Clerk

*Town and Country Planning Act 1961 (Twelfth Schedule)*  
CITY OF SHEPPARTON—CITY OF SHEPPARTON  
PLANNING SCHEME 1953

NOTICE THAT A PLANNING SCHEME HAS BEEN PREPARED AND IS AVAILABLE FOR INSPECTION

*Amendment No. 53, 1980*

Notice is hereby given that the Council of the City of Shepparton, in pursuance of its powers under the *Town Planning Act 1961* has prepared a planning scheme for the following area—the whole of the municipal district of the City of Shepparton.

A copy of the Scheme has been deposited at the office of the Council, Civic Centre, Shepparton, and at the office of the Town and Country Planning Board, 235 Queen Street, Melbourne, and will be open for inspection during office hours by any person free of charge.

Any persons affected by the Planning Scheme are required to set forth in writing all objections they may have, addressed to the Town Clerk, City of Shepparton, P.O. Box 989, Shepparton, on or before 28 June 1980, and to state whether they wish to be heard in respect of their objections.

7236 I. L. GILBERT, Acting Town Clerk

## CITY OF SUNSHINE

## COUNCIL RESERVES' BY-LAW No. 128

Notice is hereby given that the Council of the City of Sunshine has made a By-law known as the Council Reserves' By-law and numbered 128, for the purpose of—

- (i) preserving public decency;
- (ii) suppressing nuisances;
- (iii) controlling and managing and preserving commons and public reserves of which the management is vested in the Council;
- (iv) imposing collecting and receiving charges or entrance fees for clubs, associations or persons using or entering in or upon any land purchased or rented or otherwise provided or granted or given by any person to the Council of the municipality of the City of Sunshine for the providing of pleasure grounds or places of public resort or public recreation and also for the regulation of the conduct of persons using or being upon or in such grounds or places;
- (v) preserving good order and decency in any building belonging to the municipality or under the control and management of the council and preventing damage to such building or to the furniture or fittings thereof and regulating any meeting or gathering held therein;
- (vi) controlling and regulating the use of premises with a view to preventing objectionable noises at unreasonable times;
- (vii) regulating traffic and processions;
- (viii) prohibiting spitting or expectorating on footpaths;
- (ix) regulating the use of public places by street hawkers and itinerant traders dealing in goods;
- (x) controlling the use of footways or roadways by children using skates, trucks, scooters or other like toy vehicles;
- (xi) generally for maintaining the good rule and government of the municipality.

Notice is further given that a copy of the By-law is open for inspection free of charge, during office hours at the Municipal Offices, Alexandra Avenue, Sunshine.

7293 T. W. DEUTSCHMANN, Town Clerk



TOWN OF PORTLAND

LOAN No. 144

Notice of Intention to Borrow the Sum of \$25 890 for Permanent Works and Undertakings

Notice is hereby given that the Council of the Town of Portland proposes to borrow the sum of \$25 890 secured by a charge over the general rates of the Municipality, such funds to be raised by the grant of a mortgage in accordance with the provisions of the *Local Government Act 1958*.

1. The maximum rate of interest that may be paid is 12.6 per cent. per annum.
2. The purpose for which the loan is to be applied is provision of electricity supply to Council's Fitzgerald Street Industrial Estate.
3. The period of the loan shall be ten years.
4. The moneys borrowed shall be repayable by providing out of the Municipal Fund twenty equal half-yearly instalments of \$2312.49 each including principal and interest on 1 July and 1 January during the currency of the loan. The first instalments shall be payable on 1 January 1981.
5. Such moneys shall be payable to the Portland Harbor Trust Commissioners at the Office of the Portland Harbor Trust Commissioners at Portland.

The Plans and specifications and the estimate of the cost of the proposed works and a statement showing the proposed expenditure of the moneys to be borrowed are open for inspection at the Office of the Council of the Town of Portland, Gawler Street, Portland.

Dated 23 May 1980

7259

P. K. SHANAHAN, Town Clerk

TOWN OF PORTLAND

LOAN No. 145

Notice of Intention to Borrow the Sum of \$50 000 for Permanent Works and Undertakings

Notice is hereby given that the Council of the Town of Portland proposes to borrow the principal sum of \$50 000 secured by a charge over the general rates of the municipality, such sum to be raised by the grant of a mortgage in accordance with the provisions of the *Local Government Act 1958*.

1. The maximum rate of interest that may be paid is 12.6 per centum per annum.
2. The purposes for which the loan is to be acquired are:—

Completion of Peter Street main drain	\$ 15 000
Further development—Industrial Estate (Fitzgerald Street)	35 000
	50 000

3. The period of the loan shall be ten years.
4. The monies borrowed shall be repayable by providing out of the municipal fund half yearly 20 instalments of \$3 449.52, each including principal and interest on 24 June and 24 December during the currency of the loan with a balancing payment on 24 June 1990. The first instalment shall be payable on 24 December 1980.

5. Such monies shall be repayable to the Australian Mutual Provident Society, Corner Bourke and William Streets, Melbourne.

The plans and specifications and the estimate of the proposed works and a statement showing the proposed expenditure of the monies to be borrowed are open for inspection at the Office of the Council of the Town of Portland at Gawler Street, Portland.

Dated 27 May 1980

7349

P. K. SHANAHAN, Town Clerk

Town and Country Planning Act 1961 (Twelfth Schedule)

TOWN OF STAWELL PLANNING SCHEME 1963

AMENDMENT No. 19, 1980

Notice that a planning scheme has been prepared and is available for inspection.

Notice is hereby given that the Council of the Town of Stawell, in pursuance of its powers under the *Town and Country Planning Act 1961*, has prepared a planning scheme for the following purposes:—

1. Deletion of "Special Uses" zone No. 1 from the Planning Scheme.
2. Rezoning the following properties from "Special Uses" zone to "Residential" zone:—  
Part Crown Allotment 2, section 30, Parish of Stawell;  
Part Crown Allotment 2, section 31, Parish of Stawell;  
Presbyterian Church Reserves, section 30, Parish of Stawell.
3. Rezoning tennis court situated on Crown Land in the vicinity of Crown Allotments 1, 1A and 3, section 81B, Parish of Stawell, from "Special Use" No. 2 to "Public Open Space—Preservation of Native Flora".
4. Rezoning Crown Allotment 2, section 39A, Parish of Stawell from "Special Use" No. 2 to "Special Use—Defence Department Purpose".
5. To rezone Part Crown Allotment 1 and Crown Allotments 6, 7 and 8, section 66, Parish of Stawell from "Public Open Space—Tennis Courts" to "Residential".

A copy of the Scheme has been deposited at the Town Hall, Main Street, Stawell and the office of the Town and Country Planning Board, 235 Queen Street, Melbourne and will be open for inspection to any person free of charge during office hours.

Any persons affected by the planning scheme are required to set forth in writing to the Town Clerk, Town of Stawell, Town Hall, Stawell, 3380, all objections they may have on or before 28 August 1980 and to state whether they wish to be heard in respect of their objections.

7271

D. H. HUTTON, Town Clerk

BOROUGH OF SEBASTOPOL

LOAN No. 19

Notice of Intention to Borrow the Sum of \$95 000 for Permanent Works and Undertakings

Notice is hereby given that the Council of the Borough of Sebastopol proposes to borrow the principal sum of ninety-five thousand dollars (\$95 000), secured by a charge over the general rates of the municipality, such sum to be raised by the grant of a mortgage in accordance with the provisions of the *Local Government Act 1958*.

1. The maximum amount of interest which may be paid is 12.6% per annum.
2. The purpose for which the loan is to be applied is:—

Construction of Squash Courts (Part Cost).

3. The period of the loan shall be twenty years.
4. The money shall be repayable by providing out of the Municipal Fund forty half-yearly instalments of \$6554.10 including principal and interest on 1 February and 1 August during the currency of the loan. The first instalment shall be repayable on 1 February 1981.

5. Such moneys shall be repayable at the office of the State Savings Bank of Victoria, 233 Collins Street, Melbourne, 3000.

The plans and specifications and estimate of the cost of the proposed works and a statement showing the proposed expenditure of the moneys to be borrowed are open for inspection at the office of the Council, Town Hall, Sebastopol.

7294

P. B. COOK, Town Clerk

## BOROUGH OF WONTHAGGI

LOAN No. 57

## Special Order to Borrow

Notice is hereby given that the following special order was passed by the Council of the Borough of Wonthaggi on 21 April 1980 and confirmed on 19 May 1980:—

That the Borough of Wonthaggi borrows the sum of \$40 000 from the State Savings Bank of Victoria by the grant of a mortgage secured by a charge over the general rates of the municipality and under the following terms:—

1. Amount of the Loan to be \$40 000.
2. Rate of Interest to be paid—11.2 per centum per annum.
3. The loan is to be repaid at the State Savings Bank of Victoria, at the office of the Commissioners, 233 Collins Street, Melbourne.
4. The proceeds of the loan are to be applied for the purpose of Private Street construction pursuant to approved schemes.
5. The loan is to be liquidated by twenty (20) half-yearly instalments of \$3375.00 including principal and interest. The first instalment shall be payable on 1 January 1981.

7261

A. A. N. DEED, Town Clerk

## SHIRE OF ARARAT—PARISH OF TATYOON

## COMPULSORY ACQUISITION OF LAND

Whereas the Council of the Shire of Ararat deems it expedient to exercise its power of taking compulsorily land described in the Schedule hereto for the building of a road and of acquiring certain land for that purpose and whereas the Council has caused to be prepared such maps and other papers setting out the general description of the work or undertaking for which the land proposed to be taken is to be used, the description of the land proposed to be taken, and the names of the owners reputed owners, lessees or reputed lessees and the mortgagees and occupiers of that land so far as these names are known to or can be ascertained by the Council and whereas the said maps and other papers are deposited at the office of the said Council at Ararat and are and shall be open for inspection by all persons interested at all reasonable hours for the space of forty (40) clear days after publication of this notice in the *Victoria Government Gazette*; Now notice is hereby given to all persons affected by the proposed taking of the said land to set forth in writing addressed to the said Council or the Shire Secretary of the Shire of Ararat within forty (40) clear days from the publication of this notice all objections which they may have to the taking of the said land.

## SCHEDULE HEREINBEFORE REFERRED TO

That part of Crown Allotment 172 Parish of Tatyoon bounded as follows:—Commencing 4.14 metres from the south-east corner of Crown Allotment 172 bearing north-west 292 deg. 41 min. for 229.53 metres thence north-west 272 deg. 37 min. for 5.83 metres thence north-east 48 deg. 41 min. for 46.26 metres thence north-west 331 deg. 53 min. 40 sec. for 427.68 metres thence east 88 deg. 33 min. for 38.08 metres thence south-east 152 deg. 37 min. 20 sec. for 321.37 metres thence south-east 143 deg. 54 min. 20 sec. for 146.94 metres thence south-east 130 deg. 21 min. 20 sec. for 141.83 metres to the point of commencement.

Dated 23 May 1980, Shire Hall, Ararat

7297

L. M. CONSTABLE, Shire Secretary

## SHIRE OF BACCHUS MARSH

## NOTICE OF CHANGE IN STREET NAMES

Notice is hereby given that in accordance with the provisions of the *Local Government Act 1958*, the Council of the Shire of Bacchus Marsh at a meeting held on 15 May 1980, resolved that the names of the following streets be changed:

*Old Names*—David Street; Mitchell Street.

*New Names*—David Court; Mitchell Court.

*Location*—Running north off Nelson Street, Township of Darley, Parish of Korkuperrimul in the Shire of Bacchus Marsh.

7229

IAN D. MORRIS, Shire Secretary

## UNITED SHIRE OF BEECHWORTH

LOAN No. 32

## Notice of Intention to Borrow

Notice is hereby given that the Council of the United Shire of Beechworth intends to borrow Twenty Thousand Dollars (\$20 000) secured by a charge over the General Rates of the Municipality by the grant of a Mortgage in accordance with the provisions of the *Local Government Acts*.

In connection therewith the following information is stated:—

- (a) The amount of the principal moneys which it is proposed to borrow is \$20 000.
- (b) The maximum rate of interest that may be paid is 12.2 per centum per annum.
- (c) The times which the moneys borrowed are to be repayable are 1 February 1981, and 1 August and 1 February during the years 1981–1984 inclusive and that the place such moneys shall be repayable is at the Bank of New South Wales, Beechworth.
- (d) The purpose for which the loan is to be applied is:—

Maintenance, repairs and painting of various Council property:—

	\$
Town Hall	6 000
Murmungee Hall	7 500
Memorial Hall	4 000
Various properties	2 500
	20 000

- (e) The manner in which the loan is to be liquidated is by the provision out of the Municipal Fund in each half-year during the currency of the loan of the sum of \$3233.47 which includes principal and interest.

The plans and specifications and estimate of the cost of the works and a statement showing the proposed expenditure of the moneys to be borrowed are open for inspection at the Shire Office.

Dated 22 May 1980

7295

G. T. GRAY, Shire Secretary

## SHIRE OF BENALLA

## CHANGE OF ROAD NAMES

Notice is hereby given that pursuant to the provisions of section 535 of the *Local Government Act 1958*, the Shire of Benalla has by resolution changed the names of the following roads:—

*Description*—Government Road from Witt Street to Yarrowonga Road, Benalla.

*Old Name*—North Benalla-Winton Road (part).

*New Name*—Murrays Road.

*Description*—Government road from N/E corner C.A. 22 Section C, Parish of Benalla West to the boundary of the Parish of Benalla.

*Old Name*—Roe Road.

*New Name*—Four Mile Road.

7348

S. LONDON, Shire Secretary

## SHIRE OF BUNGAREE

LOAN No. 18

## Notice of Intention to Borrow the Sum of \$20 000 for Permanent Works and Undertakings

Notice is hereby given that the Council of the Shire of Bungaree proposes to borrow the principal of \$20 000 secured by a charge over the General Rates of the Municipality such sum to be raised by the grant of a mortgage in accordance with the provisions of the *Local Government Act 1958*.

1. The maximum rate of interest that may be paid is 12.5 per cent per annum.

2. The purpose for which the loan is to be applied is:

Purchase of a new 8 Tonne Tip Truck and the conversion of the store shed to amenities block at the Shire Depot.

3. The period of the loan shall be 5 years.

4. The money borrowed shall be repayable by providing out of the Municipal Fund, ten half yearly instalments of approximately \$2749.64 each including principal and interest on 1 September, and 1 March during the currency of the loan. The first instalment shall be payable on 1 September 1980.

5. Such money shall be payable to the Australia and New Zealand Banking Group Ltd., corner Bridge and Peel Streets, Ballarat.

The specifications and the estimate of the cost of the works and a statement showing the proposed expenditure of the moneys to be borrowed are open for inspection at the office of the Council of the Shire of Bungaree, at Shire Offices, Leigh Creek, Victoria.

7354 B. R. JOHNSON, Shire Secretary

SHIRE OF KORUMBURRA  
PART RESCISSION—ROAD DEVIATION ORDER  
Jeetho Road

Notice is hereby given that the Council of the Shire of Korumburra at its meeting on 21 May 1980 resolved that the following part of Road Deviation Order which appeared in the *Government Gazette* dated 2 April 1980 be rescinded.

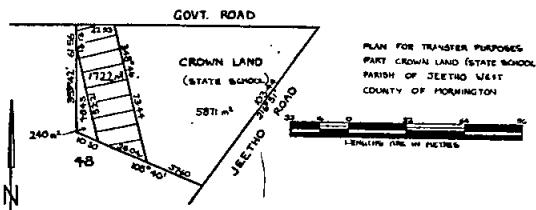

26 May 1980  
7355 W. O. CLARK, Shire Secretary

ORDER OF SHIRE OF MANSFIELD TO DECLARE LAND A PUBLIC HIGHWAY

In pursuance of powers conferred by section 522 of the *Local Government Act 1958* the Council of the Shire of Mansfield doth hereby direct that the land in the Parish of Mansfield shown hatched on the plan annexed hereto which has been purchased taken or acquired by it shall be a public highway from and after the date of publication of this Order in the *Government Gazette*.

Dated 12 May 1980

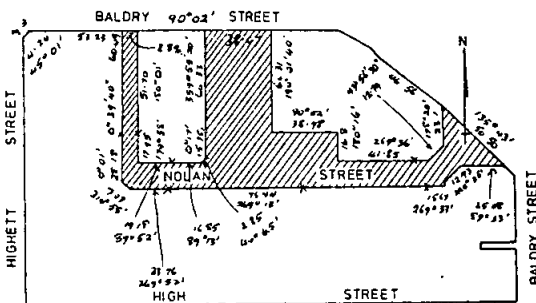

The common seal of the President, Councillors and Ratepayers of the Shire of Mansfield was hereto affixed, in the presence of—

(SEAL) JAMES M. CUMMINS, Councillor  
D. L. QUAYLE, Councillor  
F. WALSHE, Secretary

Mal, Ryan Jackson and Glen, Mansfield 7263

Town and Country Planning Act 1961  
SHIRE OF NARRACAN—YALLOURN NORTH PLANNING SCHEME 1951

NOTICE THAT A PLANNING SCHEME HAS BEEN PREPARED AND IS AVAILABLE FOR INSPECTION  
Amendment No. 5

Notice is hereby given that the Shire of Narracan in pursuance of its powers under the *Town and Country Planning Act 1961* has prepared a planning scheme for the Yallourn North Planning Scheme area, more particularly being part of Lot 16, L.P.54605, C.A.13B, Section C, Parish of Tanjil East.

A copy of the scheme has been deposited at the Shire Office, Princes Highway, Trafalgar, and at the office of the Town and Country Planning Board, 235 Queen Street, Melbourne, and will be open for inspection during office hours by any person free of charge.

Any persons affected by the Planning Scheme are required to set forth in writing all objections they may have, addressed to the Shire Secretary, Shire of Narracan, P.O. Box 140, Trafalgar on or before 28 August 1980, and to state whether they wish to be heard in respect of their objections.

Dated 22 May 1980  
7291 W. F. NELSON, Shire Secretary

Town and Country Planning Act 1961 (Twelfth Schedule)  
SHIRE OF SEYMOUR—SEYMOUR PLANNING SCHEME

NOTICE THAT A PLANNING SCHEME HAS BEEN PREPARED AND IS AVAILABLE FOR INSPECTION  
Amendment No. 50, 1980

Notice is hereby given that the Shire of Seymour in pursuance of its powers under the *Town and Country Planning Act 1961* has prepared an amending Planning Scheme for the purpose of:

Re-zoning Lots 7, 8, 9, 10, 11, 12, 13, 14, 16, 17, 18, 19, 20, 21, 22, 23 on Plan of Subdivision Number 2149 Township and Parish of Seymour from "Residential" to "Public Purpose Reserve".

A copy of the Scheme has been deposited at the Shire Office, Seymour and at the Office of the Town and Country Planning Board, 235 Queen Street, Melbourne and will be open for inspection during office hours by any person free of charge.

Any persons affected by the Planning Scheme are required to set forth in writing all objections they may have, addressed to the Shire Secretary, Shire Office, Seymour on or before 28 August 1980 and to state whether they wish to be heard in respect of their objections.

16 May 1980  
7230 J. W. MATHEWS, Municipal Clerk

Town and Country Planning Act 1961 (Twelfth Schedule)  
SHIRE OF WARANGA PLANNING SCHEME

INTERIM DEVELOPMENT ORDER  
NOTICE THAT A PLANNING SCHEME HAS BEEN PREPARED AND IS AVAILABLE FOR INSPECTION  
Amendment No. 1

Notice is hereby given that the Shire of Waranga in pursuance of its powers under the *Town and Country Planning Act 1961* has prepared a Planning Scheme for the following areas to be rezoned from "Rural D" to "Rural C".

(a) The area between the Rural "C" Zone on the North Western side of the Waranga Basin and the Rushworth-Tatura Road.

(b) The area between the Rural "C" zone on the Western side of the Waranga Basin and the Rushworth-Tatura Road.

(c) The area between the Rural "C" Zone on the Southern side of the Waranga Basin and the Goornong-Murchison Road.

The amendment will remove anomalies in the Order that prevent the practical subdivision of contiguous land in the existing "Rural C" and "Rural D" Zones in the areas referred to above.

A copy of the Scheme has been deposited at the Offices of the Shire of Waranga, High Street, Rushworth and at the office of the Town and Country Planning Board, 235 Queen Street, Melbourne and will be open for inspection during office hours by any person free of charge.

Any persons affected by the Planning Scheme are required to set forth in writing all objections they may have addressed to the Shire Secretary, Shire of Waranga, Shire Offices, High Street, Rushworth, on or before 28 June 1980, and to state whether they wish to be heard in respect of their objections.

7231

G. A. SHIELL, Shire Secretary

SHIRE OF WARRNAMBOOL  
NAMING OF ROAD

Notice is hereby given that, at the meeting on 14 May 1980, Council did name a road running east west between Russell's Road and Sim's Road, Mailors Flat, and north of Allotments 22A, M, E, B, G and F, Parish of Meerai—Primmer's Road.

7272

By order of the Council  
ALAN J. BOWES, Shire Secretary

Town and Country Planning Act 1961 (Twelfth Schedule)  
SHIRE OF YACKANDANDAH PLANNING SCHEME 1965

## TOWNSHIP OF YACKANDANDAH

NOTICE THAT A PLANNING SCHEME HAS BEEN PREPARED  
AND IS OPEN FOR INSPECTION

## Amendment No. 8

Notice is hereby given that the Council of the Shire of Yackandandah in pursuance of its powers under the Town and Country Planning Act 1961, has prepared a Planning Scheme for:—

All land fronting High Street between Wellsford Street and William Street to a depth of 50.3 metres from the High Street frontage.

A copy of the Scheme has been deposited at the Office of the Shire of Yackandandah, High Street, Yackandandah, at the Regional Office of the Town and Country Planning Board, Jack Hore Place, Wodonga and at the office of the Town and Country Planning Board, 235 Queen Street, Melbourne and will be open for inspection during office hours by any person, free of charge.

Any persons affected by the Planning Scheme are required to set forth in writing all objections they may have, addressed to the Shire Secretary, Shire of Yackandandah, High Street, Yackandandah, on or before 28 June 1980 and to state whether they wish to be heard in respect of their objections.

Dated 21 May 1980

7260

D. J. GRIFFITHS, Shire Secretary

## GEELONG WATERWORKS AND SEWERAGE TRUST

Pursuant to Section 60 of the *Geelong Waterworks and Sewerage Act 1958* (No. 6263) the Trust has prepared plans to indicate the particulars of sewers and underground works, the construction of which the Trust intends to begin at a date not less than one month after publication of the notices, in or adjacent to the following localities within the Drainage Area.

Saltworks Rising Main/Gravity Main Portarlington Road, Newcomb—Shire of Bellarine.

Boundary Road and East Geelong Technical School, East Geelong—City of Geelong.

Notice is hereby given that the plans indicated are open for public inspection at the Trust's Offices, 61-67 Ryrie Street, Geelong between the hours of 9.00 a.m. and 5.00 p.m. from Monday to Friday (public holidays excepted) by the owners or occupiers of land or premises within the Drainage Area.

7273

L. C. SPITTY, Acting Secretary

## MOE WATERWORKS TRUST

## EIGHTH SCHEDULE

Notice to the owners in the undermentioned streets and private land courts and alleys opening thereto.

Della Torre Road (Lots 1, 2, 3, 4, 33, 32, 31, 30, 29, 28, and 27).

Tabuteau Road (All).

Saxtons Drive (Lots 17 to 26 inclusive).

Bubb Street (Lots 11 to 16 inclusive).

Being sub-division known as Stage 3 Moe Estates Pty. Ltd.

The main pipe in the said streets being laid down the owners of all tenements situated as above are hereby required on or before 1 July 1980 next to cause a proper pipe and stopcock to be laid so as to supply water within such tenements from the main pipe.

A. DEWAR, Secretary of the Moe Waterworks Trust

7357

## FRANKSTON SEWERAGE AUTHORITY

That the Frankston Sewerage Authority having made provision for carrying off sewage from each and every property, which or any part of which is within the sewerage area hereinafter described, doth hereby declare that on and after 1 June 1980, each and every property, which or any part of which is within the said sewerage area, shall be deemed to be a seweraged property within the meaning of the *Sewerage Districts Act 1958*.

The boundaries of the sewerage area hereinbefore referred to are:—

## Area No. 210

Comprising the following properties in Marathon Drive, Mount Eliza—

Lot 1 L.P.90595; Lot 2 L.P.75566; Lots 2 to 5 inclusive L.P.23983 and Lot 19 L.P.23983.

By order of the said Authority

7262

K. E. MAIR, Chairman  
A. H. BUTLER, Secretary

## LILYDALE SEWERAGE AUTHORITY

## CONSTRUCTION OF SEWERS—LILYDALE

The Lilydale Sewerage Authority gives notice that it intends to construct sewers in the areas detailed below.

A plan showing details of the proposed works may be inspected by any persons during office hours 8.30 a.m. to 6.15 p.m. Thursday and 8.30 a.m. to 5.30 p.m. all other weekdays at the Authority office, 7-9 John Street, Lilydale.

The proposed alignments of the sewers are as follows:

## Contract No. 394

Construction of sewers and manhole to service Lots 191 and 192 Circle Ridge, Chirnside Park.

Consisting of approximately 58 metres of 150-mm diameter sewers and one manhole, commencing from an existing manhole at the rear of Lot 268 Circle Ridge thence in a north-west direction.

7296

W. L. HALSE, Secretary

## LILYDALE SEWERAGE AUTHORITY

## CONSTRUCTION OF SEWERS—LILYDALE

The Lilydale Sewerage Authority gives notice that it intends to construct sewers in the area detailed below.

A plan showing details of the proposed works may be inspected by any persons during office hours 8.30 a.m. to 6.15 p.m. Thursday and 8.30 a.m. to 5.00 p.m. all other weekdays at the Authority office, 7-9 John Street, Lilydale.

The proposed alignment of the sewer is as follows:—

From the existing sewer at the south-east corner of Lot 2, CA.5 Section 17 Maroondah Highway, Coldstream north across the rear of Lot 2 to the south-east corner of Lot 1, CA.5 Section 17.

7358

W. L. HALSE, Secretary

## MOE SEWERAGE AUTHORITY

## GENERAL NOTICE

The above mentioned Sewerage Authority having made provision for carrying off the sewage from each and every property which or any part of which is within the Sewerage Area hereinafter described doth hereby declare that on and after 1 July 1980 each and every property which or any part of which is within the said sewerage area shall be deemed to be seweraged property within the meaning of the Sewerage Districts Act 1958.

The sewerage area hereinbefore referred to shall be known as sewerage area No. 102.

The boundaries of the said Sewerage Area No. 102 are delineated on the plan, which may be inspected at the office of the Moe Sewerage Authority.

By order of the said Sewerage Authority

J. S. DWYER, Chairman  
A. DEWAR, Secretary

7356

## SUNBURY SEWERAGE AUTHORITY

## GENERAL NOTICE

## Sewerage Area No. 7

The above-mentioned Sewerage Authority having made provision for carrying off the sewage from each and every property which or any part of which is within the sewerage area hereinafter described doth hereby declare that on and after 1 June 1980 each and every property which or any part of which is within the said Sewerage Area shall be deemed to be a seweraged property within the meaning of the Sewerage Districts Act 1958.

The general boundaries of the sewerage area herein before referred to are Riddell Road to the north, Horne Street to the east, Cornish Street to the south and Ligar Street to the west.

By Order of the Sunbury Sewerage Authority

J. J. McMAHON, Chairman  
J. M. KELLY, Secretary

7237

Notice is hereby given that an application in the following form, signed by The Most Reverend Ronald Austin Mulkearns and sealed with the seal of The Roman Catholic Trusts Corporation of the Diocese of Ballarat, has been lodged at the office of the Minister of Crown Lands and Survey—

## VICTORIA

## ACT No. 391—FIRST SCHEDULE

I, The Most Reverend Ronald Austin Mulkearns of 340 Wendouree Parade, Ballarat, head or authorized representative of the denomination known as The Roman Catholic Church for the Diocese of Ballarat with the consent of the Corporation styled The Roman Catholic Trusts Corporation for the Diocese of Ballarat of 9 Lyons Street South, Ballarat, trustee of the land described in the subjoined statement of trusts, hereby apply to the Governor of the State of Victoria for leave to dispose of the said land by the means and for the purposes mentioned in the said statement of trusts, and I hereby certify that the said land was permanently reserved from sale by the Governor in Council as a site for Roman Catholic Church purposes. That the only trustee of the said land resident in the State of Victoria is the said corporation styled The Roman Catholic Trusts Corporation for the Diocese of Ballarat and there are no persons entitled to minister in or occupy the same and there are no buildings upon the said land.

Dated 4 August 1978.

RONALD A. MULKEARNS

We consent to this application:

The seal of The Roman Catholic Trusts Corporation for the Diocese of Ballarat was hereunto affixed by its order, in the presence of—

(SEAL) RONALD A. MULKEARNS, Bishop  
A. McINERNEY, Member of the Corporation  
L. FISCALINI, Corporation Trustee

## STATEMENT OF TRUSTS

*Description of Land*—8096 square metres, Township of Shelford, Parish of Doroc, County of Grenville, being Crown Allotment 1, section 11. Commencing at the north-eastern angle of Crown Allotment 1A, section 11; bounded thence by that allotment bearing 270 deg. 00 min. 99.38 metres, by Tolson Street bearing 0 deg. 00 min. 81.47 metres, by Mercer Street bearing 90 deg. 00 min. 99.38 metres and thence by Thomson Street bearing 180 deg. 00 min. 81.47 metres to the point of commencement.

*Names of Trustees*—The Roman Catholic Trusts Corporation of 9 Lyons Street South, Ballarat.

*Powers of Disposition*—Such powers of disposition including powers of sale, lease or mortgage as are contained in *The Roman Catholic Trusts Act 1907*.

*Purposes to which Proceeds of Dispositions are to be Applied*—To such Roman Catholic Church purposes as shall be approved by the Trustee or a majority thereof.

BYRNE, JONES & TORNEY, solicitors of Ballarat for the applicant  
7274

## APPLICATION FOR DISPOSAL OF LAND PURSUANT TO AN ACT TO PROVIDE FOR THE ABOLITION OF STATE AID TO RELIGION

1. The Right Reverend Maxwell McNee Thomas of Wangaratta in the State of Victoria, Bishop of the Church of England Diocese of Wangaratta head or authorised representative of the Denomination known as The Church of England in the Diocese of Wangaratta in Victoria with the consent of The Church of England Trusts Corporation for the Diocese of Wangaratta of Wangaratta aforesaid which is entitled to be registered as the Trustee of the land described in the sub-joined Statement of Trusts hereby applies to the Governor of the State of Victoria for leave to dispose of the said land by means and for the purposes mentioned in the said Statement of Trusts and I hereby certify that the said land was promised or reserved as a site for the Church of England purposes on 25 January 1870.

2. That the Church of England Trusts Corporation for the Diocese of Wangaratta is entitled to be registered as the only Trustee of the said land.

3. There are no buildings erected upon the said land.

4. The only person entitled to minister or occupy same is the Incumbent for the Parish of Seymour namely the Venerable Alan Geoffrey Sapsford of The Rectory, 5 Guild Street, Seymour.

Dated 24 January 1980

Signed, sealed and delivered by the said The Right Reverend Maxwell McNee Thomas, in Victoria, in the presence of—W. H. GLEN.

M. M. THOMAS

The common seal of The Church of England Trusts Corporation for the Diocese of Wangaratta was hereunto affixed, by authority of the Trustees—

(SEAL) D. L. THAWLEY, Trustee  
FRANK W. RICKARD, Trustee  
M. NELSON, Trustee

## STATEMENT OF TRUST

*Description of the Land*—6070 square metres, Parish of Mangalore, County of Anglesey being Crown Allotment 26F. Commencing at the south-western angle of Crown Allotment 26A; bounded thence by that Allotment bearing 90 deg. 00 min. 100.58 metres; by Crown Allotment 26A bearing 180 deg. 00 min. 60.35 metres; by a line bearing 270 deg. 00 min. 100.58 metres; and thence by a road bearing 0 deg. 00 min. 60.35 metres to the point of commencement.

*Name of Trustee*—The Church of England Trusts Corporation for the Diocese of Wangaratta of Wangaratta aforesaid.

*Power of Disposition*—Power to sell lease Mortgage or exchange all or any part of such land subject to the approval of the Bishop of Wangaratta for the time being or during the absence of the Bishop from the Diocese or the vacancy of the See to the approval of the person for

the time being administering the affairs thereof. The land until otherwise disposed of to be held for the purpose for which it was granted or reserved by the Crown.

*Purposes to which Proceeds of Disposition are to be Applied*—To such purposes of the Church of England as may be agreed upon by:

- (1) The Bishop or during his absence from his See or during the vacancy thereof by the person or persons for the time being administering the affairs of the Diocese.
- (2) The Trustees of the Church of England Trusts Corporation for the Diocese of Wangaratta.
- (3) The Minister entitled to occupy the aforesaid land.

MESSRS MAL. RYAN, JACKSON & GLEN, of 9 High Street, Mansfield, solicitors for the applicant 7264

Notice is hereby given that the Life Ministry Centre has applied for a lease pursuant to section 134 of the Land Act 1958 for a term of 21 years in respect of Allotment 6 section 86 Township of Wonthaggi containing 13.7 hectares as a site for Amusement and Recreation. 6443

Notice is hereby given that the partnership heretofore subsisting between James Taylor Murrell, Robert William Hodgson and Roderick McDonald carrying on business as fishing business at the Foreshore Portland under the style or firm of Halcyon Holdings has been dissolved as from 7 February 1980 so far as concerns the said Roderick McDonald who retires from the said firm.

Dated 20 May 1980

7252

RODERICK McDONALD

Notice is hereby given that the Medical Partnership between Dr A. J. Meathrel, Dr J. S. Mincher and Dr M. K. Radnor will be terminated on 30 June 1980. As from 1 July 1980 Dr A. J. Meathrel and Dr M. K. Radnor will continue in Partnership as the Terang Clinic, practising at the same address—156 High Street, Terang, 3264.

7253

A. J. MEATHREL  
J. S. MINCHER  
M. K. RADNOR

#### NOTICE OF DISSOLUTION OF PARTNERSHIP

Notice is hereby given that the partnership heretofore subsisting between Leslie Maldon Keane, Douglas Frank Gore and James Leslie Blair Keane all of Terang Chemists carrying on business as pharmaceutical chemists at 86 High Street Terang under the style or firm name of "Terang Pharmacy" has been dissolved as from 1 July 1980 as far as concerns the said Leslie Maldon Keane who retires from the said firm.

7359

L. M. KEANE  
D. F. GORE  
J. L. B. KEANE

#### Companies Act 1961, Section 272

##### NOTICE OF FINAL MEETING OF MEMBERS

A.I.X. PTY. LTD.  
BUCHAN LAIRD & BUCHAN (SYDNEY) PTY. LTD.  
EMBALMING SERVICES PTY. LTD.  
F. J. CLEMENTS TOOLING PTY. LTD.  
GOPEWLY PRINTING PTY. LTD.  
R.B.P. PTY. LTD.  
RESINITE FLOORING PTY. LTD.  
WADDLE PTY. LTD.  
FIRST A.H.M. PRINTERS PTY. LTD.  
THIRD A.H.M. PRINTERS PTY. LTD.  
FIFTH A.H.M. PRINTERS PTY. LTD.  
SEVENTH A.H.M. PRINTERS PTY. LTD.  
NINTH A.H.M. PRINTERS PTY. LTD.  
HALCOMB TRADING PTY. LTD.  
W. E. POWLEY & CO. PTY. LTD.  
MERTON STATIONERS PTY. LTD.  
NALGOC HOLDINGS PTY. LTD.  
BRONTO BURGERS PTY. LTD.  
TRADITIONAL MOTORS PTY. LTD.  
MYOORA FLATS PTY. LTD.  
EDDAFISS PTY. LTD.  
RESINITE APPLIED PRODUCTS DISTRIBUTION CO. PTY. LTD.  
C. YOUNG INVESTMENTS PTY. LTD.

U.D. FABRICS PTY. LTD.  
PARAPRESS PTY. LTD.  
SASSELLA HOLDINGS PTY. LTD.  
THEROC (N.S.W.) PTY. LTD.  
RAMLER MANUFACTURING CO. PTY. LTD.  
U.R. BRAND PRODUCTS PTY. LTD.  
J.N.K.D. INVESTMENTS PTY. LTD.  
EMBERN HOLDINGS PTY. LTD.  
PINNON CONSTRUCTIONS PTY. LTD.  
UMEN CARLTON PTY. LTD.  
SEDEMIT BEAUTY PTY. LTD.  
CENTRAL MOTORS ENGINEERS PTY. LTD.  
KLEIN BROS. PTY. LTD.  
MILTON HOME BUILDERS PTY. LTD.  
CHARLANE PTY. LTD.  
TADLINK (TRADING) PTY. LTD.  
ALPOC INVESTMENTS PTY. LTD.  
CEMAN HOLDINGS PTY. LTD.  
F. J. CLEMENTS PLASTICS PTY. LTD.  
FISTULOSA PTY. LTD.  
LEEWARRA DEVELOPMENT PTY. LTD.  
RESINITE APPLIED PRODUCTS PTY. LTD.  
ROWLEY & YOUNG INVESTMENTS PTY. LTD.  
WELIES PTY. LTD.  
SECOND A.H.M. PRINTERS PTY. LTD.  
FOURTH A.H.M. PRINTERS PTY. LTD.  
SIXTH A.H.M. PRINTERS PTY. LTD.  
EIGHTH A.H.M. PRINTERS PTY. LTD.  
TENTH A.H.M. PRINTERS PTY. LTD.  
MURROOKE PTY. LTD.  
BUCHAN LAIRD & BUCHAN (CONSULTING ENGINEERS) PTY. LTD.  
CANADIAN INVESTMENTS PTY. LTD.  
NALGOC (VIC.) PTY. LTD.  
NALGOC (AUST.) PTY. LTD.  
ARTFLEX FABRICS (AUST.) PTY. LTD.  
P. YOUNG INVESTMENT CO. PTY. LTD.  
ROSS STRAW PTY. LTD.  
CENTURY PUBLIC RELATIONS PTY. LTD.  
BRISTOL INVESTMENT CO. PTY. LTD.  
LANGLEY & SCOTT PTY. LTD.  
THEROC (SALES) PTY. LTD.  
COLLELUORI PTY. LTD.  
MAISON CONSTRUCTIONS PTY. LTD.  
TALLAH PTY. LTD.  
Y & C SUPPLIERS PTY. LTD.  
VICTORIAN NOMINEES PTY. LTD.  
BROWN HARLEY & ASSOCIATES PTY. LTD.  
TEPKO NOMINEES PTY. LTD.  
PADAMI JEWELLERS PTY. LTD.  
SETROND PTY. LTD.  
LANTEX MANUFACTURING PTY. LTD.  
SUPERMARKET DEVELOPMENT PTY. LTD.  
C & Z (HOLDINGS) PTY. LTD.  
HERCULES DISTRIBUTORS PTY. LTD.

(EACH OF THE ABOVE COMPANIES IN VOLUNTARY LIQUIDATION)

Notice is hereby given that the Final General Meeting of each of the above Companies will be held at Suite G, 8th floor, 406 Lonsdale Street, Melbourne from 2.00 p.m. on 30 June 1980 for the purposes set out in the above section.

Dated 20 May 1980

JOHN A. NEWTON, Liquidator, Suite G, 8th floor, 406 Lonsdale Street, Melbourne 7238

In the matter of the Companies Act 1961; and in the matter of WILLERN HOLDINGS PTY. LTD. (in Voluntary Liquidation)

Notice is hereby given that at an extraordinary general meeting of members of the abovementioned Company duly convened and held at 8 Gillards Street, Mt. Eliza on 19 May 1980 the Special Resolution in the words set out below was duly passed:—

"That in accordance with the provisions of section 254 of the Companies Act 1961, the Company be wound up voluntarily and that the division and transfer by a liquidator of the whole or any part of the assets of the Company upon liquidation to or among members *in specie* or kind be and is hereby sanctioned."

And at the meeting Walter Karl Scharley of W. K. Scharley & Associates of 24 Main Street, Lilydale was appointed liquidator.

Dated 20 May 1980

7240

A. H. WILLINGTON

## Unclaimed Moneys Act 1962

## Register of Unclaimed Moneys held by the—

Name of Owner on Books and Last Known Address	Total Amount Due to Owner	Description of Unclaimed Money	Date when Amount first became Payable
§			
THE ESTATE OF THE LATE GEORGE ADAMS			
Arnold, K., (address unknown)	168.50	Dividend	1.7.76
Jones, D. O., (address unknown)	12.55	"	2.7.76
Dixon, E., (address unknown)	13.60	"	6.7.76
Suchodolski, S., (address unknown)	14.30	"	9.7.76
McIntyre, (Mrs.), (address unknown)	12.55	"	12.7.76
Martin, K. G., (address unknown)	16.50	"	12.7.76
Veal, P. B., (address unknown)	24.10	"	
Daws, K., (address unknown)	17.40	"	
Brecht, P. (Mrs.), (address unknown)	17.40	"	
Iasenza, Giovanni, (address unknown)	35.69	"	19.7.76
Hayden, K., (address unknown)	23.70	"	15.7.76
Halliwell, B. M., (address unknown)	22.85	"	
Chambers, N. A., (address unknown)	14.20	"	19.7.76
Psaila, Joe, (address unknown)	35.69	"	
Isenza, Giovanni, (address unknown)	35.69	"	21.7.76
Caddaye, J. A., (address unknown)	35.69	"	
Name and address unknown	11.80	"	
Gallagher, A. E., (address unknown)	13.42	"	22.7.76
Kline, R. W., (address unknown)	24.05	"	
Cotter, David M., (address unknown)	45.60	"	
Kovacevic, Mario, (address unknown)	12.55	"	23.7.76
Schieder, H. A. and A. M., (address unknown)	17.00	"	
Adams, Jack, (address unknown)	25.35	"	26.7.76
Svalbe, Gunar, (address unknown)	13.42	"	28.7.76
Chapple, A. and Liddle, R., (address unknown)	11.42	"	
Bendeyast, T., (address unknown)	22.67	"	
Coatman, L. E., (address unknown)	30.00	"	
Hassan, I., (address unknown)	19.50	"	
Paulse, S., (address unknown)	24.05	"	29.7.76
Hamilton, A., (address unknown)	39.10	"	3.8.76
Hutchinson, D., (address unknown)	12.60	"	
Hulett, A. L., (address unknown)	26.50	"	
Norchester, P., (address unknown)	17.10	"	
Crane, L., (address unknown)	17.65	"	
Layfield, Gail M., (address unknown)	12.70	"	5.8.76
Young, N. B., (address unknown)	12.70	"	6.8.79
O'Conner, G. A. P. C., (address unknown)	13.45	"	9.8.79
Farral, E. L. (Miss), (address unknown)	24.05	"	
Smith, C. I., (address unknown)	16.85	"	11.8.76
Williams, L., (address unknown)	14.30	"	
Lee, G. R., (address unknown)	10.15	"	12.8.76
Hill, M., (address unknown)	17.10	"	
Stoihenovski, D., (address unknown)	14.15	"	16.8.76
Watts, Wendy, (address unknown)	24.55	"	17.8.76
Di Santo, V., (address unknown)	21.50	"	
Egan, Ken, (address unknown)	24.55	"	
Hammond, J. J., (address unknown)	14.75	"	18.8.76
King, R., (address unknown)	10.05	"	23.8.76
Carbery, Pamela F. (Mrs.), (address unknown)	38.50	"	20.8.76
Doucon, Terry Tim, (address unknown)	143.70	"	5.4.77
Duxbury, F., (address unknown)	46.80	"	
Cassar, S., (address unknown)	44.00	"	
Ferro, Maria, (address unknown)	11.25	"	24.8.76
Van Der Berg, M. J., (address unknown)	23.70	"	25.8.76
Hays, Frank, (address unknown)	16.35	"	26.8.76
Williams, K. J., (address unknown)	13.45	"	
Ballard, P. J. and Neil, D. A., (address unknown)	16.35	"	
Bezzina, Monica, (address unknown)	10.75	"	
Urzia, Joe, (address unknown)	22.05	"	
Kelly, Vicky and Bocquet, Tony, (address unknown)	27.92	"	27.8.76
Szabo, Miklos, (address unknown)	14.50	"	
Scott, S., (address unknown)	34.00	"	30.8.76
Hanna, J., (address unknown)	10.60	"	
Prosser, K. and J., (address unknown)	24.55	"	31.8.76
Peters, Sussie, (address unknown)	14.85	"	
O'Connor, Rita, (address unknown)	23.70	"	2.9.76
Campbell, E. M. (Mrs.), (address unknown)	11.40	"	8.9.76
Manini, E., (address unknown)	11.40	"	9.9.76
Mathieson, M. and J., (address unknown)	11.40	"	
Spencer, A., (address unknown)	12.50	"	13.9.76
Borr, P., (address unknown)	23.70	"	
Branislav, R., (address unknown)	38.80	"	14.9.76
Seddon, E. S., (address unknown)	12.55	"	15.9.76
Ayecua, Loanna, (address unknown)	11.40	"	16.9.76
Scarlatto, G., (address unknown)	19.00	"	
Compston, Merle, (address unknown)	11.50	"	17.9.76

## Unclaimed Moneys Act 1962

## Register of Unclaimed Moneys held by the—

Name of Owner on Books and Last Known Address	Total Amount Due to Owner	Description of Unclaimed Money	Date when Amount first became Payable
S			
THE ESTATE OF THE LATE GEORGE ADAMS—continued			
Jones, J. J., (address unknown)	11.35	Dividend	20.9.76
Wright, J., (address unknown)	11.60	"	21.9.76
Golden, J., (address unknown)	13.42	"	23.9.76
Jones, J. L. J., (address unknown)	11.50	"	27.9.76
Frank, K., (address unknown)	11.27	"	"
Dobbin, D., (address unknown)	10.70	"	29.9.76
Brits, S., (address unknown)	11.50	"	30.9.76
Alderson, E., (address unknown)	23.25	"	"
Barrett, B. and M., (address unknown)	16.35	"	1.10.76
Coad, R. (Mr. and Mrs.), (address unknown)	23.70	"	"
Giacomini, (Mr. and Mrs.), (address unknown)	10.70	"	4.10.76
"The Two Diggers", c/o Dario Giacomini, (address unknown)	10.70	"	"
Olsen, J. and A., (address unknown)	15.15	"	8.10.76
Bilowski, Rob, (address unknown)	15.15	"	"
Prothero, J. and Morris, W., (address unknown)	19.50	"	11.10.76
Calabro, A., (address unknown)	29.05	"	12.10.76
Servis, F. W., (address unknown)	13.07	"	13.10.76
"Gay Lad", c/o D. Griffiths (Mrs.), (address unknown)	24.10	"	14.10.76
"Retirement Fund", c/o D. Norman, (address unknown)	24.10	"	"
"Gagaid", c/o Alan Gilbert, (address unknown)	10.70	"	18.10.76
"Shafay", c/o F. Rogers, (address unknown)	33.65	"	"
Cas, Mirella, (address unknown)	11.40	"	21.10.76
Swannell, J., (address unknown)	24.10	"	"
Tetty, M. B. A., (address unknown)	11.25	"	22.10.76
Lucas, A. and B., (address unknown)	13.45	"	"
Kelly, Gillian, (address unknown)	10.70	"	"
Roberts, P. J., (address unknown)	19.25	"	"
Sotiropoulos, M., (address unknown)	19.25	"	"
Lane, L., (address unknown)	19.25	"	"
Scheiner, Betsy P., (address unknown)	19.25	"	25.10.76
Walker, B., (address unknown)	11.30	"	"
Lowry, M. J., (address unknown)	16.00	"	26.10.76
McDonald, R. and Lestor, A., (address unknown)	11.30	"	28.10.76
"November", c/o Helen Carroll, (address unknown)	11.30	"	"
McLean, H., (address unknown)	19.25	"	"
"Like You", c/o Jimmy Ranov, (address unknown)	11.40	"	"
"Travel", c/o James Ranov, (address unknown)	10.45	"	"
"Margal Syn.", c/o Alan A. Richards, (address unknown)	10.70	"	29.10.76
"Permagang", c/o A. R. Arnold, (address unknown)	10.70	"	"
Tayrovic, Ana, (address unknown)	19.55	"	"
Coppey, G. M., (address unknown)	29.05	"	"
Hili, M., (address unknown)	24.02	"	1.11.76
Alchin, M. T. and Salvi, P., (address unknown)	24.10	"	4.11.76
Fenyk, M., (address unknown)	24.95	"	"
Machalkova, Jana, (address unknown)	10.45	"	5.11.76
Catlin, J., (address unknown)	10.05	"	8.11.76
Polites, G. S., (address unknown)	19.50	"	10.11.76
McKenna, A., (address unknown)	23.60	"	11.11.76
Hyatt, L., (address unknown)	19.25	"	"
Woodman, C., (address unknown)	23.80	"	"
Turnbull, G. and M., (address unknown)	19.25	"	"
Justice, P. and I., (address unknown)	11.30	"	"
Reeve, O. (Mrs.), (address unknown)	10.32	"	"
Stone, R. I., (address unknown)	19.55	"	"
Thompson, R., (address unknown)	21.90	"	"
Dolereit, L. and A., (address unknown)	10.75	"	"
McLaughlan, Thomas and Lois, (address unknown)	24.50	"	"
Pearce, B., (address unknown)	10.05	"	12.11.76
Joore, M. C., (address unknown)	18.35	"	22.11.76
Walsh, A. and M., Wilson, D. and Draper, R., (address unknown)	36.30	"	24.11.76
Santa, (address unknown)	10.00	"	25.11.76
Gregor, R. J. E., (address unknown)	13.80	"	29.11.76
Jones, F. M. (Mrs.), (address unknown)	129.90	"	"
Cross, J. E., (address unknown)	10.50	"	2.12.76
Robertson, Eddy, (address unknown)	29.12	"	8.12.76
Meagher, J. W., (address unknown)	58.42	"	"
Mulchey, B., (address unknown)	22.40	"	"
Keys, D. (Mrs.), (address unknown)	12.10	"	10.12.76
Name and address unknown	13.10	"	"
Thotolus, K. and Mario A., (address unknown)	24.55	"	23.12.76
Sutton, A. N., (address unknown)	20.00	"	5.1.77
Clayton, Colac, (address unknown)	12.10	"	21.1.77
Kerstan, H. R., (address unknown)	75.55	"	14.2.77
Allendire, E., (address unknown)	11.15	"	15.2.77
Ferguson, Gary, (address unknown)	19.50	"	"
Yates, Les, (address unknown)	12.75	"	24.2.77



## Unclaimed Moneys Act 1962

Register of Unclaimed Moneys held by the—

Name of Owner on Books and Last Known Address	Total Amount Due to Owner	Description of Unclaimed Money	Date when Amount first became Payable
\$			
THE ESTATE OF THE LATE GEORGE ADAMS—continued			
Wilson, H., (address unknown)	11.90	Dividend	7.3.77
Broadstock, D., (address unknown)	20.55	"	22.3.77
Arghittu, G., (address unknown)	17.70	"	"
Angen, E., (address unknown)	22.95	"	"
Shields, C. E., (address unknown)	11.60	"	27.4.77
Baldwin, P., c/o P.O. Box 630, Mildura	13.02	"	2.5.77
Raven, C. (Mrs.), (address unknown)	24.05	"	10.5.77
Sharp, D. B., (address unknown)	49.50	"	14.5.77
Pemberton, Bob, (address unknown)	22.70	"	1.6.77
Deakin, K. J. and L. D. (address unknown)	26.60	"	8.7.77
Lomas, K., (address unknown)	33.25	"	20.7.77
Bellhouse, V. (Mrs), (address unknown)	199.50	"	15.8.77
Main, D. P. (Mr and Mrs), (address unknown)	24.20	"	3.8.77
Herc, A. (address unknown)	531.30	"	29.8.77
Beechag, (Mr and Mrs), W. S., J. Kibbs St, Turner A.C.T.	19.50	"	17.8.77
Wilson, C. (Mrs), (address unknown)	10.00	"	26.8.77
Railton, H. N. (address unknown)	21.00	"	"
Butt, R. (address unknown)	11.80	"	30.8.77
Harkins, Hugh (address unknown)	11.50	"	2.9.77
Love, Paul J. (address unknown)	447.25	"	"
Orbach, P., Box 166, Collingwood	86.80	"	9.9.77
Orbach, P., (address unknown)	14.05	"	"
The Commercial Bank Aust. (address unknown)	12.35	"	23.9.77
De Vries, C., (Mr and Mrs), (address unknown)	162.00	"	1.10.77
Stevens, J. L., (address unknown)	19.55	"	18.10.77
Kelly, P., (address unknown)	11.10	"	21.10.77
Steehan, D. R., 61 Murphy St, South Yarra	66.70	"	28.10.77
Thymis, T., and Contis., N., (address unknown)	10.70	"	9.11.77
Lang, M., (address unknown)	41.60	"	14.11.77
Kudelka, W. R. and S. R. (address unknown)	219.45	"	15.11.77
Burdett, D. (Mrs), 776 Plenty Rd, South Morang	13.85	"	11.11.79
Hastie, E., Ekerman H., 45 Voltri St, Mentone	10.50	"	14.11.79
Salodek, M., 40 Danil St, Albert Park	11.60	"	18.11.77
Garment, S., 264 Swanston St, Melbourne	10.60	"	22.11.77
Poloni, R., 124 Bladin St, North Laverton	11.50	"	"
Feg, I., (address unknown)	10.00	"	21.11.77
M/- Baron Trenk (address unknown)	173.25	"	6.12.77
Gray, L., (Mrs), (address unknown)	96.10	"	23.11.77
Anderson, K., 81 City Rd, South Melbourne	14.37	"	"
Lester, G., (address unknown)	27.30	"	25.11.77
Wilson, R., (address unknown)	312.15	"	30.11.77
Spanob, G., (address unknown)	25.30	"	14.12.77
Gray, L., (Mrs), (address unknown)	15.60	"	19.12.77
Gray, D., 7 Beaufort Crt, Ashburton	15.60	"	"
Phelan, P., (address unknown)	332.00	"	20.12.77
Byrne, A., (address unknown)	10.00	"	30.12.77
Ryan, F. B. and T. H., (Mrs), P.O., Stanhope	18.42	"	24.1.78
Stevenson, B., (address unknown)	13.87	"	"
O'Donnell, R. J., (address unknown)	10.00	"	31.1.78
Bosworth, J. T., (address unknown)	18.60	"	3.2.78
Steele, K., (address unknown)	18.42	"	15.2.78
O'Connell, A., (Mrs), (address unknown)	24.75	"	27.2.78
Wilkins, A. E., (Mrs), (address unknown)	49.50	"	"
Phuangpaka, Thassanee, 691 Burke Rd, Camberwell	38.97	"	2.3.78
Manley, I., 16 Harvey St, Prahran	13.60	"	1.3.78
Kisorssy, G., (address unknown)	82.60	"	6.3.78
Knezevic, S. and R., 4 Maynooth Dr.	10.00	"	10.3.78
Mathews, I., McCarthy, W., (address unknown)	55.30	"	21.3.78
Leclare Syn., 462 Albert St, West Brunswick	20.70	"	6.4.78
Tornabene, S., (address unknown)	10.60	"	4.5.78
Burbury, S. V., (Mrs), (address unknown)	71.67	"	31.5.78
Cahillane, S. and L., 4/800 Warrigal Rd, Chadstone	25.75	"	8.6.78
Dawson-Grove, T., (address unknown)	55.30	"	15.6.78
Pashos, A. and E., (address unknown)	54.40	"	22.6.78
Carroll, W., (address unknown)	206.07	"	30.6.78
Winter-Cooke, W. L., (address unknown)	10.00	"	19.6.78
Ozdemir, A., (address unknown)	20.05	"	30.6.78
Milne, J., (address unknown)	11.20	"	"
Beard, K., (address unknown)	14.80	"	29.6.78
Simeoni, P., (Mrs), (address unknown)	22.05	"	28.6.78
Hendrikse, G. C. and D. L., (address unknown)	21.95	"	"
Lloyd, Ken., (address unknown)	11.20	"	"
Murray, M., (Miss), and Mouser, T., (address unknown)	26.80	"	"
Warry, R. A., 4 The Crescent, Maffra	10.42	"	27.6.78
Norman, G. W., Bearii Via Strathmerton	10.42	"	"
Chauvin, C., (address unknown)	10.70	"	"

## Unclaimed Moneys Act 1962

Register of Unclaimed Moneys held by the—

<i>Name of Owner on Books and Last Known Address</i>	<i>Total Amount Due to Owner</i>	<i>Description of Unclaimed Money</i>	<i>Date when Amount first became Payable</i>
<b>S</b>			
<b>THE ESTATE OF THE LATE GEORGE ADAMS—continued</b>			
Hand, S., (address unknown)	17.80	Dividend	27.6.7
Jenkinson, W., (address unknown)	21.95	"	"
Gibson, G., Flat 5, 17 Queen St, Mornington	21.95	"	"
Negrello, L., (address unknown)	11.20	"	"
Cassar, N. and Simmons, G., (address unknown)	11.20	"	"
Cottman, T., 237 Beveridge St, Swan Hill	11.80	"	"
Cottman, T. (address unknown)	23.90	"	"
Cottman, T. and M., (address unknown)	28.90	"	"
Sacristah, J. and Lopez, I. J., (address unknown)	25.27	"	"
MacDonald, D. W., (address unknown)	49.20	"	23.6.78
Burrows, R. and C., (address unknown)	14.80	"	"
Martiniello, Isidoro, (address unknown)	10.70	"	26.6.78
Young, P. D. E., (address unknown)	10.70	"	"
Powell, Iris and Bob, Job, (address unknown)	21.95	"	"
Cottman, T. and M., 39 Pye St, Swan Hill	33.55	"	"
James, G. S., (address unknown)	11.20	"	"
Mead, G., (address unknown)	11.20	"	"
Gash, N., (address unknown)	12.45	"	"
Paynter, G. M., (address unknown)	18.10	"	22.6.78
Holmes, J. P. J., (address unknown)	13.00	"	23.6.78
Doyle, P. (Mrs.), (address unknown)	35.75	"	"
Stephins, S. M., (address unknown)	34.60	"	"
Rankin, S., (address unknown)	21.95	"	"
Barisic, T., (address unknown)	25.75	"	21.6.78
Henderson, C., (address unknown)	25.75	"	"
Richards, J. C., (address unknown)	22.90	"	"
Byrne, D. W., (address unknown)	33.55	"	"
Sutton, J. W., (address unknown)	24.75	"	22.6.78
Ryan, T. (Mrs.), (address unknown)	18.10	"	20.6.78
Probert, T. and Alderton, T., c/o 194 10th St, Mildura	11.80	"	"
Olerhead, A. D., (address unknown)	10.70	"	21.6.78
Atkinson, T. (Mrs.), (address unknown)	18.10	"	"
Milosevic, T. and Capoviola, N., (address unknown)	18.10	"	"
Haikalis, G. and S., (address unknown)	18.10	"	"
Gowing, J. E., (address unknown)	10.70	"	10.6.78
Jaksa, M., 15-444 Haughton Rd, Clayton	33.55	"	19.6.78
Flynn, M., (address unknown)	13.10	"	"
Parker, O. L., (address unknown)	13.10	"	"
Hayward, J. E., (address unknown)	18.10	"	"
Meier, K. D., (address unknown)	18.10	"	"
McFarlane, A., 82 Regent St, Preston	20.02	"	15.6.78
Bailey, Peter J., 157 Hobart Rd, Launceston, Tas.	25.75	"	"
Hsu, S., (address unknown)	25.75	"	16.6.78
Wait, J. and L., (address unknown)	12.45	"	"
Johnson, A., (address unknown)	12.45	"	"
Moloney, M., 47A Sunbeam Ave, East Ringwood	13.10	"	"
Hatzigrigoriou, C., (address unknown)	10.70	"	"
Micallef, J. and Arena, F., (address unknown)	13.00	"	15.6.78
Bruitzman, C. (Miss) and Cameron, J., 63 Moonee Blvd, Glenroy	11.57	"	"
Robinson, L. (Mr. and Mrs.), 73 Bailey Rd, Mt Evelyn	27.60	"	"
Ryan, W. J., 13 Essex St, Ballarat South	14.20	"	"
Kirchner, R. J., 19 Raglan St, Avondale Heights	25.75	"	"
Pink, D. and N., 36 Kars St, Maryborough	27.95	"	"
Piggins, R., (address unknown)	18.00	"	12.6.78
Taylor, R., (address unknown)	20.20	"	"
Turnbull, S. C. and C., (address unknown)	27.60	"	13.6.78
Hunter, P. and A., 4/38 Pine Ave, Elwood	20.02	"	"
Tratt, M., (address unknown)	13.10	"	"
Watson, N. and Dickins S. E., 236 Bourke St, Melbourne	19.05	"	9.6.78
Dunt, K., 22 Malop St, Geelong	27.25	"	"
Mackenzie, J., (address unknown)	27.60	"	12.6.78
Paskalaki, D., (address unknown)	18.10	"	"
Pickard, B. and Dowling K., (address unknown)	13.10	"	"
Pearce, G., and Paton, (Mrs), (address unknown)	13.10	"	7.6.78
Ash, F. (Mrs), (address unknown)	13.35	"	8.6.78
Bailey, G., (address unknown)	13.10	"	"
Phillips, (Mrs), (address unknown)	10.00	"	"
Wale, K. M. (Mrs), 141 Albion St, Brunswick	16.95	"	"
Deverell, Mick John, (address unknown)	26.80	"	9.6.78
Thompson, M., c/o Kulaba Hughes Creek Rd, Seymour	20.55	"	7.6.78
Sweeney, R. and Flanagan, D., (address unknown)	11.50	"	"
Seidel, P. and Kaboun, M., (address unknown)	13.55	"	"
Giuis, H. P., (address unknown)	13.90	"	1.6.78
Keller, A. and K., (address unknown)	13.55	"	2.6.78
Bruce, A. J., (Mr and Mrs), (address unknown)	13.55	"	"
Burges, S. R., (address unknown)	13.55	"	"

## Unclaimed Moneys Act 1962

Register of Unclaimed Moneys held by the—

Name of Owner on Books and Last Known Address	Total Amount Due to Owner	Description of Unclaimed Money	Date when Amount first became Payable
S			
THE ESTATE OF THE LATE GEORGE ADAMS—continued			
Adams, B., (address unknown)	26.05	Dividend	1.6.78
Apostolou, E., (address unknown)	16.60	"	"
Cotterill, M. L., (address unknown)	16.60	"	"
c/o Lee, K., (Mrs), (address unknown)	27.45	"	"
c/o Williamson, H. M., (address unknown)	13.55	"	30.5.78
Main, M., (Mrs), (address unknown)	13.55	"	"
Austen, D. J., 37 Solomon Cres, Latham, A.C.T.	25.12	"	31.5.78
House, J. and Arbutnott, R., (address unknown)	33.95	"	"
Granter, J., 60 Murphy St, Wodonga	10.47	"	"
Crosbie, L., (Miss), (address unknown)	13.55	"	"
Barnes, T. C., (address unknown)	13.00	"	26.5.78
Tuckerman, O., (address unknown)	27.45	"	"
Chamberlain, D., (address unknown)	10.45	"	"
Weissenfeld, C., (address unknown)	24.20	"	29.5.78
Tome, I., (address unknown)	10.00	"	24.5.78
Nicholls, S., (address unknown)	26.05	"	25.5.78
O'Bryan, Alex 371 Trickett St, Deniliquin, N.S.W.	13.00	"	"
Pearce, N. W., (address unknown)	12.45	"	"
Smedley, J. (Miss) (address unknown)	12.45	"	"
Kozlowski, R., (address unknown)	13.00	"	"
Driscoll, J., (address unknown)	26.05	"	17.5.78
Ashbury, N., (address unknown)	26.05	"	"
Scott, Tanya, (Mrs), (address unknown)	10.50	"	"
Jackson, H., Fitzsumons Lane, Templestowe	26.05	"	"
McPherson, L. and M. and Weissgerber, M., (address unknown)	16.95	"	15.5.78
Allender, P., Lot 14 Patons Rd, Avonsleigh	16.77	"	"
Perna, F., 190 Oxley Flats	25.12	"	"
Joseph, B., (address unknown)	13.00	"	"
McCreary, G. D., (address unknown)	13.00	"	16.5.78
Goss, R. G. and P. J., (address unknown)	16.60	"	"
Scott, Tanya, (Mrs), 43 Cuthberts Rd.	11.65	"	17.5.78
Csanalosi, Joe, (address unknown)	10.60	"	9.5.78
Csanalosi, Joe, (address unknown)	10.25	"	"
Bennett, E., R.M.S., Rochester	25.42	"	"
Barnard, S., 3/64 Davidson St, Traralgon	27.35	"	"
Sutcliffe, J. A., (address unknown)	33.95	"	4.5.78
Amoroso, A., (address unknown)	16.60	"	8.5.78
Medcalf, J., and Hudson, W. and E., (address unknown)	26.60	"	"
Skinner, Gary and Elisabeth, (address unknown)	16.60	"	9.5.78
Ryan, S. (Miss), (address unknown)	27.50	"	1.5.78
McLaunchlan, S., 11 Wood St, Mooroopna	21.50	"	2.5.78
Healey, R., (address unknown)	12.90	"	"
Pattence, I. (Miss), (address unknown)	13.35	"	"
St. John, I., (address unknown)	12.45	"	3.5.78
Beattie, W. K., (address unknown)	26.80	"	"
Huggins, P., (address unknown)	12.45	"	"
Dicker, N. G., (address unknown)	12.45	"	26.4.78
Carmady, T., 2 Fordham Crt, Richmond	10.42	"	"
Job, R. (address unknown)	12.45	"	27.4.78
Haisman, Russell S., (address unknown)	10.50	"	"
Tomie, D., (address unknown)	12.45	"	24.4.78
Curvow, R. (Mr. and Mrs.), (address unknown)	12.45	"	"
Puccini, P., P.O. Box 41, Ashgrove, Qld.	31.62	"	"
Roe, B., (address unknown)	19.05	"	"
Findlay, Ian, 3 Kitson St, Frankston	16.48	"	25.4.78
Phillips, V., 513 Lydiard St North, Ballarat	12.45	"	26.4.78
Bianchini, C., 55 Padbury St, Downer, A.C.T.	11.65	"	20.4.78
Szape, Czko W., (address unknown)	12.45	"	"
Watson, P. (Miss), Guthrie, E. and Anson, C., (address unknown)	31.50	"	21.4.78
Gray, R., (address unknown)	24.75	"	"
Bockwell, G. and Edwards, D., (address unknown)	30.85	"	19.4.78
Bennett, E. J., (address unknown)	19.05	"	"
Davey, N. and Allender, K., 6/18 Pine Ave, Elwood	10.07	"	"
Phillips, J. (Mr. and Mrs.), (address unknown)	14.05	"	20.4.78
Allemand, G., (address unknown)	14.05	"	"
Richardson, Barry, (address unknown)	14.05	"	"
Wells, W., (address unknown)	10.50	"	"
Joyce, T. and B., (address unknown)	38.10	"	17.4.78
Harwood, Anne, (address unknown)	19.05	"	"
Rigby, S. (Mrs.), (address unknown)	26.50	"	18.4.78
Wisewould, P., (address unknown)	26.50	"	"
Sarantakos, G. C., (address unknown)	11.65	"	13.4.78
Hughes, R. W., (address unknown)	18.90	"	14.4.78
Connor, M. L., (address unknown)	19.05	"	"
Toohy, J., (address unknown)	10.50	"	10.4.78
Greenbank, L. R., (address unknown)	10.50	"	11.4.78

## Unclaimed Moneys Act 1962

## Register of Unclaimed Moneys held by the—

Name of Owner on Books and Last Known Address	Total Amount Due to Owner	Description of Unclaimed Money	Date when Amount first became Payable
\$			
THE ESTATE OF THE LATE GEORGE ADAMS—continued			
Storti, R. J., (address unknown)	11.65	Dividend	12.4.78
Craig, H. and J., (address unknown)	18.90	"	"
Jackson, H., (address unknown)	29.80	"	"
Smith, M. (Mrs.), (address unknown)	10.50	"	"
Gallo, G., (address unknown)	14.05	"	13.4.78
Emerson, G. and S., (address unknown)	10.50	"	7.4.78
Doubleday, J. and K., (address unknown)	11.65	"	"
Erscourt, M. C., (address unknown)	11.35	"	"
Howzat, B. B., (address unknown)	10.30	"	"
Kletecka, M., (address unknown)	23.15	"	"
Kent, M., (address unknown)	18.90	"	10.4.78
Baillie, M. and Henry, J., (address unknown)	10.25	"	"
Turner, R., (address unknown)	32.50	"	"
Mehes Jnr., Steven, (address unknown)	10.50	"	6.4.78
Forsyth, M. G. W., (address unknown)	32.60	"	"
Jermyn, C., (Mrs.), Farrwath, N. and Barry, P., (address unknown)	10.50	"	"
Slaats, G. and J., (address unknown)	10.50	"	"
Tsioutsias, George, (address unknown)	13.35	"	"
Mathieson, G., (address unknown)	14.20	"	"
Nilsson, V., (address unknown)	11.55	"	"
Barker, B., (address unknown)	32.60	"	"
Full, S. J. and Saunders, L. L., 3 Waverley St, Norlane	33.45	"	5.4.78
Edwards, J. P. and S. M., (address unknown)	11.65	"	6.4.78
Hughs, B., (address unknown)	10.50	"	"
Koopmans, J., (address unknown)	32.60	"	"
Placogiannakis, E., (address unknown)	10.50	"	"
Driscoll, B., (address unknown)	13.35	"	31.3.78
Dunhoff, E., (address unknown)	12.35	"	4.4.78
Haggart, R., P.O. Box 93, Yallourn	29.15	"	"
Erskine, N., (address unknown)	14.05	"	5.4.78
Crooke, T. and Bell, E. (Mrs), (address unknown)	14.20	"	"
Chisholm, M., (address unknown)	11.10	"	"
Brown, G. H., (address unknown)	14.05	"	28.3.78
Boardman, W. R., (address unknown)	27.35	"	24.4.78
Boardman, W. R., (address unknown)	27.90	"	"
Lister, M., (address unknown)	32.60	"	30.3.78
Maloy, M., (address unknown)	20.55	"	"
Riorvan, R., (address unknown)	31.30	"	22.3.78
Sephton, O. J., (Mrs.), (address unknown)	31.30	"	"
Gleeson, J., (address unknown)	14.05	"	23.3.78
Davyltzis, M., (address unknown)	13.35	"	"
Rayson, L., Bobbin, P. and Mustey, E., (address unknown)	32.60	"	"
Taylor, A., (address unknown)	32.60	"	28.3.78
Kennedy, O., (Mrs.), and Markovski, P., (address unknown)	14.20	"	24.3.78
Mahon, V. A., (address unknown)	14.05	"	21.3.78
Jones, B., (Mrs), (address unknown)	22.20	"	14.3.78
Ivezic, V., Ticket, S., Hotel Bosna and Britain, 253 Williams St, Perth, W.A.	10.30	"	15.3.78
Campbell, I. R., (address unknown)	19.80	"	"
Lang, D., (address unknown)	26.50	"	"
Wines, K., (address unknown)	20.00	"	"
Crouch, P. J. and Letcher, B., 314 and 316 Larter St, Ballarat	11.52	"	"
Thurgood, L. A., Arthur Seat Rd, Red Hill	10.30	"	16.3.78
Arnold, M. and Guest, G., (address unknown)	20.75	"	17.3.78
Black, Geoff, "Brae Park", Branxholme	15.12	"	9.3.78
Kretlow, J. L., (address unknown)	10.00	"	10.3.78
Kuncic, S., 2 Sheakspire Cres, Fraser	24.75	"	"
Ford, J., (address unknown)	24.75	"	"
De Rosa, D., 31 Olive Ave, Mildura	26.50	"	"
Mageean, Jim, (address unknown)	26.50	"	"
Sinclair, H. and B., 61 Weeroona St, Kangaroo Flat	11.37	"	14.3.78
Campbell, A. and M., (address unknown)	15.10	"	"
Prince, S., (Miss) and Cecil, L., (Miss), (address unknown)	14.20	"	6.3.78
Young, D. and Barker, P., (address unknown)	22.20	"	7.3.78
Go Jo Andelbo, 7 Neale St, Preston	13.35	"	"
Olshina, A., (address unknown)	13.35	"	"
Malcolm, G., (address unknown)	14.20	"	8.3.78
Gardner, G. and Carson, E., (address unknown)	13.35	"	2.3.78
Bakers, M. A., c/o P.O. Stawell West, Stawell	11.32	"	"
Tsakalis, Chris, (address unknown)	20.70	"	3.3.78
McDonald, J., (address unknown)	10.00	"	"
Ayford, R., Ripple Brook, Via Drouin	15.12	"	"
Buckland, L., Oasis Caravan Park, Mooroopna	22.37	"	"
Golder, M. M. and Woods, M. M., (address unknown)	26.50	"	6.3.78
Stoddart, R., (address unknown)	24.75	"	"
Johnson, M., (Mrs.), (address unknown)	20.55	"	27.2.78
Cafe, I., (address unknown)	13.35	"	"

## Unclaimed Moneys Act 1962

## Register of Unclaimed Moneys held by the—

Name of Owner on Books and Last Known Address	Total Amount Due to Owner	Description of Unclaimed Money	Date when Amount first became Payable
S			
THE ESTATE OF THE LATE GEORGE ADAMS—continued			
McKoy, K., (Mr. and Mrs.), (address unknown)	20.55	Dividend	1.3.78
Cameron, D., (address unknown)	11.00	"	"
Loeding, E. and K., (address unknown)	11.70	"	23.2.78
Bryson, R. W., M/- Cox (address unknown)	24.75	"	"
Penna, W. and Q., (address unknown)	24.75	"	24.2.78
Gosden, A. J., (address unknown)	13.35	"	"
Marcom, (Mrs.), (address unknown)	24.75	"	27.2.78
Rohlf, M., (address unknown)	31.25	"	17.2.78
N.V.E. Employees (address unknown)	29.05	"	"
Norrie, M/s, c/o Orange Grove Caravan Park, Irymple	30.17	"	"
Hatcher, R. and L. (address unknown)	10.30	"	"
Dicorleto, T., 42 Donald St, Morwell	22.37	"	22.2.78
Non. Vin. Pat., c/o Healesville Post Office, Healesville	22.37	"	"
Anderson, M., (address unknown)	27.35	"	"
Featherstone, F. M. (Mrs), (address unknown)	25.00	"	17.2.78
Yole, J. F., (address unknown)	22.55	"	"
Bird, J., (address unknown)	10.30	"	10.2.78
Reddaway, Geoffrey, (address unknown)	33.95	"	14.2.78
Noble, L. (Miss) and Bartholemew, C. (Miss), (address unknown)	10.30	"	2.2.78
Duxbury, K., (address unknown)	19.80	"	3.2.78
Schatzer, G., 3/22 Crookston Rd, Reservoir	13.42	"	"
Huebner, D., (address unknown)	10.30	"	6.2.78
Hanson, P. R., (address unknown)	10.30	"	"
James, L. (Mrs.), (address unknown)	11.10	"	7.2.78
Bird, J., (address unknown)	15.40	"	10.2.78
Cooney, B. (Mrs.), (address unknown)	19.80	"	31.1.78
Rowell, W., (address unknown)	19.80	"	1.2.78
Stento, Aquilino, 5 Cowra St, North Brighton	11.50	"	"
Wood, D. W., 5/400 Barkly St, Elwood	10.95	"	"
Lewis, G., (address unknown)	10.60	"	"
Bevis, G. S., (address unknown)	10.30	"	20.1.70
Kennedy, G. (Mrs.), 320 Dawson St South, Ballarat	19.50	"	23.1.79
Canty, D. G., (address unknown)	10.30	"	23.1.78
Sturzaker, M., (address unknown)	19.50	"	24.1.78
Laboski, M., 27 Burkier Ave, Kingsbury	10.30	"	"
Rickard, J., c/o G.P.O., Melbourne	27.77	"	"
Ellis, T. J., (address unknown)	10.30	"	"
Roccasalvo, S., 29 Barry St, Brunswick	10.22	"	25.1.78
Russell, Brian, Upper Thomson via Warburton	25.30	"	10.1.78
Buchanan, A., (address unknown)	11.00	"	13.1.78
Morrison, J., (address unknown)	18.60	"	"
Murphy, J. and Lobosco, R., 21 Bastleigh Dve, Glen Waverley	27.35	"	16.1.78
Gooch, L., (address unknown)	10.27	"	"
McKenzie, S. and Connelly, M., (address unknown)	10.30	"	18.1.78
Cigognini, A., (address unknown)	10.70	"	3.1.78
Davies, G., 63 Waren Rd, Mordialloc	11.80	"	4.1.78
Kilpatrick, R., (address unknown)	11.00	"	"
Blay, E. M. (Mrs.), (address unknown)	10.10	"	5.1.78
Mellado, O., 42 Hosken St, Springvale	11.15	"	16.12.77
Rayner, M., (address unknown)	11.00	"	19.12.77
Robinson, K., (address unknown)	11.00	"	20.12.77
Kremmer, Claire, (address unknown)	11.00	"	22.12.77
Kidd, A. C., P.O. Box 58, Terang	15.60	"	"
Rogan, A., 36 Larch Cres, Mt Waverley	23.90	"	14.12.77
Burgess, K., (address unknown)	23.90	"	"
Burgess, K. and Johnston, A., (address unknown)	23.90	"	"
Bug, M., (address unknown)	23.90	"	"
Daly, L., (address unknown)	23.90	"	"
Beard, R. and Cocks, B., (address unknown)	11.00	"	15.12.77
Anderson, M., (address unknown)	23.90	"	16.12.77
Schultes, G., (address unknown)	15.60	"	"
Walker, F., (address unknown)	19.10	"	"
Clarke, C. (Mrs.), (address unknown)	11.00	"	9.12.77
Gallen, M. L. (Miss) and C. M. (Mrs.), (address unknown)	19.10	"	"
Charity, G. H., (address unknown)	10.00	"	12.12.77
McDonough, J. H., H.M.A.S. Cerberus, Westernport	17.62	"	"
Gentle, A., (address unknown)	13.87	"	"
Morgan, R. and Wiseman, N., (address unknown)	11.80	"	13.12.77
Allan, A., (address unknown)	15.60	"	"
Fraser Easton, C. and M. E., 47 George St, Somerset	13.87	"	8.12.77
Name and address unknown	11.80	"	"
De Graat, A. Romeyn, (address unknown)	19.10	"	9.12.77
Crisp, R., (address unknown)	11.80	"	5.12.77
Ryland, M., 83 Wilson St, Horsham	27.77	"	"
Jerrard, R., 34 Maryland Dr, Wendouree	13.50	"	7.12.77
Parsell, H., 33 Griffiths Rd, Upwey	17.10	"	"

## Unclaimed Moneys Act 1962

Register of Unclaimed Moneys held by the—

Name of Owner on Books and Last Known Address	Total Amount Due to Owner	Description of Unclaimed Money	Date when Amount first became Payable
§			
THE ESTATE OF THE LATE GEORGE ADAMS—continued			
Blumiuk, M. C., 32 Talona Cres, Corio	13.32	Dividend	8.12.77
Ross, P., "Gemini Synd", Cnr Arden Crt and Arden St, North Melbourne	45.60	"	1.12.77
Cockayne, Ray, (address unknown)	11.80	"	"
Wilkins, W., (address unknown)	11.80	"	"
Cheetham, B., 130 Middleborough Rd, Blackburn South	19.22	"	2.12.77
Ryan, M., (Mrs), (address unknown)	10.00	"	"
Nicoletti, S., 9 Polaris Dr, Sale	12.77	"	"
Williams, D. J. (Mrs), (address unknown)	11.80	"	"
Oliver, C., (address unknown)	10.70	"	28.11.77
Fischer, Norm, (address unknown)	26.10	"	"
Horne, D. J., (address unknown)	26.10	"	"
Rumanauskas, S. (Mrs), (address unknown)	11.80	"	30.11.77
McGill, J., (address unknown)	10.70	"	"
Adcock, F. E. and G. M., 3 Emerton St, Evatt, A.C.T.	15.60	"	"
Dickie, E., (Mrs), (address unknown)	10.70	"	24.11.77
Cochrane, M. and Keinan, B., (address unknown)	11.80	"	25.11.77
Dodds, L. and R., (address unknown)	10.70	"	"
Stadnikoff, M. and Dufoulon, M., (address unknown)	10.35	"	23.11.77
Burn, C., (Miss), Cox, D. C. and Northerspoon G. R., (address unknown)	10.70	"	"
Wilson, H. and Moloney, K., (address unknown)	11.10	"	"
Stone, G., (address unknown)	15.60	"	"
Conway, J. F., (address unknown)	15.10	"	21.11.77
Marshall D. and Harradine, Carmel (address unknown)	10.70	"	22.11.77
Newey, L., 208 Bay Rd, Sandringham	18.30	"	"
Murphy, E., (address unknown)	36.90	"	"
Emery, J., (address unknown)	15.60	"	"
Meese, R. A., F/2 Frazers Lane, Wangaratta	10.70	"	"
Liberato, M., 5/50 Burnley St, Richmond	11.25	"	23.11.77
Craig, T. J., (address unknown)	10.50	"	17.11.77
Pattie, A. and G., (address unknown)	18.30	"	"
Young, M., (address unknown)	18.30	"	"
Chafer, V., (address unknown)	11.10	"	"
Purtell, B., (address unknown)	10.70	"	19.11.77
Graczyk, M., (Mrs), (address unknown)	10.70	"	21.11.77
Figuroa, G., (address unknown)	15.10	"	"
Brika and Helga, 430 Springvale Rd, Glen Waverley	10.82	"	7.11.77
Doyle, L., (Mrs), (address unknown)	10.70	"	10.11.77
Bosselmann, W., (address unknown)	11.80	"	"
Connor, T., 5 Hamilton St, Brisbane	10.70	"	"
O'Connell, E. P., (address unknown)	12.15	"	11.11.77
Young, M., 3 Shaw Ave, Richmond	13.67	"	16.11.77
Patterson L. and Galley, R., c/o Granny Davis Bread, Cape St, Heidelberg	11.30	"	17.11.77
Glass, I. J., 15 Victoria St, St. Kilda	11.30	"	31.10.77
Currie, K., (Mrs), 43 Alex Ave, Moorabbin	31.62	"	2.11.77
Bodgen, B., (Mr and Mrs), (address unknown)	11.10	"	3.11.77
Lloyd, H. E., (estate of), 121 Blyth St, Brunswick	11.10	"	"
Prato, Phyllis, (address unknown)	18.30	"	"
Lafey, D., (Miss), (address unknown)	11.10	"	"
Eyles, J. H., (address unknown)	15.10	"	26.10.77
Smith, D. and E., (address unknown)	15.10	"	27.10.77
Hardiman, Noel, (address unknown)	25.30	"	28.10.77
Michael, H. I., (address unknown)	26.60	"	31.10.77
Abbott, W. G., 12 Tarata Dve, Doveton	11.80	"	"
Gerlactt, H., (Mrs), (address unknown)	22.20	"	"
Lake, T., (address unknown)	10.35	"	"
Cullen, M., 70 Hammomd Rd, Dandenong	15.10	"	20.10.77
Bavorie, T., 18 Maddock St, Footscray	11.10	"	"
Moyle, A., 11-13 Ester Cres, Croydon	13.67	"	"
Stevenson, David, 13 Daly St, Frankston	11.50	"	21.10.77
McGillivray, G. D. J., 2/7 Leslie St, Richmond	13.67	"	"
Handley, Ed, (address unknown)	49.50	"	25.10.77
Geradts, W., (address unknown)	18.30	"	18.10.77
Pino, M., (address unknown)	19.50	"	"
Setschnjak, Dusanka, (address unknown)	29.65	"	19.10.77
Seetgh, A., 1/57 Chapel St, St Kilda	14.05	"	20.10.77
Gorman, B., Box 138 Moonah, Hobart, Tas.	13.67	"	"
Pamil, 483 Warrigal Rd, Ashwood	20.87	"	"
Robertson, M. (Mrs.), 8/11 Jackson St, St Kilda	22.70	"	14.10.77
Barker, J., 161 Gordon St, Footscray	14.05	"	"
Harvey, D. (Mrs.), 239 Bourke St, 1st Floor, Melbourne	11.80	"	"
Kouzmenko, B., 30 Fairhills Pde, Glen Waverley	11.80	"	"
Thompson, A. R., (address unknown)	19.50	"	"
Adkins, N. W., (address unknown)	10.00	"	"
Hoare, M., (address unknown)	20.05	"	13.10.77
Jurgen, M., 5760 Warrego Mine, Tennant Creek, N.T.	29.65	"	"
Harris, Michael, (address unknown)	14.05	"	"

## Unclaimed Moneys Act 1962

Register of Unclaimed Moneys held by the—

Name of Owner on Books and Last Known Address	Total Amount Due to Owner	Description of Unclaimed Money	Date when Amount first became Payable
§			
THE ESTATE OF THE LATE GEORGE ADAMS—continued			
Kermond, D. (Mrs.), (address unknown)	13.85	Dividend	10.10.77
Aomons, S., 145 Sydney Rd, Brunswick	14.05	"	"
Care, M. L., (address unknown)	14.05	"	11.10.77
Best, S. (Miss), 27/7 Hilltop Cres, Ivanhoe	27.55	"	"
Smith, B. S., (address unknown)	22.20	"	"
Bell, Cheryl, Lot 5, Yea Rd, Dixons Creek	10.35	"	12.10.77
Shanahan, P. N., 1 Ingor St, Ararat	22.10	"	"
McGarrity, John, 2/15 Cochrane St, Brighton	17.20	"	"
Mayer, T. and Hall T., (address unknown)	46.62	"	"
Heron, V., (address unknown)	19.50	"	7.10.77
Heron, V., R.E.H., Traralgon	19.50	"	"
Culibrk, B., SMQ, Rosebery, Tas.	35.65	"	"
Lane, J. and Evans, L., (address unknown)	25.30	"	"
Furlow, J., (address unknown)	10.35	"	10.10.77
Lovell, M. (Mrs.), (address unknown)	11.50	"	"
Kaltzis, N., (address unknown)	10.35	"	"
Dans, I., 4/74 Rathmines Rd, Fairfield	30.30	"	6.10.77
Groth, H. and C. O., (address unknown)	11.00	"	"
Pollard, A. J. and R. M., (address unknown)	11.00	"	"
Palmer, G., 4 The Gums, Mt Clear	10.85	"	"
Wyatt, R. and Grabashe, B., 27 McKenzie St, Seaford	25.07	"	"
Lang, E., 800 Torrens Rd, Rosewater, S.A.	24.80	"	"
Baker, M. R. (Miss), 9/197 Lennox St, Richmond	23.47	"	7.10.77
Koza, A. and P., 36/7 Ridleu St, Sunshine	10.35	"	"
Coyle, E. E., (address unknown)	11.50	"	3.10.77
Hammond, Jim, (address unknown)	24.10	"	"
Lowe, Noel, (address unknown)	10.00	"	5.10.77
Papasirow, (Mr. and Mrs.), (address unknown)	14.05	"	28.9.77
Fenton, J. (Mrs.), (address unknown)	22.20	"	29.9.77
Allen, K., 114 Albert Rd, South Melbourne	14.05	"	"
Rogers, C., (address unknown)	10.35	"	30.9.77
Millwood, L., (address unknown)	24.80	"	"
Gorrie, G. and McAuliffe, D., (address unknown)	26.55	"	"
Baker, G., 7/233 Brighton Rd, Elwood	19.50	"	23.9.77
Feeney, T., (address unknown)	25.30	"	"
Engel, A. R., (address unknown)	24.85	"	"
Howell, M. P., (address unknown)	11.05	"	"
Steel, A., (address unknown)	16.70	"	"
Nash, K., (address unknown)	14.65	"	28.9.77
Welker, A., (address unknown)	14.05	"	20.9.77
Sims, T., (address unknown)	14.65	"	"
Humphreys, F. L., (address unknown)	14.65	"	"
Brooks, P., (address unknown)	14.65	"	"
Uchtman, G., (address unknown)	11.80	"	21.9.77
Stuart, B. and Barwick, P., (address unknown)	11.80	"	23.9.77
MacTaggart, Max, 6 Gant St, Colac	36.00	"	"
Richards, K. and D., (address unknown)	26.55	"	22.9.77
Erceg, Josip, (address unknown)	25.30	"	15.9.77
Oregan, J., (address unknown)	25.30	"	16.9.77
Bordink, C., (Mrs), (address unknown)	14.05	"	19.9.77
Gallagher, Chris, (address unknown)	33.25	"	"
Ridings, J. A., (address unknown)	22.20	"	"
Doherty, I. and A., P.O. Box 454, Redcliffs	17.20	"	13.9.77
Chippendall, M., (address unknown)	21.15	"	14.9.77
Farmer, A. F., (address unknown)	16.55	"	"
Maccioli, A. J., c/o Atkinson Holland, Upper Thomson	19.50	"	"
Hewa, W., (address unknown)	19.50	"	15.9.77
Gegg, S. and O'Brien, P., (address unknown)	14.05	"	"
Callaghan, J. and S., (address unknown)	11.50	"	8.9.77
William, F., Box 62, Savage River, Tas.	28.50	"	9.9.77
Boswell, E. C., (address unknown)	21.15	"	12.9.77
Millar, V., 106 Clarendon St, Ballarat	21.70	"	"
Attenborough, Alf, (address unknown)	10.00	"	"
Blease, K. A., Yarra Glen	29.35	"	13.9.77
Mackay, T., 4 Murtoa St, Dallas	29.35	"	6.9.77
Tivendale, C. (Mrs), (address unknown)	29.35	"	1.9.77
Ollivier, (Mr and Mrs), 1/61 Davies Ave, South Yarra	10.00	"	2.9.77
Forbes, J., 29 Coventry St, South Melbourne	17.20	"	7.9.77
Rulle, T., 583 Elizabeth St, Melbourne	21.70	"	"
Hooper, P., (Miss), 96 Plume St, Norlane	29.35	"	"
Counahan, G., (address unknown)	10.45	"	"
Westerink, A., 1/38 Creswick St, Hawthorn	11.40	"	"
Doherty, John, Lot 7, Covens Lane, New Gisborne	25.10	"	"
Cameron, I. D., 80 Skene St, Newtown	33.70	"	2.9.77
Carroll, Peter, 176 Nobles St, Newtown	11.30	"	"
McKenna, E., (Mrs), (address unknown)	20.05	"	"

## Unclaimed Moneys Act 1962

## Register of Unclaimed Moneys held by the—

Name of Owner on Books and Last Known Address	Total Amount Due to Owner	Description of Unclaimed Money	Date when Amount first became Payable
\$			
THE ESTATE OF THE LATE GEORGE ADAMS—continued			
Dickins, P., (address unknown)	10.00	Dividend	5.9.77
Smith, L., P.O. Merbein	49.50	"	6.9.77
Harrison, Peter, (address unknown)	20.05	"	"
Lozag, P., 230 Belmore Rd, Balwyn	29.35	"	"
Grey, Betty, 80 Heytesbury St, Herne Hill	10.60	"	29.8.77
Watson, B. R. and M. R., 55 Meakin St, Watsonia	11.50	"	31.8.77
McLear, R. T., 1/52 Arlington St, Ringwood	16.35	"	1.9.77
Milutin, S., 5 Mawson Crt, Mulgrave	23.65	"	"
Milutin, Svetin, (address unknown)	17.20	"	"
Kerr, N. H., 58 Maple Ave, Wendouree West	12.75	"	"
McAndrew, Warren, Bas Radio, R.A.A.F. Base, East Sale	10.00	"	"
Lendwry, P., 8-822 Heatherton Rd, Springvale	29.35	"	"
Lowcock, P. S., (address unknown)	18.00	"	22.8.77
Macey, P., 11 Cherry Tree Rd, Hurstbridge	17.20	"	25.8.77
Lubcke, E., 462 Kyrie St, Geelong	19.50	"	"
Harding, G. A., (address unknown)	30.30	"	"
Forsth, J. and Finemore, G., (address unknown)	10.60	"	26.8.77
Downs, Byaduk	22.10	"	18.8.77
Manley, P., (address unknown)	10.60	"	19.8.77
Reed, A., (address unknown)	11.30	"	"
Clay, S., (address unknown)	13.20	"	"
Lowcock, P., (Mrs), (address unknown)	31.25	"	22.8.77
Young, A. M., (Mrs), 46 Cluden St, Brighton East	11.30	"	11.8.77
Kuronen, K., (Mrs), 2/6 Enderby St, Mawson	11.50	"	"
Spencer, J., (address unknown)	11.50	"	12.8.77
Goldman, P., 50 Burrindi Rd, South Caulfield	11.50	"	"
Francesca, Nina Maria, (address unknown)	11.50	"	"
Trigg, C. W., (address unknown)	20.05	"	15.8.77
Kempe, I. D., (address unknown)	10.60	"	16.8.77
Congelo, H., 143 Broadway, Dunolly	16.35	"	3.8.77
Nightingale, G. V. and Jolly, L., (address unknown)	10.00	"	"
Kiss, S., (address unknown)	13.05	"	"
Crozier, B. E., (address unknown)	10.80	"	4.8.77
Cooper, G., 14 Ross Ave, Launceston, Tas.	10.60	"	5.8.77
Levere, V., P.O. Morwell	20.30	"	"
Martyn, A. C., 102 Hunter St, Deniliquin, N.S.W.	10.60	"	8.8.77
May, J. and R., (address unknown)	11.30	"	11.8.77
Heywood, I., (address unknown)	10.00	"	"
Richard, K. W., (address unknown)	20.05	"	27.7.77
Stevens, John, Lot 1 Nelson Rd, Lilydale	11.30	"	28.7.77
Harrington, G., 784 Raglan P.O., Warrnambool	22.70	"	"
Smith, A., (address unknown)	19.50	"	"
Elkins, P., (address unknown)	10.00	"	21.7.77
Mannerine, J., (address unknown)	11.30	"	"
Sutherland, L., (address unknown)	22.10	"	15.7.77
Carello, Nick, (address unknown)	12.60	"	18.7.77
Bena, M., Wyndham St, Shepparton	19.42	"	12.7.77
McFarlane, A., (address unknown)	18.00	"	7.7.77
Munyard, M. (Mrs.), 4 Toorak Rd, South Yarra	10.50	"	"
Riches, N. (Mrs.), 4 Grant Ave, Werribee	10.00	"	8.7.77
Ivanusic, M., 12 Deanswood Close, Wantirna South	10.25	"	11.7.77
Guthrie and Welsh, (address unknown)	11.60	"	5.7.77
Borzini, B., (address unknown)	15.50	"	6.7.77
Stevens, B., Ballarat Police	23.05	"	"
Burns, D., 85 Woods St, Donald	18.00	"	30.6.77
Busuttic, E., (address unknown)	38.90	"	"
Parish, L. (Mrs.) and Family, (address unknown)	14.55	"	1.7.77
Sheppard, K. J. (Mr. and Mrs.), 49 Kidman St, Yarraville	11.60	"	29.6.77
McDonell, Ron, (address unknown)	19.50	"	"
Francis, Anne, 2 Breen St, Bendigo	13.50	"	"
Speer, T. P., 50 Keck St, Bendigo	23.20	"	30.6.77
Speer, T. P., (address unknown)	20.37	"	"
Cox, L. and C., P.O. Last Barrow, Tas.	11.02	"	24.6.77
Cox, L. and C., (address unknown)	36.50	"	"
Mildren, H., (address unknown)	23.05	"	27.6.77
Shaw, A., (address unknown)	11.40	"	28.6.77
Krushka, K. (Mrs.), Barnett Cres, Bridport, Tas.	10.85	"	"
McKenzie, J. B., 45 Victoria St, Kerang	22.35	"	22.6.77
Fitzpatrick, D. J., 19 Locksley St, Wendouree	10.25	"	23.6.77
Booth, J. T., (address unknown)	22.10	"	24.6.77
Burney, A. (Mrs.), (address unknown)	16.50	"	"
Burke, W., (address unknown)	15.10	"	"
Laird, H. M., Anakie P.O., via Geelong	22.35	"	"
Lourey, D. M., (address unknown)	25.30	"	"
Wallace, J. K., 27 Guthrie Ave, Nth. Geelong	11.40	"	"
Barbieri, I., 5/12A Gilbert St, Cabramatta, N.S.W.	22.35	"	17.6.77



## Unclaimed Moneys Act 1962

Register of Unclaimed Moneys held by the—

Name of Owner on Books and Last Known Address	Total Amount Due to Owner	Description of Unclaimed Money	Date when Amount first became Payable
\$			
THE ESTATE OF THE LATE GEORGE ADAMS—continued			
Scherger, N. J., 289 Station St, Chelsea	13.50	Dividend	20.6.77
Boyer, H. J., 268 Beechworth Rd, Wodonga	24.05	"	21.6.77
Jeffery, Paula, (address unknown)	10.25	"	"
Rouse, R., (address unknown)	11.40	"	"
Joyce, F. P., (address unknown)	47.70	"	22.6.77
Shields, Kelly, Harper, Moles, Michael Granter, (address unknown)	15.60	"	13.6.77
Wiggins, D. M., 23 Wellington R.J, Lindisfarne	22.35	"	14.6.77
McEwan, Michelle F., (address unknown)	29.50	"	15.6.77
Suey, Brian A., 27 Mihil St, East Preston	10.55	"	"
Muir, Carol, 11 Station St, Fairfield	22.35	"	17.6.77
Furlong, G., (address unknown)	21.90	"	3.6.77
Culjak, C. M., (address unknown)	11.60	"	7.6.77
Edge, W. E., 12 Lorine Pde, Broadford	11.42	"	8.6.77
Dand, R., c/o Royal Hotel, Daylesford	26.92	"	"
Gungor, R., 4/2 Scarborough Dr, Moorabbin	19.50	"	9.6.77
Frew, E. J. (Mr and Mrs), Box 172 Rainbow c/o P.O., Yaapeet	15.42	"	27.5.77
Coppin, W. A. and Brown, R. W., Lot 4 Clover St, Wendouree	19.50	"	1.6.77
Horder, L., 17 Corrigan St, Balwyn	39.95	"	"
Winch, C. P. R., 28 Longstaff St, Shepparton	12.70	"	2.6.77
Winch, R., (address unknown)	23.15	"	"
Doyle, S. M. (Miss), 84 Powercourt St,	12.20	"	"
Kenden, D., Newstead	25.62	"	20.5.77
Bradford, F., Corrigan Park, Deniliquin, N.S.W.	14.97	"	"
Cole, A. R. and Mills, R. J., (address unknown)	12.60	"	26.5.77
McBride, G. R., (address unknown)	12.90	"	27.5.77
Hoernlein, A. and Pennetather, R., P.O. Box 480, Dandenong	37.90	"	"
Austin, I. (Mrs), (address unknown)	11.60	"	"
Lawler, R., (address unknown)	12.60	"	13.5.77
Mansek, M. S., 3/13-15 Glamis St, Newtown, Geelong	24.05	"	17.5.77
Orr, H., (address unknown)	12.90	"	"
Long, U. R., (address unknown)	19.05	"	"
English, R., (address unknown)	12.60	"	"
Richardson, A., (address unknown)	12.90	"	18.5.77
James, W. E. (estate of), 83 Orlando St, Hampton	15.85	"	"
Stathousis, Joanna, 15/102 Park St, St Kilda	10.55	"	"
Seewitz, Bruce, (address unknown)	16.50	"	"
Kemp, T., (address unknown)	21.90	"	"
Kennard, T., (address unknown)	11.60	"	6.5.77
Howell, A. P. and Co., (address unknown)	10.00	"	"
Gorman, M. (Mrs), (address unknown)	12.90	"	9.5.77
Keller, S. A., (address unknown)	12.90	"	"
Cameron, M. J. (Mrs), Ballangeich, West Ellerslie	11.92	"	"
Smith, J. (Mrs), (address unknown)	11.60	"	10.5.77
Stone, L., (address unknown)	11.40	"	12.5.77
Stone, L. and G., (address unknown)	30.55	"	"
Smith, C. L., 6 Ethel Crt, Springvale	10.00	"	13.5.77
Pain, John, 196 Sherbourne Rd, Montmorency	10.00	"	"
Angus, R. A., (address unknown)	21.90	"	2.5.77
Eaton, B. (Mrs), 7 Cobby St, Laverton	11.60	"	"
Harrington, M., (address unknown)	13.50	"	3.5.77
Watters, Robert, 300 Albert St, Brunswick	10.85	"	4.5.77
Kovacik, M. A., (address unknown)	11.90	"	"
Armstrong, R., 492 St Kilda Rd, Melbourne	11.60	"	5.5.77
Kennedy, P., (address unknown)	10.00	"	"
Tramontana, P., 355 Francis St, Yarraville	12.90	"	"
Camden, L., (address unknown)	11.60	"	6.5.77
Howard, Kevin, Box 144 Traralgon	12.75	"	28.4.77
Watkins, Claire, (address unknown)	25.10	"	"
Johnson, L., (address unknown)	10.25	"	"
Kitchin, M. L. (Mrs), (address unknown)	10.25	"	"
Robinson, Jan, 4/235 Riversdale Rd, East Hawthorn	23.02	"	"
Dempster, M. and Warnecke, R., 4/56 Dunstan Pde, Campbellfield	11.62	"	"
Francis, E. G., (address unknown)	13.75	"	"
Colac Training Centre, Forest St, Colac	23.02	"	29.4.77
Schilg, Hedley, (address unknown)	17.70	"	"
Smethurst, S., (Mrs), 6/20 Rathmines St, Fairfield	12.20	"	25.4.77
Smyth, John M., 25 Bonview Ave, Ringwood	24.00	"	26.4.77
Webster, D., 104 Gore St, Fitzroy	10.00	"	"
Webster, D., (address unknown)	10.00	"	"
Arnott, E. L., (address unknown)	10.00	"	"
Rowell, L. J., (address unknown)	10.00	"	27.4.77
Hill, Barry K., (address unknown)	10.25	"	20.4.77
MacLean, G. G., Braxholme	16.80	"	21.4.77
Hitchcock, L., (address unknown)	28.25	"	"
Gilmore, Paul, (address unknown)	15.85	"	"
Weisl, Eva, (address unknown)	10.00	"	"

## Unclaimed Moneys Act 1962

## Register of Unclaimed Moneys held by the—

Name of Owner on Books and Last Known Address	Total Amount Due to Owner	Description of Unclaimed Money	Date when Amount first became Payable
S			
THE ESTATE OF THE LATE GEORGE ADAMS—continued			
Jehu, J., P.O. Box 189, Camperdown	11.15	Dividend	22.4.77
Hooke, R., (address unknown)	22.95	"	"
Vila, Alonso, c/o Dartmouth P.O., Dartmouth	19.50	"	20.4.77
Hall, D., (address unknown)	10.00	"	"
Woodward, P. (Mrs), (address unknown)	28.25	"	"
Tanner, P., (address unknown)	10.25	"	"
Metz, A., (address unknown)	23.35	"	"
Carlson, V., (address unknown)	12.20	"	"
Hodges, B. and V., 20 Gwendoline Ave, Bendigo	23.20	"	"
Salce, F. and Carter, P., 38 Burton Cres, East Ivanhoe	11.62	"	"
Dias, H., (address unknown)	10.00	"	18.4.77
Glover, G., Bendigo P.O., Bendigo	24.85	"	"
Bickerton, J., (address unknown)	25.10	"	"
Brust, W., 5 Bradfield St, Downer, A.C.T.	22.95	"	"
Pezzatti, R. and Storgato, D. and Duturolo, G., (address unknown)	10.85	"	"
Sharp, P.O. Branhholme	23.82	"	19.4.77
Matthews, A., (address unknown)	11.15	"	"
Guglielmi, Tamara, F/2 Edward St, Cobden	17.65	"	"
Burr, J. L., Box 339, 3 Alexander St, Warragul	14.00	"	"
Hooper, M. J., (Mr and Mrs), (address unknown)	10.87	"	"
Bainbridge, A., 76 Coomora Rd, Springvale	10.35	"	20.4.77
Kvesic, P., (address unknown)	17.70	"	14.4.77
Tatti, Cheryl, (address unknown)	17.70	"	"
Rearon, M. (Mrs), (address unknown)	10.00	"	15.4.77
Morley, R., (address unknown)	12.75	"	"
Hammond, B. and King, D., (address unknown)	10.00	"	"
Zapadiototis, M., 2/22 Ambrie Cres, Noble Park	11.15	"	"
Millar, P., 369 St. Helena Rd, Greensborough	10.92	"	"
Mosley, J., (Mrs), 1/201 Punt Rd, Richmond	19.50	"	"
Lobello, Vinanto, 3 Elgin St, Morwell	20.55	"	"
Hill, R., (address unknown)	10.00	"	13.4.77
Joiner, M. R., (address unknown)	10.00	"	"
Bruninsma, L., (Mrs), F/7, 44 Beaumaris Pde, Highett	17.70	"	"
Bruinsma, L., (Mrs), (address unknown)	17.70	"	"
Rowland, R., (address unknown)	16.80	"	14.4.77
Humphrey, Peter, (address unknown)	10.00	"	"
Nedeljkovic, S., (address unknown)	16.80	"	6.4.77
McCormack, J., (address unknown)	10.00	"	"
Micallef, J., 26 Boyd St, Dandenong	13.75	"	7.4.77
Verdonck, Marie T., (Mrs), 37 Nathan St.	10.32	"	12.4.77
Mont, Greg, Eldorado P.O., Eldorado	24.15	"	"
Mont, Greg, (address unknown)	17.97	"	"
Young, B. E., 64A Lexton Rd, Box Hill	10.00	"	"
Student, B., 185 Cunningham St, Sale	27.87	"	"
Walden's Home Appliances, 37 Slevin St, North Geelong	10.00	"	"
Bonser, L., c/o Southside Caravan Park, A.C.T.	24.85	"	4.4.77
Hamilton, B., (Mrs), Erang Dve, Mt. Eliza	10.00	"	"
Martin, D., (Mrs), (address unknown)	20.55	"	5.4.77
Baldwin, Peter, c/o Cotswold Park, Mathoura, N.S.W.	25.10	"	"
Baldwin, Peter, (address unknown)	21.90	"	"
Chan, Kok Sing, (address unknown)	23.65	"	"
Doherty, F., (Mrs), (address unknown)	10.00	"	6.4.77
O'Shannessy, M. J., (address unknown)	10.00	"	"
Barnes, Graeme, (address unknown)	24.00	"	31.3.77
Rose, R., (address unknown)	23.20	"	1.4.77
Nutt, Annette, (Miss), (address unknown)	10.00	"	"
Mercovich, P. and McComb, R., (address unknown)	27.60	"	"
Harris, K. and T., (Misses), (address unknown)	10.00	"	"
Carpi, N., 22 Sage St, East Oakleigh	10.00	"	4.4.77
Jason, W. and G., 32 Carter Ave, Werribee	24.85	"	30.3.77
Athey, M. A., (Mrs), 8 Granville St, Glenroy	12.75	"	"
Holmes, R. T. and B., F/3 1021 Grevillea Rd, Wendouree	13.65	"	"
Romero, J., Enterprise Hostel, Springvale	26.80	"	31.3.77
Gyrry, J., 49 Thanet St, Malvern	13.80	"	"
Tibballs, M., Fish Creek	13.80	"	"
Jackson, H. B., (address unknown)	10.95	"	"
Jackson, H. B., Fitzsimmons Lane, Templestowe	13.75	"	"
Ahearn, M., 78 Queens Ave, Carnegie	24.10	"	28.3.77
Hunter, D. (Mr. and Mrs.), (address unknown)	11.15	"	"
Santa, W. S. C. H., c/o Bid, 1/28 Young St, Frankston	18.50	"	"
Swindle, R. and Anthony, M., (address unknown)	10.05	"	"
Kerr, K., Lot 7, Queen St, Wallan	13.75	"	29.3.77
Tavrou, C., 169 Keilor Rd, North Essendon	20.50	"	"
Pearse, J., Army App's School, Balcombe	12.75	"	"
Tanner, J. J., 1113 Glenhuntly Rd, Glenhuntly	24.00	"	29.3.77

## Unclaimed Moneys Act 1962

## Register of Unclaimed Moneys held by the—

Name of Owner on Books and Last Known Address	Total Amount Due to Owner	Description of Unclaimed Money	Date when Amount first became Payable
§			
THE ESTATE OF THE LATE GEORGE ADAMS—continued			
Cooke, R. A., P.O. Pyalong	24.50	Dividend	30.3.77
Wood, Ian F., (address unknown)	21.00	"	"
Scotson, J. (Mrs.), (address unknown)	10.00	"	23.3.77
Kneebone, A. J., (address unknown)	16.80	"	"
Capon, P. M. (Mrs.), 6 Dunravin Crt, Frankston	17.70	"	24.3.77
Name and address unknown	10.00	"	25.3.77
Chalmers, A., 4 Cuiznola Ave, Doncaster	24.95	"	"
Devenney, W. (Mr. and Mrs.), 3/5 Browning Ave, Westall	22.95	"	"
Ahmad, Maamor, (address unknown)	23.25	"	28.3.77
Mifsud, J. and Briffa, T., 129 Dryburgh St, North Melbourne	11.15	"	18.3.77
O'Brien, B., (address unknown)	11.15	"	"
McNally, Stella M., 2/32 Barkly St, Sunbury	13.75	"	"
Bartlett, S. J., (address unknown)	24.00	"	"
Kenny, A. J., (address unknown)	10.00	"	21.3.77
Sailor, Ruth (Mrs.), (address unknown)	10.00	"	22.3.77
Condon, P., (address unknown)	13.75	"	23.3.77
Hoare, Trevor, (address unknown)	13.75	"	10.3.77
Keam, A. R., 11 Upper Roy St, Jeparit	17.42	"	"
Eritin, N., 27 Gladwyn Ave, East Bentleigh	27.60	"	"
McAfee, Margaret J., (address unknown)	10.55	"	"
Forbes, R. (Mrs.), (address unknown)	24.00	"	"
Friend, A. P., 5 Cross St, Canterbury	23.70	"	11.3.77
Turner, K. (Mrs.), Percy St, Carrick, Tas.	10.00	"	"
Zappia, Don, Ontario Ave, Mildura P.O.	22.35	"	15.3.77
Hutcheon, L. M. (Mrs.), 20 Garnsworthy St, Springvale	19.50	"	17.3.77
Robertson, Philip John, (address unknown)	24.00	"	"
Lay, G. N., Jennifer St, Cranbourne	19.50	"	3.3.77
Day, V. and D., 168 Bay Rd, Sandringham (unit 2)	10.85	"	4.3.77
Russell, D. S., 13 Trudgeon Ave, Regent	10.85	"	"
Landy, W. L. (Mrs.), (address unknown)	17.65	"	7.3.77
Lawrence, R. E., (address unknown)	11.15	"	8.3.77
Love, K. (Mr. and Mrs.), F/5, 487 Rylie St, East Geelong	22.35	"	"
Phillips, L. K., (address unknown)	22.35	"	"
Pajvancic, Petar, (address unknown)	10.85	"	9.3.77
Gibbons, P. A. J., (address unknown)	12.75	"	"
Richards, Ray, 14 Adelaide St, Sunshine	17.70	"	10.3.77
Nicola and Amando, 20 Regent St, Coburg	17.70	"	"
Williams, Heather L., 32 Ray St, Sale	10.85	"	24.2.77
Jenkins, A. C., c/o H.M.A.S. Fremantle, W.A.	49.50	"	25.2.77
Cannard, E., (address unknown)	10.00	"	"
Murphy, H. and J., (address unknown)	24.85	"	2.3.77
McQuilton, T. C., (address unknown)	20.60	"	1.2.77
Hayes, S. H. and Ritchi, A. J., 234 Forest Rd, Boronia	27.60	"	"
Porter, R., F/3 Lowell Ave, Kingsbury	27.60	"	2.2.77
Keeley, G. P., (address unknown)	14.65	"	3.2.77
Kleynjan, J. M. and Ainsch, W. A., 10 Orna St, Ferntree Gully	25.30	"	7.2.77
Smith, G., (address unknown)	22.85	"	"
Hobbs, J., 7 Brixton Ave, Eltham North	25.30	"	9.2.77
Wright, Anita, (address unknown)	10.55	"	10.2.77
Allan, M., 1713 Barnsbury Rd, South Yarra	17.65	"	11.2.77
Russell, Suzanne, 9 Anderson St, Warracknabeal	10.85	"	15.2.77
Bau, P. (Mr. and Mrs.) and Cokin, 12 Diggora Pde, Numurkah	23.37	"	16.2.77
Taylor, R. W., 140 Rathdown Rd, Reservoir	17.65	"	21.2.77
Jones, Patricia, c/o Red Cliffs, Caravan Park	11.50	"	"
Perrett, Stephen, 27 James St, Frankston	19.25	"	22.2.77
Bailey, Ken, (address unknown)	13.10	"	"
Moore, T. E., (address unknown)	21.00	"	13.1.77
Savage, C. A. and J. M., 49 Allens Rd, Heathmont	23.60	"	17.1.77
O'Connor, Rita (Mrs.), 198 Shannon Ave, Geelong West	23.60	"	"
Cunningham, J., 14 Thackeray St, Elwood	19.82	"	18.1.77
Allie, R., 1/74 Montagu St, Newtown	27.60	"	19.1.77
Jackson, G. R., (address unknown)	12.20	"	20.1.77
Kaye, H., (address unknown)	27.60	"	"
Williams, E. M., 512 Thurgood St, Albury, N.S.W.	11.35	"	10.1.77
Harding, G. A., Box 14 Goodnight, N.S.W.	14.07	"	"
Zanchetta G., (address unknown)	12.10	"	11.1.77
Marx, Josef, 25 Carrington St, Queanbeyan, N.S.W.	41.27	"	12.1.77
Andrews, J. D., P.O. Box, 164 Rep. of Nauru, Central Pacific	16.35	"	31.12.76
Thornber, L. (Mrs.), (address unknown)	22.35	"	"
Davidson, Bruce L., (address unknown)	10.95	"	4.1.77
Lewis, T. (Mrs.), (address unknown)	23.95	"	"
Yeronaig, A., 5 Watties Rd, Templestowe	10.95	"	"
Trewella, N. M., P.O. Corryong	14.07	"	"
Fisher, K. and Adams, J. and M., (address unknown)	10.32	"	"
Spokes, G. (Mrs.), (address unknown)	10.00	"	5.1.77
Name and address unknown	16.35	"	5.11.77

## Unclaimed Moneys Act 1962

## Register of Unclaimed Moneys held by the—

<i>Name of Owner on Books and Last Known Address</i>	<i>Total Amount Due to Owner</i>	<i>Description of Unclaimed Money</i>	<i>Date when Amount first became Payable</i>
\$			
THE ESTATE OF THE LATE GEORGE ADAMS—continued			
Name and address unknown	23.95	Dividend	5.11.77
Name and address unknown	23.95	"	"
Oggenovski, Ivanco, (address unknown)	10.95	"	30.12.76
Moffatt, E., (Mrs), P.O. Box 150, Drouin	39.35	"	"
Bray, Alys, (address unknown)	13.65	"	31.12.76
Gittens, Graeme, (address unknown)	31.25	"	"
Kirkwood, T. A. (Mrs), 179 Last St, Latrobe, Tas.	23.80	"	"
Cradock, T., (address unknown)	17.00	"	23.12.76
Reynolds, R., (Mrs), (address unknown)	13.65	"	"
Green, Z., (Mrs), (address unknown)	10.95	"	"
Fontonoi, R., (address unknown)	23.75	"	"
Keating, T. J., (Mrs), (address unknown)	13.80	"	24.12.76
Buer, R. W., c/o Oakleigh Police Station, Oakleigh	23.95	"	"
Wood, M. J., (address unknown)	9.50	"	"
Court, F. S., 5/1 Willana Ave, Hamlyn Heights	23.75	"	"
Name and address unknown	14.30	"	"
Name and address unknown	37.35	"	"
Buchter, B. J., 29 Learmouth St, Belmont	13.65	"	21.12.76
Person, A. J. C., (address unknown)	13.65	"	"
Costa, V., (Miss), 81 Hill Rd, North Balwyn	22.35	"	"
Gillies, A., (Mrs), (address unknown)	10.95	"	"
Heath, M. and Swales, N., 160 Overport Rd, Frankston	22.05	"	"
Chapman, Dale, c/o Sunshine Heights Hotel, Sunshine	10.50	"	22.12.76
Scoble, Ian, (address unknown)	23.35	"	"
Harrison, R., Gilbert, R., Schack, W., Curtis, J., (address unknown)	10.70	"	23.12.76
Coxon, P., (address unknown)	10.95	"	"
Gerasimovski, G., (address unknown)	11.25	"	16.12.76
Nicholls, B., (address unknown)	22.40	"	17.12.76
Dumbrell, B. W., 403 Glenferrie Rd, Malvern	21.00	"	"
Hume, G. W., (address unknown)	39.35	"	"
Millsom, B., (Mrs), (address unknown)	16.00	"	20.12.76
Millsom, B., (Mrs), (address unknown)	19.25	"	"
Green, R., (address unknown)	12.70	"	"
Smith, R. D., (address unknown)	10.50	"	21.12.76
Shannon, K. J., (address unknown)	13.10	"	14.12.76
Goodier, J., (address unknown)	24.50	"	"
Mackey, Sue, (address unknown)	13.65	"	15.12.76
Hill, George, (address unknown)	11.10	"	"
Vance, E., (address unknown)	23.95	"	"
Watson, T. P., (address unknown)	19.50	"	16.12.76
Davis, S., (address unknown)	10.70	"	9.12.76
McInerney, K. J., Box 86, Sea Lake	24.10	"	"
Lelean, Debbie, (Miss), (address unknown)	37.80	"	"
Carter, D. D., (address unknown)	38.35	"	10.12.76
Higgins, Leonie, (address unknown)	11.10	"	"
Lanc, B., (address unknown)	23.95	"	"
Di Batista, Adelmo, (address unknown)	13.65	"	"
Wilson, A. C., (address unknown)	10.00	"	6.12.76
Smith, J., c/o Bank N.S.W., 425 Collins St, Melbourne	22.67	"	"
Szperlak, Alois, P.O. Box 4827, Mary Kathleen, Qld.	10.50	"	"
White, A., (address unknown)	16.35	"	"
Barker, W., (address unknown)	23.75	"	7.12.76
Lee, J., (address unknown)	39.35	"	"
Moylan, J. D., (address unknown)	11.10	"	"
Walker, R. P., (address unknown)	23.75	"	8.12.76
Rea, W., (address unknown)	11.10	"	9.12.76
Peake, R. J., Lot 108 Overland Dve, South Vermont	10.05	"	"
Gange, M., 5 Jacaranda St, Redcliffs	11.10	"	3.12.76
Lombardo, M., 64 Keilor Rd, Nth. Essendon	11.65	"	"
Lombardo, M., 64 Keilor Rd, Nth. Essendon	24.05	"	"
Jones, Albert, (address unknown)	22.55	"	"
Carter, M. J., (address unknown)	16.00	"	"
Donald, G., P.O. Box 175, Caulfield	11.10	"	"
Bradford, N. F. and R. B., 26 Westleigh Cres, Narre Warren	31.25	"	"
Henry, C., (address unknown)	22.05	"	6.12.76
Henry, C., (address unknown)	19.00	"	"
Cremmins, Fran, (address unknown)	10.45	"	30.11.76
Butler, V., 9 Borang St, Coburg	11.30	"	1.12.76
Colgen, Frank, F/7 26 Rushall St, Fairfield	24.95	"	"
Smith, P., 108 Beach Rd, Sandringham	10.05	"	2.12.76
Sims, J., and Catterall, P. J., 83 Hammett St, Carrajong	23.60	"	"
Dafovski, Risto., (address unknown)	10.32	"	25.11.76
Sunderland, J. M., (address unknown)	22.67	"	"
Bsaras, 34 Leyland Rd, Mt. Waverley	16.35	"	26.11.76
Gower, Sharon., 31 Henrietta Gve, West Lon	13.10	"	"
Carver, H. T., 1/2 Wells Rd, Beaumaris	11.30	"	"

## Unclaimed Moneys Act 1962

## Register of Unclaimed Moneys held by the—

Name of Owner on Books and Last Known Address	Total Amount Due to Owner	Description of Unclaimed Money	Date when Amount first became Payable
\$			
THE ESTATE OF THE LATE GEORGE ADAMS—continued			
Hoyle, J., (Mrs), 446 Warrigal Rd, Ashburton	10.05	Dividend	26.11.76
Whitwell, A., (address unknown)	10.32	"	29.11.76
Hunt, Len., (address unknown)	24.10	"	15.11.76
Moses, R. and Weight, K. M., (address unknown)	13.10	"	18.11.76
O'Neil, B., 15 Bristol St, East Bentleigh	19.55	"	23.11.76
O'Neil, Brian, 15 Bristol St, East Bentleigh	39.90	"	"
Flynn, M., 4 Vicki Crt, Doncaster	11.10	"	25.11.76
Leonard, John, 636 St. Kilda Rd, Melbourne 6203	14.30	"	"
A.C.I. PLASTICS MOORABBIN			
Woo, C. T., 16 Steele St, Moonee Ponds	70.85	Wages	5.4.78
Williams, M., 90 Kirkham Rd, Springvale South 6031	73.65	"	16.11.78
AUSTRALIAN GLASS MANUFACTURERS COMPANY			
Mihajlovic, J., 113 Ashley St, Braybrook 6032	18.59	Wages	—3.78
A.C.I. PERSONAL SECURITY FUND			
Hadar, A., 137 Livingstone Rd, Marrickville, N.S.W.	20.16	Refund	8.3.78
Johnson, P. V., c/o P.O. Dunwich North, Stradbroke Island, Qld.	150.72	"	"
Strong, J., c/o P.O. Dunwich, Stradbroke Island, Qld.	18.00	"	"
Ivanovski, K., 29 Unwins Bridge Rd, St Peters, N.S.W.	19.04	"	10.4.78
Cauchi, C., 53 Hilma St, West Sunshine	29.12	"	26.4.78
Akbaba, A., 6/28 Bray St, Erskineville, N.S.W.	10.08	"	1.5.78
Kyriacov, N., 549 Bourke St, Surrey Hills, N.S.W.	18.84	"	23.5.78
Sarcak, L., 37 Fairmont St, Dulwich Hill, N.S.W.	21.98	"	9.6.78
Caliskan, M., 8/33 James St, Enmore, N.S.W.	11.20	"	6.7.78
Teague, P., 62 Boundary Rd, Liverpool, N.S.W.	36.00	"	"
Veljanovski, S., 37 Denison St, Arncliffe, N.S.W.	68.40	"	"
Milavanova, J., 15/77 Liverpool Rd, Summerfield, N.S.W.	210.00	"	"
Sollati, H., 36 Studd Rd, Dandenong	10.08	"	24.7.78
Wiebrands, W., 21 Stoke St, White Gum Valley, W.A.	33.60	"	21.8.78
Karabet, B., formely C. Balemian, 10 Hill St, Hurlstone Park, N.S.W.	96.07	"	11.9.78
Hussein, M., 12 Denkin St, Yarraville	14.56	"	6.11.78
Malikovski, Z., 8 Haresta Ave, Dandenong	43.68	"	31.10.78
McKean, A. J., 37 Fleming Rd, Herston Qld.	27.90	"	28.11.78
Demetrovski, S., 2/4 King Edward St, Rockdale, N.S.W.	18.90	"	2.1.79
Taylor, A. G., 13 Nurdi St, Woodridge, Qld.	56.00	"	31.1.79
Alievski, G., 50 Dawn Ave, Dandenong	36.96	"	5.2.79
Saylav, S., 6/16 Schild St, Yarraville 6033	62.10	"	26.2.79
ELDER SMITH GOLDSBROUGH MORT LIMITED			
Smith, W. G. and G. L., Commercial Hotel, Box 36, Barellan	164.99	Stock Proceeds	31.7.78
Kinghorn, J., Box 481, Hamilton	168.61	" "	1.11.78
Jones, Max, Bridge St, Benalla	20.48	Cartage	21.12.78
Kelly, R. L., Nullawil	40.60	Agistment	28.11.78
Kilburn, R., (address unknown)	14.32	Clear Account	26.9.78
O'Brien, J. L., (address unknown)	34.00	" "	20.6.78
Paramatta Enterprises, Lot 27, Braemore Park, Merriang Rd, Whittlesea	411.25	Rent	9.3.78
Name and address unknown	46.15	Stock Proceeds	16.5.78
Name and address unknown	15.70	" "	21.6.78
Name and address unknown	15.84	" "	21.9.78
Name and address unknown	13.74	" "	1.11.78
Name and address unknown	51.32	" "	16.2.79
6034			
COMMERCIAL UNION ASSURANCE COMPANY OF AUSTRALIA LTD.			
Lowe, B., c/o Stockdale Prospecting Ltd., Lot 605, Konkerberry Dr, Kununarra, W.A.	108.00	Claim	22.11.78
Kildea, T., c/o John Sinnott, Camperdown Computer Service, Box 74, Camperdown	39.52	Premium	5.12.78
Tuff Footwear Pty. Ltd., Box 59, G.P.O. Sydney, N.S.W. 6209	146.84	"	15.12.78
UNION ASSURANCE SOCIETY OF AUSTRALIA LIMITED			
Baillieu Bowring (Vic.) Pty. Ltd., 44 Market St, Melbourne	102.00	Claim	30.12.77
Keane, N., 33 Illawarra Cres, Bayswater North	86.56	"	10.7.78
Marcolin, E., 66 Stewart Gve, Broadmeadows	20.50	"	30.11.78
D. M. Stacey Panelworks, Caldundra Rd, Caldundra, Qld. 6210	163.50	"	1.12.78

## Unclaimed Moneys Act 1962

## Register of Unclaimed Moneys held by the—

Name of Owner on Books and Last Known Address	Total Amount Due to Owner	Description of Unclaimed Money	Date when Amount first became Payable
\$			
AUSTRALIAN CONSOLIDATED INDUSTRIES LIMITED			
Aitchison, John A., c/o Happy Bee Apiaries, Orino R.D.2., Taupiri, N.Z.	10.20	Dividend	— 8.78
Allan, Ronald R., Flat 4, 10 Parkville St, Chermside, Qld.	27.00	"	— 2.79
Allen, Sidney J., c/o 79 Nelson St, Opotiki, N.Z.	367.20	"	— 8.78
Alston, Thomas D. D., Yanrey Station, Carnarvon, W.A.	114.96	"	— 2.79
Aspland, Peter J., P.O. Box 625, Fyshwick, A.C.T.	32.76	"	"
Atkinson, Robert D., G.P.O. Box 958, Adelaide, S.A.	2000.00	Redemption	— 12.78
Baird, Charles S., 3 Inglis St, Sale	36.00	Dividend	— 2.79
Baird, John H., 28 Woolwich Rd, Hunters Hill, N.S.W.	496.92	"	— 8.78
Baker, Ian, 66 Chelmsford Ave, Epping, N.S.W.	12.00	"	"
Barlow, Clifford J., 19 Hatter St, Oakleigh	455.40	"	"
Barlow, Marjorie H. (Mrs), 22 Baldwin St, East Gordon, N.S.W.	18.00	"	— 2.79
Bell, Stephen A., P.O. Box 9514, Auckland, N.Z.	61.20	"	"
Bellshaw, John A., 121 Bassett Rd, Remuera, N.Z.	10.20	"	— 8.78
Bett, John H. (Dr) and Cleaver, Abigail G. J. (Mrs), Flat 20, 29 Upton Rd, Windsor	96.00	"	"
Berry, Paul R. (Dr), Acute Respir. Unit, Auckland Hospital, Auckland, N.Z.	22.04	"	"
Betty, Alan B., Mayfair Chambers, 48 The Terrace, Wellington, N.Z.	12.24	"	— 2.79
Billings, Michael B. (estate of), c/o Richard Billings and Assoc., 155 Poath Rd, Hughesdale	235.20	"	— 8.78
Blackburn, Thomas D., Unit 38, 144 Mill Point Rd, South Perth, W.A.	46.80	"	"
Blackman, Shona, 41 Seaciffe Rd, Onchunga, Auckland, N.Z.	15.30	"	"
Bridge, Kenneth A. (estate of), J. P. M. Wood Webster and Co., 17-19 Bridge St, Sydney, N.S.W.	700.00	Redemption	— 12.78
Bristow, John M., 68 Boundary Rd, Wahroonga, N.S.W.	72.00	Dividend	— 8.78
Brudenell-Bruce, Dana M. A. (Mrs), Trainers House, Moulton Paddocks, Newmarket, C887PJ, U.K.	61.20	"	"
Buckingham, Bridget A. (Mrs), 10 Hill St, Toorak	60.00	"	"
Buckingham, David A., 10 O'Shanassy St, Curtin, A.C.T.	30.00	"	"
Canning, George E., 11/16 Rowena Parade, Richmond	12.00	"	"
Caswell, Peter R., 90 Pembroke Rd, Coorparoo, Qld.	15.00	"	— 2.79
Catlow, Warren R. and Margot E. (Mrs), 32 Fuller St, Mitcham	12.00	"	"
Clemente, Robert J., 140 William St, Melbourne	100.00	Redemption	— 12.78
Coleman, Patrick L. and Suzanne M., 12 Ayocá St, Sth. Yarra	12.00	Dividend	— 8.78
Cooper, Harry, 56 Oxford St, Woollahra, N.S.W.	240.00	"	"
Cross, Geoffrey C. and Beighley Jane G. (Mrs), 342 Cascades Dve, Fairfax, California, U.S.A.	15.30	"	"
Cross, Stanley W. (estate of), c/o Gill Oxlade and Broad, 12 Castlereagh St, Sydney, N.S.W.	72.54	"	— 2.79
Cuthel, Glen W., 5 Rose St, Quirindi, N.S.W.	28.80	"	— 8.78
Darby, John J., 131 Armagh St, Christchurch, N.Z.	10.20	"	"
Davey, Pringle N., 5 Bucknell St, Christchurch 4, N.Z.	10.20	"	"
Davies, Margaret A. (Miss), c/o M. E. Jonston, 632 Station St, North Carlton	12.00	"	"
Day, Jane M. (Miss), Yanterilla, Oaky Creek Via Hall, A.C.T.	11.22	"	— 2.79
Day, Katherine (Miss), Yanterilla, Oaky Creek, Via Hall, A.C.T.	11.22	"	"
Day, Sarah E. (Miss), Yanterilla, Oaky Creek Via Hall, A.C.T.	11.22	"	"
Dixon, Peter, (Dr), 21 Berkeley St, Hawthorn	12.00	"	— 8.78
Dorabest Pty. Ltd., P.O. Box 878, North Sydney, N.S.W.	65.00	Interest	— 12.78
Downing, Margaret E. (Mrs) and Forrester, Nigel, c/o N. W. Forrester, 22 Gilles Rd, Woodley, S.A.	81.48	Dividend	— 8.78
Duke, Morag C. (Lady), c/o Grindleys Bank Ltd., 13 St James Sq, London, SW1Y, 4LF, U.K.	22.95	"	"
Dunn, Evelyn C. (Mrs), 213 Burwood Rd, Burwood, N.S.W.	99.90	"	— 2.79
Dunn, Gwenda G. (Mrs), Stonehaven, Via Geelong	10.56	"	— 8.78
Edgington, Mary P., 2 Malo Rd, Whale Beach, N.S.W.	12.00	"	"
Ellis, Edward C., 111 Clausen St, North Fitzroy	32.76	"	— 2.79
Endenburg, Robert G., 22 Hampton St, Hawthorn, S.A.	12.00	"	— 8.78
English, Jennifer (Mrs), 20 West Pde, Chatswood, N.S.W.	27.00	"	— 2.79
Evetts, Barry H., Outlook Rd, Mt Waverley	84.24	"	— 8.78
Farage, Salem A., 162 Fox Valley Rd, Wahroonga, N.S.W.	36.00	"	"
Farlow, Colin, 2 Cometrowe St, Drummoyno, N.S.W.	12.00	"	"
Farrell, Mary M. (Mrs), No. 5 R.D., Ashburton, Canterbury, N.Z.	10.20	"	— 2.79
Farrington, Edward P., 12 Jessie St, Preston	15.00	"	"
Field, Jean M. J. (Mrs), Woodfield, Cressy, Tas.	34.80	"	"
Floyd, Glenda (Mrs), P.O. Box 53, Benteleigh East	24.00	"	— 8.78
Foo, Puan Sri Rosalind Yu Ping, 18 Golf Club Rd, Ipoh, Perak, Malaysia	42.00	"	— 2.79
Foster, Eleanor L. (Mrs), 145 Arney Rd, Remuera, Auckland, N.Z.	25.50	"	— 8.78
Foster, John E., Flat 10, 4 Marei Rd, One Tree Hill, Auckland, N.Z.	16.32	"	"
Francis, Judith B. (Mrs), Tramella Baden-Powell Dve, Mt Eliza	69.60	"	"
Fry, William H., Lower Wonga, Via Woolooga, Qld.	65.28	"	"
Geddes, Pamela J. (Mrs), 12/192 Alma Rd, East St Kilda	14.40	"	"
Grapner, Fritz, Lot 19, Timothy Rd, Londonderry, N.S.W.	19.20	"	"
Gore, James R., P.O. Box 543, Hamilton, N.Z.	26.77	"	— 2.79
Gupta, Ram R., 16 Tagore Rd, Cantonment, Kanpur 208004, India	176.40	"	— 8.78
Gunning, Minnie C. (estate of), c/o Leigh M. Virtue, 291 George St, Sydney, N.S.W.	25.02	"	— 2.79

## Unclaimed Moneys Act 1962

Register of Unclaimed Moneys held by the—

Name of Owner on Books and Last Known Address.	Total Amount Due to Owner	Description of Unclaimed Money	Date when Amount first became Payable
\$			
AUSTRALIAN CONSOLIDATED INDUSTRIES LIMITED—continued.			
Harris, Stuart M., 8/39 Mascot Dve, Eastlakes, N.S.W.	19.20	Dividend	— 8.78
Heap, Andrew C., "Claremont", R.M.B. Box 419A, Armidale, N.S.W.	18.00	"	"
Heapy, George T., 49B Nassim Rd, Tanlin, Singapore 10	16.32	"	"
Hill, Barbara (Mrs), 332 Military Rd, Vaucluse, N.S.W.	24.00	"	"
Hill, William Springwood, Mount Rule Rd, Braddan, Isle of Man	201.60	"	"
Hinds, Phillipa A. (Mrs), 18/23 Lane Cove Rd, Ryde, N.S.W.	18.00	"	"
Holden, Josephine C. (Mrs), 17 Sackville St, Kew	15.84	"	"
Howden, Conrad G., 41 Light St, Bar Beach, N.S.W.	12.00	"	"
Hughes, Douglas W., 9 Tilshed Close, Druids Heath, Maypole, Birmingham, U.K.	48.96	"	"
Hunter-Patterson, Vane (Mrs), 8 Irving Rd, Toorak	145.26	"	— 2.79
Ingersoll, John K., c/o 46 Terrace Rd, Dulwich Hill, N.S.W.	24.00	"	— 8.78
Ings, Jack, 29/248 The Avenue, Parkville	12.00	"	— 2.79
Jackson, Peter A. and Driver, Robert F., c/o A. E. McIntosh and Henderson, 185 Elizabeth St, Sydney, N.S.W.	12.00	"	— 8.78
Jones, Barrie R., c/o Commercial Bank of Australia, 12 Old Jewry, London, EC.2, U.K.	60.18	"	"
Jonston, Clytie L. (Mrs), 15 Carroll St, Nth. Melbourne	12.00	"	"
Kelly, John W., Caramut North, Caramut	96.00	"	— 2.79
King, John H. B. (estate of), c/o Harold J. Goldberg, P.O. Box 158, Bondi Junction, N.S.W.	12.00	"	— 8.78
King, Myra E. (Mrs), Flat 12A Johanna Court, 48 Cromwell Rd, South Yarra	19.68	"	"
Lansell, Barbara (Mrs), "Chah Singh", Moulamein, N.S.W.	64.08	"	"
Larcombe, Denis E. (Mrs), 6/7 Morton St, Wollstonecraft, N.S.W.	12.00	"	"
Leslie, Heather M. (Mrs), 15 Scales Pde, Balgowlah, N.S.W.	30.00	"	— 2.79
Levy, Olive M. (Mrs), 89 Pacific Rd, Palm Beach, N.S.W.	75.00	"	"
Lyon, John, c/o The Manager, Nat. Westm. Bank Ltd., 117-Main St, Frodsham, Warrington, Lancashire, England	22.95	"	— 8.78
MacKay, Hector J., Barr Creek, Via Jandowae, Qld.	18.00	"	"
Markin, Alan Vasey, Concourse, East Ringwood	18.00	"	— 2.79
Martin, Andrew S., 35 John St, Eastwood, S.A.	101.25	Interest	— 12.79
Maskell, Harold J. M., Flat 5, 27 Billyard Ave, Elizabeth Bay, N.S.W.	96.00	Dividend	— 8.78
Matthews, Adeline T. (estate of), 67 Lennox St, Rockdale, N.S.W.	15.60	"	"
Maynes, Edwin G., 59 Cambridge St, Paddington, N.S.W.	14.04	"	"
Millward, Florence J., 15 Orchard St, Pymble, N.S.W.	14.40	"	"
Mitchell, Pamela A. (Mrs), Liddleton Station, Hartley, N.S.W.	18.00	"	— 2.79
Morrow, Millie A. (Mrs), Box 297 P.O. Haymarket, George St, Sydney	188.16	"	— 8.78
Murphy, Bert A., Flat 4, 10 Bay Rd, St Heliers, Auckland 5, N.Z.	58.76	"	"
McCann, Marion R. (Mrs), 22 Donald St, Highett	270.00	Interest	— 12.78
McClymont, William G. (estate of), c/o Sim McElrea, O'Donnell Borick and Thomas, P.O. Box 137, Dunedin, N.Z.	20.40	Dividend	— 8.78
McLean, John C., 16 Eastbourne Rd, Chiswick, London, W.4, U.K.	12.24	"	— 2.79
McCooke, Annabel H. (Miss), Flat 6, 58 Windsor Cres, Mont Albert	18.00	"	— 8.78
McGavin, Alison M. (Mrs), 11 Wells Rd, Beaumaris	18.00	"	"
National Trustees Exec. and Agency Co. of Australasia Ltd., 95 Queen St, Melbourne	1890.00	"	"
Nicholas, David R., 25 Burns Rd, Wahroonga, N.S.W.	18.00	"	— 2.79
Norton, Owen N., P.O. Box 187, Greymouth, N.Z.	10.20	"	— 8.78
Noyes, Geoffrey J., 27 Underwood Rd, Homebush, N.S.W.	24.00	"	"
O'Brien, Robert J. and Jill C. (Mrs), 6 Merlin St, Roseville, N.S.W.	57.60	"	"
O'Driscoll, Desmond, 28 Daymar Pl, Castle Cove, N.S.W.	36.00	"	"
Otto, Susan A. (Mrs), 11 Gibb St, North Ryde, N.S.W.	15.00	"	— 2.79
Palfreyman, John R., 54 Elizabeth St, Malvern	28.80	"	— 8.78
Parker, Gerald E. (estate of), c/o Bulbanna Administration Pty. Ltd., 411 Collins St, Melbourne	1593.90	"	"
Parsons, Rosamund (Mrs), Westcliff, c/o Marino P.O., S.A.	60.00	"	"
Pill, Leslie, 13 Picton St, Mascot, N.S.W.	28.80	"	"
Pitsch, Wendy A. (Mrs), 14 Sloane St, Paterson, N.S.W.	18.00	"	"
Poyner, Betty M., 53 Lovoni St, Cabramatta, N.S.W.	33.36	"	"
Raymond, Ada L. (Miss), 7 Arnold St, Killara, N.S.W.	192.60	"	— 2.79
Richmond, Dawn M. (Miss), 47 Ninth Ave, St Lucia, Qld.	12.00	"	"
Robinson, Eric, 29 Cluny Hill, Singapore 10	102.00	"	— 8.78
Robinson, Ingrid (Mrs), 23 Sherwood Ave, Te Atatu, Auckland, N.Z.	30.60	"	"
Robinson, Lennox W., 123 Sydney Rd, Fairlight, N.S.W.	37.92	"	"
Ross, Dorothy, 111 Forest Rd, Miranda, N.S.W.	19.20	"	"
Ryder, Stuart D., 1 Wakefield St, North Manly, N.S.W.	24.18	"	"
Saint, Harold F., 10 Wilkinson Ave, Somerton, S.A.	86.40	"	"
Scott Waive, John C., 67 Brentwood Ave, Warrawee, N.S.W.	10.80	"	— 2.79
Schulz, Karen L. (Miss), 45 Rose St, Mile End, S.A.	18.00	"	— 8.78
Sedgely, Audrey E. (Miss), c/o McGrath Blennerhassett, P.O. Box 757, Wellington, N.Z.	10.50	"	"
Shaw, Dorothy E. (Mrs), Gold Creek Rd, Brookfield, Qld.	43.20	"	"
Smith, Gregory W. and Neil R., 1/129 Burns Bay Rd, Lane Cove, N.S.W.	15.00	"	"
Smith, Vera L. (Mrs), Qld.	11.76	"	"
Snow, Grace L. (Miss), 15 Park Rd, Five Dock, N.S.W.	36.00	"	"

## Unclaimed Moneys Act 1962

## Register of Unclaimed Moneys held by the—

Name of Owner on Books and Last Known Address	Total Amount Due to Owner	Description of Unclaimed Money	Date when Amount first became Payable
\$			
<b>AUSTRALIAN CONSOLIDATED INDUSTRIES LIMITED—continued</b>			
South, William H., 8/3 Marion St, Killara, N.S.W.	24.00	Dividend	— 2.79
Stevens, Noeline M. (Mrs), Fairford Cave, N.Z.	33.00	"	— 8.78
Stuart, Christopher C., 30 Wright Ave, Swanbourne, W.A.	24.00	"	"
Swain, Ross B., 5 Harmony Rd, Huntington, N.Y. 11743, U.S.A.	16.32	"	"
Taylor, Gordon D., 14 McCrae Rd, Mt Wellington, N.Z.	10.20	"	"
Taylor, Valerie B. (Mrs), 2 Lakeview St, Boolaroo, N.S.W.	18.00	"	"
Thorneycroft, Robert, 62 Wilson St, North Carlton	12.00	"	"
Torrance, Clifford, 183 Muller Rd, Boondall Heights, Qld.	33.96	"	"
Tretter, Anna M., Hotel Elizabeth Park, Alt Aussee, Steermark, Austria	21.00	"	"
Turner, Marion L., Flat 2, 255 Sandgate Rd, Albion, Qld.	12.00	"	"
Vaughan, Terence J., 45 McKi M Mie St, Palmyra, W.A.	19.20	"	"
Waldie, Ian H., 32 Boundary St, Roseville, N.S.W.	39.00	"	"
Walter, Kenneth G., 4 Auvergne Ave, New Town, Tas.	11.64	"	"
Warburton, Mavis J. (estate of), c/o Gill Oxlade and Broad, 12 Castlereagh St, Sydney, N.S.W.	22.32	"	"
Waterhouse, Ashleigh G., c/o Gowrie Private Hotel, Northbourne Ave, Canberra City, A.C.T.	12.00	"	"
Watson, John R. and Kathleen S. (Mrs), 66 Monks Rd, Exter, Devon, U.K.	25.50	"	"
White, James F., 3/38 Kent Rd, Rose Bay, N.S.W.	18.00	"	"
Williamson, Anthony G. C., 29 Waru St, Khandallah, Wellington, N.Z.	25.50	"	— 2.79
Wilson, David L., Yarraman Station, Quirindi, N.S.W.	18.00	"	— 8.78
Wilson, Elodie J. K. (Mrs), P.O. Box 17015, Green Lane, Auckland, N.Z.	10.20	"	"
Wilson, Janceen M. (Mrs), P.M.B. 1015, Ebute, Metta, Lagos, Nigeria	13.44	"	"
Wilson, MacKenzie J., 6/43 Moruben Rd, Mosman, N.S.W.	90.00	"	"
Wiseley, Norman C., 86 Wiseley Rd, Hobsonville, Auckland, N.Z.	18.60	"	"
Wray, Judith, "Garrangill", Hartley, N.S.W.	33.00	"	— 2.79
Wrigley, Natalie B. (Mrs), c/o P.O. Upper Hutt, N.Z.	11.12	"	— 8.78
Young, Duncan M., Mansard House, First Ave, Frinton on Sea, Essex, U.K.	4252.50	"	"
Yuill, Colin K., 3 Karranga Ave, Killara, N.S.W.	48.00	"	"
Ryan, Kathleen A. (estate of), c/o Cutler Hughes and Harris, Box 3336 G.P.O., Sydney, N.S.W. 6029	200.00	Redemption	— 12.78
<b>A.C.I. CLOSURES</b>			
Ordovic, S., 1 Gloucester Crt, Seaholme 6030	32.80	Wages	14.1.79
<b>PRODUCTION EQUIPMENT LIMITED</b>			
Lindsay, David, 3 Macpherson St, Dandenong	22.40	Dividend	28.4.78
Plimmer, C. V., Box 106, Wellington, N.Z. 6211	86.63	"	"
<b>BRICK &amp; PIPE INDUSTRIES LIMITED</b>			
Barrett, Donald Lambert and Patterson, George Robert, Arranbank, Castleknoch, County Dublin, Ireland	10.08	Dividend	8.12.78
Baxter, Alan John, 669 Burke Rd, Camberwell	12.00	"	15.6.78
Bridges, Gregory, 10 Rose St, South Cronulla, N.S.W.	12.00	"	"
Brown, Francis Edmund, 2 Garde Crt, Dandenong	25.92	"	8.12.78
Carról, Frederick C. and Alma M. (Mrs), 1959 Nepean Hwy, Tootgarook	17.28	"	15.6.78
Donnelly, Thomas Cuthbert, 385 Sauchiehall St, Glasgow, Scotland C3, U.K.	71.61	"	"
Flámia, Joseph and Mary, Denise and Ginette, c/o Perpetual Trustee, P.O. Box 392, Canberra City, A.C.T.	10.08	"	"
Gilder, John Edward, 18 Phillip St, Springvale-North	36.00	"	"
Gill, Hilary Gresham (Mrs), 4 St Johns Park, Mount Town, Dunlaoghaire Co., Dublin, Eire	77.12	"	"
Hamilton, Everina Margaret, 1 Elland Ave, Box Hill	707.40	"	"
Harbig, Richard August P. W. and McLean, Donald Tasman, 663 Chapel St, South Yarra	64.13	Interest	29.12.78
Harrison, Frederick John (Dr), c/o Barclay Trust, P.O. Box No. 2, Golate House, Cardiff Cfirg, U.K.	66.03	"	30.6.78
Hewson, Phyllis May, 14 Bundoran Pde, Box Hill	21.38	"	"
Hockley, John, 16 Moffatt St, South Yarra	17.28	Dividend	15.6.78
Kerr, Robert B. and Marguerite Mae, 7 Alida Crt, Leopold	10.80	"	8.12.78
King, Ronald Richard, 29 Brook Close, Worthing, Sussex, England	10.20	"	15.6.78
McNamara, Joseph M., 24 Vautier St, Elwood	12.00	"	"
Messner, Leila Frances (Mrs), (address unknown)	51.84	"	"
Podbury, Murray Barton, 69 Aberdeen St, Newtown	187.92	"	"
Schofield, Thomas William (estate of), c/o John E. McDermott and Co., 9th Fl, 64 Castlereagh St, Sydney, N.S.W.	14.40	"	"
Surynt, Jerzy Leon, 16 Patricia Pl, Manurewa, Auckland, N.Z.	18.36	"	"
Taylor, Donald John (Dr), 57 Lincoln Dve, Shepparton	43.20	"	"
6212			



## Unclaimed Moneys Act 1962

## Register of Unclaimed Moneys held by the—

<i>Name of Owner on Books and Last Known Address</i>	<i>Total Amount Due to Owner</i>	<i>Description of Unclaimed Money</i>	<i>Date when Amount first became Payable</i>
<b>\$</b>			
<b>AMATIL LIMITED</b>			
Bethall, Richard, Pahau Pastures, Culverden, Canterbury, N.Z.	403.75	Dividend	2.3.78
MacFarlane, Alison R. L. (Mrs), Wadi Nimrin, Conway Flat, Hundalee, Nth. Canterbury, N.Z.	84.15	"	1.3.79
McGrath, Joan (Miss), 77 Alexander St, Greymouth, N.Z.	13.54	"	"
McLean, Margaret A. (Miss), c/o S. C. Burkitt, P.O. Box 765, Hastings, N.Z.	30.29	"	"
Passmore, Anthony R., 2 R.D. Albany, Auckland, N.Z.	197.00	"	2.3.78
Roberts, Francis H., P.O. Box 6074, Wellington, N.Z.	31.52	"	1.3.79
Shepherd, Herbert W. D., Ngahinapouri, R.D. 2 Ohaupo, Waikato, N.Z.	43.35	"	31.8.78
Ward, Rose P. M., (Mrs), 75 Cockle Bay Rd, Howick, Auckland, N.Z.	16.22	"	1.3.79
Wrigley, Natalie B. (Mrs), c/o P.O., Upper Hutt, N.Z.	168.50	"	2.3.78
Bright, Alexa M. (Miss), 28 Chalcot Cres, London NW1, England	71.67	"	"
Chan, Kim C., c/o Fraser and Co. (Pte), P.O. Box 789, Singapore	47.81	"	1.3.79
Dutriez, Paul E., 30 Rue D'Hauteville, 750 10 Paris, France	114.81	"	2.3.78
Grant, Roger B., No. 8 R.D., Te Puke, N.Z.	31.82	"	31.8.78
Hines, James W., 30 Greenland Rd, Remuera, Auckland, N.Z.	10.02	"	1.3.79
Lee, Sai Wah and Nancie (Mrs), 2205-6 Melbourne Plaza, 33 Queens Rd, Central Hong Kong	87.50	"	2.3.78
Rhodes, Ronald D., 6 Waiatarua Rd, Auckland 5, N.Z.	33.15	"	"
Charleton, Eileen (estate of), c/o Mr. Gerald S. Berrigan, 213 Park St, South Melbourne	34.96	"	31.8.78
Dakin, Robert S., 24 Stanton St, Doncaster	16.83	"	1.3.79
Eves, Christopher G., 6/60 Leopold St, South Yarra	32.00	"	2.3.78
Field, Jean M. (Mrs), Woodfield, Cressy, Tas.	58.50	"	1.3.79
Franklin, Patricia D. (Miss), 21 Cole St, Gardenvale	448.80	"	31.8.78
Frilay, Vincent G., 16 Bloomfield Rd, Ascot Vale	23.20	"	2.3.78
Harris, Margaret M. (Mrs), 42 Holmes Cres, Campbell, A.C.T.	78.00	"	2.3.78
Hayes, Claire E. (Mrs), Elliminook, Humphries Rd, Frankston	135.75	"	"
Henshaw, Gordon W., 579 Dean St, Albury, N.S.W.	50.00	"	"
Hill, Ivy P. (Mrs), 2-117 Ewos Pde, Cronulla, N.S.W.	12.60	"	1.3.79
Hitchins, Francis E., Cranbrook, W.A.	106.85	"	31.8.78
Horigan, Leslie J. (estate of), 19 Scarborough Grove, Beaumaris	37.50	"	2.3.78
Hughes, Helena M. (Miss), A3/1 Besebow St, Torrens, A.C.T.	34.00	"	"
Keroma Pty. Ltd., c/o Pledge Younger and Co., 200 East Tce, Adelaide, S.A.	850.00	"	31.8.78
Murray Bridge Hotel Pty. Ltd., 75 Grenfell St, Adelaide, S.A.	78.00	"	2.3.78
O'Brien, Mabel V. (Miss), 35 Russell St, Camberwell	10.80	"	1.3.79
Poutney, Richard K., P.O. Box 524, Newcastle, N.S.W.	25.60	"	2.3.78
Richards, Lee A. (Miss), 9/3 Seaview St, Fullarton, S.A.	20.00	"	"
Silverman, Joseph, 377 Kooyong Rd, Elsternwick	42.12	"	1.3.79
Sterling, Mirie E. (Mrs), 13-15 Zelandia Rd, Croydon	23.84	"	31.8.78
Suter, Charles K. (estate of), c/o 18 Head St, Elwood	31.25	"	2.3.78
Walter, Kenneth G., 4 Auvergne Ave, New Town, Tas.	232.05	"	1.3.79
Ween, Dorothy M. (Mrs), 230 Grange Rd, Flinders Park, S.A.	31.25	"	"
Wilson, Bruce J. S., Murdeduke, Winchelsea	30.00	"	31.8.78
Wilson, Julia (Mrs), 16 Kean St, Caulfield	36.96	"	2.3.78
Athans, Kimon R., 25 Headland Rd, Castle Cove, N.S.W.	18.00	"	1.3.79
Hunt, Annie M. (Mrs), 1-7 Violet St, Essendon	31.14	"	"
Bourke, Patricia M. (Mrs), 2/120 Chuter Ave, Ramsgate, N.S.W.	46.75	"	2.3.78
Bradley, Ian W., 17/234 Pacific Hwy, Lindfield, N.S.W.	68.00	"	31.8.78
Bristow, John M., 68 Boundary Rd, Wahroonga, N.S.W.	425.00	"	"
Browne, Maree G. (Mrs), 6 Dalmeny Rd, Northbridge, N.S.W.	45.00	"	1.3.79
Campbell, Renny M., 100 Jacob St, Bankstown, N.S.W.	16.00	"	31.8.78
Cantrall, John H., 205 Botany St, Randwick, N.S.W.	12.64	"	"
Cooper, Harry, 56 Oxford St., Woolahra, N.S.W.	648.00	"	"
Cull, Ernest A. (estate of), c/o Mr V. S. Gleeson, 8 Minna St, Burwood, N.S.W.	1109.25	"	2.3.78
Davies, Mabel (Mrs), 359 Oxley Rd, Sherwood, Qld.	35.00	"	"
Duncan, Constance I. A. (Mrs), c/o Mrs D'Arcy Reardon, Myalla, Warialda, N.S.W.	108.25	"	"
Franklin, Edwin R., 593 New South Head Rd, Rose Bay, N.S.W.	29.75	"	31.8.78
Furley, James R., 39 Goodope St, Paddington, N.S.W.	25.20	"	"
Garcia, Brian R. and Susan (Miss), 501 Marrickville Rd, Dulwich Hill, N.S.W.	75.00	"	2.3.78
Gillfeather, Aileen M., 34 Yungaburra Rd, Villawood, N.S.W.	16.16	"	"
Girling, Vera G. (estate of), c/o A.N.Z. Banking Group Ltd., 290 Pacific Hwy, Crows Nest, N.S.W.	92.00	"	31.8.78
Hall, Mary E. (estate of), c/o Dibbs Crowther and Osborne, 16 Barrack St, Sydney, N.S.W.	36.00	"	1.3.79
Hall, Valentine S., 64 Higginbotham St, Watson, A.C.T.	11.25	"	"
Hill, Raymond, c/o Bank of N.S.W., 341 George St, Sydney, N.S.W.	50.00	"	2.3.78
Horsley, Mary C. (Mrs) and Anne M. (Miss), "Yabtree", Tumbalong, N.S.W.	27.00	"	1.3.79
J. G. Mullaly Investments Pty. Ltd. (in Vol. Liq.), c/o Messrs Peat Marwick Mitchell and Co., P.O. Box H67, Australia Square, Sydney, N.S.W.	80.00	"	31.8.78
Larard, Janet (Mrs), Nornalup Rd, Denmark, W.A.	39.00	"	2.3.78
Levy, Olive M. (Mrs), 89 Pacific Rd, Palm Beach, N.S.W.	281.25	"	1.3.79
Maund, Owen S., 18 Ward St, Whyalla, S.A.	210.00	"	31.8.78
Muller, Kenneth F., 3/40 McKeon St, Maroubra, N.S.W.	21.25	"	"
Naughton, Claude B., P.O. Box 315, Surfers Paradise, Qld.	156.25	"	2.3.78

## Unclaimed Moneys Act 1962

## Register of Unclaimed Moneys held by the—

Name of Owner on Books and Last Known Address	Total Amount Due to Owner	Description of Unclaimed Money	Date when Amount first became Payable
\$			
AMATIL LIMITED—continued			
Rawson, Mabel (Miss), 149 Woodland St, Balgowlah, N.S.W.	10.00	Dividend	31.8.78
Russell, Joan A. (Miss), 1 New Illawarra Rd, Bexley North, N.S.W.	18.90	"	1.3.79
Short, Belinda J. (Miss), 33 Albert Pde, Ashfield, N.S.W.	24.00	"	31.8.78
Speight, Helen L. (Mrs), 20 Murray Rd, Beecroft, N.S.W.	125.00	"	2.3.78
Storaker, Neils and Neil, Edwin D. J., c/o National Bank of A'asia, 251 George St, Sydney, N.S.W.	72.00	"	1.3.79
Storey, Edwin W., 17/33 Kensington Rd, South Yarra	37.44	"	2.3.78
Taylor, Raymond T., 111 Prospect Rd, Summer Hill, N.S.W.	45.00	"	1.3.79
White, Charles E. and (Mrs.) Alma M., 15 Currawong Ave, Palm Beach, N.S.W.	38.25	"	31.8.78
Wilson, Donald, Rheuben Peter and Smith, Leonard 21 Bridge St, Rydalmere, N.S.W.	18.00	"	1.3.79
6026			
GENERAL MOTORS ACCEPTANCE CORPORATION, AUSTRALIA			
Wales, E. M. (estate of), 6 Robertson St, Toorak	65.00	Interest	23.4.78
Lewis, Judith A. (Mrs), 27 Burwood Cres, Remuera 5, Auckland, N.Z.	55.12	"	30.6.78
Hamberger, Jane, 39 Millswyn St, South Yarra	12.00	"	3.7.78
Burling, Louis C., 5 Tambu St, St Ives, N.S.W.	23.31	"	9.10.78
Watson, Geoffrey R., 35 Parr Ave, Curl Curl, N.S.W.	26.37	"	31.12.78
Button, Florence M. (Mrs), c/o A.N.Z. Bank Limited, 40 Elizabeth St, Hobart, Tas.	18.85	"	31.3.79
Lowder, Harold G., 196A Aberdeen St, Perth, W.A.	30.08	"	"
5999			
W.D. & H.O. WILLS (AUSTRALIA) LIMITED			
Edwards, Barry, 72 Kambrook Ave, North Caulfield	88.37	Holiday Pay	12.5.77
MacMillan, Lesley, 15 Butler St, Brighton	11.48	"	26.5.77
McCarthy, Dorothy, 77 Chesterfield Rd, Cheltenham	60.06	"	"
Pierak, June, 88A Coorrig Rd, Carnegie	91.82	"	14.6.77
Topcov, Rosie, 42 Emily St, Murrumbidgee	88.68	"	3.8.77
English, Michael, 3/52 Chelsea Rd, Chelsea	77.38	"	9.8.77
Windsor, Kelvin, 6 Parsons St, Mordialloc	44.21	"	12.8.77
Hamer, David, 26 Dummerill Rd, East Brighton	12.68	"	7.9.77
Fraser, Peter, 12/596 Neerim Rd, Hughsdale	31.60	"	15.9.77
Grant, Sharron, 5/6 Rosstown Rd, Carnegie	83.66	"	30.9.77
Trison, Robert, 43 Parkmore Rd, East Bentleigh	64.48	"	29.8.77
Gibson, Robert, 6/8 Marriot St, St Kilda	23.04	"	28.10.77
Healy, Shawn, 73 Waverley Rd, Caulfield	23.04	"	"
Duffy, Terrence, 3/16 Thackeray St, Elwood	114.42	"	22.11.77
Foggie, Peter, 33 Olive St, Hampton	76.37	"	8.3.78
Hill, Reginald, 30 Clive St, East Brighton	29.92	"	22.3.78
6027			
ARDMONA FRUIT PRODUCTS CO-OPERATIVE CO. LTD.			
Anderson, P., 17 Anderson St, Mooroopna	78.00	Wages	18.5.78
Davies, S., 47 Union Rd, Pennith, N.S.W.	52.00	"	"
Ceazy, D. J., Eichman Bli Bli Rd, Namboon	12.00	"	24.4.78
Bathman, J., P.O., Udera	25.00	"	22.3.78
Murrywether, K., 17 Bolmoral St, Shepparton	13.00	"	18.3.78
Rowe, D., Aluna C/Park, Kippa Ring, Redcliffes, Qld.	130.00	"	28.6.78
Smyth, D., P.O., Mooroopna	40.00	"	"
Walker, G., Box 70, Pleystowe, Qld.	21.00	"	14.2.79
6028			
LYSAGHT EMPLOYEES (VICTORIA) CREDIT UNION CO-OPERATIVE LIMITED			
Kruger, Richard John, 8 Tuckley St, Sorrento	15.57	Interest	31.3.78
Rogers, Rhoda Wendy, 28 Vale St, Mornington	10.00	Share Capital	21.2.78
Meyman, Roger Allen, 2/14 Carder Ave, Frankston	50.00	Savings	1.12.78
Williams, Rendell Neil, 19 Edward St, Hastings	10.00	Shares	10.11.78
Sun, Muammer, 5 Ellery St, Hastings	10.00	"	16.11.76
Koken, Fethi, 10/31-33 Burnt St, Nunawading	30.13	"	1.12.78
Harmer, Gary Leigh, 18 Fenfield St, Cranbourne	20.00	Savings	28.4.77
Burrows, Grant William, 53 McKirdys Rd, Somerville	59.11	"	31.3.78
Scown, Colin James (estate of), 9 Curlew Crt, Hastings	80.00	"	10.8.78
Javurek, Warrick Bernard, 5/21 Fairway St, Frankston	30.02	"	31.3.78
6156			
ARNOTT-BROCKHOFF-GUEST PTY. LIMITED			
Celep, S., 83/56 Derby St, Kensington	18.19	Wages	15.5.78
Ljubecic, L., 87 Elizabeth St, Richmond	73.72	"	8.6.78
Humphries, A., Flat 6, Gardner Ave, Mitcham	21.60	"	18.7.78
Hogan, D., 560 Camberwell Rd, Camberwell	11.09	"	8.12.78
6206			

## Unclaimed Moneys Act 1962

## Register of Unclaimed Moneys held by the—

Name of Owner on Books and Last Known Address	Total Amount Due to Owner	Description of Unclaimed Money	Date when Amount first became Payable
§			
<b>INDUSTRIAL EQUITY LIMITED</b>			
Todd, James S. and Cecil R., Nelsons Plains, via Raymond Terrace, N.S.W.	33.15	Dividend	11.11.77
Eagle, Cyril James, 26 Taradale Rd, Napier, N.Z.	23.84	"	"
Todd, George Hohepa (estate of), c/o Martin Evans Scott and Hurley, P.O. Box 5055, Wellington, N.Z.	37.28	"	"
Swans Ltd. Acq. C. E. Sellar, 151 Macquarie St, Sydney, N.S.W.	36.01	"	20.5.77
Whethan, Elizabeth, P.O. Box 573, Chatswood, N.S.W.	10.20	"	11.11.77
Williamson, Isabel M., Roanoke Flats, Francis St, Hyde Park, S.A.	10.20	"	"
Garrett, Doris I., 262 Marine Pde, New Brighton, Christchurch, N.Z.	37.53	"	20.5.77
Kwok, William, 32 Webb St, Wellington, N.Z.	54.67	"	"
Lanning, Hugh J. F., Settlement Rd, Swan Marsh	37.06	"	11.11.77
Swans Ltd. Acq. N. M. Thomson, 151 Macquarie St, Sydney, N.S.W.	10.46	"	"
Vincent, F. M. M., 43 Lewis St, Kalgoorlie, W.A.	38.79	"	12.11.76
Butcher, Laurence F. and Campbell, Ronald G., 77 Ladd St, Watsonia	27.37	"	20.5.77
Sears, Elizabeth Clare, 557 Argyle St, Moss Vale, N.S.W.	11.59	"	"
Barrivall, Hilton V., 27 Vivian Dr, Omohoroa, Tauranga Rd, N.Z.	10.62	"	"
Tso, Yu Jim, 9 Safari Cres, Johnsonville, Wellington 4, N.Z.	16.45	"	"
Cable, James I., 35 Hinemoa St, Kalgoorlie, W.A.	26.41	"	"
Dunning, Leslie F., 27 Spencer St, Bunbury, W.A.	10.71	"	11.11.77
Duxfield, Sidney R., P.O. Box 7, Merrylands, N.S.W.	40.81	"	20.5.77
Gardner, Gertrude E., 173 Dugan St, Kalgoorlie, W.A.	65.77	"	"
Griffith, A. R., c/o P.O. Box 293, Broken Hill, N.S.W.	42.73	"	"
De Hamvas, Cecely, 353 Church St, Melbourne	10.20	"	11.11.77
Jackson, Charles A., 34 Victoria Ave, Claremont, W.A.	55.21	"	20.5.77
Johnson, Alfred L., c/o Keogh O'Neill and Co., 179 St Georges Tce, Perth, W.A.	10.20	"	11.11.77
Parry, John, 107 Forest St, Kalgoorlie, W.A.	65.77	"	20.5.77
Saunders, Mary J., 11 Veda St, Hamilton, N.S.W.	10.97	"	11.11.77
Shorter, Harold Ashton, Ashton Stud, Rosewood, Qld.	44.16	"	20.5.77
Stanley, Caroline (estate of), 56 Albert St, Mt Lawley, W.A.	10.20	"	11.11.77
6155			
<b>RUSSELL, KENNEDY &amp; COOK</b>			
Greaves, D. M. (Mrs), 48 Lloyd St, Heidelberg West	138.65	Settlement	3.6.80
6202			
<b>NYLEX CORPORATION LIMITED</b>			
Allen, Waltraud (Miss), 24 George St, Hawthorn, S.A.	12.50	Dividend	5.5.78
Bell, Stephen A., Box 9514, Newmarket, Auckland, N.Z.	11.85	"	24.11.78
Blazey, Penelope J. (Mrs), 196 Cecil St, South Melbourne	17.15	"	5.5.78
Cook, Bernard G., 63 St Ina Rd, Heath, Cardiff, Wales, U.K.	18.23	"	"
Ellis, Rex, 57 Hocking Ave, Earlwood, N.S.W.	43.82	"	24.11.78
Empedocles, Stephen G. (estate of), c/o Dehn and Layderdale, 639 Station Rd, West Drayton, Middlesex, U.K.	15.43	"	5.5.78
Ferguson, Mary J. (Mrs), 1/62 Woorneck Rd, Carnegie	12.33	"	24.11.78
Jowell, Eric A. S. and Jowett, Humphrey A. C., Willawong, Yea	10.00	"	"
Kenny, Ellen F. (Mrs), 42 Wilberforce St, North Beach, W.A.	10.00	"	5.5.78
Leach, Duncan H., c/o H. K. and Shanghai Banking Corp., P.O. Box 3140, Church St, Station, New York, U.S.A.	12.75	"	"
MacMaster, Dorathea E. (Miss), 22 Union Rd, Surrey Hills	24.43	"	"
Main, Ruby L. (Mrs), 68 Kennedy St, Castlemaine	24.05	"	"
Morrow, Robert D. (Dr), Colombo Mansions, 867 Colombo St, Christchurch 1, N.Z.	17.00	"	"
Mustard, Aubrey R. C., P.O. Box 6309, Te Aro, Wellington, N.Z.	180.64	"	24.11.78
Norris, Mary N. (Mrs), 20 Walton St, Remuera, N.Z.	12.15	"	5.5.78
Peach, Ivor A., 76 Durham Rd, Surrey Hills	17.15	"	"
Powis, Joan C. (Mrs), 14 Harvie St, Glen Waverley	19.25	"	"
Rowley, Suzanne (Mrs), 10 Etham Ave, Darling Point, N.S.W.	53.90	"	24.11.78
Tattam, Stanley G., 2 Bindaree St, Greenslopes, Qld.	17.15	"	5.5.78
Von Behrens, Wieland E. (Dr), 6504 51st Ave, North East, Seattle, Washington 98115, U.S.A.	11.22	"	24.11.78
6205			
<b>AUSTRALIAN UNITED INVESTMENT COMPANY LIMITED</b>			
Marshall, Allan B. and Robert H. and Haagensen, Allan, 82 Beresford Rd, Rose Bay, N.S.W.	13.50	Dividend	23.3.78
6214			
<b>KIMPTON MINIFIE MCLENNAN LIMITED</b>			
Brown, R. W., Hotel Acton, Kendall St, Acton, A.C.T.	140.00	Dividend	31.3.77
6216			
<b>GENERAL CREDITS LIMITED</b>			
Hollander, Alvin S., P.O. Box 2434, Christchurch, N.Z.	59.85	Interest	30.4.78
6222			

## Unclaimed Moneys Act 1962

Register of Unclaimed Moneys held by the—

Name of Owner on Books and Last Known Address	Total Amount Due to Owner	Description of Unclaimed Money	Date when Amount first became Payable
S			
CRODA AUSTRALIA GROUP LTD.			
Barker, George, 8 Schebella Crt, Katoomba Rd, Beaumont, S.A.	90.00	Dissenting offeree	20.4.78
Cassidy, Maxwell, 51 Templeton St, Castlemaine	900.00	" "	"
Fairlie-Cunninghame, Georgina, "Hillside", Furracabad, N.S.W.	90.00	" "	"
Minnery, Olive, 166 Johnston St, Fitzroy	255.00	Dividend	—10.76
Murfit, Florence, 10 Learmont St, Ballarat 6223	252.00	Dissenting offeree	"
CAPEL COURT CORPORATION LIMITED			
Byrne, Margaret M. (Miss), 3/24 Parnell St, Elsternwick	58.80	Dividend	22.3.78
Harris, Bessie M. G. (Miss), c/o Kingsley and Michael Sutton, P.O. Box 162, Ballarat	28.80	"	21.9.78
Niall, Mary D. (estate of), c/o National Trustees, 95 Queen St, Melbourne 6334	14.40	"	"

## Companies Act 1961

POMERANZ HOLDINGS PTY. LTD.  
POMERANZ STOCKINETTE MANUFACTURING  
PTY. LTD.

LINOWOOL MILLS PTY. LTD.  
TEXERE PTY. LTD.  
ULTIMATE CONSTRUCTIONS PTY. LTD.  
KISLEVIND PTY. LTD.  
LOGAS KNITTING MILLS (SALES) PTY. LTD.  
DISPERSED PRODUCTS PTY. LTD.  
ARMOSS PTY. LTD.  
HARAPPA AGENCIES PTY. LTD.  
LOGAS KNITTING MILLS (INTERSTATE) PTY. LTD.  
ALMA PLASTICS PTY. LTD.  
(ALL IN VOLUNTARY LIQUIDATION)

Notice is hereby given that pursuant to section 272 of the Companies Act 1961, final meetings of the members of each of the abovenamed Companies will be held at 31 Talbot Avenue, Balaclava on Sunday, 29 June 1980 commencing at 8.30 a.m.

Business: To receive the Liquidator's Accounts.

Dated 19 May 1980

7239

C. BAKER, Liquidator

## Companies Act 1961, Section 254 (2) (b)

MOREGAY PTY. LTD.

Notice is hereby given that at an extraordinary general meeting of the members of the abovenamed Company held on 19 May 1980, it was resolved that the Company be wound up voluntarily and that Stephen Robert Thom, of 132 Union Road, Surrey Hills, be appointed liquidator.

Notice is also given that after 21 days from this date I shall proceed to distribute the assets. All creditors having any claims against the Company should furnish particulars of same by that date, otherwise I shall proceed to distribute the assets without regard to their claim.

STEPHEN R. THOM, 132 Union Road, Surrey Hills, 3127  
7241

## PEP SIGNS (RICHMOND) PTY. LTD.

NOTICE OF MEETING OF CREDITORS OR CONTRIBUTORIES

Notice is hereby given that a meeting of the contributories of Pep Signs (Richmond) Pty. Ltd. will be held at 443 Plenty Road Preston on 30 June 1980 at 2 o'clock in the afternoon to lay before the meeting an account of how the winding up has been conducted and of how the property of the Company has been disposed of.

Dated 21 May 1980

7248

Companies Act 1961—In the matter of DULAK STORES PTY. LTD.—Notice Re Meeting of Creditors, Pursuant to Section 260

Notice is hereby given that a Meeting of creditors of the abovenamed Company will be held at the Fitzgerald Room, Accountants House, 49 Exhibition Street, Melbourne, on Friday, 13 June 1980, at 11.00 a.m. the company having convened a meeting of its members for the same day for the purpose of considering a Resolution that the Company be wound up voluntarily.

Dated 20 May 1980

M. DULAK, Director

B. K. Taylor & Co., accountants, 576 St. Kilda Road,  
Melbourne, Vic. 3004 7247

## RIPON (No. 2) CO-OPERATIVE HOUSING SOCIETY LIMITED (IN LIQUIDATION)

SPECIAL RESOLUTION

Passed 20 May 1980

At a special meeting of the abovenamed Society duly convened and held at 144 Barkly Street, Ararat on 20 May 1980 at 8 p.m., the subjoined special resolution was duly passed:—

"That the Society having successfully completed its objectives be wound up voluntarily, and that Hugh James Carruthers of 144 Barkly Street, Ararat, be appointed liquidator for the purposes of the winding up."

7249

E. W. JAMES, Chairman of Meeting  
H. J. CARRUTHERS, Secretary

In the matter of the Co-operative Housing Societies Act 1958 and the Companies Act 1961; and in the matter of RIPON (No. 2) CO-OPERATIVE HOUSING SOCIETY LIMITED (in Liquidation)—Notice to Creditors

Notice is hereby given that all persons having any claim against the above Society are required on or before 30 June 1980 to send their names and addresses and particulars of their debts or claims to Hugh James Carruthers, the liquidator of the said Society at his office and if so required by notice in writing from the said liquidator are personally, or by their solicitors, to come in and prove their said debts or claims at such time or place as shall be specified in such notice; or, in default thereof, they shall be excluded from the benefit of any distribution made before such debts or claims are so lodged or proved.

Dated at Ararat, 21 May 1980

H. J. CARRUTHERS, Liquidator, 144 Barkly Street,  
Ararat 7250

**A. Z. CHAMOIS PTY. LTD. (IN LIQUIDATION)****MEMBERS FINAL MEETING**

Notice is hereby given that in terms of section 272 of the Companies Act 1961 as amended, a final general meeting of the Company will be held at the offices of the Liquidator, E. F. James, Public Accountant, 130 Mount Street, Heidelberg on Friday, 27 June 1980 at 10 a.m., for the purpose of having laid before it by the Liquidator, an account showing how the winding up has been conducted and the property of the Company disposed of.

Dated 23 May 1980

7251

E. F. JAMES, Liquidator

In the matter of J. & S. E. SUDUK NOMINEES PTY. LTD.—  
1979 Co. No. 11330

The Petition herein was presented on Friday, 16 May 1980 at 2.36 p.m.

Petitioner: Caddaye Augustine Proprietary Limited, the registered office of which is situate at 576 St. Kilda Road, Melbourne.

Petitioner's Solicitors: Messrs Arnold Bloch, Leibler & Co., 324 Little Lonsdale Street, Melbourne.

Any person who intends to appear at the hearing of this Petition must send notice of his intention to the Petitioner or its Solicitors not later than 4.00 o'clock in the afternoon of Wednesday, 25 June 1980.

7265

ARNOLD BLOCH, LEIBLER &amp; CO.

Companies Act 1961, Section 272 (2)

**SMITH & MOORE (ELECTRICAL) PTY. LTD. (IN LIQUIDATION)****NOTICE OF FINAL MEETING**

Notice is hereby given that pursuant to section 272 of the Companies Act 1961, a general meeting of members of Smith & Moore (Electrical) Pty. Ltd. will be held at the office of Brian W. Boase, 181 Bank Street, South Melbourne on Monday, 30 June 1980 at 10.00 a.m.

The purpose of the meeting is to lay accounts before it, showing the manner in which the winding up has been conducted and the property of the company disposed of, and of hearing any explanation that may be given by the liquidator.

Dated 28 May 1980

L. S. SMITH, Liquidator

Brian W. Boase, 181 Bank Street, South Melbourne,  
Vic. 3000 7266

Companies Act 1961

**GINI'S TRADING PTY. LTD. (IN VOLUNTARY LIQUIDATION)****NOTICE OF FINAL MEETING**

Notice is hereby given pursuant to section 272 (2) of the Companies Act 1961, that a General Meeting of Gini's Trading will be held on 30 June 1980 at 12 p.m. at the offices of Jamison, Cassidy & Co. 446 Collins Street, Melbourne for the purpose of receiving the liquidator's Account showing how the winding up has been conducted, and the property of the Company has been disposed of and of hearing any explanation thereof which the Liquidator may make.

Dated 22 May 1980

BARRY ROBERT JAMISON, Liquidator

Jamison, Cassidy & Co., 446 Collins Street, Melbourne,  
3000 7275

Companies Act 1961

**PAEC PTY. LTD. (trading as Elaines Nightclub and Restaurant)****NOTICE OF MEETING**

Notice is hereby given of a Meeting of Creditors of PAEC Pty. Ltd., to be held at the Australian Society of Accountants, Fitzgerald Room, 49 Exhibition Street, Melbourne, on Friday 6 June 1980 at 10.00 a.m. for the purpose of:

- (a) Nominating a person to be Liquidator of the Company.

**(b) Appointing a Committee of Inspection.**

A Creditor is not entitled to vote at the Meeting of Creditors unless they have lodged with the Chairman of the Meeting a Proof of the Debt which they claim to be due to them from the Company.

P. CHIN, Director

Proofs of Debt and Proxies should be sent to:—

E. P. TAYLOR, chartered accountant, 583 Hampton Street, Hampton, Vic. 3188. Phone 598 7077 7276

**INCENTIVE PREMIUMS PTY. LTD. (IN VOLUNTARY LIQUIDATION)****ADVERTISEMENT FOR FINAL MEETING**

At 11.00 a.m. on 11 July 1980 at the offices of Smith, Taggart & Co., 350 Hampton Street, Hampton, Victoria, a final meeting of shareholders will be held to receive and if thought fit to adopt the liquidator's final account and to resolve that the books and records be destroyed after the expiration of 3 months.

Dated 22 May 1980

7277

ANTHONY L. TAGGART, Liquidator

Companies Act 1961 (as Amended), Section 272 (1)

**IMMULA EQUITY PTY. LTD. (IN LIQUIDATION)****NOTICE OF MEETING OF CREDITORS**

Notice is hereby given that pursuant to Section 272 (1) of the Companies Act 1961 a meeting of creditors and contributories of the abovenamed company will be held at the office of Fordham, Williams & Co., Chartered Accountants, 521 Toorak Road, Toorak on 27 June 1980 at 10.00 a.m.

**Business**

1. To lay before the meeting an account of the Liquidators' acts and dealings and of the conduct of the winding up.

Dated 21 May 1980

And further take notice that, pursuant to Section 281 (4), We have lodged an account of our Receipts and Payments and Statements of the position in the winding up with the Commissioners for Corporate Affairs in respect of the two year period ended 8 March 1980, and that the statements are available at this office for inspection by any creditor or person interested, between the hours of 9.00 a.m. and 5.15 p.m. on any business day.

B. E. FORDHAM AND A. J. HOWELL, Liquidators

Fordham, Williams & Co., chartered accountants, 521 Toorak Road, Toorak, Vic. 3142. Telephone: 24 7511

7278

Companies Act 1961—In the matter of SHILTON HOLDINGS Pty. Ltd. (in Voluntary Liquidation)—Notice Convening Final Meeting of Members, Pursuant to Section 272

Notice is hereby given pursuant to Section 272 of the Companies Act 1961 that a General Meeting of Members of the abovenamed Company will be held at the Offices of B. K. Taylor & Co., 3rd Floor, Dairy Industry House, 576 St. Kilda Road, Melbourne, on Thursday 10 July 1980, at 11.00 a.m. for the purpose of having an account laid before it showing the manner in which the winding up has been conducted and the property of the company disposed of and of hearing any explanations that may be given by the Liquidator.

Dated 22 May 1980

B. K. TAYLOR, Liquidator

B. K. Taylor & Co., accountants, 576 St. Kilda Road, Melbourne, Vic. 3004 7279

Companies Act 1961—In the matter of MURFDOR PROPRIETARY LIMITED (in Voluntary Liquidation)—Notice Convening Final Meeting of Members, Pursuant to Section 272

Notice is hereby given pursuant to Section 272 of the Companies Act 1961 that a General Meeting of Members of the abovenamed Company will be held at the Offices of B. K. Taylor & Co., 3rd Floor, Dairy Industry House, 576 St. Kilda Road, Melbourne, on Thursday 10 July 1980, at 9.30 a.m. for the purpose of having an account laid before

it showing the manner in which the winding up has been conducted and the property of the company disposed of and of hearing any explanations that may be given by the Liquidator.

Dated 22 May 1980

B. K. TAYLOR, Liquidator

B. K. Taylor & Co., accountants, 576 St. Kilda Road,  
Melbourne, Vic. 3004 7280

Section 140

IAN NEIL NELSON

NOTICE OF INTENTION TO DECLARE DIVIDEND

Notice is hereby given that a second dividend is to be declared on 30 May 1980.

Creditors who have not yet proved their debt are now advised to do so prior to 30 May 1980 or be excluded from the dividend.

E. P. TAYLOR, Trustee, 583 Hampton Street, Hampton,  
3188. Telephone 598 7077 7281

*Companies Act 1961*—In the matter of YAMA KINA PTY. LTD. (in Liquidation), formerly trading as "Slumber House"

Notice is hereby given that at an extraordinary meeting of the members of the abovenamed Company held on 22 May 1980, it was resolved that the Company be wound up voluntarily and at a meeting of creditors held on the same day pursuant to section 260 it was resolved that for such purpose Mr. D. J. Cogle of 144 Jolimont Road, East Melbourne, Public Accountant, be appointed Liquidator.

Notice is also given that after twenty-one days from this date I shall proceed to distribute the assets. All creditors having any claim against the Company should furnish particulars of same by that date, otherwise I shall proceed to distribute the assets without regard to their claim.

Dated 22 May 1980

D. J. COUGLE, Liquidator

Bent & Cogle, public accountants, 144 Jolimont Road,  
East Melbourne 7282

*Companies Act 1961*—In the matter of FORTY WINKS PTY. LTD. (in Liquidation)

Notice is hereby given that at an extraordinary meeting of the members of the abovenamed Company held on 22 May 1980, it was resolved that the Company be wound up voluntarily and at a meeting of creditors held on the same day pursuant to section 260 it was resolved that for such purpose Mr. D. J. Cogle of 144 Jolimont Road, East Melbourne, Public Accountant, be appointed Liquidator.

Notice is also given that after twenty-one days from this date I shall proceed to distribute the assets. All creditors having any claim against the Company should furnish particulars of same by that date, otherwise I shall proceed to distribute the assets without regard to their claim.

Dated 22 May 1980

D. J. COUGLE, Liquidator

Bent & Cogle, public accountants, 144 Jolimont Road,  
East Melbourne 7283

*Companies Act 1961*—In the matter of KINFILIN PTY. LTD. (in Liquidation)

The above Company went into voluntary liquidation on 22 May 1980, and I was appointed Liquidator.

Dated 22 May 1980

D. J. COUGLE, Liquidator

Bent & Cogle, public accountants, 144 Jolimont Road,  
East Melbourne 7284

*Companies Act 1961*—In the matter of KINSTROM PROPERTIES PTY. LTD. (in Liquidation)

The above Company went into voluntary liquidation on 22 May 1980, and I was appointed Liquidator.

Dated 22 May 1980

D. J. COUGLE, Liquidator

Bent & Cogle, public accountants, 144 Jolimont Road,  
East Melbourne 7285

*Companies Act 1961*—In the matter of FORTY WINKS (SOUTH MELBOURNE) PTY. LTD. (in Liquidation)

The above Company went into voluntary liquidation on 22 May 1980 and I was appointed Liquidator.

Dated 22 May 1980.

D. J. COUGLE, Liquidator

Bent & Cogle, public accountants, 144 Jolimont Road,  
East Melbourne 7286

*Companies Act 1961*—In the matter of KINSTROM INVESTMENTS PTY. LTD. (in Liquidation)

The above Company went into voluntary liquidation on 22 May 1980 and I was appointed Liquidator.

Dated 22 May 1980.

D. J. COUGLE, Liquidator

Bent & Cogle, public accountants, 144 Jolimont Road,  
East Melbourne 7287

*Companies Act 1961*, Section 254 (2) (b)

VALCALYPSO PTY. LTD.

MEMBERS' VOLUNTARY WINDING UP

Notice is hereby given that at an Extraordinary General Meeting of the Members of Valcalypso Pty. Limited held on 22 May 1980, it was resolved that the Company be wound up voluntarily and that Philip Douglas George, Chartered Accountant of 500 Bourke Street, Melbourne be appointed liquidator.

Notice is also given that 21 days from this date I shall proceed to distribute the assets. All creditors having any claims against the Company should furnish particulars of same by that date, otherwise I shall proceed to distribute the assets without regard to their claim.

Dated 22 May 1980

P. D. GEORGE, Liquidator

Arthur Young & Company, 500 Bourke Street, Melbourne,  
Vic. 3000 7290

The *Companies Act 1961*

RE: SLIM RUBBER NAILRON PTY. LTD. (IN LIQUIDATION)

Notice is hereby given that at an Extraordinary Meeting of the Members of the abovementioned Company held on 22 May 1980, it was resolved that the Company be wound up voluntarily and that Desmond Peter Deckker be appointed Liquidator.

Notice is also given that after twenty-one days from this date, I shall proceed to distribute the assets of the Company. All creditors who have any claim against the Company should furnish particulars of same by that date, otherwise I shall proceed to distribute the assets without regard to their claim.

Dated 23 May 1980

D. P. DECKKER, Liquidator

O'Keeffe & Deckker, accountants, 66 High Street, Glen  
Iris, 3146 7298

*Companies Act 1961*—In the matter of GLENGARI VANITY CABINETS PTY. LTD. (in Liquidation)

Notice is hereby given that at a meeting of shareholders of Glengari Vanity Cabinets Pty. Ltd. of 38 King Street, Airport West held on 22 May 1980 the following resolution was passed as a Special Resolution:

"That the Company be wound up voluntarily and that Mr. Scott Maurice Nunan of Curtain & Nunan, Chartered Accountants, 486 Sydney Road, Coburg be appointed Liquidator."

7299

S. M. NUNAN, Liquidator

BEACHSIDE ACCOMMODATION PTY. LIMITED (IN VOLUNTARY LIQUIDATION)

NOTICE OF FINAL MEETING

Notice is hereby given that pursuant to Section 272 of the *Companies Act 1961* the final meeting of the members of the Company will be held at the office of Siree, Nixon, Watt & Co., 257 Collins Street, Melbourne on Monday 30 June 1980, at 9.45 a.m. for the purpose of having an

account laid before them showing the manner in which the winding up had been conducted and hearing any explanations that may be given by the liquidator.

Dated 23 May 1980

N. W. CURWOOD, Liquidator  
Sicree, Nixon, Watt & Co., 257 Collins Street, Melbourne  
7300

I. W. RICE & COMPANY PTY. LIMITED

FINAL MEETING OF MEMBERS

Notice is hereby given, in pursuance to Section 272 of the *Companies Act 1961*, that a General Meeting of the members of the abovenamed Company will be held at 35th Floor 50 Bridge Street, Sydney on Friday, 27 June 1980, at 10.00 o'clock in the forenoon, for the purpose of having the liquidator's account laid before them showing the manner in which the winding up has been conducted and the property of the company disposed of and of hearing any explanation that may be given by the liquidator; and also of determining by resolution the manner in which the books, accounts and documents of the Company and of the liquidator thereof shall be disposed of.

Dated 16 May 1980

7301

N. F. STEVENS, Liquidator

*Companies Act 1961*, Section 254 (2) (b)

ALAN BISHOP IMPORTS PTY. LTD. (As Trustee of Alan Bishop Imports Unit Trust trading as Wholesalers and Importers at 605 Burwood Road Hawthorn)

Notice is hereby given that at an Extraordinary General Meeting of the Members of the abovenamed Company held on 21 May 1980, it was resolved that the Company be wound up voluntarily and that Messrs Michael Ashley Coppins and John Barry Hutchins of Pannell Kerr Forster, 271 William Street, Melbourne be appointed joint and several Liquidators and at a meeting of creditors held later on the same day, the appointment of Messrs Michael Ashley Coppins and John Barry Hutchins as Liquidators was confirmed.

Notice is also given that after 21 days from this date, we shall proceed to distribute the assets. All creditors having any claims against the company should furnish particulars of same by that date, otherwise we shall proceed to distribute the assets without regard to their claim.

Dated 21 May 1980

M. A. COPPINS AND J. B. HUTCHINS, Joint and Several Liquidators

Messrs Pannell Kerr Forster, 271 William Street, Melbourne 3000  
7302

In the matter of the *Companies Act 1961*; and in the matter of BEELAWONG PROPRIETARY LIMITED (in Liquidation)

Notice is hereby given in accordance with Section 254 (2) of the *Companies Act 1961* that at an extraordinary general meeting of the abovenamed company, duly convened and held at 520 Swift Street, Albury, New South Wales on 22 May 1980 the following special and ordinary resolutions were passed respectively.

"That the company be wound up voluntarily"; and

"That Mr Robert Henry Salisbury of 520 Swift Street, Albury, New South Wales, be and is hereby appointed liquidator of the company."

Dated 22 May 1980

7305

E. H. BAWDEN, Director

The *Companies Act 1961*—In the matter of AUCTION CARAVANS (DANDENONG) PTY. LTD. (in Liquidation)

Notice is hereby given that at an Extraordinary Meeting of Members of the abovenamed Company held on Wednesday 9 April 1980 it was resolved that the Company be wound up voluntarily and at a Meeting of Creditors held on Wednesday 9 April 1980 it was resolved that for such purpose Anthony George Hodgson of Messrs Ferrier Hodgson Green & Co. Chartered Accountants, be appointed Liquidator.

Notice is also given that after twenty-one (21) days from this date I shall proceed to distribute the assets. All Creditors having any claim against the Company should furnish particulars of same by that date, otherwise I shall proceed to distribute the assets without regard to their claim.

Dated 26 May 1980

A. G. HODGSON, Liquidator  
Ferrier Hodgson Green & Co., chartered accountants, 459 Collins Street, Melbourne 3000  
7303

The *Companies Act 1961*

DEBONAIR MENSWEAR & JEANERY PTY. LTD. (IN LIQUIDATION)

NOTICE CONVENING FINAL MEETING OF MEMBERS AND CREDITORS, PURSUANT TO SECTION 272

Notice is hereby given pursuant to Section 272 of the *Companies Act 1961* that a General Meeting of the members and Creditors of the abovenamed Company will be held at the offices of Messrs Ferrier Hodgson Green & Co., Chartered Accountants, 24th floor, 459 Collins Street, Melbourne, on 30 June 1980, at 10.00 o'clock in the forenoon and for the purpose of having an account laid before them showing the manner in which the winding up has been conducted and the property of the Company disposed of and of hearing any explanations that may be given by the Liquidator.

Dated 19 May 1980

MESSRS FERRIER HODGSON GREEN & CO., chartered accountants, 24th Floor, 459 Collins Street, Melbourne, 3000  
7304

*Companies Act 1961*, Section 254

J. S. McCLELLAND PTY. LTD.

At an extraordinary general meeting of the members of the above-named company, duly convened and held at 11.15 a.m. at floor 8, 128 Exhibition Street, Melbourne on 23 May 1980, the following resolution was passed as a special resolution:

"That the company be wound up voluntarily and that Mr A. D. Cran, Chartered Accountant, be and is now appointed liquidator of the company and that he be authorised to destroy the books and records of the company after dissolution of the company."

Notice is hereby given that after twenty-one days from this date I shall proceed to distribute the assets. All creditors having any claims against the company should furnish particulars of same by that date, otherwise I shall proceed to distribute the assets without regard to their claim.

Dated at Melbourne, 23 May 1980

7306

A. D. CRAN, Liquidator

In the Supreme Court of Victoria—In the matter of the *Companies Act 1961*; and in the matter of B.S.F. FREIGHT (MANAGEMENT) PTY. LTD.—Advertisement of Petition

Notice is hereby given that a Petition for the winding-up of B.S.F. Freight (Management) Pty. Ltd. by the Supreme Court was on 12 May 1980 presented by Brambles Holdings Ltd. and that the said Petition is directed to be heard before the Court sitting at the Law Courts William Street Melbourne on 19 June 1980 at the hour of 10.30 o'clock in the forenoon; and any creditor or contributory of the said Company desiring to support or oppose the making of an Order on the said Petition may appear at the time of hearing by himself on his Counsel for that purpose; and a copy of the Petition will be furnished to any creditor or contributory of the said Company requiring the same by the undersigned on payment of the regulated charge for the same.

The Petitioner's address is: B.H.P. House, 140 William Street, Melbourne.

The Petitioner's solicitors are: Messrs Paveys, of 390 Lonsdale Street, Melbourne.

PAVEYS, Solicitors for the Petitioner

NOTE—Any person who intends to appear on the hearing of the said Petition must serve on or send by post to the abovenamed Solicitors, notice in writing of his intention so

to do. The notice must state the name and address of the person, or, if a firm, the name and address of the firm and must be signed by the person or firm, or his or their Solicitor (if any) and must be served, or if posted, must be sent by post in sufficient time to reach the abovenamed not later than 4 o'clock in the afternoon of 18 June 1980.

7307

## Companies Act 1961

J. L. WARREN PTY. LTD. (IN LIQUIDATION)

## NOTICE OF INTENTION TO DECLARE DIVIDEND

Take notice that as Liquidator of the abovenamed Company, I intend to declare a dividend in this matter.

I hereby set Tuesday, 10 June 1980 as the last day on which creditors may lodge proofs of debt. Any creditor who has not lodged a proof of debt by that date shall be excluded from the dividend and I shall proceed to distribute the dividend without regard to any debt that has not been proved.

Dated 19 May 1980

7308 MICHAEL W. E. HOSKING, Liquidator

The Companies Act 1961, Section 254 (2) (b)

MARFRANK PTY. LTD. (IN MEMBERS VOLUNTARY LIQUIDATION)

Notice is hereby given that at an Extraordinary General Meeting of Members of the abovenamed Company held on 23 May 1980 it was resolved that the Company be wound up voluntarily and that Geoffrey Ormond Harrison of 12th Floor, 440 Collins Street, Melbourne be appointed Liquidator.

Notice is also given that after 21 days from this date, I shall proceed to distribute the assets. All creditors having any claims against the Company should furnish particulars of their claims by that date, otherwise I shall proceed to distribute the assets without regard to their claims.

Dated 23 May 1980

G. O. HARRISON, Liquidator

Touche Ross &amp; Co., chartered accountants, 440 Collins Street, Melbourne 3000 7309

## The Companies Act 1961

MARFRANK PTY. LTD. (IN LIQUIDATION)

## NOTICE CONVENING FINAL MEETING OF THE COMPANY PURSUANT TO SECTION 272 (1)

Notice is hereby given that the Final Meeting of Members of the abovenamed Company will be held at the offices of Touche Ross and Co., 12th Floor, 440 Collins Street, Melbourne on 1 July 1980 at 10.00 a.m. for the purpose of laying before the Meeting an account showing how the winding up has been conducted and the property of the Company has been disposed of and giving any explanation thereof.

Dated 27 May 1980

G. O. HARRISON, Liquidator

Touche Ross &amp; Co., chartered accountants, 440 Collins Street, Melbourne 3000 7310

Companies Act 1961—In the matter of FABWELD PTY. LTD. —Notice of Meeting of Creditors, Pursuant to Section 260

Notice is hereby given that a meeting of Creditors of the abovementioned Company will be held at 177 Eley Road Blackburn South on Friday, 20 June 1980 at 2.30 p.m.

The Company having convened an extraordinary general meeting of the members for the same day for the purpose of considering a special resolution that the Company be wound up voluntarily.

Dated 21 May 1980

R. SHAW, Director

Clive Morris &amp; Staff, public accountants, 177 Eley Road, Blackburn South, 3130. Telephone 232 3027 7311

## Companies Act 1961

EXECUTIVE (E.A.M.) PTY. LTD.

## NOTICE OF RESOLUTION

Notice is hereby given that at an extraordinary general meeting of members of the abovenamed company held on 23 May 1980 it was resolved that the company be wound up voluntarily and that Messrs David John Olifent and Leonard Noel Anderson, Chartered Accountants, of 447 Collins Street, Melbourne be appointed to act jointly and severally as liquidators for the purpose of such winding up.

Dated 23 May 1980

DAVID JOHN OLIFENT, Liquidator

LEONARD NOEL ANDERSON, Liquidator

Price Waterhouse &amp; Co., 447 Collins Street, Melbourne, 3000 7312

## Companies Act 1961

EXECUTIVE AVIONICS PTY. LTD.

## NOTICE OF RESOLUTION

Notice is hereby given that at an extraordinary general meeting of members of the abovenamed company held on 23 May 1980 it was resolved that the company be wound up voluntarily and that Messrs David John Olifent and Leonard Noel Anderson, Chartered Accountants, of 447 Collins Street, Melbourne be appointed to act jointly and severally as liquidators for the purpose of such winding up.

Dated 23 May 1980

DAVID JOHN OLIFENT, Liquidator

LEONARD NOEL ANDERSON, Liquidator

Price Waterhouse &amp; Co., 447 Collins Street, Melbourne, 3000 7313

## Companies Act 1961

EXECUTIVE (E.A.L.) PTY. LTD.

## NOTICE OF RESOLUTION

Notice is hereby given that at an extraordinary general meeting of members of the abovenamed company held on 23 May 1980 it was resolved that the company be wound up voluntarily and that Messrs David John Olifent and Leonard Noel Anderson, Chartered Accountants, of 447 Collins Street, Melbourne be appointed to act jointly and severally as liquidators for the purpose of such winding up.

Dated 23 May 1980

DAVID JOHN OLIFENT, Liquidator

LEONARD NOEL ANDERSON, Liquidator

Price Waterhouse &amp; Co., 447 Collins Street, Melbourne, 3000 7314

In the matter of the Companies Act 1961; and in the matters of TOOLEQ PTY. LTD. (in Liquidation)—Notice of Final Meeting of Members, Pursuant to Section 272

Notice is hereby given in pursuance of section 272 of the Companies Act 1961 that a General Meeting of the members of the Company will be held at the office of Messrs Coopers & Lybrand, 18th Floor, 461 Bourke Street, Melbourne on 30 June 1980 at 10 o'clock in the forenoon for the purpose of having accounts laid before it showing the manner in which the winding up has been conducted and the property of the company disposed of, and hearing any explanation that may be given by the liquidators.

Dated 28 May 1980

J. M. WALSH, Liquidator

A. M. HORSBURGH, Liquidator

J. M. Walsh and A. M. Horsburgh, chartered accountants, 499 St. Kilda Road, Melbourne, Vic. 3000 7315

In the matter of the Companies Act 1961; and in the matter of SREWARD PTY. LTD. (in Liquidation)—Notice of Final Meeting of Members, Pursuant to Section 272

Notice is hereby given in pursuance of section 272 of the Companies Act 1961 that a General Meeting of the members of the Company will be held at the office of Messrs Coopers & Lybrand, 18th Floor, 461 Bourke Street, Melbourne on 30 June 1980 at 10 o'clock in the forenoon



for the purpose of having accounts laid before it showing the manner in which the winding up has been conducted and the property of the company disposed of, and hearing any explanation that may be given by the liquidator.

Dated 28 May 1980

R. F. HUGHES, Liquidator

Robert Foster Hughes, chartered accountant, 17th Floor,  
461 Bourke Street, Melbourne, Vic. 3000 7316

*Companies Act 1961*

KINGSLEY HUNTER CONTRACTORS PTY. LTD. (IN LIQUIDATION)

NOTICE OF FINAL MEETING OF MEMBERS, PURSUANT TO SECTION 272

Notice is hereby given that the final meeting of the members of the above-named company will be held at Deloitte Haskins & Sells, 11th Floor, 461 Bourke Street, Melbourne, 3000 on 30 June 1980 at 10.00 a.m. for the purpose of laying before the meeting an account showing how the winding up has been conducted and the property of the company disposed of and hearing any explanation that may be given by the liquidator.

Dated 22 May 1980

7317

A. S. FURZE, Liquidator

*Companies Act 1961*

OCRAM PTY. LIMITED

NOTICE OF RESOLUTION

Notice is hereby given that at an extraordinary general meeting of members of the abovenamed company held on 19 May 1980, it was resolved that the company be wound up voluntarily and that Mr John Edwin Tomlinson chartered accountant, of 447 Collins Street, Melbourne, be appointed as liquidator for the purpose of such winding up.

Dated 21 May 1980

JOHN EDWIN TOMLINSON, Liquidator

Price Waterhouse & Co., 447 Collins Street, Melbourne  
3000 7318

*Companies Act 1961*

GENERAL MANAGEMENT HOLDINGS LTD.

NOTICE OF RESOLUTION

Notice is hereby given that at an extraordinary general meeting of members of the abovenamed company held on 19 May 1980 it was resolved that the company be wound up voluntarily and that Messrs David John Olifent and Leonard Noel Anderson, Chartered Accountants, of 447 Collins Street, Melbourne be appointed to act jointly and severally as liquidators for the purpose of such winding up.

Dated 20 May 1980

D. J. OLIFENT, Liquidator

L. N. ANDERSON, Liquidator

Price Waterhouse & Co., 447 Collins Street, Melbourne  
3000 7319

In the matter of the *Companies Act 1961*; and in the matter of GLOBAL MARINE AUSTRALASIA PTY. LTD. (in Liquidation)—Notice of Final Meeting of Members Pursuant to Section 272

Notice is hereby given in pursuance of section 272 of the *Companies Act 1961* that a General Meeting of the members of the above company will be held at the office of Messrs Coopers and Lybrand, 461 Bourke Street, Melbourne on 2 July 1980, at 9.30 o'clock in the forenoon for the purpose of having an account laid before it showing the manner in which the winding up has been conducted and the property of the company disposed of, and hearing any explanation that may be given by the liquidator.

Dated 14 May 1980

J. L. MAFFEY, Liquidator

J. L. Maffey, chartered accountant, 15th Floor, 461 Bourke  
Street, Melbourne, Vic. 3000 7320

No. 38—21570/80—6

The *Companies Act 1961*—In the matter of CHECKPOINT TYRE SERVICE PTY. LTD. (in Liquidation)

Notice is hereby given that at an extraordinary General Meeting of the members of the abovenamed Company held on 14 May 1980, it was resolved that the Company be wound up voluntarily and that Michael William Ernest Hosking be nominated as Liquidator for the purposes of such winding up, and that at a meeting of Creditors held later on the same day, my appointment as Liquidator was confirmed.

Notice is also given that persons having claims against the Company should lodge a proof of debt within 21 days at my office at 1st Floor, 153 Park Street, South Melbourne 3205.

Dated 14 May 1980

MICHAEL W. E. HOSKING, Liquidator

Hosking, Dyer and Co., public accountants, 1st Floor, 153  
Park Street, South Melbourne 3205. Telephone 690 6466

7321

In the Supreme Court of Victoria—Co. 11285—In the matter of the *Companies Act 1961*; and in the matter of PETCHEM (GIPPSLAND) PTY. LTD.—Notice of Winding Up Order

Winding Up Order made 15 May 1980.

Name and address of Liquidator: Robert Arthur Waters,  
460 Bourke Street, Melbourne.

B. J. O'DONOVAN, Crown Solicitor for the Common-  
wealth and Solicitor for the Petitioner 7323

*Companies Act 1961*

J. V. ANGLISS (HOLDINGS) PTY. LTD. (IN VOLUNTARY LIQUIDATION)

Notice is hereby given that, pursuant to section 272 of the *Companies Act 1961*, the final meeting of the members of the Company will be held at 11th Floor, 500 Collins Street, Melbourne on 23 June 1980 at 10.00 a.m. for the purpose of laying before the meeting the accounts of the winding up and any explanation thereof.

Dated 20 May 1980

ALAN J. MANGAN, liquidator, 11th Floor, 500 Collins  
Street, Melbourne 7345

*Companies Act 1961*

Notice is hereby given that pursuant to section 272 of the *Companies Act* a Final Meeting of the creditors of the undermentioned companies will be held at the offices of Bent & Cogle, Public Accountants, 144 Jolimont Road, East Melbourne, at the time stated on 30 June 1980.

BUSINESS TO RECEIVE THE LIQUIDATOR'S ACCOUNTS

9.15 a.m. JONSTEVE PTY. LTD. (IN LIQUIDATION)

9.30 a.m. EVENGELOS PTY. LTD. (IN LIQUIDATION)

9.45 a.m. CAMPUS FASHIONS PTY. LTD. (IN LIQUIDATION)

10.00 a.m. J. & P. J. MEATS PTY. LTD. (IN LIQUIDATION)

10.15 a.m. ALLARD & COLLINGS PTY. LTD. (IN LIQUIDATION)

10.30 a.m. LAKO PTY. LTD. (IN LIQUIDATION)

10.45 a.m. ADOKS HOLDINGS PTY. LTD. (IN LIQUIDATION)

11.00 a.m. WILSHEP INVESTMENTS PTY. LTD. (IN LIQUIDATION)

11.15 a.m. NATIONWIDE TRUCK RECONDITIONING OF AUSTRALIA PTY. LTD. (IN LIQUIDATION)

11.30 a.m. R. E. & M. Z. JONES PTY. LTD. (IN LIQUIDATION)

11.45 a.m. W. D. & L. M. WILSON PTY. LTD. (IN LIQUIDATION)

Dated 22 May 1980

E. T. BENT, Liquidator

Bent & Cogle, public accountants, 144 Jolimont Road,  
East Melbourne 7347

In the Supreme Court of Victoria—Co. 11283—In the matter of the *Companies Act 1961*; and in the matter of **PETCHEM LIMITED**—Notice of Winding Up Order

Winding Up Order made 15 May 1980.

Name and address of Liquidator: Robert Arthur Waters, 460 Bourke Street, Melbourne.

B. J. O'DONOVAN, Crown Solicitor for the Commonwealth and Solicitor for the Petitioner 7322

The *Companies Act 1961*

**I.S.S. MANAGEMENT (AUSTRALIA) PTY. LTD. (IN LIQUIDATION)**

Notice is hereby given that pursuant to section 272 of the *Companies Act 1961*, a General Meeting of members of the company will be held on the 23rd Floor at 535 Bourke Street, Melbourne on Friday 4 July 1980 at 9.30 in the forenoon for the purpose of having laid before them an account showing how the winding up has been conducted and the property of the company disposed of and of hearing any explanation that may be given by the liquidator.

Dated 26 May 1980

A. S. HOME, Liquidator

Irish Young & Outhwaite, 535 Bourke Street, Melbourne, Victoria 3000 7351

*Companies Act 1961*

**G. J. MARINE PTY. LTD. (IN LIQUIDATION)**

Notice is hereby given that the final meeting of Creditors of the above Company will be held at 583 Hampton Street, Hampton, 3188 on 25 June 1980.

*Business:*

To receive a final report of the Liquidation on the winding up.

7352

E. P. TAYLOR, Liquidator

The *Companies Act 1961*

**PABRU HOLDINGS PTY. LTD. (IN LIQUIDATION)**

**NOTICE CONVENING FINAL MEETING OF MEMBERS, PURSUANT TO SECTION 272**

Notice is hereby given pursuant to Section 272 of the *Companies Act 1961* that a meeting of the members of the abovenamed company will be held on Friday, 27 June 1980 at 9.00 a.m. at the office of D. C. Stewart, Chartered Accountant, Suite 5, 38 Ross Smith Avenue, Frankston, Vic. 3199 for the purpose of having an account laid before them showing the manner in which the winding up has been conducted and the property of the company disposed of and hearing any explanations that may be given by the Liquidator.

Dated 23 May 1980

B. E. FORDHAM, Liquidator

Fordham, Williams & Co., 521 Toorak Road, Toorak, 3142. Telephone: 24 7511 7353

In the matter of the *Companies Act 1961*; and in the matter of **FOLDIN INDUSTRIES PTY. LIMITED (in Liquidation)**—Notice of Final General Meeting

Take notice that the affairs of the abovenamed Company are now fully wound up and that in pursuance of Section 272 (1) of the *Companies Act 1961*, a General Meeting of the Company will be held at the office of Messrs B. O. Smith & Son, Chartered Accountants, 23rd Floor, 500 Collins Street, Melbourne on Monday 16 June 1980 at three o'clock in the afternoon for the purpose of laying before it an account showing how the winding up has been conducted and the property of the Company disposed of and giving any explanation thereof.

Dated 27 May 1980

7361

J. S. ROMANIS, Liquidator

The *Companies Act 1961*

**F. X. WALSH LAND DEVELOPMENT CO. PTY. LTD. (IN MEMBERS' VOLUNTARY LIQUIDATION)**

Notice is hereby given that at an Extraordinary General Meeting of Members of the abovenamed Company held on 26 May 1980 it was resolved that the Company be

wound up voluntarily and that Herbert A. B. McWilliam of Touche Ross & Co., 11th Floor, 440 Collins Street, Melbourne be appointed Liquidator.

Notice is also given that after 21 days from this date, I shall proceed to distribute the assets. All Creditors having any claims against the Company should furnish particulars of their claims by that date, otherwise I shall proceed to distribute the assets without regard to their claim.

Dated 26 May 1980

H. A. B. McWILLIAM, chartered accountant, Touche Ross & Co., 11th Floor, 440 Collins Street, Melbourne. Vic. 3000 7362

The *Companies Act 1961*—Section 291 and Regulation 54—In the matter of **WILLIAM NEWMAN & SONS (AUST) HOLDINGS PTY. LTD. (in Liquidation)**

Take notice that as Liquidator of the abovenamed Company I have fixed Wednesday 11 June 1980 as the day on or before which creditors of the company are to prove their debts or claims and to establish any title they may have to priority under section 292 or be excluded from the benefit of a first and final distribution made before such debts are proved or as the case may be from objecting to such distribution.

Dated 28 May 1980

R. E. RAMSAY, Liquidator

Wallace, McMullin & Smail, chartered accountants, 499 St. Kilda Road, Melbourne, 3004 7363

Form 92

*Companies Act 1961*

**WORRAN PROPERTIES PTY. LTD.**

**NOTICE OF MEETING OF CREDITORS PURSUANT TO SECTION 260**

Notice is hereby given that a meeting of creditors of the abovenamed company will be held at the offices of Messrs Peat, Marwick, Mitchell and Co., 18th Floor, 500 Bourke Street, Melbourne on Tuesday, 17 June 1980 at 10.00 a.m., the company having convened a meeting of its members to be held on the same day for the purpose of considering a Special Resolution that the company be wound up voluntarily.

Dated 28 May 1980

7364

R. CHILDS, Director

*Companies Act 1961*

**B. & S. COLLINS PTY. LTD.**

**NOTICE OF MEETING OF CREDITORS**

Notice is hereby given that pursuant to section 260 of the *Companies Act 1961* a meeting of the creditors of B. & S. Collins Pty. Ltd. will be held at the Boardroom, the Institute of Chartered Accountants, 140 Queen Street, Melbourne on 9 June 1980, at 11.00 a.m., the Company having convened a meeting of its members for the same day for the purpose of considering and, if thought fit, passing the special resolution that the company be wound up voluntarily.

Dated 14 May 1980

P. WORSLEY, Secretary

Duesbury Johnston & Marks, chartered accountants, 114 William Street, Melbourne, Vic. 3000 7365

*Companies Act 1961*—In the matter of **MARPEN NOMINEES PTY. LTD.**—Notice of Meeting of Creditors Pursuant to Section 260

Notice is hereby given that a meeting of Creditors of the abovementioned Company will be held at 177 Eley Road Blackburn South on Friday, 20 June 1980, at 4.30 p.m. The company having convened an extraordinary general meeting of the members for the same day for the purpose of considering a special resolution that the Company be wound up voluntarily.

Dated 21 May 1980

S. RUSSELL, Director  
CLIVE MORRIS

Clive Morris & Staff, public accountants, 177 Eley Road, Blackburn South 3130. Telephone 232 3027 7366

In the matter of the *Companies Act 1961*, Section 260; and in the matter of PIONEER UNIFORM SERVICE PTY. LTD.—  
Notice of Meeting of Creditors

Notice is hereby given that a meeting of the creditors of Pioneer Uniform Service Pty. Ltd. will be held at the offices of Hungerford Hancock and Offner, 10th Floor, 44 Market Street, Melbourne in the State of Victoria at 10.30 a.m. on Friday, 6 June 1980.

#### Agenda

To consider, and if agreed, pass the following Special Resolution pursuant to Section 261

"That Ernest Harding Niemann (chartered accountant) and Tim Arthur Jonas (chartered accountant) both of 10th Floor, 44 Market Street, Melbourne, be appointed as Joint Liquidators for the purpose of the winding up."

Dated 27 May 1980

R. BUCHANAN, Director

A person is not entitled to vote as a creditor at the meeting unless he has lodged with the Chairman of the meeting a proof of debt which he claims to be due to him from the company.

HUNGERFORD HANCOCK & OFFNER, 8th Floor, 44  
Market Street, Melbourne 3000 7367

#### *Companies Act 1961*, Section 272

##### NOTICE OF FINAL MEETING OF MEMBERS

#### STEWART WRIGHTSON (VIC.) PTY. LIMITED (IN LIQUIDATION)

Notice is hereby given that a meeting of the members of Stewart Wrightson (Vic.) Pty. Limited (in Liquidation) will be held at 16th Floor, 351 Collins Street, Melbourne on 30 June 1980 at 9.00 a.m.

#### Agenda

To lay before the meeting the liquidator's account showing how the winding up has been conducted and the property of the company has been disposed of, and to give any explanation of the account which may be required.

The business of Stewart Wrightson (Vic.) Pty. Ltd. (in Liquidation) is being carried on by Stewart Wrightson Australia Ltd. at the same address.

Dated 22 May 1980

7368

MAX G. CHAPMAN, Liquidator

#### The *Companies Act 1961*

#### MID-PACIFIC & INTERNATIONAL INSURANCE CO. PTY. LTD. (IN LIQUIDATION)

##### NOTICE CONVENING FINAL MEETING OF MEMBERS AND CREDITORS, PURSUANT TO SECTION 272

Notice is hereby given pursuant to section 272 of the *Companies Act 1961*, that a meeting of the abovenamed Company and its creditors will be held in the offices of Wallace, McMullin & Smail, 499 St. Kilda Road, Melbourne 3004, on Wednesday, 30 June 1980, at 10.30 a.m. for the purpose of having an account laid before them showing the manner in which the winding up has been conducted and the property of the Company disposed of and of hearing any explanations that may be given by the Liquidator.

Dated 28 May 1980

J. M. WALSH, Liquidator

Wallace, McMullin & Smail, chartered accountants

7369

#### The *Companies Act 1961*

#### CRAMDEN CELLARS PTY. LTD. (IN LIQUIDATION)

##### NOTICE CONVENING FINAL MEETING OF MEMBERS AND CREDITORS, PURSUANT TO SECTION 272

Notice is hereby given pursuant to section 272 of the *Companies Act 1961*, that a meeting of the abovementioned Company and its creditors will be held in the offices of Wallace, McMullin & Smail, 499 St. Kilda Road, Melbourne 3004, on Wednesday, 30 June 1980, at 10.00 a.m. for the

purpose of having an account laid before them showing the manner in which the winding up has been conducted and the property of the Company disposed of and of hearing any explanations that may be given by the Liquidator.

Dated 28 May 1980

A. M. HORSBURGH, Liquidator

Wallace, McMullin & Smail, chartered accountants

7370

#### *Companies Act 1961*, Section 272 (2)

#### TOORALAC MILK PRODUCTS PTY. LTD. (IN LIQUIDATION)

##### NOTICE OF FINAL MEETING

Notice is hereby given that pursuant to section 272 (2) of the *Companies Act 1961*, a general meeting of members of Tooralac Milk Products Pty. Ltd. will be held at Messrs. Duesbury Johnston & Marks, 19th Floor, 114 William Street, Melbourne 3000, on 30 June 1980, at 10.00 a.m.

The purpose of the meeting is to lay accounts before it, showing the manner in which the winding up has been conducted and the property of the company disposed of, and of hearing any explanation that may be given by the liquidator.

Dated 23 May 1980

W. A. LEEMING, Liquidator

Duesbury Johnston & Marks, 114 William Street, Melbourne, Vic. 3000 7371

#### *Companies Act 1961*, Section 272 (2)

#### EPHOS PROPRIETARY LIMITED (IN VOLUNTARY LIQUIDATION)

##### NOTICE OF FINAL MEETING

Notice is hereby given that a general meeting of the members of the abovenamed Company will be held at the office of Hosking Quinn & Partners, 4th Floor, 422 Collins Street, Melbourne on Tuesday 1 July 1980 at 2.30 p.m. for the purpose of having an account laid before them showing the manner in which the winding up has been conducted and the property of the company disposed of.

7372

C. C. RIVINGTON, Liquidator

In the Supreme Court of Victoria—1980 Co. No. 11287—In the matter of the *Companies Act 1961*; and in the matter of ALLYSTEEL & CONCRETE (VIC.) PTY. LTD.—  
Notice of Winding Up Order

Winding Up Order: Made 15 May 1980.

Name and address of Liquidator: Bruce Edward Fordham, 521 Toorak Road, Toorak.

B. J. O'DONOVAN, Crown Solicitor for the Commonwealth and solicitor for the petitioner 7373

In the Supreme Court of Victoria—1980 Co. No. 11283—In the matter of the *Companies Act 1961*; and in the matter of FIRE RETARD (AUST.) PTY. LTD.—  
Notice of Winding Up Order

Winding Up Order: Made 15 May 1980.

Name and address of Liquidator: Kevin James Browne, 1 Palmerston Crescent, South Melbourne.

B. J. O'DONOVAN, Crown Solicitor for the Commonwealth and solicitor for the petitioner 7374

In the Supreme Court of Victoria—1980 No. Co. 11340—  
In the matter of the *Companies Act 1961*; and in the matter of ORGANVILLE NOMINEES PROPRIETARY LIMITED (Provisional Liquidator Appointed)—  
Advertisement of Petition

Notice is hereby given that a Petition for the winding up of the abovenamed Company by the Supreme Court was on 16 May 1980 presented by Organville Nominees Proprietary Limited and that the said Petition is directed to be heard before the Court sitting at the Law Courts, William Street, Melbourne in the State of Victoria on Thursday 24 July 1980 at 10.30 o'clock in the forenoon; and any Creditor or Contributory of the said Company desiring to support or oppose the making of an Order on the said Petition may appear at the time of the Hearing by himself or his Counsel for that purpose; and a copy of the Petition will be furnished to any Creditor or

Contributory of the said Company requiring the same by the undersigned on payment of the regulated charge for the same.

The Petitioner's address is 1114 High Street, Armadale in the State of Victoria.

The Petitioner's solicitors are Messrs Weigall & Crowther, 12th Floor, 459 Little Collins Street, Melbourne in the said State.

WEIGALL & CROWTHER, solicitors for the petitioner

NOTE—Any person who intends to appear at the Hearing of the said Petition must serve on or send by post to the abovenamed Solicitors, a notice in writing of his intention to do so. The Notice must state the name and address of the person, or, if a firm, the name and address of the firm and must be signed by the person or firm, or his or their solicitor (if any) and must be served, or if posted, must be sent by post in sufficient time to reach the abovenamed not later than 4.00 o'clock in the afternoon of 23 July 1980. 7380

In the Supreme Court of Victoria—1980 No. Co. 11340—In the matter of the *Companies Act 1961*; and in the matter of ORGANVILLE NOMINEES PROPRIETARY LIMITED (Provisional Liquidator Appointed)—Notice of Appointment of Provisional Liquidator

Order for appointment of an Official Liquidator as provisional liquidator made 20 May 1980.

Name and address of Provisional Liquidator: Geoffrey Ormond Harrison, 12th Floor, 440 Collins Street, Melbourne, 3000.

Dated 23 May 1980

WEIGALL & CROWTHER, solicitors for the petitioner  
Organville Nominees Proprietary Limited 7381

In the Supreme Court of Victoria—In the matter of the *Companies Act 1961*; and in the matter of J.C.P. AUTO PARTS PTY. LTD.

Notice is hereby given that a petition for the winding up of the abovenamed Company by the Supreme Court was on 26 May 1980 presented by Kevin Patrick Brady, Deputy Commissioner of Taxation of the Commonwealth of Australia and that the said petition is directed to be heard before the Court sitting at the Fifteenth Court, Law Courts, Lonsdale Street, Melbourne, at the hour of 10.30 o'clock in the forenoon on 12 June 1980 and any creditor or contributory of the said company desiring to support or oppose the making of an order on the said petition may appear at the time of hearing by himself or his Counsel for the purpose; and a copy of the said petition will be furnished to any creditor or contributory of the said company requiring the same by the undersigned on payment of the regulated charge for the same.

The Petitioner's official address is 350 Collins Street, Melbourne.

The Petitioner's Solicitor is B. J. O'Donovan, Crown Solicitor for the Commonwealth of 99 Queen Street, Melbourne.

B. J. O'DONOVAN

NOTE—Any person who intends to appear on the hearing of the said petition must serve on or send by post to the abovenamed B. J. O'Donovan, notice in writing of his intention so to do. The notice must state the name and address of the person, or, if a firm, the name and address of the firm, and must be signed by the person or firm, or his, or their solicitor (if any), and must be served, or, if posted, must be sent by post in sufficient time to reach the abovenamed not later than 4 o'clock in the afternoon of 11 June 1980. 7375

In the Supreme Court of Victoria—In the matter of the *Companies Act 1961*; and in the matter of W. A. BAD-DELEY PTY. LTD.

Notice is hereby given that a petition for the winding up of the abovenamed Company by the Supreme Court was on 26 May 1980 presented by Kevin Patrick Brady, Deputy Commissioner of Taxation of the Commonwealth of Australia and that the said petition is directed to be

heard before the Court sitting at the Fifteenth Court, Law Courts, Lonsdale Street, Melbourne, at the hour of 10.30 o'clock in the forenoon on 12 June 1980 and any creditor or contributory of the said company desiring to support or oppose the making of an order on the said petition may appear at the time of hearing by himself or his Counsel for the purpose; and a copy of the said petition will be furnished to any creditor or contributory of the said company requiring the same by the undersigned on payment of the regulated charge for the same.

The Petitioner's official address is 350 Collins Street, Melbourne.

The Petitioner's Solicitor is B. J. O'Donovan, Crown Solicitor for the Commonwealth of 99 Queen Street, Melbourne.

B. J. O'DONOVAN

NOTE—Any person who intends to appear on the hearing of the said petition must serve on or send by post to the abovenamed B. J. O'Donovan, notice in writing of his intention so to do. The notice must state the name and address of the person, or, if a firm, the name and address of the firm, and must be signed by the person or firm, or his, or their solicitor (if any), and must be served, or, if posted, must be sent by post in sufficient time to reach the abovenamed not later than 4 o'clock in the afternoon of 11 June 1980. 7376

In the Supreme Court of Victoria—In the matter of the *Companies Act 1961*; and in the matter of B.B.A. AIR CARGO PROPRIETARY LIMITED

Notice is hereby given that a petition for the winding up of the abovenamed Company by the Supreme Court was on 26 May 1980 presented by Kevin Patrick Brady, Deputy Commissioner of Taxation of the Commonwealth of Australia and that the said petition is directed to be heard before the Court sitting at the Fifteenth Court, Law Courts, Lonsdale Street, Melbourne, at the hour of 10.30 o'clock in the forenoon on 12 June 1980 and any creditor or contributory of the said company desiring to support or oppose the making of an order on the said petition may appear at the time of hearing by himself or his Counsel for the purpose; and a copy of the said petition will be furnished to any creditor or contributory of the said company requiring the same by the undersigned on payment of the regulated charge for the same.

The Petitioner's official address is 350 Collins Street, Melbourne.

The Petitioner's Solicitor is B. J. O'Donovan, Crown Solicitor for the Commonwealth of 99 Queen Street, Melbourne.

B. J. O'DONOVAN

NOTE—Any person who intends to appear on the hearing of the said petition must serve on or send by post to the abovenamed B. J. O'Donovan, notice in writing of his intention so to do. The notice must state the name and address of the person, or, if a firm, the name and address of the firm, and must be signed by the person or firm, or his, or their solicitor (if any), and must be served, or, if posted, must be sent by post in sufficient time to reach the abovenamed not later than 4 o'clock in the afternoon of 11 June 1980. 7377

In the Supreme Court of Victoria—In the matter of the *Companies Act 1961*; and in the matter of VIDEO CONCEPT PRODUCTIONS PTY. LTD.

Notice is hereby given that a petition for the winding up of the abovenamed Company by the Supreme Court was on 26 May 1980 presented by Kevin Patrick Brady, Deputy Commissioner of Taxation of the Commonwealth of Australia and that the said petition is directed to be heard before the Court sitting at the Fifteenth Court, Law Courts, Lonsdale Street, Melbourne, at the hour of 10.30 o'clock in the forenoon on 12 June 1980 and any creditor or contributory of the said company desiring to support or oppose the making of an order on the said petition may appear at the time of hearing by himself or his Counsel for the purpose; and a copy of the said

petition will be furnished to any creditor or contributory of the said company requiring the same by the undersigned on payment of the regulated charge for the same.

The Petitioner's official address is 350 Collins Street, Melbourne.

The Petitioner's Solicitor is B. J. O'Donovan, Crown Solicitor for the Commonwealth of 99 Queen Street, Melbourne.

B. J. O'DONOVAN

NOTE—Any person who intends to appear on the hearing of the said petition must serve on or send by post to the abovenamed B. J. O'Donovan, notice in writing of his intention so to do. The notice must state the name and address of the person, or, if a firm, the name and address of the firm, and must be signed by the person or firm, or his, or their solicitor (if any), and must be served, or, if posted, must be sent by post in sufficient time to reach the abovenamed not later than 4 o'clock in the afternoon of 11 June 1980. 7378

In the Supreme Court of Victoria—In the matter of the Companies Act 1961; and in the matter of GRAYLING NOMINEES PTY. LTD.

Notice is hereby given that a petition for the winding up of the abovenamed Company by the Supreme Court was on 26 May 1980 presented by Kevin Patrick Brady, Deputy Commissioner of Taxation of the Commonwealth of Australia and that the said petition is directed to be heard before the Court sitting at the Fifteenth Court, Law Courts, Lonsdale Street, Melbourne, at the hour of 10.30 o'clock in the forenoon on 12 June 1980 and any creditor or contributory of the said company desiring to support or oppose the making of an order on the said petition may appear at the time of hearing by himself or his Counsel for the purpose; and a copy of the said petition will be furnished to any creditor or contributory of the said company requiring the same by the undersigned on payment of the regulated charge for the same.

The Petitioner's official address is 350 Collins Street, Melbourne.

The Petitioner's Solicitor is B. J. O'Donovan, Crown Solicitor for the Commonwealth of 99 Queen Street, Melbourne.

B. J. O'DONOVAN

NOTE—Any person who intends to appear on the hearing of the said petition must serve on or send by post to the abovenamed B. J. O'Donovan, notice in writing of his intention so to do. The notice must state the name and address of the person, or, if a firm, the name and address of the firm, and must be signed by the person or firm, or his, or their solicitor (if any), and must be served, or, if posted, must be sent by post in sufficient time to reach the abovenamed not later than 4 o'clock in the afternoon of 11 June 1980. 7379

Creditors, next of kin and others having claims against the estate of Herbert Bennett Thomas late of 49 James Street, Pakenham in the State of Victoria Newspaper Proprietor deceased who died on 13 July 1979 are required by the Executor Florrie Gefferson Thomas of 49 James Street, Pakenham to send particulars of their claims to the said Executor care of Messrs F. R. Monotti & Co. of 13 Scott Street, Dandenong, Solicitors, by 1 August 1980 after which date they will distribute the assets of the said estate having regard only to the claims of which they then have notice.

F. R. MONOTTI & CO., solicitors, 13 Scott Street, Dandenong 7242

PERCIVAL FREDERICK GORDON NASH, late of Main Street, Lethbridge, in the State of Victoria, retired farmer, DECEASED

Creditors, next of kin and others having claims in respect of the Estate of the Deceased who died on 13 July 1979 and Probate of whose Will was granted by the Supreme Court of Victoria on 27 March 1980 to Joseph Glynn Desmond of 1 Malop Street Geelong Solicitor the executor named

therein, are required to send particulars of their claims to the said executor care of the undermentioned Solicitors before 14 August 1980, after which date the executor will distribute the assets having regard only to the claims of which he shall then have had notice.

FRASER DESMOND & CO., solicitors, 1 Malop Street, Geelong 7243

Creditors, next of kin and others having claims in respect of the Estate of Mardi Helena Cameron late of "Chelwood Court" Metung Married Woman deceased who died on 20 February 1980 are required to send particulars of their claims to the Administrator care of Agg & Engel, 109 Main Street, Bairnsdale by 13 July 1980 after which date the Administrator will convey or distribute the assets having had regard only to the claims of which he then has notice.

AGG & ENGEL, solicitors, 109 Main Street, Bairnsdale 7244

ELIZABETH MURIEL MALKIN, formerly of 257 Autumn Street, Geelong West, but late of Grace McKellar House, Ballarat Road, North Geelong, in the State of Victoria, married woman, DECEASED

Creditors, next of kin and others having claims in respect to the abovenamed deceased (who died on 25 September 1979) are required by the Executors (Milton William Malkin of 66 Savoy Drive, Florida Gardens in the State of Queensland, Chemist and Neil Cyril Reseigh Malkin of 116 Burdoo Drive, Grovedale in the State of Victoria Purchasing Officer) to send particulars of such claims to the undermentioned firm by 28 July 1980 after which date the said Executors may convey or distribute the assets having regard only to the claims of which they then have notice.

HARWOOD & PINCOTT, solicitors, of 77 Moorabool Street, Geelong 7245

EDITH MARY EDGAR, late of 21 Chester Street, Herne Hill, in the State of Victoria, widow, DECEASED

Creditors, next of kin and others having claims in respect of the abovenamed deceased (who died on 22 October 1979) are required by the Executrix (Audrey Mary Edgar of 21 Chester Street, Herne Hill in the said State Retired) and the Executors (David Walter Edgar of "Nerrinyerie", Harrow in the said State, Farmer and Charles William Crosbie of 38 Margate Street, Barwon Heads in the said State Retired) to send particulars of such claims to the undermentioned firm by 21 July 1980 after which date the said Executrix and Executors may convey or distribute the assets having regard only to the claims of which they then have notice.

HARWOOD & PINCOTT, solicitors, of 77 Moorabool Street, Geelong 7246

ALBERT KENNETH BLOCKLEY, late of 15 Dennis Street, Northcote, retired, DECEASED

Creditors, next of kin and others having claims against the estate of the said deceased who died on 10 April 1980 are to send particulars of their claims to John Kenneth Blockley C/- 452 High Street, Northcote by 30 July 1980 after which date he will distribute the assets having regard only to the claims of which he then has notice.

WALSH JOHNSTON & CO., solicitors, 452 High Street, Northcote 7254

JEMIMA JARDEN RUDD, late of Pine View Lodge, 90 Bradshaw Street, Essendon, widow, DECEASED

Creditors, next of kin and others having claims against the estate of the said deceased who died on 25 March 1980 are to send particulars of their claims to Elwyn Needham C/- 452 High Street, Northcote by 30 July 1980 after which date she will distribute the assets having regard only to the claims of which she then has notice.

WALSH JOHNSTON & CO., solicitors, 452 High Street, Northcote 7255

Creditors, next of kin and others having claims against the estate of Alice Bathsheba Baines late of 10 Masters Street, Dandenong in the State of Victoria Widow deceased who died on 10 February 1980 are required by the Executors Douglas Raymond Lindsay, of 10 Masters

Street, Dandenong and Henry John Thornton of 22 Peacock Street, Mirboo North to send particulars of their claims to the said Executors care of Messrs F. R. Monotti & Co. of 13 Scott Street, Dandenong, Solicitors, by 11 August 1980 after which date they will distribute the assets of the said estate having regard only to the claims of which they then have notice.

F. R. MONOTTI & CO., solicitors, 13 Scott Street, Dandenong 7256

Creditors, next of kin and others having claims against the estate of Nunzio Laudani late of 41 Langhorne Street, Dandenong in the State of Victoria Gentleman deceased who died on 14 November 1979 are required by the Executor Marius Charles Giosserano of 93 Springvale Road, Springvale to send particulars of their claims to the said Executors care of Messrs F. R. Monotti & Co. of 13 Scott Street, Dandenong, Solicitors, by 11 August 1980 after which date they will distribute the assets of the said estate having regard only to the claims of which they then have notice.

F. R. MONOTTI & CO., solicitors, 13 Scott Street, Dandenong 7257

ALAN LESLIE MONEGHETTI, late of Blowhard, farmer, who died on 28 February 1980

Creditors, next of kin and all other persons having claims against the estate of the deceased are required to send particulars to the Executors The Union-Fidelity Trustee Company of Australia Limited and Henry Joseph Moneghetti at 101 Lydiard Street North Ballarat on or before 29 July 1980 after which date the Executors will distribute the assets having regard only to the claims of which they shall then have notice.

MORROW & MORROW, solicitors, Ballarat 7288

Creditors, next of kin and others having claims in respect of the Estate of Audrey Verna Millar formerly of 125 Highfield Road Camberwell but late of 16 Olive Avenue Mount Waverley in the State of Victoria Married Woman deceased who died on 7 November 1979 are to send particulars of their claims to The Union-Fidelity Trustee Company of Australia Limited at 100 Exhibition Street Melbourne in the said State by 31 July 1980 after which date it will distribute the assets having regard only to the claims of which it then has notice.

ABBOTT, STILLMAN & WILSON, solicitors, 406 Lonsdale Street, Melbourne 7289

MARY JANE WALTERS, late of Unit 1, 372 Old Cleveland Road, Coorparoo, Queensland, pensioner, DECEASED

Creditors, next of kin and others having claims in respect of the estate of the deceased who died on 1 December 1977 are required by the executors Frank Roy Harden Walters of 49 Payne Street Indooroopilly Queensland Real Estate Agent and Maragaret Joan Barber of 4/75 King Street Annerley Queensland Married Woman to send particulars to them care of the under-mentioned solicitors by 13 July 1980 after which date the executors may convey or distribute the assets having regard only to the claims of which they then have notice.

HADEN SMITH & FITCHETT, solicitors, 423 Bourke Street, Melbourne 7324

DOROTHY AUGUSTA BUTLER WALSH, late of Wynnstey Private Hospital, 21 Wynnstey Road, Prahran, spinster, DECEASED

Creditors, next of kin and others having claims against the Estate of the said deceased who died on 29 December 1979 are to send particulars of their claims to Ian Terres Sutcliffe C/- Messrs Blake & Riggall Solicitors 140 Williams Street Melbourne by 27 August 1980 after which date he will distribute the assets having regard only to the claims of which he then has notice.

BLAKE & RIGGALL, solicitors, 140 William Street, Melbourne 7325

FLORENCE EMILY LIA, late of 220 Raleigh Street, Thornbury, widow, DECEASED

Creditors, next of kin and others having claims in respect of the Estate of the deceased who died on 21 November, 1979 are requested to send particulars of their claims to the Executor Mervyn Joseph Lia care of the undersigned Solicitor by 29 July, 1980 after which date the said Executor will proceed to distribute the Estate having regard only to the claims of which he then has notice.

MARJORY C. COATES, solicitor, of 422 Collins Street, Melbourne, 3000 7326

Creditors, next of kin and others having claims against the Estate of Jean Alice Marie Thompson late of "Cambrai" Private Nursing Home, 65 Westbury Street East St. Kilda Spinster who died on 8 January, 1980 are requested to send particulars of their claims to The Union-Fidelity Trustee Company of Australia Limited of 100 Exhibition Street Melbourne by 29 July 1980 after which date the said Company will distribute the assets having regard only to the claims of which it shall then have notice.

STEDMAN CAMERON MEARES & HALL, solicitors, 143 Queen Street, Melbourne 7327

Creditors, next of kin and others having claims in respect of the estate of Clendinnen Martin McKenzie late of 43 Marriage Road East Brighton Gentleman deceased who died on 6 October 1979 are to send particulars of their claims to The Equity Trustees Executors and Agency Company Limited of 472 Bourke Street Melbourne by 29 July 1980 after which date it will distribute the assets having regard only to the claims of which it then has notice.

MARTIN & MARTIN, solicitors, 37 Queen Street, Melbourne 7328

VERONICA ETHEL FEATHERSTONE, late of Unit 4, 15 Barton Street, Reservoir, widow, DECEASED

Creditors, next of kin and others having claims in respect of the estate of the deceased (who died on 15 January 1980) are required by the executor of her Will Leslie Frank Featherstone of 8 Bickley Avenue, Thomastown in the State of Victoria, Fitters Assistant, to send particulars of their claims to the said executor care of his solicitors Messrs McNab & McNab of 21 Gorge Road, South Morang by 28 July 1980 after which date he may convey or distribute the assets in the estate of the said deceased having regard only to the claims of which the said executor then has notice.

McNAB & McNAB, solicitors, 20 Queen Street, Melbourne, 3000 7329

Creditors, next of kin and all others interested in the estate of Isak Wechter late of 258A Station Street, Fairfield in the State of Victoria Cleaning Cloth Merchant deceased (who died on 11 December 1976) are required to send particulars of their claims to the Administratrix of the Will of the deceased Celia Wechter care of John W. McComas & Co., 325 Collins Street, Melbourne by 29 July 1980 after which date she will distribute the assets having regard only to the claims of which she then has notice.

JOHN W. McCOMAS & CO., solicitors, 325 Collins Street, Melbourne 7330

STANLEY ALBERT WOOLARD, late of 6 Karrin Court, Ashwood, labourer, DECEASED

Creditors, next of kin and others having claims in respect of the estate of the deceased who died on 7 December 1979, are required by the Administrator John Lionel Woolard of 28 Norfolk Avenue, Wantirna South, to send particulars to him at 376 Collins Street, Melbourne, by 30 July 1980 at which date the Administrator may convey or distribute the assets having regard only to the claims of which he then has notice.

Dated 22 May 1980

JOHN P. RHODEN, solicitors, 376 Collins Street, Melbourne 7331

Creditors, next of kin and others having claims in respect of the Estate of John McArthur late of 36 Hambleton Street, Albert Park Retired who died on 25 April 1980 are to send particulars of their claims to Oswald Carl Hayton and John Watson McCallum care of the undersigned by 31 July 1980 after which date they will distribute the assets having regard only to the claims of which they then have notice.

COOK & McCALLUM, solicitors, 422 Collins Street, Melbourne 7332

#### STATUTORY NOTICE TO CREDITORS

Pursuant to the *Trustee Act 1958* notice is hereby given that all persons having claims against the Estate of Myftar Caush (also known as Peter Caush) late of Marlo in the State of Victoria, Farmer deceased who died on 19 September 1979 and probate of whose Will was granted by the Supreme Court of the said State in its Probate Jurisdiction on 28 March 1980 to Margaret Gibson Adams of Marlo in the said State, Farmer are hereby required to send particulars in writing to the undersigned at his office hereunder mentioned on or before 5 August 1980 after which date the said Margaret Gibson Adams will proceed to distribution of the assets of the said Myftar Caush deceased, which shall have come to her hands amongst the persons entitled thereto, having regard only to the claims of which she shall then have had notice.

And notice is hereby further given that the said Margaret Gibson Adams will not be liable for the assets so distributed or any part thereof to any person of whose claim he shall not have had notice as aforesaid.

Dated 23 May 1980

BRIAN G. LIGHTFOOT, care of Messrs Warren, Graham & Murphy, solicitors, 119 Main Street, Bairnsdale, Vic. 3875, proctor for the said Margaret Gibson Adams

7333

IRENE JUNE FARRAR, late of 40 Summerhill Avenue, East Malvern, in the State of Victoria, married woman, DECEASED

Creditors, next of kin and others having claims in respect of the deceased who died on 10 October 1979 are required to send particulars of their claims to National Trustees Executors and Agency Company of Australasia Limited of 95 Queen Street, Melbourne the Executor appointed by the deceased's Will by 31 July 1980 after which date it will distribute the assets having regard only to the claims of which it then has notice.

LESTER, FIELDEN & FARAONE, solicitors, 14 Haughton Road, Oakleigh 7334

Creditors, next of kin and others having claims in respect of the estate of James Sypott late of 10 Pine Street, Brighton in the State of Victoria Retired Grazier deceased who died on 16 May 1978 are to send particulars of their claims to Sydney Robert Young, Salesman, Phyllis Jean Young, Married Woman, both of 6 Miles Street, Bentleigh in the said State and Reginald Charles Butler Solicitor of 36 Jasper Road, Moorabbin in the said State care of the undermentioned Solicitors by 28 July 1980 after which date they will distribute the assets having regard only to the claims to which they then have notice.

REGINALD C. BUTLER & CO., solicitors, 312 Centre Road, Bentleigh 7335

Creditors, next of kin and others having claims in respect of the estate of Maud Mary Mowat late of 102 Ascot Street, South Ballarat Widow deceased who died on 1 March 1980 are required to send particulars of their claims to the Executor The Union-Fidelity Trustee Company of Australia Limited at its address 101 Lydiard Street, North Ballarat by 29 July 1980 after which date the said Company will distribute the assets having regard only to the claims of which it then has notice.

BAIRD & MCGREGOR, solicitors, Ballarat 7336

Pursuant to the *Trustee Act 1958* notice is hereby given that all persons having claims against the estate of Joyce Webb Marriott late of Villa 6, 11 Bowen Street Kew in the State of Victoria, Home Duties, deceased who died on 29 October 1979 and Probate of whose Will was granted by

the Supreme Court of the said State in its Probate Jurisdiction on 1 February 1980 to Lynette Joan McDermott of 35 Anzac Road Trafalgar in the said State are hereby required to send particulars in writing of such claims to the said Lynette Joan McDermott c/- Wardlaw Burnes & Co., Solicitors, 882 Whitehorse Road Box Hill in the said State, on or before 29 June 1980 after which date the said Lynette Joan McDermott will proceed to distribute the assets of the said Joyce Webb Marriott deceased which shall have come to her hands amongst the persons entitled thereto, having regard only to the claims of which she shall then have had notice. And notice is hereby further given that the said Lynette Joan McDermott will not be liable for the assets so distributed or any part thereof to any person of whose claims she shall not have had notice as aforesaid.

Dated 21 May 1980

WARDLAW BURNES & CO., of 882 Whitehorse Road, Box Hill, proctors for the said Lynette Joan McDermott

7337

JESSIE MARY MCKENZIE, formerly of Mount Alvernia Hospital, Lily Street, Bendigo, in the State of Victoria, but late of the Bendigo Home and Hospital for the Aged, 100 Barnard Street, Bendigo, aforesaid, spinster, DECEASED

Creditors, next of kin and other persons having claims against the Estate of the said deceased who died on 11 April 1980 are required to send particulars of same to the Executor Harry Angus in care of the undersigned on or before 15 August 1980 after which date he will distribute the assets having regard only to the claims of which he then has notice.

DWYER & BENNETT, barristers and solicitors, 201 Campbell Street, Swan Hill 7338

URTLE LEMUAL BENNETT, late of 167 Station Street, Box Hill, in the State of Victoria, storeman, DECEASED

Creditors, next of kin and others having claims in respect of the estate of the deceased (who died on 7 December 1979) are required by the executors Kathleen Shielah Bennett of the same address Widow and William Henry Beamish of Burwood Highway Wantirna in the said State Gentleman to send particulars to them in care of the undersigned by 31 July 1980 after which date the executors may convey or distribute the assets having regard only to the claims of which they then have notice.

Dated 23 May 1980

P. H. PIPPEY & SON, 1 Watts Street, Box Hill, solicitors for the executors 7339

GEORGE FREDERICK CLYNE, late of 135 Roberts Street, Yarraville, in the State of Victoria, pensioner, DECEASED

Creditors, next of kin and others having claims in respect of the Estate of the deceased who died on 16 March 1980 are required by Francis John Clyne of 2 Royston Place, Tullamarine in the said State Retired the Administrator to whom Letters of Administration of the said deceased was granted by the Supreme Court of Victoria to send particulars to him by 4 August 1980 after which date the said Administrator may convey or distribute the assets having regard only to the claims to which he then has notice.

PATRICK J. CANNON, TESTRO & COBURN, solicitors, of 117 Durham Road, Sunshine 3020 7360

DAVID GEORGE CASTLE, late of 54 Molesworth Street, Kew, in the State of Victoria, company director, DECEASED

Creditors, next of kin and others having claims in respect of the estate of the deceased who died on 18 March 1979 are required by The Perpetual Executors and Trustees Association of Australia Ltd. of 50 Queen Street, Melbourne and Leigh Masel of 461 Bourke Street, Melbourne, Solicitor the applicants for a Grant of Administration to send particulars of their claims to the said Applicants in the care of the said company by 31 July 1980 after which date they will convey or distribute the Assets having regard only to the claims of which they then have notice.

PHILLIPS, FOX & MASEL, solicitors for the executors, 461 Bourke Street, Melbourne 7385

DORIS NELLIE ASTON, late of Unit 7, Walmsley Friendship Village, Greeves Drive, Kilsyth, widow, DECEASED

Creditors, next of kin and others having claims in respect of the estate of the deceased who died on 10 February 1980 are required to send particulars thereof to the Executors of her Will Peter John Jackson and William George Campbell, care of the undermentioned Solicitors, on or before 31 July 1980, after which date they will distribute the assets in the estate having regard only to the claims of which they then have notice.

J. M. SMITH & EMMERTON, solicitors, 224 Queen Street, Melbourne 7340

Creditors, next of kin and others having claims in respect of the Estate of Winifred Curtin late of Cornell Street, East Camberwell Spinster deceased who died on 8 April 1980 are to send particulars of their claims to the executors Victor Schelleman and Michael Joseph Mornane care of M. Mornane of 118 Queen Street, Melbourne Solicitor on or before 31 July 1980 after which date they will distribute the estate having regard only to the claims of which they shall have had notice.

M. MORNANE, solicitor, 118 Queen Street, Melbourne 7382

Creditors, next of kin and other persons having claims against the Estate of Salvadora Frances Russell late of 17 Swinburne Avenue, Hawthorn in the State of Victoria, Widow, deceased who died on 29 December 1978 are required to send particulars of their claims to the Executor Brian Philip Russell care of the undermentioned Solicitors by 24 June 1980 after which date they will distribute the assets having regard only as to the claims of which they then have notice.

CARROLL & DILLON, solicitors, 450 Little Collins Street, Melbourne 7383

Creditors, next of kin and other persons having claims against the Estate of Edith Mary Thomas late of Flat 1, 22 Brenbeal Street, North Balwyn in the State of Victoria, Widow, deceased who died on 20 October 1979 are required to send particulars of their claims to the Executor Barry Leonard Thomas care of the undermentioned Solicitors by 25 June 1980 after which date they will distribute the assets having regard only as to the claims of which they then have notice.

CARROLL & DILLON, solicitors, 450 Little Collins Street, Melbourne 7384

PHILLIP SHARP, late of 14 Ercildoune Street, North Caulfield, commercial traveller, DECEASED

Creditors, next of kin and others having claims against the Estate of the said deceased (who died on 24 November 1979) are required to send particulars of their claims to Hadassah Ada Nossell and Hyman Sharp the Executrix and Executor of the deceased's Will, care of the undermentioned Solicitors, by 31 July 1980, after which date they will distribute the assets having regard only to the claims of which they then have notice.

J. OKNO & CO., solicitors, of 213 Lonsdale Street, Melbourne 7350

JAMES DOUGLAS BROATCH, late of 18 Stradbroke Avenue, East Brighton, gentleman, DECEASED

Creditors, next of kin and others having claims in respect of the estate of the deceased who died on 2 April 1980 are required to send particulars thereof to the Executor of his Will John Donald Muir care of the undermentioned Solicitors, on or before 31 July 1980 after which date he will distribute the assets in the estate having regard only to the claims of which he then has notice.

J. M. SMITH & EMMERTON, solicitors, 224 Queen Street, Melbourne 7341

VIOLET VIVIEN CLARE FULTON, formerly of Flat 7, 521 Orrong Road, Armadale, but late of Victoria House Private Hospital, 7 Gordon Street, Toorak, spinster, DECEASED

Creditors, next of kin and others having claims in respect of the estate of the deceased who died on 2 April 1980 are required by the executor Dorothy Helen

Scott of 17 Carinya Crescent, Caulfield Legal Executive to send particulars to her care of the undersigned by 31 July 1980 after which date she may convey or distribute the assets having regard only to the claims of which she then has notice.

R. C. H. BEATTIE, solicitor, 270 Waverley Road, East Malvern 7343

#### Trustee Act 1958

#### NOTICE TO CLAIMANTS

Pursuant to the Trustee Act 1958, creditors next of kin and all other persons having claims in respect of the estate of any deceased person named below are required to send particulars to the legal personal representative or representatives at the addresses stated, after which date the representatives will distribute the assets, having regard only to the claims of which notice has been received:—

Mabel Mills, late of 10 Clive Street, West Footscray, Widow, deceased, who died on 28 April 1980. Claims to the Executor Leslie James Mills of 10 Clive Street, West Footscray, by 31 July 1980—JOHN F. CARROLL, LL.B., solicitor, 4 Paisley Street, Footscray. 7344

In the Supreme Court of the State of Victoria

#### SALE BY THE SHERIFF

On Thursday 10 July 1980 at 10.30 a.m. at Police Station, Malvern (unless process be stayed or satisfied).

All the Estate and Interest (if any) of Thomas P. Colgan (shown on Certificate of Title as Thomas Patrick Colgan) investor of 3/2 Denmark Hill Road, East Hawthorn as joint proprietor with Helena Daphne Colgan, married woman of an estate in fee simple in the land described in Certificate of Title Volume 4907 Folio 277 upon which is erected a brick dwelling known as No. 26 Ranfurly Crescent Glen Iris.

Registered Mortgage Nos. D.714862 and E.64005 affect the said estate and interest.

Terms—Cash only

7386

J. GREEN, Deputy Sheriff

In the Supreme Court of the State of Victoria

#### SALE BY THE SHERIFF

On Wednesday 17 July 1980 at 12.00 noon at the Police Station Geelong (unless process be stayed or satisfied).

All the Estate and Interest (if any) of Rizo Hasanovic, factory worker, of 7 Corrin Court, Norlane, as joint proprietor with Barbara Feric, home duties, of an estate in fee simple in the land described in Certificate of Title Volume 8251 Folio 738 upon which is erected a brick dwelling known as No. 7 Corrin Court, Norlane.

Registered Mortgages Nos. G.666337 and H.780481 affect the said estate and interest.

Terms—Cash only

7387

JOHN GREEN, Deputy Sheriff

In the Supreme Court of the State of Victoria

#### SALE BY THE SHERIFF

On Friday 4 July 1980 at 11.30 a.m. at Police Station Heidelberg (unless process be stayed or satisfied).

All the Estate and Interest (if any) of Mrs S. Di Clemente (shown on Certificate of Title as Elsa Di Clemente) married woman, of 28 Stortford Avenue, Ivanhoe as joint proprietor with Franco Di Clemente, plasterer, of an estate in fee simple in the land described in Certificate of Title Volume 6825 Folio 899 upon which is erected a dwelling house known as No. 28 Stortford Avenue, Ivanhoe.

Registered Mortgage No. E.501268 affects the said estate and interest.

Terms—Cash only

7388

K. R. MARTIN, Sheriff's Officer

In the Supreme Court of the State of Victoria

#### SALE BY THE SHERIFF

On Thursday 3 July 1980 at 10.30 a.m. at Police Station Footscray (unless process be stayed or satisfied).

All the Estate and Interest (if any) of Archie Stogian-douls (shown on Certificate of Title as Archie Stogg) driver of 98 Roberts Street, West Footscray, as joint



proprietor with Helen Stogg of an estate in fee simple in the land described in Certificate of Title Firstly Volume 6023 Folio 535 upon which is erected a dwelling house known as 73 Roberts Street, West Footscray Secondly Volume 7053 Folio 556 upon which is erected a dwelling house known as 98 Roberts Street, West Footscray Registered Mortgage No. E.606393 and Caveat Nos. H.372632, G.316918 affect the said estate and interest of Volume 6023 Folio 535.

Registered Mortgage No. H.528676 and Caveat No. H.550673 affect the said estate and interest of Volume 7053 Folio 556.

Terms—Cash only  
7389 K. R. MARTIN, Sheriff's Officer

In the Supreme Court of the State of Victoria  
SALE BY THE SHERIFF

On Friday 4 July 1980 at 10.30 a.m. at Police Station Broadmeadows (unless process be stayed or satisfied).

All the Estate and Interest (if any) of Rosario Condello, concreter, and Caterina Condello, married woman, both of 78 Ripplebrook Drive, Broadmeadows as joint proprietors of an estate in fee simple in the land described in Certificate of Title Volume 8979 Folio 436 upon which is erected a brick veneer house known as No. 78 Ripplebrook Drive, Broadmeadows.

Registered Mortgage No. G.727610 Caveat No. H.502586 and the covenant contained in Transfer G.727609 affect the said estate and interest.

Terms—Cash only  
7390 K. R. MARTIN, Sheriff's Officer

In the Supreme Court of the State of Victoria  
SALE BY THE SHERIFF

On Friday 4 July 1980 at 11.30 a.m. at St. Albans Police Station (unless process be stayed or satisfied).

All the Estate and Interest (if any) of Mondo Markovski, press operator (shown on Certificate of Title as Mendo Markovski) of 42 Angelique Grove, St. Albans as joint proprietor with Menka Markovski, machinist, of an estate in fee simple in the land described in Certificate of Title Volume 9186 Folio 234 upon which is erected a brick veneer dwelling known as No. 42 Angelique Grove, St. Albans (lot 8).

Registered Mortgage No. G.900091 affects the said estate and interest.

Terms—Cash only  
7391 K. R. MARTIN, Sheriff's Officer

In the Supreme Court of the State of Victoria  
SALE BY THE SHERIFF

On Thursday 10 July 1980 at 10.30 a.m. at Police Station Broadmeadows (unless process be stayed or satisfied).

All the Estate and Interest (if any) of Kenneth John Cashmore, clerk, of No. 18 Payne Street, Tullamarine, as proprietor of an estate in fee simple in the land described in Certificate of Title Volume 8635 Folio 424 upon which is erected a dwelling house known as No. 18 Payne Street, Tullamarine.

Registered Mortgage No. H.227359 affects the said estate and interest.

Terms—Cash only  
7392 K. R. MARTIN, Sheriff's Officer

**INSOLVENCY NOTICE**

Form 34

Rule 77

THE BANKRUPTCY ACT 1966-73

NOTICE OF MEETING

Bankruptcy District of the State of Victoria

MICHAEL WILLIAM BELL

Take notice that Michael William Bell of 171 Kars Street, Frankston, on 16 May 1980 signed an authority under sub-section (1) of Section 188 of the *Bankruptcy Act 1966* authorising Anthony George Hodgson of 459 Collins Street, Melbourne to call a meeting of his Creditors (and to take over control of his property) and that, in pursuance of Section 194 of the *Bankruptcy Act 1966* a meeting of the Creditors of the abovementioned debtor will be held at the offices of this firm on Tuesday 10 June 1980 at 10.30 a.m.

Dated 19 May 1980  
7342 A. G. HODGSON, Controlling Trustee

**NOTICE OF MAKING OF STATUTORY RULES**

In pursuance of the provisions of the *Subordinate Legislation Act 1962* and the Regulations made thereunder, notice is given of the making of the following Statutory Rules:—

No.	Pay-roll Tax Act 1971	Price
170/1980.	Pay-roll Tax Regulations 1980	30c
Post-Secondary Education Act 1978		
171/1980.	Post-Secondary Education Commission (Terms and Conditions) Regulations 1980	40c

No.	Coroners Act 1958	Price
172/1980.	Coroners (Post-Mortem Fees and Expenses) (Amendment No. 2) Regulations 1980	10c
Police Regulation Act 1958		
173/1980.	Police (Police Reservists) Regulations 1980	10c
Marine Act 1958		
174/1980.	Amendment to Port Rule Applicable to Westernport Harbor Services (Rates and Charges)	10c
Public Service Act 1974		
PSD40/1980.	Public Service Amendment Determinations (No. 40) 1980	50c.
PSD41/1980.	Public Service Amendment Determinations (No. 41) 1980	\$1.00
PSD52/1980.	Public Service Amendment Determinations (No. 52) 1980	10c
PSD53/1980.	Public Service Amendment Determinations (No. 53) 1980	10c
PSD54/1980.	Public Service Amendment Determinations (No. 54) 1980	10c
PSD55/1980.	Public Service Amendment Determinations (No. 55) 1980	10c

Copies of these Statutory Rules when printed may be purchased at the Sale of Publications Branch of the Government Printing Office, located at 7A Parliament Place, Melbourne, 3002. If ordered by mail, remittance should be addressed to "The Government Printer, Box 203, P.O., North Melbourne, 3051", and should include 50c delivery and handling fee.

The annual subscription rates for Statutory Rules for the year commencing 1 January 1980, payable in advance, are as follows:—

*Statutory Rules (other than Public Service Determinations), Pamphlet copies only	\$36.00
Public Service Determinations	\$25.00
* The Bound Volume of Statutory Rules is not included in the subscription rate.	

F. D. ATKINSON  
Government Printer

**STATE ACTS, 1978**

Copies of the following Acts of the Parliament of Victoria may be obtained at the Government Printing Office, Sale of Publications Branch, 7A Parliament Place, Melbourne, phone 651 2754 or 651 2759, or from any accredited agent, at the price set opposite to each.

A delivery and handling fee must be added to your remittance when ordering by mail as follows:—

Total Value of Acts Ordered	Delivery and Handling Fee
10c—\$2.00	0.50c
\$2.05—\$5.00	\$1.00
\$5.05—\$20.00	\$1.50
Above \$20.00	\$2.00

Also available are:—

Bound Volumes	\$21.00
Index to the Bound Volumes	\$9.00

No.	Price
9084. Aerial Spraying Control (Amendment)	\$0.10
9085. Dairy Products (Repeal)	\$0.10
9086. Gas and Fuel Corporation (Borrowing Powers Amendment)	\$0.10
9087. Constitution	\$0.10
9088. Marine (Amendment)	\$0.10
9089. Architects (Professional Conduct)	\$0.10
9090. Victorian Film Corporation (Amendment)	\$0.10
9091. Melbourne and Metropolitan Board of Works (Borrowing Powers Amendment)	\$0.10
9092. Co-operative Farmers and Graziers District Meat Supply Limited	\$0.10
9093. Reference Areas	\$0.10
9094. Molesworth (Land Exchange)	\$0.10
9095. Melbourne Wholesale Fruit and Vegetable Market Trust (Licences)	\$0.10
9096. Public Service (Amendment)	\$0.10
9097. St. Andrew's Hospital	\$0.30
9098. Environment Protection (Amendment)	\$0.30
9099. State Savings Bank (Amendment)	\$0.20
9100. St. Andrew's Hospital (Guarantee)	\$0.10
9101. Education (Amendment)	\$0.10
9102. Land (Amendment)	\$0.10
9103. Probate Duty (Application)	\$0.10
9104. Supply (1978-79, No. 1)	\$0.20
9105. Teaching Service (Appointments)	\$0.10
9106. Fisheries (Amendment)	\$0.20
9107. Road Traffic (Amendment)	\$0.10
9108. Co-operative Housing Societies (Amendment)	\$0.10
9109. Granya (Land Exchange)	\$0.10
9110. Sandringham Land	\$0.10
9111. Vegetation and Vine Diseases (Parasites)	\$0.10
9112. Melbourne Underground Rail Loop (Borrowing Powers)	\$0.10
9113. Railways (Legal Actions)	\$0.10
9114. National Parks (Amendment)	\$0.40
9115. Co-operation (Amendment)	\$0.10
9116. Local Government (Promotion of Decentralization)	\$0.10
9117. Parliamentary Salaries and Superannuation	\$0.10
9118. Country Fire Authority (Borrowing Powers)	\$0.10
9119. Teaching Service (Migrant Instructors)	\$0.10
9120. Stamps (Amendment)	\$0.20
9121. State Electricity Commission (Amendment)	\$0.10
9122. Building Industry Long Service Leave (Amendment)	\$0.10
9123. Melbourne University (Amendment)	\$0.10
9124. Motor Car (Fees and Penalties)	\$0.20
9125. Superannuation (Amendment)	\$0.20
9126. State Development Decentralization and Tourism	\$0.20
9127. Melbourne Harbor Trust (Borrowing Powers)	\$0.10
9128. Cluster Titles (Amendment)	\$0.20
9129. Victoria Conservation Trust	\$0.20
9130. Melbourne and Metropolitan Board of Works (Rate Exemption)	\$0.10
9131. Geelong Waterworks and Sewerage (Administration and Rates)	\$0.10
9132. Mildura Irrigation and Water Trust (Merbein)	\$0.10

STATE ACTS, 1978—continued

No.	Price
9133. Egg Industry Stabilization (Amendment)	\$0.10
9134. Workers Compensation (Special Provisions)	\$0.10
9135. Environment Effects	\$0.10
9136. Workers Compensation (Amendment)	\$0.20
9137. Motor Car (Amendment)	\$0.10
9138. Town and Country Planning (Amendment)	\$0.20
9139. Sewerage Districts (Amendment)	\$0.10
9140. Petroleum Products Subsidy (Amendment)	\$0.10
9141. Water (Amendment)	\$0.10
9142. Railways (Amendment)	\$0.40
9143. Local Government (Regional Refuse Disposal)	\$0.40
9144. Dandenong Valley Authority (Amendment)	\$0.20
9145. Post-Secondary Education	\$0.30
9146. Racing (Amendment)	\$0.10
9147. Physiotherapists	\$0.30
9148. Local Government (Municipal Districts)	\$0.10
9149. Ministry of Transport (Passenger Services)	\$0.20
9150. Geelong Regional Interim Development Order (Validation)	\$0.10
9151. Credit Reporting	\$0.20
9152. Magistrates' Courts (Amendment)	\$0.10
9153. Wrongs (Actions for Damages)	\$0.10
9154. Magistrates (Interstate Enforcement)	\$0.20
9155. Crimes (Hijacking and Other Offences)	\$0.10
9156. Evidence (Amendment)	\$0.10
9157. Motor Car Traders (Amendment)	\$0.20
9158. Bail (Amendment)	\$0.10
9159. Water Drainage	\$0.30
9160. Legal Profession Practice (Solicitors' Disciplinary Tribunal)	\$0.80
9161. Chiropractors and Osteopaths	\$0.50
9162. Local Government (Miscellaneous Provisions)	\$0.60
9163. Hospitals Remuneration Tribunal	\$0.30
9164. Legal Profession Practice (Amendment)	\$0.10
9165. Melbourne and Metropolitan Board of Works (Reconstitution)	\$0.30
9166. Victoria Conservation Trust (Amendment)	\$0.10
9167. Shrine of Remembrance	\$0.20
9168. Pounds (Amendment)	\$0.10
9169. Queenscliff Land	\$0.10
9170. Securities Industry (Amendment)	\$0.10
9171. Labour and Industry	\$0.20
9172. Dandenong Valley Authority (Recreational Areas and Environmental Areas)	\$0.10
9173. Petroleum (Amendment)	\$0.50
9174. Victoria Law Foundation	\$0.20
9175. Mildura Irrigation and Water Trusts (Amendment)	\$0.10
9176. Judges Salaries	\$0.10
9177. Country Roads (Amendment)	\$0.30
9178. Port of Melbourne Authority	\$0.50
9179. Melbourne (Snowden Gardens) Land	\$0.10
9180. Surveyors	\$0.60
9181. State Forests Works and Services	\$0.10
9182. Gas and Fuel Corporation (Municipal Rates)	\$0.10
9183. Land (Amendment)	\$0.20
9184. Road Traffic	\$0.10
9185. Tocumwal Railway Extension (Supplementary Agreement Ratification)	\$0.10
9186. Appropriation (1978-79, No. 1)	\$3.80
9187. Lifts and Cranes (Amusement Structures)	\$0.20
9188. Health Commission (Amendment)	\$0.20
9189. Railways	\$0.10
9190. Land Tax	\$0.20
9191. Country Roads (Borrowing Powers)	\$0.30
9192. Pay-roll Tax	\$0.10
9193. Melbourne and Metropolitan Tramways (Bundoora Tramway)	\$0.10
9194. Melbourne Wholesale Fruit and Vegetable Market Trust (Amendment)	\$0.10
9195. Education (Work Experience for Handicapped Children)	\$0.10
9196. Market Court	\$0.40
9197. Consumer Affairs (Amendment)	\$0.30
9198. Co-ordination Council (Amendment)	\$0.10
9199. Broiler Chicken Industry	\$0.30
9200. Liquor Control	\$0.10
9201. Racing (Amendment)	\$0.40
9202. Legal Profession Practice (Discipline)	\$0.40
9203. Ballarat (Childrens Home)	\$0.20
9204. Trustee (Authorized Investments)	\$0.20
9205. Public Works and Services	\$0.20
9206. Co-operative Housing Societies (Indemnities)	\$0.10

STATE ACTS, 1978—continued		STATE ACTS, 1979—continued	
No.	Price	No.	Price
9207. Environment Protection (Noise Control) ..	\$0.30	9255. Gas and Fuel Corporation (Borrowing Powers) ..	\$0.10
9208. Stamps ..	\$0.20	9256. Ombudsman (Co-operation) ..	\$0.10
9209. Water Supply Works and Services ..	\$0.40	9257. Geelong (Haimes Homes) Land ..	\$0.20
9210. Transport Works and Services ..	\$0.10	9258. Motor Car (Breath Testing Stations) (Amendment) ..	\$0.10
9211. The Constitution Act Amendment (Conduct of Elections) ..	\$0.60	9259. Geelong Waterworks and Sewerage (Trust) ..	\$0.30
9212. Crown Land (Reserves) ..	\$0.80	9260. Bright (Land Exchange) ..	\$0.20
9213. Wine Grape Processing Industry ..	\$0.30	9261. Supply (1979-80, No. 1) ..	\$0.30
9214. Summary Offences (Amendment) ..	\$0.10	9262. Money Lenders (Fees) ..	\$0.10
9215. Workers Compensation (Share Farmers) ..	\$0.10	9263. Exhibition (Amendment) ..	\$0.30
9216. The Constitution Act Amendment (Conjoint Elections) ..	\$0.10	9264. Health (Cattle) ..	\$0.10
9217. Education (Further Amendment) ..	\$0.10	9265. Victorian Public Offices Corporation (Amendment) ..	\$0.10
9218. Country Fire Authority (Borrowing Powers) ..	\$0.10	9266. Community Welfare Services (Amendment) ..	\$0.10
9219. Public Records (Transfer of Administration) ..	\$0.10	9267. Margarine (Amendment) ..	\$0.10
9220. Educational Grants (Continuation) ..	\$0.10	9268. Youth, Sport and Recreation (State Youth Council) ..	\$0.10
9221. Port of Melbourne (World Trade Centre) ..	\$0.10	9269. Racing (Restricted Trotting Meetings) ..	\$0.10
9222. Town and Country Planning (Miscellaneous Provisions) ..	\$0.30	9270. State Electricity Commission (Morwell Land Compensation) ..	\$0.10
9223. Members of Parliament (Register of Interests) ..	\$0.20	9271. Construction Safety ..	\$1.00
9224. Local Government (Rates and Fees) ..	\$0.30	9272. Business Franchise (Petroleum Products) ..	\$0.40
9225. Valuation of Land ..	\$0.20	9273. Albury-Wodonga Agreement (Amendment) ..	\$0.40
9226. Magistrates' Courts (Stipendiary Magistrates) ..	\$0.10	9274. City of Melbourne (Re-subdivision) ..	\$0.10
9227. Charities ..	\$0.20	9275. Co-operation ..	\$0.40
9228. Crimes (Criminal Damage) ..	\$0.30	9276. Cemeteries (Melbourne General Cemetery) ..	\$0.10
9229. Crimes (Offences at Sea) ..	\$0.30	9277. Melbourne and Metropolitan Board of Works (Amendment) ..	\$0.30
9230. Crimes (Competence and Compellability of Spouse Witnesses) ..	\$0.10	9278. River Improvement (Trusts and Valuations) ..	\$0.10
9231. Domicile ..	\$0.10	9279. Instruments (Writs) ..	\$0.10
9232. Dog (Amendment) ..	\$0.20	9280. Forests (Reserved Land) ..	\$0.10
9233. Dental Technicians (Amendment) ..	\$0.10	9281. Trinity College ..	\$0.50
9234. Administrative Law ..	\$0.10	9282. Revocation and Excision of Crown Reservations ..	\$0.30
9235. Melbourne and Metropolitan Board of Works (Miscellaneous Amendments) ..	\$0.20	9283. Local Government (Amendment) ..	\$0.50
9236. Mines (Miscellaneous Provisions) ..	\$0.40	9284. Tattersall Consultations (Amendment) ..	\$0.10
9237. Wheat Industry Stabilization (Amendment) ..	\$0.20	9285. Prahran Market ..	\$0.10
9238. Victorian Dairy Industry Authority (Amendment) ..	\$0.20	9286. Geelong Regional Commission (Amendment) ..	\$0.10
9239. Melbourne and Metropolitan Board of Works (Trade Waste) ..	\$0.10	9287. Pharmacists (Amendment) ..	\$0.10
9240. Trustee Companies (Amendment) ..	\$0.10	9288. Legal Profession Practice (Amendment) ..	\$0.10
9241. Sewerage Districts (Transfer of Works) ..	\$0.10	9289. Barley Marketing (Amendment) ..	\$0.10
9242. Crimes (Amendment) ..	\$0.10	9290. Water Authorities (Constitution and Powers) ..	\$0.20
9243. Motor Car ..	\$0.20	9291. Sewerage Authorities (Constitution and Powers) ..	\$0.30
9244. Health (Amendment) ..	\$0.30	9292. Wrongs (Defamation) ..	\$0.10
9245. Legal Aid Commission ..	\$0.80	9293. Judges Salaries ..	\$0.10
9246. Housing (Amendment) ..	\$0.80	9294. Poisons (Amendment) ..	\$0.10
9247. National Parks ..	\$0.50	9295. Business Franchise (Petroleum Products) (Licence Fees) ..	\$0.20
9248. Community Welfare Services ..	\$0.80	9296. State Electricity Commission (Amendment) ..	\$0.30
9249. Victorian Brown Coal Council ..	\$0.20	9297. Workers Compensation (Miscellaneous Provisions) ..	\$1.00
9250. Police Offences (Offensive Publications) ..	\$0.20	9298. Motor Car (Surcharge) ..	\$0.10
		9299. Unclaimed Moneys ..	\$0.10
		9300. Land Tax ..	\$0.10
		9301. Business Franchise (Tobacco) ..	\$0.10
		9302. Public Authorities (Contributions) ..	\$0.10
		9303. Appropriation (1979-80, No. 1) ..	\$3.50
		9304. Gift Duty (Amendment) ..	\$0.10
		9305. Pay-roll Tax ..	\$0.30
		9306. Transport Works and Services ..	\$0.20
		9307. Melbourne and Metropolitan Tramways (Borrowing Powers) ..	\$0.10
		9308. County Court (Jurisdiction) ..	\$0.10
		9309. State Forests Works and Services ..	\$0.10
		9310. Young Men's Christian Association of Ballarat (Guarantee) ..	\$0.20
		9311. Water Supply Works and Services ..	\$0.40
		9312. Trustee Companies (Trustees Executors) ..	\$0.10
		9313. Commercial Goods Vehicles (Aviation Fuel) ..	\$0.10
		9314. Victorian Development Corporation (Powers) ..	\$0.20
		9315. Town and Country Planning (Planning Schemes) ..	\$1.00
		9316. Victorian Government Travel Authority (Reconstitution) ..	\$0.10
		9317. Stamps (Amendment) ..	\$0.30
		9318. Motor Car (Fees) ..	\$0.30
		9319. Racing (Financial Provisions) ..	\$0.30
		9320. Urban Land Authority ..	\$0.50

### STATE ACTS, 1979

Copies of the following Acts of the Parliament of Victoria may be obtained at the Government Printing Office, Sale of Publications Branch, 7A Parliament Place, Melbourne, phone 651 2754 or 651 2759, or from any accredited agent, at the price set opposite to each.

A delivery and handling fee must be added to your remittance when ordering by mail as follows:—

Total Value of Acts Ordered	Delivery and Handling Fee
10c-\$2.00	0.50c
\$2.05-\$5.00	\$1.00
\$5.05-\$20.00	\$1.50
Above \$20.00	\$2.00

Bound Volumes of 1978 State Acts (\$21.00) and the Index to the Bound Volumes (\$9.00) are also available.

No.	Price
9251. Constitution (Governor's Pension) ..	\$0.10
9252. Joint Select Committee (Road Safety) ..	\$0.20
9253. Cattle Compensation ..	\$0.10
9254. Constitution (Local Government) ..	\$0.30

STATE ACTS, 1979—continued

No.		Price
9321.	Public Works and Services ..	\$0.30
9322.	Second-hand Dealers (Closing Hours) ..	\$0.10
9323.	Crimes (Amendment) ..	\$0.10
9324.	Transfer of Land (Amendment) ..	\$0.40
9325.	Melbourne College of Divinity ..	\$0.30
9326.	Transport Regulation (Car Pools) ..	\$0.10
9327.	Fisheries (Amendment) ..	\$0.10
9328.	Egg Industry Stabilization (Amendment) ..	\$0.10
9329.	Local Authorities Superannuation ..	\$0.30
9330.	Latrobe Valley (Amendment) ..	\$0.10
9331.	Liquor Control (Amendment) ..	\$0.10
9332.	Motor Accidents (Amendment) ..	\$0.40
9333.	Young Farmers' Finance Council ..	\$0.30
9334.	Probate Duty ..	\$0.20
9335.	Railways (Board) ..	\$0.10
9336.	Ministry of Transport (Amendment) ..	\$0.10
9337.	Abattoir and Meat Inspection (Amendment) ..	\$0.20
9338.	Public Service (Amendment) ..	\$0.20
9339.	Trustee Companies (Amendment) ..	\$0.20
9340.	Vermin and Noxious Weeds (Amendment) ..	\$0.30
9341.	Canned Fruits Marketing ..	\$0.40
9342.	Marine (Amendment) ..	\$0.40
9343.	Shire of Ormeo (Tourist Gold Mine) ..	\$0.30
9344.	Presbyterian Trusts ..	\$0.90
9345.	Railway Construction and Property Board ..	\$0.90
9346.	Motor Car (Insurance by Pensioners) ..	\$0.10
9347.	Town and Country Planning (Amendment of Schemes) ..	\$0.10
9348.	Labour and Industry (Amendment) ..	\$0.20
9349.	Magistrates' Courts (Civil Jurisdiction) ..	\$0.40
9350.	Master Builders' Association of Victoria (Guarantee) ..	\$0.20
9351.	Education (Amendment) ..	\$0.20
9352.	Educational Grants (Continuation) ..	\$0.10
9353.	Wrongs (Assessment of Damages) ..	\$0.10
9354.	Victorian Arts Centre ..	\$0.40
9355.	Building Industry Long Service Leave (Amendment) ..	\$0.50
9356.	Local Government (Land Liable to Flooding) ..	\$0.30
9357.	Parliamentary Committees (Public Accounts and Expenditure Review Committee) ..	\$0.20
9358.	Superannuation (Amendment) ..	\$0.30
9359.	Health (Proprietary Medicines) ..	\$0.20
9360.	Victorian Fishing Industry Council ..	\$0.30
9361.	Grain Handling Improvement Authorities ..	\$0.30
9362.	Wheat Marketing ..	\$0.80
9363.	State Employees Retirement Benefits ..	\$1.00
9364.	Town and Country Planning (General Amendment) ..	\$1.00
9365.	Industrial Relations ..	\$1.40

**STATE ACTS, 1980**

Copies of the following Acts of the Parliament of Victoria may be obtained at the Government Printing Office, Sale of Publications Branch, 7A Parliament Place, Melbourne, phone 651 2754 or 651 2759, or from any accredited agent, at the price set opposite to each.

A delivery and handling fee must be added to your remittance when ordering by mail as follows:

Total Value of Acts Ordered	Delivery and Handling Fee
10c—\$2.00	0.50c
\$2.05—\$5.00	\$1.00
\$5.05—\$20.00	\$1.50
Above \$20.00	\$2.00

Bound Volumes of 1978 State Acts (\$21.00) and the Index to the Bound Volumes (\$9.00) are also available.

No.		Price
9366.	Constitutional Powers (Coastal Waters)	20c
9367.	Parliamentary Committees (Public Bodies Review)	40c

ACTS REPRINTED IN ACCORDANCE WITH THE AMENDMENTS INCORPORATION ACT 1958 (No. 6422), AND FOR SALE AS STOCKS ARE AVAILABLE AT THE SALE OF PUBLICATIONS BRANCH OF THE GOVERNMENT PRINTING OFFICE, 7A PARLIAMENT PLACE, MELBOURNE, 3002.

A delivery and handling fee must be added to your remittance when ordering by mail as follows:—

Total Value of Acts Ordered	Delivery and Handling Fee
10c—\$2.00	0.50c
\$2.05—\$5.00	\$1.00
\$5.05—\$20.00	\$1.50
Above \$20.00	\$2.00

No.		Price
8404.	Abattoir and Meat Inspector (First Reprint—Incorporating amendments up to No. 9005)	\$0.85
6189.	Acts Interpretation (Fifth Reprint—Incorporating amendments up to Act No. 9229)	\$0.70
6191.	Administration and Probate Act 1958 (Fifth Reprint—Incorporating amendments up to No. 9075)	\$1.05
7147.	Adoption of Children (First Reprint—Incorporating amendments up to Act No. 8602)	\$0.75
6194.	Agricultural Colleges (First Reprint—Incorporating amendments up to No. 7302)	\$0.15
7772.	Alcoholic and Drug-Dependent Persons Act 1968 (First Reprint—Incorporating amendments up to Act No. 9023)	\$0.60
6198.	Anzac Day (First Reprint—Incorporating amendments up to No. 8344)	\$0.15
7117.	Appeal Costs Fund Act 1964 (Second Reprint—Incorporating amendments up to No. 8145)	\$0.35
8273.	Archaeological and Aboriginal Preservation Act 1972 (First Reprint—Incorporating amendments up to Act No. 9019)	\$0.30
6201.	Architects (First Reprint—Incorporating amendments up to No. 8077)	\$0.30
6202.	Auction Sales (First Reprint—Incorporating amendments up to No. 8490)	\$0.35
6203.	Audit (First Reprint—Incorporating amendments up to No. 7377)	\$0.35
9008.	Bail Act 1977 (First Reprint—Incorporating amendments up to Act No. 9158)	\$0.70
6206.	Barley Marketing (First Reprint—Incorporating amendments up to No. 9005)	\$0.30
6208.	Benefit Associations (First Reprint—Incorporating amendments up to No. 6961)	\$0.65
8004.	Boilers and Pressure Vessels Act 1970—(Second Reprint—Incorporating amendments up to Act No. 9019)	\$0.65
6529.	Bread Industry Act 1959 (Second Reprint—Incorporating amendments up to Act No. 8542)	\$0.20
6973.	Building Contracts (Deposits) Act 1962 (Second Reprint—Incorporating amendments from No. 8938)	\$0.20
8693.	Building Industry Long Service Leave (First Reprint—Incorporating Amendments up to No. 9122)	\$0.85
6213.	Cancer Act 1958 (Second Reprint—Incorporating amendments up to No. 9023)	\$1.10
6214.	Carriers and Innkeepers (Second Reprint—Incorporating amendments up to No. 8534)	\$0.20
6215.	Cattle Breeding (First Reprint—Incorporating amendments up to No. 6886)	\$0.10
6217.	Cemeteries Act 1958 (Second Reprint—Incorporating amendments up to Act No. 9052)	\$0.90
8477.	Children's Court Act 1973 (First Reprint—Incorporating amendments up to No. 8731)	\$0.95
6220.	Clean Air (Third Reprint—Incorporating amendments up to No. 8324)	\$0.15
4597.	Closer Settlement Act (First Reprint—Incorporating amendments up to Act No. 9212)	\$1.20
8661.	Cluster Titles Act 1974 (First Reprint—Incorporating amendments up to Act No. 9128)	\$0.85
6221.	Coal Mines (Second Reprint—Incorporating amendments up to No. 8953)	\$2.15
6222.	Commercial Goods Vehicles (Third Reprint—Incorporating amendments up to No. 8525)	\$0.55

ACTS REPRINTED IN ACCORDANCE WITH THE AMENDMENTS  
INCORPORATION ACT 1958 (No. 6422)—*continued*

No.	Price
6223. Commonwealth Arrangements ( <i>First Reprint</i> —Incorporating amendments from No. 7809) ..	\$0.10
6839. Companies ( <i>Sixth Reprint</i> —Incorporating amendments up to No. 8788) ..	\$9.60
8750. Constitution Act 1975 ( <i>Third Reprint</i> —Incorporating amendments up to Act No. 9251) ..	\$1.30
6224. Constitution Act Amendment Act 1959 ( <i>Second Reprint</i> —Incorporating amendment up to No. 9216) ..	\$3.00
8276. Consumer Affairs Act 1972 ( <i>Third Reprint</i> —Incorporating amendments up to No. 8824) ..	\$1.15
6225. Co-operation Act 1958 ( <i>Fourth Reprint</i> —Incorporating amendments up to Act No. 9136) ..	\$1.60
6226. Co-operative Housing Societies Act 1958 ( <i>Third Reprint</i> —Incorporating amendments up to No. 9206) ..	\$1.50
6227. Coroners ( <i>Second Reprint</i> —Incorporating amendments up to No. 8184) ..	\$0.35
6228. Country Fire Authority ( <i>Third Reprint</i> —Incorporating amendments up to No. 8813) ..	\$1.25
6229. Country Roads Act 1958 ( <i>Fifth Reprint</i> —Incorporating amendments up to No. 9212) ..	\$2.00
6230. County Court ( <i>Fourth Reprint</i> —Incorporating amendments up to No. 9075) ..	\$0.95
6231. Crimes Act 1958 ( <i>Sixth Reprint</i> —Incorporating amendments up to Act No. 9073) ..	\$3.15
6232. Crown Proceedings ( <i>Second Reprint</i> —Incorporating amendments up to No. 8731) ..	\$0.40
7060. Dandenong Valley Authority Act 1963 ( <i>Second Reprint</i> —Incorporating amendments up to Act No. 9172) ..	\$1.20
8383. Decentralized Industry Incentive Payments ( <i>First Reprint</i> —Incorporating Amendments up to No. 8751) ..	\$0.20
6235. Dietitians Registration ( <i>First Reprint</i> —Incorporating amendments up to No. 6886) ..	\$0.20
4989. Discharged Servicemen's Preference Act 1943 ( <i>Second Reprint</i> —Incorporating amendments up to No. 7991) ..	\$0.20
6815. Disposal of Uncollected Goods Act 1961 ( <i>Second Reprint</i> —Incorporating amendments up to No. 8246) ..	\$0.30
8079. Dog Act 1970 ( <i>First Reprint</i> —Incorporating amendments up to No. 8654) ..	\$0.30
6237. Drainage Areas Act 1958 ( <i>Second Reprint</i> —Incorporating amendments up to Act No. 8811) ..	\$0.75
6239. Dried Fruits Act 1968 ( <i>First Reprint</i> —Incorporating amendments up to No. 7337) ..	\$0.25
6240. Education Act 1958 ( <i>Third Reprint</i> —Incorporating amendments up to Act No. 9248) ..	\$1.50
6241. Electric Light and Power ( <i>First Reprint</i> —Incorporating amendments up to No. 7315) ..	\$0.30
8056. Environment Protection Act 1970 ( <i>Third Reprint</i> —Incorporating amendments up to Act No. 9098) ..	\$0.95
6244. Essential Services ( <i>First Reprint</i> —Incorporating amendments up to No. 8353) ..	\$0.20
6245. Estate Agents—( <i>Fifth Reprint</i> —Incorporating amendments up to No. 8490) ..	\$0.85
6246. Evidence Act 1958 ( <i>Sixth Reprint</i> —Incorporating amendments up to Act No. 9230) ..	\$1.60
6715. Explosives Act 1960 ( <i>First Reprint</i> —Incorporating amendments up to Act No. 8920) ..	\$0.85
7499. Extractive Industries Act 1966 ( <i>Third Reprint</i> —Incorporating amendments up to No. 8647) ..	\$0.45
7733. Fences Act 1968 ( <i>Second Reprint</i> —Incorporating amendments up to Act No. 9019) ..	\$0.70
6468. Filled Milk ( <i>First Reprint</i> —Incorporating amendments up to No. 6886) ..	\$0.15
6251. Firearms ( <i>Fifth Reprint</i> —Incorporating amendments up to No. 8427) ..	\$1.05
7780. Fisheries Act 1968 ( <i>First Reprint</i> —Incorporating amendments up to No. 8694) ..	\$1.05
6916. Foreign Judgments Act 1962 ( <i>First Reprint</i> including amendments made by No. 7332) ..	\$0.15

ACTS REPRINTED IN ACCORDANCE WITH THE AMENDMENTS  
INCORPORATION ACT 1958 (No. 6422)—*continued*

No.	Price
6585. Forests (Pulpwood Agreement) (Incorporating amendments up to No. 6886) ..	\$0.15
6254. Forests ( <i>Second Reprint</i> —Incorporating amendments up to No. 8702) ..	\$1.35
6225. Friendly Societies Act 1958 ( <i>Second Reprint</i> —Incorporating amendments up to Act No. 9019) ..	\$1.60
6255. Friendly Societies ( <i>First Reprint</i> —Incorporating amendments up to No. 7554) ..	\$0.60
6256. Fruit and Vegetables ( <i>First Reprint</i> —Incorporating amendments up to No. 6944) ..	\$0.30
6260. Gas and Fuel Corporation Act 1958 ( <i>Second Reprint</i> —Incorporating amendments up to Act No. 9255) ..	\$2.40
6262. Geelong Harbor Trust Act 1958 ( <i>Second Reprint</i> —Incorporating amendments up to Act No. 9019) ..	\$1.40
6263. Geelong Waterworks and Sewerage ( <i>First Reprint</i> —Incorporating amendments up to No. 7547) ..	\$0.75
8176. Gift Duty Act 1971 ( <i>First Reprint</i> —Incorporating amendments from No. 8202) ..	\$0.55
6265. Goods ( <i>Sixth Reprint</i> —Incorporating amendments up to No. 8425) ..	\$0.75
6266. Grain Elevators ( <i>First Reprint</i> —Incorporating amendments up to No. 7486) ..	\$0.35
7849. Groundwater ( <i>Second Reprint</i> —Incorporating amendments up to No. 9019) ..	\$0.75
6267. Hairdressers Registration ( <i>First Reprint</i> —Incorporating amendments up to No. 7659) ..	\$0.30
6269. Hawkers and Pedlars ( <i>Second Reprint</i> —Incorporating amendments up to No. 8247) ..	\$0.40
6270. Health ( <i>Third Reprint</i> —Incorporating amendments up to No. 8506) ..	\$3.25
6531. Hire Purchase Act 1959 ( <i>Second Reprint</i> —Incorporating amendments from No. 8232) ..	\$0.85
6933. Home Finance Act 1962 ( <i>First Reprint</i> —Incorporating amendments up to No. 7363) ..	\$0.25
6274. Hospitals and Charities ( <i>Second Reprint</i> —Incorporating amendments up to No. 7455) ..	\$0.50
6275. Housing ( <i>Third Reprint</i> —Incorporating amendments up to No. 8713) ..	\$2.40
3270. Imperial Acts Application ( <i>First Reprint</i> —Incorporating Amendments up to No. 8037) ..	\$1.30
6276. Imprisonment of Fraudulent Debtors ( <i>Second Reprint</i> —Incorporating amendments up to No. 8731) ..	\$0.55
6277. Industrial and Provident Societies ( <i>First Reprint</i> —Incorporating amendments up to No. 7547) ..	\$1.10
6279. Instruments ( <i>Fifth Reprint</i> —Incorporating amendments up to No. 8565) ..	\$0.75
6280. Judicial Proceedings Reports ( <i>First Reprint</i> —Incorporating amendments up to No. 7596) ..	\$0.20
7651. Juries ( <i>First Reprint</i> —Incorporating amendments up to No. 8170) ..	\$0.55
6283. Labour and Industry Act 1958 ( <i>Seventh Reprint</i> —Incorporating amendments up to Act No. 9163) ..	\$1.90
6284. Land Act ( <i>Fourth Reprint</i> —Incorporating amendments up to No. 9212) ..	\$4.40
6534. Land Settlement Act 1959 ( <i>First Reprint</i> —Incorporating amendments up to No. 7328) ..	\$0.30
6288. Land Surveyors ( <i>First Reprint</i> —Incorporating amendments up to No. 7065) ..	\$0.30
6289. Land Tax Act 1958 ( <i>Third Reprint</i> —Incorporating amendments to Act No. 9190) ..	\$1.40
6285. Landlord and Tenant ( <i>Fourth Reprint</i> —Incorporating amendments up to No. 8208) ..	\$1.90
6286. Lands Compensation Act ( <i>Third Reprint</i> —Incorporating amendments up to No. 8899) ..	\$0.45
6290. Latrobe Valley ( <i>First Reprint</i> —Incorporating amendments up to No. 7332) ..	\$0.35
7919. Legal Aid—( <i>First Reprint</i> —Incorporating amendments up to No. 8427) ..	\$0.30
6291. Legal Profession Practice Act ( <i>Fourth Reprint</i> —Incorporating amendments up to No. 8778) ..	\$1.45
6292. Libraries ( <i>First Reprint</i> —Incorporating amendments up to No. 7364) ..	\$0.15

ACTS REPRINTED IN ACCORDANCE WITH THE AMENDMENTS  
INCORPORATION ACT 1958 (No. 6422)—*continued*

No.	Price
7629. Lifts and Cranes Act 1967 ( <i>Second Reprint</i> —Incorporating amendments up to Act No. 9236)	\$0.90
6295. Limitation of Actions ( <i>Third Reprint</i> —Incorporating amendments up to No. 8300)	\$0.55
7695. Liquor Control Act 1968 ( <i>Third Reprint</i> —Incorporating amendments up to No. 8598)	\$1.70
7145. Litter Act 1964 ( <i>Second Reprint</i> —Incorporating amendments up to No. 8702)	\$0.20
6298. Local Authorities Superannuation ( <i>Second Reprint</i> —Incorporating amendments up to No. 7161)	\$0.40
6479. Local Government Department Act 1958 ( <i>First Reprint</i> —Incorporating amendments up to Act No. 8656)	\$0.10
6299. Local Government ( <i>Third Reprint</i> —Incorporating amendments up to No. 8781)	\$10.90
7429. Lotteries Gaming and Betting Act 1966 ( <i>Second Reprint</i> —Incorporating amendments up to No. 9075)	\$1.20
8184. Magistrates' Courts ( <i>First Reprint</i> —Incorporating amendments up to No. 8718)	\$0.75
7289. Maintenance ( <i>Second Reprint</i> —Incorporating amendments up to No. 9019)	\$1.35
6302. Marine Act ( <i>Second Reprint</i> —Incorporating amendments up to No. 9178)	\$2.40
6303. Marine Stores and Old Metals Act 1958 ( <i>Second Reprint</i> —Incorporating amendments up to Act No. 8622)	\$0.65
6304. Marketing of Primary Products ( <i>First Reprint</i> —Incorporating amendments up to No. 7491)	\$0.45
6305. Markets Act ( <i>Second Reprint</i> —Incorporating amendments up to No. 8247)	\$0.30
6306. Marriage ( <i>Second Reprint</i> —Incorporating amendments up to No. 8602)	\$0.45
6309. Medical Act 1958 ( <i>Third Reprint</i> —Incorporating amendments up to No. 8593)	\$0.45
8061. Medical Practitioner ( <i>First Reprint</i> —Incorporating amendments up to No. 8754)	\$0.75
6310. Melbourne and Metropolitan Board of Works ( <i>Fourth Reprint</i> —Incorporating amendments up to No. 8650)	\$1.95
6311. Melbourne and Metropolitan Tramways Act 1958 ( <i>Second Reprint</i> —Incorporating amendments up to Act No. 8992)	\$1.45
6312. Melbourne Harbor Trust ( <i>Second Reprint</i> —Incorporating amendments up to No. 8796)	\$1.35
6405. Melbourne University Act 1958 ( <i>Second Reprint</i> —Incorporating amendments up to Act No. 9123)	\$0.85
6605. Mental Health ( <i>Second Reprint</i> —Incorporating amendments up to No. 8679)	\$0.75
6315. Metropolitan Fire Brigades ( <i>Third Reprint</i> —Incorporating amendments up to No. 9019)	\$0.95
6316. Mildura Irrigation and Water Trusts Act 1958 ( <i>Second Reprint</i> —Incorporating amendments up to No. 9204)	\$2.60
6317. Milk and Dairy Supervision ( <i>Second Reprint</i> —Incorporating amendments up to No. 8655)	\$0.85
6318. Milk Board Act 1958 ( <i>Second Reprint</i> —Incorporating amendments up to Act No. 9238)	\$1.00
6319. Milk Pasteurization ( <i>First Reprint</i> —Incorporating amendments up to No. 7480)	\$0.20
6320. Mines Act 1958 ( <i>Third Reprint</i> —Incorporating amendments up to Act No. 8953)	\$2.60
6184. Monash University ( <i>First Reprint</i> —Incorporating amendments up to No. 7533)	\$0.30
6324. Money Lenders ( <i>Fourth Reprint</i> —Incorporating amendments up to No. 8490)	\$0.55
8429. Motor Accidents Act 1973 ( <i>First Reprint</i> —Incorporating amendment up to No. 8669)	\$1.15
6832. Motor Boating Act 1961 ( <i>Third Reprint</i> —Incorporating amendment up to No. 8662)	\$0.55
6325. Motor Car Act 1958 ( <i>Fifth Reprint</i> —Incorporating amendments up to No. 8657)	\$2.25
6705. Navigable Waters (Oil Pollution) Act 1960 ( <i>Second Reprint</i> —Incorporating amendments up to No. 8816)	\$0.65

ACTS REPRINTED IN ACCORDANCE WITH THE AMENDMENTS  
INCORPORATION ACT 1958 (No. 6422)—*continued*

No.	Price
6328. Nurses Act 1958 ( <i>Fourth Reprint</i> —Incorporating amendments up to Act No. 9059)	\$1.00
8414. Ombudsman Act 1973 ( <i>Second Reprint</i> —Incorporating amendments up to Act No. 9256)	\$0.60
6329. Optometrists Registration Act 1958 ( <i>Second Reprint</i> —Incorporating amendments up to Act No. 8800)	\$0.70
7723. Parliamentary Salaries and Superannuation ( <i>First Reprint</i> —Incorporating amendments up to No. 8687)	\$0.35
6330. Partnership ( <i>Second Reprint</i> —Incorporating amendments up to No. 7315)	\$0.45
6331. Patriotic Funds ( <i>First Reprint</i> —Incorporating amendments up to No. 7338)	\$0.25
6332. Pawnbrokers Act 1958 ( <i>Second Reprint</i> —Incorporating amendments up to No. 8181)	\$0.35
8154. Pay-Roll Tax Act 1971 ( <i>First Reprint</i> —Incorporating amendments up to No. 9059)	\$1.15
7417. Pensions Supplementation ( <i>First Reprint</i> —Incorporating amendments up to No. 8475)	\$0.20
6257. Pesticides Act 1958 ( <i>Second Reprint</i> —Incorporating amendments up to No. 8589)	\$0.35
6334. Petroleum Act 1958 ( <i>Second Reprint</i> —Incorporating amendments up to Act No. 9212)	\$1.30
6335. Petrol Pumps ( <i>Second Reprint</i> —Incorporating amendments up to No. 7315)	\$0.15
6889. Poisons Act 1962 ( <i>Fourth Reprint</i> —Incorporating amendments up to No. 8456)	\$0.95
6337. Police Offences Act 1958 ( <i>Third Reprint</i> —Incorporating amendments up to No. 8433)	\$0.45
6338. Police Regulation ( <i>Third Reprint</i> —Incorporating amendments up to No. 8722)	\$0.95
6340. Portland Harbor Trust Act 1958 ( <i>Second Reprint</i> —Incorporating amendments up to Act No. 9204)	\$1.10
7498. Port Phillip Authority Act 1966 ( <i>Second Reprint</i> —Incorporating amendments from No. 8081)	\$0.20
6341. Pounds Act 1958 ( <i>Second Reprint</i> —Incorporating amendments up to Act No. 9168)	\$0.60
6342. Printers and Newspapers ( <i>Second Reprint</i> —Incorporating amendments up to No. 8556)	\$0.30
7494. Private Agents Act 1966 ( <i>Third Reprint</i> —Incorporating amendments up to Act No. 9075)	\$1.00
6890. Probate Duty Act 1962. ( <i>Fourth Reprint</i> )—Incorporating amendments up to Act No. 9019	\$1.15
6344. Property Law Act 1958 ( <i>Fourth Reprint</i> —Incorporating amendments up to Act No. 9075)	\$3.00
7432. Protection of Animals ( <i>First Reprint</i> —Incorporating Amendments Up to No. 9019)	\$0.40
6345. Public Account ( <i>Second Reprint</i> —Incorporating amendments up to No. 9033)	\$0.40
6346. Public Authorities Marks ( <i>First Reprint</i> —Incorporating amendments from No. 7315)	\$0.10
8656. Public Service Act 1974 ( <i>Second Reprint</i> —Incorporating amendments up to Act No. 9248)	\$1.40
6350. Public Trustee Act 1958 ( <i>Second Reprint</i> —Incorporating amendments up to No. 8125)	\$1.05
6353. Racing ( <i>Fourth Reprint</i> —Incorporating amendments up to No. 8690)	\$1.55
6355. Railways Act 1958 ( <i>Second Reprint</i> —Incorporating amendments up to Act No. 9142)	\$1.55
6564. Registration of Births Deaths and Marriages Act 1959 ( <i>Second Reprint</i> —Incorporating amendments up to Act No. 8602)	\$0.70
6357. Religious Successory and Charitable Trusts Act 1958 ( <i>First Reprint</i> —Incorporating amendments made by Act No. 7315)	\$0.75
6358. River Improvements Act ( <i>Second Reprint</i> —Incorporating amendments up to No. 8967)	\$0.85

ACTS REPRINTED IN ACCORDANCE WITH THE AMENDMENTS  
INCORPORATING ACT 1958 (No. 6422)—*continued*

No.	Price
2596. River Murray Waters Act 1915 ( <i>First Reprint</i> —Incorporating amendments up to No. 7228)	\$0.35
6359. Road Traffic ( <i>Fourth Reprint</i> —Incorporating amendments up to No. 8353)	\$0.35
6360. Rural Finance ( <i>First Reprint</i> —Incorporating amendments up to No. 7328)	\$0.15
6846. Rural Finance and Settlement Commission Act 1961 ( <i>First Reprint</i> —Incorporating amendments up to No. 7332)	\$0.30
6917. Sale of Human Blood Act 1962 ( <i>First Reprint</i> —Incorporating amendments from No. 7332)	\$0.10
6975. Sale of Land Act 1962 ( <i>Third Reprint</i> —Incorporating amendments up to No. 8861)	\$0.55
8146. Scaffolding Act 1971 ( <i>Second Reprint</i> —Incorporating amendments up to No. 8666)	\$0.35
6363. Second-hand Dealers ( <i>First Reprint</i> —Incorporating amendments up to No. 7529)	\$0.25
6367. Settled Land Act 1958 ( <i>Third Reprint</i> —Incorporating amendments up to Act No. 9075)	\$1.50
6368. Sewerage Districts Act 1958 ( <i>Third Reprint</i> —Incorporating amendments up to Act No. 9139)	\$1.90
6809. Sheep Owners Protection Act 1961 ( <i>Third Reprint</i> —Incorporating amendments up to No. 8247)	\$0.20
8089. Social Welfare Act 1970 ( <i>First Reprint</i> —Incorporating amendments up to No. 8821)	\$1.90
6372. Soil Conservation and Land Utilization Act ( <i>Third Reprint</i> —Incorporating amendments up to No. 8432)	\$0.45
6373. Soldier Settlement ( <i>First Reprint</i> —Incorporating amendments up to No. 7328)	\$0.42
6375. Stamps Act 1958 ( <i>Sixth Reprint</i> —Incorporating amendments up to No. 8624)	\$2.15
6376. State Development Committee Act 1958 ( <i>First Reprint</i> —Incorporating amendments up to No. 8827)	\$0.30
6377. State Electricity Commission Act 1958 ( <i>Third Reprint</i> —Incorporating amendments up to Act No. 9121)	\$1.35
6378. State Relief Committee ( <i>First Reprint</i> —Incorporating amendments from No. 6886)	\$0.10
6379. State Savings Bank Act 1958 ( <i>Third Reprint</i> —Incorporating amendments up to No. 8519)	\$0.95
6380. Statistics ( <i>First Reprint</i> —Incorporating amendments up to No. 6961)	\$0.20
6877. Stock (Artificial Breeding) Act 1962 ( <i>First Reprint</i> —Incorporating amendments up to No. 8709)	\$0.30
6383. Stock Foods ( <i>First Reprint</i> —Incorporating amendments up to No. 7607)	\$0.28
6384. Stock Medicines Act 1958 ( <i>Second Reprint</i> —Incorporating amendments up to No. 9005)	\$0.50
7551. Strata Titles Act 1967 ( <i>Third Reprint</i> —Incorporating amendments up to No. 8661)	\$1.00
6886. Subordinate Legislation Act 1962 ( <i>Second Reprint</i> —Incorporating amendments up to No. 8127)	\$0.15
7405. Summary Offences Act 1966 ( <i>Second Reprint</i> —Incorporating amendments up to No. 8276)	\$0.55
7634. Sunday Entertainment ( <i>First Reprint</i> —Incorporating amendments up to No. 8173)	\$0.15
6386. Superannuation Act 1958 ( <i>Fourth Reprint</i> —Incorporating amendments up to No. 9125)	\$1.70
6387. Supreme Court ( <i>Second Reprint</i> —Incorporating amendments up to No. 8951)	\$1.35
6388. Survey Co-ordination ( <i>First Reprint</i> —Incorporating amendments up to No. 8107)	\$0.35
6390. Tattersall Consultations ( <i>Second Reprint</i> —Incorporating amendments up to No. 8982)	\$0.30
8274. Taxation Appeals Act 1972 ( <i>First Reprint</i> —Incorporating amendments up to Act No. 9045)	\$0.55

ACTS REPRINTED IN ACCORDANCE WITH THE AMENDMENTS  
INCORPORATION ACT 1958 (No. 6422)—*continued*

No.	Price
6391. Teaching Service ( <i>Second Reprint</i> —Incorporating amendments up to No. 8691)	\$0.55
6393. Theatres ( <i>First Reprint</i> —Incorporating amendments up to No. 8161)	\$0.15
6849. Town and Country Planning Act 1961 ( <i>Fifth Reprint</i> —Incorporating amendments up to No. 8716)	\$1.25
6397. Trade Unions ( <i>Second Reprint</i> —Incorporating amendments up to No. 8181)	\$0.20
6399. Transfer of Land ( <i>Fifth Reprint</i> —Incorporating amendments up to No. 8531)	\$1.15
6400. Transport Regulation Act ( <i>Third Reprint</i> —Incorporating amendments up to No. 8700)	\$0.75
6401. Trustee Act 1958 ( <i>Fourth Reprint</i> —Incorporating amendments up to Act No. 9075)	\$1.15
6402. Trustee Companies Act 1958 ( <i>Second Reprint</i> —Incorporating amendments up to Act No. 9075)	\$0.55
6879. Unclaimed Moneys Act 1962 ( <i>Second Reprint</i> —Incorporating amendments up to No. 8448)	\$0.20
7095. Underseas Mineral Resources Act 1963 ( <i>First Reprint</i> —Incorporating amendments from No. 7591)	\$0.10
6653. Valuation of Land Act 1960 ( <i>Fifth Reprint</i> —Incorporating amendments up to Act No. 9225)	\$1.10
6407. Vegetation and Vine Diseases ( <i>First Reprint</i> —Incorporating amendments up to No. 7423)	\$0.30
6408. Venereal Diseases ( <i>First Reprint</i> —Incorporating amendments made by Act No. 6886)	\$0.55
6409. Vermin & Noxious Weeds ( <i>First Reprint</i> —Incorporating amendments up to No. 7463)	\$0.35
6410. Veterinary Surgeons ( <i>First Reprint</i> —Incorporating amendments up to No. 7343)	\$0.15
7291. Victoria Institute of Colleges Act 1965 ( <i>Second Reprint</i> —Incorporating amendments up to No. 8710)	\$0.65
6412. Warehousemen's Liens ( <i>First Reprint</i> —Incorporating amendments up to No. 7876)	\$0.15
6413. Water ( <i>Third Reprint</i> —Incorporating amendments up to No. 8729)	\$3.45
6414. Weights and Measures Act 1958 ( <i>Fourth Reprint</i> —Incorporating amendments up to Act No. 9019)	\$1.90
6415. Wild Flowers and Native Plants Protection ( <i>First Reprint</i> —Incorporating amendments up to No. 6976)	\$0.15
6416. Wills Act 1958 ( <i>Second Reprint</i> —Incorporating amendments up to Act No. 9075)	\$0.60
6417. Wire Netting ( <i>Second Reprint</i> —Incorporating amendments up to No. 7876)	\$0.65
6419. Workers Compensation Act ( <i>Seventh Reprint</i> —Incorporating amendments up to No. 8804)	\$1.45
6420. Wrongs Act 1958. ( <i>Third Reprint</i> —Incorporating amendments up to Act No. 9153)	\$0.60
8344. Youth, Sport and Recreation Act 1972 ( <i>First Reprint</i> —Incorporating amendments up to No. 8550)	\$0.35

## NOTIFICATION OF FIRST REPRINT

No.	PRICE
4597. Closer Settlement Act 1980 ( <i>First Reprint</i> —Incorporating amendments up to Act No. 9212)	\$1.20
6277. Industrial and Provident Societies Act 1958 ( <i>First Reprint</i> —Incorporating amendments up to Act No. 7547)	\$1.10
8428. Victorian Development Corporation Act 1973 ( <i>First Reprint</i> —Incorporating amendments up to Act No. 9314)	\$1.00

F. D. ATKINSON  
Government Printer

## THE "VICTORIA GOVERNMENT GAZETTE"

PUBLICATION—A VICTORIA GOVERNMENT GAZETTE is published every WEDNESDAY EVENING unless advertised otherwise.

SUBSCRIPTIONS—The Subscription, including postage, is \$62 per annum, or \$31 per half year, payable in advance. Subscriptions are required for whole months, but must cover at least a half-year.

PRIVATE ADVERTISEMENTS—Advertisements will be received by the Government Printer not later than the day preceding publication—at ordinary rates at or before ONE p.m. and at double rates between ONE p.m. and HALF PAST THREE p.m. The charge for ADVERTISEMENTS is 78 cents per line single column and \$1.56 per line double column. The charge for a full page is \$118. The title forms one or more lines as a heading. On an average ten words make a line of single column. Every signature must likewise be counted as a line. The final words of a paragraph though only portion of a line, must be counted as one line. Signatures (in particular) and proper names must be written very clearly in the text: ONE SIDE ONLY of each sheet of paper should be written upon.

All documents NOT CLEARLY PREPARED will be returned unpublished. Where brands occur, not provided for by the ordinary letters of the alphabet, a written explanatory description also must be furnished.

PAYMENTS—Unless the advertiser has a Credit Account, all payments are required in advance. Remittances should be made by cheque, postal order or money order, payable to "GOVERNMENT PRINTER".

CORRESPONDENCE—All correspondence should be addressed to "The Victorian Government Printer, P.O. Box 203, North Melbourne, 3051".

## AGENTS FOR THE "VICTORIA GOVERNMENT GAZETTE"

The following have been appointed agents to receive Advertisements and Subscriptions for the Victoria Government Gazette:—

ARMSTRONG'S AGENCY, 217 Queen Street, Melbourne, Victoria 3000.  
 ARNALL & JACKSON, 390 Barkly Street, Brunswick, Victoria 3056  
 BAIRNSDALE AUTHORIZED NEWSAGENCY, 132 Main Street, Bairnsdale, Victoria 3875.  
 BENALLA AUTHORIZED NEWSAGENCY, 45 Bridge Street, Benalla, Victoria 3672.  
 BLANE'S AUTHORIZED NEWSAGENTS, 162 Murray Street, Colac, Victoria 3250.  
 CARTER, R. G., ADVERTISING SERVICE PTY. LTD., 129 Church Street, Hawthorn, Victoria 3122.  
 CORNELL, R. G., 126 Eighth Street, Mildura.  
 FAROE, S. W. & E. P., 79 Henty Street, Casterton, Victoria 3311.  
 FRANKS, H., & CO., 184 Ryrie Street, Geelong, Victoria 3220.  
 GORDON & GOTCH AUSTRALASIA LTD., 25-37 Huntingdale Road, Burwood, Victoria 3125.  
 HARSTON, PARTRIDGE & CO. PTY. LTD., 455 Little Collins Street, Melbourne, Victoria 3000.  
 KYNETON GUARDIAN PTY. LTD., P.O. Box 18, Kyneton, Victoria 3444.  
 LONSDALE NEWSAGENCY, 250 Lonsdale Street, Dandenong, Victoria 3175.  
 LOVELL'S SHEPPARTON NEWSAGENCY, 246 Wyndham Street, Shepparton, Victoria 3630.  
 THE MERCANTILE EXCHANGE, 15 Queen Street, Melbourne, Victoria 3000.  
 McDONALD'S NEWSAGENCY, 88 Bridge Street, Ballarat, Victoria 3350.

McGILL'S AUTHORIZED NEWSAGENCY, 183-5 Elizabeth Street, Melbourne, Victoria 3000.

McNAUGHTON, P. R. & L. A., 112-114 Gray Street, Hamilton, Victoria 3300.

POWNEY'S AUTHORIZED NEWSAGENCY, 293 Hargreaves Street, Bendigo, Victoria 3550.

PURDIE, J., & CO., 138 Moorabool Street, Geelong, Victoria 3220.

SALE AUTHORIZED NEWSAGENCY 292-294 Raymond Street, Sale, Victoria 3850.

VERNONS OF RICHMOND, 261 Bridge Road, Richmond, Victoria 3121.

VIEW POINT AUTHORIZED NEWSAGENCY, 4 View-Point, Bendigo, Victoria 3550.

## CONTENTS

	Page
Acts of Parliament	1657
Acts of Parliament on Sale at the Government Printing Office	1746
Appointments	1682
Cemeteries—Scale of Fees	1671
Companies Act 1961—Notice	1662
Contracts	1675
Estates of Deceased Persons	1662
Government Notices	1659
Insolvency Notice	1745
Lands	1700
Melbourne and Metropolitan Board of Works—Notice	1673
Minerals and Energy	1677
Notice to Mariners	1674
Notice of Making of Statutory Rules	1745
Orders in Council—	
Acts—Local Government; Country Roads Board; Marine; Crown Land (Reserves); Land; Patriotic Funds; Victoria Law Foundation; Melbourne and Metropolitan Tramways; Water; Mildura Irrigation and Water Trusts; Sewerage Districts; Superannuation; Water; Sewerage Districts; Public Service.	1683 et seq
Private Advertisements	1702
Proclamations	1657
Public Holiday—Queen's Birthday	1659
Resignations	1683
State Rivers and Water Supply Commission	1669
Tenders	1701
Transport Regulation Board—Public Hearings	1663
Waterworks Trust	1671