



# Victoria Government Gazette

No. 84—Wednesday, 1 October 1980

## PROCLAMATIONS

### ACTS OF PARLIAMENT

#### PROCLAMATION

By His Excellency the Governor of the State of Victoria and its Dependencies in the Commonwealth of Australia, &c., &c., &c.

I, the Governor of the State of Victoria, in the Commonwealth of Australia, do hereby declare that I have this day assented, in Her Majesty's name, to the Bills passed by the Parliament of the said State, the titles whereof are hereunder set forth, together with the short titles, that is to say:

No. 9429. "An Act to amend Section 5 of the *Cattle Compensation Act 1967*." (*Cattle Compensation (Amendment) Act 1980*.)

No. 9430. "An Act to supplement *The Bank of Adelaide (Merger) Act 1980* of the State of South Australia which provides for the transfer to Australia and New Zealand Banking Group Limited of the undertaking of The Bank of Adelaide and for the transfer to Australia and New Zealand Savings Bank Limited of the undertaking of The Bank of Adelaide Savings Bank Limited and for other purposes." (*The Bank of Adelaide (Merger) Act 1980*.)

Given under my Hand and the Seal of the State of Victoria aforesaid, at Melbourne, this thirtieth day of September, in the year of our Lord One thousand nine hundred and eighty and in the twenty-ninth year of the reign of Her Majesty Queen Elizabeth II.

(L.S.) HENRY WINNEKE

By His Excellency's Command

R. J. HAMER  
Premier

GOD SAVE THE QUEEN!

No. 9429 shall come into operation on the day on which it receives the Royal Assent.

No. 9430 shall be deemed to have come into operation on 1 October 1980.

#### Land Act 1958

### UNALIENATED CROWN LANDS MADE AVAILABLE FOR SETTLEMENT UNDER IMPROVEMENT PURCHASE LEASES

#### PROCLAMATION

By His Excellency the Governor of the State of Victoria and its Dependencies in the Commonwealth of Australia, &c., &c., &c.

I, the Governor of the State of Victoria, in the Commonwealth of Australia, by and with the advice of the Executive Council of the said State, pursuant to the pro-

visions of section 153 of the *Land Act 1958*, do hereby proclaim the Crown lands hereinafter described to be made available for settlement under improvement purchase leases at the purchase prices respectively mentioned, viz.:

Allotment No.	Parish	Area	Purchase Price	
			ha	\$
51A	Bitchigal	17.8	700.00	(L5-2147)
12B	Korrak Korrak	61	3000.00	(L5-2189)
22A	Llaniduck	85	2400.00	(L5-2149)
51, 52, 53	Faignie	1417	5300.00	(L5-2051)
25	Piangil West	316.6	5040.00	(L5-2055)
47	Piangil West	248	4650.00	(L5-2155)

Given under my Hand and the Seal of the State of Victoria aforesaid, at Melbourne, this twenty-third day of September, in the year of our Lord One thousand nine hundred and eighty, and in the twenty-ninth year of the reign of Her Majesty Elizabeth the Second, Queen of Australia.

(L.S.) HENRY WINNEKE

By His Excellency's Command

W. V. HOUGHTON  
Minister of Lands

GOD SAVE THE QUEEN!

#### Land Act 1958

### UNALIENATED CROWN LANDS MADE AVAILABLE FOR SETTLEMENT UNDER IMPROVEMENT PURCHASE LEASES

#### PROCLAMATION

By His Excellency the Governor of the State of Victoria and its Dependencies in the Commonwealth of Australia, &c., &c., &c.

I, the Governor of the State of Victoria, in the Commonwealth of Australia, by and with the advice of the Executive Council of the said State, pursuant to the provisions of section 153 of the *Land Act 1958*, do hereby proclaim the Crown lands hereinafter described to be available for settlement under improvement purchase leases at the purchase prices respectively mentioned, viz.:

Allotment No.	Parish	Area	Purchase Price	
			ha	\$
22	Boga	106	5200.00	(L5-2165)
16A	Kalpiening	25.74	650.00	(L5-2182)
12	Tittybong	16.08	1000.00	(L5-2183)

Given under my Hand and the Seal of the State of Victoria aforesaid, at Melbourne, this twenty-third day of September, in the year of our Lord One thousand nine hundred and eighty, and in the twenty-ninth year of the reign of Her Majesty Elizabeth the Second, Queen of Australia.

(L.S.) HENRY WINNEKE

By His Excellency's Command

W. V. HOUGHTON  
Minister of Lands

GOD SAVE THE QUEEN!

Land Act 1958  
ROAD PROCLAIMED

PROCLAMATION

By His Excellency the Governor of the State of Victoria and its Dependencies in the Commonwealth of Australia, &c., &c., &c.

I, the Governor of the State of Victoria, in the Commonwealth of Australia, by and with the advice of the Executive Council of the said State, pursuant to the provisions of section 25 (3) (c) of the Land Act 1958, do hereby proclaim as road the Crown land hereinafter described, viz.:

Parish of Kevington, being the land indicated by hatching on plan hereunder—(K.116(2)) (L.7-312).

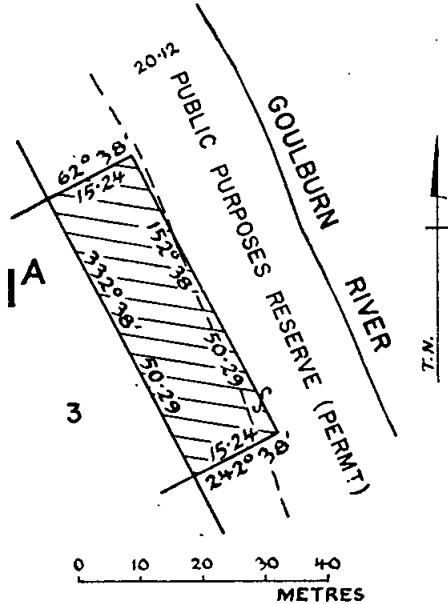

Given under my Hand and the Seal of the State of Victoria aforesaid, at Melbourne this twenty-third day of September, in the year of our Lord One thousand nine hundred and eighty, and in the twenty-ninth year of the reign of Her Majesty Elizabeth the Second, Queen of Australia.

(L.S.) HENRY WINNEKE

By His Excellency's Command

W. V. HOUGHTON  
Minister of Lands

GOD SAVE THE QUEEN!

Land Act 1958  
ROAD PROCLAIMED

PROCLAMATION

By His Excellency the Governor of the State of Victoria and its Dependencies in the Commonwealth of Australia, &c., &c., &c.

I, the Governor of the State of Victoria, in the Commonwealth of Australia, by and with the advice of the Executive Council of the said State, pursuant to the provisions of section 25 (3) (c) of the Land Act 1958, do hereby proclaim as road the Crown land hereinafter described, viz.:

Parish of Ballarat, being the land indicated by hatching on plan hereunder—(B.126(15)) (L.3-1004).

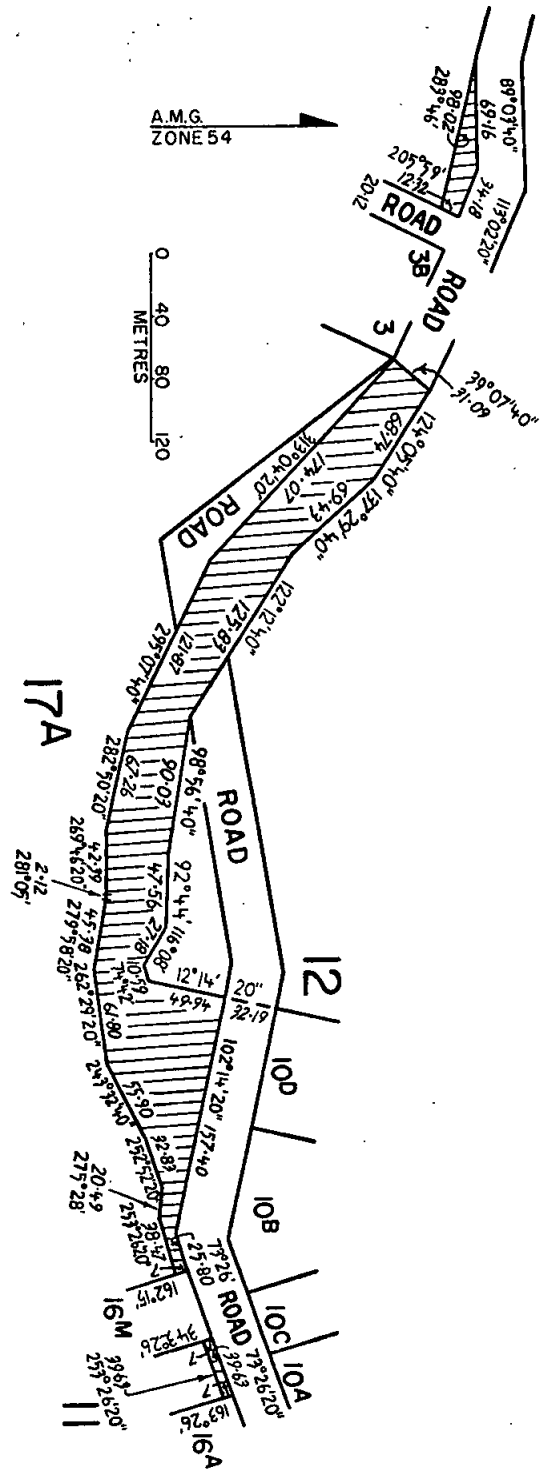

Given under my Hand and the Seal of the State of Victoria aforesaid, at Melbourne, this twenty-third day of September, in the year of our Lord One thousand nine hundred and eighty, and in the twenty-ninth year of the reign of Her Majesty Elizabeth the Second, Queen of Australia.

(L.S.) HENRY WINNEKE

By His Excellency's Command

W. V. HOUGHTON  
Minister of Lands

GOD SAVE THE QUEEN !

Land Act 1958

LAND DECLARED UNDER SECTION 22c OF THE  
LAND ACT 1958

PROCLAMATION

By His Excellency the Governor of the State of Victoria and its Dependencies in the Commonwealth of Australia, &c., &c., &c.

I, the Governor of the State of Victoria, in the Commonwealth of Australia, by and with the advice of the Executive Council of the said State, pursuant to the provisions of section 22c (2) of the *Land Act 1958*, and upon receipt of certification by the clerk of the municipality concerned (Shire of Heytesbury) that the subject land constitutes land which is or has been used for recreational purposes being a site for a hall used by the public, do by this Proclamation declare all that piece of land being part of Crown allotment 40A, Parish of Pomboineit, and being the whole of the land described in Certificate of Title Volume 5138 Folio 551—(C.101691).

Given under my Hand and the Seal of the State of Victoria aforesaid, at Melbourne, this twenty-third day of September, in the year of our Lord One thousand nine hundred and eighty, and in the twenty-ninth year of the reign of Her Majesty Elizabeth the Second, Queen of Australia.

(L.S.) HENRY WINNEKE

By His Excellency's Command

W. V. HOUGHTON  
Minister of Lands

GOD SAVE THE QUEEN !

PUBLIC HIGHWAY—CITY OF BROADMEADOWS

PROCLAMATION

By His Excellency the Governor of the State of Victoria and its Dependencies in the Commonwealth of Australia, &c., &c., &c.

Whereas by the *Local Government Act 1958*, section 519 it is amongst other things enacted that it shall be lawful for the Governor in Council at any time and from time to time upon the request of the council of any municipality by notice in the *Government Gazette* to proclaim any land reserved used or by purchase or exchange acquired for a street, road, highway, thoroughfare, bridge, square, court, alley, or right-of-way or any street, road, lane or passage made or laid out or proposed to be made or laid out on any land of which a plan of subdivision delineating that street, road, lane or passage has been sealed with the seal of the municipality under subdivision (3) of Division 9 of Part XIX. of the *Local Government Act 1958* or a corresponding previous enactment to be a public highway and that land shall thereupon and thenceforth from the date of such Proclamation become and be absolutely dedicated to the public as a public highway within the meaning of the law then or thereafter in force.

And whereas the Council of the City of Broadmeadows has requested that the land hereinafter mentioned, used for a street to be so declared to be a public highway.

Now therefore, I, the Governor of the State of Victoria, in the Commonwealth of Australia by and with the advice of the Executive Council of the said State, do by this Proclamation declare that the Riggall Street Overpass

Bridge Deck as shown by hatching on the plan hereunder shall be a public highway within the meaning of the said Act.

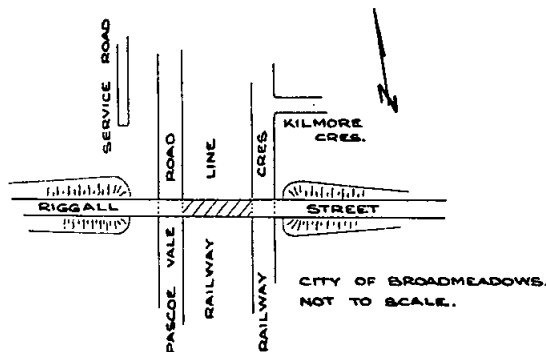

Given under my Hand and the Seal of the State of Victoria aforesaid at Melbourne this twenty-third day of September in the year of our Lord One thousand nine hundred and eighty and in the twenty-ninth year of the reign of Her Majesty Queen Elizabeth II.

(L.S.) HENRY WINNEKE

By His Excellency's Command

D. G. CROZIER  
Minister for Local Government

GOD SAVE THE QUEEN !

Weights and Measures Act 1958

ALTERATION OF CONSTITUTION OF THE BARWON  
WEIGHTS AND MEASURES UNION

PROCLAMATION

By His Excellency the Governor of the State of Victoria and its Dependencies in the Commonwealth of Australia, &c., &c., &c.

Whereas by the *Weights and Measures Act 1958*, section 44, it is amongst other things enacted that the Governor in Council may at the request of municipalities constituting a Union by Proclamation alter or revoke any Proclamation declaring such municipalities to be a Union for the purposes of the aforesaid Act:

And whereas the City of South Barwon, the Borough of Queenscliffe and the Shires of Bannockburn, Barrabool and Winchelsea do constitute a Union for the purposes of the *Weights and Measures Act 1958*, under the name of "Barwon Weights and Measures Union".

And whereas the Councils of each of the said municipalities have requested that the Borough of Queenscliffe shall cease to be included in the said Union:

Now therefore I, the Governor of the State of Victoria by and with the advice of the Executive Council of the said State and in pursuance of the powers conferred by the *Weights and Measures Act 1958*, do by this Proclamation alter the Proclamation under which the Barwon Weights and Measures Union is constituted on and from 1 October 1980, and declare that on and from such date—

- the City of South Barwon and the Shires of Bannockburn, Barrabool and Winchelsea shall constitute a Union under the name "Barwon Weights and Measures Union"; and
- the apportionment of the expenses devolving on the said Union under the *Weights and Measures Act* shall be fixed as follows:

City of South Barwon	65.72 per centum
Shire of Bannockburn	7.51 per centum
Shire of Barrabool	9.86 per centum
Shire of Winchelsea	16.91 per centum

Given under my Hand and the Seal of the State of Victoria aforesaid, at Melbourne this twenty-third day of September in the year of our Lord One thousand nine hundred and eighty, and in the twenty-ninth year of the reign of Her Majesty Queen Elizabeth II.

(L.S.) HENRY WINNEKE

By His Excellency's Command  
D. G. CROZIER  
Minister for Local Government  
GOD SAVE THE QUEEN!

VERMIN AND NOXIOUS WEEDS ACT 1958

PROCLAMATION

By His Excellency the Governor of the State of Victoria and its Dependencies in the Commonwealth of Australia, &c., &c., &c.

I, the Governor of the State of Victoria, in the Commonwealth of Australia, by and with the advice of the Executive Council of the said State, pursuant to the provisions of section 6 (4) (a) of the *Vermin and Noxious Weeds Act 1958*, do by this Proclamation declare that it shall be the duty of the Minister of Lands to take reasonable action to destroy and suppress such noxious weeds as are specified in the First Schedule hereof on all roads (other than private roads and roads held or occupied under lease or licence granted by the Crown or by any municipality), and to keep clear and free of such noxious weeds as are specified in the First Schedule hereof all roads (other than private roads and roads held or occupied under lease or licence granted by the Crown or by any municipality) in the whole of the State of Victoria, except those parts set out in the Second Schedule hereof.

FIRST SCHEDULE  
NOXIOUS WEEDS

Common Name	Botanical or Scientific Name
African feather grass	<i>Pennisetum macrourum</i> Trin.
Californian burr	<i>Xanthium orientale</i> L.
Camel thorn	<i>Athagi pseudalhagi</i> (Bieb.) (Desv.)
Cape tulip	<i>Homeria breyniana</i> (L.) G. J. Lewis and H. Miniata (Andr.) (Sweet)
Chilean cestrum	<i>Cestrum parqui</i> L' Hérit.
Devil's claw	<i>Proboscidea louisianica</i> (Mill.) Thell. and <i>Ibicella lutea</i> (Lindl.) v. Esetline
Erect prickly pear	<i>Opuntia stricta</i> (Haw.) Haw.
Golden thistle	<i>Scolymus hispanicus</i> L.
Hardheads	<i>Centaurea repens</i> L.
Illyrian thistle	<i>Onopordum illyricum</i> L.
Ivy-leaf sida	<i>Sida leprosa</i> (Ortega) K. Schumann
Noogoora burr	<i>Xanthium pungens</i> Wallr.
Nodding thistle	<i>Carduus nutans</i> L.
Perennial ragweed	<i>Ambrosia psilostachya</i> DC.
Perennial thistle	<i>Cirsium arvense</i> (L.) Scop.
Poverty weed	<i>Iva axillaris</i> Pursh.
Prairie ground cherry	<i>Physalis viscosa</i> L.
St. Peter's wort	<i>Hypericum tetrapterum</i> Fries.
Scotch thistle	<i>Onopordum acanthium</i> L.
Serrated tussock	<i>Nassella trichotoma</i> (Nees.) Hack. ex Arech.
Silver-leaf nightshade	<i>Solanum elaeagnifolium</i> Cav.
Spiny burr grass	<i>Cenchrus longispinus</i> (Hack.) Fern
Spiny emex	<i>Emex australis</i> Steinh.
Tangled hypericum	<i>Hypericum triquetrifolium</i> Turra
Wild garlic	<i>Allium vineale</i> L.

SECOND SCHEDULE

The Parishes of Boroondara, Bulleen, Cut-paw-paw, Dandenong, Jika Jika, Melbourne North, Melbourne South, Moorabbin, Mordialloc, Mulgrave, Nunawading, Prahran, that part of the Parish of Doutta Galla within the municipal boundaries of the City of Essendon, that part of the Parish of Doutta Galla within the municipal boundaries of the City of Melbourne, that part of the Parish of Lyndhurst within the municipal boundaries of the City of Chelsea, and that part of the Parish of Keelbundora situated south of Crown allotments 8, 9, 10, 11, 12 and Mont Park Mental Hospital Reserve.

Given under my Hand and the Seal of the State of Victoria aforesaid, at Melbourne, this twenty-third day of September, in the year of our Lord One thousand nine hundred and eighty, and in the twenty-ninth year of the reign of Her Majesty Elizabeth the Second, Queen of Australia.

(L.S.) HENRY WINNEKE

By His Excellency's Command  
W. V. HOUGHTON  
Minister of Lands  
GOD SAVE THE QUEEN!

GOVERNMENT NOTICES

*Pounds Act 1958*  
CITY OF HAMILTON

Table of Rates to be charged for the trespass of cattle, and their sustenance while impounded fixed by the Council of the City of Hamilton.

A. For Trespass

Description of Cattle Trespassing	Upon tillage land enclosed by a substantial fence	Upon land other than tillage land enclosed by a substantial fence
	\$	\$
For every sheep	0.60	0.10
For every goat	6.00	3.00
For every pig	6.00	3.00
For every head of other cattle	6.00	3.00

	\$
In addition for the trespass of any entire horse	20.00
In addition for the trespass of any bull	20.00
In addition for the trespass of any ram	20.00

B. For Sustenance

Description of Cattle	Amounts to be charged daily for sustenance while impounded
	\$
For every sheep	0.20
For every goat	2.00
For every pig	2.00
For every head of other cattle	2.00

NOTE—Section 10A of the *Pounds Act 1958* provides that where a person intending to impound cattle conveys them to the pound or makes arrangements for their conveyance to the pound there shall be payable as a transport rate the expenses reasonably incurred by him in so conveying them to the pound or making arrangements for their conveyance to the pound.

By Order of the Council  
R. J. WORLAND, Town Clerk

Approved by the Governor in Council, 23 September 1980  
—TOM FORRISTAL, Clerk of the Executive Council.

*Pounds Act 1958*  
SHIRE OF COHUNA

Table of Rates to be charged for the Trespass of Cattle, and their sustenance while impounded fixed by the Council of the Shire of Cohuna.

A. For Trespass

Description of Cattle Trespassing	Upon	Upon land
	tillage land enclosed by a substantial fence	other than tillage land enclosed by a substantial fence
	\$	\$
For every sheep	0.10	0.10
For every goat	3.00	3.00
For every pig	3.00	3.00
For every head of other cattle	3.00	3.00
	\$	
In addition for the trespass of any entire horse		20.00
In addition for the trespass of any bull		20.00
In addition for the trespass of any ram		20.00

B. For Sustenance

Description of Cattle	Amounts to be charged daily for sustenance while impounded
	\$
For every sheep	0.50
For every goat	2.00
For every pig	2.00
For every head of other cattle	2.00

NOTE—Section 10A of the *Pounds Act 1958* provides where a person intending to impound cattle conveys them to the pound or makes arrangements for their conveyance to the pound there shall be payable as a transport rate the expenses reasonably incurred by him in so conveying them to the pound or making arrangements for their conveyance to the pound.

By Order of the Council

G. B. KOHLMAN, Shire Secretary

Approved by the Governor in Council, 23 September 1980  
—TOM FORRISTAL, Clerk of the Executive Council.

The common seal of the President, Councillors and Ratepayers of the Shire of Ararat was hereunto affixed, 19 August 1980, in the presence of—

(SEAL) K. M. COAD, President  
W. A. NICHOLSON, Councillor  
L. M. CONSTABLE, Secretary

Confirmed by the Governor in Council, 23 September 1980—TOM FORRISTAL, Clerk of the Executive Council

SHIRE OF BULN BULN  
ROAD DEVIATION ORDER

In pursuance of the powers conferred by sections 522 and 526 of the *Local Government Act 1958*, the Council of the Shire of Buln Buln doth hereby direct that the land in the Township of Longwarry, Parish of Drouin West, shown hatched on the plan hereunder, which has been taken, purchased or acquired by it, shall be a public highway from and after the date of publication of this Order in the *Government Gazette*, and doth declare that such land shall be a public highway in lieu of the land in the said Parish shown cross-hatched on the said plan.

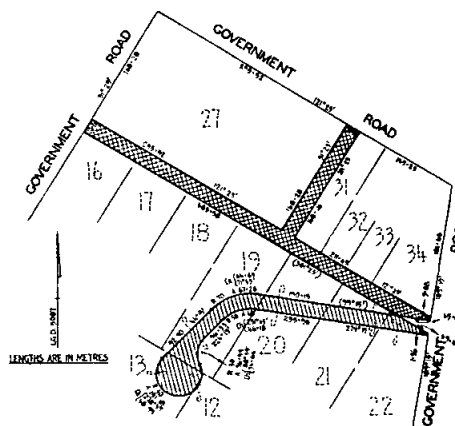

The common seal of the President, Councillors and Ratepayers of the Shire of Buln Buln was hereunto affixed, 25 October 1979, in the presence of—

(SEAL) I. M. STOLL, President  
J. DELZOPPO, Councillor  
K. PRETTY, Secretary

Confirmed by the Governor in Council, 23 September 1980—TOM FORRISTAL, Clerk of the Executive Council

SHIRE OF ARARAT  
ROAD DEVIATION ORDER

Pursuant to the provisions of sections 522 and 526 of the *Local Government Act 1958* the Council of the Shire of Ararat hereby directs that the land in the Parish of Walla Walla indicated by hatching on the diagram hereunder which has been purchased taken or acquired by it shall be a public highway on and from the date of publication of this Order in the *Government Gazette* and declares that such land shall be a public highway in lieu of the land indicated by cross hatching on the said diagram.

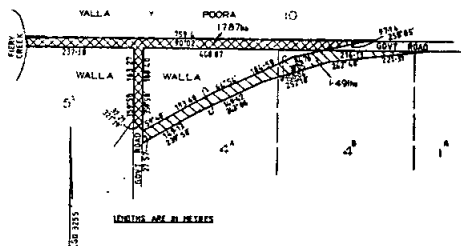

SHIRE OF KERANG  
ROAD DEVIATION ORDER

Pursuant to the provisions of sections 522 and 526 of the *Local Government Act 1958* the Council of the Shire of Kerang hereby directs that the land in the Parish of Benjeroop indicated by hatching on the diagram hereunder which has been purchased or acquired by it shall be a public highway on and from the date of publication of

this Order in the *Government Gazette* and declares that such land shall be a public highway in lieu of the land indicated by cross hatching on the said diagram.

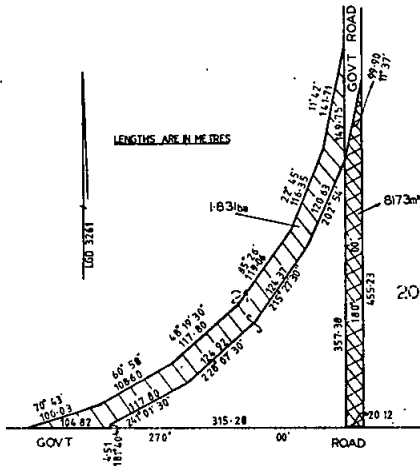

The common seal of the President, Councillors and Ratepayers of the Shire of Kerang was hereunto affixed, 12 August 1980—

(SEAL) D. W. FENTON, President  
J. M. PARKER, Councillor  
P. L. WIGNALL, Secretary

Confirmed by the Governor in Council, 23 September 1980—TOM FORRISTAL, Clerk of the Executive Council

SHIRE OF KERANG  
ROAD DEVIATION ORDER

Pursuant to the provisions of sections 522 and 526 of the *Local Government Act 1958* the Council of the Shire of Kerang hereby directs that the land in the Parish of Meran indicated by hatching on the diagram hereunder which has been purchased or acquired by it shall be a public highway on and from the date of publication of this Order in the *Government Gazette* and declares that such land shall be a public highway in lieu of the land indicated by cross hatching on the said diagram.

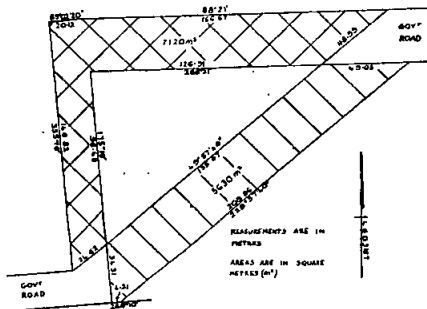

The common seal of the President, Councillors and Ratepayers of the Shire of Kerang was hereunto affixed, 9 April 1980—

(SEAL) D. W. FENTON, President  
A. ALEXANDER, Councillor  
P. L. WIGNALL, Secretary

Confirmed by the Governor in Council, 23 September 1980—TOM FORRISTAL, Clerk of the Executive Council

SHIRE OF MANSFIELD  
ROAD DEVIATION ORDER

Pursuant to the provisions of sections 522 and 526 of the *Local Government Act 1958* the Council of the Shire of Mansfield hereby directs that the land in the Parish of Loyola indicated by hatching on the diagram hereunder which has been purchased taken or acquired by it shall be a public highway on and from the date of publication of this Order in the *Government Gazette* and declares that such land shall be a public highway in lieu of the land indicated by cross hatching on the said diagram.

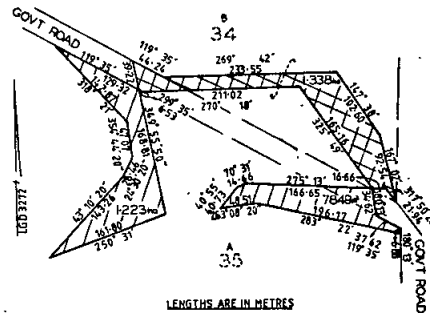

Dated 12 September 1980

The common seal of the President, Councillors and Ratepayers of the Shire of Mansfield was hereto affixed, in the presence of—

(SEAL) JAMES M. CUMMINS, Councillor  
ROBERT RITCHIE, Councillor  
F. WALSHE, Secretary

Confirmed by the Governor in Council, 23 September 1980—TOM FORRISTAL, Clerk of the Executive Council

Local Government Act 1958

NOTICE OF CONFIRMATION OF AN ORDER OF THE COUNCIL OF THE SHIRE OF SHERBROOKE ADOPTING A PROPOSAL FOR THE CLOSURE OF MOUNT VIEW ROAD, UPPER FERNTREE GULLY TO THROUGH TRAFFIC

Pursuant to the provisions of section 539c of the *Local Government Act 1958* the Governor in Council, on 23 September 1980 confirmed an Order of the Council of the Shire of Sherbrooke made on 17 March 1980 adopting a proposal for the closure of Mount View Road, Upper Ferntree Gully to through traffic by the erection of barriers at the location shown on the plan hereunder.

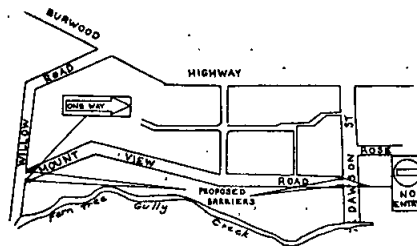

TOM FORRISTAL  
Clerk of the Executive Council

At the Executive Council Chamber  
Melbourne, 23 September 1980

SHIRE OF YEA  
ROAD DEVIATION ORDER

In pursuance of the powers conferred by sections 522 and 526 of the Local Government Act 1958, the Council of the Shire of Yea doth hereby direct that the land in the Parish of Dropmore shown hatched on the plan hereunder, which has been taken purchased or acquired by it, shall be a public highway from and after the date of publication of this Order in the Government Gazette, and doth declare that such land shall be a public highway in lieu of the land in the Parish shown cross-hatched on the said plan.

tion of this Order in the Government Gazette, and doth declare that such land shall be a public highway in lieu of the land in the said Parish shown cross-hatched on the said plan.

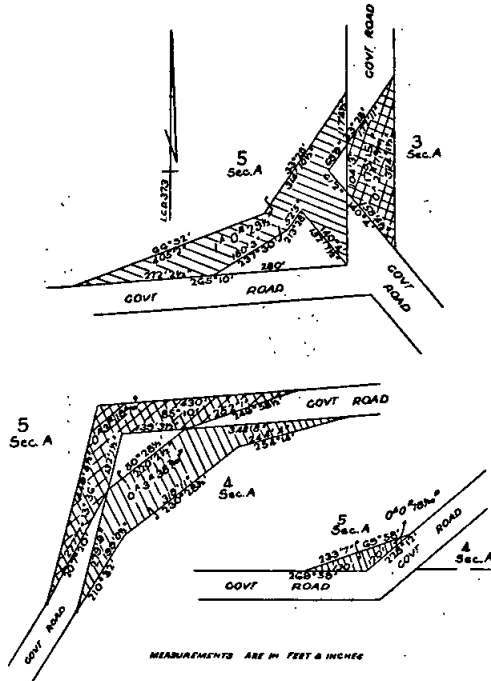
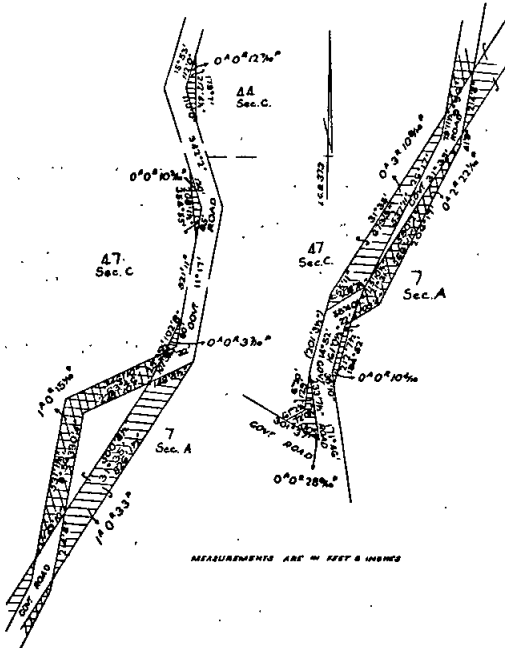

The common seal of the President, Councillors and Ratepayers of the Shire of Yea was hereunto affixed, 6 December 1974, in the presence of—

(SEAL) GORDON A. BETT, President  
DON McLEISH, Councillor  
F. F. BERKERY, Secretary

The common seal of the President, Councillors and Ratepayers of the Shire of Yea was hereunto affixed, 6 December 1974, in the presence of—

(SEAL) GORDON A. BETT, President  
DON McLEISH, Councillor  
F. F. BERKERY, Secretary

Confirmed by the Governor in Council, 23 September 1980—TOM FORRISTAL, Clerk of the Executive Council.

Confirmed by the Governor in Council, 23 September 1980—TOM FORRISTAL, Clerk of the Executive Council

SHIRE OF YEA  
ROAD DEVIATION ORDER

In pursuance of the powers conferred by sections 522 and 526 of the Local Government Act 1958, the Council of the Shire of Yea doth hereby direct that the land in the Parish of Dropmore shown hatched on the plan hereunder, which has been taken purchased or acquired by it, shall be a public highway from and after the date of publica-

SHIRE OF YEA  
ROAD DEVIATION ORDER

In pursuance of the powers conferred by sections 522 and 526 of the Local Government Act 1958, the Council of the Shire of Yea doth hereby direct that the land in the Parish of Dropmore shown hatched on the plan hereunder, which has been taken purchased or acquired by it, shall be a public highway from and after the date of publication of this Order in the Government Gazette, and

doth declare that such land shall be a public highway in lieu of the land in the said Parish shown cross-hatched on the said plan.

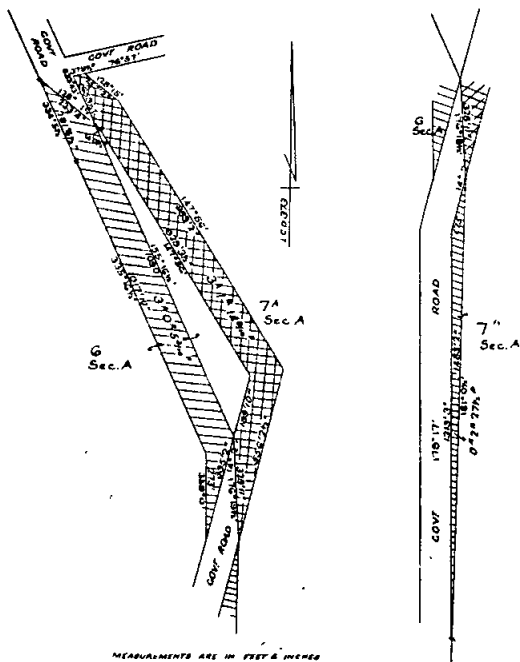

The common seal of the President, Councillors and Ratepayers of the Shire of Yea was hereunto affixed, 6 December 1974, in the presence of—

(SEAL) GORDON A. BETT, President  
DON McLEISH, Councillor  
F. F. BERKERY, Secretary

Confirmed by the Governor in Council, 23 September 1980—TOM FORRISTAL, Clerk of the Executive Council

Forests Act 1958, No. 6254  
DECLARATION OF PROHIBITED PERIOD

In pursuance of the powers conferred by section 3 of the Forests Act 1958, I, Frederick James Granter, Her Majesty's Minister of Forests in the State of Victoria, hereby declare a Prohibited Period in respect of any fire protected area (other than State Forest, National Park or Protected Public Land) at the times, dates, and in the municipalities specified in the Schedule hereunder.

SCHEDULE 1

The Prohibited Period shall commence at midnight between 1 October and 2 October 1980, and end between the 30 April and 1 May 1981, in the municipalities shown hereunder:

- The Shires of—
- Avon
- Bairnsdale
- Maffra
- Omeo
- Orbost
- Tambo

29 September 1980

F. J. GRANTER  
Minister of Forests

COUNTRY FIRE AUTHORITY

PERMISSION TO HOLD FIRE BRIGADE DEMONSTRATIONS

In pursuance of the provisions of section 103 of the Country Fire Authority Act 1958, the Country Fire Authority has granted permission for the holding of fire brigade demonstrations as under:—

Urban Fire Brigades

- At Fairfield on Saturday, 1 November 1980.
- At Woodend on Sunday, 23 November 1980.
- At St. Arnaud on Sunday, 30 November 1980 in lieu of at Dunolly on Sunday, 30 November 1980.
- At Kyneton on Sunday, 7 December 1980.
- At St. Arnaud on Saturday, 31 January 1981.
- At Bendigo on Saturday and Sunday, 21 and 22 February 1981.
- At Koroit on Saturday, 28 February 1981.
- At Swan Hill on Saturday, Sunday and Monday, 7, 8 and 9 March 1981.

Rural Fire Brigades

- At Clyde on Sunday, 30 November 1980.
- At Whittlesea on Saturday and Sunday, 4 and 5 April 1981.

L. T. D'ARCY, Secretary

DEPARTMENT OF THE PREMIER  
CONSULAR CORPS

His Excellency the Governor of Victoria has advised that the following amendments have been made to the list of Consular Corps resident in Melbourne:

LEBANON

Consul of Lebanon—Mr. H. Dimachkieh (with effect from 25 July 1980).

URUGUAY

Honorary Consul for Uruguay—Incumbent Honorary Consul Mr I. Rice has resigned his appointment with effect from 1 April 1980.

The Office is now vacant.  
24 September 1980

R. J. HAMER  
Premier

CHILDREN'S COURT ACT  
DAYS AND HOURS APPOINTED

His Excellency the Governor of the State of Victoria, by and with the advice of the Executive Council thereof, has by Order made on 23 September 1980, and pursuant to the provisions of section 4 (3) of the Children's Court Act 1973, appointed the days and hours contained in the Schedule below, public holidays excepted, for the holding of Children's Courts at the places named in such Schedule in lieu of the days and hours heretofore appointed—to take effect, as from and inclusive, on the dates shown in the Schedule below.

SCHEDULE	
Place	Day and Hour
DAYLESFORD	Alternate Fridays at 9.30 a.m. on and from 10 October 1980.
CLUNES	Every eighth Friday at 9.30 a.m. on and from 17 October 1980.
LANCEFIELD	Every eighth Friday at 9.30 a.m. on and from 14 November 1980.
BEAUFORT	Every fourth Friday at 9.30 a.m. on and from 17 October 1980
DUNOLLY	Every fourth Friday at 9.30 a.m. on and from 3 October 1980
MARYBOROUGH	Every alternate Thursday at 9.30 a.m. on and from 16 October 1980.

TOM FORRISTAL  
Clerk of the Executive Council  
At the Executive Council Chamber  
Melbourne, 23 September 1980



Police Offences Act 1958, No. 6337

DIVISION 1A—STATE CLASSIFICATION OF  
PUBLICATIONS BOARD

Take note that the State Classification of Publications Board has classified the following publications in accordance with the provisions of section 180H (1) of the Police Offences Act 1958.

Each publication shall be subject to the following restrictions:

- (a) it shall not be offered for sale, sold, delivered, exhibited or displayed to any person under the age of 18 years;
- (b) it shall not be made available for inspection or perusal to any person under the age of 18 years;
- (c) it shall not be exhibited or displayed in any place to which persons under the age of 18 years have access or so that it is visible from any such place;
- (d) it shall not be advertised in any manner whatsoever.

SCHEDULE OF PUBLICATIONS

Title	Distributor
Arrogant Amazon Vs Bondage Burglar	Lovecraft Shop
Best Of Bondage Vol. 3 No. 1	Venus Enterprises Pty. Ltd.
Bondage Slaves Of The Bridewell	Lovecraft Shop
Cavalier Yearbook—1981 Edition	Gordon & Gotch (A'sia) Ltd.
Club International Vol. 9 No. 11	Gordon & Gotch (A'sia) Ltd.
Genesis—November, 1980	Gordon & Gotch (A'sia) Ltd.
Guise—Premier Issue	Lovecraft Shop
Guise—No. 2	Lovecraft Shop
High Priestess Of Sex	Melbourne Wholesale Newsagency Pty. Ltd.
Irving Klaw Years, the 1948-1963 Vol. 1	Venus Enterprises Pty. Ltd.

Title	Distributor
Lee Carvel's Heavy Leather—Issue No. 1	Venus Enterprises Pty. Ltd.
Libertine, the—Issue No. 8	Gordon & Gotch (A'sia) Ltd.
Lotus Blossom Vol. 1 No. 1	Venus Enterprises Pty. Ltd.
Massage Parlor Stud	Melbourne Wholesale Newsagency Pty. Ltd.
Mayfair Vol. 15 No. 10	Gordon & Gotch (A'sia) Ltd.
Men Only Vol. 45 No. 10	Gordon & Gotch (A'sia) Ltd.
Popular Jokes—November, 1980	Gordon & Gotch (A'sia) Ltd.
Pub—November, 1980	Gordon & Gotch (A'sia) Ltd.
Sex Slave Manor	Melbourne Wholesale Newsagency Pty. Ltd.
Swank—November, 1980	Gordon & Gotch (A'sia) Ltd.
Taskmaster Vol. 2 No. 1	Venus Enterprises Pty. Ltd.
Velvet Kiss, the	Melbourne Wholesale Newsagency Pty. Ltd.
Women's Lib Bondage Duel	Lovecraft Shop

J. SMITH, Secretary  
State Classification of Publications Board

NOTICE TO MARINERS  
[No. 42 (T) OF 1980]

AUSTRALIA—VICTORIA  
PORT PHILLIP

*Coles Channel—Pile Missing*

Coles Channel No. 3 Pile (Lat. 38 deg. 12.9 min. S., Long. 144 deg. 42.8 min. E. approximately) is missing. Further notice will issue when the pile has been replaced.

*Chart Temporarily Affected—AUS. 158.*

A. J. WAGGLEN  
Port Officer

Public Works Department  
Ports and Harbors Division  
168 Exhibition Street  
Melbourne, 3000, 24 September 1980

NOTICE TO MARINERS  
[No. 41 (T) OF 1980]

AUSTRALIA—VICTORIA

The following information which has been received from the Harbor Master, Geelong, is published for general information.

A. J. WAGGLEN  
Port Officer

Public Works Department  
Ports and Harbors Division  
168 Exhibition Street  
Melbourne, 3000, 24 September 1980

THE GEELONG HARBOR TRUST COMMISSIONERS  
PORT OF GEELONG

*Dredging Operations in Progress*

*Date*—On or about 1 October 1980.

*Location*—Bulk Wheat Pier F. R. Light (38 deg. 06.9 min. S., 144 deg. 21.8 min. E. approximately).

*Details*—Dredging operations will commence in this vicinity in preparation for the construction of new berths northward of the Bulk Wheat Pier. Dredge spoil will be dumped close to the shoreline between the dredging area and Corio Quay South.

*Cut Line*—Commencing at a point 317 deg. 150 min. from the above light (i.e., at the northern most point of the Pier), a line 047 deg. 178 min. thence 128 deg. 244 min. thence 013 deg. 244 min. thence 061 deg. to the western edge of the Corio Channel.

*Depths*—To the southward of this line depths will be increased to 11 metres.

To the northward of the line depths will be less than charted.

*Signals*—The work will be undertaken by a stationary cutter suction dredge which will pump spoil through an articulated pipeline. Regulation signals will be exhibited.

*Charts Temporarily Affected*—AUS. 143 AUS. 157.

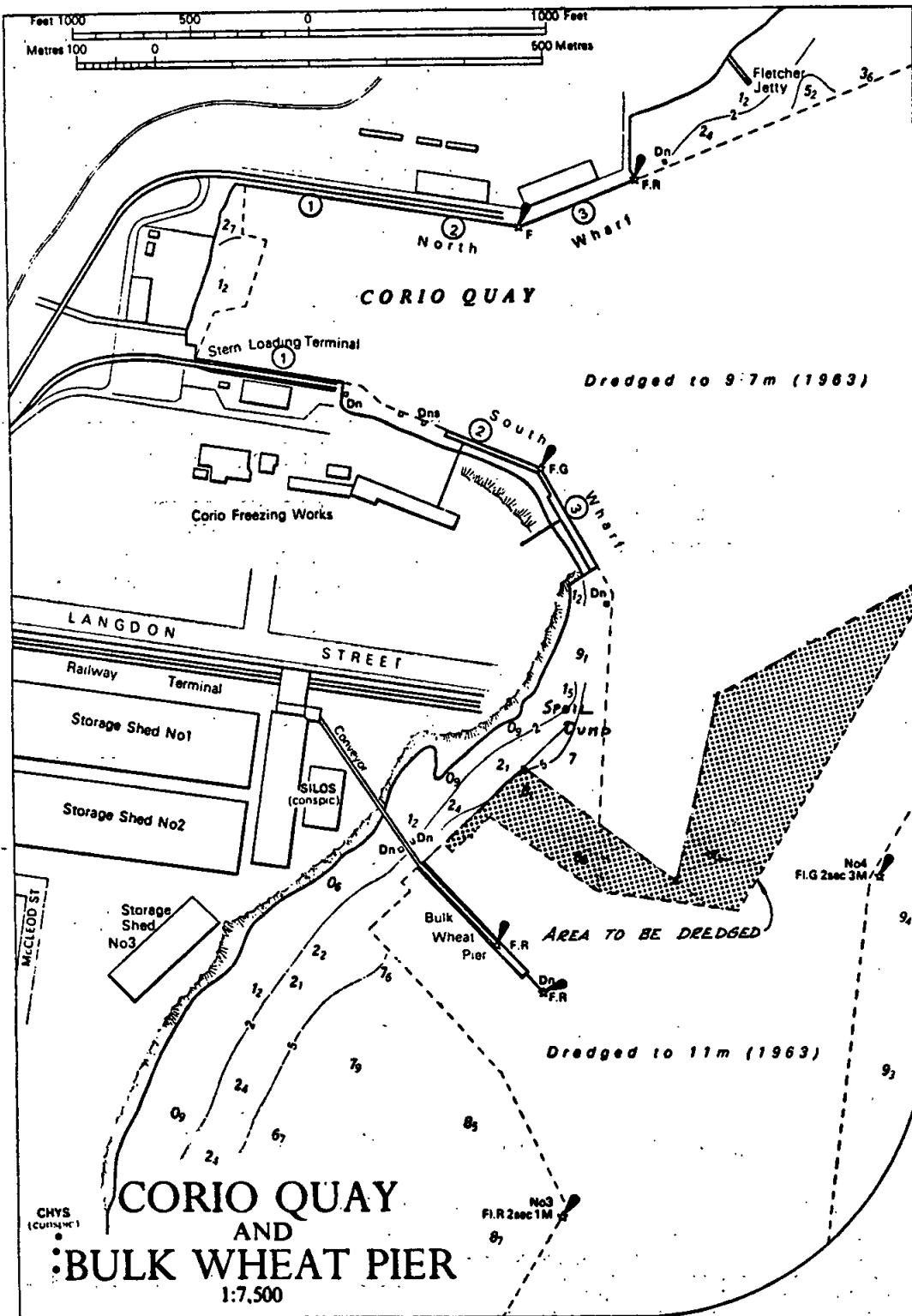

DEPTHS IN METRES

Transport Regulation Act  
**TRANSPORT REGULATION BOARD**  
 HEARING OF APPLICATIONS

Notice is hereby given that the following applications will be considered by the Transport Regulation Board on 21 October 1980.

WHISTON, E. V., Estate of the Late, North Fitzroy. Application for two special purpose vehicle licences in respect of a 1926 Rolls Royce sedan and a 1928 Ford Touring sedan to operate from 269 St. Georges Road, North Fitzroy for the carriage of passengers for wedding parties and promotional work involving the use of vintage cars.

Applications by the persons listed hereunder for one Metropolitan Taxi licence to be issued subject to the cancellation of each Suburban Taxi licence shown.

GRAMBAS, V., Newport; S.T.5252.

JEFFS, D. J., Rowville; S.T.6314.

ROBERTS, B. J., Brunswick; S.T.6429.

Application for renewal of licences as shown by the persons listed hereunder to operate under the same terms and conditions.

CARTER, P. R., Mildura; T.S.898.

DAVIES, L. W., Lindenow South; T.S.1488.

GRUNBERG, R., Caulfield; M.T.1803 and M.T.4578.

HARRINGTON, V. C., Bendigo; U.T.368.

HUGHES HIRE CARS PTY. LTD., South Melbourne; M.H.2470, M.H.2471, M.H.2472, M.H.2473, M.H.2474, M.H.2477, M.H.2478, M.H.2479, M.H.2481, M.H.2483, M.H.2485 and M.H.2486.

MCMAHON, M. F., Stratford; T.S.1471.

O'DONOGHUE, A. W. & W. A., Ocean Grove; C.T.139.

THURGOOD, E. I., South Yarra; M.T.1464T.

WHITEHORSE BUS SERVICE PTY. LTD., Box Hill North; M.O.169, M.O.227, M.O.321, M.O.544 and M.O.1030.

WORRALL, I. J., Lismore; C.H.93.

WRIGHT, W. H., Eaglehawk; U.T.380.

Notice of any objection should be forwarded to reach the Secretary of the Board not later than 15 October 1980.

Applicants are advised that it will not be necessary to appear on the hearing date specified, unless advised in writing by the Board.

C. J. V. SMITH, Secretary

Corner Lygon and Princes Streets, Carlton, 3053,  
 Wednesday, 1 October 1980

Commercial Goods Vehicles Act  
**TRANSPORT REGULATION BOARD**  
 HEARING OF APPLICATIONS

Notice is hereby given that the following applications will be considered by the Transport Regulation Board on 21 October 1980.

WILLIAMS ADAMS TRACTORS PTY. LTD., Nantilla Road, Clayton North, 3168. Four commercial goods vehicles (L/C. 0.75 tonne each) to operate throughout the State of Victoria in the course of business as "Distributor of Earthmoving and Industrial Equipment"—tools of trade, spare parts and materials incidental to the repair and servicing of earthmoving and industrial equipment in the field only.

ANDERSON, R. W., 15-17 Albert Street, Warrnambool, 3280. One commercial goods vehicle (L/C. 11.00 tonne) to operate within an 80-km radius of the post office at Warrnambool in the course of business as "Oil Agent"—petroleum products in prescribed types of containers and bulk tanks and empty farm storage tanks.

ASCOM EQUIPMENT PTY. LTD., 499 St. Kilda Road, Melbourne, 3004. One commercial goods vehicle (L/C. 13.16 tonne) to operate: (a) Within an 80-km radius of own premises at Clayton in the course of business as "Engineers and Constructors"—own goods excluding the carriage of restricted goods which may be specified

by notice in the *Government Gazette* from time to time. (b) Throughout the State of Victoria—tools of trade and equipment incidental only to own contracts. (c) Within a 40-km radius of the site of any contract currently engaged upon or from the railway station nearest thereto—own materials for use on such contract.

ASHTON, J. R., Sullivans Road, Strathfieldsaye, 3551. One commercial goods vehicle (L/C. 2.60 tonne) to operate: (a) From Auction Rooms throughout the State of Victoria to own premises at Bendigo—second-hand furniture. (b) Throughout the State of Victoria in the course of business as "Marine Collector"—marine goods as designated by the *Marine Stores and Old Metals Act 1958*, No. 6303 but excluding the carriage of any such goods to wharves, docks or ships for shipment or export purposes provided that the combined load capacity of the prime mover and any trailer attached thereto does not exceed 6.00 tonnes.

AUWEMA, M., Stobar R.S.D., Durmam Lead, 3352. One commercial goods vehicle (L/C. 1.00 tonne) to operate throughout the State of Victoria in the course of business as "Carpet and Linoleum Layer"—tools of trade and small quantities of carpet, linoleum and floor tiles for laying purposes only.

AVRAM HOLDINGS PTY. LTD., 56 Edward Street, Shepparton, 3630. One commercial goods vehicle (L/C. 24.25 tonne) to operate from Melbourne metropolitan area to own premises at Shepparton in course of business as "Hotelier"—beer, wine and spirits.

G. T. BURGESS & Co. PTY. LTD., P.O. Box 306, Warragul, 3820. One commercial goods vehicle (L/C. 8.15 tonne) to operate within a 120-km radius of the post office at Warragul excluding that area within a 40-km radius of the G.P.O. Melbourne in the course of own business as "Agricultural Machinery Sales and Service"—agricultural machinery and equipment for sale, demonstration, repair or having been repaired, spare parts, tools of trade and equipment incidental thereto.

C.R.A. EXPLORATION PTY. LTD., 54 Raglan Street, Preston, 3072. One commercial goods vehicle (L/C. 0.75 tonne) to operate throughout the State of Victoria in the course of business as "Mineral Exploration"—tools of trade, equipment and allied exploration materials and samples of minerals and earth excavated.

CASTLES MCGILTON PTY. LTD., corner William and Mason Streets, Warragul, 3820. Application to vary the conditions of licences numbered D.A.65838/6 and D.A.65838/8 by adding paragraphs (c) and (d) as follows: (c) From places within a 40-km radius of the G.P.O. Melbourne to own approved decentralized secondary industry (joinery) at Warragul—raw materials required for use in the manufacturing processes of such industry. (d) From own approved decentralized secondary industry premises at Warragul to places within an 80-km radius thereof and to Sale—goods having been manufactured at the said industry.

CRADDOCK, K. H., 2 Bronwyn Court, Clayton, 3168. One commercial goods vehicle (L/C. 10.90 tonne) to operate within a 112-km radius of the plant of Boral Resources (Vic.) Pty. Ltd. at Campbellfield solely on behalf of the said company—bricks.

DUNLOP AUSTRALIA LTD., 191 Lyttleton Terrace, Bendigo, 3550. One commercial goods vehicle (L/C. 0.50 tonne) to operate within an 80-km radius of own branch premises at Charlton in the course of business as "Tyre Retreaders and Distributors"—new tyres and tubes for delivery, used tyres and tubes for repair or having been repaired and also batteries, oil and motor car accessories and polythene piping.

DRUMMOND, G. E., 5 Carlisle Court, Frankston, 3199. One commercial goods vehicle (L/C. 0.65 tonne) to operate throughout the State of Victoria in the course of business as "Maintenance Engineer"—tools of trade, spare parts and materials required for on-site servicing and maintenance of forklifts and electrical equipment.

FIRE FIGHTING ENTERPRISES (AUST.) LTD., 203 Bouverie Street, Carlton, 3053. One commercial goods vehicle (L/C. 1.25 tonne) to operate throughout the State of Victoria in the course of business as "Fire Fighting Equipment Engineers" for the purpose of servicing fire fighting equipment—tools of trade, spare parts and

materials required for on-site servicing and maintenance of fire fighting equipment and fire alarm systems.

**FLAHERTY, J. M.**, 52 Kepler Street, Warrnambool, 3280. One commercial goods vehicle (L/C. 1.00 tonne) to operate in the course of business as "Confectionery Wholesaler" from Warrnambool to reseller whose premises are situated within that part of the State of Victoria bounded by on the west by the South Australian/Victorian border, on the north and east by the main road from Naracoorte (S.A.) via Edenhope and Natinuk to Horsham, thence by the Western Highway to Ballarat, thence by the main road through Cressy, Colac and Forrest to Apollo Bay and including all places within 8 km of such roads—confectionery, grocery lines, cordials and biscuits.

NOTE—All goods from Melbourne and Geelong area to be railed to Warrnambool or places within the above area.

**FLEET X PRESS PTY. LTD.**, 61 Bertie Street, Port Melbourne, 3207. One commercial goods vehicle (L/C. 19.10 tonne) to operate: (a) From the premises of motor vehicle distributors and dealers direct to consignees throughout the State of Victoria—complete motor vehicles, excluding tractors. (b) From the premises of motor vehicle manufacturers situated at Melbourne, Geelong and Dandenong direct to those wharves only where there are no rail facilities—motor car bodies.

**FLETCHER, R. S.**, Placadena Road, Rye, 3941. One commercial goods vehicle (L/C. 12.23 tonne) to operate within an 80-km radius of own premises at Rye in course of business as "Produce Merchant"—own goods excluding the carriage of restricted goods which may be specified by notice in the *Government Gazette* from time to time.

**GIBSON, D. P.**, 142 Princess Road, Corio, 3214. One commercial goods vehicle (L/C. 0.50 tonne) to operate: (a) Within a 40-km radius of the chief post office in the City of Geelong—general goods. (b) Within an 80-km radius of the chief post office in the City of Geelong in the course of business as "Electrical Serviceman"—television sets, radios and electrical appliances for installation, repair or having been repaired and also tools of trade and materials incidental to the installation, servicing and maintenance of such appliances.

**GREENWAYS REFRIGERATED TRANSPORT (VIC.) PTY. LTD.**, Grant Road, Somerville, 3912. One commercial goods vehicle (L/C. 1.45 tonne) to operate throughout the State of Victoria in the course of business as "Frozen Food Distributors" for the purpose of servicing and maintaining own vehicles—tools of trade, spare parts and materials incidental to the servicing and maintenance of own vehicles in the field only.

**MAYNE NICKLESS LTD.**, 390 St. Kilda Road, Melbourne, 3004. One commercial goods vehicle (L/C. 2.00 tonne) to operate throughout the State of Victoria in the course of business as "Armoured Escort" as an armoured vehicle for the purpose of making special deliveries.

**MEBAM EQUIPMENT PTY. LTD.**, 881 Princes Highway, Springvale, 3171. One commercial goods vehicle (L/C. 1.10 tonne) to operate throughout the State of Victoria in the course of business as "Manufacturers and Distributors of Materials Handling Equipment" for the purpose of servicing materials handling equipment—tools of trade, spare parts and materials incidental to on-site servicing.

**L. J. MORGAN PTY. LTD.**, 105 Newland Road, Coburg, 3058. One commercial goods vehicle (L/C. 3.35 tonne) to operate: (a) Within an 80-km radius from own premises at Coburg in the course of business as "Hardware Manufacturers"—own goods. (b) (i) From own factory at Coburg to the premises of associate company John McIlwraith Industries Ltd. at Castlemaine an approved decentralized secondary industry (polishing and fabrication of plumbers hardware)—semi processed wash trough bowls. (ii) From the said decentralized industry at Castlemaine to own premises at Coburg—partly completed bowls and accessories. (c) Between own premises at Coburg and

premises of associate company John McIlwraith Industries Ltd. at Castlemaine—tools of trade, also machinery and equipment for repair or having been repaired together with spare parts required for on-site servicing and maintenance only.

**RICHARDS, I.**, Gormandale, 3873. One commercial goods vehicle (L/C. 20.00 tonne) to operate from forest landings situated within a 16-km radius of the Post Office at Licola to the premises of A.P.M. Ltd. at Maryvale—pulpwood.

**ROBERTSON, L. J.**, 18 Vistula Avenue, North Geelong, 3215. One commercial goods vehicle (L/C. 2.00 tonne) to operate within an 80-km radius from the chief post office in the City of Geelong in the course of business as "Refrigeration Engineer" for the purpose of servicing and installing refrigeration equipment—tools of trade, materials incidental to such servicing and installation and refrigeration equipment for repair or having been repaired.

**TAYLOR, A.**, 155 Thompsons Road, Bulleen, 3105. One commercial goods vehicle (L/C. 1.50 tonne) to operate throughout the State of Victoria in the course of business as "Wrestling Entrepreneur"—tools of trade, own equipment and wrestling equipment and rings for removal from site to site.

**TUBEMAKERS OF AUST. LTD.**, corner Barwon Heads Road and Breakwater Road, Belmont, 3216. One commercial goods vehicle (L/C. 7.70 tonne) to operate: (a) Within a 40-km radius of the chief post office at Geelong in the course of business as "Steel Supplies"—own goods. (b) From and to places within a 40-km radius of the G.P.O., Melbourne to and from own premises at Belmont—own goods (other than restricted goods which may be specified by notice in the *Government Gazette* from time to time).

NOTE—Nothing contained in paragraph (b) shall be deemed to authorise any goods taken up within 40-km radius of the G.P.O., Melbourne to be carried to or set down at any point beyond the company's own premises at Belmont.

**TULLOCH PETROLEUM SERVICES PTY. LTD.**, 3149 Lioneli Road, Mount Waverley, 3149. Three commercial goods vehicles (L/C. 0.95, 2.25, 1.90 tonne) to operate throughout the State of Victoria in the course of business as "Petroleum Dispensing Equipment Installation Contractor" for the purpose of servicing and installing petroleum dispensing equipment—tools of trade, spare parts incidental to servicing and excavation and dispensing equipment for specialised installations.

**WRIGHT, C. A.**, 13 Cliff Road, Shoreham, 3916. One commercial goods vehicle (L/C. 11.25 tonne) to operate within an 80-km radius of own premises at Shoreham in the course of business as "Sawmillers"—own goods excluding the carriage of restricted goods from a 13-km radius of the chief post office in Geelong.

**T. & U. ZURCAS HOLDINGS PTY. LTD.**, Doyles Road, Shepparton, 3630. One commercial goods vehicle (L/C. 11.45 tonne) to operate from Melbourne metropolitan area to own premises at Shepparton in course of business as "Hotelier"—beer, wine and spirits.

**ZURCAS, M.**, Grahamvale Road, Grahamvale, 3631. One commercial goods vehicle (L/C. 11.15 tonne) to operate from Melbourne metropolitan area to own premises at Shepparton in course of business as "Hotelier"—beer, wine and spirits.

#### TOW TRUCK

**HOLLOWAY, K.**, 7 Perkin Court, Dandenong, 3175. One commercial goods vehicle (L/C. 1.30 tonne) to operate: (a) Within an 80-km radius of own premises at Dandenong as a "Tray Body Tow Truck" fitted with vehicle ramps and winch for the purpose of lifting and carrying or towing and/or repairing wrecked or disabled motor vehicles.

NOTE—Excluding the ability to attend the scene of any motor vehicle accident whatsoever.

(b) Throughout the State of Victoria for the purpose of transporting own racing car to or from motor car races.

## RENEWALS

Applications for renewal of licences as shown by persons listed hereunder to operate under the same terms and conditions from the expiry shown in each case.

- WILLIAM ADAMS TRACTORS PTY. LTD., Nantilla Road, Clayton, 3168; D.A.512/39; 1 December 1980; 1.85 tonne; D.A.512/41; 14 December 1980; 0.45 tonne.
- ATTARD, A., 83 Taunton Drive, Cheltenham, 3192; D.A.67002; 5 December 1980; 0.70 tonne.
- BAGLIN, I. W., 2 Sussex Street, Blackburn, 3130; D.A.62271; 29 October 1980; 0.50 tonne.
- BEAUREPAIRE TYRE SERVICE PTY. LTD., 83 Franklin Street, Melbourne, 3000; D.A.629/94; 8 December 1980; 1.25 tonne; D.A.629/96; 8 December 1980; 1.40 tonne; D.A.629/112; 21 December 1980; 2.60 tonne.
- BENHAM, D. L. & R. A., Church Road, Bellarine, 3221; D.A.69019; 21 December 1980; 11.05 tonne.
- BRAMBLES HOLDINGS LTD., Arden and Lothian Streets, North Melbourne, 3051; D.A.63215/1; 4 December 1980; 2.35 tonne.
- DICKESON, S. J., 16 Officer Street, Hamilton, 3300; D.A.60607/11; 18 November 1980; 0.75 tonne; D.A.60607/8; 18 November 1980; 0.75 tonne; D.A.60607/9; 18 November 1980; 0.75 tonne; D.A.60607/10; 18 November 1980; 0.75 tonne.
- ALBERT H. FOX PTY. LTD., 16 Warragul Shopping Plaza, Warragul, 3820; D.A.33038/5; 1 December 1980; 0.75 tonne.
- J. C. HUTTON PTY. LTD., 60 Oakover Road, Preston, 3072; D.A.48355/31; 1 December 1980; 1.75 tonne.
- W. T. JONES & SON, 11 Piper Street, Kyneton, 3444; D.A.1404; 1 December 1980; 5.60 tonne.
- KEATING, B. P., 31 Bay Street, Golden Square, 3555; D.A.68189; 1 December 1980; 3.80 tonne.
- LANG, A. R., Morris Street, Maldon, 3463; D.A.68914; 7 October 1980; 6.70 tonne.
- MAIN, F., 65 Humphrey Street, Ballarat, 3350; D.A.69014; 16 December 1980; 3.40 tonne.
- MOLECTRON PTY. LTD., 79 St. Georges Road, Norlane, 3214; D.A.68876; 5 December 1980; 3.05 tonne.
- E. E. MUIR & SONS PTY. LTD., 542 Footscray Road, Footscray, 3011; D.A.53927; 7 December 1980; 7.60 tonne.
- MCDONALD, J. R., "Jingella", Yeodene, 3249; D.A.53939; 8 December 1980; 16.75 tonne.
- MCKENZIE'S TRANSPORT & AGENCY, 53 Barkers Road, Kew, 3101; D.A.1689/1; 23 December 1980; 9.80 tonne.
- PRYOR, J., 226 Dawson Street, Ballarat, 3350; D.A.65746; 11 December 1980; 0.70 tonne; D.A.65746/1; 11 December 1980; 0.75 tonne.
- STEWART, D. T., 5 Railway Crescent, Korumburra, 3950; D.A.69022; 21 December 1980; 3.05 tonne.
- WHITELAW ROOFING TILES PTY. LTD., Elliott Road, Dandenong, 3175; D.A.65425/4; 4 December 1980; 1.35 tonne; D.A.65425/5; 4 December 1980; 1.35 tonne.

## TOW TRUCK

- WHITING, J. A., 7 Raven Grove, Werribee, 3030; D.A.68240/1; 12 December 1980; 3.35 tonne.

Notice of any objection should be forwarded to reach the Secretary of the Board not later than 15 October 1980.

Applicants are advised that it will not be necessary to appear on the hearing date specified above, unless advised in writing by the Board.

C. J. V. SMITH, Secretary

Corner Lygon and Princes Streets, Carlton, 3053, Wednesday, 1 October 1980

## PUBLIC TRUSTEE ACT 1958, SECTION 17

I hereby give notice that on 19 September 1980, the Public Trustee filed Elections to Administer the following deceased person's estates in accordance with section 17 of the Public Trustee Act 1958.

BOEHM, KEITH ALLAN, also known as Keith Alan Boehm, late of Flat 3/68 Barkers Road, Hawthorn, chef, died on 24 March 1980.

CARRICK, LILLIAN DOROTHY, late of 344 Dandenong Road, East St. Kilda, spinster, died on 16 January 1980.

DONALDSON, JAMES WILLIAM, late of 382 Carlisle Street, St. Kilda, pensioner, died on 20 May 1980.

MURPHY, JOHN BAPTIST, late of Miami Private Hotel, 13 Hawke Street, West Melbourne, carpenter, died on 19 July 1980.

WEBB, GRACE ARLETTA, late of Flat 8/12 De Murska Street, Windsor, widow, died on 4 August 1980.

P. T. SPENCER  
Public Trustee

168 Exhibition Street, Melbourne, Vic., 3000  
24 September 1980

Creditors, next of kin, and others having claims against the estate of any of the under-mentioned deceased persons are required to send particulars of their claims to the Public Trustee, 168 Exhibition Street, Melbourne, Vic. 3000, the personal representative, on or before 8 December 1980 after which date the Public Trustee may convey or distribute the assets having regard only to the claims of which the Public Trustee then has notice:—

BOEHM, KEITH ALLAN, also known as Keith Alan Boehm, late of Flat 3/68 Barkers Road, Hawthorn, chef, died on 24 March 1980.

CALDECOTT, HAROLD LEONARD, late of 108A Roberts Street, Essendon, retired real estate agent, died on 14 June 1980.

CARRICK, LILLIAN DOROTHY, late of 344 Dandenong Road, East St. Kilda, spinster, died on 16 January 1980.

DONALDSON, JAMES WILLIAM, late of 382 Carlisle Street, St. Kilda, pensioner, died on 20 May 1980.

FERO, FLORA ANNABELLE, also known as Flora Annabella Fero, late of 7 Rona Street, Reservoir, widow, died on 25 July 1980.

HOWELL, ENID MANSFIELD, late of 29 Tennyson Street, Sandringham, spinster, died on 3 May 1980.

MCMANARA, AMY, late of 179 Albion Street, East Brunswick, widow, died on 1 July 1980.

MURPHY, JOHN BAPTIST, late of Miami Private Hotel, 13 Hawke Street, West Melbourne, carpenter, died on 19 July 1980.

ORR, PATRICK ARMER, late of Upper Hutt, New Zealand, retired technician, died on 4 January 1980.

ROBINSON, JOHN CUTHBERT, formerly of 11 Station Street, Kew, but late of 67 Hartington Street, Kew, retired cleaner, died on 11 July 1980.

VANAGS, MILDA DOROTEA, late of 88 Mitchell Street, Wodonga, widow, died on 19 May 1980.

WEBB, GRACE ARLETTA, late of Flat 8/12 De Murska Street, Windsor, widow, died on 4 August 1980.

WEIR, FLORENCE OLIVE, also known as Florence Weir, late of 45 Jacka Street, Macleod West, widow, died on 10 June 1980.

WILLIAMS, JOHN STANLEY, also known as John Williams, late of Kenilworth Private Hospital, 3 Kenilworth Parade, Ivanhoe, gentleman, died on 26 July 1980.

WINKLER, KONRAD, formerly of 14 Byron Street, Footscray, late of 29 Simpson Street, East Melbourne, pensioner, died on 7 July 1980.

YOUNGER, THOMAS KEITH, late of Flat 1/6 Nelson Street, Rye, retired, died on 8 June 1980.

Melbourne, 24 September 1980

P. T. SPENCER  
Public Trustee

*Private Agents Act 1966*

## NOTICE OF RECEIPT OF APPLICATIONS FOR LICENCES UNDER THE PROVISIONS OF THE PRIVATE AGENTS ACT 1966

The Clerk(s) of the Magistrates' Court(s) as listed hereunder hereby give notice that applications, as under, have been lodged for hearing by the said Court(s) on the date(s) specified.

Any person desiring to object to any of such applications must—

- (a) lodge with the respective Clerk of the Magistrates' Court a notice in the prescribed form of his objection and of the grounds thereof;
- (b) cause a copy of such notice to be served personally or by post upon the applicant at least three days before the hearing of the application; and
- (c) send or deliver—
  - (i) where the objection is not made by the officer in charge of the police district in which the Court is situated—a copy of the notice to such officer; and
  - (ii) where the objection is not made by the Registrar or Deputy Registrar—a copy to the Registrar.

Full Name of Applicant*	Place of Abode of Applicant or Nominee	Name of Firm or Corporation	Address for Registration	Type of Licence	Date of Hearing
<b>MAGISTRATES' COURT, COBURG</b>					
Hale, Ronald Anthony	105 Narina Way, Epping		38 Alice Street, Coburg	Watchman	27.10.80
Dated at Coburg 19 September 1980 J. F. ISAACS, Clerk of the Magistrates' Court					
<b>MAGISTRATES' COURT, MELBOURNE</b>					
Fuller, William James	121 Wairora Rd, West Heidelberg		213 Arden St, North Melbourne	Watchman	28.10.80
Standaar, Christiaan Heinrich Christoph	28 Webster Cres, Watsonia		" "	" "	" "
Dated at Melbourne 18 September 1980 M. J. QUIRK, Clerk of the Magistrates' Court					
<b>MAGISTRATES' COURT, MELBOURNE</b>					
Borowski, Howard Ostoe	46 Service St, Hampton		Cnr. Arden and Lothian Sts, North Melbourne	Watchman	28.10.80
Gill, Peter John	75 Latham St, East Bentleigh		" "	" "	" "
Wooding, John Willard	3 Hyslop St, Werribee		" "	" "	" "
Hopkins, Alan Ralph	1/424 Glenferrie Rd, Kooyong	Australian Bullion Company Pty. Ltd.	461 Bourke St, Melbourne	Guard Agent	" "
Dated at Melbourne 19 September 1980 M. J. QUIRK, Clerk of the Magistrates' Court					
<b>MAGISTRATES' COURT, PORT MELBOURNE</b>					
Blake, Patrick	Main St, Nyah	Mayne Nickless Ltd.	390 St. Kilda Rd, Melbourne	Watchman	6.11.80
Dated at Port Melbourne 19 September 1980 S. MERBACK, Clerk of the Magistrates' Court					
<b>MAGISTRATES' COURT, RINGWOOD</b>					
McCurdy, Annette Margaret	6 Ensay Crt, Vermont South		6 Ensay Crt, Vermont South	Commercial Agents	10.10.80
Dated at Ringwood 19 September 1980 L. T. GOULD, Clerk of the Magistrates' Court					
<b>MAGISTRATES' COURT, ST. ARNAUD</b>					
Burnham, Barry Arthur	35 North Western Rd, St Arnaud	Northern Central Security Service	13 Alma St, St Arnaud	Guard Agent	21.10.80
Dated at St. Arnaud 19 September 1980 Clerk of the Magistrates' Court					
<b>MAGISTRATES' COURT, SPRINGVALE</b>					
Van Dyke, Robert	Unit 3/19 Elder St, Clarinda		94 York St, South Melbourne	Watchman	10.10.80
Dated at Springvale 19 September 1980 A. R. TYERS, Clerk of the Magistrates' Court					

\* Or in the case of a firm or corporation, of the Nominee

## PRIVATE AGENTS—continued

Full Name of Applicant*	Place of Abode of Applicant or Nominee	Name of Firm or Corporation	Address for Registration	Type of Licence	Date of Hearing
<b>MAGISTRATES' COURT, BENDIGO</b>					
Jackman, Linton Henry	53 Mill St, Bendigo	Bendigo Investments Limited	Abel St, Bendigo	Guard Agent	20.10.80
Dated at Bendigo 25 September 1980 K. T. RYAN, Clerk of the Magistrates' Court					
<b>MAGISTRATES' COURT, MELBOURNE</b>					
Lowan, Graham Roy	4 Hazel Ave, Thomastown		Cr. Arden and Lothian Streets, North Melbourne	Watchman	28.10.80
Jacobson, Gary William	59 McIntosh St, Airport West		" "	"	"
Merriel, Jeffrey William	54 Churinga Ave, Mitcham		" "	"	"
Dated at Melbourne 22 September 1980 M. J. QUIRK, Clerk of the Magistrates' Court					
<b>MAGISTRATES' COURT, SWAN HILL</b>					
Mudge, Trevor Michael	Ultima Rd, Culgoa		10 Harrison Cres, Swan Hill	Watchman	29.10.80
Dated at Swan Hill 24 September 1980 P. J. O'GRADY, Clerk of the Magistrates' Court					
<b>MAGISTRATES' COURT, MARYBOROUGH</b>					
Hartley Peter James	37 Peel St, Maryborough		37 Peel St, Maryborough	Process Server	16.10.80
" " "	" "		" "	Inquiry Agent	"
Dated at Maryborough 24 September 1980 R. A. ISON, Clerk of the Magistrates' Court					
<b>MAGISTRATES' COURT, YARRAM</b>					
Dawson, Ian Alexander	Alberton	Wormald International Security	340 Abbotsford St, North Melbourne	Watchman	7.11.80
Dated at Yarram 25 September 1980 J. W. KEE, Clerk of the Magistrates' Court					
<b>MAGISTRATES' COURT, RINGWOOD</b>					
Knight and Borcich	2 Ellison St, Ringwood	Knight and Borcich	2 Ellison St, Ringwood	Process Server	17.10.80
Knight, Gavan Christopher	" "	" "	" "	Inquiry Agent	"
Dated at Ringwood 24 September 1980 L. T. GOULD, Clerk of the Magistrates' Court					

\* Or in the case of a firm or corporation, of the Nominee

## AUCTION SALES ACT 1958

**BALLARAT**—Notice is hereby given that the Annual Meeting of Justices for the Licensing of Auctioneers will be held at the Magistrates' Court, Ballarat, on Tuesday, 25 November 1980, at 10 o'clock in the forenoon. Dated at Ballarat, 22 September 1980—D. L. CROFT, Clerk of the Magistrates' Court, Ballarat.

**CASTERTON**—Notice is hereby given that the Annual Meeting for the Licensing of Auctioneers in the Casterton area will be held at the Casterton Law Courts on Tuesday, 25 November 1980 at 10 o'clock in the forenoon—M. J. SIMPSON, Clerk of Courts, Casterton.

**CASTLEMAINE**—Notice is hereby given that the Annual Meeting of Justices for the Licensing of Auctioneers will be held at the Magistrates' Court at Castlemaine on

Tuesday, 25 November 1980 at 10 o'clock in the forenoon. Dated at Castlemaine, 12 September 1980—P. J. CRAWFORD, Clerk of the Magistrates' Court, Castlemaine.

**HAMILTON**—Notice is hereby given that the Annual Meeting for the Licensing of Auctioneers in the Hamilton area will be held at the Hamilton Law Courts on Tuesday, 25 November 1980 at 10.00 a.m.—B. F. DOCKING, Clerk of Courts, Hamilton.

**SWAN HILL**—Notice is hereby given that the Annual Meeting of Justices for the Licensing of Auctioneers will be held at Magistrates' Court, Swan Hill, on Tuesday, 25 November 1980 at 10 o'clock in the forenoon. Dated at Swan Hill, 25 September 1980—P. J. O'GRADY, Clerk of the Magistrates' Court, Swan Hill.

STATE RIVERS AND WATER SUPPLY COMMISSION  
 NOTICE OF INTENTION TO DECLARE FLOOD PRONE AREA—SALE

Pursuant to Section 35 of the *Drainage of Land Act 1975*, the State Rivers and Water Supply Commission as the Drainage Authority, proposes on or after 12 November 1980 to request the Governor in Council to proclaim as liable to flooding that land at Sale below the 1 per cent probability flood level as detailed on Plan No. 132641 hereunder, the original of which is available for inspection at—

- (1) The offices of the State Rivers and Water Supply Commission at:  
 590 Orrong Road, Armadale; and Pearson Street, Maffra.
- (2) The Municipal Offices of the Shire of Rosedale.

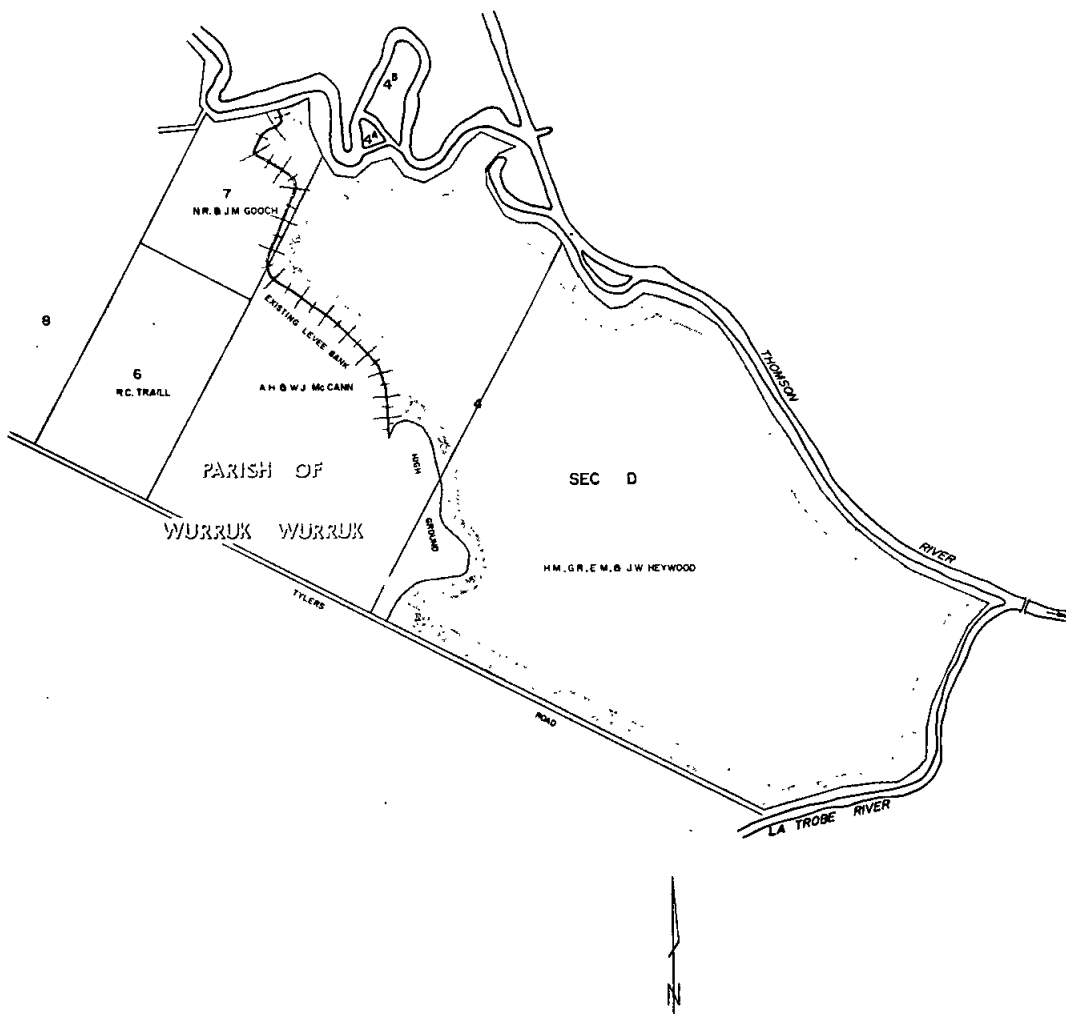

Any objections to the making of this proclamation lodged at the above offices within six weeks of this notice will be considered by the State Rivers and Water Supply Commission before any recommendation is made to the Governor in Council—(Corres. No. 80/2894).

Dated 1 October 1980

R. BIRD, Secretary



*National Parks Act 1978*  
**MOUNT WORTH STATE PARK—MORWELL NATIONAL PARK**  
 MINISTERIAL DECLARATION

In pursuance of the provisions of section 10 (1) of the *National Parks Act 1978*, No. 9247, I William Vasey Houghton, Her Majesty's Minister for Conservation in the State of Victoria hereby declare that as and from the date of this notice—

- (i) The following land is included in Mount Worth State Park—Allotment 61A and part allotments 17B, 21, 61B and 61C, Parish of Allambee comprising 178 ha ±.
- (ii) The following land is included in Morwell National Park—Allotments 3 and 3A, section A and part allotment 8, section A, Parish of Yinnar, comprising 170 ha ±.
- (iii) The following land is deemed to be reserved forest within the meaning of the *Forest Act 1958*—Part allotment 8, section A, Parish of Yinnar, comprising 27 ha and being the land indicated on the plan below.

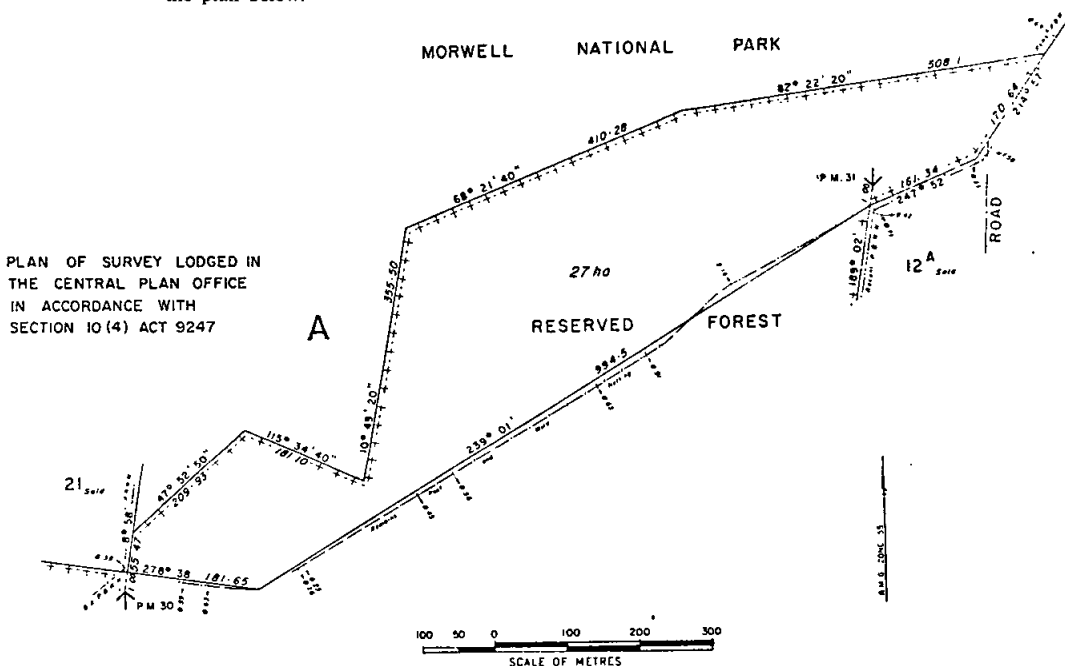

The land referred to in items (i) and (ii) is more particularly defined in the Third Schedule of Act No. 9247.

W. V. HOUGHTON  
 Minister for Conservation

*Urban Renewal Act 1970*  
**CITY OF WARRNAMBOOL**  
 (LIEBIG STREET)  
 URBAN RENEWAL PROPOSAL  
*Housing Commission, Victoria*

Notice of Modification to Proposal pursuant to Section 5 (13) of the Act.

Whereas the renewal authority has considered objections and submissions and has adopted the proposal with modifications and alterations; and whereas in the opinion of the Minister of Housing the modifications and alterations are of a substantial nature as to warrant the depositing of the proposal for public inspection and affording an opportunity for any person affected thereby to notify the Minister of any objections in writing thereto.

It is hereby notified that the adopted proposal will be on exhibition from 1 October 1980 to 10 November 1980 at the offices of the Town and Country Planning Board, 235 Queen Street, Melbourne; the City of Warrnambool, Liebig Street, Warrnambool; and the Housing Commission, Victoria, 10th Floor, 250 Elizabeth Street, Melbourne during office hours for inspection by any person free of charge.

Any person affected by this modified proposal may notify the Minister in writing of any objections thereto on or before 10 November 1980.

N. GREEN, Manager  
 Administration

*Friendly Societies Act 1958*  
**ADVERTISEMENT OF DISSOLUTION BY INSTRUMENT**

Notice is hereby given that the society known as the Ararat and District United Friendly Societies' Dispensary, register number 2731, held at Melbourne, is dissolved by instrument registered at this office the 12 September 1980 unless within three months from the date of the *Government Gazette* in which this advertisement appears proceedings be commenced by some member or other person interested in or having any claim on the funds of the society, to set aside such dissolution, and the same be set aside accordingly.

Dated 12 September 1980

D. J. WATT  
 Registrar of Friendly Societies

CONTRACTS ACCEPTED—(Series 1980-81)				AMENDMENTS—continued			
AMENDMENTS				Schedule Number	Item Number	New Rate	Effective Date
Schedule Number	Item Number	New Rate	Effective Date				
<b>Electrical Goods</b>							
1/05	67	Eveready Trade List 1.7.80 Less 20.5%	26.8.80	1/35	1	Elders Metals Ltd. Steel Price List 19.8.80	25.8.80
	68	Eveready Trade List 4.2.80 Less 20.5%	13.6.80		3	Per Tonne Less 16% Elders Metals Ltd. List 19.8.80 Less 25%	
	69	Eveready Trade List 1.7.80 Less 20.5%	26.8.80				
	70	Clipsal List 18.8.80 Less 21.6%					
	70	H.P.M. Trade List 1.9.80 Less 21.6%	4.9.80				
	72	Ring Grip Trade List 25.8.80 Less 21.6%	26.8.80				
	73	Thomson & Scougall Trade List 18.8.80 Less 18.5%					
		Clipsal List 18.8.80 Less 25.5%					
<b>Fire Protection Equipment, Fire Extinguishers etc.</b>							
1/06	14	58.90†	2.9.80				
	15	68.20†					
	16	48.05†					
	17	135.63†					
		† Less 1%, 30 days.					
<b>Glass</b>							
1/07	23	14.77†	1.9.80				
		† Less 1%, 30 days.					
<b>Industrial Gases (In Cylinders)</b>							
1/10	1	2.16	1.10.80				
	2	2.16					
	4	0.35					
	5	0.35					
<b>Delivery (Metropolitan Area Only)—</b>							
The Commonwealth Industrial Gases Limited Ex Preston Works—							
"G" and "E" Size Cylinders \$1.65 each.							
"D" Size Cylinders \$0.90 each.							
Minimum Charge Unchanged.							
<b>Protective Clothing, Uniforms and Safety Equipment</b>							
1/14	1, 3	11.53	4.9.80				
	1, 3	11.81	11.9.80				
	4-7	10.86*	8.9.80				
	8-11	13.74*					
	13	11.37	4.9.80				
	13	11.65	11.9.80				
	15	12.82	4.9.80				
	15	13.13	11.9.80				
	16	11.74	4.9.80				
	16	12.03	11.9.80				
	18	8.47	4.9.80				
	18	8.68	11.9.80				
	19	0.70	4.9.80				
	19	0.72	11.9.80				
		* Less 2½% Settlement Discount, 30 days.					
<b>Soaps and Soap Mixtures</b>							
1/15	21	12.80†	22.9.80				
		†Minimum Order 6 Case Total.					
<b>Piping and Fittings</b>							
1/34	6, 7	List 21.8.80* Less 15%	22.8.80				
		* Crane Enfield Metals Pty. Limited.					
				<b>Steel (Mild)</b>			
				\$			
				<b>Motor Spirit (Bulk)—State Petrol Centre</b>			
				1/53A	1	0.2894	29.8.80
					2	0.2972	12.8.80
				<b>Motor Spirit, Kerosene, Fuel Oils and Lubricants</b>			
				1/53B	3	0.2924	29.8.80
					4	0.2958	
					5	0.3044*	
					6	0.3044*	
					7	0.3025	
					8	0.3059	
					9	0.3145*	
					10	0.3145*	
					11	0.2994	
					12	0.3164‡	
					13	0.2994	
					14	0.3164‡	
					15	0.3095	
					16	0.3265‡	
					17	0.3095	
					18	0.3265‡	
					20	0.3540*	
					27	0.2374*	
					29	0.2670*	
					31	190.52*	
				* Supply Conditions Unchanged.			
				‡ The Shell Co. of Australia Ltd.			
				<b>Hand Tools (General)</b>			
				1/56	4	1.41	2.9.80
					59	*	16.9.80
					308	2.81	1.9.80
					352	1.09	29.8.80
					353	1.09	
					359	3.21	
					360	3.36	
					361	3.50	
					362	3.77	
					461	3.57	15.9.80
				*Change Contractors Address to 77-91 Ricketts Road, Mount Waverley. Telephone 543 5655.			
				<b>Tyres and Tubes, Pneumatic</b>			
				1/57	1c	Goodyear List No. T52 Less 68%*	18.7.80
				* Less 2½%, 30 days.			
				<b>Stationery, General</b>			
				1/64	108	14.12	28.5.80
				<b>Groceries—Melbourne and Metropolitan District</b>			
				2/02	4	3.23	1.9.80
					6	5.04	
					16	6.33	
					16A	5.36	
					18	9.28	
					19	9.82	
					20	9.82	
					21	8.66	
					22	9.76 per 10 kg	
					24	4.99	
					25	8.51	
					25A	7.71	
					48	18.33 per 6	

AMENDMENTS—continued				AMENDMENTS—continued			
Schedule Number	Item Number	New Rate	Effective Date	Schedule Number	Item Number	New Rate	Effective Date
\$				\$			
Groceries—Melbourne and Metropolitan District—continued				Provisions—Butter			
2/02	57	2.08	1.9.80	2/03	9	42.00	5.9.80
	71	1.76 per 3			10	27.90	
	81	5.62 per 6			11	42.00	
	103	2.82 per 6			12	27.90	
	107	6.09			13	41.74	
	125	8.59 per 12			21	42.00	
	126	16.62			22	27.90	
	127	8.04 per 12		Provisions—Cheese			
	128	15.57		2/04	13A	2.32	5.9.80
	129	8.04 per 12			13	2.16	
	130	15.57			14A	2.16	
	136	8.04 per 12		Provisions—Agricultural College Glenormiston			
	137	15.57		2/14 (1)	1	0.4757	8.9.80
	138	11.58			3	0.5157	
	139	10.96			5	1.0552	
	140	10.96			6	17.49	
	144	2.82			7	6.92	
	155	5.11		Provisions—Anglesea Recreation Camp			
	156	15.01		2/28 (2)	2	0.82	15.7.80
	157	2.72		Cartage and Delivery of Goods and Parcels			
	162	7.46		4/05		0.757	13.10.80
	164	7.46		J. M. PAWSON, Secretary to the Tender Board			
	166	7.92					
	167	7.92					
	181	4.94					
	182	4.53					
	202	2.22					
	203	4.02					
	206	2.85					
	207	1.91 per 6					
	211	5.56					
	225	1.95					
	249	3.71					
	253	3.14 per 6					
	254	5.23					
	255	30.40					
	259	12.51					

**CONTRACTS ACCEPTED—(Series 1980-81)**  
**PUBLIC WORKS**

His Excellency the Governor of the State of Victoria, by and with the advice of the Executive Council thereof, has by Orders made on 23 September 1980, approved of the acceptance by the Minister of Public Works of the under-mentioned offers without public tenders being invited, viz.:

Offer of John Moriarty for Professional Services (Architect) at Warragul Primary School for the sum of Seventeen thousand dollars (\$17 000)—(E.18640 "P").

Offer of Jennings Industries Ltd. for Erection of New School Building at Kismet Park Primary School for the sum of Nineteen thousand one hundred and forty-one dollars and forty-one cents (\$19 141.41)—(W.78134).

Offer of Avalon Engineering Industries Pty. Ltd. for Fire Reinstatement at Fawcner Technical School for the sum of Thirty thousand two hundred and ninety-one dollars eighty cents (\$30 291.80)—(C.192554).

Offer of Guardian Property Service for maintenance cleaning for period 15 September 1980 to 30 September 1983 at the Police Hospital, Dodds Street, South Melbourne, for the sum of Twenty-three thousand one hundred and five dollars three cents (\$23 105.03) per annum—(P.8069).

TOM FORRISTAL  
Clerk of the Executive Council

At the Executive Council Chamber  
Melbourne, 23 September 1980

VICTORIA  
**ACT 391—SECOND SCHEDULE**

A statement of trusts having been submitted by the head or authorised representative of the denomination known as The Roman Catholic Church for the Diocese of Ballarat pursuant to the provisions of the Act to provide for the abolition of State Aid to Religion for allowance of His Excellency the Governor (the same was allowed by him on 23 September 1980) and the following is the form in which such statement of trusts has been allowed.

STATEMENT OF TRUSTS

*Description of Land*—Site set apart for Roman Catholic Church purposes; 8096 square metres, Township of Sheldford, Parish of Doroo, being Crown allotment 1, section 11. Commencing at the north-eastern angle of Crown allotment 1A, section 11; bounded thence by that allotment bearing 270 deg. 00 min. 99.38 metres, by Tolson Street bearing 0 deg. 00 min. 81.47 metres, by Mercer Street bearing 90 deg. 00 min. 99.38 metres and thence by Thomson Street bearing 180 deg. 00 min. 81.47 metres to the point of commencement—(Rs.10575).

*Names of Trustees*—The Roman Catholic Trusts Corporation of 9 Lyons Street South, Ballarat.

*Powers of Disposition*—Such powers of disposition including powers of sale, lease or mortgage as are contained in *The Roman Catholic Trusts Act 1907*.

*Purposes to which Proceeds of Disposition are to be Applied*—To such Roman Catholic Church purposes as shall be approved by the Trustees or a majority thereof.

As witness the hand of the Governor of the State of Victoria, 23 September 1980—

HENRY WINNEKE  
Governor of the State of Victoria

## VICTORIA

## ACT 391—SECOND SCHEDULE

A statement of trusts having been submitted by the head or authorised representative of the denomination known as the Church of England in the Diocese of Wangaratta in Victoria, pursuant to the provisions of the Act to provide for the abolition of State Aid to Religion, for allowance of His Excellency the Governor (the same was allowed by him on 23 September 1980) and the following is the form in which such statement of trusts has been allowed.

## STATEMENT OF TRUSTS

*Description of Land*—Site set apart for Church of England purposes, 8094 square metres, Township of Pyalong, Parish of Pyalong, being Crown allotment 1A, section 5. Commencing at the north-western corner of Crown allotment 3, section 5; bounded thence by that allotment bearing 174 deg. 00 min. 100.58 metres; by a road bearing 264 deg. 00 min. 80.47 metres; by a line bearing 354 deg. 00 min. 100.58 metres; and thence by Bridge Street bearing 84 deg. 00 min. 80.47 metres to the point of commencement—(L.6-1628).

*Name of Trustee*—The Church of England Trusts Corporation for the Diocese of Wangaratta of Wangaratta aforesaid.

*Power of Disposition*—Power to sell lease mortgage or exchange all or any part of such land subject to the approval of the Bishop of Wangaratta for the time being or during the absence of the Bishop from the Diocese or the vacancy of the See to the approval of the person for the time being administering the affairs thereof. The land until otherwise disposed of to be held for the purpose for which it was granted or reserved by the Crown.

*Purposes to which Proceeds of Disposition are to be Applied*—To such purposes of the Church of England as may be agreed upon by—

- (1) The Bishop or during his absence from his See or during the vacancy thereof by the person or persons for the time being administering the affairs of the Diocese.
- (2) The Trustees of the Church of England Trusts Corporation for the Diocese of Wangaratta.
- (3) The Minister entitled to occupy the aforesaid land.

As witness the hand of the Governor of the State of Victoria, 23 September 1980—

HENRY WINNEKE  
Governor of the State of Victoria

## VICTORIA

## ACT 391—SECOND SCHEDULE

A statement of trusts having been submitted by the head or authorised representative of the denomination known as The Uniting Church in Australia pursuant to the provisions of the Act to provide for the abolition of State Aid to Religion, for allowance of His Excellency the Governor (the same was allowed by him on 23 September 1980) and the following is the form in which such statement of trusts has been allowed.

## STATEMENT OF TRUSTS

*Description of Land*—Site for Presbyterian Church purposes temporarily reserved by Order in Council of 14 May 1866 (see *Government Gazette* 1866, page 1114). 5781 square metres, Parish of Woornyalook, being Crown allotment 2c, section 11. Commencing at the north-eastern angle of Crown allotment 2A, section 11; bounded thence by roads bearing 96 deg. 27 min. 30 sec. 76.04 metres and 186 deg. 23 min. 30 sec. 37.86 metres; by Crown allotment 3a bearing 231 deg. 23 min. 30 sec. 107.72 metres, and thence by Crown allotment 2A bearing 6 deg. 27 min. 30 sec. 114.12 metres to the point of commencement—(C.74240).

*Names of Trustees*—The Uniting Church in Australia Property Trust (Victoria).

*Powers of Disposition*—Such powers of disposition including the powers to mortgage sell lease exchange and transfer lands vested in The Uniting Church in Australia Property Trust (Victoria) as are given to the said Trust by *The Uniting Church in Australia Act 1977* (Victoria).

*Purposes to which Proceeds of Disposition are to be Applied*—The proceeds of any sale of real estate shall be applied so far as the proceeds will extend in the following order:

- (a) in the discharge of any encumbrances and liabilities whether personal or otherwise lawfully created or contracted in the due execution of the trusts of these Regulations or such of them or such part thereof respectively as it may be found necessary or expedient so to discharge;
- (b) in the fulfilment of the conditions (if any) imposed by the Synod when consenting to such sale;
- (c) towards any one or more objects hereinafter mentioned:
  - (i) promoting the mission of the Church;
  - (ii) assisting or increasing the funds of any other committee or instrumentality of the Church;
  - (iii) erecting a new church building, church hall, residence or other building to be under the control of the Committee or Parish Council concerned or any other instrumentality of the Church;
  - (iv) carrying out improvements and enlargements to any such existing buildings;
  - (v) purchasing land as a site for a church building, church hall, residence or other building to be under the control of the Committee or Parish Council concerned or any other instrumentality of the Church;
  - (vi) contributing to the funds, objects or charities under the control or direction of the Presbytery, Synod or the Assembly;
  - (vii) such other purposes as the Synod may approve.

As witness the hand of the Governor of the State of Victoria, 23 September 1980—

HENRY WINNEKE  
Governor of the State of Victoria

## VICTORIA

## ACT 391—SECOND SCHEDULE

A statement of trusts having been submitted by the head or authorised representative of the denomination known as the Church of England in the Diocese of Wangaratta in Victoria, pursuant to the provisions of the Act to provide for the abolition of State Aid to Religion, for allowance of His Excellency the Governor (the same was allowed by him on 23 September 1980) and the following is the form in which such statement of trusts has been allowed.

## STATEMENT OF TRUSTS

*Description of Land*—Site for Church of England Place of Public Worship temporarily reserved by Order in Council of 3 August 1868. 7654 square metres, Township of Eldorado, Parish of Tarrawingee, being Crown allotment 6A, section 9. Commencing at the north-western angle of Crown allotment 5, section 9; bounded thence by that allotment and Crown allotment 13 bearing 180 deg. 00 min. 111.04 metres; by Crown allotment 11 bearing 270 deg. 00 min. 100.58 metres; by Horrocks Street bearing 0 deg. 00 min. 41.14 metres and thence by Mackay Street bearing 55 deg. 11 min. 122.51 metres to the point of commencement—(Rs.5902).

*Name of Trustee*—The Church of England Trusts Corporation for the Diocese of Wangaratta of Wangaratta aforesaid.

*Power of Disposition*—Power to sell lease mortgage or exchange all or any part of such land subject to the approval of the Bishop of Wangaratta for the time being or during the absence of the Bishop from the Diocese or the vacancy of the See to the approval of the person for the time being administering the affairs thereof. The land until otherwise disposed of to be held for the purpose for which it was granted or reserved by the Crown.

*Purposes to which Proceeds of Disposition are to be Applied*—To such purposes of the Church of England as may be agreed upon by—

- (1) The Bishop or during his absence from his See or during the vacancy thereof by the person or persons for the time being administering the affairs of the Diocese.
  - (2) The Trustees of the Church of England Trusts Corporation for the Diocese of Wangaratta.
  - (3) The Minister entitled to occupy the aforesaid land.
- As witness the hand of the Governor of the State of Victoria, 23 September 1980—

HENRY WINNEKE  
Governor of the State of Victoria

## VICTORIA

## ACT 391—SECOND SCHEDULE

A statement of trusts having been submitted by the head or authorised representative of the denomination known as the Church of England in the Diocese of Wangaratta in Victoria, pursuant to the provisions of the Act to provide for the abolition of State Aid to Religion, for allowance of His Excellency the Governor (the same was allowed by him on 23 September 1980) and the following is the form in which such statement of trusts has been allowed.

## STATEMENT OF TRUSTS

*Description of Land*—Site for Church of England purposes, temporarily reserved by Order in Council of 30 December 1867, 8094 square metres, Township of Chiltern, Parish of Chiltern, being Crown allotment 5, section 5. Commencing at the southern angle of Crown allotment 6, section 5; bounded thence by Albert Street bearing 223 deg. 40 min. 80.47 metres; by Crown allotment 10 bearing 313 deg. 40 min. 100.58 metres; by Crown allotment 2 bearing 43 deg. 40 min. 80.47 metres; and thence by Crown allotment 6 bearing 133 deg. 40 min. 100.58 metres to the point of commencement—(C.101130).

*Name of Trustee*—The Church of England Trusts Corporation for the Diocese of Wangaratta of Wangaratta aforesaid.

*Power of Disposition*—Power to sell lease mortgage or exchange all or any part of such land subject to the approval of the Bishop of Wangaratta for the time being or during the absence of the Bishop from the Diocese or the vacancy of the See to the approval of the person for the time being administering the affairs thereof. The land until otherwise disposed of to be held for the purpose for which it was granted or reserved by the Crown.

*Purposes to which Proceeds of Disposition are to be Applied*—To such purposes of the Church of England as may be agreed upon by—

- (1) The Bishop or during his absence from his See or during the vacancy thereof by the person or persons for the time being administering the affairs of the Diocese.
  - (2) The Trustees of the Church of England Trusts Corporation for the Diocese of Wangaratta.
  - (3) The Minister entitled to occupy the aforesaid land.
- As witness the hand of the Governor of the State of Victoria, 23 September 1980—

HENRY WINNEKE  
Governor of the State of Victoria

*Town and Country Planning Act 1961*  
CITY OF CAMBERWELL PLANNING SCHEME 1954  
AMENDMENT No. 49, 1979

*Notice of Approval*

In pursuance of the powers conferred by the *Town and Country Planning Act 1961*, the Governor in Council on 23 September 1980, approved a planning scheme entitled the City of Camberwell Planning Scheme 1959, Amendment No. 49, 1979, in respect of part of the municipal district of the City of Camberwell and such planning scheme comes into operation on the date this Notice of Approval is published in the *Government Gazette*.

A copy of the planning scheme as approved may be inspected, free of charge, during office hours at the office of the Town and Country Planning Board, 235 Queen Street, Melbourne, at the office of the Council of the City of Camberwell at Camberwell, and when available, at the Office of Titles, Melbourne, and at the Central Plan Office of the Department of Crown Lands and Survey, Melbourne.

H. R. TROTTER, Acting Secretary  
Town and Country Planning Board

*Town and Country Planning Act 1961*  
GEELONG REGIONAL PLANNING SCHEME

NOTICE THAT AN AMENDMENT TO THE GEELONG REGIONAL INTERIM DEVELOPMENT ORDER HAS BEEN PREPARED AND IS AVAILABLE FOR INSPECTION

*Amendment No. 16*

Notice is hereby given that the Geelong Regional Commission in pursuance of its powers under the *Town and Country Planning Act 1961* has prepared an Amendment to the Geelong Regional Planning Scheme for various Ordinance changes within the Planning Area of the Geelong Region relating to:

Buildings setbacks from existing or new roads.  
Building heights in the municipalities of Barrabool and Queenscliffe.  
New land use, "Conveyance Line".  
"Conveyance Line" as a permitted use in all zones.

A copy of the Amendment has been deposited at this office—Geelong Regional Commission, State Government Offices, corner Little Malop and Fenwick Streets, Geelong, and at:

Bannockburn Shire Council, High Street, Bannockburn;  
Barrabool Shire Council, 441 Moorabool Street, Geelong;  
Bellarine Shire Council, Collins Street, Drysdale;

Corio Shire Council, "Osborne House", Swinburne Street, North Geelong;

Geelong City Council, Gheringhap Street, Geelong;  
Geelong West City Council, 153 Pakington Street, Geelong West;

Newtown City Council, 263 Pakington Street, Newtown;

Queenscliffe Borough Council, 50 Learmonth Street, Queenscliff, and

South Barwon City Council, 2 Colac Road, Belmont; and at the offices of:

The Town and Country Planning Board, 235 Queen Street, Melbourne, and will be open for inspection during office hours by any person, free of charge.

Any persons affected by the Amendment are required to set forth in writing all objections they may have, addressed to the Secretary, Mr G. R. Cowling, Geelong Regional Commission, P.O. Box 770, Geelong, on or before 1 November 1980 and to state whether they wish to be heard in respect of their objections.

G. R. COWLING, Secretary  
Geelong Regional Commission

*Town and Country Planning Act 1961*  
MELBOURNE METROPOLITAN PLANNING SCHEME  
AMENDMENT No. 115, PART 2A

*Notice of Approval*

In pursuance of the powers conferred by the *Town and Country Planning Act 1961*, the Governor in Council on 23 September 1980, approved a planning scheme entitled the Melbourne Metropolitan Planning Scheme, Amendment No. 115, Part 2A, in respect of part of the municipal districts of the Cities of Coburg and Essendon and the Shire of Bulla and such planning scheme comes into operation on the date this Notice of Approval is published in the *Government Gazette*.

A copy of the planning scheme as approved may be inspected, free of charge, during office hours at the office of the Town and Country Planning Board, 235 Queen Street, Melbourne; at the office of the Melbourne and

Metropolitan Board of Works at 625 Little Collins Street, Melbourne, and when available, at the Office of Titles, Melbourne, and at the Central Plan Office of the Department of Crown Lands and Survey, Melbourne.

H. R. TROTTER, Acting Secretary  
Town and Country Planning Board

*Town and Country Planning Act 1961*  
**SHIRE OF BROADFORD PLANNING SCHEME**  
INTERIM DEVELOPMENT ORDER

*Notice of Approval*

In pursuance of the powers conferred by the *Town and Country Planning Act 1961*, the Governor in Council on 23 September 1980, approved an Interim Development Order made by the Broadford Shire Council for the whole of the municipal district of the Shire of Broadford.

The Interim Development Order provides that the use, subdivision or development of any land within the area described or the erection, construction or carrying out of any buildings, roads or other works thereon is prohibited except in accordance with the provisions of the Order.

A copy of the Interim Development Order and a map showing the area affected may be inspected, free of charge, at the office of the Council of the Shire of Broadford at Broadford, and at the office of the Town and Country Planning Board, 235 Queen Street, Melbourne.

H. R. TROTTER, Acting Secretary  
Town and Country Planning Board

*Town and Country Planning Act 1961*  
**SHIRE OF ROSEDALE PLANNING SCHEME 1976**  
AMENDMENT No. 15, 1979

*Notice of Approval*

In pursuance of the powers conferred by the *Town and Country Planning Act 1961*, the Governor in Council on 23 September 1980, approved a planning scheme entitled the Shire of Rosedale Planning Scheme 1976, Amendment No. 15, 1979, in respect of part of the municipal district of the Shire of Rosedale and such planning scheme comes into operation on the date this Notice of Approval is published in the *Government Gazette*.

A copy of the planning scheme as approved may be inspected, free of charge, during office hours at the office of the Town and Country Planning Board, 235 Queen Street, Melbourne; at the office of the Council of the Shire of Rosedale at Rosedale, and when available, at the Office of Titles, Melbourne, and at the Central Plan Office of the Department of Crown Lands and Survey, Melbourne.

H. R. TROTTER, Acting Secretary  
Town and Country Planning Board

*Town and Country Planning Act 1961*  
**SHIRE OF WOORAYL PLANNING SCHEME**  
REVOCATION No. 4

*Notice of Revocation*

In pursuance of the provisions of section 32 of the *Town and Country Planning Act 1961* the Governor in Council on 23 September 1980, made an Order:—

- (i) Revoking the Shire of Woorayl Planning Scheme in so far as applies to approximately 750 square metres of land being lot 1 on lodged plan 129802, in Long Street, Leongatha; and
- (ii) providing that the land so revoked may be used or developed only as if:
  - (a) it were land to which the Shire of Woorayl Planning Scheme applies;
  - (b) it were land within the Industrial A Zone of that Scheme;
  - (c) the provision of Clause 33 (1) (setback in the Industrial Zones) does not apply.

A copy of the Order may be inspected during office hours at the office of the Town and Country Planning Board, 235 Queen Street, Melbourne, and at the office of the Council of the Shire of Woorayl at Leongatha.

H. R. TROTTER, Acting Secretary  
Town and Country Planning Board

*Cemeteries Act 1958*  
**SCALE OF FEES OF THE DAYLESFORD PUBLIC CEMETERY**

In pursuance of the powers conferred upon them by the *Cemeteries Act*, the trustees of the Daylesford Public Cemetery hereby make the following scale of fees, which shall come into operation upon publication in the *Government Gazette*, and from and after such publication every scale of fees heretofore made by the said trustees shall be and is hereby rescinded to the extent to which it conflicts with this scale.

	\$
Exhuming the remains of a body (when authorised)	250.00

J. MURRAY, Trustee  
K. V. RAE, Trustee  
P. OGLETHORPE, Trustee

Approved by the Governor in Council, 23 September 1980—TOM FORRISTAL, Clerk of the Executive Council

*Cemeteries Act 1958*  
**SCALE OF FEES OF THE LAKES ENTRANCE PUBLIC CEMETERY**

In pursuance of the powers conferred upon them by the *Cemeteries Act*, the trustees of the Lakes Entrance Public Cemetery hereby make the following scale of fees, which shall come into operation upon publication in the *Government Gazette*, and from and after such publication every scale of fees heretofore made by the said trustees shall be and is hereby rescinded to the extent to which it conflicts with this scale.

	\$
Land, 2.44 m x 1.22 m	44.00
Permission to erect a headstone or monument— 5 per cent of cost with a minimum of \$10.00.	

R. KENT, Trustee  
R. O. FISH, Trustee  
L. FREEMAN, Trustee

Approved by the Governor in Council, 23 September 1980—TOM FORRISTAL, Clerk of the Executive Council

*Cemeteries Act 1958*  
**SCALE OF FEES OF THE MEMORIAL PARK PUBLIC CEMETERY**

In pursuance of the powers conferred upon them by the *Cemeteries Act*, the trustees of the Memorial Park Public Cemetery hereby make the following scale of fees, which shall come into operation upon publication in the *Government Gazette*, and from and after such publication every scale of fees heretofore made by the said trustees shall be and is hereby rescinded to the extent to which it conflicts with this scale.

	\$
<i>Cremation</i>	
Week day other than below	175.00
Concession rates—Australian ex-service (with overseas service) Pensioners (invalid, aged and widow) evidence to be produced	170.00
Saturday (extra)	100.00

	\$
<i>Lawn Cemetery</i>	
Land, 2.44 m x 1.22 m	
At need fee includes right of burial and first interment	415.00
Interment fee standard	210.00
Pre-need trustees' selection fee includes right of burial and first interment	430.00
Applicant's selection fee as above	445.00
Saturday (extra)	100.00

	\$
<i>Disposal of Cremated Remains</i>	
Strewing of cremated remains in memorial gardens	10.00
Interment of cremated remains in lawn cemetery	40.00
Collection of cremated remains (24 hours notice required)	15.00
Postage of cremated remains within Australia	25.00
Postage of cremated remains (air mail)	40.00

	\$		\$
<i>Miscellaneous Charge</i>		<i>Private Graves</i>	
Exhumation fee (when authorised)	400.00	Land, 2.44 m x 1.22 m own selection	60.00
J. E. PATTERSON, Trustee		Land, 2.44 m x 1.22 m trustee selection	50.00
B. R. MOORE, Trustee		Sinking of grave 2 m deep for adult or person over twelve years	90.00
R. A. WISEMAN, Trustee		Sinking of grave for child three years and under twelve years	40.00
G. J. MACGILL, Manager and Secretary		Sinking grave for child under three years	30.00
		Sinking oversize grave (extra)	15.00
Approved by the Governor in Council, 23 September 1980—TOM FORRISTAL, Clerk of the Executive Council		Reopening grave	90.00
		Removal of ledger and replacing same	10.00
		Interment of ashes in grave	20.00
		Interment fee payable on all graves other than for children under three years	10.00
		Interment on Saturday, Sunday or Public Holidays	
		Double Sinking Fee	
		Interment in grave without exclusive right (public section)—stillborn child	10.00
		Permission to erect a headstone or memorial—5 per cent of cost with minimum of \$10.00.	
		Permission to exhume the remains of a body (when authorised)	150.00
		R. McINTOSH, Trustee	
		W. L. BLAND, Trustee	
		L. J. MORRIS, Trustee	
		Approved by the Governor in Council, 23 September 1980—TOM FORRISTAL, Clerk of the Executive Council	
<i>Cemeteries Act 1958</i>		<i>Education Act 1958</i>	
SCALE OF FEES OF THE WILLIAMSTOWN PUBLIC CEMETERY		NOTICE OF THE MAKING OF ORDERS UNDER SECTION 13 (4) OF THE ACT	
In pursuance of the powers conferred upon them by the Cemeteries Act, the trustees of the Williamstown Public Cemetery hereby make the following scale of fees, which shall come into operation upon publication in the <i>Government Gazette</i> , and from and after such publication every scale of fees heretofore made by the said trustees shall be and is hereby rescinded to the extent to which it conflicts with this scale.		Pursuant to section 13 of the <i>Education Act 1958</i> I hereby give notice that Orders of the Governor in Council were made on 23 September 1980, under sub-section (4) of the said Act amending certain provisions relating to the membership of the State Schools Councils listed below:	
	\$	ST. ALBANS SPECIAL SCHOOL. SPRINGVALE PRIMARY SCHOOL.	
<i>Monumental Section</i>		A. J. HUNT Minister of Education	
Land, 2.44 m x 1.22 m		<i>Education Act 1958</i>	
At need fee includes right of burial and first interment	320.00	NOTICE OF THE MAKING OF ORDERS UNDER SECTION 13 (4) OF THE ACT	
Pre-need trustees' selection fee includes right of burial and first interment	330.00	Pursuant to section 13 of the <i>Education Act 1958</i> I hereby give notice that Orders of the Governor in Council were made on 23 September 1980, under sub-section (4) of the said Act amending certain provisions relating to the membership of the State Schools Councils listed below:	
Applicant's selection fee as above	340.00	488 MERNDA PRIMARY SCHOOL. 1183 WILLIAMSTOWN PRIMARY SCHOOL. 3943 MONT ALBERT PRIMARY SCHOOL. 6207 BOISDALE CONSOLIDATED SCHOOL. 8555 GARDENVALE CENTRAL SCHOOL.	
<i>Lawn Section</i>		A. J. HUNT Minister of Education	
Land, 2.44 m x 1.22 m		<i>Education Act 1958</i>	
At need fee includes right of burial and first interment	370.00	NOTICE OF THE MAKING OF ORDERS UNDER SECTION 13 (4) OF THE ACT	
Pre-need trustees' selection fee includes right of burial and first interment	385.00	Pursuant to section 13 of the <i>Education Act 1958</i> I hereby give notice that Orders of the Governor in Council were made on 23 September 1980, under sub-section (4) of the said Act amending certain provisions relating to the membership of the State Schools Councils listed below:	
Applicant's selection fee as above	395.00	488 MERNDA PRIMARY SCHOOL. 1183 WILLIAMSTOWN PRIMARY SCHOOL. 3943 MONT ALBERT PRIMARY SCHOOL. 6207 BOISDALE CONSOLIDATED SCHOOL. 8555 GARDENVALE CENTRAL SCHOOL.	
Interment fee standard includes monumental and lawn	220.00	A. J. HUNT Minister of Education	
Saturday (extra)	100.00	<i>Education Act 1958</i>	
<i>Miscellaneous Charges</i>		NOTICE OF THE MAKING OF AN ORDER UNDER SECTION 13 (4) OF THE ACT	
Interment of cremated remains	40.00	Pursuant to section 13 of the <i>Education Act 1958</i> I hereby give notice that an Order of the Governor in Council was made on 23 September 1980, under sub-section (4) of the said Act amending certain provisions relating to the Constitution of the Berwick High School Council.	
Exhumation fee (when authorised)	400.00	A. J. HUNT Minister of Education	
<i>Concrete Vaults</i>		<i>State Savings Bank Act 1958, Section 30</i>	
Supply, installation and interment in concrete vault	995.00	THE STATE SAVINGS BANK OF VICTORIA	
J. E. PATTERSON, Trustee		ESTABLISHMENT OF BRANCH	
B. R. MOORE, Trustee		The Commissioners of The State Savings Bank of Victoria hereby give notice of the establishment of Craigieburn Branch of the Bank at Craigieburn Shopping Centre, Corner Craigieburn Road and Hanson Road, Craigieburn, 3064 on 1 October 1980.	
R. A. WISEMAN, Trustee		H. E. TORRENS, General Manager	
G. J. MACGILL, Manager and Secretary			
Approved by the Governor in Council, 23 September 1980—TOM FORRISTAL, Clerk of the Executive Council			
<i>Cemeteries Act 1958</i>			
SCALE OF FEES OF THE YARRAM PUBLIC CEMETERY			
In pursuance of the powers conferred upon them by the Cemeteries Act, the trustees of the Yarram Public Cemetery hereby make the following scale of fees, which shall come into operation upon publication in the <i>Government Gazette</i> , and from and after such publication every scale of fees heretofore made by the said trustees shall be and is hereby rescinded to the extent to which it conflicts with this scale.			
	\$		
<i>Lawn Section (Udenominational)</i>			
Land, 2.44 m x 1.22 m	150.00		
Sinking of grave 2 m deep	100.00		
Plaque supplied by the trustees	100.00		
Interment fee	10.00		
Flower container supplied by the trustees	10.00		
Reopening fee for previously used graves (including additional lettering)	200.00		
Burial of ashes in lawn	30.00		
Interment on Saturday, Sunday or Public Holidays			
Double Sinking Fee			

Co-operation Act 1958

CHANGE OF NAME OF A SOCIETY

Notice is hereby given that Manifold Co-operative Credit Society Limited which is incorporated as a Credit Society under the above-named Act on 12 December 1962, has registered a change of its name and is now incorporated under the name of Manifold Credit Union Co-operative Limited under the said Act.

Dated at Melbourne, 26 February 1980

J. W. BLACKMAN  
Acting Deputy Registrar

G.P.14432, G.P.14433A, G.P.14433B, G.P.14434A, G.P.14434B, G.P.14435C and G.P.14435D attached to the resolution and which was published in the *Government Gazette* on the Thirtieth day of May One thousand nine hundred and seventy-nine on pages 1667 to 1669 be altered by deleting the expression "G.P.14435D" and substituting the expression "G.P.14435E".

COUNTRY ROADS BOARD

RESOLUTIONS OF THE COUNTRY ROADS BOARD

The Country Roads Board, in pursuance of the provisions of the *Country Roads Act 1958*, has passed Resolutions the dates whereof and the terms of which are scheduled hereunder:

SCHEDULE

Main Roads

Resolution dated the Seventeenth day of September One thousand nine hundred and eighty, made pursuant to section 21 of the *Country Roads Act 1958* declaring the widening of Combiobar Road in the Shire of Orbost as shown hatched on plan numbered G.P.15058 hereunder to be part of a main road within the meaning and for the purposes of the said Act.

MAIN ROAD  
COMBIENBAR ROAD  
SHIRE OF ORBOST  
Lengths in metres

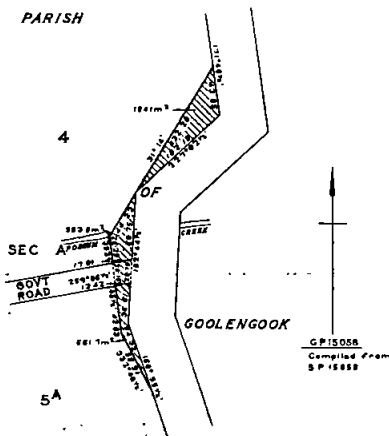

MAIN ROAD  
WARRAGUL - KORUMBURRA ROAD  
SHIRE OF WARRAGUL  
Lengths in metres

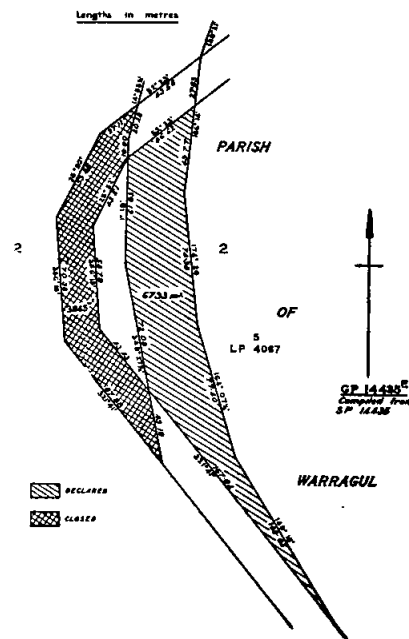

Tourists' Road

Resolution dated the Seventeenth day of September One thousand nine hundred and eighty, resolves that the resolution passed by the Board on the Twenty-first day of May One thousand nine hundred and seventy-nine declaring the deviation from the Warragul-Korumburra Road in the Shire of Warragul as indicated by diagonal hatching, vertical hatching and cross hatching on plans numbered

Resolution dated the Seventeenth day of September One thousand nine hundred and eighty, made pursuant to sections 21, 58 and 88 of the *Country Roads Act 1958*, declaring the deviation from the Marysville-Woods Point Road in the Shire of Healesville as indicated by diagonal hatching on plans numbered G.P.14242A and G.P.14242B hereunder to be part of a tourists' road within the meaning



and for the purposes of the said Act, and also declaring that such deviation shall be in lieu of the existing road or part thereof indicated by cross hatching on the said plan.

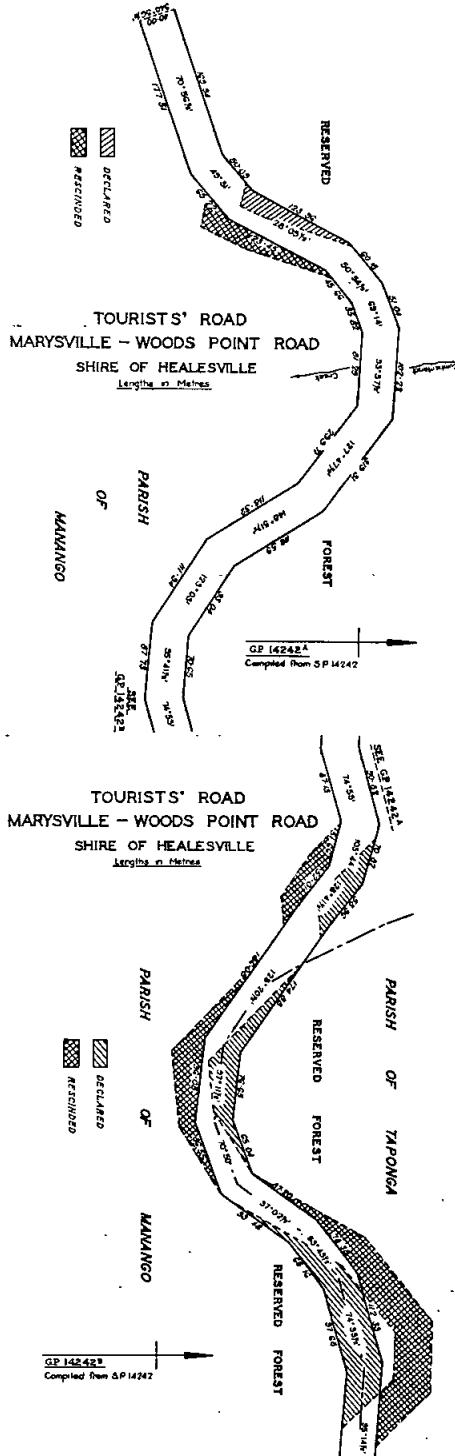

22 September 1980

G. K. COX, Secretary

**APPOINTMENT OF THE QUEEN ELIZABETH GERIATRIC CENTRE AS A TRUSTEE OF THE BENEVOLENT ASYLUM RESERVE, BALLARAT**

His Excellency the Governor of the State of Victoria, in the Commonwealth of Australia, by and with the advice of the Executive Council of the said State, has been pleased to appoint The Queen Elizabeth Geriatric Centre, a body corporate under the provisions of the *Hospitals and Charities Act 1958*, as sole Trustee of the land in the Township of Ballarat, permanently reserved as a site for Benevolent Asylum by Order in Council of 9 September 1878 (see *Government Gazette* dated 13 September 1878), and being the land described in Crown Grants Volume 1091 Folio 218018 and Volume 1176 Folio 235061, in the place of Robert Lewis, Andrew Anderson, William Dimsey, James Oddie and Daniel Brophy, all deceased—(L3-840).

TOM FORRISTAL  
Clerk of the Executive Council

At the Executive Council Chamber  
Melbourne, 23 September 1980

**APPOINTMENTS AND RESIGNATIONS**

**APPOINTMENTS**

His Excellency the Governor of the State of Victoria, by and with the advice of the Executive Council thereof, has, by Orders made on 23 September 1980, been pleased to make the under-mentioned appointments, viz.:

**DEPARTMENT OF COMMUNITY WELFARE SERVICES**

*Honorary Probation Officers*

ELIZABETH ISABEL BELT, 47 Church Street, Benalla,  
MARGARET AIRLIE BLACK, 16 Crofton Street, Benalla,  
JOYCE EMILY ELSTON, 115 Binney Street, Euroa,  
JOHN RODERIC HAWKINS, Avaca Lane, South Wangaratta,  
HEATHER MAREE JUDD, "Wilden Park", Goomalibbee  
R.S.M., via Benalla,  
JENNIFER MARGARET LACEY, 6 Short Street, Benalla,  
JANET MACKENZIE, care of P.O. Merton,  
DESMOND PAUL NICEL, R.M.B. 1740, Euroa,  
FREDA VICTORIA OULD, Mansfield Road, Benalla (Box 106),  
KERRY LEE PEAKE, 27 Smythe Street, Benalla,  
BETTE YVONNE PRANGE, P.O. Euroa, and  
RALPH JACK MACKENZIE, P.O. Box 80, Dimboola,  
to be Honorary Probation Officers, for all Adult and Children's Courts in Victoria, pursuant to the provisions of section 507 (2) of the *Crimes Act 1958*, and section 9 of the *Children's Court Act 1973*.

**DEPARTMENT OF CROWN LANDS AND SURVEY**

*Managers of Moyston Common*

RONALD HENRY KENT,  
ALAN CHARLES KENT, and  
EDWARD KEITH BEGELHOLE,  
to be Managers of the Moyston Common, for the period ending 31 December 1982, pursuant to the provisions of section 182 of the *Land Act 1958*—(Rs.465).

*Bailiffs of Crown Lands*

RICHARD JAMES QUINN,  
to be a Bailiff of Crown lands, without salary, recommended pursuant to the provisions of section 30 of the *Land Act 1958*, in respect of the reserved Crown lands in the Parish of Echuca North known as the "Campaspe Park Raceway", and with authority to enforce all the regulations made with respect to the care, protection and management of the said Reserve.

DENNIS GILFOYLE,  
to be appointed a Bailiff of Crown lands, without additional salary, recommended pursuant to the provisions of section 30 of the *Land Act 1958*, in respect of the Crown lands in the City of Melbourne (at Swanston Street) deemed to be permanently reserved for a State Library, National Museum and Science Museum, and with authority to discharge and exercise all the duties and powers of bailiffs of Crown lands—(Rs.4622).

EDWARD MATHEW ADAMS, and  
GARRY EDWARD ADAMS,  
to be appointed Bailiffs of Crown lands, without salary, recommended pursuant to the provisions of section 30 of the *Land Act 1958*, in respect of the reserved Crown lands in the Township of Warrnambool known as the "Lake Pertrobe and E. Johnson Reserve", and with authority to enforce all the regulations made with respect to the care protection and management of the said Reserve—(Rs.11321).

JOHN EDWARD WAINWRIGHT, and  
JOHANNES MATTHEUS SCHUURMAN,  
to be appointed Bailiffs of Crown lands, without salary recommended pursuant to the provisions of section 30 of the *Land Act 1958*, in respect of the reserved Crown land in the Parish of Sherwood known as the "Tooradin Fore-shore Reserve" with authority to enforce all the regulations made with respect to the care protection and management of the said Reserve—(Rs.3850).

#### HEALTH COMMISSION

##### Trustees of Public Cemeteries

JOHN EVANS,  
to be an additional Trustee of the Mysia Public Cemetery.  
ROY SCHULLER,  
BRIAN HEET,  
MAXWELL HEET,  
IVAN WERNER,  
LESLIE POLACK,  
MERVYN WUNDERSITZ, and  
CLARENCE BOEHM,  
to be additional Trustees of the Lochiel Public Cemetery.  
JAMES WILLIAM BRENNAN,  
to be a Trustee of the Yarram Public Cemetery (vice T. Murphy, resigned), pursuant to section 3 (1) of the *Cemeteries Act 1958*.

##### Members of the Victorian Nursing Council

ELAINE PHILLIPA ORR,  
NORMA ELIZABETH BRYAN,  
SHIRLEY RUTH JENNINGS,  
ROBYN MILLERSHIP,  
ANNE KLEPNER,  
PATRICIA DUFFUS,  
DOROTHY RAE ANSTEE,  
JOYCE BUCKLAND,  
DAVID WILLIAM FRASER,  
PATRICIA VIOLET SLATER,  
NANCY SEWELL,  
ANNE HUTCHISON GRIEVE,  
THELMA JEAN MATSON,  
ERIC RAYMUND SMITH,  
MONICA MARY HAINS,  
EDWARD GORDON BARNARD,  
NANCIE LOIS MILLER,  
BERTRAM PAYNE McCLOSKEY,  
WARREN MURRAY WHITE,  
JAMES BREHENY,  
JOYCE MARGARETTA DAWS,  
JAMES FINLAY PATRICK,  
IVAN LIGHT,  
GORDON EDWARDS,  
JOHN MACCLELLAND,  
GWENNETH McRAE, and  
MERLYN PRITCHARD,  
to be Members of the Victorian Nursing Council pursuant to the provisions of section 4 (2) of the *Nurses Act 1958* for a period of three years commencing on 29 September 1980.

JOYCE PARKER NIXON,  
to be a Member of the Victorian Nursing Council pursuant to the provisions of section 4 (2) (e) (i) of the *Nurses Act 1958* for the period 29 September 1980 to 1 March 1981.

#### LAW DEPARTMENT

##### Commissioners for Taking Declarations, &c.

JOAN ADDAMO, 226 Lorimer Street, Port Melbourne,  
GREGORY KEITH AULT, 117-119 Hotham Street, Traralgon,  
ANTHONY JOHN BOURKE, Gellibrand Street, Colac,  
JACK STEPHEN BROWN, 1331 Ferntree Gully Road,  
Scoresby,

PATRICK CHARLES DORIAN, 500 Bourke Street, Melbourne,  
BERNARD DUFFY, 367 Collins Street, Melbourne, and  
PAUL ANTHONY WRAY, 31B Langhorne Street, Dandenong,  
to be Commissioners for Taking Declarations and Affidavits under the *Evidence Act 1958*.

#### MINISTRY FOR POLICE AND EMERGENCY SERVICES

##### Properly Qualified Analyst

DR ALAN BENTLEY ATCHISON, B.Ag.Sc. (Hons., Adel.),  
Ph.D., Police Forensic Science Laboratory,  
to be a Properly Qualified Analyst for the purposes of section 80D of the *Motor Car Act 1958*.

TOM FORRISTAL

Clerk of the Executive Council

At the Executive Council Chamber  
Melbourne, 23 September 1980

#### Liquor Control Act 1968

##### APPOINTMENT OF LICENSING INSPECTOR

Whereas on 6 February 1980, Sinclair Imrie Miller, the Chief Commissioner of Police for the State of Victoria acting pursuant to the power vested in him by Section 6A of the *Police Regulation Act 1958* delegated to me the undersigned David John Swanson being an Assistant Commissioner of Police for the said State and the person referred to in the said delegation all powers and functions vested in him by the *Liquor Control Act 1968*, from 6 February 1980, now therefore I do hereby appoint the following Officer of Police as a Licensing Inspector for the Division of the Police District as shown:

Division Number	Police District	Rank and Name
2	Melbourne	Inspector Leslie Charles Walsh (from 5.10.80 to 8.11.80)
26.9.1980		D. J. SWANSON Assistant Commissioner (Services)

#### REVOCATION OF APPOINTMENTS

His Excellency the Governor of the State of Victoria, by and with the advice of the Executive Council thereof, has, by Orders made on 23 September 1980, revoked the appointments of the persons named hereunder to the offices mentioned, viz.:—

#### DEPARTMENT OF CROWN LANDS AND SURVEY

##### Bailiff of Crown Lands

JOHN DOUGLAS CRAWFORD,  
as a Bailiff of Crown Lands (made by the Governor in Council on 25 July 1978, see *Government Gazette* dated 2 August 1978)—(Rs.10209).

#### LAW DEPARTMENT

##### Justice of the Peace

KEITH SYDNEY DEVENPORT,  
as a Justice of the Peace.

TOM FORRISTAL

Clerk of the Executive Council

At the Executive Council Chamber  
Melbourne, 23 September 1980

#### RESIGNATIONS

His Excellency the Governor of the State of Victoria, by and with the advice of the Executive Council thereof, has, by Orders made on 23 September 1980, accepted the resignations of the persons named hereunder of the offices mentioned, viz.:—

#### DEPARTMENT OF COMMUNITY WELFARE SERVICES

##### Probation and Parole Officer

KATHLEEN JULIE CARROLL,  
as a Probation and Parole Officer, pursuant to the provisions of section 9 (2) of the *Children's Court*

Act 1973, section 507 (1) of the *Crimes Act 1958* and sections 165 (1) and 189 (2) of the *Social Welfare Act 1970* (as amended).

LAW DEPARTMENT

Justices of the Peace

ERIC JOHN MILLARD, and  
LILLIAN MARGARET O'HARA,  
as Justices of the Peace for the State of Victoria.

Commissioners for Taking Declarations, &c.

IAN ALEX ATKYNS,  
EDMOND JOHN PATRICK CONDON,  
WILLIAM STANLEY HILDEBRAND, and  
WILLIAM ARTHUR WOODALL,  
as Commissioners for taking Declarations and Affidavits under the *Evidence Act 1958*.

TOM FORRISTAL  
Clerk of the Executive Council

At the Executive Council Chamber  
Melbourne, 23 September 1980

**ORDERS IN COUNCIL**

LOCAL GOVERNMENT ACT 1958

At the Executive Council Chamber, Melbourne, the  
twenty-third day of September, 1980

PRESENT:

His Excellency the Governor of Victoria  
Mr Houghton | Mr Granter  
Mr Lacy

ROAD RETAINED—SHIRE OF BULN BULN

Whereas it is provided by paragraph (baa) of subsection (2) of section 528 of the *Local Government Act 1958*, that where pursuant to an Order made by the Governor in Council under the provisions of this section or any corresponding previous enactment is in force before the commencement of the *Local Government (Amendment) Act 1962* any road or part of a road was discontinued and the land and soil thereof vested in the municipality, then if the said land has not been sold the Governor in Council may by a further Order published in the *Government Gazette* direct that the land shall be retained by the municipality for municipal purposes.

And whereas by an Order made under the said subsection and published in the *Government Gazette* of 13 August 1980 the part of a road indicated by hatching on the plan hereunder was discontinued.

Now therefore, His Excellency the Governor of the State of Victoria by and with the advice of the Executive Council thereof, hereby directs that the land in the said part of a road shall be retained by the Council of the Shire of Buln Buln for municipal purposes.

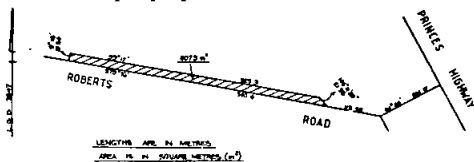

And the Honourable Digby Glen Crozier, Her Majesty's Minister for Local Government for the State of Victoria, shall give the necessary directions herein accordingly.

TOM FORRISTAL  
Clerk of the Executive Council

LOCAL GOVERNMENT ACT 1958

At the Executive Council Chamber, Melbourne, the  
twenty-third day of September, 1980

PRESENT:

His Excellency the Governor of Victoria  
Mr Houghton | Mr Granter  
Mr Lacy

ROAD DISCONTINUED—SHIRE OF BAIRNSDALE

Whereas it is provided by section 528 (2) of the *Local Government Act 1958* that where a road (whether or not a public highway but not being a road set out on land of the Crown) or any part thereof is not required for public use the Governor in Council on the request of the council of the municipality in which such road is situated made not less than one month after publishing in a newspaper generally circulating in the district and posting to the registered proprietor (if any) of the land and the owners and occupiers (if any) of lands abutting or immediately adjacent to the road notice of intention to make such a request may by Order published in the *Government Gazette* direct that such road or part shall be discontinued and thereupon such road or part shall be discontinued accordingly.

And whereas the Council of the Shire of Bairnsdale has requested that the Governor in Council direct that a road off King Street Paynesville be discontinued and not less than one month previously has published in a newspaper generally circulating in the district and posted to the registered proprietor of the land in the road and to the owners and occupiers of lands abutting or immediately adjacent to the road notice of intention to make such a request.

Now therefore, His Excellency the Governor of the State of Victoria, by and with the advice of the Executive Council thereof, hereby directs that the said road which is shown by hatching on the plan hereunder shall be discontinued and that the land may be sold by the Council of the Shire of Bairnsdale by agreement.

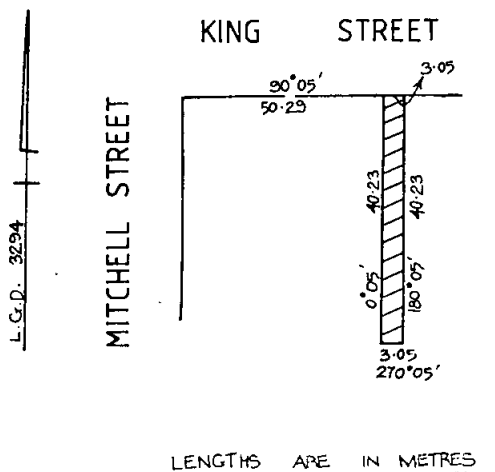

And the Honourable Digby Glen Crozier, Her Majesty's Minister for Local Government for the State of Victoria, shall give the necessary directions herein accordingly.

TOM FORRISTAL  
Clerk of the Executive Council

LOCAL GOVERNMENT ACT 1958

At the Executive Council Chamber, Melbourne, the twenty-third day of September, 1980

PRESENT:

His Excellency the Governor of Victoria  
 Mr Houghton | Mr Granter  
 Mr Lacy

ROAD DISCONTINUED—TOWN OF PORTLAND

Whereas it is provided in section 528 (2) of the *Local Government Act 1958*, that where a road (whether or not a public highway but not being a road set out on land of the Crown) or any part thereof is not required for public use, the Governor in Council on the request of the council of the municipality in which such road is situated made not less than one month after publishing in a newspaper generally circulating in the district and posting to the registered proprietor (if any) of the land and the owners and occupiers (if any) of lands abutting or immediately adjacent to the road notice of intention to make such a request may by Order published in the *Government Gazette* direct that such road or part shall be discontinued and thereupon such road or part shall be discontinued accordingly.

And whereas the Council of the Town of Portland has requested that the Governor in Council direct that part of a road off Tyers Street, Portland, be discontinued and not less than one month previously has published in a newspaper generally circulating in the district and posted to the registered proprietors of the land in the road and to the owners and occupiers of lands abutting or immediately adjacent to the road notice of intention to make such a request.

Now therefore, His Excellency the Governor of the State of Victoria, by and with the advice of the Executive Council thereof, hereby directs:—

- (a) that the said part of a road which is shown by hatching and cross hatching on the plan hereunder, shall be discontinued;
- (b) that notwithstanding such discontinuance the Portland Sewerage Authority shall continue to have and possess the same right title power authority or interest in or in relation to the whole of the land shown by cross hatching in the said road as it had or possessed prior to such discontinuance with respect to or in connection with any drains or pipes laid or erected in on or over such land for the purposes of sewerage; and
- (c) that, subject to any such right title power authority or interest the land in the said road may be sold by the Council of the Town of Portland by agreement.

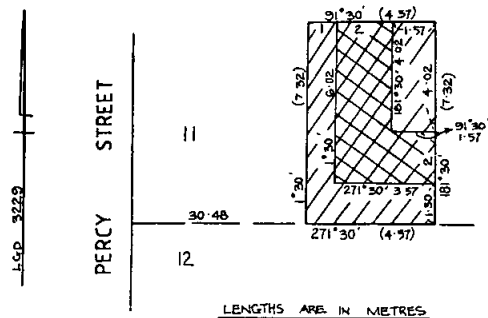

And the Honourable Digby Glen Crozier, Her Majesty's Minister for Local Government for the State of Victoria, shall give the necessary directions herein accordingly.

TOM FORRISTAL  
 Clerk of the Executive Council

LOCAL GOVERNMENT ACT 1958

At the Executive Council Chamber, Melbourne, the twenty-third day of September, 1980

PRESENT:

His Excellency the Governor of Victoria  
 Mr Houghton | Mr Granter  
 Mr Lacy

APPROVAL OF RATING AGREEMENT BETWEEN THE SHIRE OF BROADFORD AND ANDERSON HONEY PRODUCTS PTY. LTD.

Whereas—

- (a) Anderson Honey Products Pty. Ltd., is liable to be rated in respect of the land described as Lot 7 on Plan of Subdivision No. 119217 being part of Crown Allotment 58E Parish of Broadford which land is not within the Metropolitan area within the meaning of the *Town and Country Planning Act 1961*;
- (b) The Council of the Shire of Broadford is of the opinion that the establishment and maintenance of the industry within the municipality is making and will continue to make a substantial contribution to the industrial development of the municipality and encourage the decentralization of industry in Victoria; and
- (c) The President, Councillors and Ratepayers of the Council of the Shire of Broadford and Anderson Honey Products Pty. Ltd., have entered into an agreement in respect of the above described land as to the amount of rates that will be payable thereon by the said firm under the *Local Government Act 1958*, and copies of such agreement have been submitted to the Minister for Local Government.

Now therefore, His Excellency the Governor of the State of Victoria, by and with the advice of the Executive Council thereof and in pursuance of the provisions of the said section 811BA of the *Local Government Act 1958*, hereby approve the said agreement.

And the Honourable Digby Glen Crozier, Her Majesty's Minister for Local Government for the State of Victoria, shall give the necessary directions herein accordingly.

TOM FORRISTAL  
 Clerk of the Executive Council

LOCAL GOVERNMENT ACT 1958

At the Executive Council Chamber, Melbourne, the twenty-third day of September, 1980

PRESENT:

His Excellency the Governor of Victoria  
 Mr Houghton | Mr Granter  
 Mr Lacy

APPROVAL OF RATING AGREEMENT BETWEEN THE SHIRE OF WARANGA AND D. A., J. & W. A. MAUDE

- (a) Whereas—D. A., J. and W. A. MAUDE are liable to be rated in respect of certain land being Crown Allotment 2 of section 5, Township of Rushworth, Parish of Moora which land is not within the Metropolitan area within the meaning of the *Town and Country Planning Act 1961*;
- (b) The Council of the Shire of Waranga is of the opinion that the land is to be used for the accommodation or entertainment of tourists; and
- (c) The President, Councillors and Ratepayers of the Council of the Shire of Waranga and D. A., J., and W. A. Maude have entered into an agreement in respect of the above described land as to the amount of rates that will

be payable thereon by the said D. A., J., and W. A. Maude under the *Local Government Act 1958*, and copies of such agreement have been submitted to the Minister for Local Government.

Now therefore, His Excellency the Governor of the State of Victoria, by and with the advice of the Executive Council thereof and in pursuance of the provisions of the said section 811BA of the *Local Government Act 1958*, hereby approve the said agreement.

And the Honourable Digby Glen Crozier, Her Majesty's Minister for Local Government for the State of Victoria, shall give the necessary directions herein accordingly.

TOM FORRISTAL  
Clerk of the Executive Council

#### ORBOST WATERWORKS TRUST

At the Executive Council Chamber, Melbourne, the twenty-third day of September, 1980

PRESENT:

His Excellency the Governor of Victoria  
Mr Houghton | Mr Granter  
Mr Lacy

#### EXTENT OF WATERWORKS AND NEWMERELLA URBAN DISTRICTS INCREASED

Under the powers conferred by the Water Act and all other powers enabling him in that behalf, His Excellency the Governor of the State of Victoria, by and with the advice of the Executive Council of the said State, doth hereby declare, order and direct that the extent of the Waterworks and Newmerella Urban Districts of the Orbost Waterworks Trust be increased by adding to the same the lands shown by red and yellow borders respectively on the plan approved by the Governor in Council and deposited in the office of the State Rivers and Water Supply Commission, Melbourne (Corr. No. 72/3143/175) and as on and from the date hereof, the extent of such Districts shall be and be deemed to be increased accordingly.

And the Honourable Frederick James Granter, Her Majesty's Minister of Water Supply for the State of Victoria, shall give the necessary directions herein accordingly.

TOM FORRISTAL  
Clerk of the Executive Council

#### SHIRE OF CRANBOURNE SEWERAGE AUTHORITY

At the Executive Council Chamber, Melbourne, the twenty-third day of September, 1980

PRESENT:

His Excellency the Governor of Victoria  
Mr Houghton | Mr Granter  
Mr Lacy

#### APPROVAL TO ABANDON PORTION OF THE PROPOSED SITE FOR AN OUTFALL MAIN APPROVAL OF SITE OF OUTFALL MAIN, AMENDED SITE OF OUTFALL MAIN AND ACQUISITION OF EASEMENTS AND LICENCES

Under the powers conferred by the Sewerage Districts Act and all other powers enabling him in that behalf, His Excellency the Governor of the State of Victoria, by and with the advice of the Executive Council of the said State, doth hereby approve of:

- (a) the abandoning of portion of the site for an outfall main shown by green colour on the plan accompanying this Order and approved by the

Governor in Council by and with this Order and deposited in the office of the State Rivers and Water Supply Commission, Melbourne (Corr. No. 78/3201/54) such site being shown on the plan approved by Order in Council, dated 8 January 1980;

- (b) the amended site for the outfall main as shown by purple colour on the said plan;
- (c) the site required for an outfall main as shown on the said plan; and
- (d) the acquisition by the Shire of Cranbourne Sewerage Authority of the easements and licences required over the works as shown by red and yellow colours respectively on the said plan.

And the Honourable Frederick James Granter, Her Majesty's Minister of Water Supply for the State of Victoria, shall give the necessary directions herein accordingly.

TOM FORRISTAL  
Clerk of the Executive Council

#### GAS ACT 1969, SECTION 29

At the Executive Council Chamber, Melbourne, the twenty-third day of September, 1980

PRESENT:

His Excellency the Governor of Victoria  
Mr Houghton | Mr Granter  
Mr Lacy

#### FEES FOR TESTING OF METERS

In pursuance of the provisions of the Gas Act 1969, No. 7886, and all other powers enabling him in that behalf, His Excellency the Governor of the State of Victoria, by and with the advice of the Executive Council thereof, doth hereby determine that the following fees are payable for the testing of meters as on and from 1 October 1980.

	\$
For every meter of a capacity not exceeding 4.3 cubic metres per hour	3.50
For every meter of a capacity exceeding 4.3 cubic metres per hour and not exceeding 5.7 cubic metres per hour	5.00
For every meter of a capacity exceeding 5.7 cubic metres per hour and not exceeding 17 cubic metres per hour	7.00
For every meter of a capacity exceeding 17 cubic metres per hour and not exceeding 34 cubic metres per hour	14.00
For every meter of a capacity exceeding 34 cubic metres per hour and not exceeding 85 cubic metres per hour	28.00
For every meter of a capacity exceeding 85 cubic metres per hour	35.00

And the Honourable James Charles Murray Balfour, Her Majesty's Minister for Minerals and Energy for the State of Victoria, shall give the necessary directions herein accordingly.

TOM FORRISTAL  
Clerk of the Executive Council

COUNTRY ROADS BOARD  
ACT No. 6229

At the Executive Council Chamber, Melbourne, the  
twenty-third day of September, 1980

PRESENT:

His Excellency the Governor of Victoria  
Mr Houghton | Mr Granter  
Mr Lacy

ORDER APPROVING OF LAND BEING ACQUIRED AND  
ROADS, DEVIATIONS OR WIDENINGS BEING MADE  
TOGETHER WITH ALL ANCILLARY WORKS REQUIRED  
TO BE EXECUTED IN CONJUNCTION THEREWITH

His Excellency the Governor of the State of Victoria, by  
and with the advice of the Executive Council thereof,  
being satisfied that there are funds legally available for  
acquiring the land, doth hereby approve the acquiring of  
the land described in the schedule hereunder and the  
making a new roads and deviations from and widenings of  
existing roads, together with all ancillary works required to  
be executed in conjunction therewith, referred to in the  
said schedule.

SCHEDULE  
State Highways

The land shown hatched on plan numbered G.P.15333  
hereunder required for the widening of the Princes Highway  
in the Shire of Colac and making of the widening thereon.

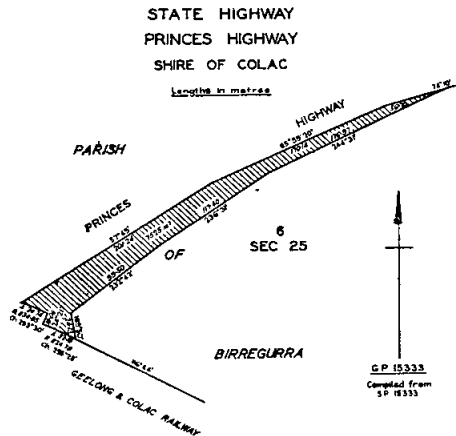

The land shown hatched on plan numbered G.P.15267c  
hereunder required for the widening of the Princes Highway  
in the City of Moe and making of the widening thereon.

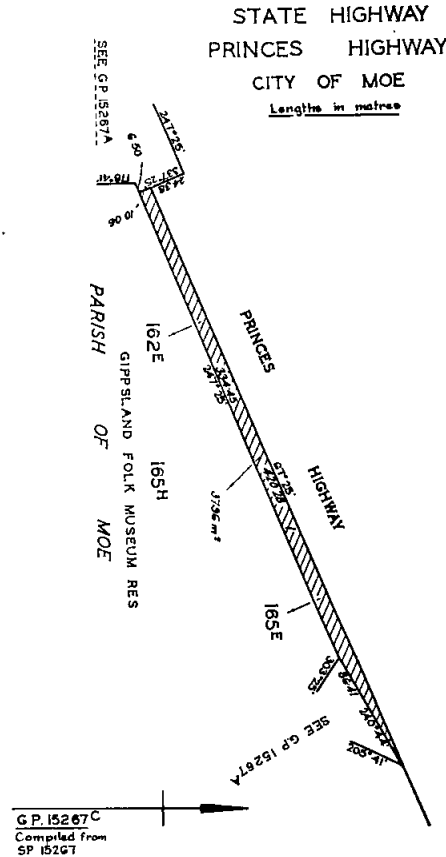

**Main Roads**  
The land shown hatched on plan numbered G.P.14568  
hereunder required for the deviation from Beach Road in  
the City of St. Kilda and making of the deviation thereon.

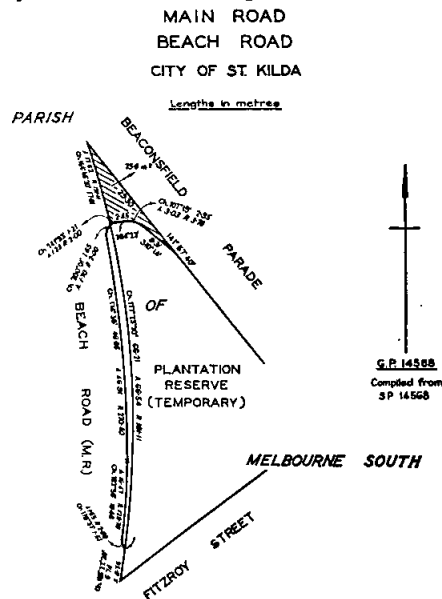

The land shown hatched on plan numbered G.P.15304 hereunder required for the widening of Gelantipy Road in the Shire of Tambo and making of the widening thereon.

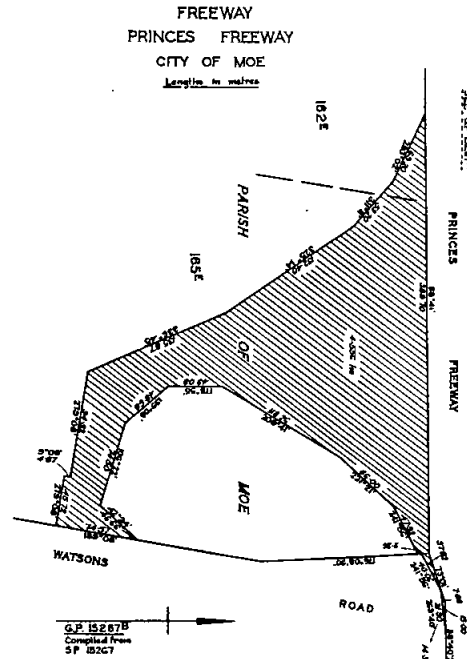
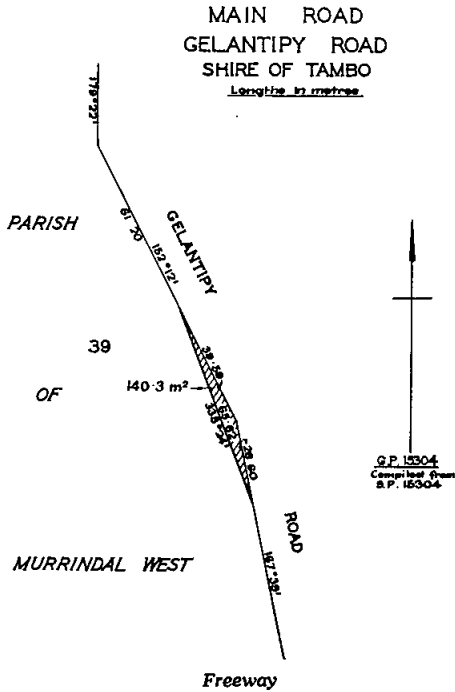

The land shown hatched on plans numbered G.P.15267A and G.P.15267B hereunder required for the widening of the Princes Freeway in the City of Moe and making of the widening thereon.

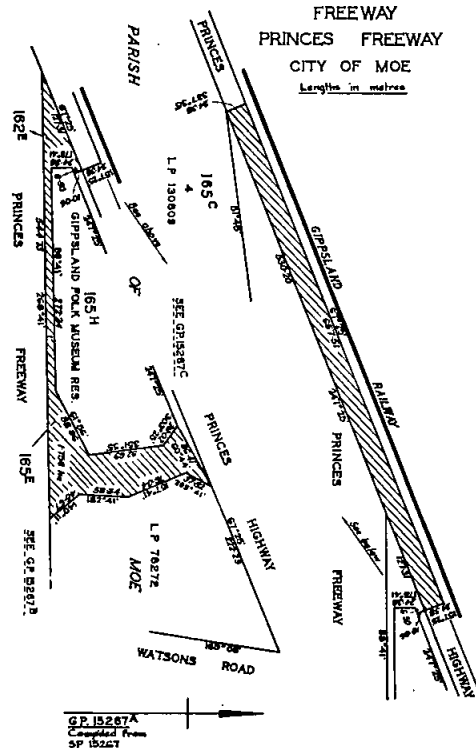

And the Honourable Robert Roy Cameron Maclellan, Her Majesty's Minister of Transport for the State of Victoria, shall give the necessary directions herein accordingly.

TOM FORRISTAL  
Clerk of the Executive Council

SUPERANNUATION ACT 1958

At the Executive Council Chamber, Melbourne, the twenty-third day of September, 1980

PRESENT:

His Excellency the Governor of Victoria  
Mr Houghton | Mr Granter  
Mr Lacy

Pursuant to the powers conferred by the provisions of paragraph (ja) of subsection (1) of section 3 of the Superannuation Act 1958, His Excellency the Governor of the State of Victoria, by and with the advice of the Executive Council thereof doth by this Order declare that the provisions of the Superannuation Act shall apply to the officer named in the schedule set out hereunder.

SCHEDULE

URBAHNS, JOHN GEORGE WILLIAM; Railway Construction and Property Board.

And the Honourable Lindsay Hamilton Simpson Thompson, Her Majesty's Treasurer for the State of Victoria, shall give the necessary directions herein accordingly.

TOM FORRISTAL  
Clerk of the Executive Council

CROWN LAND (RESERVES) ACT 1978

At the Executive Council Chamber, Melbourne, the twenty-third day of September, 1980

PRESENT:

His Excellency the Governor of Victoria  
 Mr Houghton | Mr Granter  
 Mr Lacy |

CROWN LANDS TEMPORARILY RESERVED

His Excellency the Governor of the State of Victoria, in the Commonwealth of Australia, by and with the advice of the Executive Council of the said State, pursuant to the provisions of sections 4 and 7 of the Crown Land (Reserves) Act 1978, and being of the opinion that the Crown lands concerned are required for the purposes respectively mentioned, doth hereby temporarily reserve and also except from occupation for mining purposes under any miner's right, the Crown lands hereinafter described, viz.:

**MARLO**—For Sewerage purposes, 4.718 hectares, being Crown allotment 5, section 7, Township of Marlo, as shown on Certified Plan No. 104528 lodged in the Central Plan Office—(M.538<sup>(e)</sup>) (Rs.10591).

**MYRRHEE**—For Conservation of Area of Natural Interest, 79 hectares, more or less, being Crown allotment 83c, Parish of Myrrhee, as indicated by hatching on plan hereunder—(M.297<sup>(4)</sup>) (Rs.11153).

**TOOLAMBA WEST**—For Public Recreation, 1556 square metres, being Crown allotment 35A, Parish of Tolamba West, as indicated by hatching on plan hereunder—(T.201<sup>(10)</sup>) (Rs.11149).

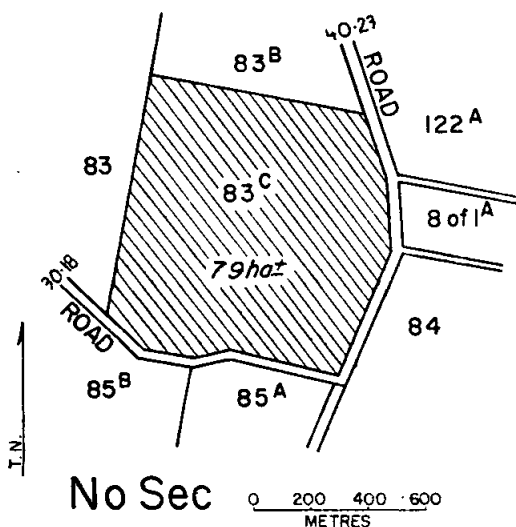
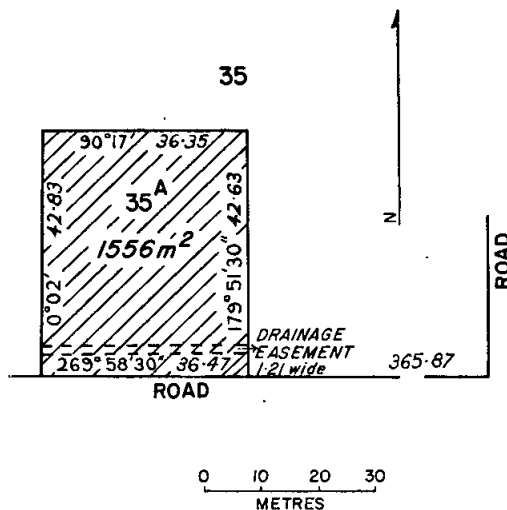

**YANDOIT**—For Conservation of Area of Natural Interest, 6711 square metres, being Crown allotment 19b, section 7A, Parish of Yandoit, as indicated by hatching on plan hereunder—(Y.6<sup>(7)</sup>) (Rs.11214).

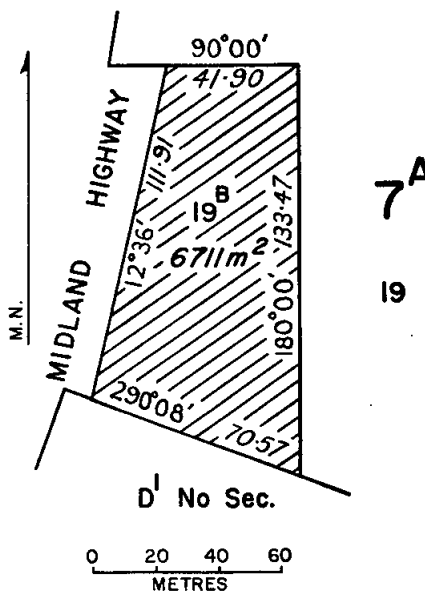

And the Honourable William Vasey Houghton, Her Majesty's Minister of Lands for the State of Victoria, shall give the necessary directions herein accordingly.

TOM FORRISTAL  
 Clerk of the Executive Council



**CROWN LAND (RESERVES) ACT 1978**

At the Executive Council Chamber, Melbourne, the twenty-third day of September, 1980

PRESENT:

His Excellency the Governor of Victoria  
 Mr Houghton | Mr Granter  
 Mr Lacy

**CROWN LANDS TEMPORARILY RESERVED**

His Excellency the Governor of the State of Victoria, in the Commonwealth of Australia, by and with the advice of the Executive Council of the said State, pursuant to the provisions of sections 4 and 7 of the Crown Land (Reserves) Act 1978, and being of the opinion that the Crown lands concerned are required for the public purposes respectively mentioned, doth hereby temporarily reserve and also except from occupation for mining purposes under any miner's right, the Crown lands hereinafter described, viz.:

**WEERING**—For protection of the bed and banks of a lake, 12 hectares, more or less, being Crown allotment 105A, Parish of Weering, as indicated by hatching on plan hereunder—(W.122(4) (Rs.11232).

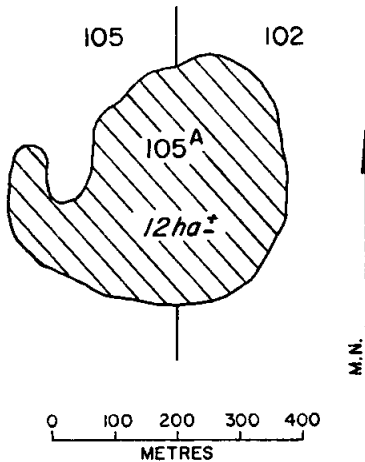

**WILL-WILL-ROOK**—For a Court House, 2215 square metres, being Crown allotment, 10d, Parish of Will-will-rook, as indicated by hatching on plan hereunder—(W.151(2) (Rs.10407).

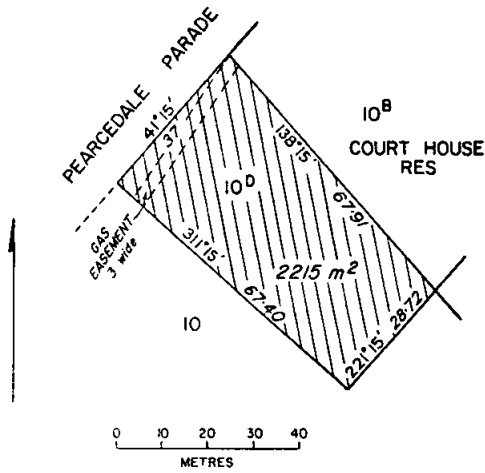

And the Honourable William Vasey Houghton, Her Majesty's Minister of Lands for the State of Victoria, shall give the necessary directions herein accordingly.

TOM FORRISTAL  
 Clerk of the Executive Council

**CROWN LAND (RESERVES) ACT 1978**

At the Executive Council Chamber, Melbourne, the twenty-third day of September, 1980

PRESENT:

His Excellency the Governor of Victoria  
 Mr Houghton | Mr Granter  
 Mr Lacy

**REVOCATION OF WITHHOLDING FROM SALE LEASING AND LICENSING OF LAND BY ORDER IN COUNCIL**

His Excellency the Governor of the State of Victoria, by and with the advice of the Executive Council of the said State, pursuant to the provisions of section 10 of the Crown Land (Reserves) Act 1978, doth hereby revoke the withholding from sale, leasing and licensing by Order in Council of 4 August 1879 of 80.61 hectares of land in the Parish of Bungal, revoked as to part by various Orders, so far as the balance thereof containing 2.7 hectares, more or less, is concerned—(B.548(4) (Rs.11438).

And the Honourable William Vasey Houghton, Her Majesty's Minister of Lands for the State of Victoria, shall give the necessary directions herein accordingly.

TOM FORRISTAL  
 Clerk of the Executive Council

**LAND ACT 1958**

At the Executive Council Chamber, Melbourne, the twenty-third day of September, 1980

PRESENT:

His Excellency the Governor of Victoria  
 Mr Houghton | Mr Granter  
 Mr Lacy

**UNUSED ROADS CLOSED**

His Excellency the Governor of the State of Victoria, in the Commonwealth of Australia, by and with the advice of the Executive Council of the said State, pursuant to the

provisions of section 349 of the Land Act 1958, and with the concurrence in writing of the council of the municipality concerned and that of any adjoining land owners, doth hereby close the unused roads hereinafter described, viz.:

Municipal district of the City of Castlemaine, Township of Castlemaine, being the roads indicated by hatching on plan hereunder—(C.99(8)) (C.100542).

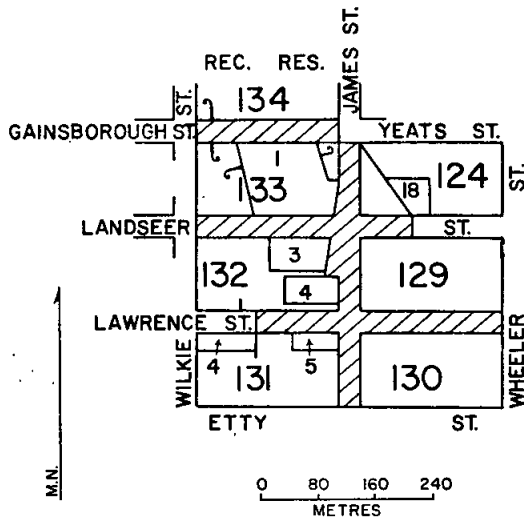

Municipal district of the Shire of Otway, Parish of Yaugher, being the road indicated by hatching on plan hereunder—(Y.115(8)) (L.1-318).

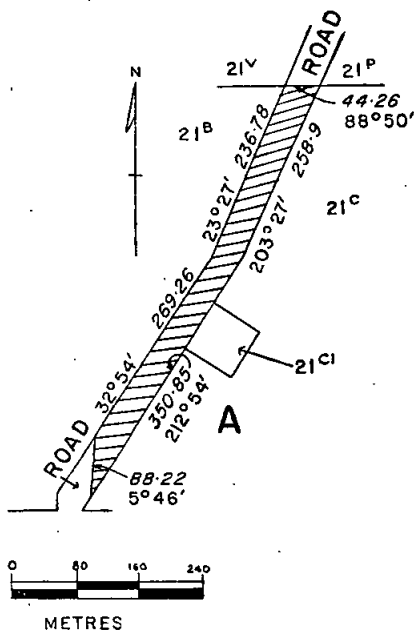

And the Honourable William Vasey Houghton, Her Majesty's Minister of Lands for the State of Victoria, shall give the necessary directions herein accordingly.

TOM FORRISTAL  
Clerk of the Executive Council

ROYAL COMMISSION INTO CERTAIN HOUSING COMMISSION LAND PURCHASES AND OTHER MATTERS

At the Executive Council Chamber, Melbourne, the thirtieth day of September, 1980

PRESENT:

His Excellency the Governor of Victoria

Mr Crozier  
Mr Maclellan

Mr Balfour

Whereas:

1. By Order made on 20 June 1979, and published in the *Government Gazette* on 20 June 1979, The Honourable Sir Sydney Frost, Q.C., LL.M., and Alfred James Ellwood Esquire, LL.M., were appointed a Royal Commission to inquire into and report upon certain matters relating to land purchased by the Housing Commission and to the valuation of land purchased by the Government or its instrumentalities and were directed, with as little delay as possible and by 31 December 1979, at the latest, to report under their hand their opinion resulting from the inquiry.

2. By Order made on 11 December 1979 the latest date upon which the said Sir Sydney Frost and Alfred James Ellwood shall report as aforesaid was extended from 31 December 1979 to 31 May 1980.

3. By Order made on 22 January 1980, and published in the *Government Gazette* on 23 January 1980, the matters upon which the said Sir Sydney Frost and Alfred James Ellwood were to report were extended.

4. By Order made on 20 May 1980, the latest date upon which the said Sir Sydney Frost and Alfred James Ellwood shall report as aforesaid was extended from 31 May 1980 to 31 December 1980.

5. It is expedient that the said Sir Sydney Frost and Alfred James Ellwood shall inquire into and report upon certain other matters.

Now therefore, His Excellency the Governor of the State of Victoria, in the Commonwealth of Australia, by and with the advice of the Executive Council of the said State, by this Order directs that the matters into which the said Sir Sydney Frost and Alfred James Ellwood have been directed to inquire into and report upon should be extended to include the following matters namely:

5. The undermentioned matters arising out of the contract of sale dated 18 July 1972, entered into between the Housing Commission and North Terrace Club Investments Pty. Limited with respect to certain land in an area bounded by Haines Street, Abbotsford Street, O'Shannassy Street and Dryburgh Street and being the balance of the land remaining untransferred in Certificate of Title Volume 8885 Folio 519 as at 1 July 1972 namely:

- (a) whether the consideration for such sale and the terms and conditions thereof were fair and reasonable and appropriate in the circumstances;
- (b) the circumstances and propriety of the Housing Commission entering into agreements of 18 April 1974, and 9 April 1976, with the Australia and New Zealand Banking Group Limited ("the Bank") with respect to sums of \$1 800 000 and \$4 200 000, respectively, to be made available by the Bank to Inge Bros. Developments (Aust.) Pty. Limited which that company was to use to develop the land the subject of the aforesaid contract of sale on behalf of North Terrace Pty. Investments Pty. Limited;
- (c) whether the sale of the land and the intended development of the land as referred to in the special conditions which form part of the aforesaid contract of sale was appropriate in the circumstances or whether the Housing Commission should itself have proceeded with the development of the land;
- (d) whether the special conditions in the contract of sale relating to the intended development of the land were appropriate in the circumstances;
- (e) whether the development of the land has been carried out in accordance with the special conditions and, if not, the reason therefor; and

- (f) whether there was any dishonesty, impropriety, malfeasance or negligence on the part of any person in relation to the sale of such land or in arriving at the consideration for the sale of such land or in the determination of the terms and conditions upon which the said land was sold or in the arrangements made by the Housing Commission with regard to the loan by the Australia and New Zealand Banking Group Limited to Inge Bros. Developments (Aust.) Pty. Limited.

And the Honourable Haddon Storey, Her Majesty's Attorney-General for the State of Victoria, shall give the necessary directions herein accordingly.

L. G. HOUSTON  
Acting Clerk of the Executive Council

#### TRARALGON WATERWORKS TRUST

At the Executive Council Chamber, Melbourne, the thirtieth day of September, 1980

PRESENT:

His Excellency the Governor of Victoria	
Mr Crozier	Mr Balfour
Mr Maclellan	

#### CONSENT TO BORROWING \$100 000

Under the powers conferred by the Water Act and all other powers enabling him in that behalf, His Excellency the Governor of the State of Victoria, by and with the advice of the Executive Council of the said State, hereby consents to the Traralgon Waterworks Trust borrowing the sum of One hundred thousand dollars (\$100 000) to meet the cost of water supply works.

And the Honourable Frederick James Granter, Her Majesty's Minister of Water Supply for the State of Victoria, shall give the necessary directions herein accordingly.

L. G. HOUSTON  
Acting Clerk of the Executive Council

#### CRIMINAL INJURIES COMPENSATION ACT 1972

At the Executive Council Chamber, Melbourne, the thirtieth day of September, 1980

PRESENT:

His Excellency the Governor of Victoria	
Mr Crozier	Mr Balfour
Mr Maclellan	

#### NOTICE FIXING AMOUNT OF \$7500 FOR THE PURPOSES OF SECTION 16

Whereas:

1. Sub-section (1) of section 16 of the *Criminal Injuries Compensation Act 1972* provides that where the Crimes Compensation Tribunal decides to make an order for the payment of compensation under the said Act, the Tribunal may award such amount as it thinks fit by way of general damages or special damages or both but not exceeding in the aggregate—

- in the case of a lump sum—\$3000 or such other amount as the Governor in Council fixes from time to time by notice published in the *Government Gazette*;
- in the case of weekly payments or in the case of a lump sum and weekly payments—an aggregate amount of \$3000 or such other amount as the Governor in Council fixes from time to time by notice published in the *Government Gazette*.

2. The maximum amount of compensation payable under the said section was increased to \$5000 by order of the Governor in Council on 11 January 1977, such amount to

apply in respect of compensation payable for compensable death or injury occasioned by criminal act or by omissions occurring on or after 1 December 1976.

3. It is considered that the amount of \$5000 is inadequate to properly compensate persons who are injured and who have recourse to the Crimes Compensation Tribunal.

4. It is considered that the maximum amount of compensation payable under the said section be increased to \$7500.

Now therefore, His Excellency the Governor of the State of Victoria, by and with the advice of the Executive Council thereof, doth by this notice fix the amount of \$7500 for the purposes of sub-section (1) of section 16 of the *Criminal Injuries Compensation Act 1972*, such amount to apply in respect of compensation payable for compensable death or injury occasioned by criminal act or by omissions occurring on or after 1 October 1980.

And the Honourable Haddon Storey, Her Majesty's Attorney-General for the State of Victoria, shall give the necessary directions herein accordingly.

L. G. HOUSTON  
Acting Clerk of the Executive Council

#### FRUIT AND VEGETABLES ACT 1958

At the Executive Council Chamber, Melbourne, the thirtieth day of September, 1980

PRESENT:

His Excellency the Governor of Victoria	
Mr Crozier	Mr Balfour
Mr Maclellan	

Under the powers conferred by section 48 of the *Fruit and Vegetables Act 1958*, His Excellency the Governor of the State of Victoria, by and with the advice of the Executive Council thereof doth hereby authorize the persons named hereunder who are Inspectors under the said Act, to take proceedings in respect of offences against Part II. of the said Act or the Regulations thereunder.

RIDLEY WILLIAM BELL  
KEITH WALTER BLACKMORE

And the Honourable Ian Winton Smith, Her Majesty's Minister of Agriculture for the State of Victoria, shall give the necessary directions herein accordingly.

L. G. HOUSTON  
Acting Clerk of the Executive Council

#### Zoological Parks and Gardens Act 1967 ROYAL MELBOURNE ZOOLOGICAL GARDENS REGULATIONS 1980

At the Executive Council Chamber, Melbourne, the thirtieth day of September, 1980

PRESENT:

His Excellency the Governor of Victoria	
Mr Crozier	Mr Balfour
Mr Maclellan	

In pursuance of the powers conferred by the *Zoological Parks and Gardens Act 1967*, and all other powers him thereunto enabling, His Excellency the Governor of the State of Victoria, by and with the advice of the Executive Council thereof, doth hereby make the following Regulations:—

1. These Regulations may be cited as the Royal Melbourne Zoological Gardens Regulations 1980.

2. In these Regulations the Zoological Parks and Gardens Regulations 1980, are called the Principal Regulations.

3. Notwithstanding anything contained in the Principal Regulations, on Sunday, 19 October 1980, all children over four and under fifteen years shall be admitted to the Royal Melbourne Zoological Gardens without charge.

4. Notwithstanding anything contained in the Principal Regulations admission to the Royal Melbourne Zoological Gardens shall be without charge on the days and conditions specified hereunder for the classes of persons specified hereunder:

- (a) On each Saturday and Sunday during October 1980 (except Sunday, 19 October 1980) Children over four and under fifteen years on surrender of complimentary tickets issued by Coca Cola Bottlers, provided that each child is accompanied by an adult who has paid the normal admission fee to the Gardens, on a one to one basis.
- (b) On each day during October 1980 (except Sunday 19 October 1980) Children over four and under fifteen years on surrender of complimentary tickets issued by McDonalds System of Australia, provided that each child is accompanied by an adult who has paid the normal admission fee to the Gardens, on a one to one basis.

5. For Regulation 32 of the Principal Regulations there shall be substituted the following Regulation:

"32. Any person who is guilty of a breach of any of the foregoing Regulations shall be liable to a penalty not exceeding \$50.00."

And the Honourable William Vasey Houghton, Her Majesty's Minister for Conservation for the State of Victoria, shall give the necessary directions herein accordingly.

L. G. HOUSTON  
Acting Clerk of the Executive Council

NOTE—Copies of these Regulations may be obtained at the offices of the Ministry for Conservation, 240 Victoria Parade, East Melbourne.

**LANDS DEPARTMENT  
NOTICES**

**APPROACHING LAND SALES**

Sale of Crown Land, will be held at the under-mentioned places and dates, viz:—

	No. of Gazette
Bendigo—Tuesday, 14 October 1980	74
Fitzroy—Saturday, 1 November 1980	84
Kaniva—Monday, 13 October 1980	68
Melbourne—Wednesday, 15 October 1980	75
Yarram—Thursday, 23 October 1980	80

**SALE OF FREEHOLD LAND BY AUCTION**

Cooramook—Friday, 17 October 1980	70
-----------------------------------	----

**SALE OF CROWN LAND BY AUCTION**

The land will be offered for sale subject to the provisions of the Land Act and Regulations thereunder.

The upset price is the sum at which bidding will start, and no bid below that sum can be accepted. The highest bidder at or above that sum shall be the purchaser, subject to signature of contract and any necessary payment.

**TERMS:**

A deposit of at least 12½% of the purchase price must be paid at the sale, either in cash or by cheque.

The residue is payable in 20 half-yearly instalments, or may be paid off at any earlier time.

Interest at the rate of 9% per annum is payable with all payments of residue, and is computed for each instalment from the date of sale to the date of such payment. Additional interest is charged if any instalment is not paid on or before the due date.

If paid off within 30 days of sale, no interest is payable.

**FEES, ETC.:**

Survey fee is payable at the sale.

Payable with balance of purchase money—  
Crown Grant—\$30.00.

Transfer of interest prior to completion of payment may be allowed on payment of \$22 fee and subject to stamp duty.

If unable to attend personally, a prospective purchaser may arrange for another person to bid as his agent.

Attention is drawn to section 95, Land Act 1958; which provides that the purchaser shall be deemed to be the owner for the purpose of other Acts; also to an amendment to the Local Government Act providing for Government roads, in certain circumstances, to be declared "private streets", thus making the purchaser liable to contribute to the cost of street construction.

W. V. HOUGHTON  
Minister of Lands

Department of Crown Lands and Survey  
Melbourne, 1 October 1980

FITZROY—Sale (No. 12321) of Crown land, at auction, will be held on the site at 108 ALEXANDRA PARADE, FITZROY, on SATURDAY, 1 NOVEMBER 1980 at 11.00 A.M. To be conducted by E. KENNEDY, Land Officer, Melbourne.

**Lot 1**

**PARISH OF JIKA JIKA**

Being the property known as 108 Alexandra Parade, Fitzroy

Upset price \$26 000.00 the lot. Survey fee \$300.00  
Area 128 square metres, allotment 84c.

Improvements comprise a single fronted brick terrace cottage containing two bedrooms, kitchen, bathroom and adjoining w.c.

The subject cottage has been recently painted and noise reduction measures effected. Zoned Residential "B" in Melbourne Metropolitan Planning Scheme.

**Special Conditions:**

1. Party wall easement 0.11 metres wide.
2. Until the purchase money has been paid in full the following Special Conditions shall apply—
  - (i) The purchaser shall at his own expense maintain the property in good order and repair and keep all improvements thereon insured against fire, storm and tempest in the name of the Secretary for Lands.
  - (ii) A cover note for such insurance shall be lodged in the Department of Crown Lands and Survey, by the purchaser, within one week of the date of sale, and the policy shall be lodged immediately on issue.
  - (iii) The purchaser shall not remove or make any alterations to the improvements on the site without prior consent of the Secretary for Lands.

Inspection by arrangement with Land Officer, Melbourne. Telephone 651 2919—(L.11-2292).

**PROPOSED REVOCATIONS OF TEMPORARY RESERVATIONS OF LANDS BY ORDERS IN COUNCIL**

In pursuance of the provisions of section 10 of the Crown Land (Reserves) Act 1978, notice is hereby given that it is the intention of the Governor in Council to revoke the temporary reservations of lands by Orders in Council hereunder referred to, viz.:

**BRUTHEN**—The temporary reservation by Order in Council of 24 September 1912 of 4047 square metres of land in the Township of Bruthen as a site for Public purposes—(B.790<sup>(\*)</sup>) (Rs.1670).

**NEWMERELLA**—The temporary reservation by Order in Council of 7 March 1961 of 59.89 hectares, more or less, of land in the Parish of Newmerella (in section C) as a site for Public Recreation—(Rs.8016).

**CARRARAGARMUNGEE**—The temporary reservation by Order in Council of 14 June 1898 of 9358 square metres of land in the Parish of Carraragarmungee (in section 8A) as a site for Water Supply purposes—(L.8-1406).

**CASTLEMAINE**—The temporary reservation by Order in Council of 23 August 1966 of 2.832 hectares, more or less, of land in the Township of Castlemaine, as a site for Public Recreation, so far only as the portion thereof containing 1140 square metres, more or less, as indicated by hatching on plan hereunder—(C.99<sup>(\*)</sup>) (Rs.8634).

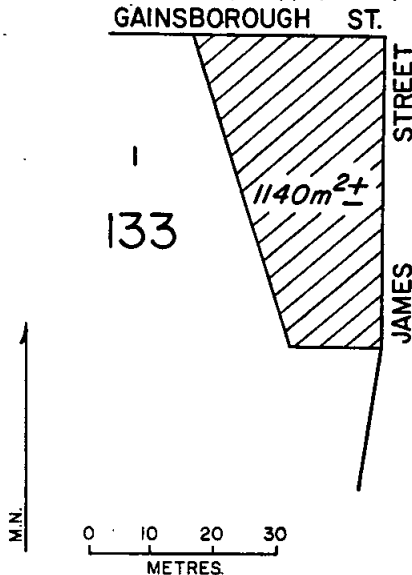

**NORTH HAMILTON**—The temporary reservation by Order in Council of 27 October 1970 of 1.128 hectares of land in the Parish of North Hamilton as a site for Public Purposes (Trigonometrical Survey Station), so far only as the portion thereof containing 7323 square metres, as indicated by hatching on plan hereunder, is concerned—(H.46<sup>(\*)</sup>) (Rs.9293).

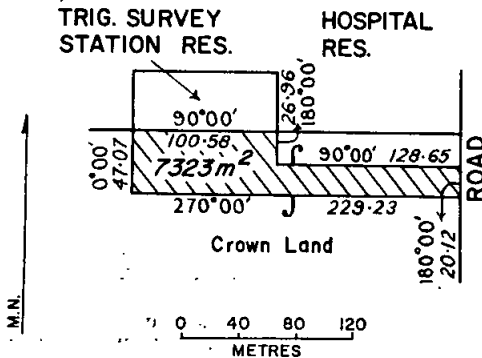

**PURRUMBETE NORTH**—The temporary reservation as a site for affording access to Water and the withholding from sale, leasing and licensing by Order in Council of 28 November 1881 of 26.22 hectares of land in the Parish of Purrumbete North, revoked as to part by Order of 12 February 1980, so far as the balance thereof containing 23.17 hectares, is concerned—(P.100<sup>(\*)</sup>) (Rs.9787).

**SANDHURST (EAGLEHAWK)**—The temporary reservation as a site for Storm Water Channel and the withholding from sale, leasing and licensing by Order in Council of 11 February 1878 of 1.796 hectares of land at Eaglehawk, Parish of Sandhurst (called municipal District of Eaglehawk in Order), revoked as to part by various Orders, so far only as the portion thereof containing 9400 square metres, more or less, as indicated by hatching on plan hereunder, is concerned—(Parish 3473-3) (Rs.6900).

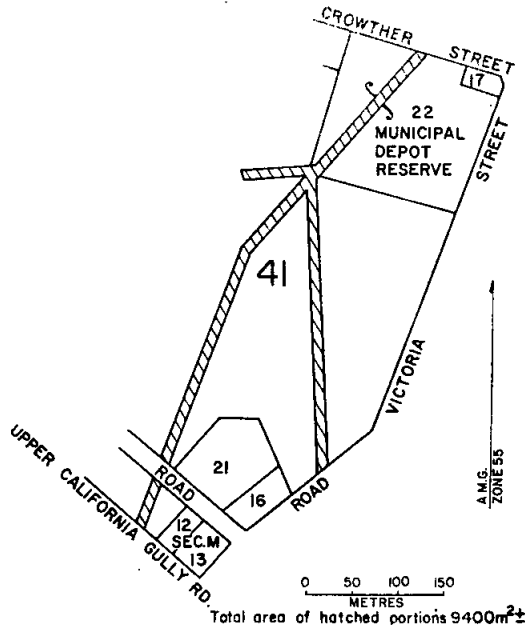

W. V. HOUGHTON  
Minister of Lands

**COMMITTEE OF MANAGEMENT OF SIDNEY MYER MUSIC BOWL, CITY OF MELBOURNE**

In pursuance of section 14 of the Crown Land (Reserves) Act 1978, I hereby appoint the Victorian Arts Centre Trust, in lieu of all previous appointments which are hereby revoked, as the Committee of Management of the land in the City of Melbourne, Parish of Melbourne South, permanently reserved for a Public Park, being that portion in the said land containing approximately 1 hectare (2 acres 1 rood 35 perches) shown on plan C.P.58814 lodged at the Central Plan Office of the Department of Crown Lands and Survey—(Corres. No. C.97387).

W. V. HOUGHTON  
Minister of Lands

Department of Crown Lands and Survey  
Melbourne, 16 September 1980

## TENDERS

### PUBLIC WORKS DEPARTMENT

Tenders are invited for the purposes indicated hereunder and will be received at 2 Treasury Place, Melbourne, 3002, until **TWO** p.m. on dates shown.

Tenders must be addressed to the Minister of Public Works with the envelope endorsed "Tender for

". Hand-delivered tenders must be placed in the Department's tender box in the foyer, Ground Floor, 2 Treasury Place, Melbourne.

Tenders documents are available from the Contracts Office, Room 29, 2 Treasury Place, Melbourne and where indicated, at offices of Inspectors of Works.

★Tenders for works identified with star (★) will only be considered from Contractors qualified for repairs and painting works. Any Tenderers wishing to qualify may obtain the application form from the Contracts Office.

**Tuesday, 14 October 1980**

#### Building, Electrical and Mechanical Works

**ALBERT PARK**—(Readvertisement, amended specification)—New canteen, High School.

**BALLARAT**—Alterations to premises, Early Childhood Development Centre. (W.O., Ballarat.)

★**EAGLEHAWK**—External and internal renovations, Station and Residence. (W.O., Bendigo.)

**KNOX**—Connection to sewer, Technical School and Bayswater South Primary School.

**MELBOURNE**—Supply and installation of standby alternator for communications centre, Police Station—East Wing.

#### Miscellaneous

**BLACK ROCK**—Maintenance cleaning for period 1 December 1980 to 30 November 1983, Police Station and District Head Quarters.

**DROMANA**—Maintenance cleaning for period 1 November 1980 to 31 October 1983, Court House. (W.O., Mornington.)

**ECHUCA**—(Readvertisement)—Maintenance cleaning for period 3 November 1980 to 31 October 1983, Agriculture, F. & W.L., Police. (W.O., Echuca.)

**FRANKSTON**—Maintenance cleaning for period 1 December 1980 to 30 November 1983, Regional Office.

**FRANKSTON**—Maintenance cleaning for period 1 November 1980 to 31 October 1983, Regional Office.

**HAMPTON**—Maintenance cleaning for period 1 December 1980 to 30 November 1983, C.I.B.

**KYNETON**—Maintenance cleaning, period 1 November 1980 to 31 October 1983, P.W.D., Lands, Agriculture, C.W.S. (W.O., Kyneton.)

**LILYDALE**—Maintenance cleaning for period 1 November 1980 to 31 October 1983, Soil Conservation Authority.

**MANSFIELD**—Maintenance cleaning for period 1 December 1980 to 30 November 1983, Police Station.

**MENTONE**—Maintenance cleaning for period 1 December 1980 to 30 November 1983, Police Station.

**MORNINGTON**—Maintenance cleaning for period 1 December 1980 to 30 November 1983, Police Station, C.I.B., M.R.B. (W.O., Mornington.)

**PORT MELBOURNE**—Purchase of two (2) only petrol driven vibrating plates, Depot.

**Tuesday, 21 October 1980**

#### Building, Electrical and Mechanical Works

**ARARAT**—(Readvertisement, amended specification)—Extensions to existing building, Police Station. (W.O., Ararat, Ballarat and Horsham.)

**CARDROSS**—Electrical services—Staff accommodation and improvements, provision of canteen and toilets and relocatable classrooms, Primary School.

**CARDROSS**—Mechanical services—Staff accommodation and improvements, provision of canteen and toilets and relocatable classrooms, Primary School.

★**FOOTSCRAY**—Internal and external repairs, renovations, alterations and painting, Girls High School.

★**FOOTSCRAY**—Internal and external repairs and painting and minor alterations, Primary School No. 253.

**HEIDELBERG WEST**—Installation of new fire service, Olympic Village Primary School No. 4713.

**NORTHCOTE**—Installation of fire service and water supply, Primary School No. 3139.

**SOUTH YARRA**—Renovations to public toilets, Royal Botanical Gardens.

**WARRANTYTE SOUTH**—Sewage treatment plant, Primary School No. 3476.

**NUNAWADING**—PABX telephone system, "Winlton" Youth Training Centre.

#### Site Works

**MULLUM**—Access road and associated drainage, Primary School.

#### Miscellaneous

**PORT MELBOURNE**—Purchase of one (1) only amenities, Radar caravan 18 ft. x 8 ft., Depot.

**Tuesday, 28 October 1980**

#### Building, Electrical and Mechanical Works

**CARDROSS**—Staff accommodation and improvements, provision of canteen and toilets and relocatable classrooms, Primary School. (W.O., Mildura.)

TOM AUSTIN  
Minister of Public Works

Public Works Department  
Melbourne, 30 September 1980

## PRIVATE ADVERTISEMENTS

### CITY OF BOX HILL

Notice is hereby given that the City of Box Hill has appointed Senior Sergeant James Kane No. 13363 replacing Senior Sergeant Frederick Patrick Galliver No. 10933, as Prosecuting Officer, to take legal proceedings on behalf of the Council for and in connexion with breaches and non-observance of the Local Government Act or any other Act which the Council from time to time is empowered to enforce and any by-laws, rules and regulations made under such Acts.

I. G. PORT  
Town Clerk

Municipal Offices, Whitehorse Road, Box Hill 9994

### CITY OF BRUNSWICK

#### NOTICE OF INTENTION TO ACQUIRE LAND COMPULSORILY

Whereas the Mayor Councillors and Citizens of the City of Brunswick (hereinafter called "the Council") deem it expedient to exercise its powers of taking land compulsorily for the work or undertaking mentioned hereunder, Notice is hereby given as follows:

1. The Council intends to take compulsorily All that piece of land known as No. 64 John Street, East Brunswick and being part of Crown Portion 96 Parish of Jika Jika County of Bourke and being the whole of the land more particularly described in Certificate of Title Volume 7821 Folio 126 in the Register Book and as appears in the sketch plan set out hereunder for the purpose of widening the entrance from John Street, East Brunswick to Balfe Park which is owned by the Council and to form part of such Park.

2. A copy of general description of the said work or undertaking and of the plan of such land and a statement of the parties having interests therein are deposited at the Brunswick Town Hall, Sydney Road, Brunswick and are there available for inspection by all interested parties during office hours free of charge for the period of 40 clear days from the date of publication of this Notice in the *Victorian Government Gazette*.

3. The Council hereby requires all persons affected by the said proposal to set forth in writing addressed to the Town Clerk, City of Brunswick, Town Hall, Sydney Road, Brunswick within 40 clear days from the date of publication aforesaid all objections which they may have to the taking of the said land.

4. At the ordinary meeting of the Council next after the expiration of the said 40 clear days the Council will consider any such objection and any person so objecting as aforesaid may appear before the Council in support of such objection.

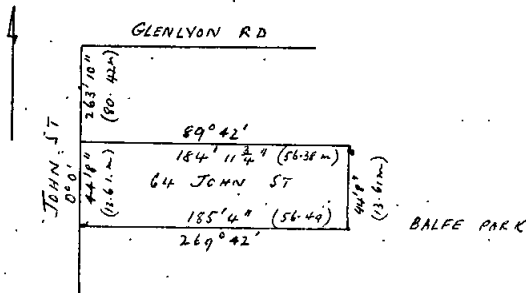

Dated 26 September 1980

By Order of the Council

K. D. WILSON, Town Clerk

Slater & Gordon, 60 Market Street, Melbourne, solicitors for the council 10064

CITY OF KNOX

NOTIFICATION OF CHANGES IN STREET NAMES

Notice is hereby given that in pursuance of powers conferred by the *Local Government Act 1958*, the Council of the City of Knox at a meeting held on 9 September 1980, resolved to make the following street name change.

Old Name—Bradman Street, Boronia.

New Name—Bradman Court, Boronia (change of name effective from 1 January 1981).

9983 T. J. NEVILLE, Town Clerk

CITY OF PRAHRAN

LOAN No. 101

Notice of Intention to Borrow the Sum of \$200 000 for Permanent Works and Undertakings

Notice is hereby given that the Council of the City of Prahran proposes to borrow the sum of \$200 000 secured by a charge over the general rates of the Municipality, such sum to be raised by the grant of a mortgage in accordance with the provisions of the *Local Government Act 1958*.

1. The maximum rate of interest that may be paid is 12.6 per cent per annum.

2. The purpose for which the loan is to be applied is the renovation and extension of the Prahran Market.

3. The loan shall have a currency of 10 years and interest thereon shall be payable half yearly on 15 May and 15 November in each year, the first payment to be made on 15 May 1981; the principal sum to be repayable in full at the expiration of the 10 year term. All payments are to be made to the Insurance Commissioner, State Insurance Office, 480 Collins Street, Melbourne, 3000.

4. The loan is to be liquidated by a Sinking Fund which shall be created in accordance with the provisions of the *Local Government Act* by the half-yearly investment of \$7443.14 at not less than 6 per cent per annum.

The plans and specifications and the estimate of the cost of the proposed works and a statement showing the proposed expenditure of the monies to be borrowed are open for inspection at the Office of the Council of the City of Prahran, Chapel Street, Prahran, 3181.

10000

D. G. JESSON, Town Clerk

CITY OF PRESTON

By-Law No. 99

Management and Control of Libraries

In accordance with Section 197 of the *Local Government Act 1958*, notice is hereby given that the Council of the City of Preston has made a By-Law under the provisions of the said Act for the proper management and control of libraries belonging to, or under the control and management of the Preston City Council.

A copy of the By-Law is available for inspection by any interested person at the Town Hall, High Street, Preston, during office hours.

Dated 1 October 1980

9991

N. E. L. ROBINSON, Town Clerk

Town and Country Planning Act 1961 (Twelfth Schedule)

CITY OF SHEPPARTON PLANNING SCHEME, 1953.

NOTICE THAT A PLANNING SCHEME HAS BEEN PREPARED AND IS AVAILABLE FOR INSPECTION

Amendment No. 54, 1980

Notice is hereby given that the Council of the City of Shepparton, in pursuance of its powers under the *Town and Country Planning Act 1961*, has prepared a planning scheme for the purpose of including a new zone in the City of Shepparton Planning Scheme, to be known as the Commercial "E" Zone (Highway Frontages) to apply to the following areas:

The Goulburn Valley Highway, both sides, between Hawkins Street and Ford/Wanganui Roads;

The Midland Highway (Benalla Road), both sides, between St. Georges Road and the City boundary (excluding the site of the showgrounds and the S.E.C. Zone Sub-Station).

A copy of the Scheme has been deposited at the office of the Council, Civic Centre, Shepparton, and at the office of the Town and Country Planning Board, 235 Queen Street, Melbourne, and will be open for inspection during office hours by any person free of charge.

Any persons affected by the Planning Scheme are required to set forth in writing all objections they may have, addressed to the Town Clerk, City of Shepparton, P.O. Box 989, Shepparton, on or before 1 November 1980, and to state whether they wish to be heard in respect of their objections.

9988

I. L. GILBERT, Acting Town Clerk

CITY OF SWAN HILL

LOAN No. 84

Notice of Intention to Borrow the Sum of \$110 000 for Permanent Works and Undertakings

Notice is hereby given that the Council of the City of Swan Hill proposes to borrow the principal sum of One hundred and ten thousand dollars (\$110 000) secured by a charge over the general rates of the Municipality, such sum to be raised by a grant of a mortgage in accordance with the provisions of the *Local Government Act 1958*.

1. The maximum rate of interest that may be paid is 12.6 per centum per annum.

2. The purpose for which the loan is to be applied is for:

- (a) Development of off street parking in Chapman and Beveridge Streets (part) 40 000
- (b) Development of Ken Harrison Sporting Complex (part) 30 000
- (c) Development of new municipal swimming pool (part) 40 000

3. The period of the loan shall be ten (10) years.

4. The money borrowed shall be repayable by providing out of the Municipal Fund half yearly instalments of approximately \$9825.18 payable on 10 June, and 10 December, during the currency of the loan with the first instalment being payable on 10 June 1981.

5. Such moneys shall be repayable to the Commercial Savings Bank of Australia Limited, Campbell Street, Swan Hill, 3585.

The plans and specifications and the estimates of the cost of the proposed works and a statement showing the proposed expenditure of the moneys borrowed are open for inspection at the office of the Council of the City of Swan Hill, Town Hall, Swan Hill.

Dated 26 September 1980

10042

G. J. MENNIE, Town Clerk

#### UNITED SHIRE OF BEECHWORTH

Notice is hereby given that Council has appointed Mr Leslie Garland as Proper Officer of the United Shire of Beechworth under the Country Fire Authority Act, of 5 September 1980, vice Mr Donald William Pope, resigned.

10043

G. T. GRAY, Shire Secretary

#### SHIRE OF BELLARINE

##### NOTICE OF INTENTION TO ACQUIRE LAND AND EASEMENTS COMPULSORILY

To all whom it may concern—

Whereas the Council of the Shire of Bellarine deems it expedient to exercise its powers of taking land (including easements) compulsorily for the works and undertakings mentioned hereunder.

Notice is hereby given as follows—

1. The Council intends to acquire all that piece of land being part of Crown Allotment 7 Section 13 Parish of Moolap comprising Lot 184 and part of Lots 165, 168 to 183 (both inclusive) and 185 to 198 (both inclusive) on Plan of Subdivision Number 13237 commencing at the southern end of the western boundary of Lot 198 and bounded on the West by a Drainage Reserve bearing North 521.16 metres; on the north-west by a line bearing 49 deg. 40 min. 3.94 metres; on the North by Portarlington Road bearing 99 deg. 19 min. 7.11 metres; on the southeast by a line bearing 229 deg. 39½ min. 3.88 metres; on the East by a line bearing 180 deg. 10 min. 294.56 metres; on the North by part of the northern boundary of Lot 184 bearing 90 deg. 35 min. 42.11 metres; again on the East by Albert Street bearing 180 degrees 15.24 metres; on the South by part of the southern boundary of Lot 184 bearing 270 deg. 35 min. 42.15 metres; again on the East by a line bearing 180 deg. 10 min. 211.56 metres; on the northeast by a line bearing 135 deg. 22 min. 2.55 metres; again on the South by High Street bearing 270 deg. 35 min. 4.29 metres and on the south-west by a line bearing 315 deg. 17 min. 4.33 metres back to the commencing point subject (as to portion of the part of Lot 165 required) to the existing drainage easement thereover and together with easements for drainage purposes over three strips of land 2.50 metres wide along and within—

- (a) the southern boundary of Lot 224 on the said Plan of Subdivision;
- (b) the northern boundary of Lot 213 on the said Plan of Subdivision; and
- (c) the eastern 41.67 metres of the southern boundary of Lot 173 on the said Plan of Subdivision;

all of which land and easement sites are registered in the name of Pamela Ann Godfrey and are required for purposes of widening an existing Drainage Reserve, for access to such widened Reserve and generally for drainage purposes.

2. A copy of a plan of such land and easements and a Schedule of the parties having interests therein are deposited at the Municipal Offices at Drysdale and are there available for inspection by all interested parties during office hours free of charge for the period of 40 clear days from the date of publication of this Notice in the *Government Gazette*.

3. The Council hereby requires all persons affected by the said proposal to set forth in writing addressed to the Shire Secretary, Shire of Bellarine, Drysdale 3222 within 40 clear days from the date of publication aforesaid all objections which they may have to the taking of the said land and easements.

4. At the ordinary meeting of the Council next after the expiration of the said 40 clear days the Council will consider any such objection and any person so objecting as aforesaid may appear before the Council in support of such objection.

Dated 7 August 1980

By Order of the Council

G. L. PEARCE, Shire Secretary

Harwood & Pincott, Geelong, solicitors for the council  
9985

#### SHIRE OF CRANBOURNE

LOAN No. 97

##### Notice of Intention to Borrow

Notice is hereby given that the Council of the Shire of Cranbourne intends to borrow the principal sum of \$200 000.00, secured by a charge over the General Rates of this Municipality; such sum to be raised by the grant of a mortgage in accordance with the provisions of the *Local Government Act 1958* (as amended).

1. The maximum rate of interest that may be paid is 12.6 per cent p.a., payable half-yearly, the first of such payments is to be made on 14 May 1981.
2. The purposes for which the loan is to be applied are as follows:

	\$
Sladen Street, Cranbourne—service road, northern side, across frontage of St. Agatha's Church (part cost)	10 000.00
Heavy Duty Grader	83 000.00
South Gippsland Highway—construction and sealing of service road, between Clarendon Street and Duff Street	65 000.00
Brunt Street, Cranbourne—construction and sealing, between South Gippsland Highway and Codrington Street (part cost)	42 000.00
	200 000.00

3. The period of the loan shall be 10 years.
4. The loan is to be liquidated by the creation of a sinking fund pursuant to the provisions of Section 428A of the *Local Government Act 1958*.
5. The principal shall be repayable to the Insurance Commissioner, State Insurance Office, 480 Collins Street, Melbourne, on 14 November 1990.

The plans and specifications and the estimate of the cost of the proposed work and statement showing the proposed expenditure of the monies to be borrowed, are open for inspection at the office of the Council of the Shire of Cranbourne, Sladen Street, Cranbourne, dated 1 October 1980.

10047

T. VICKERMAN, Shire Secretary

#### SHIRE OF DEAKIN

##### NOTICE OF APPLICATION TO THE MINISTER FOR LOCAL GOVERNMENT FOR AN OVERDRAFT APPROVAL UNDER SECTION 439B OF THE LOCAL GOVERNMENT ACT

The Council has made application for approval of the following proposition.

- (a) To borrow the sum of \$60 000 by way of Bank Overdraft.
- (b) The Overdraft will be liquidated within 2 years.
- (c) The Interest rate applicable will be that applicable from time to time but will not be at a rate higher than that applicable for the short term fixed period loan.
- (d) The purpose of the Overdraft is to provide part cost of the purchase of a front end loader for the Council Quarry the balance of the funding being available from current resources.

The attention of ratepayers is drawn to the following.

- (i) that on or before 6 November 1980 not less than five per cent of the persons on the municipal roll may by writing under their hands, delivered to the Minister together with the sum of \$100 request that the proposal to obtain the advance be submitted to a poll of voters;



- (ii) that the Minister may grant or reject any such request for a poll, and give such directions in respect of the \$100, as he considers appropriate;
- (iii) that if the Minister grants a request for a poll, the provisions of Sections 401 to 406 of the *Local Government Act 1958* shall apply with such modifications as the Minister may direct.

9992

B. PEARL, Shire Secretary

SHIRE OF DEAKIN

LOAN No. 48

*Notice of Intention to Borrow the Sum of \$106 250 for Permanent Works and Undertakings*

Notice is hereby given that the Council of the Shire of Deakin intends to borrow the principal sum hereinafter mentioned on the credit of the general rates of the President, Councillors and Ratepayers of the Shire of Deakin by the grant of mortgage in accordance with the provisions of the *Local Government Acts*, and notice is hereby further given:

- (a) that the amount of the principal sum which it is proposed to borrow is \$106 250;
- (b) the rate of interest is nil;
- (c) the moneys borrowed are to be repayable by five yearly instalments, each of \$26 562.50 on 1 February in each year, and the place at which such moneys are to be repayable is The Department of Youth, Sport and Recreation, Melbourne. The first instalment shall be payable on 1 February 1982;
- (d) the purpose for which the loan is to be applied is: Part Cost of Construction of Indoor Recreation Centre of Tongala—total cost estimated at \$425 000;
- (e) the loan to be liquidated by appropriation out of the municipal fund;
- (f) the plans, specifications and estimate for the cost of such works, and the statement showing the proposed expenditure of the money to be borrowed, are open for inspection at the office of the Council, during office hours.

10044

B. PEARL, Shire Secretary

SHIRE OF DIAMOND VALLEY

LOAN No. 68

*Notice of Intention to Borrow the Sum of \$300 000 for Permanent Works and Undertakings*

Notice is hereby given that the Council of the Shire of Diamond Valley proposes to borrow the principal sum of \$300 000 secured by a charge over the general rates of the municipality, such sum to be raised by the grant of a mortgage in accordance with the provisions of the *Local Government Act 1958*.

1. The maximum rate of interest that may be paid is 12.6 per cent. per annum.

2. The purpose for which the loan is to be applied is:

	\$	\$
<b>Buildings—</b>		
Wahroonga Pre-School (part prov.)	40 600	
Greenhills Basketball Centre (part prov.)	25 900	
	66 500	
<b>Parks—</b>		
Yando Street Dam, Kalparrin Gardens (part prov.)	40 000	
Diamond Creek Reserve (part prov.)	13 000	
	53 000	
<b>Public Works—</b>		
Council Proportion C.R.B. Works	137 000	
<b>Land Purchases—</b>		
Public Open Space Repayments (part prov.)	43 500	
	300 000	

3. The period of the loan shall be 15 years.

4. The moneys borrowed shall be repayable by providing out of the municipal fund half-yearly instalments of \$22 498.84 each including principal and interest on 1 June and 1 December during the currency of the loan. The first instalment shall be payable on 1 June 1981.

5. Such moneys shall be repayable to the State Savings Bank of Victoria, Melbourne.

The plans and specifications and the estimate of the cost of the proposed works and a statement showing the proposed expenditure of the moneys to be borrowed are open for inspection at the office of the Council of the Shire of Diamond Valley, Civic Drive, Greensborough.

9995

B. J. MORGAN, Shire Secretary

SHIRE OF KORUMBURRA

NOTICE OF MAKING A BY-LAW

Notice is hereby given that the Council of Korumburra has, pursuant to the provisions of the *Local Government Act 1958*, made the following By-Law.

By-Law No. 75—Korumburra Municipal Saleyards for the purposes of:

- (1) Regulating the market known as Korumburra Municipal Saleyards and the buildings, stalls, pens and the standings therein and for preventing nuisances or obstructions therein or in the immediate approaches thereto.
- (2) Fixing the days and the hours during each day on which the market shall be held.
- (3) Licensing yards and premises for the sale of livestock within the municipal district and for fixing dues and fees to be paid in respect of such yards and premises.
- (4) Fixing fees and dues payable in respect of the use of the market.
- (5) Regulating the carriers resorting to the market.
- (6) Preventing the sale or exposure for sale of unwholesome provisions in the market.
- (7) Providing for the proper custody and control of livestock in the market; and
- (8) Regulating the use of weighing instruments provided by Council.
- (9) Repealing By-Law No. 64.

Copies of the above By-Law are open for inspection free of charge, during normal office hours at the Municipal Offices, Korumburra.

19 September 1980

9984

D. A. CARTLEDGE, Shire Secretary

SHIRE OF LILLYDALE

LOAN No. 172

*Notice of Intention to Borrow the Sum of \$400 000*

Notice is hereby given that the Council of the Shire of Lillydale proposes to borrow the principal sum of \$400 000 secured by a charge over the general rates of the municipality, such sum to be raised by the grant of a mortgage in accordance with the provisions of the *Local Government Act 1958*.

1. The maximum rate of interest that may be paid is 12.6% per annum.

2. The purpose for which the loan shall be applied is as follows:

	\$
1. Roadworks Ingram Road (to Municipal Tip)	42 000
2. Reconstruction Old Gippsland Road, Maroondah Highway to Old Hereford Road	73 500
3. Reconstruction Main Street, Lillydale west of Railway (north side)	13 000
4. Reconstruction North Road, Maroondah Highway to east of Albert Road	40 000
5. Realignment Killara Road over tributary of Stringy Bark Creek	14 000
6. Lillydale Reserve lower oval, steel rail and post fence around oval	3 600

	\$
7. Reconstruction Parker Road, Old Baker Road to Graham Street, regulate asphalt course and re-seal existing pavement	19 000
8. Sealing McAllister Road, Monbulk, Allandale Road to south of Old Emerald Road	11 000
9. Reconstruction intersection Glasgow/Sheffield Roads	25 000
10. Reconstruction Government Road adjacent to Montrose Primary School	20 000
11. Reconstruction Sheffield Road South, Wild Cherry Road to Currawong Road	15 500
12. Bitumen stabilisation and seal Main Street, Olinda construction access road	10 000
13. Bitumen stabilisation and seal Sheffield Road North, Belvedere Drive to end of Carparking of laneway north side of Hookey Reserve	14 400
14. Carparking of laneway north side of Hookey Reserve	5 000
15. Mooroolbark Heights Reserve, extension of car park	1 000
16. Kilsyth Sports Centre, site works and landscaping	20 000
17. Wonga Park Cricket Club, verandah and pathway fencing of oval, landscaping and car park completion	15 000
18. Mooroolbark Community Centre, security lighting	4 500
19. Morrisons Reserve, construction two additional tennis courts, stage 2	20 000
20. Construction of passing lane Clegg Road at St. Mary's Primary School, low cost construction without kerb and channel	7 500
21. Road reconstruction failure—Greenslopes Drive	10 000
22. Property acquisition, C.W.A. Hall Kalorama (part cost)	8 000
23. Hansen Park Reserve development, complete Reserve including informal car park and pine log barriers	8 000
	400 000

3. The period of the loan shall be fifteen (15) years.

4. The moneys borrowed shall be repayable by providing out of the Municipal Fund thirty (30) half yearly instalments of \$29 998.45 each including principal and interest on 14 May and 14 November during the currency of the loan. The first instalment shall be payable on 14 May 1981.

Such moneys shall be repayable to the Commonwealth Savings Bank, Main Street, Lilydale.

The plans and specifications and estimates of the cost of the works and a statement showing the proposed expenditure of the moneys to be borrowed are open for inspection at the Shire Offices, Anderson Street, Lilydale, 3140.

9999

K. D. WILSON, Shire Secretary

## SHIRE OF MAFFRA

## PROPOSED LOAN No. 69

*Notice of Intention to Borrow the Sum of \$60 000 for Permanent Works and Undertakings*

Notice is hereby given that the Council of the Shire of Maffra proposes to borrow the principal sum of Sixty Thousand Dollars (\$60 000) secured by a charge over the General Rates of the Municipality, such sum to be raised by the grant of a Mortgage in accordance with the Provisions of the *Local Government Act 1958*.

1. The maximum rate of interest that may be paid is 12.6% per annum.

2. The purpose for which the Loan is to be applied is:

	\$
Shire Office, Maffra Building Extensions Part Cost	11 000
Shire Office and Council Chamber Furniture and Equipment	24 000
Boisdale Drainage and Sewerage Scheme Part Cost	25 000
	60 000

3. The period of the Loan shall be Fifteen (15) years.

4. The moneys borrowed shall be repayable by providing out of the Municipal Fund thirty half yearly instalments of approximately \$4 499.77 each, including principal and interest on 1 May and 1 November, during the currency of the Loan. The first instalment shall be payable on 1 May 1981.

5. Such moneys shall be repayable to the Commissioners of the State Savings Bank of Victoria at the Office of the said Commissioners, 233 Collins Street, Melbourne.

6. The plans, specifications and estimate of cost of the proposed works and a statement showing the proposed expenditure of the moneys to be borrowed are open for inspection at the Office of the Council of the Shire of Maffra at Johnson Street, Maffra.

Dated 1 October 1980

9986

J. RENNICK, Shire Secretary

## SHIRE OF OTWAY

## APPOINTMENT OF PROSECUTING OFFICER

Notice is hereby given that the Council of the Shire of Otway has appointed Sergeant Alexander Davidson Thomson, No. 14098, as Prosecuting Officer in lieu of Sergeant Barrie Charles Klemm, No. 11934, retired.

T. R. RICHARDSON, Shire Secretary

Shire Offices, Beech Forest, 3237

9993

## SHIRE OF PAKENHAM

## LOAN No. 90

*Notice of Intention to Borrow the Sum of \$27 000 for Permanent Works and Undertakings*

Notice is hereby given that the Council of the Shire of Pakenham proposes to borrow the principal sum of \$27 000 (Twenty-Seven Thousand Dollars) secured by a charge over the general rates of the Municipality, such sum to be raised by the grant of a Mortgage in accordance with the provisions of the *Local Government Act 1958*.

1. The maximum rate of interest that may be paid is 12.6 per centum per annum.

2. The purpose for which the loan is to be applied is the construction of car parking—North side, Main Street, Pakenham.

3. The period of the loan shall be fifteen (15) years.

4. The moneys borrowed shall be repayable by providing out of the Municipal Fund thirty (30) half-yearly instalments of \$2 024.90 each, including Principal and Interest, on 10 April and 10 October during the currency of the loan. The first instalment shall be payable on 10 April 1981.

5. Such moneys shall be repayable to The Commercial Savings Bank of Australia Limited, Main Street, Pakenham.

The Plans and Specifications and the estimate of the cost of the proposed work and a Statement showing the proposed expenditure of the moneys to be borrowed are open for inspection at the Office of the Council of the Shire of Pakenham, Main Street, Pakenham, during office hours.

9982

B. J. WALLIS, Shire Secretary

## GEELONG WATERWORKS AND SEWERAGE TRUST

Pursuant to section 60 of the *Geelong Waterworks and Sewerage Act 1958* (No. 6263) the Trust has prepared plans to indicate the particulars of sewers and underground works, the construction of which the Trust intends to begin, at a date not less than one month after publication of the notices, in or adjacent to the following locality within the Drainage Area.

Tucker Street, Breakwater, City of Geelong.

Notice is hereby given that the plans indicated are open for public inspection at the Trust's Offices, 61-67 Ryre Street, Geelong, between the hours of 9.00 a.m. and 5.00 p.m. from Monday to Friday (public holidays excepted) by the owners or occupiers of land or premises within the Drainage Area.

10049

L. C. SPITTY, Secretary

## THE BALLARAT SEWERAGE AUTHORITY

Pursuant to Section 119 (2) of the *Sewerage Districts Act 1958* (No. 6368), notice is hereby given of the intention to construct a sewer to provide for a property situated in the vicinity of the following streets:

City of Ballarat—Kline Street, Ballarat East more particularly as shown on maps which are open for inspection at this office between the hours of 8.45 a.m. and 4.30 p.m., Monday to Friday inclusive.

Dated 24 September 1980

B. E. LEACH, Secretary

Water and Sewerage Offices  
Grenville Street South, Ballarat 3350

9990

## DROMANA-ROSEBUD SEWERAGE AUTHORITY

## GENERAL NOTICE

The above mentioned Sewerage Authority having made provision for carrying off the sewage from each and every property which or any part of which is within the sewerage area hereinafter described doth hereby declare that on or after 1 October 1980, each and every property which or any part of which is within the said sewerage area shall be deemed a seweraged property within the meaning of the *Sewerage Districts Act 1958*.

The boundaries of the sewerage area hereinbefore referred to are:

*Declared Area No. 27*

Commencing at the south eastern end of Stawell Street proceed south westerly along the boundary of the Mornington Peninsula Freeway to Park Grove, then north along Park Grove to Latrobe Parade, then along the boundaries of Declared Area No. 18 and 22 to the point of commencement.

*Declared Area No. 29*

Commencing at the intersection of Elwers Road and Keogh Street proceed south westerly along the boundary of the Mornington Peninsula Freeway to the south west corner of No. 8 Carramar Court, then generally north and east along the boundaries of Declared Area Nos. 14 and 17 to the point of commencement.

*Declared Area No. 30*

Commencing at the intersection of Nepean Highway and Arthur Street proceed south-easterly along Arthur Street then south along Francis Street to James Street then south easterly along the eastern boundary of No. 33 James Street, then south westerly along the boundary of the Mornington Peninsula Freeway to McCulloch Street then north along the boundaries of declared area No. 28 to the point of commencement.

By order of the said Sewerage Authority

9998 J. K. BUCHANAN, Chairman  
J. O. WILLIAMS, Secretary

## PORTARLINGTON SEWERAGE AUTHORITY

## GENERAL NOTICE

The abovementioned Sewerage Authority having made provision for carrying off the sewage from each and every property which or any part of which is within the sewerage area hereinafter described doth hereby declare that on and after 30 September 1980 each and every property which or any part of which is within the said sewerage area shall be deemed to be a seweraged property within the meaning of the *Sewerage Districts Act 1958*.

*Sewerage Area No. 3*

The boundaries of the sewerage area hereinbefore referred to are as indicated on a plan which is available for inspection at the Authority's Office, being the Municipal Office, Collins Street, Drysdale.

By order of the said Sewerage Authority

10046 G. W. C. ROBERTS, Chairman  
G. L. PEARCE, Secretary

## DROMANA-ROSEBUD SEWERAGE AUTHORITY

## NOTICE OF INTENTION TO COMMENCE WORKS

The Dromana-Rosebud Sewerage Authority advise that sewer construction works will soon be carried out in the following area:

*Sewer Reticulation Stage 5B (ii)*

The area generally bounded by Gibson Street, Noel Street, Pier Street, the Mornington Peninsula Freeway and Arthur Street.

Any interested person may inspect the plan of works at the Office of the Authority, Nepean Highway, Dromana between 9.00 a.m., and 4.00 p.m., Monday to Friday.

9987

J. O. WILLIAMS, Secretary

## FRANKSTON SEWERAGE AUTHORITY

## COMMENCEMENT OF WORKS

Notice is hereby given that the Frankston Sewerage Authority intends to construct sewers in the Jacksons Road subdivision situated off Jacksons Road, Mount Eliza.

Details of the proposed works are available for inspection at the offices of the Authority, Civic Centre Annexe, 34 Davey Street, Frankston, during normal office hours.

A. H. BUTLER, Secretary

Civic Centre, Annexe  
Frankston, 3199

9996

## OCEAN GROVE SEWERAGE AUTHORITY

## GENERAL NOTICE

The abovementioned Sewerage Authority, having made provision for carrying off the sewage from each and every property which or any part of which is within the sewerage area hereinafter described doth hereby declare that on and after 30 September 1980 each and every property which or any part of which is within the said sewerage area shall be deemed to be a seweraged property within the meaning of the *Sewerage Districts Act 1958*.

*Sewerage Area No. 10*

The boundaries of the sewerage area hereinbefore referred to are as indicated on a plan which is available for inspection at the Authority's Works Office, 77 The Parade, Ocean Grove.

By order of the said Sewerage Authority

10045 W. W. NAIRN, Chairman  
G. L. PEARCE, Secretary

## EUROA SEWERAGE AUTHORITY

## By-Law No. 2

Notice is hereby given that in pursuance of the powers conferred by the *Sewerage Districts Act 1958* as amended, the Euroa Sewerage Authority has made By-Law No. 2 for the purpose of Consents, Licences, Trade Waste, and other matters relating to House Connection Works. Resolution for making and passing the said By-Law was agreed to by the Authority on 6 May 1980.

The By-Law was approved by the Governor in Council on 2 September 1980.

Copy of the By-Law may be inspected during office hours, free of charge at the Authority's Office, 1 Bury Street, Euroa.

## By-Law No. 3

Notice is hereby given that in pursuance of the powers conferred by the *Sewerage Districts Act 1958* as amended, the Euroa Sewerage Authority has made By-Law No. 3 relating to Fees for House Drainage, Plans, Alterations, Penalties for Non-Compliance with Authority's By-Laws and Licence Fees. Resolution for making and passing the said By-Law was agreed to by the Authority on 6 May 1980.

The By-Law was approved by the Governor in Council on 2 September 1980.

Copy of the By-Law may be inspected during office hours, free of charge at the Authority's Office, 1 Bury Street, Euroa.

10048

A. D. ESSON, Secretary

## MOE SEWERAGE AUTHORITY

Plans have been prepared for the laying of sewer mains to serve the following streets in the City of Moe.

Job 111/153 Purvis Street, Cemetery Road and Morello Court.

Job 111/156 Market Street.

Job 111/159 Wirraway Street Deviation.

The plans are available for inspection during normal working hours at the office of the Authority, Kirk Street, Moe.

Dated 23 September 1980

9989

A. DEWAR, Secretary

## UPPER YARRA VALLEY AND DANDENONG RANGES AUTHORITY

## NOTICE OF EXHIBITION OF A REGIONAL STRATEGY PLAN

Notice is hereby given that the Upper Yarra Valley and Dandenong Ranges Authority having prepared pursuant to the provisions of section 12 of the *Upper Yarra Valley and Dandenong Ranges Authority Act 1976*, a Regional Strategy Plan for that area covered by the Municipal Districts of the Shires of Healesville, Lillydale, Sherbrooke, and Upper Yarra and having considered a report thereon from the Town and Country Planning Board have varied such Regional Strategy Plan and pursuant to the provisions of Section 14 (11) of the said Act has adopted that Regional Strategy Plan, as so varied.

Pursuant to the provisions of Section 14 (13) of the said Act, the Upper Yarra Valley and Dandenong Ranges Authority does hereby give notice that the Regional Strategy Plan as varied and adopted by it is available for public inspection at the following places:

The Offices of the Upper Yarra Valley and Dandenong Ranges Authority, Old Melbourne Road, Croydon North (Melway Ref: 37/E6);

The Offices of the Town and Country Planning Board, 235 Queen Street, Melbourne;

The Shire Offices, Shire of Healesville, 231 Maroondah Highway, Healesville;

The Shire Offices, Shire of Lillydale, Anderson Street, Lillydale;

The Shire Offices, Shire of Sherbrooke, Glenfern Road, Upwey; and

The Shire Offices, Shire of Upper Yarra, Warburton Highway, Yarra Junction.

Written representations with respect to matters contained within the Regional Strategy Plan will be accepted by the Upper Yarra Valley and Dandenong Ranges Authority, P.O. Box 104, Lillydale up until 2 March 1981, and any such representations may state that the person/s making the representations wishes to be heard with respect thereto.

1 October 1980

9981

GARY M. PRATTLEY

## APPLICATION FOR DISPOSAL OF LAND PURSUANT TO AN ACT TO PROVIDE FOR THE ABOLITION OF STATE AID TO RELIGION ACT 391—FIRST SCHEDULE

I, the Right Reverend Maxwell McNee Thomas of Wangaratta in the State of Victoria, Bishop of the Church of England Diocese of Wangaratta head or authorised representative of the Denomination known as The Church of England in the Diocese of Wangaratta in Victoria with the consent of the Church of England Trusts Corporation for the Diocese of Wangaratta of Wangaratta aforesaid which is entitled to be registered as the Trustee of the land described in the sub-joined Statement of Trusts hereby applies to the Governor of the State of Victoria for leave to dispose of the said land by means and for the purposes mentioned in the said Statement of Trusts and I hereby certify that the said land was promised or reserved as a site for the Church of England purposes on 18 December 1865.

2. That the Church of England Trusts Corporation for the Diocese of Wangaratta is entitled to be registered as the only Trustee of the said land.

3. There are no buildings erected on the said land.

4. The only person entitled to minister or occupy same is the Incumbent for the Parish of Bright namely the Reverend George Barry Browne of The Rectory, Clyde Street, Myrtleford.

Dated 21 February 1980

Signed sealed and delivered by the said The Right Reverend Maxwell McNee Thomas in Victoria in the presence of W. H. Glen.

The Common Seal of The Church of England Trusts Corporation for the Diocese of Wangaratta was hereunto affixed, by authority of the trustees—

MAXWELL M. THOMAS, Trustee  
FRANK RICKARD, Trustee  
M. NELSON, Trustee

(SEAL)

## STATEMENT OF TRUST

*Description of the Land*—626 square metres, Township of Wandiligong, Parish of Bright, County of Delatite being Crown Allotment 35e. Commencing at a point bearing 185 deg. 11 min. 51.50 metres from the south-western angle of Crown Allotment 35c, bounded thence by lines bearing 91 deg. 27 min. 17.90 metres, 181 deg. 27 min. 35 metres and 271 deg. 27 min. 17.90 metres; and thence by a road bearing 1 deg. 27 min. 35 metres to the point of commencement.

*Name of Trustee*—The Church of England Trusts Corporation for the Diocese of Wangaratta of Wangaratta aforesaid.

*Power of Disposition*—Power to sell lease mortgage or exchange all or any part of such land subject to the approval of the Bishop of Wangaratta for the time being or during the absence of the Bishop from the Diocese or the vacancy of the See to the approval of the person for the time being administering the affairs thereof. The land until otherwise disposed of to be held for the purpose for which it was granted or reserved by the Crown.

*Purposes to which Proceeds of Disposition are to be Applied*—To such purposes of the Church of England as may be agreed upon by:

- (1) The Bishop or during his absence from his See or during the vacancy thereof by the person or persons for the time being administering the affairs of the Diocese.
- (2) The Trustees of the Church of England Trusts Corporation for the Diocese of Wangaratta.
- (3) The Minister entitled to occupy the aforesaid land.

Messrs Mal. Ryan, Jackson & Glen of 9 High Street, Mansfield, solicitors for the applicant 9997

I, Roseanne May Stewart of 16 McConchie Avenue East Kew in the State of Victoria Nursing Aide do hereby give notice that I have assumed the name and intend henceforth upon all occasions and at all times to use and be called and known by the surname of Stewart in lieu of the surname of Dunlevy and to use the name Roseanne May Stewart as my full name and that such intended change is endorsed by a Deed Poll dated 25 August 1980 and deposited in the Office of the Registrar-General of the State of Victoria and numbered 90461.

Dated 25 September 1980

ROSEANNE MAY STEWART  
(formerly Roseanne May Dunlevy)

McSwineys, solicitors, 57 Reid Street, Wangaratta 10054

Notice is heretofore given that the partnership heretofore subsisting between Geoffrey Victor White and Kathleen Mavis White formerly carrying on business as Builders at 9 Devenish Avenue, Montrose under the name of G. V. & K. M. White has been dissolved as from 1 July 1980. Kathleen Mavis White will not be responsible for any debts undertaken by the said Geoffrey Victor White on account of the partnership or purportedly on account of G. V. & K. M. White from that date. 10001

The partnership between David Patrick Hynes & Dianne Margaret Hynes both of 8 Conniston Street, Wendouree and Gilbert Alan Coad & Rita Merle Coad both of 902 Sherrard Street, Ballarat which previously conducted the business of "El Toro Menswear" at Shop 6, 9 Victoria Street, Ballarat has been dissolved as from 31 May 1980 and the said business is now being conducted at the same premises by the new partnership of Gilbert Alan Coad and Rita Merle Coad both of 902 Sherrard Street, Ballarat.

RAMSAY, GAUNT & FRASER, 41 Lydiard Street South, Ballarat 10002

Notice is hereby given that the partnership conducted by Franco Cristiano, and Lina Cristiano both of 54 Vine Street, Moonee Ponds and Angelo Bellani and Caterina Bellani both of 39 Murial Street, Niddrie and Lucio Troyer and Tonia Troyer both of 1 Patrick Street, Thomastown under the firm name of B.C.T. Cabinets was dissolved on 1 August 1980. 10003

Notice is hereby given that the partnership business carried on by Norman John Wilkie and Gordon Frederick Wilkie under the firm name of N. J. & G. F. Wilkie, Builders, at Church Street, Kilmore and Powlett Street, Kilmore has been dissolved by mutual consent from 31 August 1980 and further take notice that Gordon Frederick Wilkie will continue to carry on business under his own name at "Illira", Wandong Road, Kilmore until further notice. Dated 24 September 1980

NORMAN JOHN WILKIE  
GORDON FREDERICK WILKIE

Ian B. Still & Co., solicitors, 32 Sydney Street, Kilmore, Vic. 3601 10004

Take notice that the partnership of Vincenzo Trimboli, Felecia Trimboli and Carmelo Trimboli carried on under the firm of W. White's Body Works at 36 Parer Road, Airport West has been dissolved as from 12 September 1980 and that the said Vincenzo Trimboli and Felecia Trimboli shall not be responsible for any debts incurred in the name of the said W. White's Body Works from the said date.

V. TRIMBOLI  
F. TRIMBOLI  
C. TRIMBOLI

10050

Notice is hereby given that the Partnership heretofore subsisting between Gary Norman Viccars and Betty Alma Viccars both of 3 Bosanquet Avenue Newtown and Leslie Pickersgill and Elizabeth Jean Pickersgill both of 8 Pembroke Street Corio carrying on the business of "Victorian Kyokushin Karate Headquarters" and "Malop Street Health Studio" at 159 Malop Street Geelong has been dissolved by mutual consent from 22 August 1980 and that the said businesses will continue to be carried on by the said Gary Norman Viccars and the said Betty Alma Viccars.

ANDREW SENIA & ASSOC., solicitors, 94 Gheringhap Street, Geelong, Vic. 3220 10051

Notice is hereby given that the Partnership heretofore subsisting between Kaj Vingborg Mikkelsen of 148 Bloomfield Road Noble Park and Raymond Stewart Blaney of 9 Austin Court Sunbury carrying on business under the style or firm name of Wattle Promotional Production has been dissolved as from 1 March 1980 so far as concerns the said Raymond Stewart Blaney who retired from the said firm. The said Kaj Vingborg Mikkelsen shall continue the said business.

K. J. MIKKELSEN  
R. S. BLANEY

Barker, Harty & Co., solicitors, of 459 Collins Street, Melbourne. Tel. No. 62 0011 10052

Notice is hereby given that the partnership heretofore subsisting between Terrence John Barker and Trevor John Gaw at 503 Barry Road, Broadmeadows and 33 Norval Crescent, Coolaroo under the style or firm name Barker & Gaw Transport has been dissolved as from 1 July 1980 the said Trevor John Gaw who retires from the said firm. All debts due to and owing by the said firm will be received and paid by Terrence John Barker who will carry on the business under the style or firm of Barker Transport. 10053

C. RUTHERFORD & CO. PTY. LIMITED (IN VOLUNTARY LIQUIDATION)

NOTICE CONVENING FINAL MEETING, PURSUANT TO SECTION 272 OF THE COMPANIES ACT 1961

Pursuant to Section 272 of the Companies Act 1961 a general meeting of members of the above mentioned company will be held at 522 Clayton Road, Clayton, Victoria on Monday 10 November 1980 at 9.00 a.m. for the purpose of having an account laid before them showing the manner in which the winding up has been conducted and the property disposed of and of hearing any explanation that may be given by the liquidator.

Dated 29 September 1980

10085 W. P. HARRINGTON, Liquidator

The Companies Act 1961

VARNDENE PTY. LTD. (IN VOLUNTARY LIQUIDATION)

NOTICE CONVENING FINAL MEETING OF THE COMPANY PURSUANT TO SECTION 272 (1)

Notice is hereby given that the Final Meeting of Members of the abovenamed Company will be held at the offices of Touche Ross & Co., 12th Floor, 440 Collins Street, Melbourne on 5 November 1980 at 11.00 a.m. for the purpose of laying before the Meeting an account showing how the winding up has been conducted and the property of the Company has been disposed of and giving any explanation thereof.

Dated 1 October 1980

G. O. HARRISON, Liquidator

Touche Ross & Co., chartered accountants, 440 Collins Street, Melbourne, 3000 10086

The Companies Act 1961

GEORGE LOVITT & CO. PTY. LTD. (IN LIQUIDATION)

NOTICE CONVENING FINAL MEETING OF THE COMPANY PURSUANT TO SECTION 272 (1)

Notice is hereby given that the Final Meeting of Members of the abovenamed Company will be held at the offices of Touche Ross & Co., 10th Floor, 440 Collins Street, Melbourne on 5 November 1980 at 10.00 a.m. for the purpose of laying before the Meeting an account showing how the winding up has been conducted and the property of the Company has been disposed of and giving any explanation thereof.

Dated 1 October 1980

G. O. HARRISON, Liquidator

Touche Ross & Co., chartered accountants, 440 Collins Street, Melbourne, 3000 10087

Companies Act 1961, Section 272 (2)—In the matter of GARDINOL CHEMICAL COMPANY (AUSTRALASIA) PTY. LTD. —Notice of Final Meeting

Notice is hereby given that pursuant to Section 272 of the Companies Act, the final meeting of the members of the abovenamed company will be held at 14th floor, 447 Collins Street, Melbourne at 10.00 a.m. on 5 November 1980 for the purpose of having an account laid before it showing the manner in which the winding up has been conducted and the property of the company disposed of and hearing any explanation that may be given by the liquidator.

Dated 23 September 1980

R. E. CHANCELLOR AND L. N. ANDERSON, joint and several liquidators, 447 Collins Street, Melbourne, 3000 10088

CLAYMEL INVESTMENTS PTY. LTD. (IN LIQUIDATION)

NOTICE OF RESOLUTION PURSUANT TO SECTION 254 (2) (b) OF THE COMPANIES ACT

At a General Meeting of the Company held on 24 September 1980 the following Special Resolution was duly passed:—

"That the Company be wound up voluntarily and that Noel Henry Forscutt of 53 Alice Street, Clayton be and is hereby appointed the Liquidator for the purposes of such winding up."

ARTHUR PHILLIPS & JUST, solicitors, 367 Collins Street, Melbourne 10099

## Unclaimed Moneys Act 1962

Register of Unclaimed Moneys held by the—

Name of Owner in Records and Last Known Address	Total Amount Due to Owner	Description of Unclaimed Moneys	Date when Amount first became Due
<b>Australian Register</b>			
<b>COMALCO LIMITED</b>			
Ahuja, Mary (Mrs) and Ahuja, Rakesh c/o Dept of Foreign Affairs, (Peking Bag), Canberra, A.C.T.	35.55	Dividend	20.10.78
Allinson, Robert John, c/o McWilliam E. (Miss), 28 Birdwood St, Zilimere, Qld.	10.47	"	"
Amor, Murray William and Amor, Lee Isobel (Miss), 52 Moreton St, Lakemba, N.S.W.	31.02	"	"
Arnold, J. V. (Miss), 154 Wellington Rd, Kew	38.73	"	"
Barr, Frank Robson and Jessica (Mrs), Unit 9, 30 Middle Cres, Brighton	15.43	"	"
Barrie, Lynette Blyth (Mrs), 3 Glebe Ave, Cheltenham	31.02	"	"
Boys, Trevor Lloyd, 118 Franklin St, George Town, Tas.	46.45	"	"
Brown, Robyn May (Miss), 240 Gondoon St, Gladstone, Qld.	46.45	"	"
Carrall, John Kenneth, 60 South Rd, Brighton	31.02	"	"
Clark, Anna Williams (Mrs), 43 Nelson Rd, Lindfield, N.S.W.	35.55	"	"
Coughlin, Ruby Stella (Mrs), 56 Mandurah Tce, Mandurah, W.A.	15.43	"	"
Cox, Timothy Harvey, 61 The Point Rd, Woolwich N.S.W.	17.64	"	"
Cranfield, James Stephen, 87 Milton St, Elwood	31.02	"	"
Crossley, John James, 20 Ullet Rd, Liverpool 8, U.K.	62.04	"	"
Dalton, Thomas Joseph, c/o Bank of N.S.W., 102 Payneham Rd, St Peters, S.A.	155.10	"	"
Darragh, Roderick Selwyn, 6 Hiscock St, Chadstone	31.02	"	"
Davies, Brian Kenneth, 73 New North Rocks Rd, North Rocks, N.S.W.	15.43	"	"
Dietz, Rachel (Mrs), c/o Bertram, V. J. (Mrs), 72 Herberton Rd, Atherton, Qld.	12.41	"	"
Diffen, Patricia Margaret (Miss), 81 Roseberry St, Inglewood, W.A.	31.02	"	"
Drewett, Pamela Elizabeth (Miss), Apartment 1705, 190 Cherry Hill Circle, London, Ontario, N6H 2M3, Canada	71.26	"	"
Duncan, Sydney Walter Henry and Evelyn Marie Joan (Mrs), 68 Griffin Cres, Manning, W.A.	46.45	"	"
Edwards, Richard Bettington, Suite 903, 75 Elizabeth St, Sydney, N.S.W.	56.64	"	"
Edwards, William Allen, 18th St, Mary Kathleen, Qld	93.06	"	"
Evans, Jacqueline Sheelagh (Mrs), 12 Pier St, Gladstone, Qld.	93.06	"	"
Fallanca, Francesca (Miss), 67 Main Rd, Clayton	31.02	"	"
Faulkner, William Alfred James, 8 Winston St, Launceston, Tas.	46.45	"	"
Fellows, Jan Leslie, 17 Waterson Dr, Sun Valley, Gladstone, Qld.	53.35	"	"
Field, Alan Ronald, 5 Hillcrest Pde, Miami, Qld.	31.02	"	"
Garrick, David, Colehayes, Otterton, Budleigh Salterton, Devon, U.K.	155.10	"	"
Gellert, Harry Ernst, 14 Rymer St, Carina, Qld.	35.55	"	"
Gerlach, Hartwig and Jeanne (Mrs), 149 Croydon Ave, Croydon Park, N.S.W.	46.45	"	"
Gho, Lian Chin, 57 Warburton Rd, Canterbury	310.19	"	"
Golbey, Adrian, 34 Worcester Ave, Birstall, Leicester, LE 4 4GQ, U.K.	93.06	"	"
Gourley, Patricia Margaret (M/s), 70A Bridge St, Toowoomba, Qld.	62.04	"	"
Green, Kenneth William, c/o M. J. Williamson, P.O. Box 25, Beaconsfield, Tas.	46.45	"	"
Greenup, Edwin Francis, 23 Kimbar Units, Marine Pde, Southport, Qld.	31.02	"	"
Hall, Judith Anne (Mrs), P.O. Box 273, Tom Price, W.A.	31.02	"	"
Harari, Joseph, 20 Albert Rd, Carnegie	35.55	"	"
Harkness, John, 3/16 Lower Boyle St, Cremorne, N.S.W.	15.43	"	"
Harrington, Timothy J., G.P.O. Box 2395, Sydney, N.S.W.	17.64	"	"
Helbig, Judith Marie (Mrs), P.O. Mary Kathleen, Qld.	106.98	"	"
Herridge, David Francis, 61 The Esplanade, Nedlands, W.A.	35.55	"	"
Hitchcock, Eileen Frances P. (Mrs), 99 Walker St, Bundaberg, Qld.	201.01	"	"
Howe, Roy Duncalfe and Daphne, Joyce (Mrs), 9 Hillhouse Rd, Templestowe	35.55	"	"
Howell, Kenneth Gordon, 33 Railway Pde, Fairfield, N.S.W.	46.45	"	"
Huggins, Donald Rhodes (Dr), c/o World Health Organisation, P.O. Box 2550, Kuala Lumpur, Malaysia	17.64	"	"
Hutton, Judith Bertha (M/s), 19 Montagu St, Lenah Valley, Tas.	15.43	"	"
Ide, Wendy Elspeth, (Mrs), 132 Henley Marine Rd, Drummoyne, N.S.W.	31.02	"	"
James, George Patrick and George William Berry, 16 York Tce, Mosman Park, W.A.	15.43	"	"
Jenner, Edward John, 81 Roseberry Rd, Guildford, N.S.W.	53.35	"	"
Johnson, Carmen Louise (Miss), c/o David V. Johnson, SMQ, Rocky Point, Weipa, Qld.	46.45	"	"
Johnson, David Graham, 4/34 Allambee Ave, Camberwell	31.02	"	"
Kassianos, Aristomenis, 110 Dawson St, Lismore, N.S.W.	15.43	"	"
Kavanagh, Colin Wardrop, 78 Stead St, South Melbourne	31.02	"	"
Keogh, Margaret Olivia (Miss), Eustace Price and Eustace Julian, Unit 1, 9 Mary St, Kew	15.43	"	"
King, Bridget (Miss), 15 Glendale St, Surrey Hills	31.02	"	"
Kirkwood, Margaret (Mrs), P.O. Box 14, Bell, Qld.	35.55	"	"
Kohn, Jan, P.O. Box 1286, Townsville, Qld.	46.45	"	"
Koolwyk, Wilhelmina Van (Mrs), 52 Adelaide St, George Town, Tas.	46.45	"	"
Lane, Elizabeth Hilda (Miss), Mt Eccles, Leongatha	31.02	"	"
Lasica, Margaret Renee (Mrs), 74 New St, Brighton	35.55	"	"
Layne, Geoffrey Peter, Apartment 608, 2313 Lake Shore, Blvd W., Toronto 4, Ontario, Canada	31.02	"	"
Lazaretos, James, 126 South Pde, Auburn, N.S.W.	12.41	"	"
Lenton, Anthony John, Mendham Farm, P.O. Box 129, Mazabuka, Zambia	35.55	"	"
Levy, Anthony, 58 Summerset Rd, Duffy, A.C.T.	31.02	"	"
Lohrey, Margaret Hadden (Mrs) and David Kenneth, 210 Brooklyn St, Beaconsfield, Tas.	35.55	"	"

## Unclaimed Moneys Act 1962

## Register of Unclaimed Moneys held by the—

Name of Owner on Books and Last Known Address	Total Amount Due to Owner	Description of Unclaimed Money	Date when Amount first became Payable
\$			
COMALCO LIMITED—continued			
Lyons, Douglas John, 436 West Tamar Rd, Riverside North, Tas.	46.45	Dividend	20.10.78
MacDiarmid, Hugh Melrose, P.O. Box 56, North Adelaide, S.A.	31.02	"	"
MacGregor, Ian Angus, c/o Comalco Pastorial, 321 Sheridan St, Cairns, Qld.	31.02	"	"
MacKenzie, Rodney Alfred, 132 Off St, Gladstone, Qld.	46.45	"	"
Malvezzi, Giovanni, 6 Parc De Bearn, Saint-Cloud 92, France	310.19	"	"
Mankey, Judith Ann (Mrs), Lot 16 Bungarra Cres, Moorebank, N.S.W.	62.04	"	"
Marinelli, Elio, Via Dante 70, 09010, Portoscuso (CA), Sardinia	46.45	"	"
Mason, David Johnson, 100 Barkly St, Carlton	31.02	"	"
Mason, Phillip Alec, 7 Treherne St, Mayfield, Tas.	46.45	"	"
McCosker, Paul James, c/o Patrick Partners, G.P.O. Box 2850, Sydney, N.S.W.	35.55	"	"
McGinness, John Henry and Mary Patricia, P.O. Box 543, Arawa, P.N.G.	35.55	"	"
McLaren, Peter John, 9 Paterson Cres, George Town, Tas.	31.02	"	"
McMurdo, Vivian and Alma Mary (Mrs), 13 Dalton St, Cairns, Qld.	46.45	"	"
Metherall, Elizabeth Anne (Miss), "Leighlands", Tooradin North	15.43	"	"
Millar, Graeme Douglas (estate of), c/o Archer Hall Waterhouse, P.O. Box 87, Launceston, Tas.	46.45	"	"
Milner, Diane Kaye (Mrs), 3 Berean St, Launceston East, Tas.	46.45	"	"
Nye, Hilda Esther (Miss), P.O. Box 4, Buderim, Qld.	15.43	"	"
O'Brien, Edward James, 6/65 Moray St, New Farm, Qld.	93.06	"	"
Perry, Cyril James, 3 Charles St, Abbotsford	62.04	"	"
Pickering, Frank Leslie, c/o Hong Kong and Shanghai Banking Corp., P.O. Box 64, Hong Kong	31.02	"	"
Puescher, Thomas, Unit 10, 6 Munro St, Glenelg North, S.A.	46.45	"	"
Reed, Stephen Reginald Wells, Unit 14, 614 Pacific Hwy, Chatswood, N.S.W.	26.60	"	"
Reymondier, George, 9 Leawarra St, Engadine, N.S.W.	15.43	"	"
Robinson, Alan Richard, 36 Fryett St, Waverley, Tas.	31.02	"	"
Rowland, Christina (Mrs), 123 Chifley St, Smithfield, N.S.W.	53.35	"	"
Sawtschenko, Nikolay, 37 The Strand, George Town, Tas.	53.35	"	"
Serich, Suzanne Margaret (Mrs), Flat 2, 3 Stimson Gve, Somerton Park, S.A.	35.55	"	"
Simpson, Linda Mary (Mrs), 42 Lavington St, Coorparoo, Qld.	46.45	"	"
Stagg, Andrew James, 41 Halifax St, Garbutt, Qld.	31.02	"	"
Straka, Paul Stephen, 43 Wood St, Manly, Qld.	15.43	"	"
Taylor, Janet Mary (Mrs), P.O. Box 112, Buderim, Qld.	31.05	"	"
Thomas, Ann (Miss), 15 Oakbank Gve, Pascoe Vale	62.04	"	"
Thompson, David Frederick, 14 Greenhill Way, Hurstwood Lane, Haywoods Heath, Sussex, U.K.	71.26	"	"
Tober, Dirk, P.O. Box 32, Dover, Tas.	15.43	"	"
Twyford, John Douglas and Bettie Marion (Mrs), 12 Lodge Ave, Old Toongabbie, N.S.W.	31.02	"	"
Tyson, Rosalene Margaret (Mrs), 24 Simpson St, Northcote	53.35	"	"
Van, Nunen, David John 16 Berringar Rd, Valentine, N.S.W.	15.43	"	"
Van Nunen, Sheryl Anne (Miss), 16 Berringar Rd, Valentine, N.S.W.	15.43	"	"
Veldhuis, Willy John, 3 Reserve St, Launceston, Tas.	15.43	"	"
Vogle, Marcia Therese (Miss), G.P.O. Box 1359, Brisbane, Qld.	63.04	"	"
Wade, Merrilyn Jayne (Mrs), 3/55 Liverpool St, Rose Bay, N.S.W.	62.04	"	"
Waldron, Keith Warwick and Glenn Royce Donal, 124 Weatherall Rd, Cheltenham	11.17	"	"
Wartski, Henry Hanna Stephen, 306 Carlisle St, Balaclava	30.05	"	"
Williams, Christine Isobel (Mrs), Swallow St, Slade Point, Qld.	11.71	"	"
Williams, Lesley Jane (Mrs), 136 La Perouse St, Griffith, A.C.T.	31.02	"	"
Williams, Paul Stanley and Pauline Margaret (Mrs), 1 North Tce, Seaton, S.A.	15.43	"	"
Willis, Laurel Jean (Mrs), 24 Nott St, Balwyn	93.06	"	"
Wilson, Hugh Vincent, 86 Arndell St, MacQuarie, A.C.T.	31.02	"	"
Wood, Peggy Alice (Mrs), Flat 6, 135 Mitchell St, North Ward, Townsville, Qld.	106.98	"	"
Yeo, Lee Cheng (Miss), 35 Jalan Tupai, Singapore 10, Singapore	35.55	"	"
<i>New Zealand Register</i>			
Andrews, Pamela (Miss), 13 Ngaio Rd, Kelburn 5, Wellington, N.Z.	\$N.Z.	"	"
Annett, Harold Edward (Dr), 21 Berkley Ave, Hamilton, N.Z.	33.65	"	"
Atea Farms Limited, c/o A. J. Thompson, Tramway Rd, Hamilton, N.Z.	38.57	"	"
Baird, Denis Williams, 24 Connaught Tce, Brooklyn, Wellington, N.Z.	35.65	"	"
Bamford, Graeme, Alan Ward and Michael Kemp, 82 Castor Cres, Porirua, N.Z.	33.65	"	"
Bamford, Graeme, Alan Ward and Michael Kemp, 82 Castor Cres, Porirua, N.Z.	16.74	"	"
Bellamy, Geoffrey Maxfield, c/o A.N.Z. Group Ltd., 517 Customhouse Quay, Wellington, N.Z.	33.65	"	"
Carroll, Gaye Nannette (Mrs), 19 William Fraser Cres, Auckland 5, N.Z.	33.65	"	"
Davies, Peter Simon Tom, Pukenui, Rd 2, Whakatane, N.Z.	33.65	"	"
Frost, Edward George Alfred, P.O. Box 2174, Wellington, N.Z.	16.74	"	"
Grohmann, Robert, P.O. Box 6180, Te Aro, Wellington, N.Z.	18.84	"	"
Hebenton, Janice Mary (Mrs), 3 Newcombe Cres, Karori, Wellington, N.Z.	19.14	"	"
Hutchings, Mary (Mrs), 46 Penrose St, Lower Hutt, N.Z.	38.57	"	"
Jones, Lawrence Edward, 7 St Marks Rd, Remuera 5, N.Z.	33.65	"	"
Karsten, Wayne Martyn, 19 Kandy Cres, Ngaio, Wellington, N.Z.	33.65	"	"
Leighton, Helen Annie Sheila (Mrs), 43 Waitoa Rd, Hataitai, Wellington 3, N.Z.	33.65	"	"
MacGibbon, Angus John, Eastern Bush RD 1, Otautau, Southland, N.Z.	38.57	"	"

## Unclaimed Moneys Act 1962

Register of Unclaimed Moneys held by —

Name of Owner on Books and Last Known Address	Total Amount Due to Owner	Description of Unclaimed Moneys	Date when Amount first became Payable
\$NZ			
COMALCO LIMITED—continued			
Maginness, William Stephen Langtry, Eiffelton, Rd 4, Ashburton, N.Z.	33.65	Dividend	20.10.78
Mead, Geoffrey Arthur, 9 Alice St, Invercargill, N.Z.	33.65	"	"
Pirie, Murray William, 24 Bidwill St, Wellington, N.Z.	33.65	"	"
Polson, Muriel Doreen (Mrs), 15 Wiggins St, Christchurch 8, N.Z.	38.57	"	"
Sharples, Harry, 53 Miro St, Masterton, N.Z.	38.57	"	"
Woodward, Marian Mary (Mrs), Flat 5b, Kimberley Rd, Epsom, Auckland 3, N.Z.	38.57	"	"

9209

Companies Act 1961, Section 272  
 NANASSY NOMINEES PTY. LTD. (IN LIQUIDATION)  
 NOTICE OF FINAL MEETING

Notice is hereby given that the final meeting of the members and creditors of the abovenamed company will be held at my offices on Monday, 3 November 1980 at 11.00 a.m. for the purpose of laying before the meetings an account showing how the winding up has been conducted and the property of the company disposed of and giving any explanation thereof.

Dated 24 September 1980

V. R. DYE, Liquidator

V. R. Dye & Co., chartered accountants, 536 Whitehorse Road, Mitcham, 3132 10089

Companies Act 1961, Section 272  
 DOSIS PTY. LTD. (IN LIQUIDATION)  
 DRECKIG PTY. LTD. (IN LIQUIDATION)

## NOTICE OF FINAL MEETINGS

Notice is hereby given that the final meetings of the members of the abovenamed companies will be held at my offices on Monday, 3 November 1980 at 11.15 a.m. and 11.30 a.m. respectively, for the purpose of laying before the meetings an account showing how the winding up has been conducted and the property of the companies disposed of and giving any explanation thereof.

Dated 24 September 1980

G. W. LONG, Liquidator

V. R. Dye & Co., chartered accountants, 536 Whitehorse Road, Mitcham, 3132 10090

Companies Act 1961—In the matter of the Subsidiaries of  
 JOHN W. STAMP PTY. LTD. (in Liquidation)—Notice of  
 Meeting of Creditors

Notice is hereby given that pursuant to section 260 (1) of the Companies Act 1961, a meeting of creditors of each of the companies listed below will be held at Coopers & Lybrand, 461 Bourke Street, Melbourne on 9 October 1980 at 10.00 a.m. in the forenoon.

Each company having convened a meeting of its members for the same day for the purpose of considering a special resolution that the company be wound up voluntarily.

Stampco Holdings Pty. Ltd.  
 Stampco Engineering Pty. Ltd.  
 Stampco Nominees Pty. Ltd.  
 PMATS Pty. Ltd.

Dated 29 September 1980

G. F. TUCKER, Secretary of each of the abovenamed Companies

Coopers & Lybrand, chartered accountants, 461 Bourke Street, Melbourne, Vic. 3000 10092

The Companies Act 1961  
 MORTON-NAPIER PTY. LTD. (IN MEMBERS VOLUNTARY  
 LIQUIDATION)

Notice is hereby given that at an Extraordinary General Meeting of Members of the abovenamed Company held on 17 September 1980 it was resolved that the Company be wound up voluntarily and that Geoffrey Ormond Harrison of 12th Floor, 440 Collins Street, Melbourne be appointed Liquidator.

Notice is also given that after 21 days from this date, I shall proceed to distribute the assets. All Creditors having any claims against the Company should furnish particulars of their claims by that date, otherwise I shall proceed to distribute the assets without regard to their claims.

Dated 24 September 1980

G. O. HARRISON, Liquidator

Touche Ross & Co., chartered accountants, 440 Collins Street, Melbourne 3000 10098

Companies Act 1961  
 SAFETY SEAL PTY. LTD. (IN LIQUIDATION)

Notice is hereby given that at an extraordinary general meeting of the members of the abovenamed company held on Tuesday, 23 September 1980 it was resolved that the Company be wound up voluntarily and at a meeting of creditors held later the same day it was resolved that for such purpose Victor Raymond Dye of 536 Whitehorse Road, Mitcham be appointed liquidator.

Notice is also given that after 21 days from this date I shall proceed to distribute the assets of the Company. All creditors who have any claim against the company should furnish particulars of the same by that date otherwise I shall proceed to distribute the assets without regard to their claim.

Dated 24 September 1980

V. R. DYE, Liquidator

V. R. Dye & Co., chartered accountants, 536 Whitehorse Road, Mitcham 3132 10100

Companies Act 1961  
 AQUILINA HOLDINGS PTY. LTD. (IN LIQUIDATION)  
 NOTICE CONVENING FINAL MEETING OF CREDITORS OF THE  
 COMPANY, PURSUANT TO SECTION 272 (1)

Notice is hereby given that the Final Meeting of Members and Creditors of the abovenamed Company will be held at the offices of E. P. Taylor, Chartered Accountant, 583 Hampton Street, Hampton on 5 November 1980 at 9.30 a.m. for the purpose of laying before the meeting an account showing how the winding up has been conducted and the property disposed of and of giving any explanations thereof.

Dated 24 September 1980

10007

E. P. TAYLOR, Liquidator



The Companies Act 1961—In the matter of CHEVIC PTY. LTD.—Members Winding Up

Notice is hereby given that at an Extraordinary General Meeting of the above company duly convened and held at 144 Esplanade, Brighton, in the State of Victoria on 29 September 1980 the following resolution was proposed and passed as a special resolution:—

"That the company be wound up voluntarily."

Dated 29 September 1980

K. J. RUSSELL, Liquidator

Coopers & Lybrand, chartered accountants, 18th Floor,  
461 Bourke Street, Melbourne, Vic. 3000 10101

O'CONNELL & KERR PROPRIETARY LIMITED

Notice is hereby given, pursuant to section 254 (2) (b) of the Companies Act 1961, that at an extraordinary general meeting of members of O'Connell and Kerr Proprietary Limited duly convened and held at 352 Macaulay Road, Kensington, on 17 September 1980, the special resolution set out below was duly passed—

"That the company be liquidated by voluntary liquidation and that Mr M. J. Scott, of Deloitte Haskins and Sells, 461 Bourke Street, Melbourne be appointed to act as liquidator."

Dated 29 September 1980

10102

M. J. SCOTT, Liquidator

DRA-MAC ENGINEERING PROPRIETARY LIMITED

Notice is hereby given, pursuant to section 254 (2) (b) of the Companies Act 1961, that at an extraordinary general meeting of members of Dra-Mac Engineering Proprietary Limited duly convened and held at 244 Dorcas Street, South Melbourne on 17 September 1980, the special resolution set out below was duly passed—

"That the company be liquidated by voluntary liquidation and that Mr M. J. Scott of Deloitte Haskins and Sells, 461 Bourke Street, Melbourne be appointed to act as liquidator."

Dated 29 September 1980

10103

M. J. SCOTT, Liquidator

D.U. INVESTMENT MANAGEMENT PTY. LTD.

At an Extraordinary General Meeting of the abovenamed Company duly convened and held at 5 Thaxted Road, Murrumbidgee on 13 September 1980 the following Resolution was duly passed as a Special Resolution:

(1) That the Company be wound up voluntarily.

(2) That Mr George Hardy, of 5 Thaxted Road, Murrumbidgee be and is hereby appointed liquidator of the Company.

My office is situated at c/- H. & H. Guest & Associates Pty. Ltd., 230 Balaclava Road, Caulfield.

Dated 13 September 1980

10010

G. HARDY, Liquidator

The Companies Act 1961—In the matter of MOLONY IMPORTS PTY. LTD. (in Liquidation)—Creditors' Winding Up

Notice is hereby given that at an Extraordinary General Meeting of members of Molony Imports Pty. Ltd. duly convened and held at 500 Collins Street, Melbourne in the State of Victoria on 22 September 1980, the following resolution was proposed and passed as a Special Resolution—

"That the Company be wound up voluntarily in accordance with the provisions of the Act relating to a creditors voluntary winding up."

Notice is also given that all creditors having any claim against the Company should furnish particulars of same within twenty-one days otherwise I shall proceed to distribute the assets, without regard to their claim.

Dated 22 September 1980

J. D. ADAMS, Liquidator

C/- Parkhill Lithgow & Gibson, 500 Collins Street,  
Melbourne 10093

No. 84—27130/80—4

Companies Act 1961

GESMOR CONSTRUCTIONS PTY. LTD.  
PESAKQUEEN PTY. LTD.  
PESAKSOUTH PTY. LTD.  
PESAKVIC PTY. LTD.  
PESAKWEAR PTY. LTD.  
PESAKMAN PTY. LTD.  
PESAKHOLD PTY. LTD.  
FIVE RIVERS PTY. LTD.  
ONE RIVER PTY. LTD.  
SIX RIVERS PTY. LTD.  
TEN RIVERS PTY. LTD.  
ABEINACE HOLDINGS PTY. LTD.  
S.A.C. (ST. JAMES) PTY. LTD.  
L.I. INVESTMENTS PTY. LTD.  
G.H.F. PTY. LTD.  
G. W. WONG & COMPANY PTY. LTD.  
ARRAL INVESTMENTS PTY. LTD.  
TUCHMAN HOLDINGS PTY. LTD.  
TUCHMAN MANUFACTURING PTY. LTD.  
MOTU PTY. LTD.  
DEBRIA PTY. LTD.  
FIRST MDT PTY. LTD.  
SECOND MDT PTY. LTD.  
THIRD MDT PTY. LTD.  
FOURTH MDT PTY. LTD.  
FIFTH MDT PTY. LTD.  
SIXTH MDT PTY. LTD.  
SEVENTH MDT PTY. LTD.  
EIGHTH MDT PTY. LTD.  
NINTH MDT PTY. LTD.  
TENTH MDT PTY. LTD.  
TAMUZREIT PTY. LTD.  
TAMUZAVSTMET PTY. LTD.

(ALL IN LIQUIDATION)

Notice is hereby given that pursuant to Section 272 of the Companies Act 1961 final meetings of the members of each of the abovenamed Companies will be held at 31 Talbot Avenue, Balaclava on Thursday 30 October 1980 commencing at 8.30 a.m.

Business—To receive the Liquidator's Accounts.

Dated 24 September 1980

10009

C. BAKER, Liquidator

Companies Act 1961; in the matter of J. FULTON PTY. LTD. (in Liquidation)

Notice is hereby given that pursuant to Section 272 of the Companies Act 1961, the final meeting of the members and creditors of the company will be held at Suite 2, 162 Albert Road, South Melbourne, on 5 November 1980 at 4.00 p.m. for the purpose of laying before the meeting the account of the winding up and any explanation thereof.

Dated 23 September 1980

N. K. CUTHBERT, Liquidator

R. G. CAMERON, Liquidator

W. Marshall & Associates, chartered accountants, Suite 2, 162 Albert Road, South Melbourne. 3205 10008

The Companies Act 1961—In the matter of ANDER TRADING COMPANY PTY. LTD. (in Liquidation)—Creditors' Winding Up

Notice is hereby given that at an Extraordinary General Meeting of members of Ander Trading Company Pty. Ltd. duly convened and held at 500 Collins Street, Melbourne in the State of Victoria on 22 September 1980, the following resolution was proposed and passed as a Special Resolution—

"That the Company be wound up voluntarily in accordance with the provisions of the Act relating to a creditors voluntary winding up."

Notice is also given that all creditors having any claim against the Company should furnish particulars of same within twenty-one days otherwise I shall proceed to distribute the assets, without regard to their claim.

Dated 22 September 1980

J. D. ADAMS, Liquidator

C/- Parkhill Lithgow & Gibson, 500 Collins Street,  
Melbourne 10094

**Companies Act 1961—In the matter of MAGNIBOX PTY. LIMITED—Notice of Meeting of Creditors**

Notice is hereby given that pursuant to section 260 (1) of the Companies Act 1961, a meeting of creditors of Magnibox Pty. Ltd. will be held at 2nd Floor, 461 Bourke Street, Melbourne on 9 October 1980 at 10.30 a.m.

The company having convened a meeting of its members for the same day for the purpose of considering a special resolution that the company be wound up voluntarily.

Dated 24 September 1980

J. G. PACE, Secretary

Coopers & Lybrand, chartered accountants, 461 Bourke Street, Melbourne, Vic. 3000 10091

**Companies Act 1961, Section 254 (2) (b)  
EAST COAST SAWMILLS PTY. LTD. (IN LIQUIDATION)**

Notice is hereby given that at an Extraordinary General Meeting of the members of the abovenamed company held on 22 September 1980 it was resolved that the company be wound up voluntarily, and that Mr John McKenzie Hilliard, 17th Floor, 500 Bourke Street, Melbourne, be appointed liquidator.

Notice is also given that after 21 days from this date, I shall proceed to distribute the assets. All creditors having any claims against the company should furnish particulars of same by that date, otherwise I shall proceed to distribute the assets without regard to their claim.

Dated 24 September 1980

JOHN MCKENZIE HILLIARD, 17th Floor, 500 Bourke Street, Melbourne, Vic., 3000 10095

**The Companies Act 1961, Section 254 (2) and Regulation 54  
B.M.R. AIRCONDITIONING PTY. LTD. (IN LIQUIDATION)**

Notice is hereby given that at an Extraordinary General Meeting of the Members of the abovenamed Company held on 15 September 1980, it was resolved that the Company be wound up voluntarily, and at a meeting of creditors held on the same day pursuant to section 206, it was resolved that for such purpose, Messrs. Robert Eastaugh Ramsay and John Martin Walsh, both of 499 St. Kilda Road, Melbourne, Chartered Accountants, be appointed Liquidators, to act jointly and severally.

Notice is also given that after twenty-one days from this date we shall proceed to distribute the assets. Take notice that the Liquidators have fixed Wednesday, 22 October 1980, as a day on or before which creditors are to prove their debts or claims and to establish any entitlement they may have to priority under Section 292 or be excluded from the benefit of any distribution made before such debts are proved or, as the case may be, from objecting to such distribution.

Dated 1 October 1980

R. E. RAMSAY, Liquidator  
J. M. WALSH, Liquidator

Wallace, McMullin & Smail, chartered accountants 10096

**The Companies Act 1961—In the matter of PETER KLASCHEN PTY. LTD. (in Liquidation)**

Notice is hereby given that at an Extraordinary General Meeting of the Members of the abovenamed Company held on Thursday, 18 September 1980 it was resolved that the Company be wound up voluntarily and at a Meeting of Creditors held on the same day, it was resolved that for such purposes Robert Molesworth Hobill Cole, of 440 Collins Street, Melbourne, Chartered Accountant, be appointed Liquidator.

Notice is also given that after twenty-one (21) days from this date, I shall proceed to distribute the assets. All creditors having any claim against the Company should furnish particulars of same by that date, otherwise I shall proceed to distribute the assets without regard to their claim.

Dated 26 September 1980

R. M. H. COLE, Liquidator

R. M. H. Cole, chartered accountant, 440 Collins Street, Melbourne, Vic., 3000 10097

**MILLIARA NOMINEES PTY. LTD. (IN VOLUNTARY LIQUIDATION)**

**NOTICE OF FINAL MEETING**

Notice is hereby given that pursuant to Section 272 of the Companies Act 1961 the final meeting of the members of the Company will be held at the office of Scree, Nixon, Watt & Co., 257 Collins Street, Melbourne on Friday 7 November 1980, at 9.45 a.m. for the purpose of having an account laid before them showing the manner in which the winding up had been conducted and hearing any explanations that may be given by the liquidator.

Dated 24 September 1980

N. W. CURWOOD, Liquidator

Scree, Nixon, Watt & Co., 257 Collins Street, Melbourne 10066

**In the matter of the Companies Act 1961, Section 260; and in the matter of ZANARD STEEL FABRICATION PTY. LTD.—Notice of Meeting of Creditors**

Notice is hereby given that a meeting of the creditors of Zanard Steel Fabrication Pty. Ltd. will be held at the offices of Hungerford Hancock & Offner, 10th Floor, 44 Market Street, Melbourne, in the State of Victoria, at 10.30 a.m. on Thursday, 9 October 1980.

**Agenda**

1. To consider and pass Special Resolution pursuant to Section 261 (1) of the Companies Act 1961.

2. To appoint a Committee of Inspection.

3. To fix the Liquidators' remuneration.

Dated 30 September 1980

W. LEAVEY, Director

Hungerford Hancock & Offner, 44 Market Street, Melbourne 3000, telephone 614 1200

A person is not entitled to vote as a creditor at the meeting unless he has lodged with the Chairman of the meeting a proof of debt which he claims to be due to him from the company. 10071

In the Supreme Court of Victoria—1980 No. Co. 11422—In the matter of the Companies Act 1961; and in the matter of MERWIN PASTORAL CO. PTY. LTD.—Before the Honourable Mr Justice McInerney, Thursday 4 September 1980

This petition presented 20 May 1980 coming on for hearing 4 September 1980 upon hearing Mr A. J. McDonald of Counsel on behalf of the abovenamed company (hereinafter referred to as "the Company"), there being no appearance by or on behalf of any other person and upon reading the said petition, the affidavits of Lindsay James Yeo sworn 23 May 1980, and of Lindsay James Yeo sworn 14 August 1980, and of Lewis Richard Davies-Graham sworn 29 August 1980, and of Lindsay James Yeo sworn 1 September 1980, each filed herein, and the exhibits thereto respectively and the Order of Master Bergere made herein 22 August 1980 this court doth order: That the reduction of capital resolved upon and proposed to be affected by the Special Resolution passed at the extraordinary general meeting of the shareholders of the Company held on 6 November 1979 (being the Special Resolution referred to in paragraph 5 of the Petition) be and the same hereby is confirmed, and doth declare that the amount of the share capital of the Company as altered by this Order is \$50 000 divided into 100 000 shares of 50 cents each all of which have been issued and are fully paid up and doth order:

1. That an office copy of this Order shall be lodged with the Registrar of Companies on or before 26 September 1980.

2. That this Order shall be published once in the *Government Gazette* and once in *The Age* newspaper within one month of the lodging of the said office copy with the Registrar of Companies.

By the Court

C. P. JACOBS, Master

Darvall & Hambleton, of 147 Collins Street, Melbourne, solicitors for the company 10073

In the Supreme Court of Victoria—1980 No. Co. 11552—  
In the matter of the Companies Act 1961; and in the  
matter of J. W. CORNISH HOLDINGS PTY. LTD.—Advertisement  
of Petition

Notice is hereby given that a petition for the winding up of the abovenamed Company by the Supreme Court was, on 19 September 1980, presented by Oceania-Universal Paving Co. Pty. Ltd. And that the said petition is directed to be heard before the Court sitting at Melbourne at the hour of 10.30 o'clock in the forenoon on 23 October 1980; and any creditor or contributory of the said company desiring to support or oppose the making of an Order on the said petition may appear at the time of the hearing by himself or his counsel for that purpose; and a copy of the petition will be furnished to any creditor or contributory of the said company requiring the same by the undersigned on payment of the regulated charge for the same.

The Petitioner's address is 10 Ewing Street, Brunswick.

The Petitioner's solicitors are Mills, Oakley & McKay, of 10 Powlett Street, East Melbourne.

MILLS, OAKLEY & MCKAY

NOTE—Any person who intends to appear on the hearing of the said Petition must serve on or send by post to the abovenamed Petitioner or to its solicitors notice in writing of his intention so to do. The notice must state the name and address of the person, or if a firm, the name and address of the firm, and must be signed by the person or firm, or his or their solicitor (if any) and must be served, or, if posted, must be sent by post in sufficient time to reach the abovenamed not later than four o'clock in the afternoon of 22 October 1980 (the day before the day appointed for the hearing of the Petition or the Friday preceding the day appointed for the hearing of the Petition if such day is a Monday or a Tuesday following a public holiday). 10074

Companies Act 1961

28 HOPE STREET PROPRIETARY LIMITED (IN  
VOLUNTARY LIQUIDATION)

NOTICE OF FINAL MEETING OF MEMBERS

Notice is hereby given that pursuant to section 272 of the Companies Act 1961, the final meeting of members of the Company will be held at the offices of Messrs Darvas, Hodson & Stainmagen, 8 Aberdeen Road, Prahran on Monday, 27 October 1980, at 9 a.m. for the purpose of laying before the meeting an account showing how the winding up has been conducted and the property has been disposed of and giving any explanation thereof.

Dated 23 September 1980

10005

J. STAINMAGEN, Liquidator

In the matter of the Companies Act 1961; and in the  
matter of KANKO ENGINEERING CO. PTY. LTD. (in Liquidation)

Notice is hereby given that pursuant to section 272 of the Companies Act 1961 the final meeting of the members of the Company will be held at 361 Nepean Highway, Mordialloc on 18 November 1980 at 9.30 a.m., for the purpose of laying before the meeting the account of the winding up and any explanation thereof.

Dated 7 October 1980

10006

E. J. BATES, Liquidator

Companies Act 1961—In the matter of SKYLINE CARAVAN  
& MARINE SALES PTY. LTD.—Notice of Meeting of Creditors pursuant to section 260

Notice is hereby given that a meeting of creditors of the abovenamed company will be held at the office of Orr, Martin & Waters, Top Floor, 460 Bourke Street, Melbourne, on Thursday, 9 October 1980, at 11.00 a.m. the company having convened an extraordinary general meeting of its members for the same day for the purpose of considering a Special Resolution that the company be wound up voluntarily.

Dated 24 September 1980

R. GRAHAM, Director

Orr, Martin & Waters, chartered accountants, 460 Bourke Street, Melbourne, 3000. Telephone 602 1644 10035

In the Supreme Court of Victoria—In the matter of the  
Companies Act 1961; and in the matter of BELDON  
PHOTOGRAPHICS PROPRIETARY LIMITED

Notice is hereby given that a petition for the winding up of the abovenamed Company by the Supreme Court was on 23 September 1980 presented by Eric John Unger, Deputy Commissioner of Taxation of the Commonwealth of Australia and that the said petition is directed to be heard before the Court sitting at the Fifteenth Court, Law Courts, Lonsdale Street, Melbourne at the hour of 10.30 o'clock in the forenoon on 16 October 1980 and any creditor or contributory of the said company desiring to support or oppose the making of an order on the said petition may appear at the time of hearing by himself or his Counsel for the purpose; and a copy of the said petition will be furnished to any creditor or contributory of the said company requiring the same by the undersigned on payment of the regulated charge for the same.

The Petitioner's official address is 350 Collins Street, Melbourne.

The Petitioner's Solicitor is C. R. Morrison, Acting Solicitor for the Commonwealth of 99 Queen Street, Melbourne.

C. R. MORRISON

NOTE—Any person who intends to appear on the hearing of the said petition must serve on or send by post to the abovenamed C. R. Morrison, notice in writing of his intention so to do. The notice must state the name and address of the person, or, if a firm, the name and address of the firm, and must be signed by the person or firm, or his, or their solicitor (if any), and must be served, or, if posted, must be sent by post in sufficient time to reach the abovenamed not later than 4.00 o'clock in the afternoon of 15 October 1980. 10075

Form 92

The Companies Act 1961, Section 272 (1)

Company Regulations

KAYGEE NOMINEES PTY. LTD. (IN LIQUIDATION)

NOTICE OF MEETING OF CREDITORS AND CONTRIBUTORS

Notice is hereby given that a final meeting of the creditors and contributors of Kaygee Nominees Pty. Ltd. (in Liquidation) will be held at the office of Orr, Martin & Waters, Top Floor, 460 Bourke Street, Melbourne, on Friday 31 October 1980, at 11.00 a.m. to receive the liquidator's account of his acts and dealings and of the conduct of the winding up and of hearing any explanations thereof.

Dated 26 September 1980

ROBERT A. WATERS, Liquidator

Orr, Martin & Waters, chartered accountants, 460 Bourke Street, Melbourne, 3000. Telephone 602 1644 10036

Companies Act 1961

MARCRYLIC PTY. LTD. (UNDER OFFICIAL MANAGEMENT)

Notice is hereby given that a meeting of Creditors of the company has been called for the purposes of considering and if thought fit passing a special resolution that the company be wound up.

The meeting will be held at the office of Harle & Associates of 145 Parker Street, Templestowe at 9.30 a.m. on Tuesday 7 October 1980.

10040

G. R. MURPHY, Official Manager

In the matter of the Companies Act 1961, as amended, and  
in the matter of BROOKONG PASTORAL CO. PTY. LTD.—  
Final Meeting

Notice is hereby given that in accordance with section 272 (2) of the Companies Act 1961, as amended, a final general meeting of the Company will be held at the office of the liquidator 520 Swift Street, Albury, New South Wales on 7 November 1980 at 3.00 p.m. for the purpose of having laid before it by the liquidator, an account showing how the winding up has been conducted and the property of the Company disposed of.

Dated 24 September 1980

10041

J. S. COUGHLAN, Liquidator

In the Supreme Court of Victoria—In the matter of the Companies Act 1961; and in the matter of FOURSTAR FASHIONS PTY. LTD.

Notice is hereby given that a petition for the winding up of the abovenamed Company by the Supreme Court was on 23 September 1980 presented by Eric John Unger, Deputy Commissioner of Taxation of the Commonwealth of Australia and that the said petition is directed to be heard before the Court sitting at the Fifteenth Court, Law Courts, Lonsdale Street, Melbourne at the hour of 10.30 o'clock in the forenoon on 16 October 1980 and any creditor or contributory of the said company desiring to support or oppose the making of an order on the said petition may appear at the time of hearing by himself or his Counsel for the purpose; and a copy of the said petition will be furnished to any creditor or contributory of the said company requiring the same by the undersigned on payment of the regulated charge for the same.

The Petitioner's official address is 350 Collins Street, Melbourne.

The Petitioner's Solicitor is C. R. Morrison, Acting Solicitor for the Commonwealth of 99 Queen Street, Melbourne.

C. R. MORRISON

NOTE—Any person who intends to appear on the hearing of the said petition must serve on or send by post to the abovenamed C. R. Morrison, notice in writing of his intention so to do. The notice must state the name and address of the person, or, if a firm, the name and address of the firm, and must be signed by the person or firm, or his, or their solicitor (if any), and must be served, or, if posted, must be sent by post in sufficient time to reach the abovenamed not later than 4.00 o'clock in the afternoon of 15 October 1980. 10076

In the Supreme Court of Victoria—In the matter of the Companies Act 1961; and in the matter of GOLDEN HARVEST PTY. LTD.

Notice is hereby given that a petition for the winding up of the abovenamed Company by the Supreme Court was on 23 September 1980 presented by Eric John Unger, Deputy Commissioner of Taxation of the Commonwealth of Australia and that the said petition is directed to be heard before the Court sitting at the Fifteenth Court, Law Courts, Lonsdale Street, Melbourne at the hour of 10.30 o'clock in the forenoon on 16 October 1980 and any creditor or contributory of the said company desiring to support or oppose the making of an order on the said petition may appear at the time of hearing by himself or his Counsel for the purpose; and a copy of the said petition will be furnished to any creditor or contributory of the said company requiring the same by the undersigned on payment of the regulated charge for the same.

The Petitioner's official address is 350 Collins Street, Melbourne.

The Petitioner's Solicitor is C. R. Morrison, Acting Crown Solicitor for the Commonwealth of 99 Queen Street, Melbourne.

C. R. MORRISON

NOTE—Any person who intends to appear on the hearing of the said petition must serve on or send by post to the abovenamed C. R. Morrison, notice in writing of his intention so to do. The notice must state the name and address of the person, or, if a firm, the name and address of the firm, and must be signed by the person or firm, or his, or their solicitor (if any), and must be served, or, if posted, must be sent by post in sufficient time to reach the abovenamed not later than 4.00 o'clock in the afternoon of 15 October 1980. 10077

The Companies Act 1961

DEVIZES PTY. LTD. (IN VOLUNTARY LIQUIDATION)

Notice is hereby given that the undermentioned Special Resolution was passed at the extraordinary general meeting of Devizes Pty. Ltd. held on 22 September 1980.

"That the company be voluntarily wound up in accordance with the Companies Act."

10015

JOHN T. BROWN, Liquidator

In the Supreme Court of Victoria—In the matter of the Companies Act 1961; and in the matter of PARKWAY HOLDINGS PROPRIETARY LIMITED

Notice is hereby given that a petition for the winding up of the abovenamed Company by the Supreme Court was on 23 September 1980 presented by Eric John Unger, Deputy Commissioner of Taxation of the Commonwealth of Australia and that the said petition is directed to be heard before the Court sitting at the Fifteenth Court, Law Courts, Lonsdale Street, Melbourne at the hour of 10.30 o'clock in the forenoon on 16 October 1980 and any creditor or contributory of the said company desiring to support or oppose the making of an order on the said petition may appear at the time of hearing by himself or his Counsel for the purpose; and a copy of the said petition will be furnished to any creditor or contributory of the said company requiring the same by the undersigned on payment of the regulated charge for the same.

The Petitioner's official address is 350 Collins Street, Melbourne.

The Petitioner's Solicitor is C. R. Morrison, Acting Crown Solicitor for the Commonwealth of 99 Queen Street, Melbourne.

C. R. MORRISON

NOTE—Any person who intends to appear on the hearing of the said petition must serve on or send by post to the abovenamed C. R. Morrison, notice in writing of his intention so to do. The notice must state the name and address of the person, or, if a firm, the name and address of the firm, and must be signed by the person or firm, or his, or their solicitor (if any), and must be served, or, if posted, must be sent by post in sufficient time to reach the abovenamed not later than 4.00 o'clock in the afternoon of 15 October 1980. 10078

SATU PTY. LTD. (IN LIQUIDATION)  
NOTICE OF FINAL MEETING

Notice is hereby given, in pursuance of section 272 of the Companies Act 1961, that a Final Meeting of Creditors of Satu Pty. Ltd. (in Liquidation) will be held at the offices of J. N. Cooke, Foley & Co., 3rd Floor, A.M.P. Building, 17 Lydiard Street North, Ballarat, on 31 October 1980 at 10.00 a.m., for the purpose of having an account laid before it showing the manner in which the winding up has been conducted and the property of the Company disposed of, and hearing any explanations that may be given by the Liquidator.

Dated 24 September 1980

KEVIN FOLEY, Liquidator

J. N. Cooke, Foley & Co., public accountants, 3rd Floor, A.M.P. Building, 17 Lydiard Street North, Ballarat; 3350 10065

Companies Act 1961, Section 254 (2)

GOODY-GOODY PTY. LTD.

Notice is hereby given that at an Extraordinary Meeting of Members of the abovenamed Company held on Friday, 19 September 1980, the following special resolutions were duly passed:

"That as Goody-Goody Pty. Ltd., could not pay its debts as and when they fell due, that the Company should be wound up voluntarily."

"That David Henry Scott and Kenneth Wayne Lamb, Registered Company Liquidators be appointed Liquidators, to act jointly or severally for the purpose of winding up the affairs of the Company."

At a meeting of creditors held the same day, our appointment as Liquidators was confirmed.

Notice is also given that all creditors having any claims against the Company should furnish particulars of such claims to the undersigned within twenty-one (21) days, otherwise we shall proceed to distribute the assets without regard to their claim.

D. H. SCOTT, Liquidator

K. W. LAMB, Liquidator

Scott and Lamb, public accountants, 325 Warrigal Road, Burwood, 3125. Telephone: 288 5911 10014

In the Supreme Court of Victoria—In the matter of the Companies Act 1961; and in the matter of WINSUN PTY. LTD.

Notice is hereby given that a petition for the winding up of the abovenamed Company by the Supreme Court was on 23 September 1980 presented by Eric John Unger, Deputy Commissioner of Taxation of the Commonwealth of Australia and that the said petition is directed to be heard before the Court sitting at the Fifteenth Court, Law Courts, Lonsdale Street, Melbourne at the hour of 10.30 o'clock in the forenoon on 16 October 1980 and any creditor or contributory of the said company desiring to support or oppose the making of an order on the said petition may appear at the time of hearing by himself or his Counsel for the purpose; and a copy of the said petition will be furnished to any creditor or contributory of the said company requiring the same by the undersigned on payment of the regulated charge for the same.

The Petitioner's official address is 350 Collins Street, Melbourne.

The Petitioner's Solicitor is C. R. Morrison, Acting Crown Solicitor for the Commonwealth of 99 Queen Street, Melbourne.

C. R. MORRISON

NOTE—Any person who intends to appear on the hearing of the said petition must serve on or send by post to the abovenamed C. R. Morrison, notice in writing of his intention so to do. The notice must state the name and address of the person, or, if a firm, the name and address of the firm, and must be signed by the person or firm, or his, or their solicitor (if any), and must be served, or if posted, must be sent by post in sufficient time to reach the abovenamed not later than 4.00 o'clock in the afternoon of 15 October 1980.

10079

The Victorian Companies Act 1961  
SCUBAIR DISCOUNTS PTY. LTD.

NOTICE OF INTENTION OF VOLUNTARY LIQUIDATION

Notice is hereby given that Scubair Discounts Pty. Ltd., by special resolution passed at an extraordinary meeting of Shareholders, held at 21 Vale Street, Reservoir on 23 September 1980 did resolve that the necessary action be taken in the voluntary winding up of the Company.

10011

P. D. GILBERT, Liquidator

Companies Act 1961, Section 254 (2) (b)  
PAKENHAM CLOSE PTY. LTD.

Notice is hereby given that at an Extraordinary General Meeting of the abovenamed company duly convened and held at Flat 8, 5 Pakenham Street, Blackburn on 18 September 1980, the following special resolution was duly passed:

"That the Company be wound up as a members' voluntary winding up and that William George Thornhill of 2 Katrina Street, Doncaster be appointed liquidator for the purposes of such winding up."

Dated 18 September 1980

10012

W. G. THORNHILL, Liquidator

Companies Act 1961—In the matter of CALMAC TRADING Co. PTY. LTD. (in Liquidation)

Notice is hereby given that at an extraordinary Meeting of the Members of the abovenamed Company held on 22 September 1980 it was resolved that the Company be wound up voluntarily and at a Meeting of Creditors held on the same day pursuant to section 260, it was resolved that for such purpose Mr E. T. Bent of 144 Jolimont Road, East Melbourne be appointed Liquidator.

Notice is also given that after 21 days from this date I shall proceed to distribute the assets. All creditors having any claims against the Company should furnish particulars of same by that date, otherwise I shall proceed to distribute the assets without regard to their claim.

Dated 23 September 1980

E. T. BENT, Liquidator

Bent & Cogle, public accountants, 144 Jolimont Road, East Melbourne 10013

In the Supreme Court of Victoria—In the matter of the Companies Act 1961; and in the matter of DANDY TILES PTY. LTD.

Notice is hereby given that a petition for the winding-up of the abovenamed Company by the Supreme Court was on 23 September 1980 presented by Eric John Unger, Deputy Commissioner of Taxation of the Commonwealth of Australia and that the said petition is directed to be heard before the Court sitting at the Fifteenth Court, Law Courts, Lonsdale Street, Melbourne at the hour of 10.30 o'clock in the forenoon on 23 October 1980 and any creditor or contributory of the said company desiring to support or oppose the making of an order on the said petition may appear at the time of hearing by himself or his Counsel for the purpose; and a copy of the said petition will be furnished to any creditor or contributory of the said company requiring the same by the undersigned on payment of the regulated charge for the same.

The Petitioner's official address is 350 Collins Street, Melbourne.

The Petitioner's Solicitor is C. R. Morrison, Crown Solicitor for the Commonwealth of 99 Queen Street, Melbourne.

C. R. MORRISON

NOTE—Any person who intends to appear on the hearing of the said petition must serve on or send by post to the abovenamed C. R. Morrison notice in writing of his intention so to do. The notice must state the name and address of the person, or, if a firm, the name and address of the firm, and must be signed by the person or firm, or his, or their solicitor (if any), and must be served, or if posted, must be sent by post in sufficient time to reach the abovenamed not later than 4.00 o'clock in the afternoon of 22 October 1980.

10080

In the Supreme Court of Victoria—In the matter of the Companies Act 1961; and in the matter of NOVA CANVAS PTY. LTD.

Notice is hereby given that a petition for the winding-up of the abovenamed Company by the Supreme Court was on 23 September 1980 presented by Eric John Unger, Deputy Commissioner of Taxation of the Commonwealth of Australia and that the said petition is directed to be heard before the Court sitting at the Fifteenth Court, Law Courts, Lonsdale Street, Melbourne at the hour of 10.30 o'clock in the forenoon on 23 October 1980 and any creditor or contributory of the said company desiring to support or oppose the making of an order on the said petition may appear at the time of hearing by himself or his Counsel for the purpose; and a copy of the said petition will be furnished to any creditor or contributory of the said company requiring the same by the undersigned on payment of the regulated charge for the same.

The Petitioner's official address is 350 Collins Street, Melbourne.

The Petitioner's Solicitor is C. R. Morrison, Crown Solicitor for the Commonwealth of 99 Queen Street, Melbourne.

C. R. MORRISON

NOTE—Any person who intends to appear on the hearing of the said petition must serve on or send by post to the abovenamed C. R. Morrison notice in writing of his intention so to do. The notice must state the name and address of the person, or, if a firm, the name and address of the firm, and must be signed by the person or firm, or his, or their solicitor (if any), and must be served, or if posted, must be sent by post in sufficient time to reach the abovenamed not later than 4.00 o'clock in the afternoon of 22 October 1980.

10081

In the Supreme Court of Victoria—In the matter of the Companies Act 1961; and in the matter of SHELBY INVESTMENTS PTY. LTD.

Notice is hereby given that a petition for the winding-up of the abovenamed Company by the Supreme Court was on 23 September 1980 presented by Eric John Unger, Deputy Commissioner of Taxation of the Commonwealth of Australia and that the said petition is directed to be heard before the Court sitting at the Fifteenth Court,

Law Courts, Lonsdale Street, Melbourne at the hour of 10.30 o'clock in the forenoon on 23 October 1980 and any creditor or contributory of the said company desiring to support or oppose the making of an order on the said petition may appear at the time of hearing by himself or his Counsel for the purpose; and a copy of the said petition will be furnished to any creditor or contributory of the said company requiring the same by the under-signed on payment of the regulated charge for the same.

The Petitioner's official address is 350 Collins Street, Melbourne.

The Petitioner's Solicitor is C. R. Morrison, Crown Solicitor for the Commonwealth of 99 Queen Street, Melbourne.

C. R. MORRISON

NOTE—Any person who intends to appear on the hearing of the said petition must serve on or send by post to the abovenamed C. R. Morrison notice in writing of his intention so to do. The notice must state the name and address of the person, or, if a firm, the name and address of the firm, and must be signed by the person or firm, or his, or their solicitor (if any), and must be served, or, if posted, must be sent by post in sufficient time to reach the abovenamed not later than 4.00 o'clock in the afternoon of 22 October 1980. 10082

In the Supreme Court of Victoria—In the matter of the Companies Act 1961; and in the matter of RAKAL PTY. LTD.

Notice is hereby given that a petition for the winding-up of the abovenamed Company by the Supreme Court was on 23 September 1980 presented by Eric John Unger, Deputy Commissioner of Taxation of the Commonwealth of Australia and that the said petition is directed to be heard before the Court sitting at the Fifteenth Court, Law Courts, Lonsdale Street, Melbourne at the hour of 10.30 o'clock in the forenoon on 23 October 1980 and any creditor or contributory of the said company desiring to support or oppose the making of an order on the said petition may appear at the time of hearing by himself or his Counsel for the purpose; and a copy of the said petition will be furnished to any creditor or contributory of the said company requiring the same by the under-signed on payment of the regulated charge for the same.

The Petitioner's official address is 350 Collins Street, Melbourne.

The Petitioner's Solicitor is C. R. Morrison, Crown Solicitor for the Commonwealth of 99 Queen Street, Melbourne.

C. R. MORRISON

NOTE—Any person who intends to appear on the hearing of the said petition must serve on or send by post to the abovenamed C. R. Morrison notice in writing of his intention so to do. The notice must state the name and address of the person, or, if a firm, the name and address of the firm, and must be signed by the person or firm, or his, or their solicitor (if any), and must be served, or, if posted, must be sent by post in sufficient time to reach the abovenamed not later than 4.00 o'clock in the afternoon of 22 October 1980. 10083

In the Supreme Court of Victoria—In the matter of the Companies Act 1961; and in the matter of P. & M. CAMPBELL BUILDERS PROPRIETARY LIMITED

Notice is hereby given that a petition for the winding-up of the abovenamed Company by the Supreme Court was on 23 September 1980 presented by Eric John Unger, Deputy Commissioner of Taxation of the Commonwealth of Australia and that the said petition is directed to be heard before the Court sitting at the Fifteenth Court, Law Courts, Lonsdale Street, Melbourne at the hour of 10.30 o'clock in the forenoon on 23 October 1980 and any creditor or contributory of the said company desiring to support or oppose the making of an order on the said petition may appear at the time of hearing by himself or his Counsel for the purpose; and a copy of the said petition will be furnished to any creditor or contributory of the said company requiring the same by the under-signed on payment of the regulated charge for the same.

The Petitioner's official address is 350 Collins Street, Melbourne.

The Petitioner's Solicitor is C. R. Morrison, Crown Solicitor for the Commonwealth of 99 Queen Street, Melbourne.

C. R. MORRISON

NOTE—Any person who intends to appear on the hearing of the said petition must serve on or send by post to the abovenamed C. R. Morrison notice in writing of his intention so to do. The notice must state the name and address of the person, or, if a firm, the name and address of the firm, and must be signed by the person or firm, or his, or their solicitor (if any), and must be served, or, if posted, must be sent by post in sufficient time to reach the abovenamed not later than 4.00 o'clock in the afternoon of 22 October 1980. 10084

ALAN SUTHERLAND FINLAYSON, late of 25 Tashinny Court, Toorak, in the State of Victoria, retired school-master

Creditors, next of kin and others having claims in respect of the estate of the deceased (who died on 19 July 1980) are required by The Perpetual Executors and Trustees Association of Australia Limited of 50 Queen Street, Melbourne, to send particulars of their claims to the said Company by 2 December 1980 after which date it will convey or distribute the assets, having regard only to the claims of which the Company then has notice. 10059

WILLIAM RAVEN, 178/76 Canning Street, North Melbourne

Dependants, legal personal representatives and others having claims under the Carlton and United Brewers Employees' Superannuation Scheme to the benefit on the life of the above-named who died on 11 September 1980 are required by the Trustees of the Scheme, Messrs Philip Renton Power, Patrick Charles Oliver Stone and Timothy Noel Plant all of 16 Bouverie Street, Carlton Victoria to send particulars to them by 5 December 1980 after which date the Trustees may distribute the benefit, having regard only to the claims of which they then have notice.

"Dependants" within the meaning of the Trust Deed means the wife widow and children of the deceased and any other persons who in the opinion of the Trustees are dependent upon the deceased.

Dated 1 October 1980

10060 J. G. CROSSLAND, Secretary to the Trustees

IAN McPHERSON LOONEY, late of 311 Creswick Road, Ballarat, retired boiler maker, DECEASED (who died on 18 April 1980)

Creditors, next of kin and all other persons having claims against the estate of the said deceased are required by the Executor The Union-Fidelity Trustee Company of Australia Limited of 100 Exhibition Street Melbourne to send detailed particulars of their claims in respect of the said property to the said Executor care of the said Company of 101 Lydiard Street North, Ballarat on or before 1 December 1980 after which date it will proceed to distribute the estate having regard only to the claims of which it then has notice.

Dated 1 October 1980

RAMSAY, GAUNT & FRASER, solicitors, of 41 Lydiard Street South, Ballarat 10068

VOLDEMARS PAKALNIETIS, late of 917 Barkly Street, Ballarat, gentleman, DECEASED

Creditors, next of kin and others having claims in respect of the estate of the deceased who died on 16 July 1980 are required by the Executors of the deceased's Will Miervaldis Berzins of 1344 Gregory Street Ballarat Maintenance Electrician and Arnold Kencis of 10 Moola Street Ballarat Motor Mechanic to send particulars to them care of Pirie & Sutton Solicitors of 17 Doveton Street North, Ballarat by 8 December 1980 after which date they will distribute the deceased's assets having regard only to claims of which they then have notice.

Dated 1 October 1980

PIRIE & SUTTON, solicitors, 17 Doveton Street North, Ballarat 10067

**WILLIAM BRUCE TURNER**, late of 207 Forest Street, Bendigo, butcher, DECEASED

Creditors, next of kin and others having claims in respect of the estate of the deceased who died on 18 June 1980 are required by the personal representative Sandhurst and Northern District Trustees and Executors Agency Limited of 18 View Street Bendigo to send particulars to it by 23 December 1980 after which date the personal representative may convey or distribute the assets having regard only to the claims of which it then has notice.

**MESSRS BECK SHEAHAN & CO.**, barristers and solicitors, 238A Hargreaves Street, Bendigo, 3550 10061

**PETER HOWARD CONNELL**, late of 8 Mardan Street, East Newborough

Creditors, next of kin and others having claims in respect of the estate of the deceased (who died on 29 February 1980) are required by the Administratrix Belinda Jane Sincich of Flat 2 1A Mena Street Moe to send particulars of their claims to her care of her solicitors Littleton Hackford & Malkin of 38 Buckley Street Morwell by 1 December 1980 after which date she will convey or distribute the assets having regard only to the claims of which she then has notice.

**LITTLETON HACKFORD & MALKIN**, solicitors, of Morwell 10069

Creditors, next of kin and others having claims in respect of the Estate of John Douglas Dalgliesh formerly of 1 David Street, Ringwood but late of "Glengarry", 10 Hampden Street, Armadale in the State of Victoria, Retired Engineering Surveyor, deceased who died on 21 June 1980 are to send particulars of their claims to The Trustees, Executors and Agency Company Limited of 401 Collins Street, Melbourne in the said State by 1 December 1980 after which date it will distribute the assets having regard only to the claims of which it then has notice.

**FRENKEL, BERKOVITCH, KEFFORD & NEW**, solicitors, of 114 William Street, Melbourne. 10070

**ANTONIUS JOHANNES ALPHONSUS VAN DEN BERG**, late of 36 Whitewood Street, Frankston, retired, DECEASED

Creditors, next of kin and others having claims in respect of the estate of the deceased, who died on 8 May 1980 are required by the Executrices, Johanna Maria Wilhelmina Van Den Berg and Wilhelmina Cornelia Leenstra care of Campbell & Shaw, Solicitors, 30 Chester Street, Oakleigh to send particulars to them by 2 December 1980 after which date the Executrices may convey or distribute the assets, having regard only to the claims of which they then have notice.

Dated 26 September 1980

**CAMPBELL & SHAW**, solicitors, 30 Chester Street, Oakleigh 10034

**RUBY LEVIN**, late of 8/1316 Glenhuntly Road, Carnegie, widow, DECEASED

Creditors, next of kin and others having claims in respect of the estate of the deceased who died on 21 June 1980 are required to send particulars thereof to the Executors of the deceased's Will Aviva Teitel and Charles Bernard Stute care of the undermentioned Solicitors, on or before 3 December 1980 after which date they will distribute the assets in the estate having regard only to the claims of which they have notice.

**J. M. SMITH & EMMERTON**, solicitors, 224 Queen Street, Melbourne 10037

Creditors, next of kin and others having claims against the Estate of Anne Winnifred Anderson (in the Will called Anne Winnifred Anderson), late of Flat 1/9 Napoleon Street, Sans Souci, N.S.W., widow, deceased who died on 25 December 1978, are required to send particulars of their claims to the Public Trustee 168 Exhibition Street Melbourne Vic. 3000 the personal representative on or before 8 December 1980 after which date the Public Trustee may convey or distribute the assets having regard only to the claims of which the Public Trustee then has notice.

Melbourne, 26 September 1980

10039

P. T. SPENCER, Public Trustee

Creditors, next of kin and others having claims in respect of the estate of Sarah Isabel Sampson late of 30 Nurlendi Road, Vermont Widow, deceased, who died on 3 July 1980 are required by the Executor The Union-Fidelity Trustee Company of Australia Limited of 101 Lydiard Street North, Ballarat, Victoria, to send particulars of their claims to the said Trustee Company by 2 December 1980, after which date it will distribute the assets having regard only to the claims of which it then has notice.

**H. L. YUNCKEN & YUNCKEN**, solicitors, 443 Little Collins Street, Melbourne 10038

**ELIZABETH DAISY WALLACE**, formerly of "Ethelmont", Emerald Road, The Patch, but late of Springfield Private Hospital, 162 Albert Avenue, Boronia, in the State of Victoria, spinster, DECEASED

Creditors, next of kin and all other persons having claims against the Estate of the said deceased are required by Ailsa Evelyn Williams of Kerang in the said State Married Woman the Executrix of the Estate of the said deceased to send particulars of such claims to her in care of the undermentioned Solicitors on or before 29 November 1980 after which date she will distribute the assets having regard only to the claims to which she then has notice.

**BASILE & CO.**, barristers and solicitors, 46 Wellington Street, Kerang, Victoria 3579 10055

**MORRY CHOJNA** also known as Moniek Chojna, late of 12/544 Orrong Road, Armadale, in the State of Victoria, company director, DECEASED

Creditors, next of kin and others having claims in respect of the Estate of the abovenamed Deceased, who died on 16 June 1979 are required by Sam Weizman and Harry Chojna, care of Cash and Stone, Solicitors, 294 High Street, Preston, Victoria, to send particulars of their claims to them by 3 December 1980 after which date they may distribute the assets having regard only to the claims of which they then have notice.

**CASH & STONE**, solicitors, 294 High Street, Preston, Victoria, 3072 10056

**CLARICE CHANDLER**, late of 38 Wattle Street, Bendigo, in the State of Victoria, widow, DECEASED

Creditors, next of kin and others having claims against the Estate of the abovenamed deceased who died on 11 March 1980 are required to send particulars thereof to National Trustees Executors and Agency Company of Australasia Limited of 46 Queen Street Bendigo by 1 December 1980 after which date the said Company will distribute the assets of the said deceased having regard only to the claims of which it then has notice.

**WATSON JAMES & ROGERS**, solicitors, 61 Bull Street, Bendigo 10057

Creditors, next of kin and others having claims in respect of the Estate of Gertrude Alice Dowd late of "Halcyon" Maroondah Highway Healesville widow deceased who died on 24 July 1979 are required to send particulars of their claims to the Executors care of the undermentioned Solicitors on or before 10 December 1980 after which date the Executors will distribute the assets of the Estate of the said deceased having regard only to the claims of which they then have notice.

Dated 24 September 1980

**E. L. MORAN & CO.**, solicitors, of 406 Lonsdale Street, Melbourne 10058

**ALEXANDER STANLEY BAILEY**, late of 4 Ferncroft Avenue, East Malvern, in the State of Victoria, retired pharmaceutical chemist, DECEASED

Creditors, next of kin and others having claims in respect of the estate of the abovenamed deceased, who died on 11 May 1980 are required by the Executor The Trustees Executors and Agency Company Limited of 401 Collins Street, Melbourne in the said State to send particulars of their claims to the Executor care of the undermentioned Solicitor by 2 December 1980 after which date the Executor may convey or distribute the assets having regard only to the claims of which they then has notice.

**WINIFRED McCOOK**, solicitor, 173 Whitehorse Road, Ringwood, Victoria 10033

Creditors, next of kin and others having claims against the Estate of Blanche Ellen Clegg Farrell late of 102 Ascot Street South Ballarat Spinster deceased who died on 17 March 1980 are required to send particulars of their claims to the Executor The Union-Fidelity Trustee Company of Australia Limited at its address 101 Lydiard Street North, Ballarat by 2 December 1980 after which date the said Company will distribute the assets having regard only to the claims of which it then has notice.

BAIRD & MCGREGOR, solicitors, Ballarat 10025

KATHLEEN AGNES CURRAN, late of Manangatang, widow, DECEASED (who died on 24 February 1980)

Creditors, next of kin and all persons having claims against the Estate of the deceased are required to send particulars to the Executor The Union-Fidelity Trustee Company of Australia Limited of 101 Lydiard Street North, Ballarat on or before 2 December 1980 after which date it will distribute the assets having regard only to the claims of which it shall then have notice.

HEINZ & GORDON, solicitors, 209 Dana Street, Ballarat 10026

Creditors, next of kin and others having claims in respect of the estate of Lydia Chancellor formerly of 66 Panton Street, Golden Square but late of Bethlehem Home for the Aged, Taylor Street, Golden Square Widow deceased who died on 24 December 1979 are required by National Trustees Executors and Agency Company of Australasia Limited of 46 Queen Street, Bendigo, and Robert Maurice Pethard of 13 Francis Avenue, Vermont Company Director to whom Probate of the Will of the deceased has been granted to send particulars to the said Company by 8 December 1980 after which date the said executors may convey or distribute the assets having regard only to the claims of which they then have notice.

WATSON, JAMES & ROGERS, solicitors, 61 Bull Street, Bendigo 10027

Creditors, next of kin and others having claims in respect of the Estate of Lillias Muriel Hewitt late of Winchelsea widow deceased are required to send particulars of their claims to the executrix Thelma Ethel Parish care of the undermentioned Solicitors on or before 9 December 1980 after which date she will distribute the assets of the estate having regard only to the claims of which she then has notice.

SEWELLS, solicitors, 38 Murray Street, Colac 10028

Creditors, next of kin and others having claims in respect of the Estate of Robert Henry Martin late of 30 Daisy Street, Essendon in the State of Victoria, pensioner, deceased who died on 14 July 1980, are to send particulars of their claims to J. and S. Shatin and Bernstein, solicitors of 224 Queen Street, Melbourne in the said State, the solicitors for the Executor appointed by the Will of the deceased, by 31 December 1980.

J. & S. SHATIN & BERNSTEIN, solicitors, of 224 Queen Street, Melbourne 10029

After the expiration of 14 clear days application will be made to the Supreme Court of Victoria that Letters of Administration of the Estate of Wladyslaw Galars (also known as John Galars) late of 55 Soudan Street, West Coburg in the State of Victoria Chef deceased Intestate be granted to Zofia Galars of 55 Soudan Street, West Coburg in the said State, Waitress, the Widow of the said deceased.

KAHN & CLAHR, solicitors, of 213 Lonsdale Street, Melbourne, Victoria 10030

LOUIS MYLES MEYER, late of 24 Brighton Street, Flemington, retired, DECEASED

Creditors, next of kin and others having claims in respect of the estate of the abovenamed deceased who died on 13 June 1980 are to send particulars of their claims to the Administrator Mr Edward Peter Meyer care of the undermentioned Solicitors by 28 November 1980 after which date the said Administrator will distribute the assets having regard only to the claims of which he then has notice.

O'BRIEN & GALANTE, solicitors, 44 Pascoe Vale Road, Moonee Ponds 10031

CATHERINE DOROTHY McCORMACK, late of 38 Bent Street, Moonee Ponds, spinster, DECEASED

Creditors, next of kin and others having claims in respect of the estate of the abovenamed deceased who died on 16 May 1980 are to send particulars of their claims to the Executor Mr John Holden McCormack care of the undermentioned Solicitors by 28 November 1980 after which date the said Executor will distribute the assets having regard only to the claims of which he then has notice.

O'BRIEN & GALANTE, solicitors, 44 Pascoe Vale Road, Moonee Ponds 10032

Creditors, next of kin and others having claims in respect of the Estate of Marion Ruth Mary Jones late of 47 McCracken Street, Essendon, Spinster deceased who died on 28 July 1980 are to send particulars of their claims to The Union-Fidelity Trustee Company of Australia Limited of 100 Exhibition Street, Melbourne by 2 December 1980 after which date the said Company will distribute the assets having regard to the claims of which it then has notice.

R. WADHAM & DOIG, solicitors of 383 Flinders Lane, Melbourne 10108

Creditors, next of kin and other persons having claims against the Estate of Eugen Singer late of 131 Westbury Street, East St. Kilda, Manager, deceased who died on 26 March 1980 are required to send particulars of their claims to the Executors in care of the undermentioned Solicitors by 5 December 1980 after which date the Executors will distribute the assets having regard only for the claims of which they then had notice.

HERBERT HERZOG, LL.B., solicitor, 364 Lonsdale Street, Melbourne 10109

FLORA SHAW STEWART, late of Lae Papua New Guinea, widow, DECEASED

Creditors, next of kin and others having claims in respect of the estate of the deceased who died on 13 May 1979 are required by Burns Philp Trustee Co. Ltd., 51 Pitt Street, Sydney in the State of New South Wales to send particulars of their claims to the said company by 1 December 1980, after which date it will convey or distribute the assets having regard only to the claims of which the company then has notice.

MCMAHON, FEARNLEY, WINTER & KAYNES, solicitors of 411 Collins Street, Melbourne, 3000 10104

Creditors, next of kin and others having claims in respect of the estate of Matthew Michael Gorman late of 9 Milton Street, Bentleigh, Barrister & Solicitor, deceased who died on 17 October 1979 are required by the Executors Nancy Clare Brown and Terence Owen Gorman to send particulars to the said Executors in c/- their Solicitors, Messrs. Gorman & Storer of 450 Little Collins Street, Melbourne, by 30 November 1980 after which date they will distribute the assets having regard only to the claims of which they then have notice.

GORMAN & STORER, solicitors of 450 Little Collins Street, Melbourne, 3000 10105

Creditors, next of kin and others having claims in respect of the Estate of Phyllis Mary Morton late of 4 Beaconsfield Road, East Hawthorn Home duties deceased who died on 16 July 1980 are to send particulars of their claims to the executor, The Trustees Executors and Agency Company Limited of 401 Collins Street, Melbourne by 23 December 1980 after which date it will distribute the assets having regard only to claims of which it then has notice.

ROBERT KING, solicitor of 974 High Street, Armadale 10106

Creditors, next of kin and others having claims in respect of the Estate of Mabel Catherin Douglas Robinson formerly of 40 Wilgah Street, East St. Kilda but late of 16 The Crescent, Highett Widow deceased who died on 3 August 1980 are to send particulars of their claims to the executor, The Trustees Executors and Agency Company Limited of 401 Collins Street, Melbourne by 23 December 1980 after which date it will distribute the assets having regard only to claims of which it then has notice.

ROBERT KING, solicitor of 974 High Street, Armadale 10107



LEILA JOSEPHINE KIMM, late of 458 Campbell Street, Swan Hill in the State of Victoria, widow, DECEASED

Creditors, next of kin and others having claims in respect of the estate of the deceased (who died on 24 May 1980) are required by the executors George Edward Kimm of Guthrie Street, Quambatook in the said State, Valma Elaine Sankey of Maryborough in the said State and Vincent Norman Kimm of 114 Chapman Street, Swan Hill aforesaid, to send particulars to them care of the undersigned by 3 December 1980 after which date the executors may convey or distribute the assets having regard only to the claims of which they then have notice.

HAYES (ALEC M.) & McINERNEY, solicitors, 148 Campbell Street, Swan Hill 10072

ERICA ELDERSON-SMITH, formerly of 210 Orrong Road, Toorak, but late of Sackville House Private Hospital, 48 Sackville Street, Kew spinster DECEASED

Creditors, next of kin and others having claims against the Estate of the deceased who died on 8 January 1980 are required by the Executor Rodney Disney Davidson of 401 Collins Street, Melbourne Solicitor to send particulars of their claims to the Executor care of the undersigned Solicitors on or before 3 December 1980 after which date he will convey and distribute the assets having regard only to the claims of which he then has notice.

HOME, WILKINSON & LOWRY, solicitors of 401 Collins Street, Melbourne 10110

STANLEY MELBOURNE PETERS, late of Unit 6, 12 Hotham Street, Mont Albert, Victoria, retired, DECEASED

Creditors, next of kin and others having claims in respect of the Estate of the Deceased, who died on 10 May 1980, are required by the Trustees Marie Young of 6 Cummings Street, Burwood, Computer Operator and Judith Thomas of 6 Heathfield Court, Croydon, Cook to send particulars to them by 24 December 1980 after which date the Trustees may convey or distribute the assets, having regard only to the claims of which they then have notice.

LLOYD P. GOODE & CO., barristers and solicitors, 406 Lonsdale Street, Melbourne, Victoria 3000 10016

Creditors, next of kin and others having claims in respect of the Estate of Olive Leah O'Brien late of 17A Tennyson Street, Sandringham, Widow, deceased, who died on 24 January 1980 are requested to send particulars of their claims to Kenneth John Clements and Robin Edward Clements both of 221-229 Glenhuntly Road, Elsternwick, the Executors of the Will of the said deceased in care of the undermentioned firm of Solicitors by 7 December 1980 after which date the Executors will distribute the assets having regard only to the claims of which they have notice.

CLEMENTS, MOTT & BETT, solicitors, 221-229 Glenhuntly Road, Elsternwick 10017

NELLIE MAY ARTER, late of 20 Avondale Street, Hampton, widow, DECEASED

Creditors, next of kin and others having claims in respect of the estate of the deceased (who died on 26 July 1980) are required to send particulars of their claims to National Trustees Executors and Agency Company of Australasia Limited of 95 Queen Street, Melbourne before 3 December 1980 after which date it will distribute the assets having regard only to the claims of which it then has notice.

WALSH JOHNSTON & CO., solicitors, 452 High Street, Northcote 10018

JAMES FREDERICK McMILLAN, late of 4 King Street, Swan Hill, in the State of Victoria, retired, DECEASED

Creditors, next of kin and other persons having claims against the Estate of the said deceased who died on 11 August 1980 are required to send particulars of same to the Executors Charles William McMillan and Norman George McMillan in care of the undersigned on or before 26 November 1980 after which date they will distribute the assets having regard only to the claims of which they have notice.

DWYER & BENNETT, barristers and solicitors, 201 Campbell Street, Swan Hill 10022

WILLIAM GEORGE CARTER, late of 43 Warranilla Avenue, Rosebud, retired, DECEASED

Creditors, next of kin and others having claims in respect of the Estate of the deceased (who died on 6 May 1980) are required by the Union-Fidelity Trustee Company of Australia Limited of 100 Exhibition Street Melbourne, to send particulars of their claims to the said Company by 8 December 1980 after which date it will convey or distribute the assets, having regard only to the claims of which the Company then has notice. 10019

Creditors, next of kin and others having claims in respect of the estate of Ellen Margaret Warner, late of 11 Maryvale Crescent, Morwell, Widow deceased, who died on 21 May 1980 are required to send particulars of their claims to the executor The Union-Fidelity Trustee Company of Australia Limited of 100 Exhibition Street Melbourne by 8 December 1980 after which date it will distribute the assets having regard only to the claims of which it then has notice.

C. H. FORD, LL.B., solicitor, 47-9 Princes Street, Traralgon 10020

EILEEN CONDON, late of 4 Lincoln Street, Warragul, gentlewoman, DECEASED

Creditors, next of kin and others having claims in respect to the estate of the deceased who died on 27 October 1979 are required by the Trustees Bernard Michael Condon and Kevin Thomas Condon to send particulars of their claims to them care of the undersigned Solicitors by 1 December 1980 after which date the Trustees may convey or distribute the assets having regard only to the claims of which they then have notice.

GRAY, FRIEND & LONG, solicitors, Warragul 10021

Creditors, next of kin and others having claims against the estate of Mary Josephine Duffy late of Lisfarron Avenue, Cobram, Spinster, deceased are required to send notice of their claim in care of National Trustees Executors and Agency Company of Australasia Limited of 95 Queen Street, Melbourne prior to 26 November 1980, after which date the company will proceed with the distribution of the estate of the deceased having regard only to the claims of which it has notice.

MESSRS CASSIDY & O'RORKE, solicitors, 22 Main Street, P.O. Box 19, Cobram, Vic. 3644 10023

WILLIAM JAMES DAVIES, late of 380 Shannon Avenue, Newtown, Geelong, in the State of Victoria, shop assistant, DECEASED

Creditors, next of kin and others having claims in respect of the Estate of the abovenamed deceased who died on 12 September 1979 are required by Mary Patricia Mahony of 20 Laura Avenue Belmont in the said State and Margaret Mary Brushfield of 28 Fairbrae Avenue Belmont aforesaid Married Women, the Executrices to whom Probate of the Will of the abovenamed deceased was granted to send particulars to them C/o Messrs Gargan & Roache, Solicitors of 51 Malop Street Geelong in the said State by 12 December 1980 after which date they may convey or distribute the assets having regard only to the claims of which they have then had notice.

Dated 23 September 1980

GARGAN & ROACHE, solicitors, of 51 Malop Street, Geelong 10024

#### Trustee Act 1958 NOTICE TO CLAIMANTS

Pursuant to the Trustee Act 1958, creditors next of kin and all other persons having claims in respect of the estate of any deceased person named below are required to send particulars to the legal personal representative or representatives at the addresses stated, after which date the representatives will distribute the assets, having regard only to the claims of which notice has been received:—

George Alexander McQuade, late of 77 Hobson Street, Newport Retired Boilermaker deceased, who died on 9 August 1980. Claims to the Executors Patricia Margaret Azarnikow and Maureen Philomena Toomey care of the under-mentioned Solicitor by 4 December 1980—JOHN F. CARROLL, LL.B., solicitor, 4 Paisley Street, Footscray 10062

Vincent Keith McGorien, late of 51 Bunbury Street, Newport Pensioner deceased intestate, who died on 21 July 1980. Claims to the Administratrix Delia Mary McGorien care of the under-mentioned Solicitor by 4 December 1980—JOHN F. CARROLL, LL.B., solicitor, 4 Paisley Street, Footscray 10063

In the Supreme Court of the State of Victoria  
SALE BY THE SHERIFF

On Thursday 6 November 1980 at 2.30 p.m. at Bailiffs Office, 2nd Floor, 300 Burwood Road, Hawthorn (unless process be stayed or satisfied).

All the Estate and Interest (if any) of Manolis Miska (shown on Certificate of Title as Manolis Miskas), labourer of 41 Casey Drive, Lalor as joint proprietor with Theodore Miskas, labourer of an estate in fee simple in the land described in Certificate of Title Volume 8871 Folio 848 upon which is erected a brick veneer dwelling known as No. 41 Casey Drive, Lalor.

Registered Mortgage No. G.897440 affects the said estate and interest.

Terms—Cash only

10111 K. R. MARTIN, Sheriff's Officer

In the Supreme Court of the State of Victoria  
SALE BY THE SHERIFF

On Thursday 6 November 1980 at 2.30 p.m. at Bailiffs Office, 2nd Floor, 300 Burwood Road, Hawthorn (unless process be stayed or satisfied).

All the Estate and Interest (if any) of John Smoglian, metal spinner, 18 Spencer Street, Thomastown as proprietor of an estate in fee simple in the land described in Certificate of Title Volume 8499 Folio 299 upon which is erected a brick factory known as No. 18 Spencer Street, Thomastown.

Registered Mortgage Nos. G.452064 and H.566149 affect the said estate and interest.

Terms—Cash only

10112 K. R. MARTIN, Sheriff's Officer

In the Supreme Court of the State of Victoria  
SALE BY THE SHERIFF

On Thursday 13 November 1980 at 2.30 p.m. at Bailiffs Office, 2nd Floor, 300 Burwood Road, Hawthorn (unless process be stayed or satisfied).

All the Estate and Interest (if any) of Stewart Buchanan Naismith, carpenter, of 2/42 Kingsville Street, West Footscray as joint proprietor with Eileen Alice Naismith, married woman of an estate in fee simple in the land described in Certificate of Title Volume 8425 Folio 720 upon which is erected a dwelling house known as No. 16 Rosala Avenue, North Altona.

Registered Mortgage Nos. B.610844 and B.826367 and Caveat Nos. C.83049 and G.775955 and Covenant contained in Transfer 1334248 affect the said estate and interest.

Terms—Cash only

10113 K. R. MARTIN, Sheriff's Officer

In the Supreme Court of the State of Victoria  
SALE BY THE SHERIFF

On Tuesday 11 November 1980 at 11.30 a.m. at the Police Station, Ballarat (unless process be stayed or satisfied).

All the Estate and Interest (if any) of Peter Carrigg (shown on Memorial as Peter Barnard Carigg) Entertainment Tour Co-ordinator, a last registered owner jointly with Jennifer May Carrigg, both of 1129 Eyre Street, Ballarat, in and to the land described in Memorial of Conveyance Book 768 No. 832 except for that land conveyed in Book 747 No. 972. The land is known as 1129 Eyre Street, Ballarat, upon which is erected a dwelling house.

Mortgage to Ballarat Securities Co-Operative P/L., shown in Conveyance Book 768 No. 833 affects the said estate and interest.

Terms—Cash only

10114 S/Sgt. E. G. MACKIE, Sheriff's Officer

In the Supreme Court of the State of Victoria  
SALE BY THE SHERIFF

On Thursday 6 November 1980 at 2.30 p.m. at Bailiffs Office, 2nd Floor, 300 Burwood Road, Hawthorn (unless process be stayed or satisfied).

All the Estate and Interest (if any) of John Camili, builder and carpenter of 107 Kangaroo Road, Oakleigh as proprietor of an estate in fee simple in the land described in Certificate of Title Volume 6591 Folio 146 upon which is erected a weatherboard house known as No. 107 Kangaroo Road, Oakleigh.

Registered Mortgage Nos. H.796074 and H.836844 affect the said estate and interest.

Terms—Cash only

10115 T. M. NICHOLLS, Sheriff's Officer

In the Supreme Court of the State of Victoria  
SALE BY THE SHERIFF

On Thursday 13 November 1980 at 2.30 p.m. at the Bailiff's Office, 2nd Floor, 300 Burwood Road, Hawthorn (unless process be stayed or satisfied).

All the Estate and Interest (if any) of William Leonard Farrow of 12 Eden Court, Ascot Vale, builder, as proprietor of an estate in fee simple in the land described in Certificate of Title Volume 8229 Folio 781 upon which is erected a dwelling and outbuildings known as 12 Eden Court, Ascot Vale.

Registered Mortgage Nos. G.619297 and H.807139, and Caveat G.913300 affect the said estate and interest.

Terms—Cash only

10116 K. R. MARTIN, Sheriff's Officer

In the Supreme Court of the State of Victoria  
SALE BY THE SHERIFF

On Thursday 6 November 1980 at 2.30 p.m. at the Bailiff's Office, 2nd Floor, 300 Burwood Road, Hawthorn (unless process be stayed or satisfied).

All the Estate and Interest (if any) of Emmanuel Attard (shown on Certificate of Title as Emanuel Attard), pressman, of 150 Station Road, Melton South, as joint proprietor with Catherine Maree Attard, home duties, of an estate in fee simple in the land described in Certificate of Title Volume 8429 Folio 151 upon which is erected a house and dwelling known as No. 150 Station Road, Melton South.

Registered Mortgage No. H.711997 and Caveat No. J.108508 affect the said estate and interest.

Terms—Cash only

10117 K. R. MARTIN, Sheriff's Officer

In the Supreme Court of the State of Victoria  
SALE BY THE SHERIFF

On Thursday 13 November 1980 at 2.30 p.m. at the Bailiff's Office, 2nd Floor, 300 Burwood Road, Hawthorn (unless process be stayed or satisfied).

All the Estate and Interest (if any) of Graham Collard, accountant (shown on Certificate of Title as Graham Alexander Collard), of 1 Crowley Court, Oak Park as proprietor of an estate in fee simple in the land described in Certificate of Title Volume 8515 Folio 966 upon which is erected a brick veneer dwelling known as No. 1 Crowley Court, Oak Park.

Registered Mortgage Nos. G.889059 and H. 127467 affect the said estate and interest.

Terms—Cash only

10118 K. R. MARTIN, Sheriff's Officer

In the Supreme Court of the State of Victoria  
SALE BY THE SHERIFF

On Wednesday 12 November 1980 at 10.30 a.m. at Police Station, Mansfield (unless process be stayed or satisfied).

All the Estate and Interest (if any) of Michael James Mason, contractor, and June Audrey Mason, married woman, both of 4 Ryan Street, Mansfield as joint proprietors of an estate in fee simple in the land described

in Certificate of Title Volume 9161 Folio 061 upon which is erected a weatherboard dwelling and garage known as 4 Ryan Street, Mansfield.

Registered Mortgage No. G.734167 and Caveat H.512881 affect the said estate and interest.

Terms—Cash only  
10119

J. GREEN, Deputy Sheriff

**NOTICE OF MAKING OF STATUTORY RULES**

In pursuance of the provisions of the *Subordinate Legislation Act 1962* and the Regulations made thereunder, notice is given of the making of the following Statutory Rules:—

No.	Mines Act 1958	Price
363/1980.	Mines (Mine Managers) (Fees) Regulations 1980	10c
	<i>Second-hand Dealers Act 1958</i>	
364/1980.	Second-hand Dealers (Exemption No. 16) Regulations 1980	10c
	<i>Printers and Newspapers Act 1958</i>	
365/1980.	Printers and Newspapers (Fees) Regulations 1980	10c
	<i>Transfer of Land Act 1958</i>	
366/1980.	Transfer of Land (Fees) Order 1980	30c
	<i>Weights and Measures Act 1958</i>	
367/1980.	Weights and Measures (Amendment No. 12) Regulations 1980	50c
	<i>Mines Act 1958</i>	
368/1980.	Mines (Explosives Fees) Regulations 1980	10c
	<i>Mining Development Act 1958</i>	
369/1980.	Mining Development (Battery Fees) Regulations 1980	10c
	<i>Explosives Act 1960</i>	
370/1980.	Explosives (Fees) Regulations 1980	20c
	<i>Inflammable Liquids Act 1966</i>	
371/1980.	Inflammable Liquids (Fees) Regulations 1980	10c
	<i>Liquefied Gases Act 1968</i>	
372/1980.	Liquefied Gases (Fees) Regulations 1980	10c
	<i>Workers Compensation Act 1958</i>	
373/1980.	Workers Compensation Board Regulations 1980	10c
	<i>Pipelines Act 1967</i>	
374/1980.	Pipelines (Permits) (Fees) Regulations 1980	10c
	<i>Pipelines Act 1967</i>	
375/1980.	Pipelines (Licence Fees) Regulations 1980	10c
	<i>Extractive Industries Act 1966</i>	
376/1980.	Extractive Industries (Fees) Regulations 1980	20c
	<i>Extractive Industries Act 1966</i>	
377/1980.	Extractive Industries (Quarry Manager's Certificate Fee) Regulations 1980	10c
	<i>Mines Act 1958</i>	
378/1980.	Mines (Miner's Right Claim Fees) Regulations 1980	10c
	<i>Mines Act 1958</i>	
379/1980.	Mines (Miner's Right Fee) Regulations 1980	10c

No.	Mines Act 1958	Price
380/1980.	Mines (Search Licence Fees) Regulations 1980	10c
	<i>Mines Act 1958</i>	
381/1980.	Mines (Leasing Fees) Regulations 1980	10c
	<i>Health Act 1958</i>	
382/1980.	Food and Drug Standards (Amendment No. 24) Regulations 1980	10c
	<i>Health Act 1958</i>	
383/1980.	Food and Drug Standards (Amendment No. 25) Regulations 1980	10c
	<i>Public Service Act 1974</i>	
PSD101/1980.	Public Service Amendment Determinations (No. 101) 1980	20c
PSD102/1980.	Public Service Amendment Determinations (No. 102) 1980	10c
PSD103/1980.	Public Service Amendment Determinations (No. 103) 1980	10c
PSD104/1980.	Public Service Amendment Determinations (No. 104) 1980	10c
PSD105/1980.	Public Service Amendment Determinations (No. 105) 1980	10c
PSD106/1980.	Public Service Amendment Determinations (No. 106) 1980	10c
PSD107/1980.	Public Service Amendment Determinations (No. 107) 1980	10c
PSD110/1980.	Public Service Amendment Determinations (No. 110) 1980	10c

Copies of these Statutory Rules when printed may be purchased at the Sale of Publications Branch of the Government Printing Office, located at 7A Parliament Place, Melbourne, 3002. If ordered by mail, remittance should be addressed to "The Government Printer, Box 203, P.O., North Melbourne, 3051", and should include 50c delivery and handling fee.

The annual subscription rates for Statutory Rules for the year commencing 1 January 1980, payable in advance, are as follows:—

*Statutory Rules (other than Public Service Determinations), Pamphlet copies only	\$36.00
Public Service Determinations	\$25.00

\* The Bound Volume of Statutory Rules is not included in the subscription rate.

F. D. ATKINSON  
Government Printer

**STATE ACTS, 1977**

Copies of the following Acts of the Parliament of Victoria may be obtained at the Government Printing Office, Sale of Publications Branch, 7A Parliament Place, Melbourne, phone 651 2754 or 651 2759, or from any accredited agent, at the price set opposite to each.

A delivery and handling fee must be added to your remittance when ordering by mail as follows:—

Total Value of Acts Ordered	Delivery and Handling Fee
10c-\$2.00	0.50c
\$2.05-\$5.00	\$1.00
\$5.05-\$20.00	\$1.50
Above \$20.00	\$2.00

Also available are:—

Bound Volumes	.. .. \$18.00
Index to the Bound Volumes	.. .. \$8.00

## STATE ACTS, 1977—continued.

No.	Price
8969. Small Claims Tribunals (Amendment) ..	\$0.10
8970. Local Government (Rate Relief) ..	\$0.10
8971. State Electricity Commission (Financial Accommodation) ..	\$0.10
8972. Geelong (Kardinia Park) Land ..	\$0.10
8973. Revocation and Excision of Crown Reser- vations ..	\$0.30
8974. Agricultural Authorities (Members Insur- ance) ..	\$0.10
8975. Racing (Tabella Totalizators) ..	\$0.30
8976. Fuel Emergency ..	\$0.20
8977. Australia and New Zealand Banking Group ..	\$0.20
8978. Co-operative Housing Societies (Leasehold Securities) ..	\$0.10
8979. Geelong Waterworks and Sewerage (Amendment) ..	\$0.20
8980. Yooralla Society of Victoria ..	\$0.10
8981. Melbourne Underground Rail Loop (Amend- ment) ..	\$0.20
8982. Tattersall Consultations (Gold Lottery Consultations) ..	\$0.10
8983. Public Service (Government Offices) ..	\$0.10
8984. Anglican Church of Australia Constitution (Amendment) ..	\$0.20
8985. Portland Harbor Trust (Financial) ..	\$0.10
8986. Epworth Hospital (Guarantee) ..	\$0.10
8987. Mildura College Lands (Mildura Schools Fund) ..	\$0.10
8988. Lotteries Gaming and Betting (Raffles and Bingo) ..	\$0.40
8989. Racing (Amendment) ..	\$0.10
8990. Land Surveyors (Surveyors Board) ..	\$0.10
8991. Railways (Participation in Pipelines) ..	\$0.10
8992. Melbourne and Metropolitan Tramways (Borrowing Powers) ..	\$0.10
8993. Melbourne Wholesale Fruit and Vegetable Market Trust ..	\$0.80
8994. Geelong Grammar Schools Amalgamations ..	\$0.50
8995. Melton Land ..	\$0.10
8996. Land (Surrender of Lands) ..	\$0.10
8997. Shepparton Abattoirs (Amendment) ..	\$0.10
8998. Magistrates' Courts (Commitment) ..	\$0.10
8999. Melbourne and Geelong Corporations (Regent Theatre Buildings) ..	\$0.10
9000. Dental Technicians (Amendment) ..	\$0.10
9001. Motor Car (Breath Testing Stations) (Amendment) ..	\$0.10
9002. Marriage (Amendment) ..	\$0.10
9003. Public Contracts (Amendment) ..	\$0.10
9004. Victorian Dairy Industry Authority ..	\$0.60
9005. Public Service (Director-General of Agri- culture) ..	\$0.20
9006. Local Authorities Superannuation (Contrib- utions) ..	\$0.20
9007. County Court (Amendment) ..	\$0.10
9008. Bail ..	\$0.60
9009. Supply (1977-78, No. 1) ..	\$0.20
9010. Grain Elevators (Amendment) ..	\$0.30
9011. State Electricity Commission (Newport Power Station) ..	\$0.10
9012. Police Offences (Child Pornography) ..	\$0.10
9013. Milk Board (Milk Vendors) ..	\$0.20
9014. Dandenong Valley Authority (Cardinia Creek) ..	\$0.20
9015. Motor Car (Amendment) ..	\$0.50
9016. State Library and National Museum Build- ings Committee ..	\$0.20
9017. Superannuation Benefits ..	\$0.20
9018. Social Welfare (Administration) ..	\$0.20
9019. Statute Law Revision ..	\$0.70
9020. Emerald Tourist Railway ..	\$0.50
9021. The Uniting Church in Australia ..	\$0.60
9022. Local Government (Amendment) ..	\$0.60
9023. Health Commission ..	\$1.10
9024. Geelong Regional Commission ..	\$0.60
9025. Equal Opportunity ..	\$0.60
9026. Land (Land Surrender) ..	\$0.10
9027. Zoological Parks and Gardens (Borrowing Powers) ..	\$0.10
9028. Essential Services (Right to Work) ..	\$0.10
9029. La Trobe University (Amendment) ..	\$0.10
9030. Melbourne and Metropolitan Board of Works (Borrowing Powers) ..	\$0.10
9031. Victorian Institute of Marine Sciences (Council) ..	\$0.20

## STATE ACTS, 1977—continued.

No.	Price
9032. Committees (Attendance Fees) ..	\$0.10
9033. Public Accounts (Amendment) ..	\$0.10
9034. Epworth Hospital (Guarantee) (Amendment) ..	\$0.10
9035. Oakleigh Lands (Bowling Club Lands) ..	\$0.10
9036. Consumer Affairs (Amendment) ..	\$0.10
9037. Melbourne and Metropolitan Board of Works (Powers) ..	\$0.10
9038. Racing (Fees) ..	\$0.10
9039. Crown Reservations (Revocation and Excision) ..	\$0.20
9040. State Forests Works and Services ..	\$0.10
9041. Administration and Probate (Amendment) ..	\$0.10
9042. Commissioners and Justices ..	\$0.10
9043. Property Law (Deeds) ..	\$0.10
9044. Wills (Interested Witnesses) ..	\$0.20
9045. Taxation Appeals (Fees) ..	\$0.10
9046. Labour and Industry ..	\$0.20
9047. Social Welfare (Homeless Persons) ..	\$0.10
9048. Crimes (Armed Robbery) ..	\$0.10
9049. Cattle Compensation (Amendment) ..	\$0.10
9050. Racing (Mixed Sports Gatherings) ..	\$0.10
9051. Labour and Industry (Industrial Appeals Court) ..	\$0.10
9052. Cemeteries (Amendment) ..	\$0.10
9053. Water Supply Works and Services ..	\$0.40
9054. Appropriation (1977-78, No. 1) ..	\$3.10
9055. Pay-roll Tax ..	\$0.10
9056. Gift Duty (Amendment) ..	\$0.10
9057. Youth, Sport and Recreation (State Recrea- tion Council) ..	\$0.30
9058. Macleod Land ..	\$0.10
9059. Statute Law Revision ..	\$0.20
9060. Superannuation (Amendment) ..	\$0.10
9061. Building Industry Long Service Leave (Amendment) ..	\$0.20
9062. Educational Grants (Continuation) ..	\$0.10
9063. Judges Salaries ..	\$0.10
9064. Transport Works and Services ..	\$0.10
9065. Stamps (Amendment) ..	\$0.10
9066. Police Regulation (Amendment) ..	\$0.10
9067. Marine (Pilots Superannuation) ..	\$0.10
9068. Public Works and Services ..	\$0.20
9069. Hospitals Superannuation (Amendment) ..	\$0.20
9070. Probate Duty ..	\$0.30
9071. Land Tax ..	\$0.20
9072. Rural Finance and Settlement Commission (Amendment) ..	\$0.30
9073. Crimes (Married Persons' Liability) ..	\$0.10
9074. Wycheproof Land ..	\$0.10
9075. Age of Majority ..	\$0.20
9076. Health (Amendment) ..	\$0.30
9077. Constitution ..	\$0.10
9078. Change of Ownership Notices ..	\$0.20
9079. Local Government (Promotion of Decentrali- zation) ..	\$0.10
9080. Litter ..	\$0.10
9081. Transport Regulation (Amendment) ..	\$0.10
9082. Egg Industry Stabilization (Amendment) ..	\$0.20
9083. Victorian Government Travel Authority ..	\$0.40

## STATE ACTS, 1978

Copies of the following Acts of the Parliament of Victoria may be obtained at the Government Printing Office, Sale of Publications Branch, 7A Parliament Place, Melbourne, phone 651 2754 or 651 2759, or from any accredited agent, at the price set opposite to each.

A delivery and handling fee must be added to your remittance when ordering by mail as follows:—

Total Value of Acts Ordered	Delivery and Handling Fee
10c-\$2.00	0.50c
\$2.05-\$5.00	\$1.00
\$5.05-\$20.00	\$1.50
Above \$20.00	\$2.00

Also available are:—

Bound Volumes ..	\$21.00
Index to the Bound Volumes ..	\$9.00

STATE ACTS, 1978—continued.		STATE ACTS, 1978—continued	
No.	Price	No.	Price
9084.	Aerial Spraying Control (Amendment) ..	9155.	Crimes (Hijacking and Other Offences) ..
9085.	Dairy Products (Repeal) ..	9156.	Evidence (Amendment) ..
9086.	Gas and Fuel Corporation (Borrowing Powers Amendment) ..	9157.	Motor Car Traders (Amendment) ..
9087.	Constitution ..	9158.	Bail (Amendment) ..
9088.	Marine (Amendment) ..	9159.	Water Drainage ..
9089.	Architects (Professional Conduct) ..	9160.	Legal Profession Practice (Solicitors' Disciplinary Tribunal) ..
9090.	Victorian Film Corporation (Amendment) ..	9161.	Chiropractors and Osteopaths ..
9091.	Melbourne and Metropolitan Board of Works (Borrowing Powers Amendment) ..	9162.	Local Government (Miscellaneous Provisions) ..
9092.	Co-operative Farmers and Graziers District Meat Supply Limited ..	9163.	Hospitals Remuneration Tribunal ..
9093.	Reference Areas ..	9164.	Legal Profession Practice (Amendment) ..
9094.	Molesworth (Land Exchange) ..	9165.	Melbourne and Metropolitan Board of Works (Reconstitution) ..
9095.	Melbourne Wholesale Fruit and Vegetable Market Trust (Licences) ..	9166.	Victoria Conservation Trust (Amendment) ..
9096.	Public Service (Amendment) ..	9167.	Shrine of Remembrance ..
9097.	St. Andrew's Hospital ..	9168.	Pounds (Amendment) ..
9098.	Environment Protection (Amendment) ..	9169.	Queenscliff Land ..
9099.	State Savings Bank (Amendment) ..	9170.	Securities Industry (Amendment) ..
9100.	St. Andrew's Hospital (Guarantee) ..	9171.	Labour and Industry ..
9101.	Education (Amendment) ..	9172.	Dandenong Valley Authority (Recreational Areas and Environmental Areas) ..
9102.	Land (Amendment) ..	9173.	Petroleum (Amendment) ..
9103.	Probate Duty (Application) ..	9174.	Victoria Law Foundation ..
9104.	Supply (1978-79, No. 1) ..	9175.	Mildura Irrigation and Water Trusts (Amendment) ..
9105.	Teaching Service (Appointments) ..	9176.	Judges Salaries ..
9106.	Fisheries (Amendment) ..	9177.	Country Roads (Amendment) ..
9107.	Road Traffic (Amendment) ..	9178.	Port of Melbourne Authority ..
9108.	Co-operative Housing Societies (Amendment) ..	9179.	Melbourne (Snowden Gardens) Land ..
9109.	Granya (Land Exchange) ..	9180.	Surveyors ..
9110.	Sandringham Land ..	9181.	State Forests Works and Services ..
9111.	Vegetation and Vine Diseases (Parasites) ..	9182.	Gas and Fuel Corporation (Municipal Rates) ..
9112.	Melbourne Underground Rail Loop (Borrowing Powers) ..	9183.	Land (Amendment) ..
9113.	Railways (Legal Actions) ..	9184.	Road Traffic ..
9114.	National Parks (Amendment) ..	9185.	Tocumwal Railway Extension (Supplementary Agreement Ratification) ..
9115.	Co-operation (Amendment) ..	9186.	Appropriation (1978-79, No. 1) ..
9116.	Local Government (Promotion of Decentralization) ..	9187.	Lifts and Cranes (Amusement Structures) ..
9117.	Parliamentary Salaries and Superannuation ..	9188.	Health Commission (Amendment) ..
9118.	Country Fire Authority (Borrowing Powers) ..	9189.	Railways ..
9119.	Teaching Service (Migrant Instructors) ..	9190.	Land Tax ..
9120.	Stamps (Amendment) ..	9191.	Country Roads (Borrowing Powers) ..
9121.	State Electricity Commission (Amendment) ..	9192.	Pay-roll Tax ..
9122.	Building Industry Long Service Leave (Amendment) ..	9193.	Melbourne and Metropolitan Tramways (Bundoora Tramway) ..
9123.	Melbourne University (Amendment) ..	9194.	Melbourne Wholesale Fruit and Vegetable Market Trust (Amendment) ..
9124.	Motor Car (Fees and Penalties) ..	9195.	Education (Work Experience for Handicapped Children) ..
9125.	Superannuation (Amendment) ..	9196.	Market Court ..
9126.	State Development Decentralization and Tourism ..	9197.	Consumer Affairs (Amendment) ..
9127.	Melbourne Harbor Trust (Borrowing Powers) ..	9198.	Co-ordination Council (Amendment) ..
9128.	Cluster Titles (Amendment) ..	9199.	Broiler Chicken Industry ..
9129.	Victoria Conservation Trust ..	9200.	Liquor Control ..
9130.	Melbourne and Metropolitan Board of Works (Rate Exemption) ..	9201.	Racing (Amendment) ..
9131.	Geelong Waterworks and Sewerage (Administration and Rates) ..	9202.	Legal Profession Practice (Discipline) ..
9132.	Mildura Irrigation and Water Trust (Merbein) ..	9203.	Ballarat (Childrens Home) ..
9133.	Egg Industry Stabilization (Amendment) ..	9204.	Trustee (Authorized Investments) ..
9134.	Workers Compensation (Special Provisions) ..	9205.	Public Works and Services ..
9135.	Environment Effects ..	9206.	Co-operative Housing Societies (Indemnities) ..
9136.	Workers Compensation (Amendment) ..	9207.	Environment Protection (Noise Control) ..
9137.	Motor Car (Amendment) ..	9208.	Stamps ..
9138.	Town and Country Planning (Amendment) ..	9209.	Water Supply Works and Services ..
9139.	Sewerage Districts (Amendment) ..	9210.	Transport Works and Services ..
9140.	Petroleum Products Subsidy (Amendment) ..	9211.	The Constitution Act Amendment (Conduct of Elections) ..
9141.	Water (Amendment) ..	9212.	Crown Land (Reserves) ..
9142.	Railways (Amendment) ..	9213.	Wine Grape Processing Industry ..
9143.	Local Government (Regional Refuse Disposal) ..	9214.	Summary Offences (Amendment) ..
9144.	Dandenong Valley Authority (Amendment) ..	9215.	Workers Compensation (Share Farmers) ..
9145.	Post-Secondary Education ..	9216.	The Constitution Act Amendment (Conjoint Elections) ..
9146.	Racing (Amendment) ..	9217.	Education (Further Amendment) ..
9147.	Physiotherapists ..	9218.	Country Fire Authority (Borrowing Powers) ..
9148.	Local Government (Municipal Districts) ..	9219.	Public Records (Transfer of Administration) ..
9149.	Ministry of Transport (Passenger Services) ..	9220.	Educational Grants (Continuation) ..
9150.	Geelong Regional Interim Development Order (Validation) ..	9221.	Port of Melbourne (World Trade Centre) ..
9151.	Credit Reporting ..	9222.	Town and Country Planning (Miscellaneous Provisions) ..
9152.	Magistrates' Courts (Amendment) ..	9223.	Members of Parliament (Register of Interests) ..
9153.	Wrongs (Actions for Damages) ..	9224.	Local Government (Rates and Fees) ..
9154.	Magistrates (Interstate Enforcement) ..	9225.	Valuation of Land ..
		9226.	Magistrates' Courts (Stipendiary Magistrates) ..

STATE ACTS, 1978—continued

No.	Price
9227. Charities	\$0.20
9228. Crimes (Criminal Damage)	\$0.30
9229. Crimes (Offences at Sea)	\$0.30
9230. Crimes (Competence and Compellability of Spouse Witnesses)	\$0.10
9231. Domicile	\$0.10
9232. Dog (Amendment)	\$0.20
9233. Dental Technicians (Amendment)	\$0.10
9234. Administrative Law	\$0.10
9235. Melbourne and Metropolitan Board of Works (Miscellaneous Amendments)	\$0.20
9236. Mines (Miscellaneous Provisions)	\$0.40
9237. Wheat Industry Stabilization (Amendment)	\$0.20
9238. Victorian Dairy Industry Authority (Amendment)	\$0.20
9239. Melbourne and Metropolitan Board of Works (Trade Waste)	\$0.10
9240. Trustee Companies (Amendment)	\$0.10
9241. Sewerage Districts (Transfer of Works)	\$0.10
9242. Crimes (Amendment)	\$0.10
9243. Motor Car	\$0.20
9244. Health (Amendment)	\$0.30
9245. Legal Aid Commission	\$0.80
9246. Housing (Amendment)	\$0.80
9247. National Parks	\$0.50
9248. Community Welfare Services	\$0.80
9249. Victorian Brown Coal Council	\$0.20
9250. Police Offences (Offensive Publications)	\$0.20

STATE ACTS, 1979—continued

No.	Price
9275. Co-operation	\$0.40
9276. Cemeteries (Melbourne General Cemetery)	\$0.10
9277. Melbourne and Metropolitan Board of Works (Amendment)	\$0.30
9278. River Improvement (Trusts and Valuations)	\$0.10
9279. Instruments (Writs)	\$0.10
9280. Forests (Reserved Land)	\$0.10
9281. Trinity College	\$0.50
9282. Revocation and Excision of Crown Reservations	\$0.30
9283. Local Government (Amendment)	\$0.50
9284. Tattersall Consultations (Amendment)	\$0.10
9285. Prahran Market	\$0.10
9286. Geelong Regional Commission (Amendment)	\$0.10
9287. Pharmacists (Amendment)	\$0.10
9288. Legal Profession Practice (Amendment)	\$0.10
9289. Barley Marketing (Amendment)	\$0.10
9290. Water Authorities (Constitution and Powers)	\$0.20
9291. Sewerage Authorities (Constitution and Powers)	\$0.30
9292. Wrongs (Defamation)	\$0.10
9293. Judges Salaries	\$0.10
9294. Poisons (Amendment)	\$0.10
9295. Business Franchise (Petroleum Products) (Licence Fees)	\$0.20
9296. State Electricity Commission (Amendment)	\$0.30
9297. Workers Compensation (Miscellaneous Provisions)	\$1.00
9298. Motor Car (Surcharge)	\$0.10
9299. Unclaimed Moneys	\$0.10
9300. Land Tax	\$0.10
9301. Business Franchise (Tobacco)	\$0.10
9302. Public Authorities (Contributions)	\$0.10
9303. Appropriation (1979-80, No. 1)	\$3.50
9304. Gift Duty (Amendment)	\$0.10
9305. Pay-roll Tax	\$0.30
9306. Transport Works and Services	\$0.20
9307. Melbourne and Metropolitan Tramways (Borrowing Powers)	\$0.10
9308. County Court (Jurisdiction)	\$0.10
9309. State Forests Works and Services	\$0.10
9310. Young Men's Christian Association of Ballarat (Guarantee)	\$0.20
9311. Water Supply Works and Services	\$0.40
9312. Trustee Companies (Trustees Executors)	\$0.10
9313. Commercial Goods Vehicles (Aviation Fuel)	\$0.10
9314. Victorian Development Corporation (Powers)	\$0.20
9315. Town and Country Planning (Planning Schemes)	\$1.00
9316. Victorian Government Travel Authority (Reconstitution)	\$0.10
9317. Stamps (Amendment)	\$0.30
9318. Motor Car (Fees)	\$0.30
9319. Racing (Financial Provisions)	\$0.30
9320. Urban Land Authority	\$0.50
9321. Public Works and Services	\$0.30
9322. Second-hand Dealers (Closing Hours)	\$0.10
9323. Crimes (Amendment)	\$0.10
9324. Transfer of Land (Amendment)	\$0.40
9325. Melbourne College of Divinity	\$0.30
9326. Transport Regulation (Car Pools)	\$0.10
9327. Fisheries (Amendment)	\$0.10
9328. Egg Industry Stabilization (Amendment)	\$0.10
9329. Local Authorities Superannuation	\$0.30
9330. Latrobe Valley (Amendment)	\$0.10
9331. Liquor Control (Amendment)	\$0.10
9332. Motor Accidents (Amendment)	\$0.40
9333. Young Farmers' Finance Council	\$0.30
9334. Probate Duty	\$0.20
9335. Railways (Board)	\$0.10
9336. Ministry of Transport (Amendment)	\$0.10
9337. Abattoir and Meat Inspection (Amendment)	\$0.20
9338. Public Service (Amendment)	\$0.20
9339. Trustee Companies (Amendment)	\$0.20
9340. Vermin and Noxious Weeds (Amendment)	\$0.30
9341. Canned Fruits Marketing	\$0.40
9342. Marine (Amendment)	\$0.40
9343. Shire of Omeo (Tourist Gold Mine)	\$0.30
9344. Presbyterian Trusts	\$0.90

STATE ACTS, 1979

Copies of the following Acts of the Parliament of Victoria may be obtained at the Government Printing Office, Sale of Publications Branch, 7A Parliament Place, Melbourne, phone 651 2754 or 651 2759, or from any accredited agent, at the price set opposite to each.

A delivery and handling fee must be added to your remittance when ordering by mail as follows:—

Total Value of Acts Ordered	Delivery and Handling Fee
10c-\$2.00	0.50c
\$2.05-\$5.00	\$1.00
\$5.05-\$20.00	\$1.50
Above \$20.00	\$2.00

Bound Volumes of 1978 State Acts (\$21.00) and the Index to the Bound Volumes (\$9.00) are also available.

No.	Price
9251. Constitution (Governor's Pension)	\$0.10
9252. Joint Select Committee (Road Safety)	\$0.20
9253. Cattle Compensation	\$0.10
9254. Constitution (Local Government)	\$0.30
9255. Gas and Fuel Corporation (Borrowing Powers)	\$0.10
9256. Ombudsman (Co-operation)	\$0.10
9257. Geelong (Haines Homes) Land	\$0.20
9258. Motor Car (Breath Testing Stations) (Amendment)	\$0.10
9259. Geelong Waterworks and Sewerage (Trust)	\$0.30
9260. Bright (Land Exchange)	\$0.20
9261. Supply (1979-80, No. 1)	\$0.30
9262. Money Lenders (Fees)	\$0.10
9263. Exhibition (Amendment)	\$0.30
9264. Health (Cattle)	\$0.10
9265. Victorian Public Offices Corporation (Amendment)	\$0.10
9266. Community Welfare Services (Amendment)	\$0.10
9267. Margarine (Amendment)	\$0.10
9268. Youth, Sport and Recreation (State Youth Council)	\$0.10
9269. Racing (Restricted Trotting Meetings)	\$0.10
9270. State Electricity Commission (Morwell Land Compensation)	\$0.10
9271. Construction Safety	\$1.00
9272. Business Franchise (Petroleum Products)	\$0.40
9273. Albury-Wodonga Agreement (Amendment)	\$0.40
9274. City of Melbourne (Re-subdivision)	\$0.10

## STATE ACTS, 1979—continued.

No.	Price
9345. Railway Construction and Property Board	\$0.90
9346. Motor Car (Insurance by Pensioners)	\$0.10
9347. Town and Country Planning (Amendment of Schemes)	\$0.10
9348. Labour and Industry (Amendment)	\$0.20
9349. Magistrates' Courts (Civil Jurisdiction)	\$0.40
9350. Master Builders' Association of Victoria (Guarantee)	\$0.20
9351. Education (Amendment)	\$0.20
9352. Educational Grants (Continuation)	\$0.10
9353. Wrongs (Assessment of Damages)	\$0.10
9354. Victorian Arts Centre	\$0.40
9355. Building Industry Long Service Leave (Amendment)	\$0.50
9356. Local Government (Land Liable to Flooding)	\$0.30
9357. Parliamentary Committees (Public Accounts and Expenditure Review Committee)	\$0.20
9358. Superannuation (Amendment)	\$0.30
9359. Health (Proprietary Medicines)	\$0.20
9360. Victorian Fishing Industry Council	\$0.30
9361. Grain Handling Improvement Authorities	\$0.30
9362. Wheat Marketing	\$0.80
9363. State Employees Retirement Benefits	\$1.00
9364. Town and Country Planning (General Amendment)	\$1.00
9365. Industrial Relations	\$1.40

## STATE ACTS, 1980

Copies of the following Acts of the Parliament of Victoria may be obtained at the Government Printing Office, Sale of Publications Branch, 7A Parliament Place, Melbourne, phone 651 2754 or 651 2759, or from any accredited agent, at the price set opposite to each.

A delivery and handling fee must be added to your remittance when ordering by mail as follows:

Total Value of Acts Ordered	Delivery and Handling Fee
10c—\$2.00	0.50c
\$2.05—\$5.00	\$1.00
\$5.05—\$20.00	\$1.50
Above \$20.00	\$2.00

Bound Volumes of 1978 State Acts (\$21.00) and the Index to the Bound Volumes (\$9.00) are also available.

No.	Price
9366. Constitutional Powers (Coastal Waters)	20c
9367. Parliamentary Committees (Public Bodies Review)	40c
9368. Agricultural Chemicals	\$0.50
9369. Central Gippsland (Brown Coal Land Compensation)	\$0.20
9370. Motor Car (Payments by Pensioners)	\$0.20
9371. Navigable Waters (Oil Pollution) (Amendment)	\$0.20
9372. Workers Compensation (General Amendment)	\$0.20
9373. Extractive Industries (Amendment)	\$0.30
9374. Health (Special Accommodation Houses)	\$0.20
9375. Cancer (Amendment)	\$0.20
9376. Victorian Film Corporation (Amendment)	\$0.30
9377. Railways (Bridges)	\$0.10
9378. Wangerrip (Land Exchange)	\$0.20
9379. Supply (1980—81, No. 1)	\$0.30
9380. Crown Land (Mineral Springs)	\$0.20
9381. Groundwater (Mineral Water)	\$0.20
9382. Melbourne Underground Rail Loop (Land Development)	\$0.30
9383. Chiropodists (Amendment)	\$0.10
9384. Youth, Sport and Recreation (Guarantees)	\$0.20
9385. Pensioners' Rates Remission	\$0.30
9386. Motor Car Traders (Amendment)	\$0.40
9387. Victorian Solar Energy Council	\$0.30
9388. Racing (Amendment)	\$0.20
9389. Country Fire Authority (Amendment)	\$0.20

## STATE ACTS, 1980—continued

No.	Price
9390. Local Government (Validation)	\$0.10
9391. Professional Boxing Control (Amendment)	\$0.10
9392. Police Regulation (Retired Police Reserve)	\$0.10
9393. Local Authorities Superannuation (Amendment)	\$0.30
9394. Water (Valuation Equalization)	\$0.20
9395. Upper Yarra Valley and Dandenong Ranges Authority (Amendment)	\$0.20
9396. Dog (Amendment)	\$0.20
9397. Hospitals Superannuation (Amendment)	\$0.20
9398. Hospitals and Charities (Appointment of Administrators)	\$0.10
9399. Home Finance (Borrowing Powers)	\$0.20
9400. State Employees Retirement Benefits (Amendment)	\$0.30
9401. Wodonga Area Land Acquisition (Validation)	\$0.30
9402. Local Government (General Amendment)	\$0.40
9403. Motor Registration	\$0.50
9404. Epworth Hospital	\$0.50
9405. Archaeological and Aboriginal Relics Preservation (Amendment)	\$0.20
9406. Geelong Performing Arts Centre Trust	\$0.40
9407. Imperial Law Re-enactment	\$0.30
9408. Constitutional Powers (Request)	\$0.20
9409. Friendly Societies (Benefits)	\$0.10
9410. Magistrates' Courts (Jurisdiction)	\$0.10
9411. Baker Medical Research Institute	\$0.50
9412. Protection of Animals (Amendment)	\$0.30
9413. Stamps (Amendment)	\$0.40
9414. Liquefied Petroleum Gas Subsidy	\$0.30
9415. Revocation and Excision of Crown Reservations	\$0.30
9416. Forests (Amendment)	\$0.20
9417. Forests (Further Amendment)	\$0.20
9418. Transport (Road Funds)	\$0.20
9419. Building Societies (Amendment)	\$0.60
9420. Legal Profession Practice (Leo Cussen Institute)	\$0.10
9421. Instruments (Powers of Attorney)	\$0.30
9422. Melbourne (Yarra Park) Land	\$0.20
9423. Sale of Land (Deposits)	\$0.20
9424. Post-Secondary Education (Amendment)	\$0.60
9425. Town and Country Planning (Amalgamation)	\$0.90
9426. Imperial Acts Application	\$1.00
9427. Statute Law Revision	\$0.80
9428. Estate Agents	\$1.60

## THE "VICTORIA GOVERNMENT GAZETTE"

PUBLICATION—A VICTORIA GOVERNMENT GAZETTE is published every WEDNESDAY EVENING unless advertised otherwise.

SUBSCRIPTIONS—The Subscription, including postage, is \$62 per annum, or \$31 per half year, payable in advance. Subscriptions are required for whole months, but must cover at least a half-year.

PRIVATE ADVERTISEMENTS—Advertisements will be received by the Government Printer not later than the day preceding publication—at ordinary rates at or before ONE p.m. and at double rates between ONE p.m. and HALF PAST THREE p.m. The charge for ADVERTISEMENTS is 78 cents per line single column and \$1.56 per line double column. The charge for a full page is \$118. The title forms one or more lines as a heading. On an average ten words make a line of single column. Every signature must likewise be counted as a line. The final words of a paragraph though only portion of a line, must be counted as one line. Signatures (in particular) and proper names must be written very clearly in the text: ONE SIDE ONLY of each sheet of paper should be written upon.

All documents NOT CLEARLY PREPARED will be returned unpublished. Where brands occur, not provided for by the ordinary letters of the alphabet, a written explanatory description also must be furnished.

PAYMENTS—Unless the advertiser has a Credit Account, all payments are required in advance. Remittances should be made by cheque, postal order or money order, payable to "GOVERNMENT PRINTER".

CORRESPONDENCE—All correspondence should be addressed to "The Victorian Government Printer, P.O. Box 203, North Melbourne, 3051".

AGENTS FOR THE "VICTORIA GOVERNMENT  
GAZETTE"

The following have been appointed agents to receive Advertisements and Subscriptions for the *Victoria Government Gazette*:—

- ARMSTRONG'S AGENCY, 217 Queen Street, Melbourne, Victoria 3000.  
 ARNALL & JACKSON, 390 Barkly Street, Brunswick, Victoria 3056  
 BAIRNSDALE AUTHORIZED NEWSAGENCY, 132 Main Street, Bairnsdale, Victoria 3875.  
 BENALLA AUTHORIZED NEWSAGENCY, 45 Bridge Street, Benalla, Victoria 3672.  
 BLANE'S AUTHORIZED NEWSAGENTS, 162 Murray Street, Colac, Victoria 3250.  
 CARTER, R. G., ADVERTISING SERVICE PTY. LTD., 129 Church Street, Hawthorn, Victoria 3122.  
 CORNELL, R. G., 126 Eighth Street, Mildura.  
 FAROE, S. W. & E. P., 79 Henty Street, Casterton, Victoria 3311.  
 FRANKS, H., & CO., 184 Ryrie Street, Geelong, Victoria 3220.  
 GORDON & GOTCH AUSTRALASIA LTD., 25-37 Huntingdale Road, Burwood, Victoria 3125.  
 HARSTON, PARTRIDGE & CO. PTY. LTD., 455 Little Collins Street, Melbourne, Victoria 3000.  
 KYNETON GUARDIAN PTY. LTD., P.O. Box 18, Kyneton, Victoria 3444.  
 LONSDALE NEWSAGENCY, 250 Lonsdale Street, Dandenong, Victoria 3175.  
 LOVELL'S SHEPPARTON NEWSAGENCY, 246 Wyndham Street, Shepparton, Victoria 3630.  
 THE MERCANTILE EXCHANGE, 50 Queen Street, Melbourne, Victoria 3000.  
 McDONALD'S NEWSAGENCY, 88 Bridge Street, Ballarat, Victoria 3350.  
 MCGILL'S AUTHORIZED NEWSAGENCY, 183-5 Elizabeth Street, Melbourne, Victoria 3000.  
 McNAUGHTON, P. R. & L. A., 112-114 Gray Street, Hamilton, Victoria 3300.  
 POWNEY'S AUTHORIZED NEWSAGENCY, 293 Hargreaves Street, Bendigo, Victoria 3550.  
 PURDIE, J., & CO., 138 Moorabool Street, Geelong, Victoria 3220.  
 SALE AUTHORIZED NEWSAGENCY 292-294 Raymond Street, Sale, Victoria 3850.  
 VERNONS OF RICHMOND, 261 Bridge Road, Richmond, Victoria 3121.  
 VIEW POINT AUTHORIZED NEWSAGENCY, 4 View-Point, Bendigo, Victoria 3550.

PUBLICATION OF OFFICIAL MATTER

Attention is invited to the following procedure in relation to the publication of official matter in the *Government Gazette*:—

Publication will be facilitated by the submission of carbon copies for the use of the *Gazette Officer*.

1. *Matter submitted to the Executive Council*

Matter submitted to the Executive Council which requires gazettal will normally be published in the issue of the following week.

Where urgent gazettal is required, special arrangements should be made with the *Gazette Officer*, Room 15, first floor, Old Treasury Building.

2. *Other matter*

(a) All other matter duly certified by a responsible officer for publication should be lodged with the *Gazette Officer* not later than half-past Nine a.m. on Tuesday.

(b) Lengthy or involved notices should be forwarded several days before publication.

(c) Proofs, which will be supplied only when specifically requested or at the direction of the *Gazette Officer*, should be returned promptly to avoid delay in publication.

(d) No additions or amendments to matters for publication will be accepted by telephone.

CONTENTS

	Page
Acts of Parliament	3203
Acts of Parliament on Sale at the Government Printing Office	3381
Appointments	3347
Auction Sales Act	3337
Cemeteries—Scale of Fees	3344
Contracts	3340
Country Roads Board	3346
Courts	3330
Estates of Deceased Persons	3335
Government Notices	3326
Lands	3358
Notice to Mariners	3331
Notice of Making of Statutory Rules	3381
Orders in Council—	
Acts—Local Government; Water; Sewerage Districts; Gas; Country Roads Board; Superannuation; Crown Land (Reserves); Lands; Royal Commission; Water, Criminal Injuries Compensation; Fruit and Vegetables; Zoological Parks and Gardens.	3349 et seq
Private Advertisements	3360
Proclamations	3323
Resignations	3348
State Rivers and Water Supply Commission	3338
Tenders	3360
Transport Regulation Board—Public Hearings	3333