



Victoria Government Gazette

No. 42—Wednesday, 20 May 1981

PROCLAMATIONS

ACTS OF PARLIAMENT

PROCLAMATION

By His Excellency the Governor of the State of Victoria and its Dependencies in the Commonwealth of Australia, &c., &c., &c.

I, the Governor of the State of Victoria, in the Commonwealth of Australia, do hereby declare that I have this day assented, in Her Majesty's name, to the Bills passed by the Parliament of the said State, the titles whereof are hereunder set forth, together with the short titles, that is to say:

- No. 9570. "An Act to create new National Parks, to amend the *National Parks Act 1975* and the *Mt. Hotham Alpine Resort Act 1972* and for other purposes." (*National Parks (Amendment) Act 1981*.)
- No. 9571. "An Act to amend the *Environment Protection Act 1970*, to repeal the *Clean Air Act 1958* and for other purposes." (*Environment Protection (Clean Air) Act 1981*.)
- No. 9572. "An Act to make Provision for the Operation of the National Companies and Securities Commission in the State." (*National Companies and Securities Commission (State Provisions) Act 1981*.)
- No. 9573. "An Act to amend the *Water Act 1958*, the *Local Government Act 1958*, the *Drainage of Land Act 1975*, the *Dandenong Valley Authority Act 1963*, the *Melbourne and Metropolitan Board of Works Act 1958*, and for other purposes." (*Water Drainage Act 1981*.)

Given under my Hand and the Seal of the State of Victoria aforesaid, at Melbourne, this nineteenth day of May, in the year of our Lord One thousand nine hundred and eighty-one and in the thirtieth year of the reign of Her Majesty Queen Elizabeth II.

(L.S.) HENRY WINNEKE

By His Excellency's Command

R. J. HAMER
Premier

GOD SAVE THE QUEEN!

NOTE—No. 9570. (1) Except as provided in the following sub-sections this Act shall come into operation on the day on which it receives the Royal Assent.

(2) Section 3 (3) shall come into operation on 1 July 1981.

(3) Section 3 (4) and (5) shall come into operation on a day or on the respective days to be fixed by proclamation or successive proclamations.

(4) Section 3 (6) and sections 7 and 13 shall come into operation on 1 October 1981.

(5) Section 3 (7) shall come into operation on 1 July 1982.

(6) Section 3 (8) shall be deemed to have come into operation on 25 April 1980.

No. 9571. Several provisions of this Act shall come into operation on the day or the respective days to be fixed by proclamation or successive proclamations.

No. 9572 shall come into operation on a date to be fixed by proclamation.

No. 9573 shall come into operation on a day to be fixed by proclamation.

ACTS OF PARLIAMENT

PROCLAMATION

By His Excellency the Governor of the State of Victoria and its Dependencies in the Commonwealth of Australia, &c., &c., &c.

I, the Governor of the State of Victoria, in the Commonwealth of Australia, do hereby declare that I have this day assented, in Her Majesty's name, to the Bills passed by the Parliament of the said State, the titles whereof are hereunder set forth, together with the short titles, that is to say:

- No. 9562. "An Act Relating to the Securities Industry in Victoria." (*Securities Industry (Application of Laws) Act 1981*.)
- No. 9563. "An Act relating to the Interpretation of certain Provisions relating to Corporations and the Securities Industry and for certain other matters." (*Companies and Securities (Interpretation and Miscellaneous Provisions) (Application of Laws) Act 1981*.)
- No. 9564. "An Act relating to the Application of Laws to regulate the Acquisition of Shares in Companies incorporated in Victoria and Matters connected therewith, to amend the *Companies Act 1961* and for other purposes." (*Companies (Acquisition of Shares) (Application of Laws) Act 1981*.)
- No. 9565. "An Act to amend the *Industrial Training Act 1975* and for other purposes." (*Industrial Training (Amendment) Act 1981*.)
- No. 9566. "An Act to provide for the reconstitution of the Victorian College of the Arts and for other purposes." (*Victorian College of the Arts Act 1981*.)
- No. 9567. "An Act with respect to the Economic Development of Victoria, to amend the *Decentralized Industry Incentive Payments Act 1972* and for other purposes." (*Economic Development Act 1981*.)
- No. 9568. "An Act to amend the *Health Act 1958* and for other purposes." (*Health (Exemptions) Act 1981*.)
- No. 9569. "An Act to make further provision with respect to the Construction of Wills, to amend the *Wills Act 1958*, and for other purposes." (*Wills Act 1981*.)

Given under my Hand and the Seal of the State of Victoria aforesaid, at Melbourne, this nineteenth day of May, in the year of our Lord One thousand

nine hundred and eighty-one and in the thirtieth year of the reign of Her Majesty Queen Elizabeth II.

(L.S.)

HENRY WINNEKE

By His Excellency's Command

R. J. HAMER
Premier

GOD SAVE THE QUEEN!

NOTE—No. 9562 shall come into operation on a date to be fixed by proclamation.

No. 9563 shall come into operation on the day on which the *National Companies and Securities Commission (State Provisions) Act 1981* come into operation.

No. 9564 shall come into operation on a date to be fixed by proclamation.

No. 9565 shall come into operation on the day on which it receives the Royal Assent. (i.e., 19 May 1981).

No. 9566. Several provisions of this Act shall come into operation on a day or the respective days to be fixed by proclamation or successive proclamations.

No. 9567. Except where otherwise expressly provided this Act shall come into operation on a day to be fixed by proclamation.

Nos. 9568 and 9569 shall come into operation on the day upon which they receive the Royal Assent (i.e., 19 May 1981).

ACTS OF PARLIAMENT

PROCLAMATION

By His Excellency the Governor of the State of Victoria and its Dependencies in the Commonwealth of Australia, &c., &c., &c.

I, the Governor of the State of Victoria, in the Commonwealth of Australia, do hereby declare that I have this day assented, in Her Majesty's name, to the Bills passed by the Parliament of the said State, the titles whereof are hereunder set forth, together with the short titles, that is to say:—

- No. 9555. "An Act to ratify validate approve and otherwise give effect to an Agreement between the Premier for and on behalf of the State of Victoria and Grawin Proprietary Limited with respect to the Development of Land near Portarlinton in the State of Victoria for the purpose of the Establishment of a Tourist Resort, to provide for the Rezoning of the Land in the Tourist Resort Area, to establish a Committee of Management of Crown Lands in the Tourist Resort Area and for other purposes." (*Port Bellarine Tourist Resort Act 1981.*)
- No. 9556. "An Act to amend Part III. and Part IV. of the *Firearms Act 1958.*" (*Firearms (Shooters' Licences) Act 1981.*)
- No. 9557. "An Act to amend the *Motor Boating Act 1961.*" (*Motor Boating (Amendment) Act 1981.*)
- No. 9558. "An Act to amend the *Melbourne and Metropolitan Board of Works Act 1958* and for other purposes." (*Melbourne and Metropolitan Board of Works (Amendment) Act 1981.*)
- No. 9559. "An Act to increase the Borrowing Powers of the Melbourne Underground Rail Loop Authority." (*Melbourne Underground Rail Loop (Borrowing Powers) Act 1981.*)
- No. 9560. "An Act to amend the *Motor Car Act 1958.*" (*Motor Car (Pensioner Concessions) Act 1981.*)
- No. 9561. "An Act to amend the *Labour and Industry Act 1958.*" (*Labour and Industry (Amendment) Act 1981.*)

Given under my Hand and the Seal of the State of Victoria aforesaid, at Melbourne, this nineteenth day of May, in the year of our Lord One thousand

nine hundred and eighty-one, and in the thirtieth year of the reign of Her Majesty Queen Elizabeth II.

(L.S.)

HENRY WINNEKE

By His Excellency's Command

R. J. HAMER
Premier

GOD SAVE THE QUEEN!

NOTE—Nos. 9555, 9556, 9557 and 9558—The several provisions of these Acts shall come into operation on a day or on respective days to be fixed by proclamation or successive proclamations.

No. 9559 shall come into operation on the day upon which it receives the Royal Assent.

No. 9560 shall be deemed to have come into operation on 1 January 1981.

No. 9561—The several provisions of this Act shall come into operation on a day or on the respective days to be fixed by proclamation or successive proclamations.

ACTS OF PARLIAMENT

PROCLAMATION

By His Excellency the Governor of the State of Victoria and its Dependencies in the Commonwealth of Australia, &c., &c., &c.

I, the Governor of the State of Victoria, in the Commonwealth of Australia, do hereby declare that I have this day assented, in Her Majesty's name, to the Bills passed by the Parliament of the said State, the titles whereof are hereunder set forth, together with the short titles, that is to say:—

- No. 9548. "An Act to amend the *Motor Car Act 1958* with respect to the Mass and Dimension Limits of Motor Cars, to amend the *Stamps Act 1958* and for purposes connected therewith." (*Motor Car (Mass and Dimension Limits) Act 1981.*)
- No. 9549. "An Act to revise the Statute Law." (*Statute Law Revision Act 1981.*)
- No. 9550. "An Act to establish a Government Employee Housing Authority, to make provision with respect to Housing Accommodation for Government Employees, to repeal the *Teacher Housing Act 1970*, to amend certain other enactments, and for other purposes." (*Government Employee Housing Authority Act 1981.*)
- No. 9551. "An Act to amend the *Crown Land (Reserves) Act 1978.*" (*Crown Land Reserves (Amendment) Act 1981.*)
- No. 9552. "An Act to amend the *Urban Renewal Act 1970*, the *Housing Act 1958* and the *Local Government Act 1958.*" (*Urban Renewal (Amendment) Act 1981.*)
- No. 9553. "An Act to amend the *Housing Act 1958* and for other purposes." (*Housing (Amendment) Act 1981.*)
- No. 9554. "An Act to consolidate and amend the Law relating to Penalties and Sentences, to amend the *Crimes Act 1958*, the *Magistrates (Summary Proceedings) Act 1975* and the *Community Welfare Services Act 1970* and for other purposes." (*Penalties and Sentences Act 1981.*)

Given under my Hand and the Seal of the State of Victoria aforesaid, at Melbourne, this nineteenth day of May, in the year of our Lord One thousand nine hundred and eighty-one, and in the thirtieth year of the reign of Her Majesty Queen Elizabeth II.

(L.S.)

HENRY WINNEKE

By His Excellency's Command

R. J. HAMER
Premier

GOD SAVE THE QUEEN!

NOTE—No. 9548—The several provisions of this Act shall come into operation on the day or the respective days to be fixed by proclamation or successive proclamations.

No. 9549—Subject to section 2 (2), this Act shall come into operation on the day on which it receives the Royal Assent (i.e.: 19 May 1981).

No. 9550 shall come into operation on a date to be fixed by proclamation.

Nos. 9551, 9552 and 9553 shall come into operation on the day on which they receive the Royal Assent (i.e.: 19 May 1981).

No. 9554—The several provisions of this Act, except section 44, shall come into operation on a day or the respective days to be fixed by proclamation or successive proclamations. Section 44 shall be deemed to have come into operation on 26 September 1980.

Labour and Industry (Amendment) Act 1980

DATE OF COMMENCEMENT OF CERTAIN PROVISIONS

PROCLAMATION

By His Excellency the Governor of the State of Victoria and its Dependencies in the Commonwealth of Australia, &c., &c., &c.

Whereas by an Act of Parliament of the State of Victoria passed in the twenty-ninth year of the reign of Elizabeth the Second, by the Grace of God Queen of Australia and Her other Realms and Territories, Head of the Commonwealth, intituled the *Labour and Industry (Amendment) Act 1980* (No. 9470), it is, amongst other things, enacted that section 2 of the Act shall come into operation on a day to be fixed by proclamation of the Governor in Council published in the *Government Gazette*.

Now therefore I, the Governor of the State of Victoria, in the Commonwealth of Australia, by and with the advice of the Executive Council of the said State, do by this proclamation fix 1 July 1981 as the day upon which the said section 2 shall come into operation.

Given under my Hand and the Seal of the State of Victoria aforesaid, at Melbourne, this twelfth day of May in the year of our Lord One thousand nine hundred and eighty-one, and in the thirtieth year of the reign of Her Majesty Queen Elizabeth II.

(L.S.) HENRY WINNEKE
By His Excellency's Command

J. H. RAMSAY
Minister of Labour and Industry
GOD SAVE THE QUEEN!

PUBLIC HIGHWAYS—SHIRE OF HEALESVILLE

PROCLAMATION

By His Excellency the Governor of the State of Victoria and its Dependencies in the Commonwealth of Australia, &c., &c., &c.

Whereas by the *Local Government Act 1958*, section 519 it is amongst other things enacted that it shall be lawful for the Governor in Council at any time and from time to time upon the request of the council of any municipality by notice in the *Government Gazette* to proclaim any land reserved used or by purchase or exchange acquired for a street road highway thoroughfare bridge square court alley or right-of-way or any street road lane or passage made or laid out or proposed to be made or laid out on any land of which a plan of subdivision delineating that street road lane or passage has been sealed with the seal of the municipality under sub-division (3) of Division 9 of Part XIX. of the *Local Government Act 1958* or a corresponding previous enactment to be a public highway and that such land shall thereupon and thenceforth from the date of such proclamation become and be absolutely dedicated to the public as a public highway within the meaning of any law then or thereafter in force.

And whereas the Council of the Shire of Healesville has requested that the land hereinafter mentioned, being streets, roads, lanes or passages made or laid out or proposed to be made or laid out on land of which a plan of subdivision

delineating such streets, roads, lanes or passages has been sealed with the seal of the municipality under sub-division (3) of Division 9 of Part XIX. of the *Local Government Act 1958*, or a corresponding previous enactment to be so declared to be public highways.

Now therefore, I, the Governor of the State of Victoria in the Commonwealth of Australia, by and with the advice of the Executive Council of the said State, do by this proclamation declare that Fernbank and Dingley Dell Roads, Healesville shown by hatching on the plans hereunder shall be public highways within the meaning of the said Act.

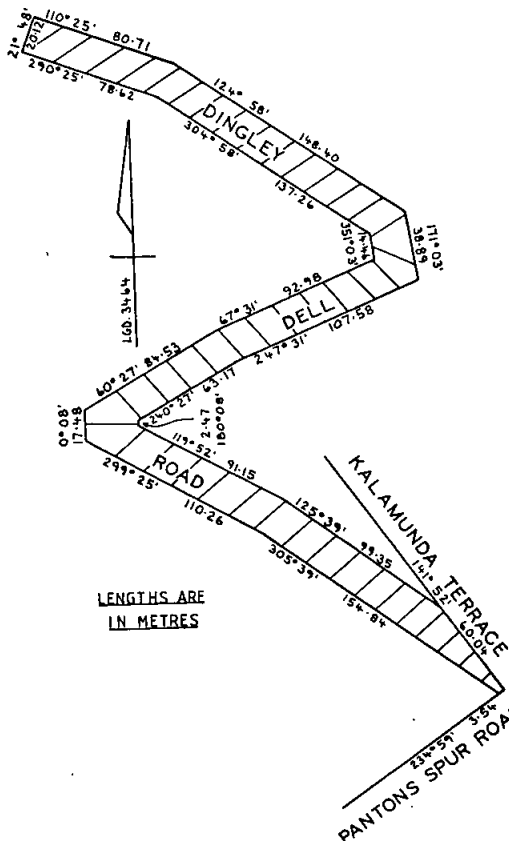
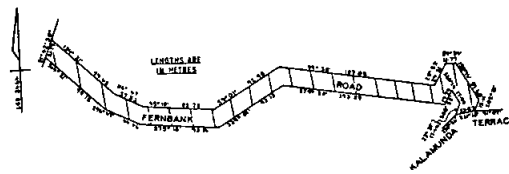

Given under my Hand and the Seal of the State of Victoria aforesaid at Melbourne this twelfth day of May in the year of Our Lord One thousand nine hundred and eighty-one and in the thirtieth year of the reign of Her Majesty Queen Elizabeth II.

(L.S.) HENRY WINNEKE
By His Excellency's Command

D. G. CROZIER
Minister for Local Government
GOD SAVE THE QUEEN!

Motor Boating (Amendment) Act 1981, No. 9557

DATE OF COMING INTO OPERATION

PROCLAMATION

By His Excellency the Governor of the State of Victoria and its Dependencies in the Commonwealth of Australia, &c., &c., &c.

Whereas by an Act of Parliament of the State of Victoria passed in the thirtieth year of the reign of Her Majesty Elizabeth the Second, Queen of Australia, entitled the *Motor Boating (Amendment) Act 1981, No. 9557*, it is amongst other things enacted that the several provisions of this Act shall come into operation on the day or respective days to be fixed by Proclamation or successive Proclamations of the Governor in Council published in the *Government Gazette*.

And whereas it is deemed expedient that a day be fixed on which sections 1, 2 and 3 of the said *Motor Boating (Amendment) Act 1981, No. 9557*, shall come into operation.

Now therefore I, the Governor of the State of Victoria, in the Commonwealth of Australia, by and with the advice of the Executive Council of the said State, do by this my Proclamation fix Wednesday, 20 May 1981, as the day on which sections 1, 2 and 3 of the said *Motor Boating (Amendment) Act 1981, No. 9557*, shall come into operation.

Given under my hand and the Seal of the State of Victoria aforesaid, at Melbourne this nineteenth day of May in the year of Our Lord One thousand nine hundred and eighty-one, and in the thirtieth year of the reign of Her Majesty Elizabeth the Second, Queen of Australia.

(L.S.) HENRY WINNEKE

By His Excellency's Command

L. H. S. THOMPSON
Minister for Police and Emergency Services

GOD SAVE THE QUEEN!

GOVERNMENT NOTICES

Imitation Milk Act 1969

NOTICE

I, Thomas Leslie Austin, Minister of Agriculture, hereby give notice that I have specified "Andronicus Country Maid-Non Dairy Coffee Whitener" as a product exempted from the operation of the *Imitation Milk Act 1969*, on condition that the product is distributed on a retail basis through pharmacies alone and the manufacturer submits quarterly returns of the sales in Victoria to the Department of Agriculture.

The product identification is as follows:

ANDRONICUS COUNTRY MAID-NON DAIRY COFFEE WHITENER

Ingredients	Approximate Percentages
Corn Syrup Solids	53.4%
Vegetable Fat	35.1%
Sodium Caseinate	5.3%
Dipotassium Phosphate	2.0%
Mono and Diglycerides	0.9%
Sodium Silico Aluminate	0.3%
Lecithin	0.05%
Colour	None
Flavour	None

The product is imported by Ray Hubbard Pty. Ltd., 245 Gallaghers Road, Glen Waverley, and is not a Registered Propriety Medicine under the *Health Act 1958*.

T. L. AUSTIN
Minister of Agriculture

Co-operation Act 1958

MONTEREY PRIMARY SCHOOL CO-OPERATIVE LIMITED
MT. ELIZA S.S. CO-OPERATIVE LIMITED
NUNAWADING TENNIS CLUB CO-OPERATIVE LIMITED
PONY CLUB ASSOCIATION CO-OPERATIVE LIMITED
SCORESBY HEIGHTS PRIMARY SCHOOL CO-OPERATIVE LIMITED
SEAFORD-CARRUM HIGH SCHOOL CO-OPERATIVE LIMITED
STELLA MARIS TENNIS CLUB CO-OPERATIVE LIMITED
3RD WEST WAVERLEY BOY SCOUT CO-OPERATIVE LIMITED

NOTICE OF DISSOLUTION OF SOCIETIES

Notice is hereby given that I have this day registered the dissolution of the above-named societies and cancelled their registration under the above-named Act.

Dated at Melbourne, 11 May 1981

J. W. BLACKMAN
Deputy Registrar

Co-operation Act 1958

BURWOOD HEIGHTS STATE SCHOOL CO-OPERATIVE LIMITED
LAKESIDE HIGH SCHOOL CO-OPERATIVE LIMITED
MARCELLIN COLLEGE P. & F. CO-OPERATIVE LIMITED
PADUA COLLEGE HALL CO-OPERATIVE LIMITED
PINES SOCCER CO-OPERATIVE LIMITED

Notice is hereby given in pursuance of section 78 (7) of the *Co-operation Act 1958* and section 308 (2) of the *Companies Act 1961* that, at the expiration of three months from the date hereof, the names of the aforementioned societies will, unless cause is shown to the contrary, be struck off the register and the societies will be dissolved.

Dated 5 May 1981

J. W. BLACKMAN
Deputy Registrar

FARM PRODUCE MERCHANTS AND COMMISSION AGENTS ACT 1965 (No. 7274)

List of names and addresses of licence holders to whom licences have been issued during April 1981. In accordance with the above Act, those issued with a Merchant's or Commission Agent's licence have paid the prescribed contribution to the Farm Produce Merchants and Commission Agents Guarantee Fund. All licences, unless earlier surrendered or cancelled, shall continue in force until 30 June 1981.

D. F. SMITH
Director-General of Agriculture

MERCHANTS

Name	Principal Place of Business
Bendigo Potato Products Pty. Ltd.,	Sullivan Street, Golden Square, 3555
Dobson Cool Store,	Dorset Road, Ferntree Gully, 3156
Madafferi, F., and Co.,	Stores 311-312 Melbourne Wholesale Fruit and Vegetable Market, Footscray, 3011
Southern Produce,	10 Hamlet Street, Cheltenham, 3192
Sunland Distributors,	11 Thompson Street, Ballarat, 3350

COMMISSION AGENT

Neil Forbes International, 120 King Street, Melbourne, 3000

Transport Regulation Act
TRANSPORT REGULATION BOARD

HEARING OF APPLICATIONS

Notice is hereby given that the following applications will be considered by the Transport Regulation Board on 9 June 1981.

RICHARDSON, H. I., Lakes Entrance. Application to license one commercial passenger vehicle with seating capacity for 45 persons to operate a service for the carriage of school children between Lakes Entrance and Bairnsdale Schools under temporary contract to the Education Department.

NOTE—No charter rights are sought in this application.

WOOSTER, R. E., on behalf of Mornington Roller Skating Rink, Mornington. Application to license one commercial passenger vehicle with seating capacity for 37 persons to operate as follows: (i) For the carriage of patrons of the Mornington Roller Skating Rink to and from the Rink in Yuilles Road, Mornington using two routes—(a) Commencing at the Rink in Yuilles Road via Yuilles Road, Mornington—Tyabb Road, Hastings Road, Grants Road, Baxter—Tooradin Road, Sages Road, Moorooduc Road, Bungower Road, Nepean Highway, Mornington—Tyabb Road and Yuilles Road to the rink.

TIME-TABLE

Tuesday nights
Friday nights
Saturday afternoons.

(b) Commencing at the Rink in Yuilles Road, Mornington via Yuilles Road, Mornington—Tyabb Road, Frankston—Flinders Road to Stony Point, returning via Stony Point Road, Frankston—Flinders Road, Watts Road, Gradens Road, Frankston—Flinders Road, Mornington—Tyabb Road and Yuilles Road to the rink.

TIME-TABLE

Thursday nights
Saturday nights
Sunday afternoons.

(ii) For the carriage of members of the Mornington Roller Skating Club to other rinks for the purpose of competing against other clubs.

NOTE—This service is to be provided free of charge.

KINGSTON, F. G., Stawell. Application to license one commercial passenger vehicle with seating capacity for 37 persons to operate in substitution for, but not in addition to existing T.S. licences in the name of the applicant.

NOTE—No charter rights are sought in this application.

ANASTOSOPOULOS, A., Belmont. Application to license one commercial passenger vehicle with seating capacity for seventeen persons to operate, free of charge, for the carriage of employees of the applicant's seafood business between the factory in Curtis Street, Belmont and the Geelong urban area.

PASTOR HENRY MUNRO, on behalf of Melton-Bacchus Marsh Baptist Church, Melton. Application to license one commercial passenger vehicle with seating capacity for 35 persons to operate as follows: (a) For the carriage of members of the Melton-Bacchus Marsh Baptist Church free of charge. (b) For the carriage of school and community groups in the Melton and Bacchus Marsh area on a hire and drive basis. Hiring charge: \$15 per day and 40c per mile.

NOTE—This application is subject to cancellation of licence P.O.405.

READ & BRACK PTY. LTD., Benalla. Application to license one commercial passenger vehicle with seating capacity for 41 persons to operate as a Country Special Service Omnibus from Benalla.

NOTE—This application is subject to cancellation of charter rights of 20-km of Benalla on licence T.S.1257.

WATTS, E. F. & J. M., Grovedale. Application to license one commercial passenger vehicle with seating capacity for 48 persons to operate as follows: (a) Under

the same terms and conditions as licence C.O.291. (b) Under charter conditions from within a 20-km radius of the post office at Geelong.

NOTE—This application is subject to cancellation of licence C.O.291.

WEINSTEIN, M., Templestowe. Application for one Metropolitan taxi licence to be issued subject to the cancellation of Suburban Taxi Licence No. S.T.6509.

KENDERDINE, B. M. (Ms), on behalf of Go Tours, West Melbourne. Application to license an unspecified number of vehicles, with seating capacities for up to 18 persons, to operate for the carriage of passengers on shopping tours within the Greater Metropolitan Area.

NOTE—(i) Tours will be promoted to tourists residing in Hotels in the inner city area and each tour will be in the charge of a trained courier. (ii) The cost of transport is to be included in the all inclusive charge of the tour which will be sold on an individual and/or group basis.

Proposed Daily Schedule—(a) Courier conducts Tourists from respective Hotels to start point of Shopping Tour. (b) Courier assists Tourists with any requests made. Also attends to Lunch and Morning Tea requirements of Tour. (c) Assist any shopkeepers with areas of concern. (d) On conclusion of Tour accompanies Tourists back to respective Hotels.

Application for renewal of licences as shown by the persons listed hereunder to operate under the same terms and conditions.

AJAX NETTLEFOLDS PTY. LTD., Sunshine; S.V.21.

BRASHER, T. E., Shepparton; C.T.557.

ROWE, C. C., St. Kilda; M.T.5148.

THOMAS, D., Mordialloc; S.T.6321.

NORTH SUNSHINE BUS SERVICE PTY. LTD., Sunshine; M.O.307, M.O.326, M.O.339 and M.O.386.

POINT COOK-WERRIBEE PASSENGER SERVICE PTY. LTD., Werribee; M.C.35, M.C.36, M.C.154, M.C.158, M.C.159, M.C.415, M.C.416, M.C.417, M.C.519, M.O.399, M.O.612, M.O.931, M.O.932, M.O.933, M.O.934, M.O.935, M.O.936, M.O.937, M.O.938, M.O.1045, M.O.1060, M.O.1062, M.O.1064 and M.O.1065.

ALDRIDGE, I. C., Torquay; U.T.817.

DEARNESS, S. R., Mordialloc; S.T.5696.

FORD MOTOR CO. OF AUST. PTY. LTD., Norlane; S.V.39.

J. RAY MCDERMOTT AUST. PTY. LTD., Sale; S.V.223.

POLZIN, H. R., North Clayton; S.T.7863.

VOUDIOTIS, A., Forest Hills; M.T.4261.

WATTS, B., Kilsyth; S.T.5839.

Notice of any objections should be forwarded to reach the Secretary of the Board not later than 3 June 1981.

Applicants are advised that it will not be necessary to appear on the hearing date specified, unless advised in writing by the Board.

C. J. V. SMITH, Secretary

Corner Lygon and Princes Streets, Carlton, 3053,
Wednesday, 20 May 1981

State Electricity Commission Act 1958

STATE ELECTRICITY COMMISSION OF VICTORIA

ELECTRICAL APPROVALS BOARD

In accordance with the requirements of the Electrical Approvals Regulations—Proceedings of Electrical Approvals Board, the State Electricity Commission of Victoria hereby gives notice that the following appointments have been made pursuant to the provisions contained in section 51 of the *State Electricity Commission Act 1958*, and the said Regulations, viz:

GORDON EDWARDS as representing the workers in the electrical trade; and
PHILIP JOHN MARKS as representing the interests of the fire underwriters
to be members of the said Board to hold office until 13 June 1984.

Dated 23 April 1981

G. A. MCINTYRE, Secretary

PLACE NAMES COMMITTEE
Survey Co-ordination Act 1958
PROPOSALS TO ASSIGN NAMES

The Place Names Committee hereby gives notice pursuant to the *Survey Co-ordination Act 1958* that it proposes to assign the undermentioned names. Any objection to a proposal must be in writing, stating the reasons therefor, and be lodged with the Committee within two months of publication of this notice.

Ref.	Name	Municipality	Location
M020/1	Deledio Reserve	Shire of Bet Bet	Elgin St, Dunolly, between Lawrence St and Hospital St (Crown reserve Rs.3260)
M165/1	Gavin Park	City of Coburg	As shown on City of Coburg Plan No. 254—Gavin Park
M013/1	Bellbrae West	Shire of Barrabool	The residential area surrounding Portreath, Eaglepoint, Gundrys and Elkinton Rds
M213/1	Guys Hill	Shire of Pakenham	The area comprising the lots on Emerald Rd, Montuna Gve and High St

ASSIGNMENT OF NAMES

The Place Names Committee hereby gives notice that pursuant to the *Survey Co-ordination Act 1958* it has assigned the undermentioned names (in respect of which no objections were received to previously published proposals).

Ref.	Name	Municipality	Location
M212/2	Eumemmerring	City of Berwick	The area bounded by the Eumemmerring Creek, the South Gippsland Fwy and the Princes Hwy
M189/4	Warren Village	City of Mordialloc	The shopping centre at 65-91 Warren Rd, Mordialloc
M212/4	Chalcot Lodge Reserve	City of Berwick	Haverstock Hill Cl, Endeavour Hills
M169/3	Yarraleen Reserve	City of Doncaster and Templestowe	Rocklea Rd, Bulleen
M215/5	Berwick Village	City of Berwick	The Shopping centre at Berwick, as shown on City of Berwick Drawing No. M109
M173/2	G. J. Cruickshank Park	City of Footscray	The park between Somerville Rd and Francis St, Yarraville, along the Stony Creek
M198/8	Wa-wurrong Reserve	City of Ringwood	Felix Cres, Ringwood
M107/3	Selby Park	Shire of Sherbrooke	The area known as Selby Picnic Reserve
M114/1	Patterson Park	Shire of Tambo	In the township of Metung
PN517	Lake Tabberabbera	Shire of Bairnsdale	The lake shown on Plan No. 87997 of the State Rivers and Water Supply Commission
PN517	Tabberabbera Dam	Shire of Bairnsdale	The dam wall for Lake Tabberabbera referred to above.

ALTERATION OF NAME

The Place Names Committee hereby gives notice that pursuant to the *Survey Co-ordination Act 1958* it has altered the undermentioned name in the manner shown (in respect of which no objections were received to the previously published proposal).

Ref: M093/2
Name: Camp Creek
Municipality: Shire of Orbost
Location: As shown on the Cann mapsheet (No. 8722) at grid ref. 850 200
New Name: Barga Creek

P. G. SEWELL, Secretary

Place Names Committee
Department of Crown Lands and Survey
2 Treasury Place
Melbourne, 3002

HEALTH (CONTRACEPTIVES) ACT 1974

Supplement to the Register of Contraceptives published in *Government Gazette* No. 104 of 17 December 1975, in accordance with the provisions of Section 270H (5) of the *Health (Contraceptives) Act 1974*.

Serial No.	Date of Registration	Distinctive Name	Name and Address of Applicant	Remarks	Proprietary Medicine Registration Number
C 096	5.5.81	Triquilar	Schering Pty. Ltd., Wood St, Tempe, N.S.W.	..	19089
C 097	5.5.81	Triquilar E.D.	Schering Pty. Ltd., Wood St, Tempe, N.S.W.	..	19090

Health Commission of Victoria

Dr DAVID FEARON
Acting Assistant Director of Public Health (Maternal and Child Health)

COUNTRY ROADS BOARD

NOTICE OF FIXING NEW ALIGNMENT OF SUNRAYSLIA HIGHWAY IN THE SHIRE OF BIRCHIP

Notice is hereby given that the Country Roads Board under the powers conferred upon it by the *Country Roads Act 1958* (Act No. 6229) has fixed a new alignment for the western side of the Sunrayslia Highway in the Shire of Birchip as shown on Survey Plans numbered 15317 and 15318.

Copies of the said Survey Plans are lodged in the offices of the Country Roads Board, the municipality of the Shire of Birchip, the Registrar of Titles and the Registrar-General respectively, and may be inspected by any person without a fee at any time at which such offices are open for business.

The locality in which the alignment has been fixed is indicated on the plans hereunder—

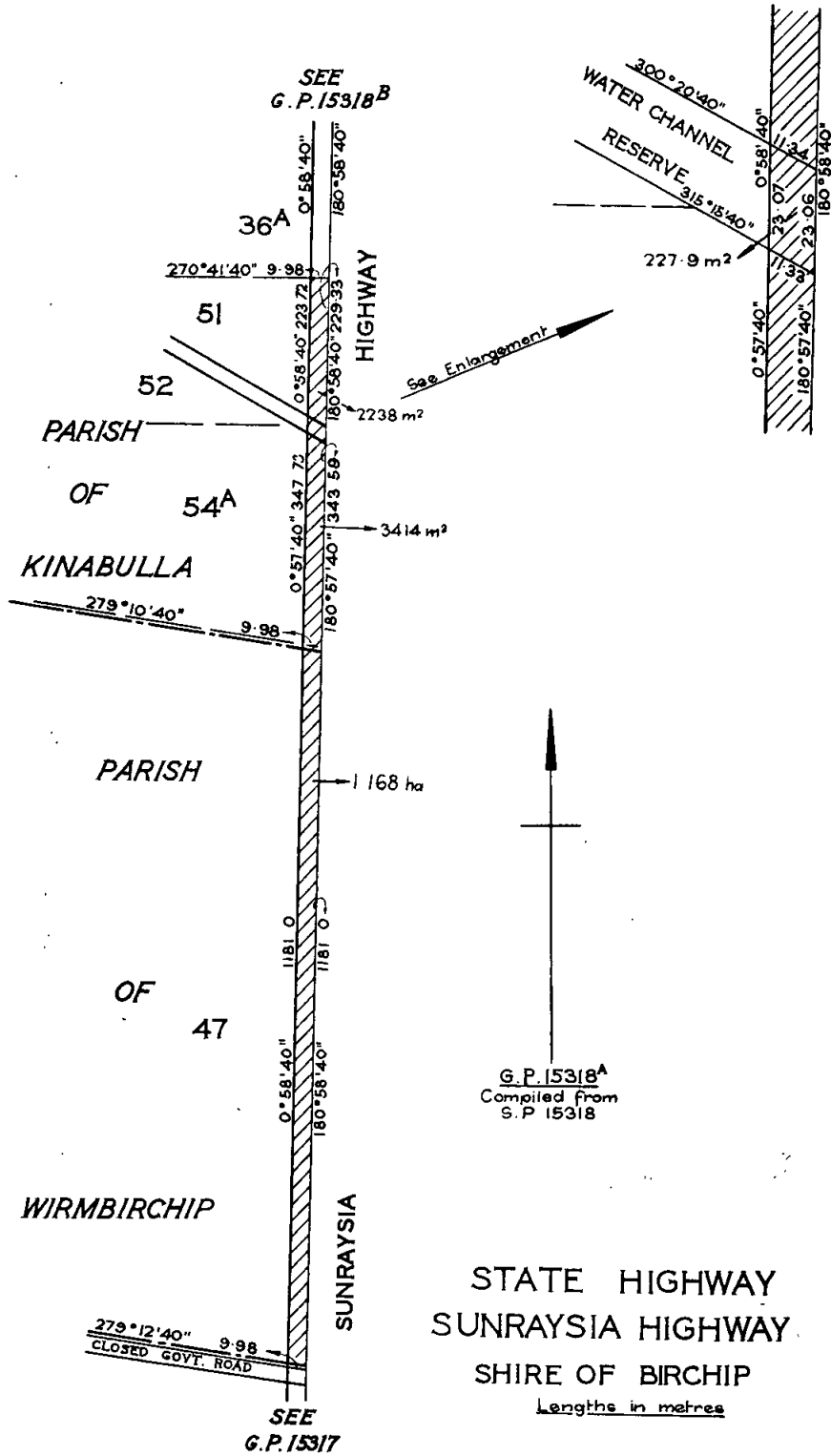

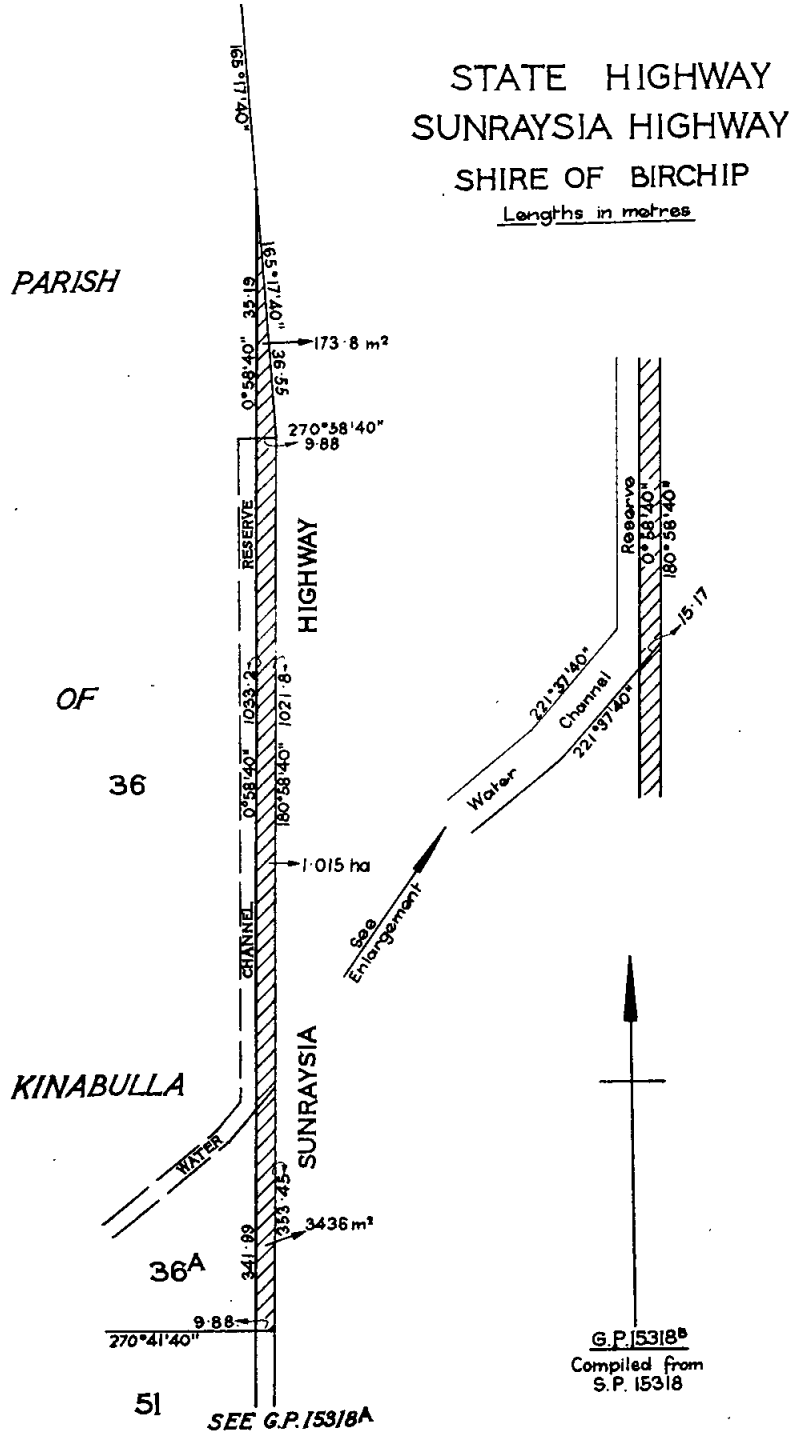

Private Agents Act 1966

NOTICE OF RECEIPT OF APPLICATIONS FOR LICENCES UNDER THE PROVISIONS OF THE PRIVATE AGENTS ACT 1966

The Clerk(s) of the Magistrates' Court(s) as listed hereunder hereby give notice that applications, as under, have been lodged for hearing by the said Court(s) on the date(s) specified.

Any person desiring to object to any of such applications must—

- (a) lodge with the respective Clerk of the Magistrates' Court a notice in the prescribed form of his objection and of the grounds thereof;
- (b) cause a copy of such notice to be served personally or by post upon the applicant at least three days before the hearing of the application; and
- (c) send or deliver—
 - (i) where the objection is not made by the officer in charge of the police district in which the Court is situated—a copy of the notice to such officer; and
 - (ii) where the objection is not made by the Registrar or Deputy Registrar—a copy to the Registrar.

Full Name of Applicant*	Place of Abode of Applicant or Nominee	Name of Firm or Corporation	Address for Registration	Type of Licence	Date of Hearing
MAGISTRATES' COURT, RINGWOOD					
Stonehouse, Kimberley John	6 Eton Square, Wantirna		6 Eton Square, Wantirna	Guard Agent	29.5.81
Dated at Ringwood 6 May 1981 N. T. DAVIDSON, Clerk of the Magistrates' Court					
MAGISTRATES' COURT, SUNBURY					
Foster, Christine May	Lot 55 Washington La, Woodend		Lot 17 Lynne Crt, Gisborne South	Process Server	26.5.81
Dated at Sunbury 8 May 1981 K. ADDICOAT, Clerk of the Magistrates' Court					
MAGISTRATES' COURT, BALLARAT					
Rhodes, Robert John	18 Huntington St, Ballarat	Ray Golging's Ballarat Security Services	423 Cobden St, Ballarat	Watchman	1.6.81
Dated at Ballarat 8 May 1981 A. CROFTS, Clerk of the Magistrates' Court					
MAGISTRATES' COURT, BOX HILL					
Belden, Christopher John	174 Hudson Rd, Spotswood	24 Hour Mercantile Agency	17 Walker St, Doncaster	Commercial Sub-Agents	5.6.81
Dated at Box Hill 8 May 1981 S. G. MACKIE, Clerk of the Magistrates' Court					
MAGISTRATES' COURT, COLLINGWOOD					
Smarrelli, Tony	260 Johnston St, Abbotsford		260 Johnston St, Abbotsford	Individual Guard Agent	10.6.81
Dated at Collingwood 6 May 1981 R. E. LYNEHAM, Clerk of the Magistrates' Court					
MAGISTRATES' COURT, MORWELL					
Witherow, John Edward	Grand Ridge Rd, Boolarra South		Grand Ridge Rd, Boolarra South	Guard Agent	5.6.81
Dated at Morwell 8 May 1981 J. S. HUTCHINS, Clerk of the Magistrates' Court					
MAGISTRATES' COURT, WODONGA					
Daniels, Raymond Guy	277 Tracy St, Lavington, N.S.W.		94 York St, South Melbourne	Watchman	2.6.81
Dated at Wodonga 12 May 1981 P. DODGSON, Clerk of the Magistrates' Court					
MAGISTRATES' COURT, HAMILTON					
Hitchcock, Brian William	18 High St, Hamilton		"Gazette Estate" Penshurst Private Bag 35	Watchman	4.6.81
Dated at Hamilton 11 May 1981 B. F. DOCKING, Clerk of the Magistrates' Court					

* Or in the case of a firm or corporation, of the Nominee

PRIVATE AGENTS—continued

Full Name of Applicant*	Place of Abode of Applicant or Nominee	Name of Firm or Corporation	Address for Registration	Type of Licence	Date of Hearing
MAGISTRATES' COURT, COBURG					
Honey, Francis Edward	1 Heath St, Pascoe Vale		4 Heath St, Pascoe Vale	Process Server	1.6.81
" " "	" "		" "	Commercial Sub Agents	
Dated at Coburg 7 May 1981 P. WENDEN, Clerk of the Magistrates' Court					
MAGISTRATES' COURT, CHELSEA					
Clapperon, Thomas Leonard	63 Rae Ave, Edithvale		4 Dahmen St, Carrum	Watchman	15.6.81
Dated at Chelsea 11 May 1981 H. McINNES, Clerk of the Magistrates' Court					
MAGISTRATES' COURT, PORT MELBOURNE					
Cilia, Francis	31 Eliza St, Keilor Park	Mayne Nickless	94 York St, South Melbourne	Watchman	25.6.81
Dated at Port Melbourne 8 May 1981 S. MERBACH, Clerk of the Magistrates' Court					
MAGISTRATES' COURT, NORTHCOTE					
Samaras, John	756 Heidelberg Rd, Alphington		756 Heidelberg Rd, Alphington	Inquiry Agent	29.5.81
Dated at Northcote 7 May 1981 S. JANSON, Clerk of the Magistrates' Court					
MAGISTRATES' COURT, DANDENONG					
Cartwright, Paul Brian	9 Maxwell St, Dandenong		9 Maxwell St, Dandenong	Inquiry Agent Individual	9.6.81
Dated at Dandenong 11 May 1981 J. T. KNIGHT, Clerk of the Magistrates' Court					
MAGISTRATES' COURT, MELBOURNE					
Doubikin, Raymond Francis	501 Elgar Rd, Box Hill	Transurety Limited	Cnr Arden and Lothian Sts, North Melbourne	Watchman	2.6.81
Sully, Alexander	14 Rhodes St, St Albans	" "	" "	"	"
Watt, Geoffrey Colin	2 Romawi St, Altona	TNT Group 4 Total Security Pty. Ltd.	213 Arden St North Melbourne	"	"
Bell, James Harry John	9 Knox St, East Malvern	Wormald Inter- national Security	340 Abbotsford St, North Melbourne	"	"
Clacherty, Daniel Thomas	RAAF Base Tottenham (Vic)	" "	" "	"	"
Crawshaw, John Stephen	1 Wheeler St, Coldstream	" "	" "	"	"
Dennett, Edward Winston	4/64/66 Francis St, Yarraville	" "	" "	"	"
Ellis, John Arthur Kingsley	Lot 379 Main Rd, Montmorency	" "	" "	"	"
Hall, Marcus James	4 Deakin Ave, Lalor	" "	" "	"	"
Fitzpatrick, Kevin Patrick	11 Murray St, Moonee Ponds	" "	" "	"	"
Gribsby, Kenneth Charles	38 Drinkwater Cres, Sunshine	" "	" "	"	"
Harris, Stephen Leonard	14 Southam St, West Brunswick	" "	" "	"	"
Logan, Trevor William	68/100 Ashworth St, Middle Park	" "	" "	"	"
Rogers, David Christopher	1 Clyde Crt, Oak Park	" "	" "	"	"
Shelley, John Leslie	11 Clarence St, Flemington	" "	" "	"	"
Shortall, Patrick Anthony	854 Nicholson St, North Fitzroy	" "	" "	"	"
Van Dam, Eugene	3/34 Adams St, South Yarra	" "	" "	"	"
Dated at Melbourne 6 May 1981 M. J. QUIRK Clerk of the Magistrates' Court					

* Or in the case of a firm or corporation, of the Nominee

PRIVATE AGENTS—continued

Full Name of Applicant*	Place of Abode of Applicant or Nominee	Name of Firm or Corporation	Address for Registration	Type of Licence	Date of Hearing
MAGISTRATES' COURT, SUNSHINE					
Van Der Veldt, Bernard Albert	46 Hogan St, Deer Park		46 Hogan St, Deer Park	Inquiry Agent	10.6.81
" " " " "	" " "		" " "	Process Server	"
Dated at Sunshine 13 May 1981 D. J. HALPIN, Clerk of the Magistrates' Court					
MAGISTRATES' COURT, CARLTON					
Rahaley, John Lawrence	37 Arcadia Ave, The Basin	Janice Ellen Rose	49 Drummond St, Carlton	Commercial Sub-Agents	2.6.81
Dated at Carlton 8 May 1981 P. H. ARMSTRONG, Clerk of the Magistrates' Court					
MAGISTRATES' COURT, GEELONG					
Gray-Macintosh, Graeme	310 Shannon Ave, Newtown		310 Shannon Ave, Newtown	Inquiry Agent	3.6.81
Dated at Geelong 12 May 1981 J. E. REILLY, Clerk of the Magistrates' Court					
MAGISTRATES' COURT, MOONEE PONDS					
Sheldon, Graham Douglas	20 Sydenham St, Moonee Ponds		20 Sydenham St, Moonee Ponds	Process Server	5.6.81
" " "	" "		" "	Inquiry Server	"
Dated at Moonee Ponds 11 May 1981 J. ISAACS, Clerk of the Magistrates' Court					

* Or in the case of a firm or corporation, of the Nominee

Teaching Service Act 1958

TEACHING SERVICE—SECONDARY SCHOOLS DIVISION
(CLASSIFICATION, SALARIES, AND ALLOWANCES)
REGULATION

AMENDMENT NO. 550 (SEC. C.S. & A. 17)

The Teachers Tribunal, in pursuance of the powers conferred by the Teaching Service Act 1958, hereby amends the Teaching Service—Secondary Schools Division (Classification, Salaries, and Allowances) Regulation as follows:—

- In clause 18 delete the word "disability".
- In Section 6 of Schedule "A", Part II, rescind the expression "Regional relieving assistants.....1369" and substitute therefor the following expression:—

"Metropolitan regional relieving assistants .. 2400
Country regional relieving assistants .. 2650."

(To take effect from and including 17 May 1981)

J. J. KENNEDY, Chairman
L. D. KEEN, Acting Secretary

Office of the Teachers Tribunal
Melbourne, 7 May 1981

Stamps Act 1958

NOTICE UNDER SECTION 40A

Pursuant to section 40A of the Stamps Act 1958 I hereby declare Royal-Globe Life Assurance Company Limited of 440 Collins Street, Melbourne, to be an Authorized Person in relation to Bills of Exchange payable on demand drawn out of Victoria and received for the credit of the company.
5 May 1981

L. H. S. THOMPSON
Treasurer

Education Act 1958

NOTICE OF THE MAKING OF AN ORDER UNDER SECTION 13 (1) OF THE ACT

Pursuant to section 13 of the Education Act 1958 I hereby give notice that an Order of the Governor in Council was made on 3 March 1981 under sub-section (1) of the said Act constituting a Council for the Mt. Evelyn Technical School.

A. J. HUNT
Minister of Education

Education Act 1958

NOTICE OF THE MAKING OF ORDERS UNDER SECTION 13 (4) OF THE ACT

Pursuant to section 13 of the Education Act 1958 I hereby give notice that an Order of the Governor in Council was made on 3 March 1981 under sub-section (4) of the said Act amending certain provisions relating to the constitutions of the Broadmeadows High School and the Rosanna Golf Links Primary School to permit the borrowing the moneys.

A. J. HUNT
Minister of Education

Police Regulation Act 1958, Section 122

SALE OF UNCLAIMED MOTOR CYCLE

An owner is required for a Suzuki 500cc motor cycle, previous registration No. 509 O.M. (Qld.).

The vehicle came into the possession of Police on 25 April 1980, and if not claimed, will be sold by public auction at the Heidelberg Police Station, Jika Street, Heidelberg, on Thursday, 2 July 1981 at 10.30 a.m.

S. I. MILLER
Chief Commissioner

Police Offences Act 1958, No. 6337

DIVISION 1A—STATE CLASSIFICATION OF PUBLICATIONS BOARD

Take note that the State Classification of Publications Board has classified the following publications in accordance with the provisions of section 180H (1) of the Police Offences Act 1958.

Each publication shall be subject to the following restrictions:

- (a) It shall not be offered for sale, sold or delivered to any person under the age of eighteen years.
- (b) It shall not be made available for inspection or perusal by any person under the age of eighteen years.

SCHEDULE OF PUBLICATIONS

Title	Distributor
Best of Penthouse Letters—Collector's Edition No. 1	Gordon & Gotch Ltd.
Chopper—April 1981	Gordon & Gotch Ltd.
Club International Vol. 10 No. 6	Gordon & Gotch Ltd.
Pictorial Guide to Sexual Intercourse, The	Sex Educational Book Co.
Picture Book of Sexual Love, The	Sex Educational Book Co.
Sex to Sixty No. 55	Gordon & Gotch Ltd.

J. SMITH, Secretary
State Classification of Publication Board

Police Offences Act 1958, No. 6337

DIVISION 1A—STATE CLASSIFICATION OF PUBLICATIONS BOARD

Take note that the State Classification of Publications Board has classified the following publications in accordance with the provisions of section 180H (1) of the Police Offences Act 1958.

Each publication shall be subject to the following restrictions:

- (a) It shall not be offered for sale, sold or delivered to any person under the age of eighteen years;
- (b) It shall not be made available for inspection or perusal by any person under the age of eighteen years;
- (c) It shall not be exhibited or displayed in any place to which persons under the age of eighteen years have access or so that it is visible from any such place;

- (d) It shall not be advertised in any manner whatsoever.

SCHEDULE OF PUBLICATIONS

Title	Distributor
Anal Sex No. 37	Claredale Holdings Pty. Ltd.
Best of Action No. 3	View Productions Pty. Ltd.
Bondage & Discipline Quarterly Vol 1 No. 1	View Productions Pty. Ltd.
Dominant Black Bitches Vol. 1 No. 1	View Productions Pty. Ltd.
Fucking Freaks	Claredale Holdings Pty. Ltd.
John Holmes—Deep Throat	View Productions Pty. Ltd.
John Holmes Goes Anal	View Productions Pty. Ltd.
More Than a Mouthful	View Productions Pty. Ltd.
Rodox—Special Magazine No. 8	Claredale Holdings Pty. Ltd.
Wet T-Shirt Vol. 2 No. 2	View Productions Pty. Ltd.

J. SMITH, Secretary
State Classification of Publications Board

Police Offences Act 1958, No. 6337

DIVISION 1A—STATE CLASSIFICATION OF PUBLICATIONS BOARD

Take note that the State Classification of Publications Board has classified the following publications in accordance with the provisions of section 180H (1) of the Police Offences Act 1958.

Each publication shall be subject to the following restrictions:

- (a) It shall not be offered for sale, sold or delivered to any person under the age of eighteen years;
- (b) It shall not be made available for inspection or perusal by any person under the age of eighteen years;
- (c) It shall not be exhibited or displayed in any place to which persons under the age of eighteen years have access or so that it is visible from any such place.

SCHEDULE OF PUBLICATIONS

Title	Distributor
Escort Vol. 1 No. 5	Gordon & Gotch Ltd.
Fling Presents—Every Inch a Lady—Collector's Issue	Gordon & Gotch Ltd.
42+ No. 3	View Productions Pty. Ltd.
Gent—July 1981	Gordon & Gotch Ltd.
Human Digest—July 1981	Gordon & Gotch Ltd.
Secret Joys of Sexual Fulfillment, The	Sex Educational Book Co.

J. SMITH, Secretary
State Classification of Publications Board

Cemeteries Act 1958

SCALE OF FEES OF THE CASTERTON (NEW) PUBLIC CEMETERY

In pursuance of the powers conferred upon them by the Cemeteries Act, the trustees of the Casterton (New) Public Cemetery hereby make the following scale of fees, which shall come into operation upon publication in the Government Gazette, and from and after such publication every scale of fees heretofore made by the said trustees shall be and is hereby rescinded to the extent to which it conflicts with this scale.

Public Graves

	\$
Interment in grave without exclusive right—still born	20.00
Interment in grave without exclusive right—others	40.00

Private Graves

	\$
Land, 2.44 m x 1.22 m (8 feet x 4 feet)	75.00
Land, 3.05 m x 1.22 m (10 feet x 4 feet)	90.00
Sinking grave child under twelve years of age	40.00
Sinking grave 1.83 m deep (6 feet)—others	100.00
Each additional 0.3 m (1 foot)	25.00
Sinking oversize grave (extra)	35.00
Cancellation of order to sink (if commenced)	20.00
Reopening grave (no cover)	60.00
Reopening grave (with cover)	75.00

Miscellaneous Charges

Permission to erect a headstone or monument— 10 per cent of cost with a minimum of \$10.00.	
Exhuming the remains of a body (when authorised)	150.00

J. F. GORMAN, Trustee
W. R. COOPER, Trustee
J. W. ZIPPEL, Trustee

Approved by the Governor in Council, 12 May 1981—
TOM FORRISTAL, Clerk of the Executive Council

Cemeteries Act 1958

SCALE OF FEES OF THE ROSEBERY PUBLIC CEMETERY

In pursuance of the powers conferred upon them by the Cemeteries Act, the trustees of the Rosebery Public Cemetery hereby make the following scale of fees, which shall come into operation upon publication in the *Government Gazette*, and from and after such publication every scale of fees heretofore made by the said trustees shall be and is hereby rescinded to the extent to which it conflicts with this scale.

	\$
Land, 2.44 m x 1.22 m	10.00
Permission to erect a headstone	5.00

I. B. GNIEL, Trustee
A. NAYLOR, Trustee
A. J. CHIVEL, Trustee
R. D. INNES, Trustee

Approved by the Governor in Council, 12 May 1981—
TOM FORRISTAL, Clerk of the Executive Council

Cemeteries Act 1958

SCALE OF FEES OF THE MERINO PUBLIC CEMETERY

In pursuance of the powers conferred upon them by the Cemeteries Act, the trustees of the Merino Public Cemetery hereby make the following scale of fees, which shall come into operation upon publication in the *Government Gazette*, and from and after such publication every scale of fees heretofore made by the said trustees shall be and is hereby rescinded to the extent to which it conflicts with this scale.

Private Graves

	\$
Land, 2.44 m x 1.22 m	32.00
Grave for child under twelve years	16.00
Grave for child under five years and stillborn	12.00
Reopening grave—adult	16.00
Reopening grave—under twelve years	8.00
Reopening grave—under five years and stillborn	4.00
Permission to erect a headstone or monument— 5 per cent of total cost.	

R. A. NORTHCOTT, Trustee
I. NOLTE, Trustee
E. FLYNN, Trustee
D. A. McINTOSH, Trustee

Approved by the Governor in Council, 12 May 1981—
TOM FORRISTAL, Clerk of the Executive Council

Cemeteries Act 1958

SCALE OF FEES OF THE MOONDARRA PUBLIC CEMETERY

In pursuance of the powers conferred upon them by the Cemeteries Act, the trustees of the Moondarra Public Cemetery hereby make the following scale of fees, which shall come into operation upon publication in the *Government Gazette*, and from and after such publication every scale of fees heretofore made by the said trustees shall be and is hereby rescinded to the extent to which it conflicts with this scale.

Private Graves

	\$
Land, 2.44 m x 1.22 m	10.00
Permission to erect a headstone or monument	5.00

H. RAWSON, Trustee
L. BURNS, Trustee
B. THOMAS, Trustee

Approved by the Governor in Council, 12 May 1981—
TOM FORRISTAL, Clerk of the Executive Council

Cemeteries Act 1958

SCALE OF FEES OF THE TYLDEN PUBLIC CEMETERY

In pursuance of the powers conferred upon them by the Cemeteries Act, the trustees of the Tylden Public Cemetery hereby make the following scale of fees, which shall come into operation upon publication in the *Government Gazette*, and from and after such publication every scale of fees heretofore made by the said trustees shall be and is hereby rescinded to the extent to which it conflicts with this scale.

	\$
Sinking grave, 1.83 m deep	80.00
Each additional 0.3 m	15.00
Reopening grave (with cover)	70.00
Reopening grave (without cover)	65.00

A. J. TRANTER, Trustee
W. T. HICKEY, Trustee
W. G. HURLESTONE, Trustee

Approved by the Governor in Council, 12 May 1981—
TOM FORRISTAL, Clerk of the Executive Council

Town and Country Planning Act 1961

MELBOURNE METROPOLITAN PLANNING SCHEME

AMENDMENT No. 113, PART 2B

Notice of Approval

In pursuance of the powers conferred by the *Town and Country Planning Act 1961*, the Governor in Council on 12 May 1981, approved a planning scheme entitled the Melbourne Metropolitan Planning Scheme, Amendment No. 113, Part 2B, in respect of the municipal district of the City of Heidelberg and such planning scheme comes into operation on the date this Notice of Approval is published in the *Government Gazette*.

A copy of the planning scheme as approved may be inspected free of charge, during office hours, at the office of the Department of Planning, 235 Queen Street, Melbourne; at the office of the Melbourne and Metropolitan Board of Works at 625 Little Collins Street, Melbourne, and when available, at the Office of Titles, Melbourne, and at the Central Plan Office of the Department of Crown Lands and Survey, Melbourne.

N. G. HAYNES, Secretary
Department of Planning

Town and Country Planning Act 1961

MELBOURNE METROPOLITAN PLANNING SCHEME

AMENDMENT No. 89

Notice of Approval

In pursuance of the powers conferred by the *Town and Country Planning Act 1961*, the Governor in Council on 12 May 1981, approved a planning scheme entitled the

Melbourne Metropolitan Planning Scheme, Amendment No. 89, in respect of the municipal districts of the Cities of Broadmeadows and Coburg and such planning scheme comes into operation on the date this Notice of Approval is published in the *Government Gazette*.

A copy of the planning scheme as approved may be inspected free of charge, during office hours, at the office of the Department of Planning, 235 Queen Street, Melbourne; at the office of the Melbourne and Metropolitan Board of Works at 625 Little Collins Street, Melbourne, and when available, at the Office of Titles, Melbourne, and at the Central Plan Office of the Department of Crown Lands and Survey, Melbourne.

N. G. HAYNES, Secretary
Department of Planning

Town and Country Planning Act 1961

MELBOURNE METROPOLITAN PLANNING SCHEME

AMENDMENT NO. 88, PART 3

Notice of Approval

In pursuance of the powers conferred by the *Town and Country Planning Act 1961*, the Governor in Council on 12 May 1981, approved a planning scheme entitled the Melbourne Metropolitan Planning Scheme, Amendment No. 88, Part 3 in respect of part of the municipal district of the City of Sunshine and such planning scheme comes into operation on the date this Notice of Approval is published in the *Government Gazette*.

A copy of the planning scheme as approved may be inspected free of charge, during office hours, at the office of the Department of Planning, 235 Queen Street, Melbourne; at the office of the Melbourne and Metropolitan Board of Works at 625 Little Collins Street, Melbourne, and when available, at the Office of Titles, Melbourne, and at the Central Plan Office of the Department of Crown Lands and Survey, Melbourne.

N. G. HAYNES, Secretary
Department of Planning

Town and Country Planning Act 1961

MELBOURNE METROPOLITAN PLANNING SCHEME

NOTICE THAT A PLANNING SCHEME HAS BEEN PREPARED
AND IS AVAILABLE FOR INSPECTION

AMENDING SCHEME NO. 154

Notice is hereby given that the Melbourne and Metropolitan Board of Works in pursuance of its powers under the *Town and Country Planning Act 1961*, has prepared a Planning Scheme which proposes to amend and vary land use zoning within the Planning Area of the Melbourne Metropolitan Planning Scheme which was approved by the Governor in Council on 30 April 1968, and notice thereof published in the *Government Gazette* on 22 May 1968.

A copy of the Amending Scheme has been deposited at the office of the Melbourne and Metropolitan Board of Works, 625 Little Collins Street, Melbourne, at the office of the Town and Country Planning Board, 235 Queen Street, Melbourne, and as to so much of the Amending Scheme as relates to land within the municipal district of any municipality at the office of such municipality, and will be open for inspection during office hours by any person free of charge.

Any persons affected by the Amending Scheme are required to set forth in writing, any submissions they may wish to make with respect to the Amending Scheme, addressed to the Secretary, Melbourne and Metropolitan Board of Works, Box 4342, Melbourne, 3001, by 20 June 1981 and to state whether they wish to be heard in respect of their submissions.

Dated 19 May 1981

O. T. W. COSGRIFF, Secretary
Melbourne and Metropolitan Board of Works, 625 Little Collins Street, Melbourne, 3000

Town and Country Planning Act 1961

MELBOURNE METROPOLITAN PLANNING SCHEME

NOTICE THAT A PLANNING SCHEME HAS BEEN PREPARED
AND IS AVAILABLE FOR INSPECTION

AMENDING SCHEME NO. 166

Notice is hereby given that the Melbourne and Metropolitan Board of Works in pursuance of its powers under the *Town and Country Planning Act 1961*, has prepared a Planning Scheme which makes provision for a major road connection in the City of Heidelberg, from Bell Street to Banksia Street, and certain ancillary modifications to adjacent reservations and zonings.

A copy of the Amending Scheme has been deposited at the office of the Melbourne and Metropolitan Board of Works, 625 Little Collins Street, Melbourne, at the office of the Department of Planning, 235 Queen Street, Melbourne, and at the office of the City of Heidelberg, and will be open for inspection during office hours by any person free of charge.

Any persons affected by the Amending Scheme are required to set forth in writing, any submissions they may wish to make with respect to the Amending Scheme, addressed to the Secretary, Melbourne and Metropolitan Board of Works, Box 4342, Melbourne, 3001, by 20 August 1981 and to state whether they wish to be heard in respect of their submissions.

Dated 19 May 1981

O. T. W. COSGRIFF, Secretary

Melbourne and Metropolitan Board of Works, 625 Little Collins Street, Melbourne, 3000

Melbourne and Metropolitan

BOARD OF WORKS

NOTICE TO OWNERS OF TENEMENTS IN THE UNDERMENTIONED
STREETS AND THE PRIVATE STREETS, LANES, COURTS
OPENING THERETO

The main pipe in the said streets being laid down, the owners of all tenements situated as under are hereby required on or before 22 June 1981 to cause a proper pipe and stop cocks to be laid so as to supply water within such tenements from the main pipe.

Broadmeadows

Evita Terrace, total street from Hillcrest Drive southwards.
Carlinga Court, total street from Trentham Drive south-westwards.

Trentham Drive, from Lenoak Street north-westwards 104 metres.

The Circuit, from Trentham Drive south-westwards 40 metres.

Lenoak Street, from Trentham Drive north-eastwards 128 metres.

Dandenong

Toon Court, total street, from Exner Drive south-westwards.
Matthews Place, total street from Exner Drive north-eastwards and north-westwards.

Exner Drive, from 40 metres northwest of Griffith Street further north-westwards and westwards 198 metres.

Eitham

Buena-Vista Drive, from Reichelt Avenue eastwards 104 metres.

Dalton Street, from 18 metres east of Bible Street further eastwards 260 metres.

Belmont Crescent, from Grand Boulevard westwards and south-westwards 295 metres.

Sackville Street, from 344 metres east of Main Road further eastwards and south-eastwards 226 metres.

Doodson Court, total street from Arthur Street northwards and south-eastwards.

Enfield Street, from Doodson Court northwards and westwards 156 metres.

Knox

Lynton Place, total street from Darryl Street to Ferntree Gully Road.

Darryl Street, total street from Lynton Place eastwards and westwards.

Ferntree Gully Road, from Lynton Place westwards 36 metres.

Cooper Road, from Goulburn Drive eastwards 212 metres.

Lillydale

Hull Road, from Lillydale-Montrose Road south-westwards 64 metres.

Moorabbin

Lauriston Court, from 70 metres south of Keamy Avenue further southwards 90 metres.
Ikara Court, from 70 metres south of Keamy Avenue further southwards 95 metres.
Sundowner Avenue, from 12 metres east of Homeseekers Court further eastwards 61 metres.
Newlands Court, total street from Sundowner Avenue northwards and westwards.

Oakleigh

Bunney Road, from Viney Street eastwards 210 metres.
Darren Court, total street from Bunney Street southwards.
Wayne Court, total street from Bunney Street southwards.

Springvale

Lower Dandenong Road, from Redwood Drive westwards 130 metres.
Redwood Drive, from Lower Dandenong Road northwards and north-westwards 374 metres.
Timberglade Drive, from 18 metres south of Pato Place further south-eastwards and eastwards 107 metres.
Clay Court, total street from Timberglade Drive south-westwards.

Waverley

Atheldene Drive, from 20 metres west of Tiernan Street further south-westwards and westwards 356 metres.
Pentland Court, total street from Atheldene Drive southwards.
Mountleigh Court, total street from Atheldene Drive northwards.

Werribee

Daphne Crescent, total street from Caper Court to Shaws Road.
Blueberry Court, total street from Daphne Crescent southwards.

Whittlesea

Edgars Road, from 68 metres south-east of Collins Street further south-eastwards 60 metres.
Lincoln Drive, from Edgars Road north-eastwards, south-eastwards and eastwards 271 metres.
Plato Court, total street from Lincoln Drive southwards.
Valero Place, total street from Lincoln Drive southwards.
Houston Street, from 76 metres east of Davisson Street further eastwards 73 metres.
Muriel Court, total street from Houston Street northwards and north-westwards.

12 May 1981

O. T. W. COSGRIFF
Secretary

LOCAL GOVERNMENT DEPARTMENT

ORDER CONFIRMED—CITY OF OAKLEIGH

The Minister of the Crown administering the *Local Government Act 1958* on 18 May 1981 confirmed the Order hereinafter referred to in pursuance of section 514 of the said Act namely.

An Order of the Council of the City of Oakleigh made on 23 March 1981 directing the compulsory taking of certain land being Lot 2 on Plan of Subdivision No. 40280 lodged at the Office of Titles for the purpose of car parking.

D. G. CROZIER
Minister for Local Government

Local Government Department
Melbourne (81/1694)

LOCAL GOVERNMENT ACT 1958

Whereas the street, being portion of Government Road situated south of allotment 9 in section 41 in the Township of Ballarat, is within the City of Ballarat and was surveyed and shown as a road in a subdivision by the Crown. And whereas it is alleged that the said street is no longer required for public traffic, and the question whether the said street is or is not required for public traffic has been

referred to the Council of the said City of Ballarat and to the Honourable Minister of the Crown for the time being responsible for administering section 553 (2) of the *Local Government Act 1958*.

Now therefore the said Council and the said Minister as aforesaid having taken the said question into their consideration do under the powers vested in them by this present instrument under the common seal of the said Council and the hand of the said Minister as aforesaid hereby decide that the said street is no longer required for public traffic.

Dated 8 May 1979

The common seal of the Mayor, Councillors and Citizens of the City of Ballarat was hereunto affixed, by Order of the Council—

(SEAL) M. E. J. FOO, Mayor
M. J. BROWN, Councillor
I. C. SMITH, Town Clerk

Given under his hand by the said Minister—

W. V. HOUGHTON
Minister of Lands

Labour and Industry Act 1958

ORDER OF EXEMPTION UNDER SECTION 80A

Whereas pursuant to section 80A of the *Labour and Industry Act 1958* the Council of the City of Warrnambool has applied to the Minister for an Order varying the Order dated 20 December 1979 and published in the *Government Gazette* of 4 January 1980 exempting shopkeepers of shops in its municipal district from being required to close and keep closed their shops in accordance with the provisions of Part VI. of the said Act.

Now therefore I, James Halford Ramsay, Her Majesty's Minister of Labour and Industry in the State of Victoria, do pursuant to the aforesaid section 80A of the *Labour and Industry Act 1958* make this Order, varying the Order dated 20 December 1979, granting exemption to any shopkeeper within the area mentioned in the First Schedule hereto from being required to close and keep closed his shop, at any time when he would but for this Order be required to close and keep closed that shop in accordance with Part VI. of the said Act on any day between the hours of 6 a.m. and 11 p.m. during the periods of the year mentioned in the Second Schedule hereto.

FIRST SCHEDULE—THE AREA

The City of Warrnambool.

SECOND SCHEDULE—THE PERIODS

1. A period of eight consecutive weeks commencing on 15 December each year.
2. The second Monday in March each year and the three days immediately preceding that day.
3. A period of one week commencing on the day immediately preceding Good Friday each year, but excluding Good Friday and excluding Anzac Day if the latter should fall within that period.
4. The day observed as Queen's Birthday each year and the three days immediately preceding that day.
5. Periods of three consecutive weeks commencing on the day after the last day of the first and second school terms as determined from time to time under Regulation XV of the Education Department Regulations 1962.

Dated at Melbourne 1 May 1981

J. H. RAMSAY
Minister of Labour and Industry

INDUSTRIAL AND PROVIDENT SOCIETIES ACT 1958

Notice is hereby given that the following societies were registered under the provisions of the above Act on 12 May 1981:—

A.N.P.P. Limited
Australian Sharetrading and Underwriting Limited

J. F. O'CONNOR
Acting Registrar

EXEMPTION REQUEST No. 3 of 1981

On 12 May 1981 the Equal Opportunity Board considered an application by the Canterbury Family Centre for a temporary exemption under section 34 of the Equal Opportunity Act to enable the Canterbury Family Centre to advertise in certain circumstances for Child Care Workers of a specified sex.

Because of the fact that the Board accepted the submissions of the persons appearing before the Board that children need nurturing from both males and females and because of the fact that a large number of the children at the Canterbury Family Centre are from single parent families the Board hereby grants an exemption from the provision of section 18 (1) (a) and (c) and section 53 of the Equal Opportunity Act in relation to advertising and the offer of employment and engagement of staff as Child Care Workers at the Canterbury Family Centre when the number of Child Care Workers of one sex employed at the Canterbury Family Centre falls below one-third of the total Child Care Workers at the Centre.

This exemption shall remain in effect until 12 May 1983.

JOAN DWYER, Chairman
IAN G. SHARP, Board Member
DON ROSS, Board Member

Forests Act 1958

NOTICE OF INTENTION TO DEDICATE AREAS OF CROWN LAND AS RESERVED FOREST

In accordance with the provisions of section 46 of the Forests Act 1958 notice is hereby given that it is intended to recommend to His Excellency the Governor in Council that pursuant to section 45 of the said Act, the area of Crown land described in the schedule hereunder be dedicated as reserved forest.

SCHEDULE

Seven thousand two hundred hectares more or less of unoccupied Crown land in the Parishes of Boorolite, Changue, Koonika and Wallagoot as shown hatched on plan No. Vic. F.C.11 lodged in the Central Plan Office. (A copy of this plan can be inspected at the Forests Commission Office at Mansfield.)

F. J. GRANTER
Minister of Forests

NOTE—This notice was published first in the *Government Gazette* of 6 May 1981.

CONTRACTS ACCEPTED—(Series 1980-81)

PUBLIC WORKS

His Excellency the Governor of the State of Victoria by and with the advice of the Executive Council thereof, has by Order made on 12 May 1981, approved the acceptance by the Minister of Public Works of the offer of Pioneer Asphalts Pty. Ltd. for asphalt road and basketball courts at Gisborne High School for the sum of Twenty thousand dollars (\$20 000.00) without public tenders being invited—(N.206417"C").

TOM FORRISTAL
Clerk of the Executive Council

At the Executive Council Chamber
Melbourne, 12 May 1981

VICTORIAN RAILWAYS

70. Supply and delivery of 30 No. wagon sets of cast steel freight bogie parts at \$4862.00 per wagon set (Contract 64928)—Bradford Kendall Foundries Pty. Ltd.
71. Construction of Freight Centre pavement at Warracknabeal for the amount of \$26 600.00 (Contract 64909)—S. T. Hamilton Pty. Ltd.

By order of the Victorian Railways Board

I. J. REIHER, Secretary 18.5.81

No. 42—36260/81—2

DEPARTMENT OF MINERALS AND ENERGY

MINING LEASES GRANTED

- No. 336-1; CSR Limited; 220 ha, Parish of Goonegul.
No. 492; Hilary Fynes-Clinton Nevill; 54 ha, Parish of Amherst.
No. 526; Michael Francis Cummins, Marion Therese Cummins, Peter John Cummins, Judith Clair Cummins; 11.7 ha, Parish of Dartagook.

EXPLORATION LICENCE TRANSFERRED

- No. 873; From Aberfoyle Exploration Pty. Ltd. to Dampier Mining Company Limited.

AREA OF EXPLORATION LICENCES RELINQUISHED

- No. 870; Dampier Mining Company Limited; 264 km², comprising Graticular Blocks Nos. 2367, 2368, 2369 and 2441 Hamilton Map Sheet.
No. 871; Dampier Mining Company Limited; 330 km², comprising Graticular Blocks Nos. 2370, 2371, 2442, 2443 and 2444 Hamilton Map Sheet.

EXPLORATION LICENCE EXPIRED

- No. 734; Westralian Sands Limited; 792 km², comprising Graticular Blocks Nos. 3308, 3309, 3310, 3379, 3380, 3381, 3452 and 3453 Adelaide Map Sheet and Nos. 68, 69, 140 and 141 Hamilton Map Sheet. This area will become available again for Exploration Licence on 18 August 1981.

SEARCH LICENCES GRANTED

- No. 1368; Robert William Bennett, Wendy Jean Bennett; 12 ha, Parish of Boort.
No. 1568; Duncan Robert McLean; 16 ha, Parish of Glendhu.
No. 1628; Con Comodromos, Edward Hayes; 40 ha, Parish of Greensborough.
No. 1728; BAR Pty. Ltd.; 40 ha, Parish of Drummond.
No. 1765; Donald Graham Mason; 40 ha, Parish of Flowerdale.
No. 1876; Milton Roy Ellis; 40 ha, Parish of Harrierville.

SEARCH LICENCES EXPIRED

- No. 1392; Michael John Kent; 40 ha, Parish of Goonegerah.
No. 1462; P. J. Fiske, H. Stagg; 40 ha, Parish of Butgulla.

APPLICATION FOR TAILINGS LICENCE REFUSED

- No. 4361; F. Lockyer, M. Rosenow; to remove tailings from "Kangaroo Mine" at Berringa.

TAILINGS LICENCES GRANTED

- No. 4583; David Wright; to remove tailings in State Forest situated at Fosterville.
No. 4618; Shire of Marong; to remove tailings situated within the Water Reserve in section C1, Parish of Tarnagulla.

- No. 4634; Malcolm George Pendlebury; to remove tailings from the "South Goldfields Mullock Dump" situated in the Parish of Mandurang.

- No. 4638; Lenrene Constructions; to remove tailings from the "Moon and Catherine Sand Dumps" situated at Eaglehawk.

TAILINGS LICENCES EXPIRED

No. 4164; The President, Councillors and Ratepayers of the Shire of Maldon; to remove tailings from the "Daydawn, South German Extended and South Parkins" mine dumps situated at Maldon.

No. 4203; The Shire of Buninyong; to remove tailings from the "Leviathan No. 1" situated in the Parish of Yarrowee.

EXTRACTIVE INDUSTRY LEASE GRANTED

No. 109; Warrnambool Limeworks Pty. Ltd.; 6.1 ha, Parish of Wangoom.

LOU LIEBERMAN
Minister for Minerals and Energy

PUBLIC TRUSTEE ACT 1958, SECTION 17

I hereby give notice that on 29 April 1981, the Public Trustee filed elections to administer the following deceased persons' estates in accordance with section 17 of the Public Trustee Act 1958.

ASHLEY, HOWARD ALEX, late of "Strathdon", Unit 32, 17 Jolimont Road, Forest Hill, gentleman, died 14 February 1981.

BONNETT, ARTHUR LEO, late of Room 6, 38 Docker Street, Richmond, pensioner, died 31 January 1981.

KRUGLAYAK, PINYA, late of 9 Fulham Street, South Yarra, fitter, died 26 February 1981.

YOUNG, CHARLES, late of Kew, pensioner, died 1 August 1980.

I hereby give notice that on 7 May 1981, the Public Trustee filed elections to administer the following deceased persons' estates in accordance with section 17 of the Public Trustee Act 1958.

HONEYWELL, CHARLES WING, formerly of 17 Glassford Street, Armadale, but late of Keith House, Armadale, gentleman, died 6 February 1981.

HUDSON, MARGUERITE, late of 128/25 King Street Prahran, widow, died 1 March 1981.

MORRIS, NOELA AILEEN, late of Mont Park, pensioner, died 19 November 1980.

P. T. SPENCER
Public Trustee

168 Exhibition Street, Melbourne, Vic. 3000, 13 May 1981

Creditors, next of kin, and others having claims against the estate of any of the under-mentioned deceased persons are required to send particulars of their claims to the Public Trustee, 168 Exhibition Street, Melbourne, Vic. 3000, the personal representative, on or before 27 July 1981, after which date the Public Trustee may convey or distribute the assets having regard only to the claims of which the Public Trustee then has notice:

ASHLEY, HOWARD ALEX, late of "Strathdon", Unit 32, 17 Jolimont Road, Forest Hill, gentleman, died 14 February 1981.

BANNER, CLIFFORD STANLEY, late of 17 Carinda Road, Canterbury, retired police inspector, died 15 March 1981.

BOLTON, ARTHUR VERE, late of 74 St. Helens Road, East Hawthorn, retired salesman, died 19 December 1980.

BONNETT, ARTHUR LEO, late of Room 6, 38 Docker Street, Richmond, pensioner, died 31 January 1981.

BOYD, DONALD McDONALD MCDUGALL, late of Flat 3, 199 Beach Road, Mordialloc, retired sheet metal worker, died 1 August 1979.

CUMMAUDO, SEBASTIANO, late of 1 Eville Street, South Melbourne, retired labourer, died 11 January 1981.

FARMER, NELLIE KARDINIA SHARLAND, also known as Nellie Kardinia Farmer, formerly of 11 Newhall Avenue, Moonee Ponds, but late of 10 Taldra Street, Box Hill North, widow, died 15 March 1981.

FOLEY, ELIZABETH, formerly of 4 Wave Avenue, Mount Waverley, but late of 5 Remington Drive, Glen Waverley, draftswoman, died 20 February 1981.

GOOD, FLORENCE PRISCILLA, formerly of 291 Buckley Street, Essendon, but late of 14 Comermer Street, Essendon, widow, died 21 March 1981.

GREER, NORMAN McDONALD, formerly of 389 Spencer Street, Melbourne, but late of Bundoora, retired hotel manager, died 25 December 1980.

HARRINGTON, EDITH AGNES, formerly of 5 Maitland Avenue, East Kew, but late of Beechworth, widow, died 15 December 1980.

HAWKINS, THELMA LOLA, formerly of 70 McConnell Street, Kensington, but late of St. Ives Private Nursing Home, 118 Vale Street, East Melbourne, widow, died 19 February 1981.

HONEYWELL, CHARLES WING, formerly of 17 Glassford Street, Armadale, but late of Keith House, Armadale Street, Armadale, gentleman, died 6 February 1981.

HUDSON, MARGUERITE, late of 128/25 King Street Prahran, widow, died 1 March 1981.

JEFFORD, CYRIL JOHN, late of Flat 5, 6 Burnett Street, St. Kilda, rigger, died between 24 and 27 January 1981.

JOHNSTONE, CHARLES JOSEPH, formerly of 8 Rowson Grove, Clayton South, but late of Monuya Nursing Home, 13 Lewis Road, Wantirna South, retired, died 6 September 1979.

KAY, VICTOR, late of 40 Reed Street, Albert Park, dockman, died 5 January 1981.

KENDRICK, WILLIAM MELBOURNE, late of Unit 7, 14 Naples Road, Mentone, retired clerk, died 30 November 1980.

KRUGLAYAK, PINYA, late of 9 Fulham Street, South Yarra, fitter, died 26 February 1981.

MCDIARMID, ELSIE SARAH, formerly of 31 Kellaway Street, Maribyrnong, but late of 29 Sandy Street, Nunawading, home duties, died 4 February 1981.

MCCRAE, CONSTANCE MAIDA, also known as McCrae, Constance, formerly of 40 Wattletree Road, Armadale, but late of St. Heliers Private Nursing Home Pty. Ltd., 2 Canterbury Road, Camberwell, spinster, died 14 January 1981.

MCGOUGH, FRANK HENRY, formerly of 34 Sunburst Avenue, North Balwyn, but late of Lot 48, Monbulk Road, Emerald, Development Training Scheme Officer, died 3 March 1981.

MACAULEY, ROBERT MOFFAT, formerly of Centre Grove, Healesville, but late of 83 Broome Crescent, Wonthaggi, pensioner, died 29 January 1981.

MAPLESTONE, BERYL LOUISE, late of 17 Watson Street; Glen Iris, married woman, died 9 March 1981.

MORRIS, NOELA AILEEN, late of Mont Park, pensioner, died 19 November 1980.

NESTOROS, CHRISTOS, also known as Chris Nestor, formerly of 380 Flinders Street, Melbourne, and 56 Nicholson Street, Fitzroy, but late of 99/103 Vincent Street, Daylesford, milk bar proprietor, died 18 July 1960.

PEARSON, CHARLES AUGUSTUS, late of 37 Vears Road, Burwood, retired manager, died 10 February 1981.

ROBERTSON, JOHN, late of Room T, No. 44, St. Vincents Place, Albert Park, pensioner, died 29 March 1980.

RYAN, MARY, late of "Tandara", 141 Highfield Road, Camberwell, widow, died 27 July 1977.

THURLBY, HARRY BOOLBROOKE, late of Dargo, gentleman, died 11 March 1981.

TSUKASOFF, CLARA, formerly of Flat 9, 311 Carlisle Street, East St. Kilda, but late of Montefiore Home, Hunter's Hill, N.S.W., widow, died 2 February 1981.

WARBURTON, FLORENCE BROWN, formerly of 855 Hampton Street, Brighton, but late of 209 Bay Street, Brighton, widow, died 24 December 1980.

YOUNG, CHARLES, late of Kew, pensioner, died 1 August 1980.

Melbourne, 13 May 1981

P. T. SPENCER
Public Trustee

APPOINTMENTS AND RESIGNATIONS

APPOINTMENTS

His Excellency the Governor of the State of Victoria by and with the advice of the Executive Council thereof has by Orders made on 12 May 1981 been pleased to make the under-mentioned appointments, viz.:

DEPARTMENT OF COMMUNITY WELFARE SERVICES

Honorary Probation Officers

JAMES PATRICK CAHILL, 6 Golden Court, Cobram,
DOROTHY ISABEL DENSON, 10 Wilkur Street, Cobram,
EMMY ELBAUM, 2 Orrong Crescent, Caulfield,
CHRISTOPHER JOHN GRYLLES, 10 Peckover Court, Endeavour Hills,
JOHN CHARLES HOUSTON, 2 Everingham Street, Swan Hill,
HELENE JANICE KENDALL, and
JOHN FRANCIS KENDALL,
P.O. Box 12, Katamatite,
YVONNE JOAN MITCHELL, Station Street, Woorinen South,
ROBERT JOHN MUSSON, 20 Burke Road, Sunbury,
COLIN McLEAN TURTON, 98 Hamel Street, Box Hill South,
AUDREY TOWNSEND, 69 Kennedy Street, Euroa,
to be Honorary Probation Officers for all Adult and Children's Courts in Victoria pursuant to the provisions of section 507 (2) of the *Crimes Act 1958*, and section 9 of the *Children's Court Act 1973*.

MINISTRY FOR CONSERVATION

Members of the Zoological Board of Victoria

ALFRED DUNBAVIN BUTCHER, on the nomination of the Minister for Conservation,
KENNETH JOHN SIMPFENDORFER, being an officer of the Lands Department or the Forests Commission or the State Forests Department,
KENNETH VINCENT FINLAYSON JUBB and
GRAEME BRUCE RYAN,
from a panel of not less than five names (at least two of which are graduates in veterinary science) submitted to the Minister by the Council of the University of Melbourne,
WILLIAM GEORGE BURNS,
JOHN CONNELL, and
JOHN GORDON BATE,

to be Members of the Zoological Board of Victoria during the period 17 May 1981 to 16 May 1985, both dates inclusive pursuant to the *Zoological Parks and Gardens Act 1967*.

LEON RESS,
to be a Member of the Zoological Board of Victoria during the period 17 May 1981 to 16 May 1982, both dates inclusive, pursuant to the *Zoological Parks and Gardens Act 1967*.

Members of the District Advisory Committee, Southern Wimmera Soil Conservation District

GERARD JOSEPH CRANAGE, being a person elected to represent grazing, agricultural and other relevant interests in the District,
RONALD JAMES ELLIOTT, being a person elected to represent grazing, agricultural and other relevant interests in the District,
PETER JOHN HEARD, being a person elected to represent grazing, agricultural and other relevant interests in the District,
ARTHUR ROLLET GROSS, being a person elected to represent grazing, agricultural and other relevant interests in the District,
LESLIE WILLIAM LOELIGER, being a person elected to represent grazing, agricultural and other relevant interests in the District,
JOHN DAVID GILLESPIE, being the person representing the Forests Commission, and
IAN RICHARD McALPIN, being the person representing the Soil Conservation Authority,

to be members of the District Advisory Committee of the Southern Wimmera Soil Conservation District for a term of three years pursuant to section 15 of the *Soil Conservation and Land Utilization Act 1958*.

HEALTH COMMISSION

Member of Committee of Management of a Hospital

WARREN ERNEST HALL, Th.L., Dip.R.E.,
to be a Member of the Committee of Management of the Maldon Hospital pursuant to the provisions of section 63 (F) (1) of the *Hospitals and Charities Act 1958* for a period of three years commencing 12 May 1981.

Superintendent

TERENCE MARK HARDIKER, M.B., Ch.B., D.Obst., R.C.O.G., D.C.H., D.P.M., M.R.A.N.Z.C.P.,
to be Superintendent of the Dandenong Psychiatric Hospital pursuant to the provisions of section 26 (1) of the *Mental Health Act 1959* for the period 5 May 1981 to 17 May 1981, vice Dr. D. P. Leonard, on leave.

Deputy Superintendent

SELWYN ROBERT LEEKS, M.B., Ch.B., D.P.M., M.R.A.N.Z.P., M.R.C.Psych., Dip.Ch.Psy.,
to be Deputy Superintendent of the Dandenong Psychiatric Hospital pursuant to the provisions of section 26 (1) of the *Mental Health Act 1959* for the period 5 May 1981 to 17 May 1981, vice Dr. T. M. Hardiker, higher duties.

Trustees of Public Cemeteries

TREVOR RICHARDS
to be a Trustee of the Glenpatrick Public Cemetery, vice J. G. Kaye, deceased,
PETER STANLEY BARR
to be a Trustee of the Woorndoo Public Cemetery, vice E. A. Gale, resigned,
JOHN NEWTON MITCHELL
to be a Trustee of the Colac Public Cemetery, vice P. G. Collyer, deceased,
TERENCE FRANCIS LONG
to be a Trustee of the Timor Public Cemetery, vice W. A. Long, deceased, and
ROY SAVIGE
to be a Trustee of the Narracan Public Cemetery, vice N. L. Savige, resigned, pursuant to section 3 (1) of the *Cemeteries Act 1958*.

LAW DEPARTMENT

Justice of the Peace

KEITH ROBERT WISHART, 71 Wattle Drive, Doveton,
to be a Justice of the Peace for the State of Victoria.

Commissioners for Taking Declarations, &c.

ROBERT JAMES BARTLETT, 283 Normanby Road, Port Melbourne,
KENNETH DOUGLAS DUTHIE, Puckapunyal,
WILLIAM BURGESS FORBES, 32 Donald Street, Blackburn South,
ANTONIO MARINO, 14 Church Street, Morwell,
DEBORAH LEE MAXWELL, 179 Coleman Parade, Glen Waverley,
RUSSELL TURNER STOVALL, 53 Charles Street, North Coburg,
NICHOLAS TELEHUS, 20 Leith Street, Newborough, and
ALLAN ALFRED YOLE, Unit 124, Walmesley Village, Greeves Drive, Kilsyth,
to be Commissioners for taking Declarations and Affidavits under the *Evidence Act 1958*.

MINISTRY FOR POLICE AND EMERGENCY SERVICES

Member of the Road Safety and Traffic Authority

RICHARD JOHN MARTIN, Q.P.M.,
to be a Member of the Road Safety and Traffic Authority pursuant to the provisions of the *Road Traffic Act 1958*, for the period ending 15 February 1983.

TOM FORRISTAL

Clerk of the Executive Council

At the Executive Council Chamber
Melbourne, 12 May 1981

MENTAL HEALTH ACT 1959, SECTION 26

Notice is hereby given that the following appointment has been made pursuant to section 26 of the *Mental Health Act 1959*.

JULIE ANN SMITH

Deputy Manager, Royal Park Psychiatric Hospital as from 5 May 1981, vice W. R. R. Dobson, transferred.

Dated 11 May 1981

G. TREVAKS, Chairman
Health Commission of Victoria

Community Welfare Services Act 1970

SUMMONING OFFICER

Pursuant to section 74b of the *Community Welfare Services Act 1970*, I hereby appoint—

ADRIAN JOHN PADFIELD
as a Summoning Officer.

WALTER JONA
Minister for Community Welfare Services

MENTAL HEALTH ACT 1959, SECTION 26

Notice is hereby given that the following appointment has been made pursuant to section 26 of the *Mental Health Act 1959*.

JAMES GORDON HYATT,
Manager, Repatriation Mental Hospital, Bundoora as from 25 April 1981, vice C. E. Norden, transferred.
14 May 1981

G. TREVAKS, Chairman
Health Commission of Victoria

Liquor Control Act 1968

APPOINTMENT OF LICENSING INSPECTORS

In accordance with the authority conferred upon me by Section 6 of the *Police Regulation Act 1958*, I, David John Swanson, Deputy Commissioner of Police, do hereby appoint under sub-section (1) of Section 22 of the *Liquor Control Act 1968*, the following Officer of Police as a Licensing Inspector for the Division of the Police District as shown:—

Division Number	Police District	Rank and Name
1	Westernport	Inspector William Bruce Cooke (from 14.6.81 to 11.7.81)

14.5.1981
D. J. SWANSON
Deputy Commissioner (Administration)

RESIGNATIONS

His Excellency the Governor of the State of Victoria by and with the advice of the Executive Council thereof has by Orders made on 12 May 1981 accepted the resignations of the persons named hereunder of the offices mentioned, viz.:

DEPARTMENT OF COMMUNITY WELFARE SERVICES

Honorary Probation Officers

JOHN WILLIAM BEACHAM, Lancaster,
CATHERINE MARGARET BLACKMAN, Oakleigh East,
DOROTHY MAY BROWN, North Balwyn,
JAMES STEVEN BUCK, Shepparton,
PATRICK JOSEPH COLLINS, Tatura,
KEVIN PATRICK GORMAN, Belmont,
PETER PAUL KAN, Lara,
JANITA DOROTHY LACHOWICZ, Hawthorn East,
ELIZABETH D., McCONNAN, Hawthorn East,
IAN THOMAS McDONALD, Maryborough,
JOHN LINDSAY MCKIBBIN, Northcote,
THOMAS NESBIT MCMULLAN, Keon Park,
ARTHUR ROBERT RITCHIE, Maryborough,

JOHN MICHAEL RUSH, Sunbury,
NEVILLE SAUNDERS, Kingsbury,
BRUCE FREDERICK STANTON, Ivanhoe,
MARGARET JOAN STAPLEHURST, Coburg,
BARBARA WARREN, Glenroy,
RAYMOND WARREN, Glenroy, and
LEO PATRICK HALLORAN, Castlemaine,
as Honorary Probation Officers pursuant to the provisions of section 507 (2) of the *Crimes Act 1958* and section 9 of the *Children's Court Act 1973* for all Adult and Children's Courts in Victoria.

HEALTH COMMISSION

Members of Committees of Management of Hospitals

MARY AGNES REBECCA SMITH, as a Member of the Committee of Management, Wimmera Base Hospital, as from 16 March 1981.

RAY PROSSER, as a Member of the Committee of Management, Korumburra District Hospital, as from 21 April 1981.

LAW DEPARTMENT

Justice of the Peace

KENNETH PETER KESTELL-BUSCOMBE
as a Justice of the Peace for the State of Victoria.
Commissioners for Taking Declarations, &c.

JOY ELIZABETH CLARK,
EVAN JOHN DAVIES,
THOMAS DYER,
BRUCE CLEMENT MASON,
HILARY EVERARD VERNON METZELING,
CHARLES FREDERICK REDFORD,
ANNIE TALLENT,
KEITH TURNER,
LORNA ISABEL WAREHAM, and
KEITH ROBERT WISHART,
as Commissioners for taking Declarations and Affidavits under the *Evidence Act 1958*.

POLICE AND EMERGENCY SERVICES

Member of the Road Safety and Traffic Authority

JOSEPH DISHER DARLEY
as a Member of the Road Safety and Traffic Authority pursuant to the provisions of the *Road Traffic Act 1958*.

TOM FORRISTAL
Clerk of the Executive Council

At the Executive Council Chamber,
Melbourne, 12 May 1981

ORDERS IN COUNCIL

LOCAL GOVERNMENT ACT 1958

At the Executive Council Chamber, Melbourne, the fourteenth day of April, 1981

PRESENT:

His Excellency the Governor of Victoria
Mr Borthwick | Mr Jona
Mr Ramsay | Mr Lacy

VESTING OF RESERVES IN THE FLINDERS SHIRE COUNCIL

Whereas it is provided by section 569BA of the *Local Government Act 1958*, that where any map or plan has been lodged or deposited with the Registrar of Titles pursuant to section 97 of the *Transfer of Land Act 1958*, or any corresponding previous enactment (whether before or after the commencement of the *Local Government Act*

1963) and any allotment on that map or plan has been transferred the Governor in Council on the request of the Council of the municipality may by Order published in the *Government Gazette* direct that the whole or any part of the land comprised in any reserve shown on that map shall vest in the council whereupon such land shall so vest freed and discharged from any mortgage charge lease or sub-lease.

And whereas the Council of the Shire of Flinders has requested that reserves shown on a plan of subdivision be vested in the Council and an allotment on that plan has been transferred.

Now therefore, His Excellency the Governor of the State of Victoria, by and with the advice of the Executive Council thereof, and in pursuance of the provisions of sub-section 1 of section 569BA of the *Local Government Act 1958* doth by this Order vest in the Council of the Shire of Flinders the Park and Drainage Reserves on Plan of Subdivision No. 9972 lodged in the Office of Titles being the land shown by hatching on the attached plan.

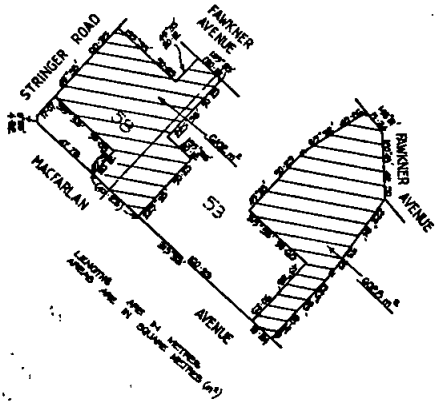

And the Honourable Digby Glen Crozier, Her Majesty's Minister for Local Government for the State of Victoria, shall give the necessary directions herein accordingly.

TOM FORRISTAL
Clerk of the Executive Council

NOTE—This notice is published in lieu of the notice appearing in *Government Gazette* No. 35 of 24 April 1981 on page 1325.

STATE ELECTRICITY COMMISSION ACT 1958

At the Executive Council Chamber, Melbourne, the fifth day of May, 1981

PRESENT:
His Excellency the Governor of Victoria
Mr Houghton | Mr Maclellan
Mr Lieberman | Mr Kennett

ELECTRICAL APPROVALS REGULATIONS—
PROCEEDINGS OF ELECTRICAL APPROVALS BOARD
(AMENDMENT) 1981

Pursuant to the powers conferred by the *State Electricity Commission Act 1958* and all other powers him thereunto enabling His Excellency the Governor of the State of Victoria, acting by and with the advice of the Executive Council thereof, doth hereby, on the recommendation of the State Electricity Commission of Victoria, make the following Regulations, that is to say:

1. (1) These Regulations may be cited as the *Electrical Approvals Regulations—Proceedings of Electrical Approvals Board (Amendment) 1981* and shall come into operation on 1 May 1981.

(2) In these Regulations the *Electrical Approvals Regulations—Proceedings of Electrical Approvals Board 1934* are called the *Principal Regulations*.

2. In paragraph (a) of Regulation 9 of the *Principal Regulations* for the words "One thousand eight hundred and sixty dollars" there shall be substituted the expression "Two thousand and eleven dollars".

And the Honourable Louis Stuart Lieberman, Her Majesty's Minister for Minerals and Energy for the State of Victoria, shall give the necessary directions herein accordingly.

TOM FORRISTAL
Clerk of the Executive Council

CROWN LAND (RESERVES) ACT 1978

At the Executive Council Chamber, Melbourne, the fifth day of May, 1981

PRESENT:
His Excellency the Governor of Victoria
Mr Houghton | Mr Maclellan
Mr Lieberman | Mr Kennett

CROWN LANDS PERMANENTLY RESERVED

His Excellency the Governor of the State of Victoria, in the Commonwealth of Australia, by and with the advice of the Executive Council of the said State, pursuant to the provisions of section 4 and 7 of the *Crown Land (Reserves) Act 1978*, and being of the opinion that the Crown lands concerned are required for the purposes respectively mentioned, doth hereby permanently reserve and also except from occupation for mining purposes under any miner's right, the Crown lands hereinafter described, viz.:

BAMBRA—For Conservation of an Area of Natural Interest—10.9 hectares, more or less, being Crown allotment 51H, Parish of Bamba, as indicated by hatching on plan hereunder—(B.90(p²)) (Rs.11341).

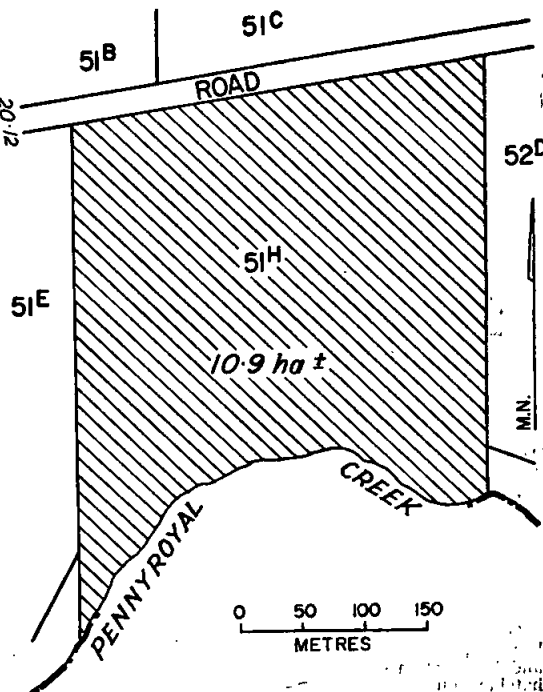

ELYAR—For the Management of Wildlife—107 hectares, more or less, being Crown allotment 112A, Parish of Eilyar, as indicated by hatching on plan hereunder—(E.20(A²) (Rs. 11295).

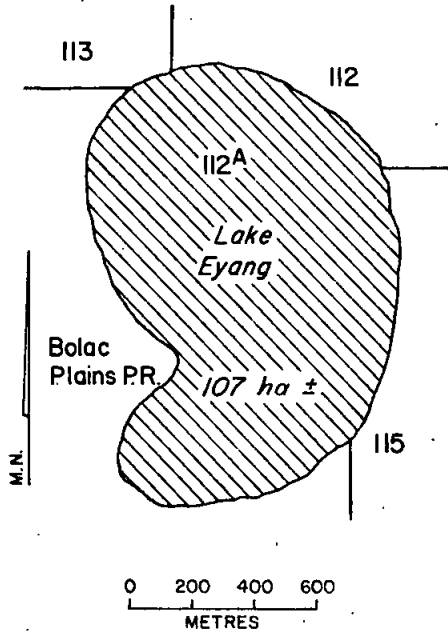

ORBOST EAST—For Preservation of Species of Native Plants—44 hectares, more or less, being Crown allotment 19c, Section C, Parish of Orbost East, as indicated by hatching on plan hereunder—(O.23⁽¹¹⁾) (Rs.10968).

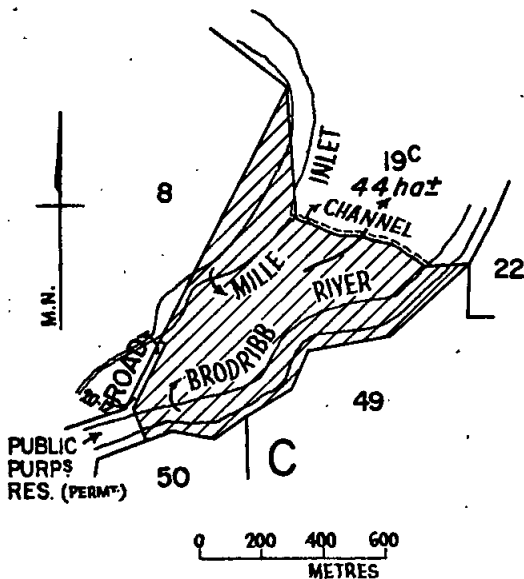

ORBOST EAST—For the Management of Wildlife—950 hectares, more or less, being Crown allotments 19a, 19b and 19e, section C, Parish of Orbost East, as indicated by hatching on plan hereunder—(O.23⁽¹¹⁾) (Rs.8344).

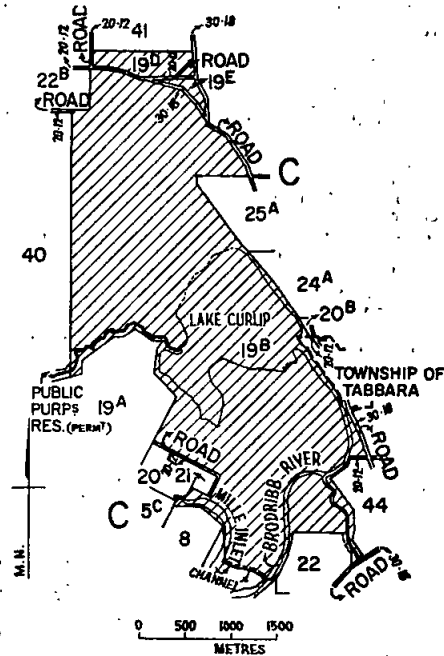

Total area of hatched portions 950 ha±

TABBARA—For the Management of Wildlife—11 hectares, more or less, being Crown allotments 8 and 9, section 3, Township of Tabbara, as indicated by hatching on plan hereunder—(T.261(*) (Rs.8344).

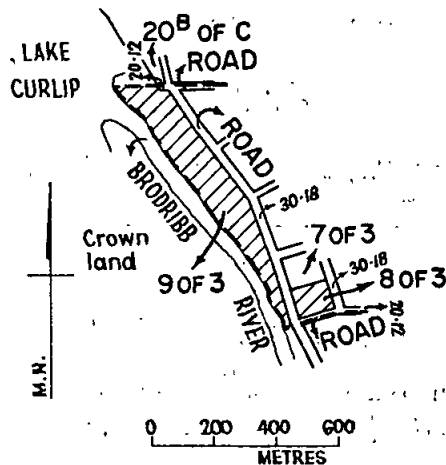

Total area of hatched portions 11 ha±

And the Honourable William Vasey Houghton, Her Majesty's Minister of Lands for the State of Victoria, shall give the necessary directions herein accordingly.

TOM FORRISTAL,
Clerk of the Executive Council

NOTE—This notice is in lieu of notice titled "Crown Land Temporarily Reserved" appearing on pages 1529 and 1530 of Government Gazette dated 13 May 1981

Water Act 1958

STATE RIVERS AND WATER SUPPLY COMMISSION

At the Executive Council Chamber, Melbourne, the
twelfth day of May, 1981

PRESENT:

His Excellency the Governor of Victoria

Mr Crozier	Mr Jona
Mr Ramsay	Mr Austin

**GOULBURN-MURRAY IRRIGATION DISTRICT—
PORTIONS EXCISED—SHEPPARTON IRRIGATION
AREA—BOUNDARIES VARIED**

Under the powers conferred by the Water Act 1958 and all other powers enabling him in that behalf, His Excellency the Governor of the State of Victoria, with the advice of the Executive Council of the said State, on the recommendation of the State Rivers and Water Supply Commission, doth hereby declare, order and direct that there shall be excised from the Goulburn-Murray Irrigation District the lands shown by green colour on a plan approved by the Governor in Council and deposited in the office of the State Rivers and Water Supply Commission at 590 Orrong Road, Armadale (Corr. No.'s 69/1278, 74/4566, 77/155, 77/180, 79/3817, 80/354, 80/1666, 80/1762, 80/2066, 80/2815) and that the boundaries of the Shepparton Irrigation Area shall be varied to excise therefrom such lands which shall be deemed to be excised from the said Irrigation District and Irrigation Area as on and from 31 May 1981.

And the Honourable Frederick James Granter, Her Majesty's Minister of Water Supply for the State of Victoria, shall give the necessary directions herein accordingly.

TOM FORRISTAL
Clerk of the Executive Council

Water Act 1958

STATE RIVERS AND WATER SUPPLY COMMISSION

At the Executive Council Chamber, Melbourne, the
twelfth day of May, 1981

PRESENT:

His Excellency the Governor of Victoria

Mr Crozier	Mr Jona
Mr Ramsay	Mr Austin

**BELLARINE URBAN DISTRICT—AREA OF DISTRICT
DIMINISHED**

Under the powers conferred by the Water Act 1958, and all other powers enabling him in that behalf, His Excellency the Governor of the State of Victoria, with the advice of the Executive Council of the said State, on the recommendation of the State Rivers and Water Supply Commission, doth hereby declare, order and direct that the area of the Bellarine Urban District be diminished by excising there from the portion of the same by green colour on a plan approved by the Governor in Council and deposited in the Office of the State Rivers and Water Supply Commission at 590 Orrong Road, Armadale (Corr. No. 76/2343) and as on and from 31 May 1981, such portion shall be deemed to be excised accordingly.

And the Honourable Frederick James Granter, Her Majesty's Minister of Water Supply for the State of Victoria, shall give the necessary directions herein accordingly.

TOM FORRISTAL
Clerk of the Executive Council

WATER ACT 1958

At the Executive Council Chamber, Melbourne, the
twelfth day of May, 1981

PRESENT:

His Excellency the Governor of Victoria

Mr Crozier	Mr Jona
Mr Ramsay	Mr Austin

**SHEPPARTON WATERWORKS TRUST—EXTENT OF
WATERWORKS DISTRICT AND AREA OF
SHEPPARTON URBAN DISTRICT INCREASED**

Under the powers conferred by the Water Act 1958 and all other powers enabling him in that behalf, His Excellency the Governor of the State of Victoria, with the advice of the Executive Council of the said State, doth hereby declare, order and direct that the extent of the Waterworks District of the Shepparton Waterworks Trust and the area of the Shepparton Urban District of the said Trust be increased by adding to the said Districts the lands shown by blue colour on a plan approved by the Governor in Council and deposited in the office of the State Rivers and Water Supply Commission at 590 Orrong Road, Armadale (Corr. No.'s 69/1278, 74/4566, 71/155, 77/180, 79/3817, 80/354, 80/1666, 80/1762, 80/2066, 80/2815) and as on and from 1 June 1981, the extent of the said Waterworks District and the area of the said Urban District shall be deemed to be so increased.

And the Honourable Frederick James Granter, Her Majesty's Minister of Water Supply for the State of Victoria, shall give the necessary directions herein accordingly.

TOM FORRISTAL
Clerk of the Executive Council

**FIRST MILDURA IRRIGATION TRUST
MILDURA URBAN WATER TRUST**

At the Executive Council Chamber, Melbourne, the
twelfth day of May, 1981

PRESENT:

His Excellency the Governor of Victoria

Mr Crozier	Mr Jona
Mr Ramsay	Mr Austin

**SEVERANCE OF PORTION OF THE FIRST MILDURA
IRRIGATION TRUST DISTRICT AND ANNEXATION TO
THE MILDURA URBAN WATER TRUST DISTRICT**

Under the powers conferred by the Mildura Irrigation and Water Trusts Act and all other powers enabling him in that behalf, His Excellency the Governor of the State of Victoria, by and with the advice of the Executive Council of the said State, doth hereby declare, order and direct that as on and from the date hereof the lands shown by red colour on the plans marked "A" and "B" approved by the Governor in Council and deposited in the office of the State Rivers and Water Supply Commission, Melbourne (Corr. No. 80/4325/3), shall be severed from the District of the First Mildura Irrigation Trust and annexed to the District of the Mildura Urban Water Trust.

And the Honourable Frederick James Granter, Her Majesty's Minister of Water Supply for the State of Victoria, shall give the necessary directions herein accordingly.

TOM FORRISTAL
Clerk of the Executive Council

COAL MINES ACT 1958

At the Executive Council Chamber, Melbourne, the
twelfth day of May, 1981

PRESENT:

His Excellency the Governor of Victoria
Mr Crozier | Mr Jona
Mr Ramsay | Mr Austin

CHANGES IN RATES OF PENSIONS PAYABLE UNDER
PART III OF COAL MINES ACT 1958

Whereas it is provided in section 110 of the *Coal Mines Act 1958* that whenever rates of Commonwealth pensions are increased, rates of pensions payable under Part III of the *Coal Mines Act 1958* shall be increased and that whenever rates of pensions are increased by the operation of that provision the Governor in Council may, by Order published in the *Government Gazette*, declare those rates to be the rates payable under the said Part.

And whereas rates of Commonwealth pensions have been increased from 7 May 1981.

Now therefore, I, the Governor of the State of Victoria, by and with the advice of the Executive Council thereof, do by this Order declare the rates of pension shown hereunder to be the rates of pension payable under the several provisions of the said Part.

\$71.90, section 104.
\$71.90, section 105.
\$47.20, paragraphs (a) and (c) of section 106.
\$10.00, paragraph (b) of section 106.
\$70.90, sub-sections (1) and (1A) of section 107.

And the Honourable L. S. Lieberman, Her Majesty's Minister for Minerals and Energy for the State of Victoria, shall give the necessary directions herein accordingly.

TOM FORRISTAL
Clerk of the Executive Council

SUPERANNUATION ACT 1958

At the Executive Council Chamber, Melbourne, the
twelfth day of May, 1981

PRESENT:

His Excellency the Governor of Victoria
Mr Crozier | Mr Jona
Mr Ramsay | Mr Austin

Pursuant to the powers conferred by the provisions of paragraph (a) of sub-section (1) of section 3 of the *Superannuation Act 1958*, His Excellency the Governor of the State of Victoria, by and with the advice of the Executive Council thereof, do by this Order declare that the provisions of the *Superannuation Act* shall apply to the officers named in the schedule set out hereunder.

SCHEDULE

GRASBY, LYNETTE ALICE, Gippsland Institute of Advanced Education.
HARTUNG, WOLFGANG, State College of Victoria, Rusden.
GATES, RUSSELL SCOTT, Warrnambool Institute of Advanced Education.

And the Honourable Lindsay Hamilton Simpson Thompson, Her Majesty's Treasurer for the State of Victoria, shall give the necessary directions herein accordingly.

TOM FORRISTAL
Clerk of the Executive Council

LOCAL GOVERNMENT ACT 1958

At the Executive Council Chamber, Melbourne, the
twelfth day of May, 1981

PRESENT:

His Excellency the Governor of Victoria
Mr Crozier | Mr Jona
Mr Ramsay | Mr Austin

CONFIRMATION OF SEPARATE RATE—CITY OF
SANDRINGHAM

In pursuance of the provisions of section 287 of the *Local Government Act 1958*, His Excellency the Governor of the State of Victoria, by and with the advice of the Executive Council thereof, hereby confirms a separate rate of zero point one three four (0.134) cents in the dollar on the site value of the properties described in Schedule "A" hereunder and zero point two six eight (0.268) cents in the dollar on the site value of the properties described in Schedule "B" hereunder which rate was made by the Council of the City of Sandringham on 23 February 1981 for the purpose of providing off-street parking facilities for use in connection with the Hampton Shopping Centre.

SCHEDULE "A"

Properties to be rated at 0.134 cents in the dollar—

Hampton Street, Hampton—No's. 305, 307, 309/311, 313, 315, 317, 319, 321, 323, 325, 327, 329/331, 333A, 333, 335, 337, 339, 341, 343, 345/347, 349, 351, 353, 355/363, 365, 367, 369, 371, 373, 375, 377, 379/381, 400, 402, 404, 406, 408A, 408, 410, 412, 414, 416, 418, 420, 422, 424, 426, 428, 430, 432, 434, 436, 438, 442, 444, 446, 448, 450, 452, 488/498, 500, 502, 504, 506/508, and 510/512.

SCHEDULE "B"

Properties to be rated at 0.268 cents in the dollar.

Hampton Street, Hampton—No's. 383, 385, 387, 389, 391, 393, 395, 397, 399, 401, 403, 405, 407, 409, 411 (Shop), 411 (dwelling), 413, 415, 417 (Shops 1, 2, 3, 4 and 5), 421/423, 425, 456, 458, 460, 462, 464, 466, 468, 470, 472/474, 476, 476, 478, 480, 482, 484, and 486.
Mills Street, Hampton—No's. 2A and 2B.

And the Honourable Digby Glen Crozier, Her Majesty's Minister for Local Government for the State of Victoria, shall give the necessary directions herein accordingly.

TOM FORRISTAL
Clerk of the Executive Council

LOCAL GOVERNMENT ACT 1958

At the Executive Council Chamber, Melbourne, the
twelfth day of May, 1981

PRESENT:

His Excellency the Governor of Victoria
Mr Crozier | Mr Jona
Mr Ramsay | Mr Austin

CONFIRMATION OF SEPARATE RATE—CITY OF
CAMBERWELL

In pursuance of the provisions of section 287 of the *Local Government Act 1958*, His Excellency the Governor of the State of Victoria, by and with the advice of the Executive Council thereof, hereby confirms a separate rate of zero point three four eight nine one three (0.348913) cents in the dollar on the site value of the properties described in Schedule "A" hereunder and zero point six nine seven eight two six (0.697826) cents in the dollar on the site value of the properties described in Schedule "B" hereunder which rate was made by the Council of the City of

Camberwell on 15 May 1978 for the purpose of providing off-street parking facilities for use in connection with the Village Shopping Centre in Doncaster Road, Balwyn North.

SCHEDULE "A"

Properties to be rated at 0.348913 cents in the dollar—
Doncaster Road, North Balwyn No.'s 76A and 78.

SCHEDULE "B"

Properties to be rated at 0.697826 cents in the dollar—
Doncaster Road, North Balwyn—No.'s 60, 62/64, 66, 66A, 66A (rear), 66B, 66C, 68 (premises 1 and 2), 68A, 68B, 70, 70A (premises 1, 2, 3, 4, 5, 6, 7 and 8), 70B, 70C, 72, 72A, 74, 76, 61, 61A, 63, 65, 67, 69, 71, 73, 75, 77, 79, 81, 83, 85, 87, 89 and 91/93.

And the Honourable Digby Glen Crozier, Her Majesty's Minister for Local Government for the State of Victoria, shall give the necessary directions herein accordingly.

TOM FORRISTAL
Clerk of the Executive Council

LOCAL GOVERNMENT ACT 1958

At the Executive Council Chamber, Melbourne, the twelfth day of May, 1981

PRESENT:

His Excellency the Governor of Victoria

Mr Crozier Mr Jona
Mr Ramsay Mr Austin

ROAD DISCONTINUED—SHIRE OF LILLYDALE

Whereas it is provided in section 528 (2) of the Local Government Act 1958, that where a road (whether or not a public highway, but not being a road set out on land of the Crown) or any part thereof is not required for public use the Governor in Council on the request of the council of the municipality in which such road is situated made not less than one month after publishing in a newspaper generally circulating in the district and posting to the registered proprietor (if any) of the land and the owners and occupiers (if any) of lands abutting or immediately adjacent to the road notice of intention to make such a request may by Order published in the Government Gazette direct that such road or part shall be discontinued and thereupon such road or part shall be discontinued accordingly.

And whereas it is further provided that where a planning scheme under the Town and Country Planning Act 1961 provides for the closing of a road or part of a road and notice of approval of the planning scheme has been published in the Government Gazette it shall not be necessary for the Council to publish or to post to any person notice of its intention to request the Governor in Council to discontinue such road or part thereof.

And whereas the Lillydale Planning Scheme 1958, Amendment No. 107 provides that part of George Street, Mooroolbark is not required for public use and notice of approval of the planning scheme was published in the Government Gazette on 28 November 1979.

And whereas the Council of the Shire of Lillydale has requested that the Governor in Council direct that the said part of a road be discontinued.

Now therefore, His Excellency the Governor of the State of Victoria, by and with the advice of the Executive Council thereof, hereby directs:

- (a) that the said part of a road which is shown by hatching and cross hatching on the plan hereunder, shall be discontinued;
- (b) that notwithstanding such discontinuance the Australian Telecommunications Commission shall continue to have and possess the same right title power authority or interest in or in relation to the

whole of the land shown by cross hatching on the said plan as it had or possessed prior to such discontinuance with respect to or in connection with any wires or cables laid or erected in on or over such land for the purposes of telecommunication; and

- (c) that, subject to any such right title power authority or interest, the land in the said part of a road may be sold by the Council of the Shire of Lillydale by agreement.

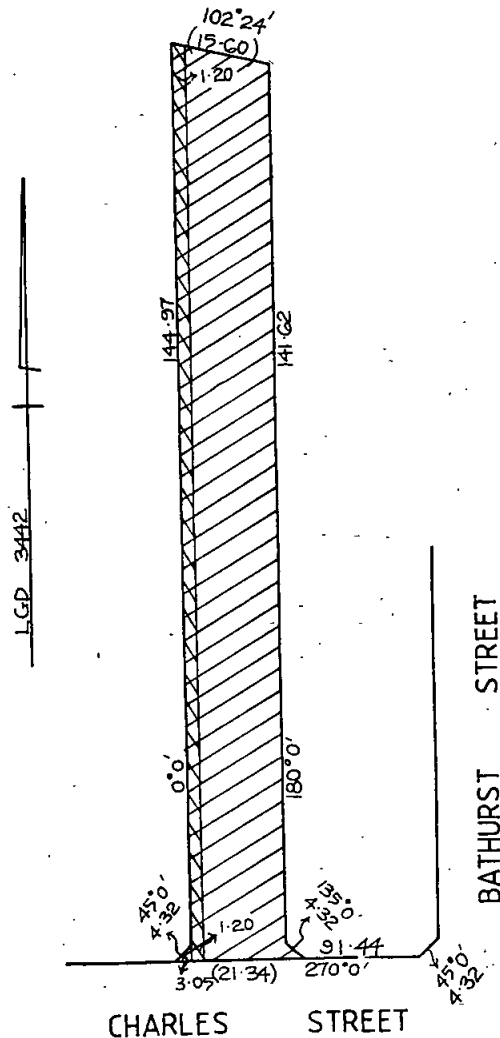

LENGTHS ARE IN METRES

And the Honourable Digby Glen Crozier, Her Majesty's Minister for Local Government for the State of Victoria, shall give the necessary directions herein accordingly.

TOM FORRISTAL
Clerk of the Executive Council

This Order is in lieu of the Order published in the Government Gazette on 4 February 1981

LOCAL GOVERNMENT ACT 1958

At the Executive Council Chamber, Melbourne, the twelfth day of May, 1981

PRESENT:

His Excellency the Governor of Victoria
 Mr Crozier | Mr Jona
 Mr Ramsay | Mr Austin

ROAD DISCONTINUED—SHIRE OF PAKENHAM

Whereas it is provided in section 528 (2) of the *Local Government Act 1958*, that where a road (whether or not a public highway but not being a road set out on land of the Crown) or any part thereof is not required for public use, the Governor in Council on the request of the council of the municipality in which such road is situated made not less than one month after publishing in a newspaper generally circulating in the district and posting to the registered proprietor (if any) of the land and the owners and occupiers (if any) of lands abutting or immediately adjacent to the road notice of intention to make such a request may by Order published in the *Government Gazette* direct that such road or part shall be discontinued and thereupon such road or part shall be discontinued accordingly.

And whereas the Council of the Shire of Pakenham has requested that the Governor in Council direct that a road off Young Street, Upper Beaconsfield be discontinued and not less than one month previously has published in a newspaper generally circulating to the district and posted to the registered proprietor of the land in the road and to the owners and occupiers of lands abutting or immediately adjacent to the road notice of intention to make such a request.

Now therefore, His Excellency the Governor of the State of Victoria, by and with the advice of the Executive Council thereof, hereby directs that the said road which is shown by hatching on the plan hereunder, shall be discontinued and that the land may be sold by the Council of the Shire of Pakenham by agreement.

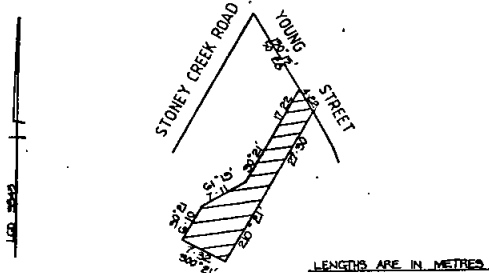

And the Honourable Digby Glen Crozier, Her Majesty's Minister for Local Government for the State of Victoria shall give the necessary directions herein accordingly.

TOM FORRISTAL
 Clerk of the Executive Council

LOCAL GOVERNMENT ACT 1958

At the Executive Council Chamber, Melbourne, the twelfth day of May, 1981

PRESENT:

His Excellency the Governor of Victoria
 Mr Crozier | Mr Jona
 Mr Ramsay | Mr Austin

ROAD DISCONTINUED—CITY OF SANDRINGHAM

Whereas it is provided in section 528 (2) of the *Local Government Act 1958* that where a road (whether or not a public highway but not being a road set out on land of the Crown) or any part thereof is not required for public

use the Governor in Council on the request of the council of the municipality in which such road is situated made not less than one month after publishing in a newspaper generally circulating in the district and posting to the registered proprietor (if any) of the land and the owners and occupiers (if any) of lands abutting or immediately adjacent to the road notice of intention to make such a request may by Order published in the *Government Gazette* direct that such road or part shall be discontinued and thereupon such road or part shall be discontinued accordingly.

And whereas the Council of the City of Sandringham has requested that the Governor in Council direct that part of a road off Red Bluff Street, Sandringham be discontinued and not less than one month previously has published in a newspaper generally circulating in the district and posted to the registered proprietor of the land in the road and to the owners and occupiers of lands abutting or immediately adjacent to the road notice of intention to make such request.

Now therefore, His Excellency the Governor of the State of Victoria, by and with the advice of the Executive Council thereof, hereby directs:—

- (a) that the said part of a road which is shown by hatching on the plan hereunder shall be discontinued;
- (b) that notwithstanding such discontinuance the Melbourne and Metropolitan Board of Works shall continue to have and possess the same right title power authority or interest in or in relation to the whole of the land shown by hatching on the said plan as it had or possessed prior to such discontinuance with respect to or in connection with any drains or pipes laid or erected in on or over such land for the purpose of drainage or sewerage; and
- (c) that, subject to any such right title power authority or interest the land in the said part of a road may be sold by the Council of the City of Sandringham by agreement.

EDWARD STREET

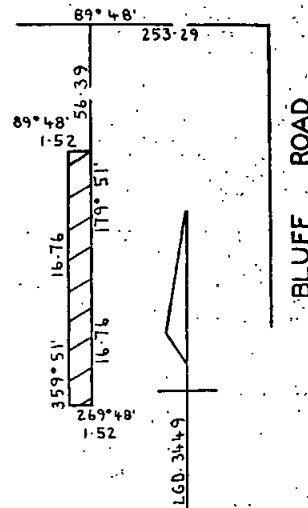

And the Honourable Digby Glen Crozier, Her Majesty's Minister for Local Government for the State of Victoria, shall give the necessary directions herein accordingly.

TOM FORRISTAL
 Clerk of the Executive Council

CROWN LAND (RESERVES) ACT 1978

At the Executive Council Chamber, Melbourne, the twelfth day of May, 1981

PRESENT:

His Excellency the Governor of Victoria
 Mr Crozier | Mr Jona
 Mr Ramsay | Mr Austin

REVOCATION OF TEMPORARY RESERVATIONS OF LANDS BY ORDERS IN COUNCIL

His Excellency the Governor of the State of Victoria, in the Commonwealth of Australia, by and with the advice of the Executive Council of the said State, pursuant to the provisions of section 10 of the Crown Land (Reserves) Act 1978, doth hereby revoke the temporary reservations of lands by Orders in Council hereinafter described, viz.:

CHATSWORTH—The temporary reservation by Order in Council of 26 March 1872 of 8094 square metres of land in the Township of Chatsworth (in section 13) as a site for Common School purposes—(C.201(*) (Rs.7008).

KEILAMBETE—The temporary reservation by Order in Council of 1 April 1941 of 4.249 hectares of land in the Parish of Keilambete (called Parish of Terang in Order) (near Lake Keilambete) as a site for Public Recreation and Watering purposes—(K.30A) (*) (Rs.5184).

WINNAMBOOL—The temporary reservation by Order in Council of 11 September 1928 of 1.62 hectares of land in the Parish of Winnambool (north-east of allotment 19c) as a site for State School purposes—(Rs.3746).

DEREEL—The temporary reservation by Order in Council of 29 December 1921 of 4047 square metres of land in the Township of Dereel as a site for a Public Hall, so far only as the portion thereof containing 360 square metres, as defined by description and hatching on plan published in the Government Gazette dated 24 April 1981, is concerned—(D.172(*) (Rs.6463).

TINAMBA—The temporary reservation by Order in Council of 17 November 1970 of 14.41 hectares of land in the Parish of Tinamba as a site for Public Recreation, so far only as the portions thereof containing 1113 square metres, as defined by description and hatching on plan published in the Government Gazette dated 24 April 1981, are concerned—(T.147(*) (Rs.9392).

And the Honourable William Vasey Houghton, Her Majesty's Minister of Lands for the State of Victoria, shall give the necessary directions herein accordingly.

TOM FORRISTAL
 Clerk of the Executive Council

CROWN LAND (RESERVES) ACT 1978

At the Executive Council Chamber, Melbourne, the twelfth day of May, 1981

PRESENT:

His Excellency the Governor of Victoria
 Mr Crozier | Mr Jona
 Mr Ramsay | Mr Austin

CROWN LAND TEMPORARILY RESERVED

His Excellency the Governor of the State of Victoria, in the Commonwealth of Australia, by and with the advice of the Executive Council of the said State, pursuant to the provisions of sections 4 and 7 of the Crown Land (Reserves) Act 1978, and being of the opinion that the Crown land concerned is required for the public purpose mentioned, doth hereby temporarily reserve and also except from occupation for mining purposes under any miner's right, the Crown land hereinafter described, viz.:

MALLACOOTA—For Departmental Residence, 613 square metres, being Crown allotment 1E, Parish of Mallacoota, as indicated by hatching on plan hereunder—(M.550(*) (Rs.11428).

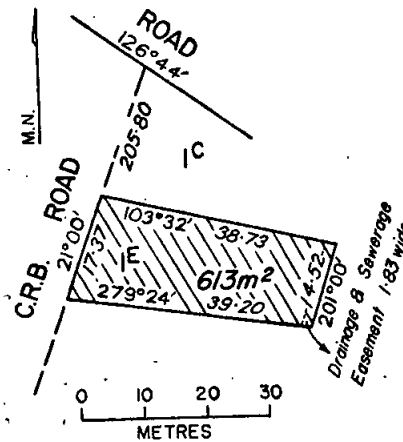

And the Honourable William Vasey Houghton, Her Majesty's Minister of Lands for the State of Victoria, shall give the necessary directions herein accordingly.

TOM FORRISTAL
 Clerk of the Executive Council

CROWN LAND (RESERVES) ACT 1978

At the Executive Council Chamber, Melbourne, the twelfth day of May, 1981

PRESENT:

His Excellency the Governor of Victoria
 Mr Crozier | Mr Jona
 Mr Ramsay | Mr Austin

CROWN LAND TEMPORARILY RESERVED

His Excellency the Governor of the State of Victoria, in the Commonwealth of Australia, by and with the advice of the Executive Council of the said State, pursuant to the provisions of sections 4 and 7 of the Crown Land (Reserves) Act 1978, and being of the opinion that the Crown land concerned is required for the purpose mentioned, doth hereby temporarily reserve and also except from occupation for mining purposes under any miner's right, the Crown land hereinafter described, viz.:

COLLINGWOOD—For Public Park and Public Recreation, 8.462 hectares, being Crown allotment 42, section 20, at Clifton Hill, City of Collingwood, Parish of Jika Jika, as shown on Certified Plan No. 104928 lodged in the Central Plan-Office—(C.366(*) (Rs.602).

And the Honourable William Vasey Houghton, Her Majesty's Minister of Lands for the State of Victoria, shall give the necessary directions herein accordingly.

TOM FORRISTAL
 Clerk of the Executive Council

CROWN LAND (RESERVES) ACT 1978

At the Executive Council Chamber, Melbourne, the twelfth day of May, 1981

PRESENT:

His Excellency the Governor of Victoria
 Mr Crozier | Mr Jona
 Mr Ramsay | Mr Austin

RESERVED CROWN LAND PLACED UNDER THE CONTROL AND MANAGEMENT OF THE FORESTS COMMISSION

His Excellency the Governor of the State of Victoria, in the Commonwealth of Australia, by and with the advice of the Executive Council of the said State, pursuant to the provisions of section 18 (1) of the Crown Land (Reserves) Act 1978, doth hereby place under the control and management of the Forests Commission, the Crown land hereinafter described, viz.:

EUREKA—The land in the Parish of Eureka, being Crown allotment 49, temporarily reserved for Preservation of Species of Native Plants by Order in Council of 24 February 1981 (see Government Gazette dated 4 March 1981)—(Rs.11182).

And the Honourable William Vasey Houghton, Her Majesty's Minister of Lands for the State of Victoria, shall give the necessary directions herein accordingly.

TOM FORRISTAL
 Clerk of the Executive Council

LAND ACT 1958

At the Executive Council Chamber, Melbourne, the twelfth day of May, 1981

PRESENT:

His Excellency the Governor of Victoria
 Mr Crozier | Mr Jona
 Mr Ramsay | Mr Austin

UNUSED ROADS CLOSED

His Excellency the Governor of the State of Victoria, in the Commonwealth of Australia, by and with the advice of the Executive Council of the said State, pursuant to the provisions of section 349 of the Land Act 1958 and with the concurrence in writing of the council of the municipality concerned and that of any adjoining land owners, doth hereby close the unused roads hereinafter described, viz.:

Municipal District of the Shire of Corio—Parish of Murtaim, being the road indicated by hatching on plan hereunder—(Parish 3241) (L.1-424).

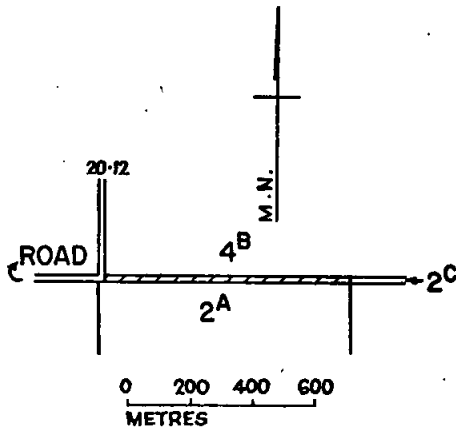

Municipal District of the Shire of Korumburra—Township of Poowong, being the road indicated by hatching on plan hereunder—(P.154^(a)) (L.10-2349).

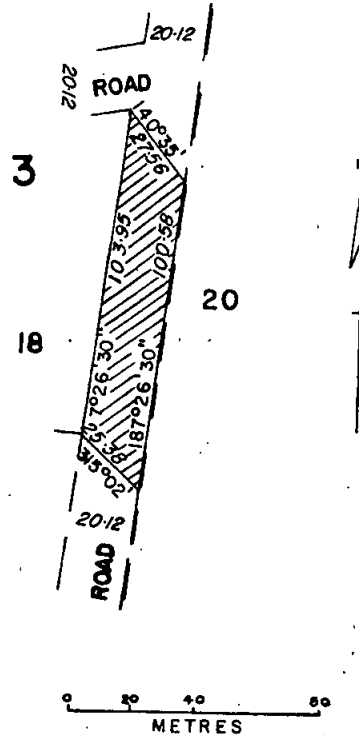

And the Honourable William Vasey Houghton, Her Majesty's Minister of Lands for the State of Victoria, shall give the necessary directions herein accordingly.

TOM FORRISTAL
 Clerk of the Executive Council

COUNTRY ROADS BOARD

Act No. 6229

At the Executive Council Chamber, Melbourne, the twelfth day of May, 1981

PRESENT:

His Excellency the Governor of Victoria
 Mr Crozier | Mr Jona
 Mr Ramsay | Mr Austin

ORDER APPROVING OF LAND BEING ACQUIRED AND ROADS, DEVIATIONS OR WIDENINGS BEING MADE TOGETHER WITH ALL ANCILLARY WORKS REQUIRED TO BE EXECUTED IN CONJUNCTION THEREWITH

His Excellency the Governor of the State of Victoria, by and with the advice of the Executive Council thereof, being satisfied that there are funds legally available for acquiring the land, doth hereby approve the acquiring of the land described in the schedule hereunder and the

making of new roads and deviations from and widenings of existing roads, together with all ancillary works required to be executed in conjunction therewith, referred to in the said schedule.

SCHEDULE
Unclassified Road

The land shown hatched on plans numbered G.P.15053F and G.P.15054C hereunder required for the making of a new road in the Rural City of Wodonga.

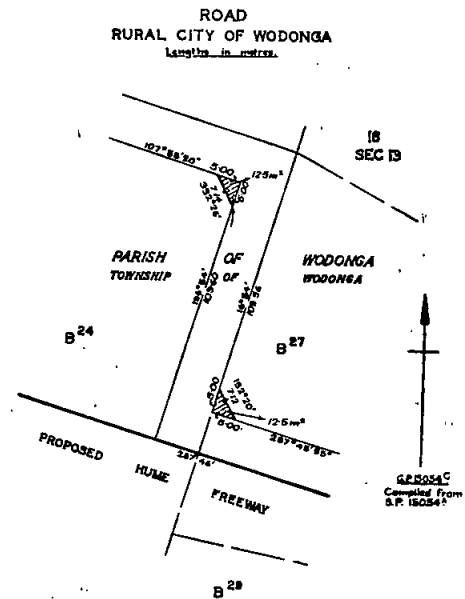
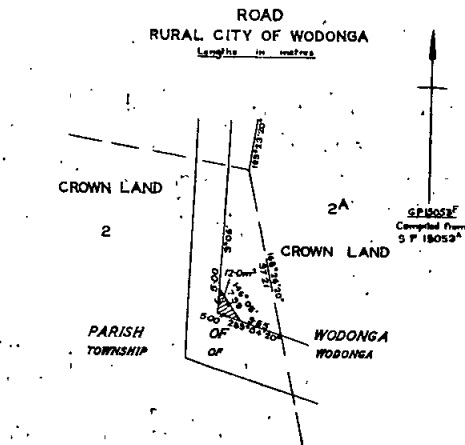

RAILWAY CONSTRUCTION AND PROPERTY BOARD
ACT 1979

At the Executive Council Chamber, Melbourne, the
twelfth day of May, 1981

PRESENT:

His Excellency the Governor of Victoria
Mr Crozier | Mr Jona
Mr Ramsay | Mr Austin

DEVELOPMENT OF RAILWAY LAND

Whereas it is provided by Section 20 (4) of the Railway Construction and Property Board Act 1979 that the Railway Construction and Property Board may make recommendations to the Minister for or with respect to the use or development of railway land.

And whereas it is provided by Section 20 (5) of the said Act that where the Board has made recommendations to the Minister under Section 20 (4) the Minister may submit the recommendations to the Governor in Council for approval.

And whereas the Board has made the following recommendations in respect of Railway land situated at Dandenong and Waverley Roads, Chadstone as shown on the plan hereunder.

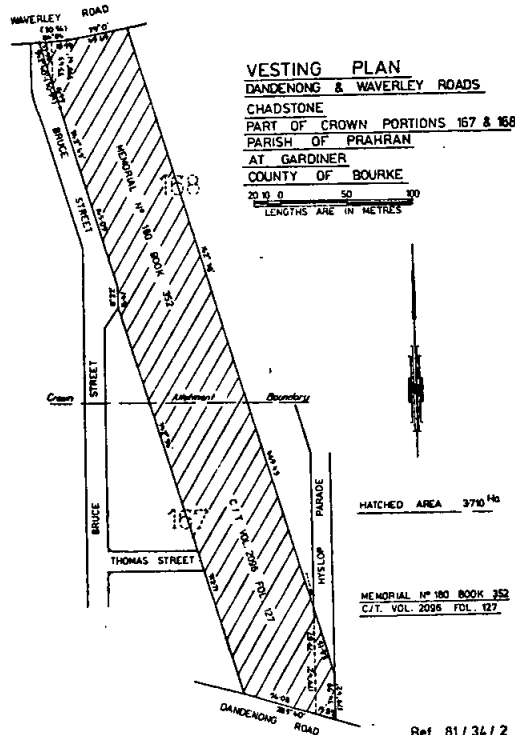

And the Honourable Robert Roy Cameron Maclellan, Her Majesty's Minister of Transport for the State of Victoria, shall give the necessary directions herein accordingly.

TOM FORRISTAL
Clerk of the Executive Council

Recommendation

That the land which is surplus to railway requirements be developed for such road, railway and leisure activities, as may be determined from time to time by the Minister of Transport.

Now therefore His Excellency the Governor of the State of Victoria by and with the advice of the Executive Council thereof, doth hereby approve of the foregoing recommendation.

And the Honourable Robert Roy Cameron Maclellan, Her Majesty's Minister of Transport, for the State of Victoria, shall give the necessary directions therein accordingly.

TOM FORRISTAL
Clerk of the Executive Council

INDUSTRIAL RELATIONS ACT 1979

At the Executive Council Chamber, Melbourne, the twelfth day of May, 1981

PRESENT:

His Excellency the Governor of Victoria	
Mr Crozier	Mr Jona
Mr Ramsay	Mr Austin

APPOINTMENT OF PRESIDENT OF THE INDUSTRIAL RELATIONS COMMISSION

In pursuance of the powers conferred by section 5 of the *Industrial Relations Act 1979*, and all other powers him thereunto enabling, His Excellency the Governor of the State of Victoria, by and with the advice of the Executive Council thereof, doth by this Order appoint—

KEITH DOUGLAS MARSHALL,
a person who is a barrister and solicitor of the High Court of Australia and who is of not less than five years standing to be the President of the Industrial Relations Commission as from and including 2 June 1981.

And the Honourable James Halford Ramsay, Her Majesty's Minister of Labour and Industry for the State of Victoria, shall give the necessary directions herein accordingly.

TOM FORRISTAL
Clerk of the Executive Council

WORKERS COMPENSATION ACT 1958

At the Executive Council Chamber, Melbourne, the twelfth day of May, 1981

PRESENT:

His Excellency the Governor of Victoria	
Mr Crozier	Mr Jona
Mr Ramsay	Mr Austin

WORKERS COMPENSATION BOARD—APPOINTMENT OF JUDICIAL MEMBER

In pursuance of the powers conferred by sub-section (2) of section 80 of the *Workers Compensation Act 1958*, and all other powers him thereunto enabling, His Excellency the Governor of the State of Victoria, by and with the advice of the Executive Council thereof, doth by this Order appoint—

His Honour Judge FRANCIS GILBERT DYETT,
to be a judicial member of the Workers Compensation Board for the period from 1 June 1981 to 10 October 1981, both dates inclusive.

And the Honourable James Halford Ramsay, Her Majesty's Minister of Labour and Industry for the State of Victoria, shall give the necessary directions therein accordingly.

TOM FORRISTAL
Clerk of the Executive Council

PUBLIC SERVICE ACT 1974

At the Executive Council Chamber, Melbourne, the twelfth day of May, 1981

PRESENT:

His Excellency the Governor of Victoria	
Mr Crozier	Mr Jona
Mr Ramsay	Mr Austin

APPOINTMENT OF DIRECTOR, MINISTRY OF EMPLOYMENT AND TRAINING

Whereas, in pursuance of the powers conferred by sections 21 and 22 of the *Public Service Act 1974*, the Ministry of Employment and Training and the office of Director, Ministry of Employment and Training, were created by Order in Council dated 5 May 1981, and published in the *Government Gazette* of 6 May 1981: Now, therefore, His Excellency the Governor of the State of Victoria, by and with the advice of the Executive Council of the said State, doth by this order appoint MICHAEL JOHN ROUX to the office of Director, Ministry of Employment and Training, at a salary of \$51 850 per annum with an allowance of \$2800 per annum as from and including 8 June 1981.

And the Honourable Brian James Dixon, Her Majesty's Minister for Employment and Training for the State of Victoria, shall give the necessary directions herein accordingly.

TOM FORRISTAL
Clerk of the Executive Council

FORESTS ACT 1958 (No. 6254)

At the Executive Council Chamber, Melbourne, the twelfth day of May, 1981

PRESENT:

His Excellency the Governor of Victoria	
Mr Crozier	Mr Jona
Mr Ramsay	Mr Austin

LANDS DEDICATED AS RESERVED FOREST

Whereas by section 48 of the *Forests Act 1958* (No. 6254), power was given to the Governor in Council to purchase any land which at any time is required by the State Forests Department for the purpose of the said Act, and by Order published in the *Government Gazette* dedicate the same as reserved forest.

And whereas in pursuance of the aforesaid power the Governor in Council has at various times purchased the lands described in Schedule No. 233 hereunder.

DEDICATION SCHEDULE No. 233

Now therefore His Excellency the Governor of the State of Victoria, by and with the advice of the Executive Council of the said State, doth by this Order dedicate the lands described in the said Schedule as reserved forest.

And the Honourable Frederick James Granter, Her Majesty's Minister of Forests for the State of Victoria, shall give the necessary directions herein accordingly.

TOM FORRISTAL
Clerk of the Executive Council

FORESTS ACT 1958

At the Executive Council Chamber, Melbourne, the
twelfth day of May, 1981

PRESENT:

His Excellency the Governor of Victoria
Mr Crozier Mr Jona
Mr Ramsay Mr Austin

DEDICATION OF AREAS OF CROWN LAND AS
RESERVED FOREST

In pursuance of the provisions of Section 45 of the
Forests Act 1958, His Excellency the Governor of the State
of Victoria, by and with the advice of the Executive
Council thereof, doth hereby order that the areas of Crown
Land described in Dedication Schedule No. 234 hereunder
be dedicated as reserved forest.

DEDICATION SCHEDULE No. 234

19 900 hectares more or less of Crown Land in the
Parishes of Arbuckle, Beloka, Buragwonduc, Cobungra,
Ensay, Guttamurra, Mowamba and Terlite-Munjie as shown
hatched on plan No. Vic. F.C.5 lodged in the Central Plan
Office.

And the Honourable Frederick James Granter, Her
Majesty's Minister of Forests for the State of Victoria, shall
give the necessary directions herein accordingly.

TOM FORRISTAL
Clerk of the Executive Council

FILMS ACT 1971

At the Executive Council Chamber, Melbourne, the
twelfth day of May, 1981

PRESENT:

His Excellency the Governor of Victoria
Mr Crozier Mr Jona
Mr Ramsay Mr Austin

EXEMPTION PURSUANT TO SECTION 11 (2)

In pursuance of the powers conferred by section 11 (2)
of the Films Act 1971 and all other powers him thereunto
enabling, His Excellency the Governor of the State of
Victoria, by and with the advice of the Executive Council
thereof, does hereby direct that the film set out in the
Schedule hereto be exempted from the provisions of
Part II. of the said Act which require application for the
registration of the film to be accompanied by the
prescribed fee.

THE SCHEDULE

The Lathe Of Heaven

And the Honourable Haddon Storey, Her Majesty's
Attorney-General for the State of Victoria shall give the
necessary directions herein accordingly.

TOM FORRISTAL
Clerk of the Executive Council

PARLIAMENTARY COMMITTEES ACT

PUBLIC BODIES REVIEW COMMITTEE

At the Executive Council Chamber, Melbourne, the
nineteenth day of May, 1981

PRESENT:

His Excellency the Governor of Victoria
Mr Crozier Mr Borthwick
Mr Lacy

NOMINATION OF PUBLIC BODIES FOR REVIEW BY
THE PUBLIC BODIES REVIEW COMMITTEE

Whereas section 48B (1) of the *Parliamentary Committees
Act 1968*, No. 9367, provides *inter alia* that the Legislative
Council or the Legislative Assembly may by resolution or
the Governor in Council may by Order published in the
Government Gazette at any time nominate a public body
for review by the Public Bodies Review Committee.

And whereas on 2 April 1980 the Legislative Assembly
resolved "That the State Rivers and Water Supply Com-
mission and each constituted water, sewerage, drainage
and river improvement trust or authority, except the Mel-
bourne and Metropolitan Board of Works, be referred to
the Public Bodies Review Committee for review".

Now therefore His Excellency the Governor of the State
of Victoria by and with the advice of the Executive Council
thereof and in exercise of the powers conferred by section
48B (1) of the *Parliamentary Committees Act 1968* doth
hereby nominate the Local Governing Bodies constituted
under the *Water Act 1958*, the Ballarat Water Commis-
sioners and Sewerage Authority, the Dandenong Valley
Authority, the First Mildura Irrigation Trust, the Geelong
Waterworks and Sewerage Trust, the La Trobe Valley
Water and Sewerage Board, the Mildura Urban Water
Trust, the West Moorabool Water Board and the personnel
of the State Rivers and Water Supply Commission, for
review by the Public Bodies Review Committee.

And the Honourable Rupert James Hamer, Her Majesty's
Premier for the State of Victoria, shall give the necessary
directions herein accordingly.

TOM FORRISTAL
Clerk of the Executive Council

LOCAL GOVERNMENT ACT 1958

At the Executive Council Chamber, Melbourne, the
nineteenth day of May, 1981

PRESENT:

His Excellency the Governor of Victoria
Mr Crozier Mr Borthwick
Mr Lacy

RE-SUBDIVISION OF THE CITY OF SUNSHINE

Pursuant to the provisions of Part II. of the *Local
Government Act 1958*, His Excellency the Governor of the
State of Victoria, by and with the advice of the Executive
Council thereof, hereby orders:—

1. that the municipal district of the City of Sunshine
shall be re-subdivided into three wards whose names and
boundaries are set forth hereunder; and

2. that for the purposes of elections of councillors this
order shall take effect on and from 20 May 1981 and for all
other purposes on and from 1 October 1981.

CITY OF SUNSHINE

RIVER WARD

(Enlarged and Re-defined)

Previous Gazette 1951.2225

Commencing at a point on the eastern boundary of the
city where it is intersected by the Melbourne and Murray
River Railway; thence westerly and north-westerly by that

railway to the S.E.C. Keilor-Brooklyn 220-kV Transmission Line; thence north-easterly by that transmission line to the junction of Main Road East with McIntyre Road being a point on the northern boundary of the city; and thence northerly, generally south-easterly and generally south-westerly by the city boundary to the point of commencement.

NORTH WARD
(Constituted)

Commencing at a point on the western boundary of the city where it is intersected by the Footscray and Bacchus Marsh Railway; thence south-easterly and easterly by that railway to a point thereon in line with the western boundary of Titles Office Lodged Plan No. 11507; thence northerly by a line, that boundary, the western boundary of Titles Office Lodged Plan No. 39984 and again the western boundary of Titles Office Lodged Plan No. 11507 to Kororoit Creek; thence north-easterly by that Creek to Esmond Street; thence northerly by Esmond Street to the Western Highway; thence south-easterly and easterly by that highway to the Melbourne and Murray River Railway; thence north-westerly by that railway to the S.E.C. Keilor-Brooklyn 220-kV Transmission Line; thence north-easterly by that transmission line to the junction of Main Road East with McIntyre Road being a point on the northern boundary of the city; and thence westerly and generally southerly by the city boundary to the point of commencement.

SOUTH WARD
(Constituted)

Commencing at a point on the western boundary of the city where it is intersected by the Footscray and Bacchus Marsh Railway; thence south-easterly and easterly by that railway to a point thereon in line with the western boundary of Titles Office Lodged Plan No. 11507; thence northerly by a line, that boundary, the western boundary of Titles Office Lodged Plan No. 39984 and again the western boundary of Titles Office Lodged Plan No. 11507 to Kororoit Creek; thence north-easterly by that creek to Esmond Street; thence northerly by Esmond Street to the Western Highway; thence south-easterly and easterly by that highway to the Melbourne and Murray River Railway; thence south-easterly and easterly by that railway to the eastern boundary of the city; and thence southerly, generally westerly and northerly by the city boundary to the point of commencement.

And the Honourable Digby Glen Crozier, Her Majesty's Minister for Local Government for the State of Victoria, shall give the necessary directions herein accordingly.

TOM FORRISTAL
Clerk of the Executive Council

LANDS DEPARTMENT
NOTICES

APPROACHING LAND SALES

Sale of Crown Land, will be held at the under-mentioned places and dates, viz.:

	No. of Gazette
Collingwood—Saturday, 13 June 1981	39
Heidelberg—Saturday, 6 June 1981	33
Lake Boga—Friday, 5 June 1981	29
Meringur—Friday, 12 June 1981	31

**PROPOSED REVOCATION OF TEMPORARY
RESERVATION OF LAND BY ORDER IN COUNCIL**

In pursuance of the provisions of section 10 of the *Crown Land (Reserves) Act 1978*, notice is hereby given that it is the intention of the Governor in Council to revoke the temporary reservation of lands by Orders in Council hereunder referred to, viz.:

SANDHURST—The temporary reservation by Order in Council of 2 July 1958 of 2023 square metres, more or less, of land in the Parish of Sandhurst (in section L) as a site for Public purposes—(Rs.7741).

NULLAWIL—The temporary reservation by Order in Council of 14 December 1896 of 20.23 hectares of land in the Parish of Nullawil (adjoining allotment 42) as a site for Water Supply purposes—(N.160⁽²⁾) (C.63824).

BURRUMBEEP—The temporary reservation by Order in Council of 16 April 1889 (see *Government Gazette* dated 18 April 1889) of 8.87 hectares of land in the Parish of BurrumbEEP (in section 13) as a site for a Quarry—(Rs.2394).

W. V. HOUGHTON
Minister of Lands

Department of Crown Lands and Survey
Melbourne, 12 May 1981

TENDERS

PUBLIC WORKS DEPARTMENT

Tenders are invited for the purposes indicated hereunder and will be received at 2 Treasury Place, Melbourne, 3002, until **TWO p.m.** on dates shown.

Tenders must be addressed to the Minister of Public Works with the envelope endorsed "Tender for

". Hand-delivered tenders must be placed in the Department's tender box in the foyer, Ground Floor, 2 Treasury Place, Melbourne.

Tenders documents are available from the Contracts Office, Room 29, 2 Treasury Place, Melbourne and where indicated, at offices of Inspectors of Works.

Tenders for works identified with star () will only be considered from Contractors qualified for repairs and painting works. Any Tenderers wishing to qualify may obtain the application form from the Contracts Office.

Tuesday, 2 June 1981

Building, Electrical and Mechanical Works

ALTONA NORTH—Part re-roofing and roof repairs, First Wing, Primary School No. 4931.

COLAC WEST—(Re-advertisement)—Toilet block—Upgrade, Primary School No. 4064. (W.O., Geelong, Camperdown.)

ECHUCA—Design, supply and installation of a fire sprinkler system, High School Gymnasium. (W.O., Shepparton, Bendigo.)

VARIOUS SITES—Supply and delivery of 74 No. Modular Buildings, F.O.G. Port Melbourne, Modular Buildings. (W.O., Geelong, Ballarat and Bendigo.)

WILLIAMSTOWN—Renewal of fire service, Technical School.

Miscellaneous

BENALLA—Maintenance cleaning—Period 1 July 1981 to 30 June 1984, Soil Conservation Authority. (W.O., Benalla.)

BOX HILL—Supply of various kitchen utensils, Technical College.

CLAYTON—Maintenance cleaning—Period 1 June 1981 to 31 May 1984, Police Station.

CLIFTON HILL—Maintenance cleaning—Period 1 July 1981 to 30 June 1984, Police Station.

ELTHAM—Maintenance cleaning—Period 15 June 1981 to 30 June 1984, Police Station, Court House and Lands Office.

HAWTHORN—Maintenance cleaning—Period 1 July 1981 to 30 June 1984, Court House.

MELBOURNE—Maintenance cleaning—Period 1 June 1981 to 31 May 1984, Public Offices, 456 Lonsdale Street.

MELBOURNE—Maintenance cleaning—Period 1 July 1981 to 30 June 1984, Head Office, 31 Queens Road.

MELBOURNE—Maintenance cleaning—Period 1 July 1981 to 30 June 1984, Childrens Court and Clinic.

MELBOURNE—Maintenance cleaning—Period 1 July 1981 to 31 May 1984, Old Treasury Building.
 MELBOURNE—Maintenance cleaning from 15 June 1981 to 30 June 1984, Coroners Court.
 MORWELL—Maintenance cleaning—Period 1 July 1981 to 30 June 1984, Court House. (W.O., Traralgon.)
 SALE—Maintenance cleaning—Period 1 July 1981 to 30 June 1984, Court House. (W.O., Traralgon.)
 STONEY POINT—Maintenance cleaning—Period 1 July 1981 to 31 May 1984, Ports and Harbors. (W.O., Stoney Point.)
 VARIOUS—Supply of bean bags for the period ending 31 August 1981, Various.

Wednesday, 10 June 1981

Building, Electrical and Mechanical Works

HAZELWOOD NORTH—Septic tank, sand filters and chlorination system, Primary School. (W.O., Traralgon.)
 ★MOOROOLBARK—(Re-advertisement)—External and minor internal renovations, Technical School.
 VARIOUS—Supply of kitchen equipment for period 1 July 1981 to 30 June 1982, Schools and other Government Departments.

VARIOUS—Supply of domestic equipment for period 1 July 1981 to 30 June 1982, Schools and other Government Departments.

WERRIBEE—Underground hydraulic services (contract 2), State Equestrian Centre. (W.O., Geelong.)

Siteworks

WANTIRNA—Non party boundary fencing, High School.
 WERRIBEE—Civil works (contract 1), State Equestrian Centre. (W.O., Geelong.)

Miscellaneous

ALEXANDRA—Maintenance cleaning—Period 1 July 1981 to 30 June 1981, Public Offices and Court House. (W.O., Alexandra.)
 MANSFIELD—Maintenance cleaning—Period 1 July 1981 to 30 June 1983, Court House. (W.O., Alexandra.)
 MELBOURNE—Removal of wreck of vessel, "Queens-cliff", Ports and Harbors, Point Cook Jetty. (Williamstown Dredging Depot.)

ALAN WOOD
 Minister of Public Works

Public Works Department
 Melbourne, 19 May 1981

**PRIVATE
 ADVERTISEMENTS**

**CITY OF BENDIGO
 LOAN No. 123**

Notice of Intention to Borrow the Sum of \$300 000 for Permanent Works and Undertakings

Notice is hereby given that the Council of the City of Bendigo proposes to borrow the principal sum of \$300 000 secured by a charge over the general rates of the Municipality, such sum to be raised by the grant of a Mortgage in accordance with the provisions of the *Local Government Act 1958*.

(a) The maximum rate of interest that may be paid is 13.9% per annum.

(b) The purpose for which the Loan is to be applied is:

	\$
Road Reconstruction	
Casley Street Reconstruction	53 940
(Bennett Street to Quick Street—Estimated Cost \$80 810)	
McDougall Road Reconstruction (Balance)	10 712

No. 42—36260/81—3

	\$
Ward Works	
Bob Street—Kerb and Channel and Foot path Construction	8 700
(Cambridge Crescent to Cahill Street—Estimated Cost \$13 165)	
McKenzie Street West—Kerb and Channel Construction	20 000
(Nursery to Bendigo Creek—Estimated Cost \$25 072)	
South Bendigo Reserve—Landscaping and seal adjacent to Progress Hall	4 500
Bendigo Sports Centre Lighting	55 000
Library Complex	
Construction of Regional Library Headquarters—Central Library—Senior Citizens and Theatre Complex—(Estimated Cost \$2 500 000)	7 643
Drainage Construction	
Ellis Street (Neale Street to Sayer Street)	13 000
Symonds Street (Balance of funds)	26 645
C.R.B. Programme	
Holdsworth Road Reconstruction—Holmes Road to Prouses Road	99 860
(Total Estimated Cost of Council Proportion of Grant and Direct Works \$128 108)	
	\$300 000

(c) The period of the Loan shall be ten (10) years.

(d) The moneys borrowed shall be repaid by the creation of a sinking fund and an appropriate amount will be set aside annually out of the Municipal Fund for such purposes as determined by the State Auditor-General.

(e) Such moneys shall be repayable at the State Insurance Office, 480 Collins Street, Melbourne.

The plans and specifications and an estimate of the cost of the proposed works and a statement showing the proposed expenditure of the money to be borrowed are open for inspection at the Municipal Offices, Lyttleton Terrace, Bendigo during office hours.

3029 C. K. BEAMISH, Town Clerk

**CITY OF CHELSEA
 LOAN No. 78**

Notice of Intention to Borrow the Sum of \$248 000 for Permanent Works and Undertakings

Notice is hereby given that the Council of the City of Chelsea proposes to borrow the principal sum of \$248 000 secured by a charge over the General Rate of the Municipality such sum to be raised by the grant of a mortgage in accordance with the provisions of the *Local Government Act 1958*.

1. The maximum rate of interest that may be paid is 13.9 per centum per annum.

2. The purposes for which the loan is to be applied are for:

	\$	\$
(a) Purchase of Land—		
1. Land Maury Road	2 000	
2. Cycle Track Access	18 000	
3. 10 Swansea Road	40 000	
	60 000	
(b) Council's share of Country Roads Board Works		38 000
(c) Council's share of construction costs Boom Barriers Argyle Avenue Rail Crossing		30 000
(d) Reserve Improvements—Bonbeach Reserve Watering System		40 000
(e) Purchase of Plant and Equipment		80 000
		248 000

3. The period of the loan shall be ten (10) years.

4. The moneys borrowed shall be repayable by providing out of the municipal fund equal half-yearly instalments of \$23 318.55 each including principal and interest on 1 January and 1 July during the currency of the loan. The first instalment shall be repayable on 1 January 1982.

5. Such moneys shall be repayable to the Bank of New South Wales, 454 Nepean Highway, Chelsea.

The plans and specifications and estimates of the costs of the proposed works and a statement showing the proposed expenditure of the moneys to be borrowed are open for inspection at the Offices of the Council of the City of Chelsea, 317 Station Street, Chelsea, 3196.

Dated 18 May 1981

3028

J. J. DRINAN, Town Clerk

CITY OF FOOTSCRAY

LOAN No. 162

(Replaces cancelled Loan No. 161)

Notice of Intention to Borrow the Sum of \$300 000 for Permanent Works and Undertakings

Notice is hereby given that the Council of the City of Footscray proposes to borrow the sum of Three hundred thousand dollars (\$300 000) secured by a charge over the general rates of the municipality, such sum to be raised by the grant of a mortgage in accordance with the provisions of the *Local Government Act 1958*.

1. The maximum rate of interest that may be paid is 13.9 per centum per annum.

2. The period of the loan shall be fifteen years.

3. The loan is to be liquidated by providing out of the municipal fund thirty equal consecutive half-yearly instalments of \$24 054.61 including principal and interest, payable on 1 January and 1 July in each year during the currency of the loan. The first instalment shall be payable on 1 January 1982.

4. Such moneys shall be payable at the office of the Local Authorities Superannuation Board, Rigby House, 15 Queens Road, Melbourne 3004.

5. The purposes for which the loan is to be applied are:—

Contributions to Country Roads Board Works	100 000
Electricity Supply Department—various equipment	75 000
Purchase of properties—Footscray Business District Distributor Road	100 000
Roads and Streets—construction and reconstruction	25 000
	<u>300 000</u>

The plans and specifications, the estimate of the cost of the proposed works and a statement showing the proposed expenditure of the moneys to be borrowed, are open for inspection at the Town Hall, Footscray.

Dated at Footscray, 12 May 1981

2902

B. J. WARD, Town Clerk

Town and Country Planning Act 1961

CITY OF HORSHAM PLANNING SCHEME

NOTICE THAT A PLANNING SCHEME HAS BEEN PREPARED AND IS AVAILABLE FOR INSPECTION

Amendment No. 63, 1980

Notice is hereby given that the Council of the City of Horsham, pursuant of its powers under the *Town and Country Planning Act 1961* has prepared a planning scheme for the purpose of amending Column 4 of the Table to Clause 6 in Residential "A" zones by the addition of the following:—

"Restaurant" on a site having one of its boundaries on alignment to the Western Highway.

A copy of the scheme has been deposited at the Office of the Council of the City of Horsham, Civic Centre, Urquhart Street, Horsham, and at the Department of Planning, 235 Queen Street, Melbourne, and will be open for inspection during office hours by any person free of charge. Any persons affected by the scheme are required to set forth in writing any submissions they wish to make with respect to the scheme, addressed to the Town Clerk, City of Horsham, Post Office Box 511, Horsham, by 20 June 1981, and to state whether they wish to be heard in respect of their submission.

2905

A. R. CONN, Town Clerk

CITY OF SHEPPARTON

LOAN No. 114

Notice of Intention to Borrow the Sum of \$8000 for Permanent Works and Undertakings

Notice is hereby given that the Council of the City of Shepparton proposes to borrow the sum of \$8000 secured by a charge over the general rates of the municipality, such sum to be raised by the grant of a mortgage in accordance with the provisions of the *Local Government Act 1958*.

1. The Principal amount to be borrowed is \$8000.

2. The maximum rate of interest to be paid is 13.7 per centum per annum.

3. The times at which the moneys borrowed are to be repayable are 26 December and 26 June during the years 1981 to 1986.

4. The moneys shall be repayable to the Commonwealth Savings Bank of Australia, Melbourne.

5. The purposes for which the loan is to be applied are—

(i) Furnishing of recreation room at Victoria Lake Caravan Park	1900
(ii) Upgrading of pressurised watering system at John McEwen Reserve (part cost)	6100
	<u>8000</u>

6. The loan shall be liquidated by the provision, out of the Municipal Fund, of ten equal half-yearly instalments of \$1131.14. The first instalment shall be payable on 26 December 1981, and the final instalment on 26 June 1986.

7. The plans, specifications and estimate of the cost of the proposed works and a statement showing the proposed expenditure of the moneys to be borrowed, are open for inspection at the office of the Council of the City of Shepparton, Civic Centre, Welsford Street, Shepparton.

3065

I. L. GILBERT, Town Clerk

CITY OF SHEPPARTON

LOAN No. 113

Notice of Intention to Borrow the Sum of \$210 500 for Permanent Works and Undertakings

Notice is hereby given that the Council of the City of Shepparton proposes to borrow the sum of \$210 500 secured by a charge over the general rates of the municipality, such sum to be raised by the grant of a mortgage in accordance with the provisions of the *Local Government Act 1958*.

1. The principal amount to be borrowed is \$210 500.

2. The maximum rate of interest that may be paid is 13.9 per cent per annum.

3. The times and place at which the moneys borrowed are to be repayable are 26 December and 26 June, during the years 1981 to 1991. Such moneys shall be repayable to the Commonwealth Savings Bank of Australia, Melbourne.

4. The purpose for which the loan is to be applied are—

Construction of a drainage retardation basin to enable development of the South-eastern portion of the municipality—part cost	140 000
Extensions to the Shepparton-United Football Clubrooms at the Deakin Reserve	20 000
Development of stage one and provision of services to the Council's Industrial Estate in Hawkins Street, Shepparton	50 500

5. The loan shall be liquidated by the provision out of the municipal fund of nineteen instalments of \$16 878.31 with a final instalment of \$135 699.25; the first instalment shall be payable on 26 December 1981, and the final instalment of \$135 699.25 on 26 June 1991.

6. The plans and specifications and the estimate of cost of the proposed works and a statement showing the proposed expenditure of the moneys to be borrowed are open for inspection at the office of the Council of the City of Shepparton, Civic Centre, Welsford Street, Shepparton.

3066

I. L. GILBERT, Town Clerk

CITY OF SHEPPARTON

LOAN No. 112

Notice of Intention to Borrow the Sum of \$25 000 for Permanent Works and Undertakings

Notice is hereby given that the Council of the City of Shepparton proposes to borrow the sum of \$25 000, secured by a charge over the general rates of the municipality, such sum to be raised by the grant of a mortgage in accordance with the provisions of the *Local Government Act 1958*.

1. The Principal amount to be borrowed is \$25 000.
2. The maximum rate of interest to be paid is 13.9 per centum per annum.
3. The times at which the moneys borrowed are to be repayable are 26 December and 26 June during the years 1981 to 1991.
4. The moneys shall be repayable to the Commonwealth Savings Bank of Australia, Melbourne.
5. The purpose for which the loan shall be applied is to partially finance the cost of upgrading the Raymond West Swimming Pool. The facilities to be provided in the projected upgrading programme include:
 - (a) Construction of new 8 lane 50m chlorinated and filtered Olympic Pool;
 - (b) Installation of filtration system for leisure pool;
 - (c) Fencing of entire area known as the "Raymond West Swimming Pool";
 - (d) Construction of new Amenities Block, Administration and First Aid Rooms and Kiosk;
 - (e) Relocation of Swimming Clubrooms;
 - (f) Provision of Life Saving Clubrooms—Council contribution (a contribution will be made by the Shepparton Life Saving Club);
 - (g) Resurfacing of floor of leisure pool;
 - (h) Lighting;
 - (i) Ancilliary works.

The estimated cost of the project is \$760 000.

6. The loan shall be liquidated by the provision, out of the Municipal Fund, of nineteen half-yearly instalments of \$2004.55 and a final instalment of \$16 116.28 including principal and interest. The first instalment shall be payable on 26 December 1981, and the final instalment on 26 June 1991.

7. The plans, specifications and estimate of the cost of the proposed work, and a statement showing the proposed expenditure of the moneys to be borrowed, are open for inspection at the office of the Council, Civic Centre, Welford Street, Shepparton, during office hours.

3067

I. L. GILBERT, Town Clerk

CITY OF SUNSHINE

LOAN No. 156

Notice of Intention to Borrow the Sum of \$50 000 for Permanent Works and Undertakings

Notice is hereby given that the Council of the City of Sunshine proposes to borrow the principal sum of \$50 000 secured by a charge over the general rates of the municipality, such sum to be raised by the grant of a mortgage in accordance with the provisions of the *Local Government Act 1958*.

1. The maximum rate of interest that may be paid is 13.9% per annum.
2. The purpose for which the loan is required is as follows:—

Construction of Municipal Office Extensions
(Part) \$50 000

Total estimated cost now \$1 250 000 of which
\$1 100 000 has been previously borrowed.

3. The period of the loan shall be fifteen (15) years.
4. The loan will be redeemed by thirty (30) equal amounts of principal and interest payable half yearly. The first payment will be made on 1 January 1982.
5. Payments will be made at the office of the National Bank of Australasia Limited, 500 Bourke Street, Melbourne, or such other place or places as the Bank from time to time may require.

The plans and specifications and the estimate of the proposed work and a statement showing the proposed expenditure of the money to be borrowed are open for inspection at the office of the Council of the City of Sunshine at the Municipal Offices, Alexandra Avenue, Sunshine.

2964

T. W. DEUTSCHMANN, Town Clerk

CITY OF TRARALGON

LOAN No. 83

Notice of Intention to Borrow

Notice is hereby given that the Council of the City of Traralgon intends to borrow Two hundred thousand dollars (\$200 000) secured by a charge over the General Rates of the Municipality by the grant of a Mortgage in accordance with the provisions of the *Local Government Act*.

In connection herewith the following information is stated:

- (a) The amount of the principal moneys to be borrowed is Two hundred thousand dollars (\$200 000).
- (b) The maximum rate of interest to be paid is 13.9 per centum per annum.
- (c) The period of the loan shall be fifteen (15) years.
- (d) The money borrowed shall be repayable by thirty (30) equal instalments of \$16 036.41 including principal and interest payable on 1 January and July. The first instalment shall be payable on 1 January 1982 and the final instalment shall be payable on 1 July 1996. Such moneys shall be repayable at the Local Authorities Superannuation Board, 15 Queens Road, Melbourne.
- (e) The purpose for which the loan is to be applied is the development of the Catterick Crescent Reserve Sporting Complex.

The plans and specifications and the estimate of the cost of the proposed works and a statement showing the proposed expenditure of moneys to be borrowed are open for inspection at the office of the Council of the City of Traralgon, Kay Street, Traralgon.

2901

K. J. SAUNDERS, Town Clerk

BOROUGH OF PORT FAIRY—PORT FAIRY PLANNING SCHEME 1959

NOTICE THAT A PLANNING SCHEME HAS BEEN PREPARED AND IS AVAILABLE FOR INSPECTION

Amendment No. 11, 1981

Notice is hereby given that the Council of the Borough of Port Fairy in pursuance of its powers under the *Town and Country Planning Act 1961* has prepared a planning scheme for the area on the north side of Regent Street Port Fairy commencing 483.6 m west from the Princes Highway and bounded on the west and north by the land reserved for a new by-pass road and the Reedy drain respectively. The purpose of the scheme is to rezone the said land from Agricultural to Residential.

A copy of the scheme has been deposited at the Borough Chambers, Bank Street Port Fairy and at the office of the Department of Planning, 235 Queen Street Melbourne, and will be open for inspection during office hours by any person free of charge.

Any persons affected by the scheme are required to set forth in writing any submissions they may wish to make with respect to the scheme addressed to the Town Clerk, Borough of Port Fairy, P.O. Box 51 Port Fairy 3284 by 22 June 1981 and to state whether they wish to be heard in respect of their submissions.

Dated 20 May 1981

2969

IAN C. PATIENCE, Town Clerk

SHIRE OF ALEXANDRA

LOAN No. 47

Notice of Intention to Borrow the Sum of \$60 000 for Permanent Works and Undertakings

Notice is hereby given that the Council of the Shire of Alexandra proposes to borrow the principal sum of Sixty thousand dollars (\$60 000) secured by a charge over the general rates of the municipality, such sum to be raised by the grant of a mortgage in accordance with the provisions of the *Local Government Act 1958*.

1. The maximum rate of interest that may be paid is 13.9 per centum per annum.
2. The purpose for which the loan is to be applied:
Assistance to Decentralized Industries \$60 000
3. The period of the loan shall be 15 years.
4. The moneys shall be repayable by half-yearly instalments of approximately \$4810.92 including principal and interest on 1 February and 1 August during the currency of the loan. The first instalment shall be repayable on 1 February 1982.
5. Such moneys shall be repayable at the National Bank of Australasia—Alexandra.

The plans and specifications and the estimate of the cost of the proposed works and a statement showing the proposed expenditure of the moneys to be borrowed are open for inspection at the Shire Offices, Perkins Street Alexandra.

3030 G. I. WALSHE, Shire Secretary

SHIRE OF ARARAT WATERWORKS TRUST

STREATHAM URBAN DISTRICT

Notice to Owners of Tenements in the Undermentioned Streets and Private Streets, Lanes, Courts and Alleys Opening Thereto

Rossbridge—Streatham Road

Commencing at Crown Allotment 13, Township of Streatham thence north westerly to Crown Allotment 1, Section 5, Parish of Tara.

Boundary Road

Commencing at Crown Allotment 13, thence northerly to Crown Allotment 40e, Township of Streatham.

The main pipes in the said streets being laid down the owners of all tenements situated as above are hereby required on or before 20 June 1981, to cause a proper pipe and stopcocks to be laid so as to supply water within such tenements from the main pipe.

2972 L. M. CONSTABLE, Secretary

SHIRE OF AVON

LOAN No. 22

Notice of Intention to Borrow the Sum of \$100 000 for Permanent Works and Undertakings

Notice is hereby given that the Council of the Shire of Avon proposes to borrow the principal sum of \$100 000, secured by a charge over the general rates of the Municipality, such sum to be raised by the grant of a mortgage in accordance with the provisions of the *Local Government Act 1958*.

(1) The maximum rate of interest that may be paid is 13.9 per cent per annum.

(2) The purpose for which the Loan is to be applied is:
Purchase of Plant—Part Cost.

(3) The period of the loan shall be ten (10) years.

(4) The moneys borrowed shall be repayable by providing out of the municipal fund, half-yearly instalments of approximately \$9402.64 each, including principal and interest, on 8 March and 8 September, during the currency of the loan. The first instalment shall be payable on 8 March 1982.

(5) Such moneys shall be payable to the National Bank of Australasia Ltd., Melbourne, or such other place as the Bank may direct.

The plans and specifications and the estimate of the cost of the proposed works and a statement showing the proposed expenditure of the moneys to be borrowed are open for inspection at the Office of the Council of the Shire of Avon, Tyers Street, Stratford.

2903 G. W. BRAYSHAW, Shire Secretary

Local Government Act

SHIRE OF FLINDERS

NOTICE OF INTENTION TO TAKE LAND COMPULSORILY

Whereas the Council of the Shire of Flinders deems it expedient to exercise its power of taking compulsorily the land being lots 47, 49 & 50 block J and lots 53, 54, 55 & 56 block I on lodged plan No. 5108 Parish of Wannaeue and being part of the land described in certificate of title volume 3406 folio 016 which said land is required by the

Council for opening new streets and whereas the Council has caused to be prepared a map and other papers setting out the general description of the work or undertaking for which the land proposed to be taken is to be used the description of the land proposed to be taken and the names of the owners or reputed owners lessees or reputed lessees mortgagees and occupiers of that land so far as those names are known to or can be ascertained by the Council and whereas the said map and other papers are deposited at the Office of the said Council at Rosebud and are and shall be open for inspection by all persons interested at all reasonable hours for the space of forty (40) clear days after the publication of this notice in the *Government Gazette*.

Notice is hereby given to all persons affected by the proposed taking of the said land to set forth in writing addressed to the Council or Shire Secretary within forty (40) clear days of the publication of this notice in the *Government Gazette* all objections which they may have to the taking of the said land.

Dated 6 May 1981

2941

G. W. WHITE, Shire Secretary

Town and Country Planning Act 1961 (Twelfth Schedule)

SHIRE OF KILMORE PLANNING SCHEME 1973

NOTICE THAT A PLANNING SCHEME HAS BEEN PREPARED AND IS AVAILABLE FOR INSPECTION

Amendment No. 48, 1981

Notice is hereby given in accordance with the *Town and Country Planning Act 1961* that a Planning Scheme has been prepared for Crown Allotment 8A, Section 38, Parish of Bylands, known as 18 Powlett Street, Kilmore and contained in Volume 9344, Folio 146. The purpose of the Scheme is to rezone this land to "Commercial". A copy has been deposited at the Civic Centre, Sydney Street, Kilmore and at the Office of the Department of Planning, 500 Collins Street, Melbourne and may be inspected during office hours by any person free of charge.

Any objections to the Scheme should be sent in writing to the Shire Secretary, Shire of Kilmore, Civic Centre, Sydney Street, Kilmore, on or before 20 June 1981, for consideration by the Responsible Authority.

Dated 20 May 1981

3027

JIM ELVEY, Shire Secretary

Town and Country Planning Act 1961 (Twelfth Schedule)

SHIRE OF MANSFIELD—EILDON RESERVOIR PLANNING SCHEME 1959

NOTICE THAT A PLANNING SCHEME HAS BEEN PREPARED AND IS AVAILABLE FOR INSPECTION

Notice is hereby given that the Council of the Shire of Mansfield in pursuance of its powers under the *Town and Country Planning Act 1961* has prepared a planning scheme to rezone approximately 2.4 ha. of land from 'Rural' to 'Residential'. The area affected is all that piece of land, being C.A. 1, Sec. 7, C.A. 6A, Sec. 9, and Pt. C.As 1B, 1c, 2b, 2c, 3b, 3c, 4b, 4c, 5b, 5c, 6b, 6c and 7, Sec. 7, Township of Bonnie Doon; and Pt. C.As 6, 9 and 10, Sec. 9, Parish of Brankeet.

A copy of the scheme has been deposited at the offices of the Council of the Shire of Mansfield, 33 Highett Street, Mansfield, and at the offices of the Town and Country Planning Board, 235 Queen Street, Melbourne, and will be open for inspection during office hours by any person free of charge.

Any persons affected by the scheme are required to set forth in writing any submissions they may wish to make with respect to the scheme, addressed to the Shire Secretary, Shire of Mansfield, 33 Highett Street, Mansfield, 3722, by 24 August 1981, and to state whether they wish to be heard in respect of their submissions.

15 May 1981

2943

F. WALSHE, Shire Secretary

SHIRE OF MELTON

LOAN No. 109

Notice of Special Order

The following resolution was passed by the Council on 23 February 1981 and confirmed at a meeting of the Council held on 30 March 1981:

That the Council does by Special Order, hereby resolve to borrow the sum of One Hundred Thousand Dollars (\$100 000) secured by a charge over the general rates of the Municipality such sum to be raised by the grant of a mortgage in accordance with the provisions of the *Local Government Act 1958* and in connection therewith the following is specified:

- (i) The amount of the principal moneys which it is proposed to borrow is One Hundred Thousand Dollars.
- (ii) The rate of interest to be paid is 13.9 per centum per annum.
- (iii) The purpose for which the loan is to be applied is for liquidating part of the advances obtained from the National Bank of Australasia Limited, Melton, by overdraft of current account for the execution of schemes for the construction of private streets and drains.
- (iv) The period of the loan shall be 15 years.
- (v) The moneys borrowed shall be repayable by 30 equal half-yearly instalments of \$8018.21 including principal and interest on 1 April and 1 October during the currency of the loan. The first instalment shall be payable on 1 October 1981.
- (vi) The loan shall be liquidated from the receipts of money payable under the private street and drainage schemes.
- (vii) Such moneys shall be repayable to the Local Authorities Superannuation Board, 15 Queens Road, Melbourne, 3004.

2944 M. B. WATSON
Shire Secretary and Chief Executive Officer

- (vii) Such moneys shall be repayable to the Local Authorities Superannuation Board, 15 Queens Road, Melbourne, 3004.

M. B. WATSON, Shire Secretary and Chief Executive Officer 2945

SHIRE OF NARRACAN

LOAN No. 68

SPECIAL ORDER

Private Streets Construction

Notice is hereby given that the Council of the Shire of Narracan at a meeting held on 18 May 1981, confirmed the following Special Order:

That the Council of the Shire of Narracan does by Special Order hereby resolve to borrow the principal sum of \$198 000 secured by a charge over the General Rates of the Municipality, such sum to be raised by the grant of a mortgage in accordance with the provisions of section 585 of the *Local Government Act* as amended.

1. The maximum rate of interest to be paid shall be 13.9% per annum.
2. The period of the loan shall be fifteen (15) years.
3. The moneys borrowed shall be repayable by 30 half-yearly instalments of \$15 876.05 each, including principal and interest on 1 June and 1 December, during the currency of the loan, the first instalment being payable on 1 December 1981.
4. Such moneys shall be repayable to the Local Authorities Superannuation Board, "Rigby House", 15 Queens Road, Melbourne, or such other place or places as the Board from time to time may require.
5. The loan is to be applied to Private Street Construction Schemes:

	\$
(a) Centenary Drive, Trafalgar	82 000
(b) Edward Crescent and Rose Court, Trafalgar	116 000
	198 000

6. The loan is to be liquidated from the principal and interest repayments of the private street instalment contributors.

2956 W. F. NELSON, Shire Secretary

SHIRE OF MELTON

LOAN No. 110

Notice of Special Order

The following resolution was passed by the Council on 30 March 1981 and confirmed at a meeting of the Council held on 11 May 1981:

That the Council does by Special Order, hereby resolve to borrow the sum of Four hundred and thirty-seven thousand dollars (\$437 000) secured by a charge over the general rates of the Municipality such sum to be raised by the grant of a mortgage in accordance with the provisions of the *Local Government Act 1958* and in connection therewith the following is specified:

- (i) The amount of the principal moneys which it is proposed to borrow is Four hundred and thirty-seven thousand dollars;
- (ii) The rate of interest to be paid is 13.9 per centum per annum;
- (iii) The purpose for which the loan is to be applied is for liquidating part of the advances obtained from The National Bank of Australasia Limited, Melton, by overdraft of current account for the execution of schemes for the construction of private streets and drains;
- (iv) The period of the loan shall be 15 years;
- (v) The moneys borrowed shall be repayable by 30 equal half-yearly instalments of \$35 039.55 each including principal and interest on 1 June and 1 December during the currency of the loan. The first instalment shall be payable on 1 December 1981.
- (vi) The loan shall be liquidated from the receipts of money payable under the private street and drainage schemes.

Town and Country Planning Act 1961 (Twelfth Schedule)

SHIRE OF NEWHAM AND WOODEND—SHIRE OF NEWHAM AND WOODEND PLANNING SCHEME

NOTICE THAT A PLANNING SCHEME AMENDMENT HAS BEEN PREPARED AND IS AVAILABLE FOR INSPECTION

Amendment No. 13

Notice is hereby given that the Shire of Newham and Woodend in pursuance of its powers under the *Town and Country Planning Act 1961*, has prepared an Amendment to the Shire of Newham and Woodend Planning Scheme for the areas and purposes specified hereunder:

Quarry Reserve—Blackmore Road, Parish of Woodend.

A copy of the said Amendment and an accompanying Explanatory Report have been deposited at the Municipal Offices, 92 High Street, Woodend, 3442, and at the office of the Department of Planning, 235 Queen Street, Melbourne, 3000, and will be available for inspection during office hours by any person free of charge. Copies of both the Amendment and the Explanatory Report may be purchased from the Municipal Office at a cost of \$2.00.

Any persons affected by the Amendment are required to set forth in writing all objections they may have, addressed to The Shire Secretary, Shire of Newham and Woodend, 92 High Street, Woodend, 3442, on or before 20 August 1981, and to state whether they wish to be heard formally in respect of their objections.

(Forms on which objections may be written can be obtained from the above places.)

2910 J. W. CHANDLER, Shire Secretary

Town and Country Planning Act 1961 (Twelfth Schedule)
SHIRE OF NEWHAM AND WOODEND PLANNING
SCHEME

NOTICE THAT A PLANNING SCHEME HAS BEEN PREPARED AND IS AVAILABLE FOR INSPECTION

Amendment No. 14

Notice is hereby given that the Shire of Newham and Woodend in pursuance of its powers under the *Town and Country Planning Act 1961*, has prepared an Amendment to the Shire of Newham and Woodend Planning Scheme for the areas and purposes specified hereunder:

Quarry Reserve—Crown Land at rear of Carlsruhe Cemetery, Parish of Woodend.

A copy of the said Amendment and an accompanying Explanatory Report have been deposited at the Municipal Offices, 92 High Street, Woodend, 3442, and at the office of the Department of Planning, 235 Queen Street, Melbourne, 3000, and will be available for inspection during office hours by any person free of charge. Copies of both the Amendment and the Explanatory Report may be purchased from the Municipal Office at a cost of \$2.00.

Any persons affected by the Amendment are required to set forth in writing all objections they may have, addressed to the Shire Secretary, Shire of Newham and Woodend, 92 High Street, Woodend, 3442, on or before 20 August 1981, and to state whether they wish to be heard formally in respect of their objections.

(Forms on which objections may be written can be obtained from the above places.)

3031 J. W. CHANDLER, Shire Secretary

SHIRE OF PAKENHAM

LOAN No. 95

Notice of Intention to Borrow the Sum of \$343 000 for Permanent Works and Undertakings

Notice is hereby given that the Council of the Shire of Pakenham proposes to borrow the principal sum of \$343 000 (Three hundred and forty-three thousand dollars) secured by a charge over the general rates of the municipality, such sum to be raised by the grant of a Mortgage in accordance with the provisions of the *Local Government Act 1958*.

1. The maximum rate of interest that may be paid is 13.9 per centum per annum.

2. The purpose for which the loan is to be applied is:

	\$
South Side Car Park (part)	229 670
Land acquisition and provision of services to Civic Centre Site	90 000
Beaconsfield Infant Welfare Centre—Extension to provide additional infant welfare facilities	5 330
Beaconsfield Upper School Reserve—Construction of Netball Court	1 500
Beaconsfield Scout Hall Extensions	1 500
Playground development—Robin and Finch Courts, Pakenham	5 000
Garfield Recreation Reserve Drainage Works	10 000
	343 000

3. The period of the loan shall be fifteen (15) years.

4. The monies borrowed shall be repayable by providing out of the Municipal Fund thirty (30) half yearly instalments of \$27 502.44 each, including principal and interest, on 1 June and 1 December during the currency of the loan. The first instalment shall be payable on 1 December 1981.

5. Such monies shall be repayable to the Local Authorities Superannuation Board, 15 Queens Road, Melbourne, 3004.

The Plans and Specifications and the estimate of the cost of the proposed work and a Statement showing the proposed expenditure of the monies to be borrowed are open for inspection at the Office of the Council of the Shire of Pakenham, Main Street, Pakenham, during office hours.

2942 B. J. WALLIS, Shire Secretary

Town and Country Planning Act 1961

SHIRE OF SOUTH GIPPSLAND PLANNING SCHEME

NOTICE THAT A PLANNING SCHEME HAS BEEN PREPARED AND IS AVAILABLE FOR INSPECTION

Amendment No. 47, 1980

Notice is hereby given that the Shire of South Gippsland in pursuance of its powers under the *Town and Country Planning Act 1961*, has prepared a planning scheme for all of that land zoned Rural in the Shire of South Gippsland Planning Scheme area.

A copy of the scheme has been deposited at the Shire Office, 14-18 Pioneer Street, Foster 3960, and at the office of the Department of Planning, Victoria, 235 Queen Street, Melbourne, and will be open for inspection during office hours by any person free of charge.

Any persons affected by the scheme are required to set forth in writing any submissions they may wish to make with respect to the scheme, addressed to the Shire Secretary, P.O. Box 104, Foster 3960, by 20 June 1981, and to state whether they wish to be heard in respect of their submissions.

Dated 14 May 1981

3026

H. R. LOMAX, Shire Secretary

SHIRE OF TALBOT AND CLUNES

LOAN No. 20

Notice of Intention to Borrow the Sum of \$20 000 for Permanent Works and Undertakings

Notice is hereby given that the Council of the Shire of Talbot and Clunes, proposes to borrow the principal sum of \$85 000, secured by a charge over the general rates of the Municipality, such sum to be raised by the grant of a mortgage in accordance with the provisions of the *Local Government Act 1958*.

1. The maximum rate of interest that may be paid is 13.9 per cent per annum.

2. The purpose for which the loan is to be applied is:
Purchase of Road Making Plant—Grader.

3. The period of the Loan shall be 10 years.

4. The moneys borrowed shall be repayable by providing out of the municipal fund, half-yearly instalments of approximately \$792.25, each including principal and interest, on 1 January and 1 July, during the currency of the loan. The first instalment shall be payable on 1 January 1982.

5. Such moneys shall be repayable to the A.N.Z. Savings Bank Limited, at the Office of the said Bank, Fraser Street, Clunes.

The plans and specifications and the estimate of the cost of the proposed works and a statement showing the proposed expenditure of the moneys to be borrowed are open for inspection at the Office of the Council of the Shire of Talbot and Clunes, Shire Offices, Talbot.

13 May 1981

2970

R. J. PRYOR, Shire Secretary

Town and Country Planning Act 1961 (Twelfth Schedule)

WARRAGUL PLANNING SCHEME 1954

NOTICE THAT A PLANNING SCHEME HAS BEEN PREPARED AND IS AVAILABLE FOR INSPECTION

Amendment No. 39, 1980

Notice is hereby given that the Shire of Warragul in pursuance of its powers under the *Town and Country Planning Act 1961* has prepared a planning scheme to permit the establishment of a Motel within the Light Industrial Zone and an Indoor Sports Centre within the Heavy Industrial Zone.

A copy of the scheme has been deposited at the Shire Office, Warragul; the office of the Department of Planning, 235 Queen Street, Melbourne and the Office of the Department of Planning, Central Gippsland Office, 71 Hotham Street, Traralgon, and will be open for inspection during office hours by any person free of charge.

Any person affected by the scheme are required to set forth in writing any submissions they may wish with respect to the scheme, addressed to the Shire Secretary, Shire of Warragul by 20 June 1981 and to state whether they wish to be heard in respect of their submissions.

11 May 1981

2940 V. B. DAVIDSON, Shire Secretary

SHIRE OF WERRIBEE

By-Law No. 69

By-Laws Repealing By-Law

In pursuance of the powers conferred by the Local Government Act 1958, the Health Act 1958, the Petrol Pumps Act 1958 and in pursuance of all other powers it thereunto enabling the Shire President, Councillors and Citizens of the Shire of Werribee orders as follows:

Short Title

1. This By-Law is the By-Laws Repealing By-Law.

Commencement and Area of Operation

2. The By-Law operates—

(a) from the day after—

(i) this By-Law; or

(ii) notice of its making; is published in the Government Gazette;

(b) throughout the Shire of Werribee.

Repeal of Existing By-Laws

3. (a) The following By-Laws of the Shire of Werribee ARE NOT repealed—

No.	Title
57	Blasting Operations By-Law
58	Mobile Crane By-Law
59	Street Reserves and Bus Shelters Protection By-Law
60	Refuse Receptacles By-Law
61	Street Collectors By-Law
62	Camping and Caravan By-Law
63	Motorised Vehicles for Recreational Purposes By-Law
64	Irrigation Waters By-Law
65	Building Regulations
66	Control of Council Reserves
67	Control of Swimming Pools
68	Meeting Procedure By-Law
(b) Save as aforesaid all By-Laws of—	
The Council of the Municipality of the Shire of Werribee, the name of such municipality having been changed from the Shire of Wyndham on 15 December 1909, are repealed to the extent to which they are at present in force within the municipal district of the Council of the Shire of Werribee.	
(c) Without prejudice to the generality of this clause all By-Laws in the Schedule to this By-Law being By-Laws of the Shire of Wyndham or the Shire of Werribee are repealed.	

SCHEDULE

No.	Title	Gazetted
1	Miscellaneous—Part IX 15 Schedule	
2	Regulation of Proceedings of Council, &c. Part XI 15 Schedule	
3	Police Offences Statute 1865—First Part	18. 2.1881
1	Depositing of night soil, &c.—repealed by No. 4	7. 6.1881
3	15th Schedule, Parts 1, 2, 4, 5, 7 and 8	16.12.1892
4	Night soil, &c. (repealing No. 71)	
4	15th Schedule, Parts 1 and 2	
5	Offensive Matter drainage into Werribee River	
5	Subdivisions and Private Streets	
6	Tractions, Locomotive or Roller Engines (Travelling)	
6	Registration of Dairies, &c.	
6	Fees—Weights and Measures	
7	Garbage and refuse receptacles—repealed by No. 50	
7	Obstructing use of Carriageway, &c. in Werribee	15. 4.1898
8	Driving of Traction Engines through Werribee	

No.	Title	Gazetted
9	Writing, painting, &c. on footpaths	
10	Regulating and restraining the erection of removed wooden buildings	
11	Markets (extinct)	
11	Diverting water onto roads	
12	Regulating and restraining the erection and construction of structures/hoardings—repealed by No. 34	12. 8.1919
13	Miscellaneous Matters—Part IX, 15 Schedule	3.11.1920
14	Suppressing Nuisances and for preventing Fires	
15	Collection of Refuse (Altona)	
16	Registration of Premises—Repealed by No. 27	11. 3.1924
17	Sale of Foodstuffs, Flowers and Licensing of Hawkers (Altona)	24. 7.1928
18	Sale of Foodstuffs, Flowers and Licensing of Hawkers—repealed by No. 49	24. 7.1928
19	Regulating and restraining the erection and construction of buildings	25. 6.1930
20	Collection of Refuse (Altona)	
21	Petrol Pumps	28. 1.1930
22	Supply and Distribution of Water with Board of Works (Altona) Repealed by No. 30	
23	Residential Areas (Altona)	
24	Regulating of Traffic	
25	Amending No. 22	
26	Grazing of Cattle (Altona)	19. 6.1935
27	Registration of Premises—repealing No. 16	25.11.1936
28	Amending Part 1 By-Law 19 (Altona)	22. 2.1939
29	Depositing of Refuse	13. 4.1939
30	Supply and Distribution of Water with Board of Works—repealing No. 22	
31	Care, Protection and Management—Altona Park (Altona)	21.10.1941
32	Regulating of Fowl Houses and Yards—repealed by No. 51	2.12.1942
33	Amending No. 12 (Altona)	30.12.1942
34	Amending No. 11 and repealing No. 12	15. 3.1944
35	Regulating Traffic	28. 5.1952
36	Repealing No. 23 (Altona)	26. 2.1947
37	Regulating and Controlling excavating operations (Altona)	10. 2.1947
38	Uniform Building Regulations (Altona)	
39	Uniform Building Regulations (Werribee)	
40	Residential Areas—Werribee	
41	Buildings	
42	Registration of Premises	
43	Health Regulations	
44	Supply and Distribution of Water with Board of Works	10. 7.1956
45	Roads of Limited Access	22. 3.1961
46	Regulating Management and use of Werribee Baths	28.11.1961
47	Werribee South Recreation Reserve	
48	Street Hawkers	
49	Street Hawkers—repealing No. 18	1. 4.1964
50	Refuse—repealing No. 7	27. 7.1965
51	Poultry—repealing No. 32	6. 7.1965
52	Registration of Premises—repealed by No. 54	1. 6.1966
53	Septic Tank Fees	15. 2.1967
54	Registration of Premises—repealing No. 52	3. 4.1968
55	Meat Inspection Fees	
56	Animal By-Law	

Resolution for passing this By-Law agreed to by the Council of the Shire of Werribee on 28 November 1977 and confirmed on 27 February 1978.

The corporate seal of the President, Councillors and Ratepayers of the Shire of Werribee was hereunto affixed, in the presence of—

(SEAL) S. D. SOUTHWICK, President
M. J. BLOXHAM, Councillor
J. T. KERR, Shire Secretary

Approved by the Governor in Council, 22 January 1980
—TOM FORRISTAL, Clerk of the Executive Council 2906

SHIRE OF WERRIBEE

By-Law No. 75

Poultry By-Law

A By-Law of the Shire of Werribee made under section 93 (j) of the Health Act 1958 for the purpose of regulating the keeping of poultry and the regulating or prohibiting of the keeping of any place or the storage of any things which in the opinion of the Council may be offensive, injurious to health or dangerous and under section 197 (1) (xxxi) of the Local Government Act 1958 for the purpose of regulating the keeping of birds with power to limit the number and kind of birds kept on any property within any area within the municipal district set forth in this By-Law and declared herein to be a residential area.

In pursuance of the powers conferred by the Health Act 1958 and of any and every other power it thereunto enabling the President, Councillors and Ratepayers of the Shire of Werribee orders as follows:

PART I

Introduction

1. This By-Law shall be known as the Poultry By-Law;
2. This By-Law shall apply and have operation throughout the whole of the municipal district.
3. In this By-Law unless inconsistent with the context or subject matter:

"Approved" means approved in writing by the Council.

"Approved materials" means material approved in writing by the Council.

"Battery cage" means a wire and metal mesh cage divided into one or more compartments in which poultry is kept.

"Council" means the Council of the Shire of Werribee.

"Dwelling" shall include a living room sleepout or tent, and all rooms used for sleeping, living or cooking.

"Litter" includes wood shavings, tan bark, straw or dry glass clippings or other similar suitable clean material satisfactory to Council's Chief Health Inspector.

"Person" includes the owner or occupier or the person in charge of premises.

"Poultry" includes fowls, turkeys, ducks and geese.

PART II

This part shall apply to areas zoned as residential "A", residential "B", residential "C" and reserved residential in the Shire of Werribee Planning Scheme and residential "C" and reserved residential under the Melbourne Metropolitan Planning Scheme under the Town and Country Planning Acts and all such areas are hereby declared to be residential areas for the purpose of this part of this By-Law.

1. A person shall not keep or cause or permit to be kept on any premises within the area to which this part applies a number of fowls greater than twenty-five.

2. A person shall not keep in any poultry house or similar structure a number of fowls greater than the number produced by dividing the area in square feet of such poultry house or similar structure by four unless confined in approved battery cages.

3. A person shall not keep or cause or permit to be kept on any one property more than a total of two turkeys ducks or geese.

4. A person shall not keep any poultry on any premises otherwise than in a poultry house or similar approved structure or an approved enclosure or approved battery cage and unless such poultry house or similar approved structure or enclosure or battery cage is—

- (a) of a height not exceeding 2.5 metres;
- (b) distant at least 23 metres from the boundary of the street or road towards which the residential building on such property faces;
- (c) distant at least 3 metres from any other street or road of a greater width than 8 metres;
- (d) distant at least 1.5 metres from any other street or road of a lesser width than 8 metres;
- (e) distant at least 1.5 metres from the boundary of any adjoining allotment of land;

(f) distant at least 12 metres from any dwelling whether on the same or adjoining land.

5. Every poultry house or similar approved structure or enclosure, except approved battery cages, shall be rendered rat-proof by placing galvanised iron, jointed brick-work, cement sheet or concrete around the foundations to a depth of at least 1.5 metres below ground level and all walls shall be constructed of approved rat-proof material.

6. Every poultry house or similar approved structure or enclosure, except approved battery cages, shall be roofed with approved material and paved with approved impervious material and the surface level of the floor shall be at least 75 mm above the level of the surrounding ground and shall be constructed so as to hold 150 mm in depth of litter.

7. Every approved battery cage in which poultry is kept in an area zoned as residential shall be contained within a building having a permanent roof and any walls shall be constructed of approved materials and have a floor raised at least 75 millimetres above the level of the surrounding ground.

PART III

Provisions Relating to Poultry Farms

In this section unless inconsistent with context or subject matter:

"Poultry farm" shall mean any premises on which there is kept at any time a greater number of poultry than twenty-five.

1. A person shall not keep poultry on any poultry farm otherwise than in a poultry house or similar structure or enclosed poultry run or approved battery cage.

2. Where the number of poultry is at any time greater than twenty-five every poultry house or similar structure or any enclosed poultry run or any approved battery cage shall be—

- (a) distant at least 23 metres from the boundary of the street or road to which the building has a frontage;
- (b) distant at least 3 metres from any other street;
- (c) distant at least 3 metres from the boundary of any adjoining allotment of land;
- (d) distant at least 30 metres from any dwelling whether on the same or adjoining land, excepting only that the owner or occupier may erect incubators or brooder houses not less than 12 metres from his own dwelling.

3. Every poultry house or similar structure or approved battery cage shall be roofed with approved material with gutters leading to water tanks or to storm water drains to the satisfaction of Council's Chief Health Inspector.

4. The ground surrounding every poultry house or similar structure or approved battery cage shall be adequately and suitably drained.

5. The floor beneath any approved battery cage and the floor of any poultry house or similar structure shall be built up so that the surface shall be at least 75 millimetres about the level of the surrounding ground.

PART IV

(General Provisions)

These provisions shall apply to all premises.

1. The owner or occupier shall keep the area of land within 1.5 metres of any poultry house, similar structure, enclosure or approved battery cage free from all dry grass, weeds, refuse or other materials capable of harbouring rats or other vermin.

2. The owner or occupier shall cause the poultry house, similar structure or enclosure or approved battery cage to be thoroughly cleaned from time to time as often as may be necessary and shall keep the same in a clean wholesome and sanitary condition at all times.

3. A person shall not keep or store or cause or permit to be kept or stored on any property where poultry is kept any food for consumption by poultry unless such food is kept or stored in rat-proof receptacles or rat-proof buildings.

4. Poultry droppings, litter and refuse shall be moved from the premises from time to time and in such a manner as Council's Chief Health Inspector directs so as not to cause a nuisance or offensive condition.

5. The owner or occupier of all premises where poultry is kept shall cause all dead poultry to be stored in a fly-proof and rat-proof receptacle fitted with a tight fitting lid pending destruction of such dead poultry.

6. The owner or occupier of all premises shall destroy all dead poultry thereupon by completely burning or burying the carcass to the satisfaction of Council's Chief Health Inspector or other authorized person.

7. Any person guilty of a wilful act or default contrary to this By-Law shall be liable to a penalty of not more than \$100.00 and to a further penalty of not more than \$10.00 for each day on which such offence is continued after a conviction or order by any Court.

The Resolution adopting this By-Law No. 75 was agreed to at the meeting of the Council held on 28 November 1977 and confirmed on 27 February 1978.

The corporate seal of the President, Councillors and Ratepayers of the Shire of Werribee was hereunto affixed, in the presence of—

(SEAL) S. D. SOUTHWICK, President
M. J. BLOXHAM, Councillor
J. T. KERR, Shire Secretary

Approved by the Governor in Council, 12 February 1980—
TOM FORRISTAL, Clerk of the Executive Council 2907

SHIRE OF WERRIBEE

BY-LAW No. 79

Refuse and Rubbish

A By-Law of the Shire of Werribee made under the provisions of the *Health Act 1958* and of every other power it thereunto enabling and numbered 79 for the purpose of preventing or regulating the deposit of refuse and rubbish upon streets and other lands and places under the control of the council.

In pursuance of the powers conferred by the *Health Act* and by every other power it thereunto enabling in that behalf the President, Councillors and Ratepayers of the Shire of Werribee hereby order as follows:—

1. This By-Law shall apply to and have operation throughout the whole of the municipal district of the Shire of Werribee.

2. In this By-Law, unless otherwise indicated by the context or subject matter—

"Authorised Officer" means a person appointed by the Council as a Health Inspector.

"Building" means any building of Class II. or Class III. Occupancy as defined in the *Uniform Building Regulations 1974* or any consolidation or amendment thereof within the municipal district of the Shire of Werribee.

"Council" means the council of the Shire of Werribee.

"Owner" bears the same meaning as in the *Health Act 1958* or any consolidation or amendment thereof.

3. The owner of any building shall upon being required to do so in writing by the Council or its authorised officer provide on the site of the building, within the time specified in such written requirement, and in the position and manner specified therein, an area as specified therein for the storage of garbage receptacles—

(1) on the days on which garbage is collected from the building. The area to be so provided shall—

- (a) have a graded impervious floor; and
- (b) be situated within the curtilage of the site of the building, but not more than 3 metres from the frontage of the site to the street, or in such other position as is specified in the written requirement; and
- (c) be so screened as to prevent a view thereof from the street; and
- (d) be maintained in a clean, tidy and sanitary condition to the satisfaction of Council's authorised officer—

(2) on days other than days on which garbage is collected from the building. The area to be so provided shall—

- (a) have a graded impervious floor; and
- (b) be so situated within the curtilage of the site of the building as not to constitute an eyesore or nuisance to the occupiers of adjoining sites or from the streets; and
- (c) be so situated as to be inaccessible to marauding dogs; and
- (d) be maintained in a clean, tidy and sanitary condition to the satisfaction of Council's authorised officer.

4. The owner of any building upon the site of which an area or areas have been so provided shall not permit or allow any garbage, receptacles to be stored upon the said site otherwise than in the area or areas so provided.

5. Any person or persons committing a breach of this By-Law shall for every breach be liable to a penalty of not more than \$100 and in the case of a continuing offence a further daily penalty of not more than \$10.00.

Resolution for passing this By-Law agreed to by the Council of the Shire of Werribee on 28 November 1977 and confirmed on 27 February 1978.

The corporate seal of the President, Councillors and Ratepayers of the Shire of Werribee was hereunto affixed, in the presence of—

(SEAL) S. D. SOUTHWICK, President
M. J. BLOXHAM, Councillor
J. T. KERR, Shire Secretary

Approved by the Governor in Council, 30 January 1980—
TOM FORRISTAL, Clerk of the Executive Council 2908

SHIRE OF WERRIBEE

BY-LAW No. 81

Animal By-Law

A By-Law of the Shire of Werribee made under sections 197, 198 and 800 of the *Local Government Act 1958* and section 93 of the *Health Act 1958* for:—

- (a) regulating the keeping of animals or birds;
- (b) regulating restricting restraining or prohibiting the erection construction use occupation conversion and alteration of and any addition to buildings or erections; and
- (c) for prohibiting or regulating the sale or purchase or the exposing for sale of animals or birds in any street road or public place;
- (d) suppressing nuisances;
- (e) regulating the conduct of persons using or being upon or in pleasure grounds or places of public resort or public recreation;
- (f) fixing the distance from any dwelling within which it shall be unlawful to keep any such place or animal or to store any such thing.

In pursuance of the powers conferred by the *Local Government Act 1958*, the *Health Act 1958* and of any and every other power it thereunto enabling the President Councillors and Ratepayers of the Shire of Werribee orders as follows:—

PART I.—GENERAL

1. This By-Law shall be known as the Animal By-Law.
2. In this By-Law unless inconsistent with the context or subject-matter—

"Animal" means cow ox heifer steer bull bullock horse goat swine pig and sheep and the young thereof.

"Approved materials" means materials approved by the Building Surveyor or Chief Health Surveyor of the Municipality.

"Approved type of Hive" means any type of bee hive approved by the Chief Health Surveyor.

"Bird" includes every species of bird whether in a natural or domestic state but except in relation to Clause 22 of this By-Law does not include any domestic fowl turkey duck or goose.

"Council" means the Council of the Municipality of the Shire of Werribee.

"Dog" includes a dog of either sex over the age of six months.

"Dwelling" includes a living room sleep-out or tent and all rooms for sleeping living and cooking.

"Ferret" includes a ferret of either sex over the age of three months.

"Frontage" means the boundary line between any land and the street on which such land abuts or where such land abuts on more than one street then the boundary line between such land and the street to which the main building fronts or where there is no building on the said land then the shortest boundary line between such land and any street on which such land abuts.

"Horse" includes any stallion mare gelding pony colt or foal ass or mule or camel or any animal used for burden or draft or for carrying persons.

"Stable" includes any building or erection used or intended to be used for the purpose of confining protecting or sheltering any horse.

PART II.—ANIMALS

3. A person shall not keep ride exercise lead train tether feed or graze any animal on any land which the Council has at any time purchased or rented or otherwise provided or has been granted or given by any person for the providing of pleasure grounds or places of public resort or public recreation.

4. A person shall not keep any animal on any property except with written permission of the Council.

5. The Council may grant permission for such number of animals as it considers appropriate to be kept on any property if it is of the opinion that the keeping of such number of animals will not cause any nuisance.

6. Should any nuisance subsequently arise from the keeping of such number of animals as Council has granted permission to be kept on the property the Council may cancel such permission and thereafter such permission shall have no force or effect.

7. A person shall not on any land keep any animal within a distance of—

- (a) (i) 15 metres from any street or road to which such land has a frontage;
- (ii) 3 metres from any other street or road;
- (iii) 12 metres from the boundary of any adjoining allotment of land;
- (iv) 12 metres from any dwelling whether on the same or any adjoining land.

(b) Provided that where the Council is satisfied that any animal has been kept in any structure or enclosure prior to 25 July 1973 (being the date By-Law No. 56 came into operation) and such structure or enclosure does not comply with any or all of the distances specified in this clause the Council may consent to a lesser distance being permitted subject to such other conditions, if any, as may be specified by Council being complied with. Should any nuisance conditions subsequently arise on the premises such consent may be withdrawn by the Council and thereafter such consent shall have no force or effect and the distances prescribed in this clause shall apply.

8. The occupier of any land on which are kept any animals shall—

- (a) cause all manure refuse and rubbish produced or accumulated on such land to be forthwith placed in a properly constructed fly and vermin proofed receptacle with impervious walls and impervious floor and shall—
 - (i) at all times maintain such receptacle in a good state of repair so as to prevent the escape or leakage of the contents;
 - (ii) keep such receptacle at all times covered with a fly and vermin proof lid and from time to time as may be required by the Chief Health Surveyor of the Municipality effectively deodorize the receptacle and its contents;

(iii) cause the contents of such receptacle to be removed and disposed of to the satisfaction of the Chief Health Surveyor at least once in every week;

- (b) cause the floor of such receptacle to be paved with concrete or other approved impervious material and properly graded and drained to an approved silt trap and outlet;
- (c) maintain such receptacle at all times in a clean and sanitary condition.

PART III.—BEES

9. A person shall not keep bees on any property in such number or manner as may cause nuisance.

10. The occupier of any property shall not keep bees in a hive situation within 50 metres of any dwelling on any adjoining allotment or within 25 metres of any street or road.

11. A person shall not keep bees on any property other than in a location approved in writing by the Chief Health Surveyor.

12. A person shall not keep any bees on any property except in an approved type of hive.

PART IV.—BIRDS

13. A person shall not on any property keep birds unless such birds are kept in cages or structures constructed of approved materials. A person shall not keep birds within a distance of—

- (a) 15 metres from any street or road to which such land has a frontage;
- (b) 3 metres from any other street or road;
- (c) 1.5 metres from the boundary of any adjoining allotment of land;
- (d) 12 metres from any dwelling on any adjoining land.

Provided that such distances shall not apply to any movable cage constructed entirely of wire in which not more than 3 birds are kept.

14. The occupier of any land on which birds are kept shall maintain all cages or other structures in which birds are kept at all times in a clean and sanitary condition.

PART V.—FERRETS

15. A person shall not on any property keep ferrets unless such ferrets are kept in cages or structures of approved materials.

16. A person shall not keep ferrets within a distance of—

- (a) 15 metres from any street or road to which such land has a frontage;
- (b) 3 metres from any other street or road;
- (c) 1.5 metres from the boundary of any adjoining allotment of land;
- (d) 12 metres from any dwelling whether on the same or any adjoining land.

17. A person shall not keep or permit or suffer to be kept on any property more than 4 ferrets.

PART VI.—DOGS AND CATS

18. A person shall not, except with the written permission of the Council, keep or permit or suffer to be kept on any property more than two dogs and four cats.

19. The Council may grant such permission if it is of the opinion that in so acting there will be no nuisance created by the proposed keeping of more than two dogs and four cats on any property.

20. Should any nuisance subsequently arise from the keeping of more than two dogs and four cats on any property in respect to which Council has granted permission to keep any such dogs or cats the Council may cancel such permission and thereafter such permission shall have no force or effect.

21. A person shall not keep any dog in a kennel, enclosure or run within a distance of—

- (a) 15 metres from any street or road to which such land has a frontage;
- (b) 3 metres from any other street or road;

- (c) 1.5 metres from the boundary of any adjoining allotment of land;
- (d) 12 metres from any dwelling on any adjoining land.

PART VII.—SALES IN STREETS

22. A person shall not sell or purchase or expose for sale any animal or bird in any street road or public place. For the purpose of this clause bird shall include any domestic fowl turkey duck or goose.

PART VIII.—CLEANLINESS

23. The ground surrounding any stable or receptacle for manure or cage or structure or kennel or enclosure shall be well drained to the satisfaction of the Chief Health Surveyor of the Municipality.

24. The occupier of any land on which any stable, cage, structure kennel or enclosure is erected shall keep the area of land within 1.5 metres of such stable, cage, structure, kennel or enclosure free from all dry grass weeds refuse rubbish or other materials capable of harbouring rats or vermin.

25. A person shall not keep or store or cause or permit to be kept or stored on any land where animals or birds or ferrets or dogs or cats are kept any food for consumption by such animals or birds or ferrets or dogs or cats unless such food is kept or stored in rat proof receptacles or rat proof buildings.

26. The occupier of any land shall cause any stable, cage, structure, kennel, enclosure, or run thereon to be thoroughly cleaned from time to time as often as may be necessary and shall keep the same at all times in a clean and sanitary condition to the satisfaction of the Chief Health Surveyor of the Municipality.

27. The occupier of any land on which any animal or bird is kept shall cause any animal or bird kept thereon which suffers from any infectious disease communicable to man to be forthwith destroyed and disposed of to the satisfaction of the Chief Health Surveyor of the Municipality.

PART IX.—MISCELLANEOUS

28. This By-Law, except Clause 22 hereby, shall apply to and have operation throughout those parts of the municipal district set out and described in the Schedule hereto which are hereby declared to be populous or residential areas and Clause 22 hereof shall apply to and have operation throughout the whole of the municipal district.

29. Every person guilty of any wilful act or default contrary to any provisions of this By-Law shall be liable to a penalty of not more than \$400 and any person guilty of a continuing offence against any provisions of this By-Law shall be liable to a penalty of not more than \$10 for each day of which such an offence is continued after conviction or order by any Court.

THE SCHEDULE HEREINBEFORE REFERRED TO

All areas zoned as Residential, Reserved Living or Business under the Melbourne Metropolitan Planning Scheme or Residential, Reserved Residential or Commercial under the Shire of Werribee Planning Scheme or within a distance of 60 metres from any such areas.

The Resolution adopting this By-Law No. 81 was agreed to by the Council of the Shire of Werribee at a meeting held on 25 February 1980 and confirmed on 24 March 1980.

The corporate seal of the President, Councillors and Ratepayers of the Shire of Werribee was hereunto affixed, in the presence of—

(SEAL) M. J. BLOXHAM, President
K. B. SKEHAN, Councillor
J. T. KERR, Shire Secretary

Approved by the Governor in Council, 7 April 1981—
TOM FORRISTAL, Clerk of the Executive Council 2909

SHIRE OF YACKANDANDAH

By-Law No. 18

Petrol Pumps By-Law

Notice is hereby given that the Council of the Shire of Yackandandah has made a By-Law pursuant to Section 7 of the *Petrol Pump Act 1958* for or with respect to—

- (a) the placing fixing and maintaining of petrol pumps in or on footways and of any apparatus pipes and appliances in, on, or under footways for the supply of Motor or other spirit to such petrol pumps and the removal of such petrol pumps apparatus pipes and appliances;
- (b) the granting renewal and transfer of licences and applications therefore;
- (c) licences and conditions to be contained in licences;
- (d) prescribing fees—
(i) for the granting or renewal of a licence;
(ii) for the transfer of a licence;
- (e) providing for a proportionate reduction of fees payable in respect of licences granted for any number of months less than twelve months; and
- (f) insurance by licensees against liabilities which may be incurred by them in respect of petrol pumps;
- (g) repealing By-Law No. 8 of the Shire of Yackandandah.

A copy of the By-Law is available for inspection free of charge, during office hours of the office of the Council, High Street, Yackandandah.

2904

D. J. GRIFFITHS, Shire Secretary

WESTERNPORT WATERWORKS TRUST

Notice to owners of tenements in the under-mentioned streets and private streets, lanes, courts and alleys opening thereto. The main pipe in the said street being laid down, the owners of all tenements situated as under are hereby required on or before 1 June 1981 to cause a proper pipe and stop cocks to be laid so as to supply water with such tenements from the main pipe:—

Newhaven Urban District

To Lot 492 Phillip Island Highway.
To lot 336 Manly Place.

Cowes Urban District

To Lot 23 Lawrence Avenue.
2957 C. F. BEASLEY, Secretary

LILYDALE SEWERAGE AUTHORITY

CONSTRUCTION OF SEWERS—SEVILLE

The Lilydale Sewerage Authority gives notice that it intends to construct sewers in the area detailed below.

A plan showing details of the proposed works may be inspected by any persons during office hours, 8.30 a.m. to 6.15 p.m. Thursday, and 8.30 a.m. to 5.00 p.m. all other weekdays at the Authority office, 7-9 John Street, Lilydale.

The proposed alignment of the sewer is as follows:

At Seville, in the railway reservation adjacent to Kylie Lane, across Kylie Lane and English Street and thence eastwards in private properties to Railway Road.

3032

W. L. HALSE, Secretary

WARRNAMBOOL SEWERAGE AUTHORITY

GENERAL NOTICE

The above mentioned Sewerage Authority, having made sewers for carrying off the sewage from each and every property which, or any part of which abuts on the streets or parts of streets, in which such sewers are laid, and which are included within the Sewerage Area, hereinafter described, do hereby declare that on and after 1 July 1981 each and every property which or any part of which abuts on the said streets or parts of streets shall be deemed to be a sewerage property within the meaning of the *Sewerage Districts Act 1958*.

The boundaries of the Sewerage Areas hereinafter referred to are:

SEWER AREA NO. 142

Hopetoun Road

That part of the Warrnambool Sewerage District located in the Parish of Wangoom, County of Villiers which is bounded to the north and east by Sewer Area No. 37, to the south by Sewer Area No. 55 and to the west by Sewer Areas No. 55 and 36.

SEWER AREA NO. 143

Queens Road-Donovans Road

That part of the Warrnambool Sewerage District located in the Parish of Wangoom, County of Villiers and comprising that part of Crown Allotments 134 and 135 east of the southerly projection of the west boundary of Crown Allotment 132, but excluding those areas declared in Sewer Areas 52, 65, 75, 78, 105, 106 and 121. 2971

Notice is hereby given that the Sunraysia Gliding Club has applied for a lease pursuant to Section 134 of the Land Act 1958 for a term of 21 years in respect to allotment 1 section 84 block E parish of Mildura containing 201.9 hectares as a site for amusement and recreation and associated social activities connected therewith. 2530

NOTICE OF SALE OF BUSINESS

The butchers business of D. & R. Haycox Nominees Pty. Ltd. at 2/271 Bay Street, North Brighton has been sold to Julius Redlich & Sons Pty. Ltd. with effect from 2 May 1981. All liabilities of the said business up to the said date are for the account of the said Vendor.

HOLDING REDLICH & CO., purchaser's solicitors, 174 Victoria Parade, East Melbourne 2958

On 30 April 1981 I, Colin Ray Drummy of Gap Road, Riddells Creek retired from the Partnership of C. R. Drummy and J. R. Fox trading as The Fruit Basket Riddells Creek, and have no further interests therein. 3043

NUMURKAH GOLF CLUB

Notice is hereby given that the Numurkah Golf Club has applied for a lease pursuant to Section 134 of the Land Act 1958 for a term of 21 years in respect of Allotment 1 No section, Township of Numurkah containing approximately 50.58 hectares as a site for amusement and recreation and social activities connected therewith. 2950

Notice is hereby given that the partnership hereinbefore subsisting between Ivan Rendell, Roydon Rodrigues, Ray Jones and Hans Dietrich Koberg carrying on business as Refrigeration Engineers at 21 Byron Street, Elwood, Melbourne Dock Yard and Environs under the style or firm of Container Refrigeration Services has been dissolved by mutual consent as from 1 May 1981 so far as concerns the said Hans Dietrich Koberg.

Dated 23 April 1981

IVAN RENDELL
ROYDON RODRIGUES
RAY JONES
HANS DIETRICH KOBERG

2911

Notice is hereby given that the partnership heretofore subsisting between the undersigned Ronald John Harris, Linda Carolyne Harris, Bruce Charles Shuttleworth and Thelma Mary Bates carry on business as panel beaters and spray painters at 447 Joseph Street Ballarat under the name of "Eastern Panels" has been dissolved by mutual consent as from 4 March 1981.

Dated at Ballarat, 25 April 1981

Witness to all signatures—JOHN SMALL

R. HARRIS
L. HARRIS
B. SHUTTLEWORTH
M. BATES

2912

NOTICE OF DISSOLUTION OF PARTNERSHIP

Notice is hereby given that the partnership heretofore subsisting between the undersigned Eric David Granger, Lynette Mary Granger both of 37 Lansdowne Street, Pascoe Vale and Richard de Walden Eagles and Kathleen Irene Eagles both of 6 Leigh Court, Macleod under the name of "Kismet Park Receptions" has been dissolved by mutual consent as from 4 April 1981. All debts due to and owing by the said late firm will be received and paid by Richard de Walden Eagles and Kathleen Irene Eagles who will continue to carry on the business at the same place.

Dated 8 May 1981

E. GRANGER
L. GRANGER
R. EAGLES
K. EAGLES

2913

Notice is hereby given that the partnership heretofore subsisting between Foley Virtanen Nominees Pty. Limited of Suite 19, 545 St. Kilda Road, Melbourne of the one part and Trevor Mort and Doreen Mort both of Lot 271 Favourite Hill Road, Pearcevale of the other part carrying on business as Tool Makers at Factory 9, 9 Brooklyn Avenue, Dandenong under the style or firm name of T. & D. Tooling has been dissolved as from 16 July 1979 so far as concerns the said Foley Virtanen Nominees Pty. Limited which retires from the said firm.

Dated 6 May 1981

BARKER HARTY & CO., solicitors, 26th Level, 459 Collins Street, Melbourne, Vic. 3000 2914

PARTNERSHIP

ROCCO MARIO CONDELLO AND PAUL APOSTOLA

Take notice that the partnership of Rocco Mario Condello and Paul Apostola conducting business at Shops 22 and 23 Eltham Shopping Mall, Arthur Street, Eltham, was dissolved on 24 April 1981. Paul Apostola will accept no responsibility for any debts or liabilities incurred without his prior consent after that date. 2946

Notice is hereby given that the partnership between Joseph Guy Frigo and Peter Joseph Frigo carrying on business as Garage Proprietors at 145 Ballarat Road Footscray under the firm name of Douglas Service Station has been dissolved as from 1 October 1980. Joseph Guy Frigo has retired from the Partnership and the business will be carried on by Peter Joseph Frigo who will be responsible for payment of all debts and liabilities of the firm.

Dated 6 May 1981

J. G. FRIGO
P. J. FRIGO

2967

Notice is hereby given that the partnership previously carried on by George Griffith, Dawn Louise Griffith, and Rodney George Griffith as a Motor Vehicle Service Station and Garage and Vehicle Testing Centre at the premises known as "B.P. Cranway Service Station" at the corner of High and Bakewell Streets, Cranbourne, was dissolved as from 30 April 1981, as far as the said George Griffith and Dawn Louise Griffith are concerned. The business is being continued at the same address by the said Rodney George Griffith in partnership with Colin Murray Kirkcaldy.

R. L. EAGLE, solicitor, 63 High Street, Cranbourne, 3977, telephone (059) 96 1600 2973

Companies Act 1961—In the matter of ROTHSTEIN (HOLDINGS) PTY. LTD. (in Voluntary Liquidation)—Members' Winding Up

Notice is hereby given that at an extraordinary general meeting of Rothstein (Holdings) Pty. Ltd. duly convened and held at the registered office of the Company on 11 May 1981 the following resolution was proposed and passed as a special resolution:

"That the Company be wound up voluntarily."

It was also resolved by ordinary resolution that Arnold Geoffrey Saffer be appointed liquidator.

Dated 12 May 1981

2915

A. G. SAFFER, Liquidator

Companies Act 1961—In the matter of LOURAY PTY. LTD. (in Voluntary Liquidation)—Members' Winding Up

Notice is hereby given that at an extraordinary general meeting of Louray Pty. Ltd. duly convened and held at the registered office of the Company on 11 May 1981 the following resolution was proposed and passed as a special resolution:

"That the Company be wound up voluntarily."

It was also resolved by ordinary resolution that Arnold Geoffrey Saffer be appointed liquidator.

Dated 12 May 1981

2916

A. G. SAFFER, Liquidator

Companies Act 1961—In the matter of DOVID PTY. LTD. (in Voluntary Liquidation)—Members' Winding Up

Notice is hereby given that at an extraordinary general meeting of Dovid Pty. Ltd. duly convened and held at the registered office of the Company on 11 May 1981 the following resolution was proposed and passed as a special resolution:

"That the Company be wound up voluntarily."

It was also resolved by ordinary resolution that Arnold Geoffrey Saffer be appointed liquidator.

Dated 12 May 1981

2917

A. G. SAFFER, Liquidator

Companies Act 1961—In the matter of TANIA HOLDINGS PTY. LTD. (in Voluntary Liquidation)—Members' Winding Up

Notice is hereby given that at an extraordinary general meeting of Tania Holdings Pty. Ltd. duly convened and held at the registered office of the Company on 11 May 1981 the following resolution was proposed and passed as a special resolution:

"That the Company be wound up voluntarily."

It was also resolved by ordinary resolution that Arnold Geoffrey Saffer be appointed liquidator.

Dated 12 May 1981

2918

A. G. SAFFER, Liquidator

Companies Act 1961
DEMAREST & McNEILL PTY. LTD.
NOTICE OF MEETING

Notice is hereby given of a Meeting of Creditors of Demarest & McNeill Pty. Ltd. to be held at the Institute of Chartered Accountants, 9th Floor, 140 Queen Street, Melbourne on 21 May 1981 at 10.00 a.m.

The Company has convened an Extraordinary General Meeting of its members for the same day for the purpose of considering the passing of the following special resolutions:

"That the Company be wound up voluntarily."

"That Edward Peter Taylor, Chartered Accountant, of 583 Hampton Street, Hampton be appointed Liquidator of the Company."

The Creditors of the Company will be asked to consider the following matters:

"The appointment of a Liquidator."

"The remuneration of the Liquidator."

"Appointment of a Committee of Inspection, if required."

Please note that only creditors who have lodged a form of Proof of Debt will be entitled to vote at the meeting of the creditors.

Completed forms may be forwarded to the office of E. P. Taylor, Chartered Accountant, 583 Hampton Street, Hampton, 3188, or be handed to the Chairman on the day of the meeting.

2921.

GRAEME COOPER, Director

Companies Act 1961—In the matter of N. E. & N. J. CUTTRISS PTY. LTD. (in Voluntary Liquidation)—Members' Winding Up

Notice is hereby given that at an extraordinary general meeting of N. E. & N. J. Cuttriss Pty. Ltd. duly convened and held at the registered office of the Company on 11 May 1981 the following resolution was proposed and passed as a special resolution:

"That the Company be wound up voluntarily."

It was also resolved by ordinary resolution that Arnold Geoffrey Saffer be appointed liquidator.

Dated 12 May 1981

2919

A. G. SAFFER, Liquidator

Companies Act 1961—In the matter of SOUND CONSTRUCTIONS (BULLEEN) PTY. LTD. (in Voluntary Liquidation)—Members' Winding Up

Notice is hereby given that at an extraordinary general meeting of Sound Constructions (Bulleen) Pty. Ltd. duly convened and held at the registered office of the Company on 11 May 1981 the following resolution was proposed and passed as a special resolution:

"That the Company be wound up voluntarily."

It was also resolved by ordinary resolution that Arnold Geoffrey Saffer be appointed liquidator.

Dated 12 May 1981

2920

A. G. SAFFER, Liquidator

Companies Act 1961—In the matter of NOBILITY FURNITURE PTY. LTD. (in Liquidation)

Notice is hereby given that at an extraordinary Meeting of the Members of the abovenamed Company held on 11 May 1981 it was resolved that the Company be wound up voluntarily and at a Meeting of Creditors held on the same day pursuant to Section 260, it was resolved that for such purpose Mr E. T. Bent of 144 Jolimont Road, East Melbourne be appointed Liquidator.

Notice is also given that after 21 days from this date I shall proceed to distribute the assets. All creditors having any claims against the Company should furnish particulars of same by that date, otherwise I shall proceed to distribute the assets without regard to their claim.

Dated 11 May 1981

E. T. BENT, Liquidator

Bent & Cogle, public accountants, 144 Jolimont Road, East Melbourne, Vic. 3002

2922

Companies Act 1961, Section 272 (2)
864 NOMINEES PTY. LTD. (IN LIQUIDATION)

A General Meeting of Shareholders of the above-named Company will be held at 40A Bayview Crescent, Black Rock on 12 June 1981 at 12 noon to receive and accept the liquidators final report.

2924

D. WOODINGTON, Liquidator

COMPANIES ACT 1961

Notice is hereby given pursuant to Section 272 of the Companies Act, that a Final Meeting of the members of Fraser Taggart Sales Pty. Ltd. will be held at the office of Davis, Knott & Co., 121 Rosamond Road, Maidstone, at 10.00 a.m. on Monday 22 June 1981.

Business—To receive a Final Explanation of the Winding Up of the Company from the Liquidator.

2925

Companies Act 1961—In the matter of DEER PARK DISCOUNTS PTY. LTD. (Trading as Pavlidis Emporium)—Notice Re Meeting of Creditors, Pursuant to Section 260

Notice is hereby given that a Meeting of creditors of the abovenamed Company will be held at the Treasury Room, Sheraton Hotel, 13 Spring Street, Melbourne, on Friday, 5 June 1981 at 11 a.m. the company having convened a meeting of its members for the same day for the purpose of considering a Resolution that the Company be wound up voluntarily.

Dated 7 May 1981

Mr PAVLIDIS, Director

B. K. Taylor & Co., accountants, 576 St. Kilda Road, Melbourne, Vic., 3004

2926

Companies Act 1961, Section 272

R.D.J. HOLDINGS PTY. LTD.
 T. & M.H. HOLDINGS PTY. LTD.
 BEVALD PTY. LTD.
 H. HAMMOND PTY. LTD.
 A.B.S. NOMINEES PTY. LTD.
 ABBOT PLASTICS PTY. LTD.
 A. R. SIMPSON & CO. PTY. LTD.
 WOOD MACHINISTS PTY. LTD.
 C. & M. LIMESTONE QUARRIES PTY. LTD.
 NEATH PROPERTIES PTY. LTD.
 BRIL RING PTY. LTD.
 GEM-CUT PTY. LTD.
 PET-GAR PTY. LTD.
 PLATSET PTY. LTD.
 QUALRINGS PTY. LTD.
 INDEX MANUFACTURING COMPANY PTY. LTD.
 DEGA INDUSTRIES PTY. LTD.
 M.S. MEDICAL SERVICES PTY. LTD.
 MORTON PARK PTY. LTD.
 MILLWARD CLARKE PTY. LTD.
 W. R. & P. WOODWARD (JOINERY) PTY. LTD.
 W. R. & P. WOODWARD (CARNEGIE) PTY. LTD.
 W. R. & P. WOODWARD (FRANKSTON) PTY. LTD.
 W. R. & P. WOODWARD (MERCHANDISE) PTY. LTD.
 K.E.M.Z. INVESTMENTS PTY. LTD.
 F.B.P.Z. INVESTMENTS PTY. LTD.
 K.M.L.Z. INVESTMENTS PTY. LTD.
 P.H.V.Z. INVESTMENTS PTY. LTD.
 A.E.M.Z. INVESTMENTS PTY. LTD.
 K.F.B.Z. INVESTMENTS PTY. LTD.
 K.F.E.Z. INVESTMENTS PTY. LTD.
 K.F.H.Z. INVESTMENTS PTY. LTD.
 R.C.O.Z. INVESTMENTS PTY. LTD.
 M.C.O.Z. INVESTMENTS PTY. LTD.
 C.A.V.Z. INVESTMENTS PTY. LTD.
 G.A.P.Z. INVESTMENTS PTY. LTD.
 R.B.C.Z. INVESTMENTS PTY. LTD.
 P.S.B.Z. INVESTMENTS PTY. LTD.
 B.B.C.Z. INVESTMENTS PTY. LTD.
 B.B.F.Z. INVESTMENTS PTY. LTD.
 E.S.C.Z. INVESTMENTS PTY. LTD.
 E.S.S.Z. INVESTMENTS PTY. LTD.
 TARKA INVESTMENTS PTY. LTD.
 PETER WOODWARD (HOLDINGS) PTY. LTD.
 W. R. & P. WOODWARD (VIC.) PTY. LTD.

(Each of the above companies in Liquidation)

Notice is hereby given that the Final General Meeting of each of the above companies will be held at 17 Landcox Street, East Brighton, Victoria at 11 a.m. on 27 June 1981 for the purposes set out in the above Section.

Dated 13 May 1981

MURRAY DEWAR, liquidator, 17 Landcox Street, East Brighton, Victoria, 3187 2923

Companies Act 1961—In the matter of BURCHELL & WALSH FUTURES PTY. LTD. (in Liquidation)

Notice is hereby given that the above Company went into liquidation on 7 May 1981 under the provisions of the Companies Act relating to a Creditors' Voluntary Winding Up and Mr D. J. Cogle was appointed the Liquidator.

Notice is also given that the Liquidator has fixed Monday, 15 June 1981 as the day on or before which creditors of the Company are to prove their debts or claims, otherwise the Liquidator will proceed to distribute the assets without regard to their claim.

Dated 7 May 1981

D. J. COUGLE, Liquidator

Bent & Cogle, public accountants, 144 Jolimont Road, East Melbourne, 3002 2927

In the matter of **ELSOM NOMINEES PTY. LTD.** (trading as Norman Elsom Travel)—Notice of Winding Up Order

Winding-up Order made 30 April 1981.

Name and address of Liquidator—Everett Thomson Bent Esq., 144 Jolimont Road, East Melbourne.

THOMAS H. BELL & CO., solicitors for the petitioner

2983

GRIFFITHS PASTORAL PTY. LTD. (IN VOLUNTARY LIQUIDATION)

SPECIAL RESOLUTION TO WIND UP

At an Extraordinary General Meeting of the above-named Company held at Donald, Victoria on 10 May 1981 the following resolution was passed as a special resolution:

"That the Company be wound up voluntarily."

Notice is also given that Creditors must furnish particulars of any claim against the Company to Alan Fitzgerald, 117 Wyndham Street, Shepparton by 10 June 1981 if they wish to have such claims considered before distribution of Assets.

2947

ALAN FITZGERALD, Liquidator

T. J. PHILLIPS AND SONS PTY. LTD. (IN VOLUNTARY LIQUIDATION)

At an extraordinary general meeting of the above company duly convened and held at 117 Wyndham Street, Shepparton, on 8 May 1981, the following resolution was passed as a special resolution:

"That the company be wound up voluntarily."

Notice is given that creditors having any claim against the company should furnish particulars to the Liquidator, Alan Fitzgerald of 117 Wyndham Street Shepparton by 5 June 1981 after which asset distribution will commence without regard to further claims.

2948

ALAN FITZGERALD, Liquidator

Companies Act 1961—In the matter of DETROIT PROTECTIVE ELECTRONICS PTY. LTD. (in Liquidation)—Notice Convening Final Meeting of Members and Creditors, Pursuant to Section 272

Notice is hereby given pursuant to section 272 of the Companies Act 1961, that a General Meeting of Members and creditors of the abovenamed Company will be held at the Meeting Room, B. K. Taylor & Co., 3rd Floor, Dairy Industry House, 576 St. Kilda Road, Melbourne on Tuesday, 9 June 1981, at 11.00 a.m. for the purpose of having an account laid before them showing the manner in which the winding up has been conducted and the property of the company disposed of and of hearing any explanations that may be given by the Liquidator.

Dated 11 May 1981

B. K. TAYLOR, Liquidator

B. K. Taylor & Co., accountants, 576 St. Kilda Road, Melbourne, Vic. 3004 2948

Companies Act 1961

BELL & MITCHELL PTY. LTD. (trading as Collections, Records and Books) (IN VOLUNTARY LIQUIDATION)

Notice is hereby given that pursuant to Section 272 of the Companies Act 1961, the final meeting of creditors of the Company will be held at the offices of Day, Neilson, Jenkins & Johns, 199-203 Moorabool Street, Geelong on Monday, 22 June 1981 at 10.30 a.m. for the purpose of having an account laid before them showing the manner in which the Winding-up has been conducted and the property of the Company disposed of and of hearing any explanation that may be given by the Liquidator.

Dated 4 May 1981

RUSSELL PEAKE, Liquidator

Day, Neilson, Jenkins & Johns, chartered accountants, 199-203 Moorabool Street, Geelong, 3220 2959

J. & P. JOYCE (AUSTRALIA) PTY. LTD. (IN VOLUNTARY LIQUIDATION)

NOTICE OF FINAL MEETING

Notice is hereby given in pursuance of Section 272 of the Companies Act 1961 that a Final Meeting of Members of J. & P. Joyce (Australia) Pty. Ltd. (in Voluntary Liquidation) will be held at the office of Brian G. Reynolds, 309 Queensberry Street, North Melbourne on 17 June 1981 at 2 p.m. for the purpose of having an account laid before it showing the manner in which the Winding Up has been conducted and the property of the Company disposed of, and hearing any explanation that may be given by the liquidator.

Dated 8 May 1981

2985

Form 92

Companies Act 1961
TRASIMENE CONSULTANTS PTY. LTD.

NOTICE OF MEETING OF CREDITORS

Notice is hereby given that a meeting of the creditors of Trasimene Consultants Pty. Ltd. will be held at the office of E. P. Taylor, 583 Hampton Street, Hampton, on Thursday, 21 May 1981 at 9.15 a.m. for the purposes of:

Appointing a Liquidator of the Company.

Remuneration of the Liquidator.

Appointment of a Committee of Creditors if required.

Dated 5 May 1981

M. NEUMANN, Director

Please note that only creditors who have lodged a form of Proof of Debt will be entitled to vote at the meeting of creditors.

Completed forms may be forwarded to the office of E. P. Taylor, Chartered Accountants, 583 Hampton Street, Hampton, 3188, or be handed to the Chairman on the day of the meeting. 2960

In the matter of the *Companies Act 1961*; and in the matter of—

ARNOLD & SANDOR (KEW) PTY. LIMITED

L. J. HOOKER (HEAD OFFICE) PTY. LIMITED

L. J. HOOKER (KINGS CROSS) PTY. LIMITED

ROSSIAN PTY. LIMITED

SELBY COFFEE LOUNGES PTY. LIMITED

R. W. & L. J. STEWART PTY. LIMITED

Take notice that the affairs of the abovenamed companies are now fully wound-up and that in pursuance of Section 272 (1) of the *Companies Act 1961*, meetings of those companies will be held at the offices of Hooker Corporation Limited 21st Floor, 175 Pitt Street, Sydney on 22 June 1981, for the purpose of laying before the meetings, accounts showing the manner in which the windings-up have been conducted, their property disposed of and giving any explanation thereof.

L. B. HUNTER, Liquidator

Wallace, McMullin & Smail, chartered accountants, 52 Phillip Street, Sydney, N.S.W. 2000 2961

In the matter of the *Companies Act 1961*; and in the matter of MONGANA PROPRIETARY LIMITED (in Liquidation)
—Notice of Final Meeting of Members, Pursuant to Section 272 and Notice to Creditors to Lodge Claims

Notice is hereby given in pursuance of section 272 of the *Companies Act 1961* that a General Meeting of the members of the above company will be held at the office of Messrs Coopers & Lybrand, 18th Floor, 461 Bourke Street, Melbourne on 24 June 1981, at 10.00 o'clock in the forenoon for the purpose of having an account laid before them showing the manner in which the winding up has been conducted and the property of the company disposed of, and hearing any explanation that may be given by the liquidator.

Notice is also given that any creditors who have claims which have not yet been satisfied must lodge such claims with me prior to 10 June 1981 or be excluded from settlement.

Dated 20 May 1981

R. F. HUGHES, Liquidator

Robert Foster Hughes, chartered accountant, 15th Floor, 461 Bourke Street, Melbourne, Vic. 3000 2997

In the Supreme Court of Victoria—No. Co. 11867 of 1981
—In the matter of the *Companies Act 1961*; and in the matter of ALLSTATE CARPET BUYERS PTY. LTD.

Winding Up Order made 14 May 1981.

Name and address of Liquidator: Robert Eastaugh Ramsey, of 499 St. Kilda Road, Melbourne.

MESSRS CORR & CORR, solicitors for the petitioner

3037

In the Supreme Court of Victoria—In the matter of the *Companies Act 1961*; and in the matter of M.H.S. CONSULTANTS PTY. LTD.

Notice is hereby given that a petition for the winding-up of the abovenamed company by the Supreme Court was on 13 April 1981 presented by The Commissioners of the State Bank of Victoria and that the said petition is directed to be heard before the Court sitting at the Fifteenth Court, Law Courts, Lonsdale Street, Melbourne at the hour of 10.30 o'clock in the forenoon on 4 June 1981 and any creditor or contributory of the said company desiring to support or oppose the making of an order on the said petition may appear at the time of hearing by himself or his Counsel for that purpose and a copy of the said petition will be furnished to any creditor or contributory of the said company requiring the same by the undersigned on payment of the regulated charge for the same.

The Petitioner's address is 233 Collins Street, Melbourne.

The Petitioner's Solicitor is I. F. Purbrick of 7th Floor, 125 Swanston Street, Melbourne.

NOTE—Any person who intends to appear on the hearing of the said petition must serve on or send by post to the abovenamed I. F. Purbrick notice in writing of his intention so to do. The notice must state the name and address of the person, or, if a firm, the name and address of the firm, and must be signed by the person or firm, or his or their solicitor (if any), and must be served, or, if posted, must be sent by post in sufficient time to reach the abovenamed not later than 4.00 p.m. in the afternoon of 3 June 1981. 2968

Companies Act 1961

PETER C. P. HALLIDAY & ASSOCIATES PROPRIETARY LIMITED of Suite 19, 96 Camberwell Road, East Hawthorn

Notice is hereby given that a Petition for the winding-up of the abovenamed Company by the Supreme Court was on 7 March 1981 presented by Burns Philp and Company Limited trading as Cafe-Bar International and that the said Petition is directed to be heard before the Court sitting at Melbourne at the hour of 10.30 o'clock in the forenoon on Thursday, 11 June 1981 and any creditor or contributory of the Company desiring to support or oppose the making of an Order on the said Petition may appear at the time of hearing by himself or his Counsel for that purpose; and a copy of the Petition will be furnished to any creditor or contributory of the said Company requiring the same by the undersigned on payment of the regulated charge for the same.

The Petitioner's address is 1st Floor, 340 Collins Street, Melbourne.

The Petitioner's solicitor is Anthony M. Simons, of 6th Floor, 60 Albert Road, South Melbourne.

ANTHONY M. SIMONS, solicitor for the petitioner

NOTE—Any person who intends to appear on the hearing of the said petition must serve on or send by post to the abovenamed Solicitors notice in writing of his intention so to do. The notice must state the name and address of the firm and must be signed by the person or firm or his or their Solicitor (if any) and must be served or if posted must be sent by post in sufficient time to reach the abovenamed not later than 4 o'clock in the afternoon on 10 June 1981. 2974

Companies Act 1961—In the matter of STIFER AUSTRALIA PROPRIETARY LIMITED—Notice of Winding Up Order

Winding up Order made on 9 April 1981.

Name and address of Liquidator appointed: Douglas Ewart Tonkin, care of Marquand & Co., of 51 Queen Street, Melbourne.

2975 REMINGTON & CO., solicitors for the petitioner

Companies Act 1961
CHARDORON HOLDINGS PTY. LTD. (IN VOLUNTARY LIQUIDATION)

MEMBERS' VOLUNTARY WINDING UP

Notice is hereby given that at an Extraordinary General Meeting of members of the above company held on 1 May 1981, it was agreed that the company be wound up voluntarily and that Mr Russell Graeme Peake, Chartered Accountant and Registered Liquidator of the firm of Day, Neilson, Jenkins & Johns be appointed liquidator.

Notice is also given that after 28 days from this date I shall proceed to distribute the assets to the shareholders. All creditors having any claim against the company should furnish particulars of same by that date otherwise I shall proceed to distribute the assets without regard to their claim.

Dated 14 May 1981

R. G. PEAKE, Liquidator
 Day, Neilson, Jenkins & Johns, chartered accountants,
 199-203 Moorabool Street, Geelong, Vic. 3220 2965

Companies Act 1958—In the matter of THE BROADFORD CO-OPERATIVE HOTEL

Notice is hereby given that at an extraordinary general meeting of the abovenamed Company duly convened and held at the Supper Room, Shire of Broadford, 113 High Street, Broadford, on Wednesday, 6 May 1981, at 12.15 p.m. the following Special Resolution was duly passed, viz.:

"That The Broadford Co-operative Hotel be wound up voluntarily as a Members' Voluntary Winding Up and that Barry Keith Taylor of 576 St. Kilda Road, Melbourne be appointed Liquidator for the purposes of such winding up."

Dated 11 May 1981

B. K. TAYLOR, Liquidator
 B. K. Taylor & Co., accountants, 3rd Flood, Dairy Industry House, 576 St. Kilda Road, Melbourne, Vic. 3004 2976

Companies Act 1961
SHOLAKIS HOLDING COMPANY PTY. LTD. (IN LIQUIDATION)

NOTICE OF VOLUNTARY LIQUIDATION—SECTION 254 (2)

At an extraordinary general meeting of Sholakis Holding Company Pty. Ltd. (in Liquidation) duly convened and held at 765 Glenferrie Road, Hawthorn on 13 May 1981, the following resolution was passed as a special resolution:

"That the company be wound up voluntarily and that Erik Lipins, Chartered Accountant of 765 Glenferrie Road, Hawthorn, be appointed liquidator of the company with the power to distribute the assets, *in specie*, amongst its members."

Notice is also given that after twenty-one (21 days from this date) I shall proceed to distribute the assets. All creditors having any claim against the company should furnish particulars of same by that date, otherwise I shall proceed to distribute the assets without regard to their claims.

Dated 13 May 1981

ERIK LIPINS, Liquidator
 Sabri Lipins Cooper, chartered accountants, 765 Glenferrie Road, Hawthorn, 3122 2977

In the Supreme Court of Victoria—Co. No. 11789—In the matter of the *Companies Act 1961*; and in the matter of **COVENTRY PRINTERS PTY. LTD.**

Notice is hereby given that on 23 April 1981, an Order of the Supreme Court for the winding up of Coventry Printers Pty. Ltd. was made and that James Manson Poulton of Peate Marwick Mitchell & Co. of 500 Bourke Street Melbourne in the State of Victoria was appointed Liquidator.

Dated 12 May 1981

ARTHUR ROBINSON & CO., solicitors for the petitioner
 2988

EXTENSION AGENCY PTY. LTD. (IN LIQUIDATION)
CORIO INVESTMENT CO. PTY. LTD. (IN LIQUIDATION)
NOTICE OF FINAL MEETINGS

Notice is hereby given that pursuant to section 272 of the *Companies Act 1961* the final meetings of the members of the above companies will be held at 50 Dow Street, South Melbourne on Tuesday 18 June 1981 at the times set out below—

10.15 a.m. Extension Agency Pty. Ltd.

10.30 a.m. Corio Investment Co. Pty. Ltd.

for the purpose of having an account laid before them showing the manner in which the winding up had been conducted and hearing any explanations that may be given by the liquidator.

Dated 15 May 1981

2978

W. H. M. BELL, Liquidator

In the Supreme Court of Victoria—1981 Co. No. 11922—In the matter of the *Companies Act 1961*; and in the matter of **MEDIA CONTROL PTY. LTD.**

Notice is hereby given that a Petition for the winding up of the abovenamed Company by the Supreme Court was on 5 May 1981 presented by Australian Datronics Limited and that the said Petition is directed to be heard before the Court sitting at the Practice Court, Law Courts, Lonsdale Street, Melbourne at the hour of 10.30 o'clock in the forenoon on Thursday 18 June 1981 and any creditor or contributory of the said Company desiring to support or oppose the making of an Order on the said Petition may appear at the time of hearing by himself or his Counsel for the purpose; and a copy of the said Petition will be furnished to any creditor or contributory of the said Company requiring the same by the undersigned on payment of the regulated charge for the same.

The Petitioner's address is care of the offices of Priestley and Morris, 7th Floor, 450 Collins Street, Melbourne.

The Petitioner's Solicitor is Barker Harty & Co. of 459 Collins Street, Melbourne.

NOTE—Any person who intends to appear on the hearing of the said Petition must serve on or send by post to the abovenamed Barker Harty & Co. notice in writing of his intention so to do. The notice must state the name and address of the person, or if a firm, the name and address of the firm and must be signed by the person or firm, or his or their Solicitor (if any) and must be served, or if posted, must be sent by post in sufficient time to reach the abovenamed not later than 4.00 p.m. on the afternoon of 4 June 1981. 2982

The Companies Act 1961, Section 254 (2) (b)
W. RODGERSON PTY. LIMITED (IN VOLUNTARY LIQUIDATION)

Notice is hereby given that at an Extraordinary General Meeting of the members of the abovenamed company held on 8 May 1981 it was resolved that the company be wound up voluntarily and that Mr Alan Tasman Tudor of Pannell Kerr Forster, Chartered Accountants 500 Bourke Street, Melbourne be appointed Liquidator of the Company for the purpose of the winding up.

Notice is also given that after 21 days from this date I shall proceed to distribute the assets. All creditors having any claims against the company should furnish particulars of same by that date, otherwise I shall proceed to distribute the assets without regard to their claims.

Dated 8 May 1981

A. T. TUDOR, Liquidator
 Care of Pannell Kerr Forster, 500 Bourke Street, Melbourne, 3000 2984

In the matter of **PON NOMINEES PTY. LTD.—Notice of Winding Up Order**

Winding Up Order made 14 May 1981.

Name and address of Liquidator: Douglas Ewart Tonkin, 51 Queen Street, Melbourne 3000.

ROBERT A. GREEN, LL.B., solicitor for the petitioner,
 Glynne Linnell Beaumont 3038

303 ELIZABETH STREET PTY. LIMITED (IN LIQUIDATION)
BUCTON MOTOR COMPANY PTY. LIMITED (IN LIQUIDATION)

FINAL MEETING OF MEMBERS

Notice is hereby given, in pursuance to section 272 of the Companies Act 1961, that a General Meeting of the Members of the abovenamed Companies will be held at 35th Floor, 50 Bridge Street, Sydney on Friday, 26 June 1981 at 10 o'clock in the forenoon, for the purpose of having the liquidator's account laid before them showing the manner in which the winding up has been conducted and the properties of the Companies disposed of and of hearing any explanation that may be given by the Liquidator; and also of determining by resolution the manner in which the books, accounts and documents of the Companies and of the Liquidator thereof shall be disposed of.

Dated 20 May 1981

2986

NEIL F. STEVENS, Liquidator

Companies Act 1961 (as amended), Section 260 (1)—In the matter of MODULAR TRANSPORT AUSTRALIA PTY. LTD.
—Notice of Meeting of Creditors

Notice is hereby given that pursuant to section 260 (1) of the Companies Act 1961 as amended, a meeting of creditors of Modular Transport Australia Pty. Limited will be held at the Committee Room, The Institute of Chartered Accountants in Australia, 140 Queen Street, Melbourne on 4 June 1981 at 10.30 a.m., the Company having convened a meeting of its members for the same day for the purpose of considering a special resolution that the Company be wound up voluntarily.

Dated 18 May 1981

E. H. PETTMAN, Secretary

Pannell Kerr Forster, 500 Bourke Street, Melbourne 3000
2987

Companies Act 1961

BOCASANA PTY. LTD. (IN LIQUIDATION)
CLAVAROIDES PTY. LTD. (IN LIQUIDATION)

Notice is hereby given that at the Extraordinary General Meeting of Members of the abovenamed Companies, held on 14 May 1981, it was resolved at the Companies be wound up voluntarily and that for such purpose, Paul Micheal O'Reilly, Chartered Accountant, of 2nd Floor, 335 Flinders Lane, Melbourne, be appointed Liquidator.

Notice is also given that after 21 days from this date, I shall proceed to distribute the assets of the respective Companies. All Creditors who have any claim against the Companies should furnish particulars of same by that date, otherwise I shall proceed to distribute the assets without regard to their respective claims.

Dated 20 May 1981

PAUL MICHEAL O'REILLY, Liquidator

O'Reilly Osborne & Associates, chartered accountants,
G.P.O. Box 1359M, Melbourne, Victoria 3001. Telephone
61 2276 2989

Companies Act 1961

BRIAN ZOUCHE PUBLICATIONS PTY. LTD. (IN LIQUIDATION)

Notice is hereby given that at the extraordinary general meeting of members of the abovenamed company held on 15 May 1981 it was resolved that the company be wound up voluntarily and that for such purpose, Paul Micheal O'Reilly, chartered accountant, of 335 Flinders Lane, Melbourne, be appointed liquidator.

Notice is also given that after 21 days from this date, I shall proceed to distribute the assets of the company. All creditors who have any claim against the company should furnish particulars of same by that date, otherwise I shall proceed to distribute the assets without regard to their respective claims.

Dated 15 May 1981

PAUL MICHEAL O'REILLY, Liquidator

O'Reilly Osborne & Associates, chartered accountants,
G.P.O. Box 1359M, Melbourne 3001. Telephone 61 2276.
2990

Companies Act 1961—In the matter of CARSOUND ELECTRONICS PTY. LTD. (in Liquidation), formerly trading as "Communication Components", "Carsound Communications"

Notice is hereby given that at an extraordinary meeting of the Members of the abovenamed Company held on 10 April 1981, it was resolved that the Company be wound up voluntarily and at a Meeting of Creditors held later the same day pursuant to section 260 it was resolved that for such purpose Mr L. A. Milner of Suite 2, 497 Burke Road, Camberwell, Chartered Accountant, be appointed Liquidator.

Notice is also given that after 21 days from this date I shall proceed to distribute the assets. All creditors having any claim against the Company should furnish particulars of same by that date, otherwise I shall proceed to distribute the assets without regard to their claim.

Dated 10 April 1981

L. A. MILNER, Liquidator

Venn Milner & Terracall, chartered accountants, Suite 2,
497 Burke Road, Camberwell 3124 2991

The Companies Act 1961—In the matter of DISC NOMINEES PTY. LIMITED (in Liquidation)—Creditors Winding Up.

Notice is hereby given that at meetings of members and creditors of Disc Nominees Pty. Limited duly convened and held at 461 Bourke Street, Melbourne, in the State of Victoria on 11 May 1981, the company was wound up as a creditors voluntary winding up.

Dated 12 May 1981

D. C. CHRISTENSEN, Liquidator
K. J. RUSSELL, Liquidator

Messrs Coopers & Lybrand, chartered accountants, 461
Bourke Street, Melbourne, Vic. 3000 2992

Companies Act 1961

TUPRA PASTORAL CO. PTY. LTD. (IN VOLUNTARY LIQUIDATION)

Notice is hereby given pursuant to section 254 (2) of the Companies Act 1961 that at an extraordinary general meeting of members of Tupra Pastoral Co. Pty. Ltd. duly convened and held at the registered office of the Company, 6th Floor, 422 Collins Street, Melbourne on 15 May 1981, the following resolution was passed as a Special Resolution:

"That the Company be wound up voluntarily and that Alexander Reid Creswick be appointed Liquidator and that he have in addition to all powers vested in him by that appointment power to divide amongst the contributors of the Company in specie any part of the assets of the Company and power to exercise all the powers which (prior to this appointment) were exercisable by the directors of the Company."

Dated 15 May 1981

A. R. CRESWICK, Liquidator

Blake & Riggall, solicitors, 140 William Street,
Melbourne 2993

Companies Act 1961—In the matter of NIBILL PTY. LTD.—Notice of Meeting of Creditors, Pursuant to Section 260

Notice is hereby given that a meeting of Creditors of the abovementioned Company will be held at 177 Eley Road, Blackburn South, 3130 on Friday, 5 June 1981, at 9.30 a.m.

The Company having convened an Extraordinary General Meeting of the members for the same day for the purpose of considering a special resolution that the Company be wound up voluntarily.

Dated 14 May 1981

NICK ZISSIS, Director

Mr Clive Morris, Clive Morris & Staff, public accountants,
177 Eley Road, Blackburn South, Vic., 3130. Telephone
232 3027 2994

Companies Act 1961—In the matter of METALCRAFT PRODUCTS PTY. LTD.—Notice Regarding Meeting of Creditors, Pursuant to Section 260

Notice is hereby given that a meeting of creditors of the abovenamed company will be held at The Victorian Chamber of Manufactures, Room 1, 370 St. Kilda Road, Melbourne, 3004 at 10.30 o'clock on 1 June 1981 the company having convened a meeting of its members for the same day for the purpose of considering a Resolution that the company be wound up voluntarily.

Dated 13 May 1981

A. REILLY, Director

Neville Bird, chartered accountant, 3 Bowen Crescent, Melbourne, 3004. Telephone 267 5111 2995

Companies Act 1961—In the matter of BOB PEARCE CONSTRUCTIONS PTY. LTD.—Notice of Meeting of Creditors, Pursuant to Section 260

Notice is hereby given that a meeting of Creditors of the abovementioned Company will be held at 177 Eley Road, Blackburn South, on Friday, 5 June 1981 at 2 p.m.

The Company having convened an Extraordinary General Meeting of the members for the same day for the purpose of considering a special resolution that the Company be wound up voluntarily.

Dated 13 May 1981

ROBERT PEARCE, Director

Mr Clive Morris, Clive Morris & Staff, public accountants, 177 Eley Road, Blackburn South, Vic., 3130. Telephone 232 3027 2996

The Companies Act 1961, Section 260
WUMP PTY. LTD

NOTICE OF MEETING OF CREDITORS

Notice is hereby given that a Meeting of Creditors of the abovenamed Company will be held at the Boardroom of the Institute of Chartered Accountants, 9th Floor, 140 Queen Street, Melbourne, on Wednesday, 27 May 1981 at 10.00 a.m.

Agenda

1. Appointment of Chairman.
2. Report and Presentation of Statement of Affairs.
3. Discussion.
4. Nomination of Liquidator.
5. Remuneration of Liquidator.
6. Committee of Inspection.
7. Other Business.

Dated 14 May 1981

By order of the Board

F. PETERSON, Director

Messrs Venn Milner & Terracall, chartered accountants, suite 2, 497 Burke Road, Camberwell, Victoria, 3124

2998

Companies Act 1961, Section 272 (2)
N.K.S. LABORATORIES PTY. LTD.
AUSTRALIAN DIE CASTINGS PTY. LTD.
JAN CLEAN PTY. LTD.
GEERPRESS (AUST.) PTY. LTD.
(ALL IN VOLUNTARY LIQUIDATION)

NOTICE OF FINAL MEETINGS

Notice is hereby given that pursuant to Section 272 of the Companies Act 1961 general meetings of the members of the abovenamed companies will be held at Messrs Peat, Marwick, Mitchell & Co., 16th Floor, 500 Bourke Street, Melbourne, on 22 June 1981 at 10.00, 10.15, 10.30 and 10.45 a.m. respectively.

The purpose of the meeting is to lay accounts before it showing the manner in which the winding up has been conducted and the property of the company disposed of and of hearing any explanation that may be given by the Liquidator.

Dated 20 May 1981

K. J. RUSSELL, Liquidator

Messrs Coopers & Lybrand, 461 Bourke Street, Melbourne, 3000 2999

The Companies Act 1961

NOTICE OF FINAL MEETING OF SHAREHOLDERS OF STEVENSON & DARRAGH MACHINERY PTY. LTD. (IN LIQUIDATION)

Notice is hereby given in pursuance of Section 272 of the Companies Act 1961 that a General Meeting of the members of Stevenson & Darragh Machinery Pty. Ltd. (in Liquidation) will be held at 9th Floor, 461 Bourke Street, Melbourne on Monday 22 June 1981 at 10.30 in the forenoon, for the purpose of laying before the meeting an account showing how the winding up has been conducted and the property of the company has been disposed of and of giving any explanation of the account.

3000

M. J. SCOTT, Liquidator

Form 92

The Companies Act 1961

LIGHTING WORLD HOLDINGS PTY. LTD.

NOTICE OF MEETING OF CREDITORS PURSUANT TO SECTION 260

Notice is hereby given that a Meeting of Creditors of the abovenamed Company will be held at the offices of Touche Ross & Co., Chartered Accountants, 12th Floor, 440 Collins Street, Melbourne on Monday, 1 June 1981 at 10.00 a.m., the Company having convened an Extraordinary General Meeting of its Members to be held on the same day for the purpose of considering and if thought fit passing a Special Resolution that the Company be wound up voluntarily.

Agenda

1. Appointment of Chairman.
2. Report and Presentation of Statement of Affairs.
3. Discussion.
4. Nomination of Liquidators.
5. Remuneration of Liquidators.
6. Committee of Inspection.
7. Other Business.

Dated 15 May 1981

A. G. HARRISON, Director

A person is not entitled to vote as a creditor at the Meeting unless he has lodged with the Chairman of the Meeting a proof of debt which he claims to be due to him from the Company.

Touche Ross & Co., chartered accountants, 440 Collins Street, Melbourne, 3000 3001

NOTICE OF MEETING

Notice is hereby given that the liquidator's final meeting of Rover Hotels (Dromana) Pty. Ltd. (In Voluntary Liquidation) for the purpose of considering the Liquidator's Statement as to how the Liquidation has been conducted, and the Company's assets disposed of, and such other matters as permitted by Law, will be held at the office of John H. Donegan & Co., 390 Lonsdale Street, Melbourne on 23 June 1981 at 9.00 a.m.

3002

JOHN H. DONEGAN, Liquidator

NOTICE OF MEETING

Notice is hereby given that the liquidator's final meeting of Willsmere Investments Pty. Ltd. (In Voluntary Liquidation) for the purpose of considering the Liquidator's Statement as to how the Liquidation has been conducted, and the Company's assets disposed of, and such other matters as permitted by Law, will be held at the office of John H. Donegan & Co., 390 Lonsdale Street, Melbourne on 23 June 1981 at 10.00 a.m.

3003

JOHN H. DONEGAN, Liquidator

Companies Act 1961

AVANTI CONSTRUCTIONS PTY. LTD. (IN LIQUIDATION)

NOTICE TO CREDITORS OF INTENTION TO DECLARE A DIVIDEND

A First and Final dividend is intended to be declared in the abovenamed company. Creditors who have not proved their debt by 2 June 1981, will be excluded from this dividend. The date of liquidation was 4 April 1977.

Dated 19 May 1981

ROBERT A. WATERS, Liquidator

Orr, Martin & Waters, chartered accountants, 460 Bourke Street, Melbourne, 3000. Telephone: 602 1644 3018

CYCLONE FORGINGS PTY. LTD. (IN VOLUNTARY LIQUIDATION)

NOTICE CONVENING FINAL MEETING, PURSUANT TO SECTION 272 OF THE COMPANIES ACT 1961

Pursuant to Section 272 of the Companies Act 1961 a general meeting of members of the above-mentioned company will be held at 350 Latrobe Street, Melbourne on Monday 29 June at 9.30 a.m. for the purpose of having an account laid before them showing the manner in which the winding up has been conducted and the property disposed of and of hearing any explanation that may be given by the liquidator.

Dated 15 May 1981

3005

W. P. HARRINGTON, Liquidator

In the Supreme Court of Victoria—1981 No. 11944—In the matter of the Companies Act 1961; and in the matter of H. S. COMMERCIAL DEVELOPERS PTY. LIMITED

Notice is hereby given that a Petition for the Winding up of the abovenamed Company by the Supreme Court was on 18 May 1981, presented by Boral Steel Limited, Victorian Division in the State of Victoria. And that the said Petition is directed to be heard before the Court sitting at Melbourne at the hour of 10.30 o'clock in the forenoon on Thursday 25 June 1981. Any Creditor or Contributory of the said company desiring to support or oppose the making of an Order on the said Petition may appear at the time of hearing by himself or his Counsel for that purpose; and a copy of the Petition will be furnished to any Creditor or contributory of the said company requiring the same by the undersigned on payment of the regulated charge for the same.

The Petitioners address is care of Thomas H. Bell & Co. Solicitors 552 Lonsdale Street, Melbourne.

The Petitioners Solicitors are Thomas H. Bell & Co. 552 Lonsdale Street, Melbourne.

THOMAS H. BELL & CO., solicitors for the said Boral Steel Limited, Victorian Division.

NOTE—Any person who desires to appear on the hearing of the petition must serve on or send by post to the abovenamed Solicitors, notice, in writing of his intention to do so. The notice must state the name and address of the person, or if a firm, the name and address of the firm, and must be signed by the person or firm or his or their Solicitors (if any) and must be served, or, if posted must be sent in sufficient time to reach the abovenamed not later than four o'clock in the afternoon on 24 June 1981. 3019

In the Supreme Court of Victoria—1981 No. Co. 11936—In the matter of the Companies Act 1961; and in the matter of PARMA LISA PTY. LTD.

Notice is hereby given that a petition for the winding up of the abovenamed company by the Supreme Court was, on 8 May 1981, presented by Judith Anne Sonesson. And that the said petition is directed to be heard before the Court sitting at Melbourne at the hour of 10.30 a.m. on 18 June 1981; and any creditor or contributory of the said company desiring to support or oppose the making of an order on the said petition may appear at the time of hearing by himself or his counsel for that purpose; and a copy of the petition will be furnished to any creditor or contributory of the said company requiring the same by the undersigned on payment of the regulated charge for the same.

The Petitioner's address is Flat 1, 12 Maveston Street, Burwood.

The Petitioner's solicitors are Messrs Fizelle Turnbull & Co. of 224 Queen Street, Melbourne.

FIZELLE TURNBULL & CO.

NOTE—Any person who intends to appear on the hearing of the said petition must serve on or send by post to the above named solicitors notice in writing of his intention so to do. The notice must state the name and address of the person, or, if a firm, the name and address of the firm, and must be signed by the person or firm, or his or their solicitor (if any), and must be served, or, if posted must be sent by post in sufficient time to reach the above named not later than four o'clock in the afternoon of 17 June 1981. 3020

**Companies Act 1961, Section 272 (2)
FASHION FLOORS PTY. LTD. (IN LIQUIDATION)**

NOTICE OF FINAL MEETING

Notice is hereby given that pursuant to Section 272 (2) of the Companies Act 1961 a final meeting of the company and its creditors will be held at the offices of Neville Bird, Chartered Accountant, 3rd Floor, 3 Bowen Crescent, Melbourne, 3004, on Wednesday 3 June 1981, at 10.30 a.m. for the purpose of laying before the meeting an account showing how the winding up has been conducted and the property of the company has been disposed of and giving any explanation thereof.

Dated 11 May 1981

NEVILLE BIRD, Liquidator

Neville Bird, chartered accountant, 3 Bowen Crescent, Melbourne, 3004, telephone 267 5111 3004

Companies Act 1961, Section 254 (2) (b)

ROYSTON HOLDINGS PROPRIETARY LIMITED (IN LIQUIDATION)

**SIDINVEST PROPRIETARY LIMITED (IN LIQUIDATION)
MEMBERS' VOLUNTARY WINDING UP**

Notice is hereby given that at Extraordinary General Meetings of the Members of the abovenamed companies duly convened and held on 12 May 1981, it was resolved that the following resolution was passed as a Special Resolution in respect of both the abovenamed companies:

"That the company be wound up voluntarily and that the Liquidator be given such power as he deems necessary when making distribution of assets in specie to shareholders in the company."

Notice is also given that 21 days from this date I shall proceed to distribute the assets. All creditors having any claims against the company(s) should furnish particulars of same by that date, otherwise I shall proceed to distribute the assets without regard to their claim.

Dated 14 May 1981

C. S. WIGHT, Liquidator

Arthur Young & Company, 500 Bourke Street, Melbourne, Vic., 3000 3023

The Companies Act 1961—In the matter of CRANBOURNE FARMS PTY. LTD.—Members' Winding Up

Notice is hereby given that at the Extraordinary General Meeting of Cranbourne Farms Pty. Ltd. duly convened and held at 461 Bourke Street, Melbourne, 3000 in the State of Victoria on 12 May 1981 the following Resolution was proposed and passed as a Special Resolution.

"That the company be wound up voluntarily."

Dated 18 May 1981

R. F. HUGHES, Liquidator

R. F. Hughes, chartered accountant, 461 Bourke Street, Melbourne, Vic. 3000 3052

Companies Act 1961, Section 272

JAGMUT NOMINEES PTY. LTD. (IN LIQUIDATION)

NOTICE OF FINAL MEETING OF MEMBERS

Notice is hereby given that a meeting of members of Jagmut Nominees Pty. Ltd. (in Liquidation) will be held at 351 Collins Street, Melbourne (19th Floor) on 18 June 1981 at 12.00 noon.

Agenda

To lay before the meeting the Liquidator's account showing how the winding up has been conducted and the property of the company has been disposed of, and to give any explanation of the account which may be required.

Dated 18 May 1981

3033

D. O. OLDFIELD, Liquidator

CAMED DEVELOPMENT PTY. (IN VOLUNTARY LIQUIDATION)

Notice is hereby given that the Final Meeting of the Shareholders of Camed Development Pty. (in Voluntary Liquidation) will be held at 4th Floor, 691 Burke Road, Camberwell at 3.00 p.m. on Friday, 19 June 1981 for the purpose of laying before the Meeting an account showing how the Winding Up has been conducted and the property of the Company disposed of and giving any explanation thereof.

Dated 11 May 1981

3034

BARRY GARNHAM, Liquidator

The Companies Act 1961-1979

NOTICE OF FINAL MEETING

Take notice that the liquidator of H.J.A. Pty. Ltd. has called a meeting of H. J. A. Pty. Ltd. for 12 June 1981, at 10.00 o'clock in the forenoon to be held at the offices of Ahern, Betar & Dunn, 4th Floor, Reserve Bank Building, King George Square, Adelaide Street, Brisbane.

AHERN, BETAR & DUNN, agents for the liquidator

3035

PRESTON AND DISTRICT No. 5 CO-OPERATIVE HOUSING SOCIETY LIMITED (IN LIQUIDATION)

Take notice that the affairs of the above-named Society are now fully wound up and that in pursuance of section 272 (1) of the Companies Act 1961 and of the Co-operative Housing Societies Act 1958, a General Meeting of the Society will be held at the Society's Office, 505 Little Collins Street, Melbourne on 25 June 1981 at 5.30 p.m. for the purpose of—

- (i) laying before it an account showing how the winding up has been conducted and the property of the Society disposed of and giving any explanations thereof; and
- (ii) passing a resolution that the books and papers of the said Society and of the Liquidator relevant to the affairs of the Society be destroyed after a period of twelve months from the date of the meeting.

Dated 19 May 1981

3036

L. A. STEPHENSON, Liquidator
R. J. ANDERSON, Liquidator

HENRI ACCEPTANCE COMPANY PTY. LTD.

SPECIAL RESOLUTION TO WIND UP, PURSUANT TO SECTION 254 OF THE COMPANIES ACT 1961

At an Extraordinary General Meeting of the abovenamed Company, duly convened and held at 2 Endeavour Crescent, Westmeadows on 14 May 1981, the following resolution was duly passed as a Special Resolution—

"That, in accordance with the provisions of Section 254 of the Companies Act 1961, the Company be wound up voluntarily."

And at such last mentioned meeting, Anthony Macavoy Locke and John James Templeton both of First Floor, 460 Bourke Street, Melbourne were appointed Liquidators for the purpose of winding up.

Dated 14 May 1981

3039

In the matter of the Companies Act 1961; and in the matter of J. & S. ASSETS PROPRIETARY LIMITED (in Liquidation)

Notice is hereby given that pursuant to Section 272 of the Companies Act 1961, the final meeting of the members and creditors of the Company will be held at 5 Templestowe Road, Bulleen on 22 June 1981, at 10.00 a.m., for the purpose of laying before the meeting the account of the winding up and any explanation thereof.

Dated 15 May 1981

3046

J. H. REED, Liquidator

FASHION PRINT PTY. LIMITED (IN VOLUNTARY LIQUIDATION)

SPECIAL RESOLUTION TO WIND UP

At an Extraordinary General Meeting of the abovenamed company duly convened and held at 39 Reigate Road, Highton, Victoria on 15 May 1981 the following Resolution was passed as a Special Resolution:

"That the company be wound up voluntarily."

At the abovementioned meeting David Nelson was appointed Liquidator for the purpose of the winding up.

"Notice is also given that after 30 days from this date, I shall proceed to distribute the assets. All creditors having any claim against the company should furnish particulars of same by that date, otherwise I shall proceed to distribute the assets without regard to their Claim."

Dated 16 May 1981

D. NELSON, liquidator, 39 Reigate Road, Highton, Vic., 3216

3040

The Companies Act 1961

ESTRO PTY. LTD. (IN VOLUNTARY LIQUIDATION)

NOTICE CONVENING FINAL MEETING OF MEMBERS, PURSUANT TO SECTION 272

Notice is hereby given in pursuance of Section 272 of the Companies Act 1961, that a Meeting of Members of the abovenamed Company will be held at the office of Deloitte Haskins & Sells, 6th Floor, 461 Bourke Street, Melbourne on Monday, 22 June 1981 at 10.00 a.m. for the purpose of having an account laid before them showing the manner in which the winding up has been conducted and the property of the company disposed of and of hearing any explanations that may be given by the liquidator.

Dated 15 May 1981

K. W. BROWN, Liquidator

Deloitte Haskins & Sells, chartered accountants, 461 Bourke Street, Melbourne, Vic., 3000

3044

The Companies Act 1961

GALLI CONTRACTING PTY. LTD. (IN LIQUIDATION)

NOTICE CONVENING FINAL MEETING OF THE COMPANY, PURSUANT TO SECTION 272 (1)

Notice is hereby given that the Final Meeting of Members of the abovenamed Company will be held at the offices of Touche Ross & Co., 12th Floor, 440 Collins Street, Melbourne on 23 June 1981 at 10.30 a.m. for the purpose of laying before the Meeting an account showing how the winding up has been conducted and the property of the Company has been disposed of and giving any explanation thereof.

Dated 20 May 1981

G. O. HARRISON, Liquidator

Touche Ross & Co., chartered accountants, 440 Collins Street, Melbourne, 3000

3045

In the matter of the Companies Act 1961; and in the matter of TIMSBURY PARK PASTORAL CO. PROPRIETARY LIMITED (in Liquidation)—Notice of Final Meeting of Members, Pursuant to Section 272 and Notice to Creditors to Lodge Claims

Notice is hereby given in pursuance of Section 272 of the Companies Act 1961 that a General Meeting of the members of the above company will be held at the office of Messrs Coopers & Lybrand, 18th Floor, 461 Bourke Street, Melbourne on 24 June 1981, at 10.00 o'clock in the forenoon for the purpose of having an account laid before them showing the manner in which the winding up has been conducted and the property of the company disposed of, and hearing any explanation that may be given by the liquidator.

Notice is also given that any creditors who have claims which have not yet been satisfied must lodge such claims with me prior to 10 June 1981 or be excluded from settlement.

Dated 20 May 1981

R. F. HUGHES, Liquidator

Robert Foster Hughes, chartered accountant, 15th Floor, 461 Bourke Street, Melbourne, Vic. 3000

3047

In the Supreme Court of Victoria—In the matter of the Companies Act 1961; and in the matter of L.M. SHOES PTY. LTD.

Notice is hereby given that a petition for the winding up of the abovenamed Company by the Supreme Court was on 18 May 1981 presented by Eric John Unger, Deputy Commissioner for Taxation of the Commonwealth of Australia and that the said petition is directed to be heard before the Court sitting of the Fifteenth Court, Law Courts, Lonsdale Street, Melbourne at the hour of 10.30 o'clock in the forenoon on 4 June 1981 and any creditor or contributory of the said company desiring to support or oppose the making of an order on the said petition may appear at the time of hearing by himself or his Counsel for the purpose; and a copy of the said petition will be furnished to any creditor or contributory of the said company requiring the same by the undersigned on payment of the regulated charge for the same.

The Petitioner's official address is 350 Collins Street, Melbourne.

The Petitioner's solicitor is B. J. O'Donovan, Crown Solicitor for the Commonwealth of 99 Queen Street, Melbourne.

B. J. O'DONOVAN

NOTE—Any person who intends to appear on the hearing of the said petition must serve on or send by post to the abovenamed B. J. O'Donovan, notice in writing of his intention so to do. The notice must state the name and address of the person, or, if a firm, the name and address of the firm, and must be signed by the person or firm, or his, or their solicitor (if any), and must be served, or, if posted, must be sent by post in sufficient time to reach the abovenamed not later than 4.00 o'clock in the afternoon of 3 June 1981. 3049

In the Supreme Court of Victoria—In the matter of the Companies Act 1961; and in the matter of FOURTH BERNOU PTY. LTD.

Notice is hereby given that a petition for the winding up of the abovenamed Company by the Supreme Court was on 18 May 1981 presented by Eric John Unger, Deputy Commissioner for Taxation of the Commonwealth of Australia and that the said petition is directed to be heard before the Court sitting of the Fifteenth Court, Law Courts, Lonsdale Street, Melbourne at the hour of 10.30 o'clock in the forenoon on 4 June 1981 and any creditor or contributory of the said company desiring to support or oppose the making of an order on the said petition may appear at the time of hearing by himself or his Counsel for the purpose; and a copy of the said petition will be furnished to any creditor or contributory of the said company requiring the same by the undersigned on payment of the regulated charge for the same.

The Petitioner's official address is 350 Collins Street, Melbourne.

The Petitioner's solicitor is B. J. O'Donovan, Crown Solicitor for the Commonwealth of 99 Queen Street, Melbourne.

B. J. O'DONOVAN

NOTE—Any person who intends to appear on the hearing of the said petition must serve on or send by post to the abovenamed B. J. O'Donovan, notice in writing of his intention so to do. The notice must state the name and address of the person, or, if a firm, the name and address of the firm, and must be signed by the person or firm, or his, or their solicitor (if any), and must be served, or, if posted, must be sent by post in sufficient time to reach the abovenamed not later than 4.00 o'clock in the afternoon of 3 June 1981. 3050

In the Supreme Court of Victoria—Co. 11892—In the matter of the Companies Act 1961; and in the matter of J. H. GARNET (AUST.) PTY. LTD.—Notice of Winding Up Order

Winding Up Order made 14 May 1981.

Name and address of Liquidator: David Alexander Crawford, care of Peat, Marwick, Mitchell & Co., 500 Bourke Street, Melbourne.

B. J. O'DONOVAN, Crown Solicitor for the Commonwealth and solicitor for the petitioner 3051

The Companies Act 1961

In the matter of OSMAR INVESTMENTS PTY. LTD. (in Voluntary Liquidation)

In the matter of TIQUA INVESTMENTS PTY. LTD. (in Voluntary Liquidation)

Notice is hereby given in pursuance of section 272 of the Companies Act 1961 that General Meetings of the members of the above companies will be held at the Office of Messrs Russell, Kennedy & Cook, 12th Floor, 257 Collins Street, Melbourne on 29 June 1981 at 4.30 o'clock in the afternoon in the case of Osmar Investments Pty. Ltd. (in voluntary liquidation) and 4.45 o'clock in the afternoon in the case of Tiqua Investments Pty. Ltd. (in voluntary liquidation) for the purpose of having an account laid before them showing, in the case of each Company, the manner in which the winding up has been conducted and the property of the company has been disposed of, and hearing any explanation that may be given by the Liquidators.

Dated 15 May 1981

H. SCHWARZ, Liquidator
OSHRI SCHWARZ, Liquidator

Russell, Kennedy & Cook, solicitors, 257 Collins Street, Melbourne 3048

Creditors, next of kin and others having claims in respect of the estate of Alexander David Dick Maclean late of 29 Lansell Road, Toorak, Director deceased, who died on 10 September 1980 are required to send particulars of their claims to the executor James Samuel Gibson of 303 Collins Street, Melbourne by 1 August 1981 after which date he may distribute the assets having regard only to the claims of which he then has notice.

J. S. GIBSON, solicitor, 303 Collins Street, Melbourne 2928

HENRY WATMUFF, late of 7 Farleigh Grove, Brighton, retired bank manager, DECEASED

Creditors, next of kin and others having claims in respect of the estate of the deceased who died on 16 January 1981 are required by the trustees The Perpetual Executors and Trustees Association of Australia Limited of 50 Queen Street Melbourne and Jonathan Hugh Watmuff of 8 Brixton Street Flemington Graduate Research Assistant to send particulars of their claims to the said trustees in the care of the said company within two clear months of the date of this advertisement after which date the trustees may convey or distribute the assets having regard only to the claims of which they then have notice.

D. L. McNAMARA, LL.B., solicitor, 19 Grey Street, St. Kilda 2929

Creditors, next of kin and others having claims in respect of the Estate of Jane Phoebe Manley late of 143 Woodland Street Essendon in the State of Victoria Widow deceased (who died on 7 February 1981) are required to send particulars of their claims to The Equity Trustees Executors and Agency Company Limited of 472 Bourke Street Melbourne by 15 July 1981 after which date it will distribute the assets of the deceased having regard only to the claims of which it then has notice.

DAWSON, KENNEDY & CO., solicitors, 270A Hampshire Road, Sunshine 2930

FRANK PRUSCINO, late of 56 Spring Street, Preston, in the State of Victoria, pensioner, DECEASED, intestate

Creditors, next of kin and others having claims in respect of the estate of the deceased (who died on 27 June 1979) are required by the Administratrix Giuseppina Pruscino of 7 Spring Street, Preston, Widow to send particulars to her, care of the undersigned, on or before 31 July 1981, after which date she will distribute the assets having regard only to the claims of which she then has notice.

R. P. BAYLOR & CO., solicitors, of 1 Walkers Road, Nunawading, 3131 2931

Creditors, next of kin and others having claims in respect of the estate of Gertrude Mary Day late of 6 Adeney Street North Balwyn Gentlewoman deceased who died on 25 January 1981 are required to send particulars of their claims to The Equity Trustees Executors and Agency Company Limited of 472 Bourke Street Melbourne by 27 July 1981 after which date it will distribute the assets having regard only to the claims of which it then has notice.

BEATTIE & CHAPMAN, solicitors, 270 Waverley Road, East Malvern 2932

NELLIE JEAN SHEILA FINDLAY, late of 370 Wattletree Road, East Malvern, trained nurse, DECEASED

Creditors, next of kin and others having claims in respect of the estate of the deceased who died on 13 March 1981 are required by the executor Geoffrey Henry Kirkham of "Peronne" Glasscocks Road Lyndhurst Farmer to send particulars to him care of the undersigned by 27 July 1981 after which date he may convey or distribute the assets having regard only to the claims of which he then has notice.

BEATTIE & CHAPMAN, solicitors, 270 Waverley Road, East Malvern 2933

HERBERT OSBORNE MEAD, late of 27 Wattle Street, Bendigo, retired railway employee, DECEASED

Creditors, next of kin and others having claims against the Estate of the abovenamed deceased who died on 16 February 1980 are required to send particulars thereof to National Trustees Executors and Agency Company of Australasia Limited of 46 Queen Street, Bendigo, on or before 15 July 1981 after which date the said Company will distribute the assets of the said deceased having regard only to the claims of which it then has notice.

2934

SAMUEL JOSEPH MOULD, late of 75 Sternberg Street, Bendigo, retired clerk, DECEASED

Creditors, next of kin and others having claims against the Estate of the abovenamed deceased who died on 27 October 1980 are required to send particulars thereof to National Trustees Executors and Agency Company of Australasia Limited of 46 Queen Street, Bendigo on or before 15 July 1981 after which date the said Company will distribute the assets of the said deceased having regard only to the claims of which it then has notice.

2935

Creditors, next of kin and others having claims against the estate of William Henry Barry late of 183 Raleigh Street, Thornbury, Victoria, formerly Engineer, but late Retired, deceased, who died on 11 August 1980 are required to send particulars of their claims to the Executrix of his Will, Hazel Irene Barry care of the undermentioned Solicitors before 13 August 1981 after which date the said Executrix will distribute the estate of the said deceased having regard only to the claims of which she had then notice.

VITIELLO AND TUSZYNSKI, solicitors, 99 Springvale Road, Springvale, Victoria, 3171 2936

RAYMOND CHARLES SONNBERG, late of Phillip Street, Bonnie Doon, grazier, DECEASED

Creditors, next of kin and others having claims in respect of the deceased who died on 8 August 1980 are required by his Trustees Hilda Sarah Sonnberg of Phillip Street Bonnie Doon Widow Kaye Frances Hearn of Malcolm Street Mansfield Married Woman and Raymond George Sonnberg of Main Street Mairdample Contractor to send particulars to them care of the undermentioned firm of Solicitors by 5 August 1981 after which date the Trustees may convey and distribute the assets having regard only to the claims of which they then have notice.

MESSRS MAL. RYAN, JACKSON & GLEN, 9 High Street, Mansfield, solicitors for the trustees 2952

OWEN THOMAS HIGGINS, formerly of Manangatang, but late of Begonia Private Nursing Home, 207-215 Richards Street, Ballarat, retired chemist, DECEASED

Creditors, next of kin and other persons having claims against the estate of the said deceased who died on 6 November 1980 are required to send particulars of same to the Executor Bryan William Delany in care of the undersigned on or before 24 June 1981 after which date he will distribute the assets having regard only to the claims of which he then has notice.

GERALD E. DELANY & CO., solicitors, of 185 William Street, Melbourne, 3000 2953

TANIA TALAN, late of Woodfull Road, Lower Plenty, married woman, DECEASED, intestate

Creditors, next of kin and others having claims in respect of the Estate of the deceased who died on 15 April 1979 are required by the Administrator Monia Talan of Woodfull Road Lower Plenty widower to send particulars to the undermentioned firm by 30 June 1981 after which date the said Administrator may convey or distribute the assets having regard only to the claims to which notice has by then been given.

SETON WILLIAMS & SMYTH, solicitors, 408 Collins Street, Melbourne 2954

Creditors, next of kin and others having claims against the estate of Keith Edwin McDonald late of 27 Carinya Road, Vermont in the State of Victoria, retired car cleaner deceased, who died on 22 August 1980 are required by the Administrator National Trustees Executors and Agency Company of Australasia Limited of 95 Queen Street, Melbourne in the said State to send particulars of their claims to the said Administrator by 22 July 1981 after which date the said Administrator will distribute the assets having regard only to the claims of which the said Administrator then has notice.

KEVIN POWER & CO., solicitors, 444 Burwood Highway, Wantirna South, proctor for the applicant 2955

RUBY STOLGER, late of Bendigo Home and Hospital for the Aged, Barnard Street, Bendigo, in the State of Victoria, widow, DECEASED

Creditors, next of kin and others having claim in respect of the estate of the deceased who died on 10 December 1980 are required by the executors Sandhurst and Northern District Trustees Executors and Agency Company Limited of 18 View Street, Bendigo in the said State and Donald Leslie Mahar of 41 Victoria Street, Preston in the said State bus driver to send particulars to their care of the undermentioned Solicitors by 18 July 1981 after which date they may convey or distribute the assets having regard only to the claims of which they then have notice.

R. H. SCHLEIGER & ASSOCIATES, solicitors, 33-35 Williamson Street, Bendigo 2963

WILLIAM ROBERT BALL, late of 137 Victoria Street, Warragul, farm assistant, DECEASED

Creditors, next of kin and others having claims in respect of the estate of the deceased who died on 15 January 1981 are requested by the Trustees Executors and Agency Company Limited of 401 Collins Street Melbourne to send particulars of their claims to it by 21 July 1981 after which date the Trustee may convey or distribute the assets having regard only to the claims of which it then has notice.

DUNN STRACHAN & HARDIE, solicitors, Warragul 2966

Creditors, next of kin and others having claims in respect of the Estate of Gerald Bernard Hartigan late of 13-25 Strabane Avenue Box Hill North Gentleman deceased who died on 14 February 1981 are to send particulars of their claims to Elizabeth Anne Silvers care of R. P. Barrett & Son, Solicitors, 472 Bourke Street, Melbourne on or before 24 August 1981 after which date she will distribute the assets having regard only to the claims of which she then has notice.

R. P. BARRETT & SON, solicitors, 472 Bourke Street, Melbourne 2979

GEORGE SAMUEL FIRTH, formerly of Macedon, but late of Alexander, Castlemaine, retired gardener, DECEASED

Creditors, next of kin and others having claims in respect of the estate of the said deceased who died on 5 February 1981 are required by the executors Harold Rutherford of Mount Macedon Retired and Adrian O'Connor of Unit 5/96 Locksley Road, Ivanhoe Retired to send particulars in writing to them at the office of the undersigned at Kyneton by 31 July 1981 after which date the executors may convey or distribute the assets having regard only to the claims of which they then have notice.

H. HURRY & SON, solicitors, Kyneton 2980

ROMILDA LORNA PURDUE, late of Grey Street, Murrayville, married woman, DECEASED (who died on 17 November 1980)

Creditors, next of kin and all persons having claims against the estate of the deceased are required to send particulars to the Executor The Union-Fidelity Trustee Company of Australia Limited of 101 Lydiard Street North, Ballarat on or before 21 July 1981 after which date it will distribute the assets having regard only to the claims of which it shall then have notice.

HEINZ & GORDON, solicitors, 209 Dana Street, Ballarat 2981

JEAN MAVIS CURRY CAMPBELL, also known as Jeanne Mavis Curry Campbell, late of "Fairfield Hall", 225 North Road, Caulfield, in the State of Victoria, widow

Creditors, next of kin and others having claims in respect of the estate of the deceased (who died on 17 August 1979) are required by the Perpetual Executors and Trustees Association of Australia Limited of 50 Queen Street, Melbourne, to send particulars of their claims to the said Company by 21 August 1981 after which date it will convey or distribute the assets, having regard only to the claims of which the Company then has notice.

RIGBY & FIELDING, solicitors, 4 Bank Place, Melbourne 3006

GERTRUDE ELAINE LAST, late of Unit 1, 59 Prince Street, Mornington, spinster, DECEASED

Creditors, next of kin and others having claims in respect of the estate of the deceased who died on 27 February 1981 are required by the personal representatives George Herbert O'Dell Crowther and Martin John O'Dell Armstrong both of 459 Little Collins Street Melbourne to send particulars to them by 22 July 1981 after which date the personal representatives may convey or distribute the assets, having regard only to the claims of which they then have notice.

WEIGALL & CROWTHER, of 459 Little Collins Street, Melbourne, solicitors for the estate 3007

ANNIE CECELIA BLAKE, late of 38 Kilby Road, East Kew, widow, DECEASED

Creditors, next of kin and others having claims in respect of the estate of the deceased who died on 13 February 1981 are required by the personal representative The Trustees Executors and Agency Company Limited of 401 Collins Street Melbourne to send particulars to it by 22 July 1981 after which date the personal representative may convey or distribute the assets, having regard only to the claims of which it then has notice.

WEIGALL & CROWTHER, of 459 Little Collins Street, Melbourne, solicitors for the estate 3008

ANNINA BONGIORNO, late of 17 Davis Avenue, Nhill, in the State of Victoria, widow, DECEASED

Creditors, next of kin and others having claims in respect of the estate of the deceased who died on 19 November 1980 are required by the trustee Salvatore Vincenzo Bongiorno of 135 Flinders Street Thornbury in the said State Storeman to send particulars to him care of the undersigned by 31 July 1981 after which date the trustee may convey or distribute the assets having regard only to the claims of which he then has notice.

Dated 14 May 1981

TURNER & HOBDAV, 30 Victoria Street, Nhill, solicitors for the said trustee 3009

ANNIE JOSEPHINE HANNAN, late of Flat 5; 88 Warrigull Road, Surrey Hills, home duties, DECEASED

Creditors, next of kin and others having claims in respect of the estate of the deceased who died on 30 January 1981 are required by James Allan Flack of 13 Andrew Street Horsham Farmer the legal personal representative of the deceased to send particulars of their claims to him by 31 July 1981 after which date he will convey or distribute the assets having regard only to the claims of which he then has notice.

E. P. JOHNSON & DAVIES, of 257 Collins Street, Melbourne 3010

CHRISTINA BARLOW, late of Hedley Sutton Home, 2 Gascoyne Street, Canterbury, in the State of Victoria, gentlewoman, DECEASED

Creditors, next of kin and others having claims in respect of the estate of the deceased who died on 2 February 1981 are required by the personal representatives Margaret Victoria Yoxall (in the Will called Margaret Yoxall) of Milawa, 7 Fifth Street, Hepburn Springs in the said State Widow and Robert John Yoxall of Railway Crescent, Daylesford in the said State Motor Mechanic to send particulars to them by 24 July 1981 after which date they may convey or distribute the assets, having regard only to the claims of which they then have notice.

WEIGALL & CROWTHER, of 459 Little Collins Street, Melbourne, solicitors for the estate 3011

MARY MCCUSKER, late of 57 Daley Street, Bentleigh, in the State of Victoria, widow, DECEASED

Creditors, next of kin and others having claims in respect of the estate of the abovenamed deceased who died on 29 March 1981 are required by the executor The Trustees Executors and Agency Company Limited of 401 Collins Street Melbourne to send particulars to the executor by 21 July 1981 after which date the executor may convey or distribute the assets having regard only to the claims of which it then has notice.

DAVIES CAMPBELL & PIESSE, solicitors, of 401 Collins Street, Melbourne 3012

REGINALD DUNNING, late of 25 Belmont Street, West Preston, retired, DECEASED

Creditors, next of kin and others having claims in respect of the estate of the deceased who died on 8 April 1981 are requested to send particulars of their claims to the Executrix Cora Dunning care of the undersigned Solicitor by 21 July 1981 after which date the said Executrix will proceed to distribute the Estate having regard only to the claims of which she then has notice.

MARJORY C. COATES, solicitor, of 422 Collins Street, Melbourne 3000 3013

SARAH AMELIA CRAWCOUR, late of 14 Ailsa Avenue, East Malvern, in the State of Victoria, widow, DECEASED

Creditors, next of kin and others having claims in respect of the estate of the deceased, who died on 13 November 1980 are required by the Trustees, Edwin Sydney Crawcour and Brian Marcus Robertson Benjamin both care of the undersigned Solicitors to send particulars to them by 22 July 1981 after which date the Trustees may convey or distribute the assets having regard only to the claims of which they then have notice.

PHILLIPS FOX AND MASEL, 461 Bourke Street, Melbourne 3014

Creditors, next of kin and others having claims in respect of the Estate of Tasman Charles Corbett late of 100 Raglan Street Port Melbourne Retired deceased who died on 27 March 1981 are to send particulars of their claims to Ronald William Scott and Winifred Ellen Andersen care of the undersigned by 22 July 1981 after which date they will distribute the assets having regard only to the claims of which they then have notice.

COOK & MCCALLUM, solicitors, 422 Collins Street, Melbourne 3015

CHRISTINA McBEAN RILEY, late of 402 Dandenong Road, Caulfield, in the State of Victoria, widow, DECEASED

Creditors, next of kin and others having claims in respect of the estate of the deceased, who died on 8 February 1981 are required by the trustee Margaret Lorraine Riley of 402 Dandenong Road, Caulfield in the State of Victoria Spinster to send particulars to her care of the undersigned Solicitor by 3 August 1981 after which date the trustee may convey or distribute the assets having regard only to the claims of which she then has notice.

WHITING & BYRNE, solicitors, 440 Collins Street, Melbourne 3016

FLORENCE ALLEN, late of 367 Elgar Road, Box Hill, widow, DECEASED

Creditors, next of kin and others having claim in respect of the estate of the deceased who died on 19 March 1981 are requested to send particulars of their claims to the Administratrix Ethel Birsall Thomas care of the undersigned Solicitor by 21 July 1981 after which date the said Administratrix will proceed to distribute the Estate having regard only to the claims of which she then has notice.

MARJORY C. COATES, solicitor, of 422 Collins Street, Melbourne, 3000 3017

ELLEN EVELINE PEIRCE, late of Little Sisters of the Poor, St. Georges Road, Northcote, spinster, DECEASED

Creditors, next of kin and others having claims in respect of the estate of the abovenamed deceased who died on 19 February 1981 are required to send particulars of their claim to the Executrix Margaret Mary Lennon care of the undermentioned Solicitors by 24 June 1981 after which date she will distribute the assets having regard only to the claims of which she then has notice.

HEFFEY & BUTLER, solicitors, 258 Little Bourke Street, Melbourne, 3000 3021

ELIZABETH ALLE, late of 121 Springvale Road, Nunawading, widow, DECEASED

Creditors, next of kin and others having claims in respect of the estate of the abovenamed deceased who died on 13 August 1980 are required to send particulars of their claim to the Executrix Heiga Kivi care of the undermentioned Solicitors by 24 June 1981 after which date she will distribute the assets having regard only to the claims of which she then has notice.

HEFFEY & BUTLER, solicitors, 258 Little Bourke Street, Melbourne, 3000 3022

IAN DOUGLAS WEMYSS, late of 15 Browning Street, Moonee Ponds, clerk, DECEASED, intestate

Creditors, next of kin and others having claims in respect of the Estate of the deceased who died on 18 September 1979 are required by John Edward Wilkinson and Margaret Mary Wilkinson both of 25 Matthew Flinders Avenue Endeavour Hills in the State of Victoria the lawful guardians of Melanie Jane Wemyss the daughter and only next of kin of the said deceased to send particulars to them in the care of the undermentioned Solicitors by 31 July 1981 after which date the said Executor may convey or distribute the assets having regard only to the claims of which they then have notice.

MACPHERSON AND KELLEY, solicitors, 229 Thomas Street, Dandenong 3041

VIOLET GRACE MACFARLANE, late of 35 Nixon Street, Inglewood, widow, DECEASED

Creditors, next of kin and others having claims in respect of the estate of the deceased who died on 21 January 1981, are required by the executrix Dorothy May Jensen of 35 Nixon Street, Inglewood, to send particulars to her care of the undermentioned Solicitors by 18 July 1981, after which date she may convey or distribute the assets having regard only to the claims of which she then has notice.

R. H. SCHLEIGER & ASSOCIATES, solicitors, 33-35 Williamson Street, Bendigo 3042

ALISON MARY MELBOURNE FOX, late of Unit 8, 49 Kensington Road, South Yarra, home duties, DECEASED

Creditors, next of kin and others having claims in respect of the estate of the deceased who died on 22 February 1981 are required by the personal representatives Aylwin Stuart Leslie and Norma Leslie both of 7 Stradbroke Avenue Toorak to send particulars to them by 22 July 1981 after which date the personal representatives may convey or distribute the assets, having regard only to the claims of which they then have notice.

WEIGALL & CROWTHER, of 459 Little Collins Street, Melbourne, solicitors for the estate 3054

Creditors, next of kin and others having claims in respect of the estate of Sydney James Phillips late of 76 Nicholson Street, East Brunswick in the State of Victoria formerly Purchasing Officer late Retired deceased who died on 11 April 1981 are to send particulars of their claims to The Trustees Executors and Agency Company Limited of 401 Collins Street Melbourne by 24 July 1981 after which date it will distribute the assets having regard to the claims of which it then has notice.

WILLIAM HARRISON & SON, solicitors, 405 Collins Street, Melbourne, 3000 3024

MR DANIEL ROONEY WILKINSON
4/39 DOVER STREET, FLEMINGTON, 3031

Dependants, legal personal representatives and others having claims under the Carlton and United Breweries Ltd. Employees Superannuation Scheme to the benefit on the life of the abovenamed who died on 1 May 1981 are required by the Trustees of the Scheme, Messrs Philip Renton Power, Patrick Charles Oliver Stone and Timothy Noel Plant all of 16 Bouverie Street, Carlton, Victoria to send particulars to them by 13 July 1981 after which date the Trustees may distribute the benefit, having regard only to the claims of which they then have notice.

"Dependants" within the meaning of the Trust Deed means the widow and children of the deceased and any other persons who in the opinion of the Trustees are dependent upon the deceased.

13 May 1981

2951 J. G. CROSSLAND, Secretary to the Trustees

Pursuant to the Trustee Act 1958 notice is hereby given that all persons having claims against the estate of Charles William Priestley late of 218 Nicholson Street Orbst in the State of Victoria Retired Director deceased who died on 26 November 1980 and Probate of whose Will was granted by the Supreme Court of the said State in its Probate Jurisdiction on 30 April 1981 to Mary Priestley of 218 Nicholson Street Orbst in the State of Victoria, Widow, and to the Trustees Executors and Agency Company Limited of 401 Collins Street Melbourne in the said State are hereby required to send particulars in writing of such claims to the said Mary Priestley and The Trustees Executors and Agency Company Limited at 401 Collins Street, Melbourne aforesaid on or before 13 July 1981 after which date the said Mary Priestley and The Trustees Executors and Agency Company Limited will proceed to distribute the assets of the said Charles William Priestley deceased which shall have come to their hands amongst the persons entitled thereto, having regard only to the claims of which they shall then have had notice. And notice is hereby further given that the said Mary Priestley and The Trustees Executors and Agency Company Limited will not be liable for the assets so distributed or any part thereof to any person of whose claim they shall not have had notice as aforesaid.

Dated 4 May 1981

ARNOLD BLOCH, LEIBLER & CO., of 324 Little Lonsdale Street, Melbourne, proctors for the said Mary Priestley and The Trustees Executors and Agency Company Limited 2962

Creditors, next of kin and other having claims in respect of the estate of Isla Scott formerly of 44 Blessington Street St. Kilda but late of 51 Adelaide Street Armadale Spinster deceased who died on 29 March 1981 are to send particulars of their claims to The Equity Trustees Executors and Agency Company Limited of 472 Bourke Street Melbourne by 21 July 1981 after which date it will distribute the assets having regard only to the claims of which it then has notice.

MARTIN & MARTIN, solicitors, 37 Queen Street, Melbourne 3053

Creditors and others having claims in respect of the estate of George Taylor late of 141 Station Street Carlton Retired Coppersmith deceased who died on 13 May 1980 are to send the particulars of their claims to Stanley George Taylor in care of John Wilder Darren Moses 367 Collins Street Melbourne by 31 July 1981 after which date he will distribute the assets having regard only to the claims of which he then has notice.

Dated 20 May 1981

JOHN WILDER DARREN MOSES, solicitors, of 367 Collins Street, Melbourne 3068

Trustee Act 1958

NOTICE TO CLAIMANTS

Pursuant to the *Trustee Act 1958*, creditors next of kin and all other persons having claims in respect of the estate of any deceased person named below are required to send particulars to the legal personal representative or representatives at the addresses stated, after which date the representatives will distribute the assets, having regard only to the claims of which notice has been received:—

William Thomas Barnett late of 2 Colin Street Sunshine Fitter and Turner deceased, died on 20 March 1981. Claims to the Executor John Kevin Barnett of 46 Eirene Street Yarraville by 27 July 1981—JOHN F. CARROLL, LL.B., solicitor, 4 Paisley Street, Footscray 3025

In the Supreme Court of the State of Victoria

SALE BY THE SHERIFF

On Thursday 25 June 1981 at 2.30 p.m. at the Bailiff's Office, 2nd Floor, 300 Burwood Road Hawthorn (unless process be stayed or satisfied).

All the Estate and Interest (if any) of Helen Leech (shown on Certificate of Title as Helen Margaret Leech), Married Woman of 23 Napier Street, Donald as proprietor of an estate in fee simple in the land described in Certificate of Title Volume 5091 Folio 009 upon which is erected a brick clad dwelling known as No. 23 Napier Street Donald.

Caveat Nos. G.838084 and H.92482 affect the said estate and interest.

Terms—Cash only
3055

J. GREEN, Deputy Sheriff

In the Supreme Court of the State of Victoria

SALE BY THE SHERIFF

On Thursday 25 June 1981 at 2.30 p.m. at the Bailiff's Office, 2nd Floor, 300 Burwood Road, Hawthorn (unless process be stayed or satisfied).

All the Estate and Interest (if any) of Carol McMahon (Married Woman), of 19 Learmonth Street, Moonee Ponds, as proprietor of an estate in fee simple in the land described in Certificate of Title Volume 8782 Folio 579 upon which is a vacant block of land known as No. 49 High Street Bulla.

Terms—Cash only
3056

O. V. DALY, Sheriff's Officer

In the Supreme Court of the State of Victoria

SALE BY THE SHERIFF

On Thursday, 25 June 1981 at 2.30 p.m. at the Bailiff's Office, 2nd Floor, 300 Burwood Road, Hawthorn (unless process be stayed or satisfied).

All the Estate and Interest (if any) of John Hustwaite (shown on Certificate of Title as John Francis Hustwaite), Company Director of 9 Canning Street, Carlton as proprietor of an estate in fee simple in the land described in Certificate of Title Volume 8156 Folio 169 upon which is erected a burnt out building known as No. 75-79 Webb Street Fitzroy.

Registered Mortgage Nos. H.470093 and H.470094 and Caveat No. H.466354 affect the said estate and interest.

Terms—Cash only
3057

J. GREEN, Deputy Sheriff

In the Supreme Court of the State of Victoria

SALE BY THE SHERIFF

On Thursday, 25 June 1981 at 2.30 p.m. at the Bailiff's Office, 2nd Floor, 300 Burwood Road, Hawthorn (unless process be stayed or satisfied).

All the Estate and Interest (if any) of Edna Y. Gale, accountant (shown on Certificate of Title as Edna Yasmin Gale), of 5 Gipps Street, East Melbourne as joint proprietor with Christopher Robin Gale, student of an estate in fee simple in the land described in Certificate of Title Volume 5347 Folio 222 upon which is erected a 2 storey brick building known as No. 5 Gipps Street, East Melbourne.

Registered Mortgage No. J.253256 affects the said estate and interest.

Terms—Cash only
3058

J. GREEN, Deputy Sheriff

In the Supreme Court of the State of Victoria

SALE BY THE SHERIFF

On Thursday, 25 June 1981 at 2.30 p.m. at the Bailiff's Office, 2nd Floor, 300 Burwood Road, Hawthorn (unless process be stayed or satisfied).

All the Estate and Interest (if any) of Harilaos Doukas, machine operator and Savatoula Doukas, married woman, both of 50 Webb Street, Coburg as joint proprietors of an estate in fee simple in the land described in Certificate of Title Volume 4735 Folio 886 upon which is erected a weatherboard house known as No. 50 Webb Street, Coburg.

Registered Mortgage No. F.969651 affects the said estate and interest.

Terms—Cash only
3059

J. GREEN, Deputy Sheriff

In the Supreme Court of the State of Victoria

SALE BY THE SHERIFF

On Thursday, 25 June 1981 at 2.30 p.m. at the Bailiff's Office, 2nd Floor, 300 Burwood Road, Hawthorn (unless process be stayed or satisfied).

All the Estate and Interest (if any) of Joan Lorraine Nicholson, married woman of 2 Lillian Street, Bulleen as joint proprietor with Richard Anthony Nicholson, tailor's cutter, of an estate in fee simple in the land described in Certificate of Title Volume 8634 Folio 972 upon which is erected a brick veneer house known as No. 2 Lillian Street, Bulleen.

Registered Mortgage No. G.857580 affects the said estate and interest.

Terms—Cash only
3060

J. GREEN, Deputy Sheriff

In the Supreme Court of the State of Victoria
SALE BY THE SHERIFF

On Thursday, 25 June 1981 at 2.30 p.m. at the Bailiff's Office, 2nd Floor, 300 Burwood Road, Hawthorn (unless process be stayed or satisfied).

All the Estate and Interest (if any) of Mr W. Baddeley (shown on Certificate of Title as William Arthur Baddeley), plumber of 19 Campbell Street, Epping as proprietor of an estate in fee simple in the land described in Certificate of Title Volume 8691 Folio 933 upon which is erected a brick veneer dwelling known as No. 19 Campbell Street, Epping.

Registered Mortgage No. E.59742 affects the said estate and interest.

Terms—Cash only

3061

J. GREEN, Deputy Sheriff

In the Supreme Court of the State of Victoria
SALE BY THE SHERIFF

On Thursday, 25 June 1981 at 2.30 p.m. at the Bailiff's Office, 2nd Floor, 300 Burwood Road, Hawthorn (unless process be stayed or satisfied).

All the Estate and Interest (if any) of Alfred James Leckie, carpenter, and Loretta Josephine Leckie, married woman, both of 154 Power Street, St. Albans as joint proprietors of an estate in fee simple in the land described in Certificate of Title Volume 8338 Folio 061 upon which is erected a brick dwelling known as No. 154 Power Street, St. Albans.

Registered Mortgage Nos. H.93134, H.485858 and Caveats H.858158 and J.31450 affect the said estate and interest.

Terms—Cash only

3062

O. V. DALY, Sheriff's Officer

In the Supreme Court of the State of Victoria
SALE BY THE SHERIFF

On Thursday, 25 June 1981 at 2.30 p.m. at the Bailiff's Office, 2nd Floor, 300 Burwood Road, Hawthorn (unless process be stayed or satisfied).

All the Estate and Interest (if any) of Mr M. Di Masi (shown on Certificate of Title as Domenico Dimasi), builder of 167 Hughes Parade, Reservoir as joint proprietor with Maria Dimasi, married woman of an estate in fee simple in the land described in Certificate of Title Volume 5236 Folio 064 upon which is erected a solid brick house known as No. 167 Hughes Parade, Reservoir.

Registered Mortgage Nos. H.126426 and H.126427 affect the said estate and interest.

Terms—Cash only

3063

K. R. MARTIN, Sheriff's Officer

In the Supreme Court of the State of Victoria
SALE BY THE SHERIFF

On Thursday, 25 June 1981 at 2.30 p.m. at the Bailiff's Office, 2nd Floor, 300 Burwood Road, Hawthorn (unless process be stayed or satisfied).

All the Estate and Interest (if any) of Mr P. Mihailidis (shown on Certificate of Title as Panagiotis Mihailidis), refrigeration engineer, of 63 Bowen Street, Moonee Ponds, as joint proprietor with Parthena Mihailidis, married woman of an estate in fee simple in the land described in Certificate of Title Volume 3805 Folio 848 upon which is erected a factory known as No. 353 Victoria Street, Brunswick.

Registered Mortgage No. F.725295 affects the said estate and interest.

Terms—Cash only

3064

O. V. DALY, Sheriff's Officer

**NOTICE OF MAKING OF
STATUTORY RULES**

In pursuance of the provisions of the *Subordinate Legislation Act 1962* and the Regulations made thereunder, notice is given of the making of the following Statutory Rules:—

No.	<i>Chiropractors and Osteopaths Act 1978</i>	Price
172/1981.	Chiropractors and Osteopaths (Amendment No. 2) Regulations 1981	20c
	<i>State Electricity Commission Act 1958</i>	
173/1981.	Electrical Approvals Regulations—Proceedings of Electrical Approvals Board (Amendment) 1981	20c
	<i>Police Regulation Act 1958</i>	
174/1981.	Police (Secoded Members) Regulations 1981	20c
	<i>Public Service Act 1974</i>	
175/1981.	Public Service Amendment Regulations (No. 6) 1981	20c
	<i>Public Service Act 1974</i>	
PSD76/1981.	Public Service Amendment Determinations (No. 76) 1981	20c
PSD77/1981.	Public Service Amendment Determinations (No. 77) 1981	20c

Copies of these Statutory Rules when printed may be purchased at the Sale of Publications Branch of the Government Printing Office, located at 7A Parliament Place, Melbourne, 3002. If ordered by mail, remittance should be addressed to "The Government Printer, Box 203, P.O., North Melbourne, 3051", and should include 50c delivery and handling fee.

The annual subscription rates for Statutory Rules for the year commencing 1 January 1981, payable in advance, are as follows:—

*Statutory Rules (other than Public Service Determinations), Pamphlet copies only	\$42.00
Public Service Determinations	\$30.00
* The Bound Volume of Statutory Rules is not included in the subscription rate.	

F. D. ATKINSON
Government Printer

STATE ACTS, 1980

Copies of the following Acts of the Parliament of Victoria may be obtained at the Government Printing Office, Sale of Publications Branch, 7A Parliament Place, Melbourne, phone 651 2754 or 651 2759, or from any accredited agent, at the price set opposite to each.

A delivery and handling fee must be added to your remittance when ordering by mail as follows:

<i>Total Value of Acts Ordered</i>	<i>Delivery and Handling Fee</i>
10c—\$2.00	0.50c
\$2.05—\$5.00	\$1.00
\$5.05—\$20.00	\$1.50
Above \$20.00	\$2.00

Bound Volumes of 1979 State Acts (\$22.00) and the Index to the Bound Volumes (\$10.00) are also available.

The annual subscription rate for State Acts for the year commencing 1 January 1981 is \$37.

No.	Price
9366. Constitutional Powers (Coastal Waters)	20c
9367. Parliamentary Committees (Public Bodies Review)	40c
9368. Agricultural Chemicals	\$0.50

STATE ACTS, 1980—continued		STATE ACTS, 1980—continued	
No.	Price	No.	Price
9369. Central Gippsland (Brown Coal Land Compensation)	\$0.20	9442. Market Court (Amendment)	40c
9370. Motor Car (Payments by Pensioners)	\$0.20	9443. Appropriation (1980-81, No. 1)	\$5.25
9371. Navigable Waters (Oil Pollution) (Amendment)	\$0.20	9444. Port of Melbourne Authority (Amendment)	20c
9372. Workers Compensation (General Amendment)	\$0.20	9445. Stamps (Amendment No. 2)	20c
9373. Extractive Industries (Amendment)	\$0.30	9446. Public Authorities (Contributions) (Amendment)	20c
9374. Health (Special Accommodation Houses)	\$0.20	9448. Transport Works and Services	20c
9375. Cancer (Amendment)	\$0.20	9447. Criminal Injuries Compensation (Amendment)	20c
9376. Victorian Film Corporation (Amendment)	\$0.30	9449. Youth, Sport and Recreation (Agreements)	20c
9377. Railways (Bridges)	\$0.10	9450. Victorian Government Travel Authority (Amendment)	20c
9378. Wangerrip (Land Exchange)	\$0.20	9451. Health Commission (Amendment)	20c
9379. Supply (1980-81, No. 1)	\$0.30	9452. Old Colonists' Association (Borrowing Powers)	20c
9380. Crown Land (Mineral Springs)	\$0.20	9453. Nurses (Amendment)	20c
9381. Groundwater (Mineral Water)	\$0.20	9454. Supreme Court (Criminal Appeals)	20c
9382. Melbourne Underground Rail Loop (Land Development)	\$0.30	9455. Land Tax	40c
9383. Chiropodists (Amendment)	\$0.10	9456. Agriculture Acts (Repeal)	20c
9384. Youth, Sport and Recreation (Guarantees)	\$0.20	9457. Swine Compensation (Partial Suspension)	20c
9385. Pensioners' Rates Remission	\$0.30	9458. State Bank	20c
9386. Motor Car Traders (Amendment)	\$0.40	9459. Building Societies (Claims on Liquidation)	20c
9387. Victorian Solar Energy Council	\$0.30	9460. Superannuation	40c
9388. Racing (Amendment)	\$0.20	9461. State Forests Works and Services	20c
9389. Country Fire Authority (Amendment)	\$0.20	9462. Attorney-General and Solicitor-General	20c
9390. Local Government (Validation)	\$0.10	9463. Railway Construction and Property (Amendment)	20c
9391. Professional Boxing Control (Amendment)	\$0.10	9464. Forests (Penalties)	20c
9392. Police Regulation (Retired Police Reserve)	\$0.10	9465. Institute of Educational Administration	50c
9393. Local Authorities Superannuation (Amendment)	\$0.30	9466. Public Service (Amendment)	20c
9394. Water (Valuation Equalization)	\$0.20	9467. Marine (Amendment)	20c
9395. Upper Yarra Valley and Dandenong Ranges Authority (Amendment)	\$0.20	9468. Judges' Salaries and Pensions	40c
9396. Dog (Amendment)	\$0.20	9469. Police Regulation (Amendment)	\$0.20
9397. Hospitals Superannuation (Amendment)	\$0.20	9470. Labour and Industry (Amendment)	\$0.20
9398. Hospitals and Charities (Appointment of Administrators)	\$0.10	9471. Sale of Land (Deposits Amendment)	\$0.40
9399. Home Finance (Borrowing Powers)	\$0.20	9472. Liquor Control (Fees)	\$0.40
9400. State Employees Retirement Benefits (Amendment)	\$0.30	9473. Racing (Further Amendment)	\$0.50
9401. Wodonga Area Land Acquisition (Validation)	\$0.30	9474. Charlton (Land Exchange)	\$0.40
9402. Local Government (General Amendment)	\$0.40	9475. Public Lands and Works (Amendment)	\$0.20
9403. Motor Registration	\$0.50	9476. Parliamentary Committees	\$0.40
9404. Epworth Hospital	\$0.50	9477. Motor Car (Miscellaneous Provisions)	\$0.20
9405. Archaeological and Aboriginal Relics Preservation (Amendment)	\$0.20	9478. State Employees Retirement Benefits (Eligibility)	\$0.40
9406. Geelong Performing Arts Centre Trust	\$0.40	9479. Health (Reporting to Parliament)	\$0.40
9407. Imperial Law Re-enactment	\$0.30	9480. Mildura Irrigation and Water Trusts	\$0.40
9408. Constitutional Powers (Request)	\$0.20	9481. Protection of Animals	\$0.20
9409. Friendly Societies (Benefits)	\$0.10	9482. Forests (Australian Newsprint Mills Limited)	\$0.50
9410. Magistrates' Courts (Jurisdiction)	\$0.10	9483. Egg Industry Stabilization (Amendment)	\$0.20
9411. Baker Medical Research Institute	\$0.50	9484. Labour and Industry (Lifting of Weights)	\$0.20
9412. Protection of Animals (Amendment)	\$0.30	9485. Post-Secondary Education Remuneration Tribunal	\$0.50
9413. Stamps (Amendment)	\$0.40	9486. Subordinate Legislation (Amendment)	\$0.20
9414. Liquefied Petroleum Gas Subsidy	\$0.30	9487. Port Phillip Authority (Amendment)	\$0.50
9415. Revocation and Excision of Crown Reservations	\$0.30	9488. Country Fire Authority (Penalties)	\$0.20
9416. Forests (Amendment)	\$0.20	9489. Teaching Service (Amendment)	\$0.20
9417. Forests (Further Amendment)	\$0.20	9490. Water (Amendment)	\$0.40
9418. Transport (Road Funds)	\$0.20	9491. Sewerage Districts (Rebates)	\$0.20
9419. Building Societies (Amendment)	\$0.60	9492. Patriotic Funds (Amendment)	\$0.20
9420. Legal Profession Practice (Leo Cussen Institute)	\$0.10	9493. Coroners (Amendment)	\$0.20
9421. Instruments (Powers of Attorney)	\$0.30	9494. Cancer (Cancer Reporting)	\$0.20
9422. Melbourne (Yarra Park) Land	\$0.20	9495. Mildura College Lands (Easements)	\$0.20
9423. Sale of Land (Deposits)	\$0.20	9496. Liquor Control (Amendment)	\$1.25
9424. Post-Secondary Education (Amendment)	\$0.60	9497. Educational Grants (Continuation)	\$0.20
9425. Town and Country Planning (Amalgamation)	\$0.90	9498. Community Welfare Services (Extradition)	\$0.20
9426. Imperial Acts Application	\$1.00	9499. Court Security	\$0.20
9427. Statute Law Revision	\$0.80	9500. Estate Agents (Amendment)	\$0.40
9428. Estate Agents	\$1.60	9501. Fisheries (Amendment)	\$0.40
9429. Cattle Compensation (Amendment)	\$0.10	9502. Stamps (Amendment No. 3)	\$0.40
9430. The Bank of Adelaide (Merger)	\$0.30	9503. Road Traffic (Amendment)	\$0.20
9431. Cemeteries (Amendment)	\$0.20	9504. Public Works and Services	\$0.40
9432. Parliamentary Salaries and Superannuation	\$0.10	9505. Wildlife (Amendment)	\$0.50
9433. Police Regulation (Charges and Appeals)	\$0.20	9506. Valuation of Land (Interest Rate)	\$0.20
9434. Alcoa (Portland Aluminium Smelter)	\$0.40	9507. Water Supply Works and Services	\$0.60
9435. Educational Institutions (Guarantees) (Amendment)	20c	9508. Hairdressers Registration (Amendment)	\$0.40
9436. Business Franchise (Tobacco) (Amendment)	40c	9509. Crimes (Sexual Offences)	\$0.85
9437. Country Roads (Road Marking)	20c	9510. Adoption of Children (Information)	\$0.60
9438. Victorian Film Corporation (Commencement)	20c	9511. Transport (Deregulation)	\$0.85
9439. Gift Duty (Amendment)	20c	9512. Planning Appeals Board	\$1.45
9440. Pay-roll Tax	40c	9513. West Gate Bridge Authority	\$0.85
9441. Probate Duty	20c	9514. Residential Tenancies	\$1.95

STATE ACTS, 1981

Copies of the following Acts of the Parliament of Victoria may be obtained at the Government Printing Office, Sale of Publications Branch, 7A Parliament Place, Melbourne, phone 651 2754 or 651 2759, or from any accredited agent, at the price set opposite to each.

A delivery and handling fee must be added to your remittance when ordering by mail as follows:—

Total Value of Acts Ordered	Delivery and Handling Fee
10c—\$2.00	0.50c
\$2.05—\$5.00	\$1.00
\$5.05—\$20.00	\$1.50
Above \$20.00	\$2.00

Also available are—

Bound Volumes	\$22
Index to the Bound Volumes	\$10

No.	Price
9515. Sewerage Districts (Amendment) ..	\$0.20
9516. Dandenong Valley Authority (Amendment) ..	\$0.20
9517. Latrobe Valley (Amendment) ..	\$0.40
9518. Fisheries (Commonwealth—State Arrangements) ..	\$0.40
9519. Summary Offences (Corporation Meetings) ..	\$0.20
9520. Magistrates (Summary Proceedings) ..	\$0.20
9521. Police Offences (Restricted Publications) ..	\$0.20
9522. Business Names (Amendment) ..	\$0.50
9523. Melbourne Underground Rail Loop (Amendment) ..	\$0.20
9524. Industrial Relations ..	\$0.20
9525. Local Government (City of Melbourne) ..	\$0.40
9526. Flemington Land ..	\$0.20
9527. Police Regulation (Appointments) ..	\$0.20
9528. Land (Amendment) ..	\$0.20
9529. Liquid Petroleum Gas Subsidy (Amendment) ..	\$0.20
9530. Revocation and Excision of Crown Reservations ..	\$0.40
9531. State Electricity Commission (Amendment) ..	\$0.20

ACTS REPRINTED IN ACCORDANCE WITH THE AMENDMENTS INCORPORATION ACT 1958 (No. 6422), AND FOR SALE AS STOCKS ARE AVAILABLE AT THE SALE OF PUBLICATIONS BRANCH OF THE GOVERNMENT PRINTING OFFICE, 7A PARLIAMENT PLACE, MELBOURNE, 3002.

A delivery and handling fee must be added to your remittance when ordering by mail as follows:—

Total Value of Acts Ordered	Delivery and Handling Fee
10c—\$2.00	0.50c
\$2.05—\$5.00	\$1.00
\$5.05—\$20.00	\$1.50
Above \$20.00	\$2.00

No.	Price
8404. Abattoir and Meat Inspector (First Reprint—Incorporating amendments up to No. 9005) ..	\$1.10
6189. Acts Interpretation (Fifth Reprint—Incorporating amendments up to Act No. 9229) ..	\$0.70
6191. Administration and Probate Act 1958 (Fifth Reprint—Incorporating amendments up to No. 9075) ..	\$1.05
7147. Adoption of Children (First Reprint—Incorporating amendments up to Act No. 8602) ..	\$1.00
6257. Agricultural Chemicals Act 1958—(Third Reprint—Incorporating amendments up to Act No. 9368) ..	\$1.00
6194. Agricultural Colleges (First Reprint—Incorporating amendments up to No. 7302) ..	\$0.15
7772. Alcoholic and Drug-Dependent Persons Act 1968 (First Reprint—Incorporating amendments up to Act No. 9023) ..	\$0.60

ACTS REPRINTED IN ACCORDANCE WITH THE AMENDMENTS INCORPORATION ACT 1958 (No. 6422)—continued

No.	Price
6198. Anzac Day (First Reprint—Incorporating amendments up to No. 8344) ..	\$0.15
7117. Appeal Costs Fund Act 1964 (Second Reprint—Incorporating amendments up to No. 8145) ..	\$0.35
8273. Archaeological and Aboriginal Preservation Act 1972 (First Reprint—Incorporating amendments up to Act No. 9019) ..	\$0.30
6201. Architects (First Reprint—Incorporating amendments up to No. 8077) ..	\$0.30
6202. Auction Sales (First Reprint—Incorporating amendments up to No. 8490) ..	\$0.60
6203. Audit (Second Reprint—Incorporating amendments up to No. 8513) ..	\$1.20
9008. Bail Act 1977 (First Reprint—Incorporating amendments up to Act No. 9158) ..	\$0.70
6206. Barley Marketing (First Reprint—Incorporating amendments up to No. 9005) ..	\$0.30
6208. Benefit Associations (First Reprint—Incorporating amendments up to No. 6961) ..	\$0.65
8004. Boilers and Pressure Vessels Act 1970—(Second Reprint—Incorporating amendments up to Act No. 9019) ..	\$0.65
6529. Bread Industry Act 1959 (Second Reprint—Incorporating amendments up to Act No. 8542) ..	\$0.20
6973. Building Contracts (Deposits) Act 1962 (Second Reprint—Incorporating amendments from No. 8938) ..	\$0.20
8693. Building Industry Long Service Leave (First Reprint—Incorporating Amendments up to No. 9122) ..	\$0.85
8597. Business Franchise (Tobacco) Act 1974 (First Reprint—Incorporating amendments up to No. 9301) ..	\$0.70
6853. Business Names Act 1962 (First Reprint—Incorporating amendments up to Act No. 9427) ..	\$0.90
6213. Cancer Act 1958 (Second Reprint—Incorporating amendments up to No. 9023) ..	\$1.10
6214. Carriers and Innkeepers (Second Reprint—Incorporating amendments up to No. 8534) ..	\$0.20
6217. Cemeteries Act 1958 (Second Reprint—Incorporating amendments up to Act No. 9052) ..	\$0.90
8477. Children's Court Act 1973 (Second Reprint—Incorporating amendments up to Act No. 9008) ..	\$1.30
6220. Clean Air (Third Reprint—Incorporating amendments up to No. 8324) ..	\$0.15
4597. Closer Settlement Act 1980 (First Reprint—Incorporating amendments up to Act No. 9212) ..	\$1.20
8661. Cluster Titles Act 1974 (First Reprint—Incorporating amendments up to Act No. 9128) ..	\$0.85
6221. Coal Mines (Second Reprint—Incorporating amendments up to No. 8953) ..	\$2.15
6222. Commercial Goods Vehicles (Third Reprint—Incorporating amendments up to No. 8525) ..	\$0.55
6223. Commonwealth Arrangements (First Reprint—Incorporating amendments from No. 7809) ..	\$0.10
8089. Community Welfare Services Act 1970 (First Reprint—Incorporating amendments up to No. 8821) ..	\$1.90
6839. Companies (Sixth Reprint—Incorporating amendments up to No. 8788) ..	\$9.60
8750. Constitution Act 1975 (Third Reprint—Incorporating amendments up to Act No. 9251) ..	\$1.30
6224. Constitution Act Amendment Act 1959 (Second Reprint—Incorporating amendment up to No. 9216) ..	\$3.00
8276. Consumer Affairs Act 1972 (Fourth Reprint—Incorporating amendments up to Act No. 9197) ..	\$1.50
6225. Co-operation Act 1958 (Fourth Reprint—Incorporating amendments up to Act No. 9136) ..	\$1.60

ACTS REPRINTED IN ACCORDANCE WITH THE AMENDMENTS
INCORPORATION ACT 1958 (No. 6422)—*continued*

No.	Price
6226. Co-operative Housing Societies Act 1958 (Third Reprint—Incorporating amendments up to No. 9206) ..	\$1.50
6227. Coroners (Second Reprint—Incorporating amendments up to No. 8184) ..	\$0.35
6228. Country Fire Authority (Third Reprint—Incorporating amendments up to No. 8813) ..	\$1.25
6229. Country Roads Act 1958 (Fifth Reprint—Incorporating amendments up to No. 9212) ..	\$2.00
6230. County Court (Fourth Reprint—Incorporating amendments up to No. 9075) ..	\$0.95
6231. Crimes Act 1958 (Seventh Reprint—Incorporating amendments up to Act No. 9427) ..	\$3.90
6232. Crown Proceedings (Second Reprint—Incorporating amendments up to No. 8731) ..	\$0.40
7060. Dandenong Valley Authority Act 1963 (Second Reprint—Incorporating amendments up to Act No. 9172) ..	\$1.20
8383. Decentralized Industry Incentive Payments (First Reprint—Incorporating Amendments up to No. 8751) ..	\$0.20
6235. Dietitians Registration (First Reprint—Incorporating amendments up to No. 6886) ..	\$0.20
4989. Discharged Servicemen's Preference Act 1943 (Second Reprint—Incorporating amendments up to No. 7991) ..	\$0.20
6815. Disposal of Uncollected Goods Act 1961 (Second Reprint—Incorporating amendments up to No. 8246) ..	\$0.40
8079. Dog Act 1970 (First Reprint—Incorporating amendments up to No. 8664) ..	\$0.30
6237. Drainage Areas Act 1958 (Second Reprint—Incorporating amendments up to Act No. 8811) ..	\$0.75
8811. Drainage of Land Act 1975 (First Reprint—Incorporating amendments up to Act No. 9512) ..	\$1.20
6239. Dried Fruits Act 1968 (First Reprint—Incorporating amendments up to No. 7337) ..	\$0.25
6240. Education Act 1958 (Third Reprint—Incorporating amendments up to Act No. 9248) ..	\$1.50
6241. Electric Light and Power Act 1958 (Second Reprint—Incorporating amendments up to Act No. 9296) ..	\$1.10
8056. Environment Protection Act 1970 (Third Reprint—Incorporating amendments up to Act No. 9098) ..	\$0.95
6244. Essential Services (First Reprint—Incorporating amendments up to No. 8353) ..	\$0.20
6245. Estate Agents—(Fifth Reprint—Incorporating amendments up to No. 8490) ..	\$0.85
6246. Evidence Act 1958 (Sixth Reprint—Incorporating amendments up to Act No. 9230) ..	\$1.60
6715. Explosives Act 1960 (First Reprint—Incorporating amendments up to Act No. 8920) ..	\$1.10
7499. Extractive Industries Act 1966 (Third Reprint—Incorporating amendments up to No. 8647) ..	\$0.45
7274. Farm Produce Merchants and Commission Agents Act 1965 (First Reprint—Incorporating amendments up to No. 9075) ..	\$1.60
7733. Fences Act 1968 (Second Reprint—Incorporating amendments up to Act No. 9019) ..	\$0.70
6468. Filled Milk (First Reprint—Incorporating amendments up to No. 6886) ..	\$0.15
6251. Firearms (Fifth Reprint—Incorporating amendments up to No. 8427) ..	\$1.40
7780. Fisheries Act 1968 (First Reprint—Incorporating amendments up to No. 8694) ..	\$1.05
6916. Foreign Judgments Act 1962 (First Reprint including amendments made by No. 7332) ..	\$0.15
6585. Forests (Pulpwood Agreement) (Incorporating amendments up to No. 6886) ..	\$0.15
6254. Forests Act 1958 (Third Reprint—Incorporating amendments up to Act No. 9427) ..	\$1.90
6255. Friendly Societies Act 1958 (Second Reprint—Incorporating amendments up to Act No. 9019) ..	\$1.60
6256. Fruit and Vegetables (First Reprint—Incorporating amendments up to No. 6944) ..	\$0.30
6260. Gas and Fuel Corporation Act 1958 (Second	

ACTS REPRINTED IN ACCORDANCE WITH THE AMENDMENTS
INCORPORATION ACT 1958 (No. 6422)—*continued*

No.	Price
Reprint—Incorporating amendments up to Act No. 9255) ..	\$2.40
6262. Geelong Harbor Trust Act 1958 (Second Reprint—Incorporating amendments up to Act No. 9019) ..	\$1.40
6263. Geelong Waterworks and Sewerage (First Reprint—Incorporating amendments up to No. 7547) ..	\$0.75
8176. Gift Duty Act 1971 (First Reprint—Incorporating amendments from No. 8202) ..	\$0.55
6265. Goods (Sixth Reprint—Incorporating amendments up to No. 8425) ..	\$0.75
6266. Grain Elevators (First Reprint—Incorporating amendments up to No. 7486) ..	\$0.35
7849. Groundwater Act 1969 (Third Reprint—Incorporating amendments up to Act No. 9381) ..	\$1.20
6267. Hairdressers Registration (First Reprint—Incorporating amendments up to No. 7659) ..	\$0.30
6269. Hawkers and Pedlars (Second Reprint—Incorporating amendments up to No. 8247) ..	\$0.40
6270. Health (Third Reprint—Incorporating amendments up to No. 8506) ..	\$3.25
6531. Hire Purchase Act 1959 (Second Reprint—Incorporating amendments from No. 8232) ..	\$0.85
6933. Home Finance Act 1962 (First Reprint—Incorporating amendments up to No. 7363) ..	\$0.25
6274. Hospitals and Charities Act 1958 (Third Reprint—Incorporating amendments up to No. 9212) ..	\$1.70
6275. Housing Act 1958 (Fourth Reprint—Incorporating amendments up to Act No. 9246) ..	\$3.30
6276. Imprisonment of Fraudulent Debtors (Second Reprint—Incorporating amendments up to No. 8731) ..	\$0.55
6277. Industrial and Provident Societies Act 1958 (First Reprint)—Incorporating amendments up to Act No. 7547 ..	\$1.10
6279. Instruments Act 1958 (Sixth Reprint—Incorporating amendments up to No. 9421) ..	\$1.40
6280. Judicial Proceedings Reports (First Reprint—Incorporating amendments up to No. 7596) ..	\$0.20
7651. Juries (First Reprint—Incorporating amendments up to No. 8170) ..	\$0.55
6283. Labour and Industry Act 1958 (Seventh Reprint—Incorporating amendments up to Act No. 9163) ..	\$1.90
6284. Land Act (Fourth Reprint—Incorporating amendments up to No. 9212) ..	\$4.40
6534. Land Settlement Act 1959 (First Reprint—Incorporating amendments up to No. 7328) ..	\$0.30
6289. Land Tax Act 1958 (Third Reprint—Incorporating amendments to Act No. 9190) ..	\$1.40
6285. Landlord and Tenant (Fourth Reprint—Incorporating amendments up to No. 8208) ..	\$1.90
6286. Lands Compensation Act (Third Reprint—Incorporating amendments up to No. 8899) ..	\$0.45
6290. Latrobe Valley (First Reprint—Incorporating amendments up to No. 7332) ..	\$0.35
6291. Legal Profession Practice Act 1958. (Fifth Reprint—Incorporating amendments up to Act No. 9427) ..	\$2.40
6292. Libraries (First Reprint—Incorporating amendments up to No. 7364) ..	\$0.15
7629. Lifts and Cranes Act 1967 (Second Reprint—Incorporating amendments up to Act No. 9236) ..	\$0.90
6295. Limitation of Actions (Third Reprint—Incorporating amendments up to No. 8300) ..	\$1.60
7695. Liquor Control Act 1968 (Fourth Reprint—Incorporating amendments up to Act No. 9225) ..	\$2.40
7145. Litter Act 1964 (Third Reprint—Incorporating amendments up to Act No. 9080) ..	\$0.40
6298. Local Authorities Superannuation Act 1958 (Third Reprint—Incorporating amendments up to Act No. 9393) ..	\$1.50
6479. Local Government Department Act 1958 (First Reprint—Incorporating amendments up to Act No. 8656) ..	\$0.10

ACTS REPRINTED IN ACCORDANCE WITH THE AMENDMENTS
INCORPORATION ACT 1958 (NO. 6422)—continued

No.	Price
6299. Local Government (Third Reprint—Incorporating amendments up to No. 8781)	\$10.90
7429. Lotteries Gaming and Betting Act 1966 (Second Reprint—Incorporating amendments up to No. 9075)	\$1.20
8184. Magistrates' Courts Act 1971 (Second Reprint)—Incorporating amendments up to No. 9427	\$1.40
8731. Magistrates (Summary Proceedings) Act 1975 (First Reprint)—Incorporating amendments up to No. 9427	\$2.40
7289. Maintenance (Second Reprint—Incorporating amendments up to No. 9019)	\$1.35
6302. Marine Act (Second Reprint—Incorporating amendments up to No. 9178)	\$2.40
6303. Marine Stores and Old Metals Act 1958 (Second Reprint—Incorporating amendments up to Act No. 8622)	\$0.65
6304. Marketing of Primary Products Act 1958 (Second Reprint—Incorporating amendments up to Act No. 8965)	\$1.50
6305. Markets Act (Second Reprint—Incorporating amendments up to No. 8247)	\$0.30
6306. Marriage Act (Third Reprint—Incorporating amendments up to Act No. 9427)	\$0.75
6309. Medical Act 1958 (Third Reprint—Incorporating amendments up to No. 8593)	\$0.45
8061. Medical Practitioner (First Reprint—Incorporating amendments up to No. 8754)	\$0.75
6310. Melbourne and Metropolitan Board of Works Act 1958 (Fifth Reprint—Incorporating amendments up to Act No. 9427)	\$3.30
6311. Melbourne and Metropolitan Tramways Act 1958 (Second Reprint—Incorporating amendments up to Act No. 8992)	\$1.45
6405. Melbourne University Act 1958 (Second Reprint—Incorporating amendments up to Act No. 9123)	\$0.85
6605. Mental Health Act 1959 (Third Reprint—Incorporating amendments up to Act No. 9023)	\$1.40
6315. Metropolitan Fire Brigades (Third Reprint—Incorporating amendments up to No. 9019)	\$0.95
6316. Mildura Irrigation and Water Trusts Act 1958 (Second Reprint—Incorporating amendments up to No. 9204)	\$2.70
6317. Milk and Dairy Supervision (Second Reprint—Incorporating amendments up to No. 8655)	\$0.85
6318. Milk Board Act 1958 (Second Reprint—Incorporating amendments up to Act No. 9238)	\$1.00
6319. Milk Pasteurization (First Reprint—Incorporating amendments up to No. 7480)	\$0.20
6320. Mines Act 1958 (Third Reprint—Incorporating amendments up to Act No. 8953)	\$2.60
6322. Ministry of Transport Act 1958 (First Reprint—Incorporating amendments up to Act No. 9345)	\$0.60
6184. Monash University (First Reprint—Incorporating amendments up to No. 7533)	\$0.30
6324. Money Lenders (Fourth Reprint—Incorporating amendments up to No. 8490)	\$0.55
8429. Motor Accidents Act 1973 (Second Reprint—Incorporating amendments up to Act No. 9427)	\$1.40
6832. Motor Boating Act 1961 (Third Reprint—Incorporating amendment up to No. 8662)	\$0.55
6325. Motor Car Act (Sixth Reprint—Incorporating amendments up to Act No. 9346)	\$3.90
8526. Municipalities Assistance Act 1973 (First Reprint)—Incorporating amendments up to Act No. 9385	\$0.20
8702. National Parks Act 1975 (First Reprint—Incorporating amendments up to Act No. 9427)	\$1.40
6705. Navigable Waters (Oil Pollution) Act 1960 (Second Reprint—Incorporating amendments up to No. 8816)	\$0.90

ACTS REPRINTED IN ACCORDANCE WITH THE AMENDMENTS
INCORPORATION ACT 1958 (NO. 6422)—continued

No.	Price
6328. Nurses Act 1958 (Fourth Reprint—Incorporating amendments up to Act No. 9059)	\$1.00
8414. Ombudsman Act 1973 (Second Reprint—Incorporating amendments up to Act No. 9256)	\$0.60
6329. Optometrists Registration Act 1958 (Second Reprint—Incorporating amendments up to Act No. 8800)	\$0.70
7727. Parliamentary Committees Act 1968 (First Reprint)—Incorporating amendments up to Act No. 9367	\$1.10
7723. Parliamentary Salaries and Superannuation (First Reprint—Incorporating amendments up to No. 8687)	\$0.35
6330. Partnership (Second Reprint—Incorporating amendments up to No. 7315)	\$0.60
6331. Patriotic Funds (First Reprint—Incorporating amendments up to No. 7338)	\$0.25
6332. Pawnbrokers Act 1958 (Second Reprint—Incorporating amendments up to No. 8181)	\$0.35
8154. Pay-Roll Tax Act 1971 (First Reprint—Incorporating amendments up to No. 9059)	\$1.15
7417. Pensions Supplementation Act 1966 (Second Reprint—Incorporating amendments up to Act No. 9358)	\$0.50
6334. Petroleum Act 1958 (Second Reprint—Incorporating amendments up to Act No. 9212)	\$1.30
6335. Petrol Pumps (Second Reprint—Incorporating amendments up to No. 7315)	\$0.15
6889. Poisons Act 1962 (Fifth Reprint—Incorporating amendments up to Act No. 9427)	\$1.70
6337. Police Offences Act 1958 (Third Reprint—Incorporating amendments up to No. 8433)	\$0.45
6338. Police Regulation (Third Reprint—Incorporating amendments up to No. 8722)	\$0.95
6340. Portland Harbor Trust Act 1958 (Second Reprint—Incorporating amendments up to Act No. 9204)	\$1.10
6312. Port of Melbourne Authority Act 1958 (Third Reprint—Incorporating amendments up to Act No. 9427)	\$2.30
7498. Port Phillip Authority Act 1966 (Second Reprint—Incorporating amendments from No. 8081)	\$0.20
6341. Pounds Act 1958 (Second Reprint—Incorporating amendments up to Act No. 9168)	\$0.60
6342. Printers and Newspapers (Second Reprint—Incorporating amendments up to No. 8556)	\$0.30
7494. Private Agents Act 1966 (Third Reprint—Incorporating amendments up to Act No. 9075)	\$1.00
6890. Probate Duty Act 1962. (Fourth Reprint)—Incorporating amendments up to Act No. 9019	\$1.15
6344. Property Law Act 1958 (Fourth Reprint—Incorporating amendments up to Act No. 9075)	\$3.00
7432. Protection of Animals (First Reprint—Incorporating Amendments Up to No. 9019)	\$0.40
6345. Public Account (Second Reprint—Incorporating amendments up to No. 9033)	\$0.40
6346. Public Authorities Marks (First Reprint—Incorporating amendments from No. 7315)	\$0.10
8656. Public Service Act 1974 (Second Reprint—Incorporating amendments up to Act No. 9248)	\$1.40
6350. Public Trustee Act 1958 (Second Reprint—Incorporating amendments up to No. 8125)	\$1.05
6353. Racing (Fourth Reprint—Incorporating amendments up to No. 8690)	\$1.55
6355. Railways Act 1958 (Second Reprint—Incorporating amendments up to Act No. 9142)	\$1.55

ACTS REPRINTED IN ACCORDANCE WITH THE AMENDMENTS INCORPORATING ACT 1958 (No. 6422)—continued

No.	Price
8407. Recreation Vehicles Act 1973 (<i>First Reprint</i> —Incorporating amendments made by Act No. 8561) ..	\$0.30
6564. Registration of Births Deaths and Marriages Act 1959 (<i>Second Reprint</i> —Incorporating amendments up to Act No. 8602) ..	\$0.70
6357. Religious Successory and Charitable Trusts Act 1958 (<i>First Reprint</i> —Incorporating amendments made by Act No. 7315) ..	\$0.75
6358. River Improvements Act (<i>Second Reprint</i> —Incorporating amendments up to No. 8967) ..	\$0.85
2596. River Murray Waters Act 1915 (<i>First Reprint</i> —Incorporating amendments up to No. 7228) ..	\$0.35
6359. Road Traffic (<i>Fifth Reprint</i> —Incorporating amendments up to No. 9424) ..	\$1.00
6360. Rural Finance (<i>First Reprint</i> —Incorporating amendments up to No. 7328) ..	\$0.15
6846. Rural Finance and Settlement Commission Act 1961 (<i>First Reprint</i> —Incorporating amendments up to No. 7332) ..	\$0.30
6917. Sale of Human Blood Act 1962 (<i>First Reprint</i> —Incorporating amendments from No. 7332) ..	\$0.10
No. 6975. Sale of Land Act 1962 (<i>Fourth Reprint</i> —Incorporating amendments up to Act No. 9471) ..	\$1.20
8146. Scaffolding Act 1971 (<i>Second Reprint</i> —Incorporating amendments up to No. 8666) ..	\$0.35
6363. Second-hand Dealers (<i>First Reprint</i> —Incorporating amendments up to No. 7529) ..	\$0.25
6367. Settled Land Act 1958 (<i>Third Reprint</i> —Incorporating amendments up to Act No. 9075) ..	\$1.50
6368. Sewerage Districts Act 1958 (<i>Third Reprint</i> —Incorporating amendments up to Act No. 9139) ..	\$1.90
6809. Sheep Owners Protection Act 1961 (<i>Third Reprint</i> —Incorporating amendments up to No. 8247) ..	\$0.20
6372. Soil Conservation and Land Utilization Act (<i>Third Reprint</i> —incorporating amendments up to No. 8432) ..	\$0.90
6373. Soldier Settlement (<i>First Reprint</i> —Incorporating amendments up to No. 7328) ..	\$0.42
6375. Stamps Act 1958 (<i>Seventh Reprint</i> —Incorporating amendments up to Act No. 9502) ..	\$4.20
8793. State Co-ordination Council 1975 (<i>First Reprint</i> —Incorporating amendments up to No. 9425) ..	\$0.40
6376. State Development Committee Act 1958 (<i>First Reprint</i> —Incorporating amendments up to No. 8827) ..	\$0.30
6377. State Electricity Commission Act 1958 (<i>Third Reprint</i> —incorporating amendments up to Act No. 9121) ..	\$1.35
6378. State Relief Committee (<i>First Reprint</i> —Incorporating amendments from No. 6886) ..	\$0.10
6379. State Savings Bank Act 1958 (<i>Third Reprint</i> —Incorporating amendments up to No. 8519) ..	\$0.95
6380. Statistics (<i>First Reprint</i> —Incorporating amendments up to No. 6961) ..	\$0.20
6877. Stock (Artificial Breeding) Act 1962 (<i>First Reprint</i> —Incorporating amendments up to No. 8709) ..	\$0.30
7724. Stock Diseases Act 1968 (<i>First Reprint</i> —Incorporating amendments up to Act No. 8775) ..	\$0.90
6383. Stock Foods (<i>First Reprint</i> —Incorporating amendments up to No. 7607) ..	\$0.28
6384. Stock Medicines Act 1958 (<i>Second Reprint</i> —Incorporating amendments up to No. 9005) ..	\$0.50
7551. Strata Titles Act 1967 (<i>Third Reprint</i> —Incorporating amendments up to No. 8661) ..	\$1.00

ACTS REPRINTED IN ACCORDANCE WITH THE AMENDMENTS INCORPORATION ACT 1958 (No. 6422)—continued

No.	Price
6886. Subordinate Legislation Act 1962 (<i>Second Reprint</i> —Incorporating amendments up to No. 8127) ..	\$0.15
7405. Summary Offences Act 1966 (<i>Second Reprint</i> —Incorporating amendments up to No. 8276) ..	\$0.55
7634. Sunday Entertainment (<i>First Reprint</i> —Incorporating amendments up to No. 8173) ..	\$0.15
6386. Superannuation Act 1958 (<i>Fourth Reprint</i> —Incorporating amendments up to No. 9125) ..	\$1.70
6387. Supreme Court (<i>Second Reprint</i> —Incorporating amendments up to No. 8951) ..	\$1.35
6388. Survey Co-ordination Act 1958 (<i>Second Reprint</i> —Incorporating amendments up to No. 9180) ..	\$0.70
6390. Tattersall Consultations (<i>Second Reprint</i> —Incorporating amendments up to No. 8982) ..	\$0.30
8274. Taxation Appeals Act 1972 (<i>First Reprint</i> —Incorporating amendments up to Act No. 9045) ..	\$0.55
6391. Teaching Service (<i>Second Reprint</i> —Incorporating amendments up to No. 8691) ..	\$0.55
6393. Theatres (<i>First Reprint</i> —Incorporating amendments up to No. 8161) ..	\$0.15
6849. Town and Country Planning Act 1961 (<i>Fifth Reprint</i> —incorporating amendments up to No. 8716) ..	\$1.25
6397. Trade Unions (<i>Second Reprint</i> —Incorporating amendments up to No. 8181) ..	\$0.40
6399. Transfer of Land Act 1958 (<i>Sixth Reprint</i> —Incorporating amendments up to Act No. 9324) ..	\$1.90
6400. Transport Regulation Act (<i>Third Reprint</i> —Incorporating amendments up to No. 8700) ..	\$0.75
6401. Trustee Act 1958 (<i>Fifth Reprint</i> —Incorporating amendments up to Act No. 9204) ..	\$1.50
6402. Trustee Companies Act 1958 (<i>Second Reprint</i> —Incorporating amendments up to Act No. 9075) ..	\$0.55
6879. Unclaimed Moneys Act 1962 (<i>Second Reprint</i> —Incorporating amendments up to No. 8448) ..	\$0.20
7095. Underseas Mineral Resources Act 1963 (<i>First Reprint</i> —Incorporating amendments from No. 7591) ..	\$0.10
6406. Unlawful Assemblies and Processions Act 1958 (<i>First Reprint</i> —Incorporating amendments up to Act No. 9019) ..	\$0.60
6653. Valuation of Land Act 1960 (<i>Fifth Reprint</i> —Incorporating amendments up to Act No. 9225) ..	\$1.10
6407. Vegetation and Vine Diseases (<i>First Reprint</i> —Incorporating amendments up to No. 7423) ..	\$0.30
6408. Venereal Diseases (<i>First Reprint</i> —Incorporating amendments made by Act No. 6886) ..	\$0.55
6409. Vermin & Noxious Weeds (<i>First Reprint</i> —Incorporating amendments up to No. 7463) ..	\$0.35
6410. Veterinary Surgeons (<i>First Reprint</i> —Incorporating amendments up to No. 7343) ..	\$0.15
7291. Victoria Institute of Colleges Act 1965 (<i>Second Reprint</i> —Incorporating amendments up to Act No. 8710) ..	\$0.90
8428. Victorian Development Corporation Act 1973 (<i>First Reprint</i> —Incorporating amendments up to Act No. 9314) ..	\$1.00
6412. Warehousemen's Liens (<i>First Reprint</i> —Incorporating amendments up to No. 7876) ..	\$0.15
6413. Water (<i>Fourth Reprint</i> —Incorporating amendments up to No. 9394) ..	\$7.40
6414. Weights and Measures Act 1958 (<i>Fourth Reprint</i> —Incorporating amendments up to Act No. 9019) ..	\$1.90
6415. Wild Flowers and Native Plants Protection (<i>First Reprint</i> —Incorporating amendments up to No. 6976) ..	\$0.15
6416. Wills Act 1958 (<i>Second Reprint</i> —Incorporating amendments up to Act No. 9075) ..	\$0.60

ACTS REPRINTED IN ACCORDANCE WITH THE AMENDMENTS
INCORPORATION ACT 1958 (No. 6422)—*continued*

No.	Price
6417. Wire Netting (<i>Second Reprint—Incorporating amendments up to No. 7876</i>)	\$0.65
6419. Workers Compensation Act 1958 (<i>Eighth Reprint—Incorporating amendments up to Act No. 9372</i>)	\$2.40
6420. Wrongs Act 1958. (<i>Third Reprint—Incorporating amendments up to Act No. 9153</i>)	\$0.60
8344. Youth, Sport and Recreation Act 1972 (<i>First Reprint—Incorporating amendments up to No. 8550</i>)	\$0.35

F. D. ATKINSON
Government Printer

2. *Other matter*

(a) All other matter duly certified by a responsible officer for publication should be lodged with the *Gazette Officer* not later than half-past Nine a.m. on Tuesday.

(b) Lengthy or involved notices should be forwarded several days before publication.

(c) Proofs, which will be supplied only when specifically requested or at the direction of the *Gazette Officer*, should be returned promptly to avoid delay in publication.

(d) No additions or amendments to matters for publication will be accepted by telephone.

CONTENTS

THE "VICTORIA GOVERNMENT GAZETTE"

PUBLICATION—A VICTORIA GOVERNMENT GAZETTE is published every WEDNESDAY EVENING unless advertised otherwise.

SUBSCRIPTIONS—The annual subscription rate, including postage, is \$72, payable in advance.

PRIVATE ADVERTISEMENTS—Advertisements will be received by the Government Printer not later than the day preceding publication—at ordinary rates at or before ONE p.m. and at double rates between ONE p.m. and HALF PAST THREE p.m. The charge for ADVERTISEMENTS is 90 cents per line single column and \$1.80 per line double column. The charge for a full page is \$135. The title forms one or more lines as a heading. On an average ten words make a line of single column. Every signature must likewise be counted as a line. The final words of a paragraph though only portion of a line, must be counted as one line. Signatures (in particular) and proper names must be written very clearly in the text; ONE SIDE ONLY of each sheet of paper should be written upon.

All documents NOT CLEARLY PREPARED will be returned unpublished. Where brands occur, not provided for by the ordinary letters of the alphabet, a written explanatory description also must be furnished.

PAYMENTS—Unless the advertiser has a Credit Account, all payments are required in advance. Remittances should be made by cheque, postal order or money order, payable to "GOVERNMENT PRINTER".

CORRESPONDENCE—All correspondence should be addressed to "The Victorian Government Printer, P.O. Box 203, North Melbourne, 3051".

PUBLICATION OF OFFICIAL MATTER

Attention is invited to the following procedure in relation to the publication of official matter in the *Government Gazette*:—

Publication will be facilitated by the submission of carbon copies for the use of the *Gazette Officer*.

1. *Matter submitted to the Executive Council*

Matter submitted to the Executive Council which requires gazettal will normally be published in the issue of the following week.

Where urgent gazettal is required, special arrangements should be made with the *Gazette Officer*, Department of the Premier, Third Floor, 1 Treasury Place, Melbourne. Telephone: 651 1706.

	Page
Acts of Parliament	1565
Acts of Parliament on Sale at the Government Printing Office	1622
Appointments	1583
Cemeteries—Scale of Fees	1577
Contracts	1581
Country Roads Board	1570
Estates of Deceased Persons	1582
Government Notices	1568
Lands	1596
Melbourne and Metropolitan Board of Works— Notice	1579
Minerals and Energy	1581
Notice of Making of Statutory Rules	1622
Orders in Council—	
Acts—Local Government; State Electricity Commission; Crown Land (Reserves); Water; Mildura Irrigation and Water Trusts; Coal Mines; Superannuation; Local Government; Crown Land (Reserves); Lands; Country Roads Board; Railway Construction and Property Board; Industrial Relations; Workers Compensation; Public Service; Forests; Films; Parliamentary Committees; Local Government	1584 et seq
Police Sale	1577
Private Advertisements	1597
Proclamations	1565
Regulations—	
Act—Teaching Service	1576
Resignations	1584
Tenders	1596
Transport Regulation Board—Public Hearings	1569

[1629]

PUBLISHED BY AUTHORITY



Victoria Government Gazette

No. 43—Friday, 22 May 1981

LEGISLATIVE ASSEMBLY

THE HONOURABLE THE MINISTER FOR PROPERTY AND SERVICES

I hereby notify that I have this day issued a Writ for the Election of a Member to serve in the Legislative Assembly of Victoria for the Electoral District of Morwell.

Date of Writ	22 May 1981
Day before or on which nominations are to be made	9 June 1981
Day of Polling	27 June 1981
Return of Writ	14 July 1981

S. J. PLOWMAN
Speaker

Legislative Assembly
Melbourne, 22 May 1981

