



Victoria Government Gazette

No. 101—Wednesday, 6 October 1982

PROCLAMATIONS

Litter Act 1964

APPLICATION OF THE PROVISIONS OF SECTION 3B TO THE MUNICIPAL DISTRICT OF THE SHIRE OF KYNETON

PROCLAMATION

By His Excellency the Governor of the State of Victoria and its Dependencies in the Commonwealth of Australia, &c., &c., &c.

Whereas by the *Litter Act 1964*, section 3b, it is provided that the Governor in Council on the application of the council of a municipality may by proclamation published in the *Government Gazette* declare that the municipal district of the municipality or any part thereof shall be a district to which the said section applies.

And whereas the Council of the Shire of Kyneton has made application to have its municipal district declared to be a district to which the said section 3b applies.

Now therefore, I, the Governor of the State of Victoria, in the Commonwealth of Australia, by and with the advice of the Executive Council of the said State do by this Proclamation declare that the municipal district of the Shire of Kyneton shall be a district to which the provisions of section 3b of the *Litter Act 1964* apply.

Given under my Hand and the Seal of the State of Victoria, aforesaid at Melbourne this twenty-eighth day of September in the year of our Lord One thousand nine hundred and eighty-two and in the thirty-first year of the reign of Her Majesty Queen Elizabeth II.

(L.S.) B. S. MURRAY

By His Excellency's Command
F. N. WILKES
Minister for Local Government
GOD SAVE THE QUEEN!

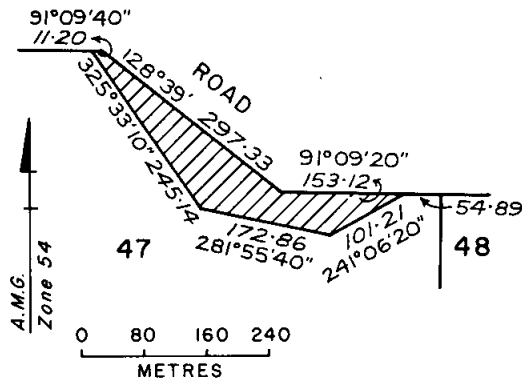

Given under my Hand and the Seal of the State of Victoria aforesaid, at Melbourne, this twenty-eighth day of September, in the year of our Lord One thousand nine hundred and eighty-two, and in the thirty-first year of the reign of Her Majesty Elizabeth the Second, Queen of Australia.

(L.S.) B. S. MURRAY

By His Excellency's Command
R. A. MACKENZIE
Minister of Lands
GOD SAVE THE QUEEN!

Land Act 1958

ROAD PROCLAIMED

PROCLAMATION

By His Excellency the Governor of the State of Victoria and its Dependencies in the Commonwealth of Australia, &c., &c., &c.

I, the Governor of the State of Victoria, in the Commonwealth of Australia, by and with the advice of the Executive Council of the said State, pursuant to the provisions of section 25 (3) (c) of the *Land Act 1958*, do hereby proclaim as road the Crown land hereinafter described, viz.:

Parish of Piangil West, being the land indicated by hatching on plan hereunder—(P.148⁽⁴⁾) (3607/155).

Land Act 1958

ROAD PROCLAIMED

PROCLAMATION

By His Excellency the Governor of the State of Victoria and its Dependencies in the Commonwealth of Australia, &c., &c., &c.

I, the Governor of the State of Victoria, in the Commonwealth of Australia, by and with the advice of the Executive Council of the said State, pursuant to the provisions of section 25 (3) (c) of the *Land Act 1958*, do hereby proclaim as road the Crown land hereinafter described, viz.:

Parish of Gobur, being the land indicated by hatching on plan hereunder—(G.188⁽⁵⁾) (Rs.11413).

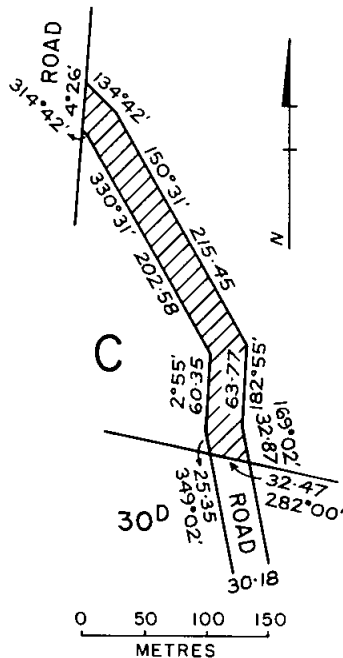

Given under my Hand and the Seal of the State of Victoria aforesaid, at Melbourne, this twenty-eighth day of September, in the year of our Lord One thousand nine hundred and eighty-two, and in the thirty-first year of the reign of Her Majesty Elizabeth the Second, Queen of Australia.

(L.S.) B. S. MURRAY
By His Excellency's Command
R. A. MACKENZIE
Minister of Lands
GOD SAVE THE QUEEN!

GOVERNMENT NOTICES

STATE RIVERS AND WATER SUPPLY COMMISSION
By-Law No. 5936

Restricting the Use of Water Within the District Supplied with Water from the Coliban System of Waterworks

The State Rivers and Water Supply Commission (hereinafter called "the Commission") pursuant to and in exercise and execution of the powers and authorities conferred on such Commission by the Water Act 1958 and in exercise and execution of any other powers and authorities in any way enabling the Commission in that behalf doth make the By-law following:

1. This By-law shall be substituted for By-law Nos. 5561, 5562 and 5563 which are hereby repealed.

2. In this By-law unless inconsistent with the subject matter or context—

"The Act" means the Water Act 1958 and any Act amending the same.

"Aqueduct" includes any race or channel vested in belonging to or under the control of the Commission and any private extension thereto used for the conveying and the supplying of water.

"Commercial and industrial garden" means any garden appurtenant to any building used for commercial or industrial purposes and includes any area within the curtilage of such building adapted for sport or recreation other than a sports ground as defined herein as well as any nature strip appurtenant to the curtilage of such building and includes for the purposes of this By-law any garden or nature strip appurtenant to any hospital home for the aged cemetery public building school college university and the like.

"Commercial poultry building" means any building in which eggs are produced or poultry is grown for profit.

"Commission district" means the district supplied with water from the Coliban System of Waterworks.

"Declare" means the bringing into operation of a period of restriction within a specified area a variation of a period of restriction within a specified area or the termination of a period of restriction within a specified area and "Declaration" has a similar meaning.

"Domestic use" in relation to water means use for household purposes or for watering animals kept for domestic purposes but does not include use for watering any other animals or any trees shrubs plants grass lawns or courts or flower garden kitchen garden or other garden whatsoever or any part of the curtilage of the house or for the provision of power or for fountains ponds or ornamental purposes or for any trade or business or for any other purpose whatsoever.

"Fixed sprinkler" and "sprinkler system" means a fixed pipe hose system device or the like used to distribute disperse sprinkle or spray water but does not include misting systems used in the commercial propagation of seeds or fogging systems used in commercial poultry industry.

"Garden" means any ground used for the cultivation of or in which are situate trees shrubs flowers vegetables lawns or vegetation of any kind.

"Main pipe" means any pipe vested in belonging to or under the control of the Commission and any private extension thereto used for the conveying and the supplying of water.

"Market garden" means any ground used wholly for the growing of any vegetables fruit seedlings seeds or flowers or other like produce for sale or in the case of a charitable institution the use thereof by such institution or by some other like institution.

"Municipal garden" means any garden controlled by a municipal council but does not include a commercial and industrial garden or a private garden or any median strip in any roadway.

"Newspaper" means "The Age" "The Herald" "The Sun" or other newspaper circulating generally within the Commission district or part thereof which has been made subject to a period of restriction.

"Nursery" means any land devoted to the cultivation of trees shrubs flowers seeds and seedlings or other like produce either for sale or distribution by some body (whether corporate or not) whether for profit or not.

"Period" means a succession of days whether broken or not commencing at a specified hour of a specified day and concluding at a specified hour on a specified day or at such hour of such day as shall subsequently be declared.

"Period of restriction" means a period in which the use of water supplied by the Commission shall not be used for any of the purposes set out in any one of the stages numbered 1 to 8 herein and which stage is declared by the Commission to come into operation for a period within the Commission district or part thereof as the Commission may from time to time specify by notice published in a newspaper circulating generally within the Commission district or part thereof as so specified.

"Private garden" means a garden appurtenant to a building used for domestic purposes and shall include any part of the curtilage in which the private garden is situate which is used or adapted for use for the purposes of any sport game or other form of recreation and any nature strip appurtenant to such curtilage.

"Specified Area" means the Commission district or part thereof supplied with water by the Commission from a main pipe or aqueduct within which a period of restriction is in operation.

"Sports ground" means any ground used or adapted for use for the purpose of any sport game contest or other form of recreation by any club school institution or like organization or by any person normally conducting any sport game contest or other form of recreation upon such ground for gain or reward but does not include such ground within the curtilage of a commercial or industrial building unless usually used for gain or reward.

"Stage" means a set of restrictions on the use of water supplied by the Commission as set out in this By-law and being any one of the stages numbered 1 to 8 herein.

"Used water" means water that has been used for some domestic, commercial or industrial purpose and cannot again be so used.

"Vehicle" includes a motor car or a trailer as defined in the *Motor Car Act 1958* and a recreation vehicle within the meaning of the *Recreation Vehicles Act 1973* and a caravan and for the purposes of this By-law shall include a boat, an aircraft, a train or a tram.

3. If in the opinion of the Commission it is necessary to reduce the consumption of water supplied by the Commission from a mainpipe or aqueduct for other than domestic purposes within the Commission district or part thereof the Commission may at any time and from time to time specify that this By-law implementing any one stage of the stages numbered 1 to 8 herein shall come into operation in respect to the Commission district or part thereof and thereupon the area so specified shall be a specified area and the use of water so supplied within that specified area shall be subject to the period of restriction thereby brought into operation and the water so supplied shall not be used for the purposes listed in the stage thereby brought into operation.

4. If in any specified area in the opinion of the Commission (having regard to the water supply then available) any other stage of the stages 1 to 8 herein should come into operation in substitution for the stage then in operation the Commission may at any time and from time to time specify that another stage shall come into operation and thereafter the use of water so supplied within that specified area shall be subject to the period of restriction thereby brought into operation and the water so supplied shall not be used for any of the purposes set forth in the stage thereby brought into operation.

5. Any declaration made pursuant to Clause 3 or Clause 4 hereof shall be published by means of a Notice in a newspaper and subject to such publication shall take effect as provided in such Notice.

6. During any period of restriction in any specified area water supplied by the Commission from a mainpipe or aqueduct other than used water shall not be used—

(1) during a period of restriction in which stage 1 has been brought into operation:

- (a) to water any private garden any commercial and industrial garden any market garden or any nursery or to cool any commercial poultry building by means of fixed sprinklers except between 6.00 a.m. and 9.00 p.m.;
- (b) to water any municipal gardens or sports ground by means of fixed spinklers except between 6.00 a.m. and 9.00 p.m. provided however that where an automatically controlled watering system has been installed 10.00 p.m. and 6.00 a.m. shall be substituted for the foregoing hours.

(2) during a period of restriction in which stage 2 has been brought into operation:

- (a) to water any private garden or any commercial and industrial garden by means of fixed sprinklers except between 7.00 a.m. and 10.00 a.m.;
- (b) to water any municipal garden or any sports ground by means of fixed spinklers except between 7.00 a.m. and 10.00 a.m. provided however that where an automatically controlled watering system has been installed 12 midnight and 3.00 a.m. shall be substituted for the foregoing hours;
- (c) to water any nursery or market garden or to cool any commercial poultry building by means of fixed sprinklers except between 6.00 a.m. and 9.00 p.m.;
- (d) to fill any tanker unless such water is required for domestic use or stock and taken from a standpipe hydrant stopcock or other point of supply authorized by the Commission and only between 8.00 a.m. and 12 noon on any day provided however that—
 - (i) water for purposes other than for domestic use or stock may be taken between the foregoing hours subject to the prior written authority of the Commission to such filling being first obtained; and
 - (ii) where such water is required to flush any street gutter or drain for public health purposes filling may occur at any time;
- (e) to operate any fountain or water display.

(3) during a period of restriction in which stage 3 has been brought into operation:

- (a) to water any private garden or any commercial and industrial garden except by means of a hose watering can or other similar container held in the hand;
- (b) to water any municipal garden or sports ground by means of fixed sprinklers except between 8.00 a.m. and 9.00 a.m.;
- (c) to water any market garden or nursery by means of fixed sprinklers except between 5.00 a.m. and 8.00 p.m.;
- (d) to cool any commercial poultry building by means of a sprinkler system except between 6.00 a.m. and 9.00 p.m.;
- (e) to fill or to add to the contents of any dam tank or like container situate upon premises used for any agricultural or horticultural purpose unless the prior written authority of the Commission is first obtained;
- (f) to wash any vehicle other than by means of a bucket or other similar container filled direct from a tap and held in the hand unless—
 - (i) the washing of the vehicle is necessary for the purpose of public health and it has been established to the satisfaction of the Commission that such vehicle can only be properly cleansed by means of a hose; or
 - (ii) the washing of a vehicle is carried out for fee or reward by a vehicle cleaning establishment or business where—
 - (a) the washing is carried out mechanically and provision has been made for recirculation of the cleaning water, or

- (b) the washing is carried out manually and rinsing hoses are fitted with a trigger-operated nozzle which will shut off the flow of water when released;
- (g) to fill or to add to or replace the water in any swimming pool or wading pool except by means of a hose held in the hand or by means of a watering can or other similar container filled direct from a tap and held in the hand;
- (h) to wash any drive any path any walk any paved surface or any building except by means of a watering can or other similar container filled direct from a tap and held in the hand unless the washing is necessary in the interests of public health or is required for the construction or repair of any building or works;
- (i) to fill any tanker unless such water is required for domestic use or stock and taken from a standpipe hydrant stopcock or other point of supply authorized by the Commission and only between 8.00 a.m. and 12.00 noon on any day provided however that—
- (i) water for purposes other than for domestic use or stock may be taken between the foregoing hours subject to the prior written authority of the Commission to such filling being first obtained; and
- (ii) where such water is required to flush any street gutter or drain for public health purposes filling may occur at any time;
- (j) to operate any fountain or water display.
- (4) during a period of restriction in which stage 4 has been brought into operation:
- (a) to water any private garden except by means of a hose held in the hand between 7.00 p.m. and 9.00 p.m. or by means of a watering can or other similar container filled direct from a tap and held in the hand;
- (b) to water any commercial and industrial garden any municipal garden or sports ground except by means of a hose held in the hand between 8.00 a.m. and 10.00 a.m. or by means of a watering can or other similar container filled direct from a tap and held in the hand;
- Provided* however that porous tennis courts may not be watered except by means of a hose held in the hand for one half hour between 8.00 a.m. and 9.00 a.m. and one half hour between 4.00 p.m. and 5.00 p.m. on each day of the week and for a maximum of 5 minutes per hour between 9.00 a.m. and 6.00 p.m. on days of play;
- (c) to water any market garden or any nursery by means of fixed sprinklers except between 5.00 a.m. and 8.00 p.m.;
- (d) to cool any commercial poultry building by means of a sprinkler system except between 6.00 a.m. and 9.00 p.m.;
- (e) to fill or to add to the contents of any dam tank or like container situate upon premises used for any agricultural or horticultural purpose unless the prior written authority of the Commission is first obtained;
- (f) to wash any vehicle except by means of a bucket or other similar container unless—
- (i) the washing of the vehicle is necessary for the purpose of public health and it has been established to the satisfaction of the Commission that such vehicle can only be properly cleansed by the means of a hose; or
- (ii) the washing of vehicles is carried out for fee or reward by a vehicle cleaning establishment or business where—
- (a) the washing is carried out mechanically and provision has been made for recirculation of the cleaning water, or
- (b) the washing is carried out manually and rinsing hoses are fitted with a trigger-operated nozzle which will shut off the flow of water when released;
- (g) (i) to add to the water in any private swimming pool or wading pool except where such pool is provided with means of filtration and recirculation of the water and only by means of a hose held in the hand between 7.00 p.m. and 9.00 p.m. or by means of a watering can or other similar container filled direct from a tap and held in the hand;
- (ii) to fill or to replace the water in any private swimming pool or wading pool except where such pool is provided with means of filtration and recirculation of the water and only where the prior written authority of the Commission to such filling or replacement has been first obtained;
- (h) to wash any drive path walk paved surface or building except by means of a watering can or other similar container filled direct from a tap and held in the hand unless the washing is such as is necessary in the interests of public health or is required for the construction or repair of any building or works;
- (i) to fill any tanker unless such water is required for domestic use or stock and taken from a standpipe hydrant stopcock or other point of supply authorized by the Commission and only between 8.00 a.m. and 12.00 noon on any day provided however that—
- (i) water for purposes other than for domestic use or stock may be taken between the foregoing hours subject to the prior written authority of the Commission to such filling being first obtained; and
- (ii) where such water is required to flush any street gutter or drain for public health purposes filling may occur at any time;
- (j) to operate any fountain or water display.
- (5) during a period of restriction in which stage 5 has been brought into operation:
- (a) to water any lawn or grass area situate in any private garden or in any commercial and industrial garden or in any municipal garden;
- (b) to water garden beds trees and shrubs situate in any private garden except by means of a hose held in the hand between 7.00 p.m. and 9.00 p.m. or by means of a watering can or other similar container filled direct from a tap and held in the hand;
- (c) to water garden beds trees and shrubs situate in any commercial and industrial garden or municipal garden except by means of a hose held in the hand between 8.00 a.m. and 10.00 a.m. or by means of a watering can or other similar container filled direct from a tap and held in the hand;
- (d) to water any sports ground except by means of a watering can or other similar container filled direct from a tap except

that to the extent hereinafter prescribed water may be used by means of a hose or hoses held in the hand between the hours hereinafter stated—

- (i) Cricket Grounds—(wicket area only) between 8.00 a.m. and 10.00 a.m. each day of the week other than Tuesday and Saturday;
 - (ii) Golf Courses—(greens only) between 8.00 a.m. and 10.00 a.m. on each day of the week other Tuesday and Saturday;
 - (iii) Bowling trugo and croquet greens—only between 8.00 a.m. and 10.00 a.m. on each day of the week other than Tuesday and Saturday;
 - (iv) Tennis Courts—(play surface only) other than a court situate in a private garden or commercial and industrial garden—
 - (a) porous surface courts—one half hour between 8.00 a.m. and 9.00 a.m. and one half hour between 4.00 p.m. and 5.00 p.m. on each day of the week other than Monday and Wednesday and on days of play a maximum of 5 minutes per hour between 9.00 a.m. and 6.00 p.m. other than Monday and Wednesday;
 - (b) lawn surface courts—between 7.00 p.m. and 9.00 p.m. on each day of the week other than Friday and Sunday;
 - (v) Athletic Grounds—(running tracks and surfaces used for field games only) between 8.00 a.m. and 10.00 a.m. on each day of the week other than Tuesday and Saturday;
 - (vi) Racecourses—(running tracks only) between 7.00 p.m. and 9.00 p.m. on each day of the week other than Tuesday and Saturday;
- (e) to water any market garden or any nursery by means of fixed sprinklers except between 5.00 a.m. and 8.00 p.m.;
- (f) to cool any commercial poultry building by means of a sprinkler system except between 6.00 a.m. and 9.00 p.m.;
- (g) to fill or to add to the contents of any dam tank or like container situate upon premises used for agricultural or horticultural purposes unless the prior written consent of the Commission is first obtained;
- (h) to wash any vehicle except by means of a bucket or other similar container filled direct from a tap and held in the hand unless—
- (i) The washing of the vehicle is necessary for the purpose of public health and it has been established to the satisfaction of the Commission that such vehicle can only be properly cleansed by the means of a hose; or
 - (ii) the washing of vehicles is carried out for fee or reward by a vehicle cleaning establishment or business where—
 - (a) the washing is carried out mechanically and provision has been made for recirculation of the cleaning water; or
 - (b) the washing is carried out manually and rinsing hoses are fitted with a trigger-operated nozzle which will shut off the flow of water when released;
- (i) (i) to add to the water in any private swimming pool or wading pool except where such pool is provided with means of filtration and recirculation of the water and only by means of a hose held in the hand between 7.00 p.m. and 9.00 p.m. or by means of a watering can or other similar container filled direct from a tap and held in the hand;
- (ii) to fill or to replace the water in any private swimming pool or wading pool except where such pool is provided with means of filtration and recirculation of the water and only where the prior written consent of the Commission to such filling or replacement has been first obtained;
- (j) to wash any drive path walk paved surface or building except by means of a watering can or other similar container filled direct from a tap and held in the hand unless the washing is such as is necessary in the interests of public health or is required for the construction or repair of any building or works;
- (k) to fill any tanker unless such water is required for domestic use or stock and taken from a standpipe hydrant stopcock or other point of supply authorized by the Commission and only between 8.00 a.m. and 12.00 noon on any day provided however that—
- (i) water for purposes other than for domestic use or stock may be taken between the foregoing hours subject to the prior written authority of the Commission to such filling being first obtained; and
 - (ii) where such water is required to flush any street gutter or drain for public health purposes filling may occur at any time;
- (l) to operate any fountain or water display.
- (6) during a period of restriction in which stage 6 has been brought into operation:
- (a) to water any lawn or grass area situate in any private garden or any commercial and industrial garden or in any municipal garden;
 - (b) to water garden beds trees and shrubs and sporting facilities situate in a private garden except—
 - (i) by means of a hose held in the hand provided that only one hose is in use at any one time between 7.00 p.m. and 9.00 p.m. on every Monday Wednesday and Friday for properties having an even street number and every Tuesday Thursday and Saturday for properties having an odd street number or no street number;
 - (ii) by a watering can or other similar container filled direct from a tap and held in the hand between 8.00 a.m. and 10.00 a.m. on those days of the week on which the use of a hose is not permitted under subparagraph (i) of this paragraph;
 - (c) to water garden beds trees and shrubs situate in any commercial and industrial garden except by means of a hose held in the hand between 8.00 a.m. and 10.00 a.m. on every Monday Wednesday and Friday and by means of a watering can or other similar container filled direct from a tap between 8.00 a.m. and 10.00 a.m. on every Tuesday Thursday Saturday and Sunday;
 - (d) to water garden beds trees or shrubs situate in any municipal garden except by means of a hose held in the hand between 8.00 a.m. and 10.00 a.m. on each

- Monday Wednesday and Friday and by means of a watering can or other similar container filled direct from a tap and held in the hand at any time;
- (e) to water any sports ground except by means of a watering can or other similar container filled direct from a tap and held in the hand except that to the extent hereinafter prescribed water may be used by means of a hose or hoses held in the hand between the hours hereinafter stated—
- (i) Cricket Grounds—(wicket area only) between 8.00 a.m. and 10.00 a.m. on each day of the week other than Tuesday and Saturday;
 - (ii) Golf Courses—(greens only) between 8.00 a.m. and 10.00 a.m. on each day of the week other than Tuesday and Saturday;
 - (iii) Bowling trugo and croquet greens—only between 8.00 a.m. and 10.00 a.m. on each day of the week other than Saturday and Sunday;
 - (iv) Tennis Courts—(play surface only) other than those situate in a private garden or a commercial and industrial garden—
 - (a) porous surface courts—one half hour between 8.00 a.m. and 9.00 a.m. and one half hour between 4.00 p.m. and 5.00 p.m. each day of the week other than Monday and Wednesday and on a day of play a maximum of 5 minutes per hour between 9.00 a.m. and 6.00 p.m. on each day of the week other than Monday and Wednesday;
 - (b) lawn surface courts—between 7.00 p.m. and 9.00 p.m. on each day of the week other than Friday and Sunday;
 - (v) Athletics Grounds—(running tracks and surfaces used for field games only) between 8.00 a.m. and 10.00 a.m. each day of the week other than Tuesday and Saturday;
 - (vi) Racecourses—(running tracks only) between 7.00 p.m. and 9.00 p.m. on each day of the week other than Tuesday and Saturday;
- (f) to water any market garden or nursery by means of fixed sprinklers except between 5.00 a.m. and 8.00 p.m.;
- (g) to cool any commercial poultry building by means of a sprinkler system except between 6.00 a.m. and 9.00 p.m.;
- (h) to fill or to add to the contents of any dam tank or like container situate upon premises used for any agricultural or horticultural purpose unless the prior written authority of the Commission is first obtained;
- (i) to wash a vehicle except by means of a bucket or other similar container filled direct from a tap and held in the hand unless—
- (i) the washing of the vehicle is necessary for the purpose of public health and it has been established to the satisfaction of the Commission that such vehicle can only be properly cleansed by the means of a hose; or
 - (ii) the washing of vehicles is carried out for fee or reward by a vehicle cleaning establishment or business where—
 - (a) the washing is carried out mechanically and provision has been made for recirculation of the cleaning water; or
 - (b) the washing is carried out manually and rinsing hoses are fitted with a trigger-operated nozzle which will shut off the flow of water when released;
- (j) (i) to add to the water in any private swimming pool or wading pool except where such pool is provided with means of filtration and recirculation of the water and only by means of a bucket or other similar container filled direct from a tap between 7.00 p.m. and 9.00 p.m. on—
- (a) Monday Wednesday and Friday of each week for properties having an even street number;
 - (b) Tuesday Thursday and Saturday of each week for properties having an odd street number or no street number;
- (ii) to fill or to replace the water in any private swimming pool or wading pool except where such pool is provided with means of filtration and recirculation of the water and only where the prior written authority of the Commission to such filling or replacement has been first obtained;
- (k) to wash any drive path walk paved surface or building except by means of a watering can or other similar container held in the hand unless the washing is such as is necessary in the interests of public health or is required for the construction of any building or works;
- (l) to fill any tanker unless such water is required for domestic use or stock and taken from a standpipe hydrant stopcock or other point of supply authorized by the Commission and only between 8.00 a.m. and 10.00 a.m. Monday to Friday provided however that—
- (i) water for purposes other than for domestic use or stock may be taken between the foregoing hours subject to the prior written authority of the Commission to such filling being first obtained; and
 - (ii) where such water is required to flush any street gutter or drain for public health purposes filling may occur at any time;
- (m) to operate any fountain or water display.
- (7) during a period of restriction in which stage 7 has been brought into operation:
- (a) to water any lawn or grass area situate in any private garden or any commercial and industrial garden or any municipal garden;
 - (b) to water any garden bed trees or shrubs situate in a private garden except by means of a watering can or other similar container filled direct from a tap and held in the hand between 8.00 a.m. and 9.00 a.m. and between 7.00 p.m. and 8.00 p.m.;
 - (c) to water any garden beds trees or shrubs situate in a commercial and industrial garden except by means of a watering can or other similar container filled direct from a tap and held in the hand between 8.00 a.m. and 9.00 a.m. and between 4.00 p.m. and 5.00 p.m.;
 - (d) to water any garden beds trees or shrubs situate in a municipal garden except by means of a hose held in the hand between 8.00 a.m. and 10.00 on Tuesday and Friday of each week and by means of a watering can or other similar container filled direct from a tap and held in the hand between 8.00 a.m. and 10.00 a.m. on Monday Wednesday Thursday Saturday and Sunday;
 - (e) to water any sports ground except by means of a watering can or other similar container filled direct from a tap and held

in the hand except that to the extent hereinafter prescribed water may be used by means of a hose or hoses held in the hand between the hours hereinafter stated—

- (i) Cricket Grounds—(wicket area only) between 8.00 a.m. and 10.00 a.m. on each day of the week other than Tuesday and Saturday;
 - (ii) Golf Courses—(greens only) between 8.00 a.m. and 10.00 a.m. on each day of the week other than Tuesday and Saturday;
 - (iii) Bowling trugo and croquet greens—only between the hours of 8.00 a.m. and 10.00 a.m. on each day of the week other than Saturday and Sunday;
 - (iv) Tennis Courts (play surface only) other than those situate in a private garden or in a commercial and industrial garden—
 - (a) porous surface courts—one half hour between 8.00 a.m. and 9.00 a.m. and one half hour between 4.00 p.m. and 5.00 p.m. on each day of the week other than Monday and Wednesday and on a day of play a maximum of 5 minutes per hour between 9.00 a.m. and 6.00 p.m. other than Monday and Wednesday;
 - (b) lawn surface courts—between 7.00 p.m. and 9.00 p.m. on each day of the week other than Friday and Sunday;
 - (v) Athletic Grounds—(running tracks and surfaces used for field games only) between 8.00 a.m. and 10.00 a.m. on each day of the week other than Tuesday and Saturday;
 - (vi) Racecourses—(running tracks only) between 7.00 p.m. and 9.00 p.m. on each day of the week other than Tuesday and Saturday;
 - (f) to water any market garden or nursery by means of fixed sprinklers except between 5.00 a.m. and 8.00 p.m.;
 - (g) to cool any commercial poultry building by means of a sprinkler system except between 6.00 a.m. and 9.00 p.m.;
 - (h) to fill or to add to the contents of any dam tank or like container situate upon premises used for agricultural or horticultural purposes unless the prior written consent of the Commission is first obtained;
 - (i) to wash any vehicle except by means of a bucket or other similar container filled direct from a tap unless—
 - (i) the washing of the vehicle is necessary for the purpose of public health and it has been established to the satisfaction of the Commission that such vehicle can only be properly cleansed by means of a hose; or
 - (ii) the washing of vehicles is carried out for fee or reward by a vehicle cleaning establishment or business where—
 - (a) the washing is carried out mechanically and provision has been made for recirculation of the cleaning water; or
 - (b) the washing is carried out manually and rinsing hoses are fitted with a trigger-operated nozzle which will shut off the flow of water when released;
 - (j) (i) to add to the water in any private swimming pool or wading pool except where such pool is provided with means of filtration and recirculation of the water and only by means of a watering can or other similar container filled direct from a tap between 7.00 p.m. and 9.00 p.m. on—
 - (a) Monday Wednesday and Friday of each week for properties having an even street number;
 - (b) Tuesday Thursday and Saturday of each week for properties having an odd street number or no street number;
 - (ii) to fill or to replace the water in any private swimming pool or wading pool except where such pool is provided with means of filtration and recirculation of the water and only where the prior written authority of the Commission to such filling or replacement has been first obtained;
 - (k) to wash any drive path walk paved surface or building except by means of a watering can or other similar container filled direct from a tap and held in the hand unless the washing is such as is necessary in the interests of public health or is required for the construction or repair of any building or works;
 - (l) to fill any tanker unless such water is required for domestic use or stock and taken from a standpipe hydrant stopcock or other point of supply authorized by the Commission and only between 8.00 a.m. and 10.00 a.m. Monday to Friday provided however that—
 - (i) water for purposes other than for domestic use or stock may be taken between the foregoing hours subject to the prior written authority of the Commission to such filling being first obtained; and
 - (ii) where such water is required to flush any street gutter or drain for public health purposes filling may occur at any time;
 - (m) to operate any fountain or water display.
- (8) during a period of restriction in which stage 8 has been brought into operation:
- (a) to water any private garden or commercial and industrial garden or municipal garden or sports ground;
 - (b) to water any market garden or nursery by means of fixed sprinklers except between 5.00 a.m. and 10.00 a.m. or except between 6.00 p.m. and 10.00 p.m.;
 - (c) to cool any commercial poultry building by means of a sprinkler system except between 6.00 a.m. and 9.00 p.m.;
 - (d) to fill or to add to the contents of any dam tank or like container situate upon premises used for any agricultural or horticultural purposes unless the prior written authority of the Commission is first obtained;
 - (e) to wash a vehicle unless required by law;
 - (f) to fill add water to cleanse or replace the water in any private swimming pool or wading pool;
 - (g) to wash any drive path walk paved surface or building except by means of a watering can or other similar container filled direct from a tap and held in the hand unless the washing is such as is necessary in the interests of public health or is required for the construction or repair of any building or works;
 - (h) to fill tankers except where such water is required to flush any street gutter or drain for public health purposes;
 - (i) to operate any fountain or water display.
7. The occupier of any premises shall not cause permit or suffer any hose therein to be connected to any tap stopcock or pipe supplied with water by the Commission

other than during the approved times for the use of hoses as set out herein provided that an approved fire hose may be connected to approved firefighting facilities at all times.

8. The Commission having regard to the water supply then available may by declaration published in a newspaper—

- (a) Specify the hour and day of the conclusion of a period of restriction where such conclusion was not specified when the period of restriction was declared;
- (b) Specify an earlier conclusion where the hour and day of the conclusion of the period of restriction was specified when the period of restriction was declared.

9. Any person who uses or permits or suffers water supplied by the Commission to be used contrary to the provisions of this By-law shall be guilty of an offence and shall be liable to a penalty not exceeding One Hundred Dollars.

If any person supplied with water by the Commission wrongfully does or causes or permits to be done anything in contravention of this By-law the Commission may (without prejudice to any remedy in respect thereof) close or cut off any of the pipes or aqueducts by or through which water is supplied to him or for his use and may cease to supply him with water as provided by the Water Act 1958.

The foregoing By-law was made by the State Rivers and Water Supply Commission on 27 September 1982, and the common seal of the said Commission was hereto affixed, on 27 September 1982, in the presence of—

(SEAL) J. S. F. ROGERSON, Commissioner
D. J. CONSTABLE, Commissioner

Approved by the Governor in Council, 6 October 1982—
L. G. HOUSTON, Acting Clerk of the Executive Council

Police Offences Act 1958, No. 6337

DIVISION 1A—STATE CLASSIFICATION OF PUBLICATIONS BOARD

Take note that the State Classification of Publications Board has classified the following publications in accordance with the provisions of section 180H (1) of the Police Offences Act 1958.

Each publication shall be subject to the following restrictions:

- (a) it shall not be offered for sale sold or delivered to any person under the age of eighteen years;
- (b) It shall not be made available for inspection or perusal by any person under the age of eighteen years.

SCHEDULE OF PUBLICATIONS

Title	Distributor
Army Mistress	Venus Enterprises Pty. Ltd.
Big Blue Book, The	Gordon & Gotch Ltd.
Exotics—Vol. 1 No. 1	Gordon & Gotch Ltd.
Funny Half Hour—No. 128	Claredale Holdings Pty. Ltd.
Funny Half Hour—Nos. 159 and 160	Claredale Holdings Pty. Ltd.
Jays of Fantasy	Claredale Holdings Pty. Ltd.
P.M. Vol. 2 No. 8	Gordon & Gotch Ltd.
Teaser/Sudden Affair	Venus Enterprises Pty. Ltd.

R. V. DOOLEY, Acting Secretary
State Classification of Publications Board

Police Offences Act 1958, No. 6337

DIVISION 1A—STATE CLASSIFICATION OF PUBLICATIONS BOARD

Take note that the State Classification of Publications Board has classified the following publications in accordance with the provisions of section 180H (1) of the Police Offences Act 1958.

Each publication shall be subject to the following restrictions:

- (a) it shall not be offered for sale sold or delivered to any person under the age of eighteen years;
- (b) It shall not be made available for inspection or perusal by any person under the age of eighteen years;
- (c) it shall not be exhibited or displayed in any place to which persons under the age of eighteen years have access or so that it is visible from any such place.

SCHEDULE OF PUBLICATIONS

Title	Distributor
Crew—No. 2	Venus Enterprises Pty. Ltd.
Drag Queens—Vol. 3 No. 4	Venus Enterprises Pty. Ltd.
4orty Plus—Vol. 1 No. 4	Venus Enterprises Pty. Ltd.
Playbirds Continental—No. 17	Melbourne Wholesale Newsagency Pty. Ltd.
Rubber & Latex Special—Part "D"	Venus Enterprises Pty. Ltd.
Rubber Quarterly—No. 1	Venus Enterprises Pty. Ltd.
Rubber Quarterly—No. 2	Venus Enterprises Pty. Ltd.
Smooth—Nos. 14—30 inc.	Hallmark Book Wholesalers
Teen Boobs & Beavers No. 1	Claredale Holdings Pty. Ltd.

R. V. DOOLEY, Acting Secretary
State Classification of Publications Board

Police Offences Act 1958, No. 6337

DIVISION 1A—STATE CLASSIFICATION OF PUBLICATIONS BOARD

Take note that the State Classification of Publications Board has classified the following publications in accordance with the provisions of section 180H (1) of the Police Offences Act 1958.

Each publication shall be subject to the following restrictions:

- (a) it shall not be offered for sale sold or delivered to any person under the age of eighteen years;
- (b) It shall not be made available for inspection or perusal by any person under the age of eighteen years;
- (c) it shall not be exhibited or displayed in any place to which persons under the age of eighteen years have access or so that it is visible from any such place;
- (d) it shall not be advertised in any manner whatsoever.

SCHEDULE OF PUBLICATIONS

Title	Distributor
Blondes Have More Cum—No. 2	Venus Enterprises Pty. Ltd.
Chick Licks—No. 9	Claredale Holdings Pty. Ltd.
Daddy's Girl	Claredale Holdings Pty. Ltd.
Dildo Babes—Vol. 2 No. 1	Venus Enterprises Pty. Ltd.
Erotic Desire—Nos. 3 and 4	Venus Enterprises Pty. Ltd.
Erotic Desire—Nos. 7 and 8	Venus Enterprises Pty. Ltd.
Erotic Desire—Nos. 10 and 11	Venus Enterprises Pty. Ltd.
Exciting—No. 20	Claredale Holdings Pty. Ltd.
Fantasy Fuck—No. 1	Claredale Holdings Pty. Ltd.
John Holmes And The All Star Porno Queens—Vol. 1 No. 1	Venus Enterprises Pty. Ltd.
Kock Knockers—No. 1	Claredale Holdings Pty. Ltd.
Lesbian Love—No. 11	Claredale Holdings Pty. Ltd.
Lesbian Lovers—Vol. 2 No. 2	Venus Enterprises Pty. Ltd.
Limited Edition—Film Review—Nos. 10 and 11	Claredale Holdings Pty. Ltd.
Popsuckle—No. 1	Venus Enterprises Pty. Ltd.
T.V. Treats—Vol. 3 No. 3	Venus Enterprises Pty. Ltd.

R. V. DOOLEY, Acting Secretary
State Classification of Publications Board

Police Regulation Act 1958
VICTORIA POLICE FORCE

DETERMINATION NO. 379 OF THE POLICE SERVICE BOARD

The Police Service Board, in pursuance of the powers in that behalf conferred by the *Police Regulation Act 1958*, hereby makes the following Determination (that is to say):

1. The Determination No. 179 of the Police Service Board of 14 December 1971, and published in the *Government Gazette* of 25 January 1972, as amended, is hereby further amended as follows:

1.1 In paragraph 42 (6) (a) by deleting the amount "\$13 000" and substituting therefor the following new amount "\$25 000".

1.2 In paragraph 62 (A) (ii) (b) by deleting the amount "\$13 000" and substituting therefor the following new amount "\$25 000".

2. This Determination shall come into operation on and from 1 October 1982.

Dated 28 September 1982

T. B. SHILLITO
A Judge of the County Court of Victoria,
Chairman and Member of the Police Service
Board

G. DAVIDSON
Member of the Police Service Board

F. J. LESLIE
Member of the Police Service Board

Police Regulation Act 1958
VICTORIA POLICE FORCE

DETERMINATION NO. 378 OF THE POLICE SERVICE BOARD

The Police Service Board, in pursuance of the powers in that behalf conferred by the *Police Regulation Act 1958*, hereby makes the following Determination (that is to say):

1. The Determination No. 179 of the Police Service Board of 14 December 1971, and published in the *Government Gazette* of 25 January 1972, as amended, is hereby further amended as follows:

1.1 By deleting the whole of paragraph 15 and substituting therefor the following new paragraph:

"RESEARCH AND DEVELOPMENT DEPARTMENT

There shall be paid to a member while holding the rank and position specified in the first column hereunder, an allowance at the rate set forth in the second column hereunder—

FIRST COLUMN	SECOND COLUMN
<i>Rank or Position</i>	<i>Daily Allowance</i>
	\$
Chief Superintendent—Deputy to the Assistant Commissioner	2.88
Other Officers	2.72
Sub-Officers	2.55"

2. This Determination shall come into operation on and from 3 October 1982.

Dated 28 September 1982

T. B. SHILLITO
A Judge of the County Court of Victoria,
Chairman and Member of the Police Service
Board

G. DAVIDSON
Member of the Police Service Board

F. J. LESLIE
Member of the Police Service Board

Police Regulation Act 1958

VICTORIA POLICE FORCE

DETERMINATION No. 380 OF THE POLICE SERVICE BOARD

The Police Service Board, in pursuance of the powers in that behalf conferred by the *Police Regulation Act 1958*, hereby makes the following Determination (that is to say):

1. The Determination No. 179 of the Police Service Board of 14 December 1971, and published in the *Government Gazette* of 25 January 1972, as amended, is hereby further amended as follows:

1.1 In paragraph 7—

By deleting the preamble thereto and sub-paragraphs (a), (b) and (c) thereof and substituting therefor the new preamble and sub-paragraphs (a), (b) and (c) as follows:

“7. Save for other Commuted Penalty Rates prescribed elsewhere in this Determination 179 the salaries and Commuted Penalty Loadings and Rates to be paid to members designated in this paragraph shall be in accordance with the following scales:

SCALES OF ANNUAL SALARIES AND COMMUTED PENALTY LOADINGS AND RATES

(a) Officers

Rank (1)	Base salary (2)	Commuted penalty loading (overtime and recall) (3)	Commuted penalty loading (weekends, public holidays, shift work and stand-by) (4)	Total salary (5)
	\$	\$	\$	\$
Commander	38 691	4 140	2 205	45 036
Chief Superintendent	35 320	3 779	2 013	41 112
Superintendent	33 005	3 532	1 881	38 418
Chief Inspector	29 922	3 202	1 706	34 830
Inspector	29 118	3 116	1 660	33 894
(b) Sub-Officers				
Senior Sergeant	24 652	..	3 205	..
Sergeant	22 034	..	2 864	..

(c) Senior Constables and Constables

Rank (1)	Base salary (2)	Commuted penalty rates (weekends, public holidays and shift work) (3)
	\$	\$
Senior Constables—		
During 12th year of service and after	19 898	2 587
During 7th to 11th years of service	19 521	2 538
During 5th and 6th years of service	19 308	2 510
During 3rd and 4th years of service	19 086	2 481
During 1st and 2nd years of service	18 864	2 452
Constables—		
During 7th year of service and after	18 002	2 340
During 5th and 6th years of service	17 808	2 315
During 3rd and 4th years of service	17 441	2 267
Probationary Constables—		
During 2nd year of service	16 522	2 148
During 1st year of service	15 211	1 977

1.2 In paragraph 8—

By deleting the whole of paragraph 8.

1.3 In paragraphs 9-15, inclusive—

By deleting, wherever occurring, the rates shown in Table "A" and substituting therefor, wherever occurring, the corresponding new rates shown in Table "B".

" TABLE 'A' (Present Rates)	TABLE 'B' (Corresponding New Rates)
\$	\$
.37	.39
.46	.48
.72	.76
.79	.83
.88	.92
.90	.94
.94	.99
.97	1.02
1.01	1.06
1.07	1.12
1.10	1.15
1.16	1.22
1.20	1.26
1.25	1.31
1.33	1.40
1.40	1.47
1.48	1.55
1.50	1.57
1.57	1.65
1.66	1.74
1.67	1.75
1.73	1.81
1.80	1.89
1.87	1.96
1.94	2.04
1.97	2.07
1.98	2.08
2.04	2.14
2.05	2.15
2.12	2.22
2.14	2.24
2.19	2.30
2.27	2.38
2.35	2.47
2.40	2.52
2.43	2.55
2.46	2.58
2.51	2.63
2.57	2.70
2.59	2.72
2.66	2.79
2.75	2.88
2.88	3.02
3.00	3.15
3.05	3.20
3.11	3.26
3.36	3.52
3.46	3.63
3.63	3.81
3.69	3.87
3.86	4.05
3.93	4.12
4.58	4.80
4.64	4.87
5.40	5.66
5.76	6.04
6.32	6.63
6.46	6.78
6.90	7.24
8.06	8.45."

- 1.4 In paragraph 27—
By deleting the proviso to sub-paragraph 27 (b).
- 1.5 In paragraph 28AA—
By deleting the proviso and substituting therefor the following proviso:
“Provided that the proportion of the aforesaid Commuted Penalty Loading at 5.7 per centum attributable to duty performed by him on Week-ends, Public Holidays and on Shiftwork shall, in total, be taken as being 5.16 per centum of his base salary, and that attributable to duty performed on standby shall be taken as being 0.52 per centum of that salary.”
- 1.6 In paragraph 33 (1) by deleting the amounts “\$3170” and “\$2653” and substituting therefor the following new amounts “\$3325” and “\$2783”.
- 1.7 In paragraph 34 (1) by deleting the amount “\$1474” and substituting therefor the following new amount “\$1546”.
- 1.8 In paragraph 34A by deleting the proviso thereto.
- 1.9 In the Third Schedule by deleting from (b) the expression “For details of daily allowances see appendix” and substituting therefor the following new expression:
“The daily rates of allowances for personal expenses of members travelling abroad are those detailed in the Public Service Board Determination at Appendix A (Part 1, Rate 1) pursuant to Public Service Board Determination 152.”
- 1.10 By deleting the whole of Part I from the Third Schedule.

2. In this Determination 380 the amendments made in the sub-paragraphs hereof shown in Column (1) to the references to and paragraphs of Determination 179 shown in Column (2) shall come into operation on and from the dates shown, respectively, in Column (3) as follows:

<i>Determination 380</i>	<i>Determination 179</i>	<i>Date of Operation</i>
(1)	(2)	(3)
Sub-paragraph—	Paragraph—	
1.1	7 (Preamble and (a)-(c))	22 August 1982
1.2	8	22 August 1982
1.3	9-15	22 August 1982
1.4	27 (b)	22 August 1982
1.5	28AA	22 August 1982
1.6	33 (1)	22 August 1982
1.7	34 (1)	22 August 1982
1.8	34A	22 August 1982
1.9	Third Schedule (b)	17 May 1982
1.10	Third Schedule (Part I)	17 May 1982

Dated 28 September 1982

T. B. SHILLITO
A Judge of the County Court of Victoria,
Chairman and Member of the Police Service
Board

G. DAVIDSON
Member of the Police Service Board

F. J. LESLIE
Member of the Police Service Board

Police Regulation Act, Section 122
SALE OF UNCLAIMED MOTOR VEHICLE
 An owner is required for an unregistered red, partially stripped mini bike (make not known).
 The vehicle came into possession of Police on 22 November 1981, and if not claimed, will be sold by public auction at the Nunawading Police Station, corner Whitehorse Road and Humphreys Avenue, Nunawading, at 10.00 a.m. on Thursday, 28 October 1982.

J. R. HALL
 Acting Chief Commissioner

Police Regulation Act, Section 122
SALE OF UNCLAIMED MOTOR VEHICLE
 An owner is required for an unregistered red 50 cc Kawasaki mini bike, Engine No. NTE-24273.
 The vehicle came into possession of Police on 5 December 1981, and if not claimed, will be sold by public auction at the Nunawading Police Station, corner Whitehorse Road and Humphreys Avenue, Nunawading, at 10.00 a.m. on Thursday, 28 October 1982.

J. R. HALL
 Acting Chief Commissioner

Police Regulation Act, Section 122
SALE OF UNCLAIMED MOTOR VEHICLE
 An owner is required for a 1964 model fawn and white EH Holden station wagon, previous Registration No. JSD 656, Engine No. Y24152.
 The vehicle came into possession of Police on 26 February 1981, and if not claimed, will be sold by public auction at the Caulfield Police Station, 289-291 Hawthorn Road, Caulfield, at 10.00 a.m. on Wednesday, 3 November 1982.

J. R. HALL
 Acting Chief Commissioner

Police Regulation Act, Section 122
SALE OF UNCLAIMED MOTOR VEHICLE
 An owner is required for an unregistered motor cycle, make unknown, approximately 80 cc engine capacity, black/red frame No. 0/21/0034, yellow front mudguard, white rear mudguard.
 The vehicle came into possession of Police on 23 May 1982, and if not claimed, will be sold by public auction at the Caulfield Police Station, 289-91 Hawthorn Road, Caulfield at 10 a.m. on Monday, 25 October 1982.

R. J. HALL
 Acting Chief Commissioner of Police

SHIRE OF RIPON
ROAD DEVIATION ORDER
 Pursuant to the provisions of sections 522 and 526 of the *Local Government Act 1958* the Council of the Shire of Ripon hereby directs that the land in the Parish of Brewster indicated by hatching on the plan hereunder, which has been purchased taken or acquired by it, shall be a public highway on and from the date of publication of this Order in the *Government Gazette* and declares that such land shall be a public highway in lieu of the land indicated by cross hatching on the said plan.

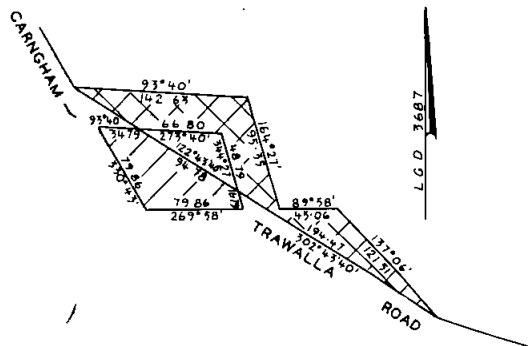

The common seal of the President, Councillors and Ratepayers of the Shire of Ripon was hereunto affixed, 19 July 1982—

(SEAL) C. J. HEDGES, President
 F. J. O'BRIEN, Councillor
 F. W. GLARE, Secretary

Confirmed by the Governor in Council, 28 September 1982—TOM FORRISTAL, Clerk of the Executive Council

Local Government Act 1958
NOTICE OF CONFIRMATION OF AN ORDER OF THE COUNCIL OF THE SHIRE OF COBRAM ADOPTING A PROPOSAL FOR THE CLOSURE OF RIVER ROAD AND KAROOK STREET, COBRAM, TO THROUGH TRAFFIC

Pursuant to the provisions of section 539c of the *Local Government Act 1958*, the Governor in Council, on 28 September 1982 confirmed an order of the Council of the Shire of Cobram made on 19 April 1982 adopting a proposal for the closure of River Road and Karook Street, Cobram, to through traffic by the erection of barriers as shown on the plan hereunder.

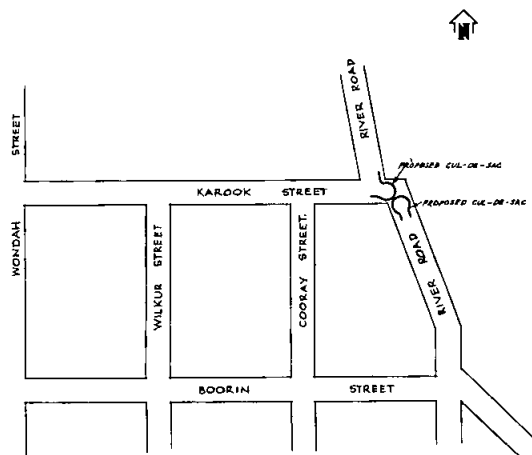

TOM FORRISTAL
 Clerk of the Executive Council

Local Government Department
 Melbourne (82/2139)

SHIRE OF TUNGAMAH WATERWORKS TRUST
FIXING THE LIMIT OF BANK OVERDRAFT
 His Excellency the Governor of the State of Victoria by and with the advice of the Executive Council thereof has by Order made on 28 September 1982, fixed the total amount of the sums which the Shire of Tungamah Waterworks Trust may owe at any one time in respect of moneys borrowed by overdraft of current account pursuant to the provisions of section 288 of the *Water Act 1958*, at Twenty thousand dollars (\$20 000).

TOM FORRISTAL
 Clerk of the Executive Council

At the Executive Council Chamber
 Melbourne, 28 September 1982

METROPOLITAN FIRE BRIGADES BOARD
PERMISSION TO HOLD FIRE BRIGADE DEMONSTRATIONS
 In pursuance of the provisions of section 62 of the *Metropolitan Fire Brigades Act 1958*, the Metropolitan Fire Brigades Board has granted permission for the holding of fire brigade demonstrations as under:

Organisation; Date; Venue

Ford Motor Company of Australia Ltd.; 19 and 26 October 1982; Broadmeadows Plant.

A. F. ROWDEN
 Secretary

Private Agents Act 1966

NOTICE OF RECEIPT OF APPLICATIONS FOR LICENCES UNDER THE PROVISIONS OF THE PRIVATE AGENTS ACT 1966

The Clerk(s) of the Magistrates' Court(s) as listed hereunder hereby give notice that applications, as under, have been lodged for hearing by the said Court(s) on the date(s) specified.

Any person desiring to object to any of such applications must—

- (a) lodge with the respective Clerk of the Magistrates' Court a notice in the prescribed form of his objection and of the grounds thereof;
- (b) cause a copy of such notice to be served personally or by post upon the applicant at least three days before the hearing of the application; and
- (c) send or deliver—
 - (i) where the objection is not made by the officer in charge of the police district in which the Court is situated—a copy of the notice to such officer; and
 - (ii) where the objection is not made by the Registrar or Deputy Registrar—a copy to the Registrar.

<i>Full Name of Applicant*</i>	<i>Place of Abode of Applicant or Nominee</i>	<i>Name of Firm or Corporation</i>	<i>Address for Registration</i>	<i>Type of Licence</i>	<i>Date of Hearing</i>
MAGISTRATES' COURT, CAMBERWELL					
Eyres, Carl Rudolph	35 Asquith St, Kew		35 Asquith St, Kew	Process Server	29.10.82
Dated at Camberwell 29 September 1982 P. M. PATTISON, Clerk of the Magistrates' Court					
MAGISTRATES' COURT, CRANBOURNE					
Dickman, Allan Frederick	76 Circle Dr North, Cranbourne		76 Circle Dr North, Cranbourne	Inquiry Agent	27.10.82
Dated at Cranbourne 29 September 1982 G. CHIRGWIN, Clerk of the Magistrates' Court					
MAGISTRATES' COURT, FRANKSTON					
Hill, Darren Lawrence	4/134 Williams St, Frankston		4/134 Williams St, Frankston	Guard Agent	22.10.82
Dated at Frankston 30 September 1982 B. O'TOOLE, Clerk of the Magistrates' Court					
MAGISTRATES' COURT, SUNSHINE					
Dawson, Ian	57 Benjamin St, Sunshine	Metropolitan Security Service	McDonald Rd, Brooklyn	Watchman	8.11.82
Dated at Sunshine 29 September 1982 J. ISAACS, Clerk of the Magistrates' Court					
MAGISTRATES' COURT, HAMILTON					
Trotter, Allan Geoffrey	39 Stephen St, Hamilton	Keap Security	35 Winter St, Coleraine	Watchman	21.10.82
Beard, Paul Edward	1 Jackson St, Casterton	" "	" "	" "	" "
Dated at Hamilton 27 September 1982 K. E. CROTTY, Clerk of the Magistrates' Court					
MAGISTRATES' COURT, PORT MELBOURNE					
Donaldson, Trevor William	24 Gladstone St, Windsor	Security Express	390 St Kilda Rd, Melbourne	Watchman	21.10.82
Dated at Port Melbourne 24 September 1982 S. BRYANT, Clerk of the Magistrates' Court					
MAGISTRATES' COURT, SPRINGVALE					
Johnson, Mark	12 Bonita Crt, North Dandenong		23 Buckley St, Noble Park	Inquiry Agent	22.10.82
" "	" "		" "	Process Server	"
Dated at Springvale 28 September 1982 R. LYNEHAM, Clerk of the Magistrates' Court					

* Or in the case of a firm or corporation, of the Nominee

PRIVATE AGENTS—continued

Full Name of Applicant*	Place of Abode of Applicant or Nominee	Name of Firm or Corporation	Address for Registration	Type of Licence	Date of Hearing
MAGISTRATES' COURT, MELBOURNE					
Bennett, William Brian	119 Suffolk Rd, North Sunshine	Armaguard	699 Queensberry St, North Melbourne	Watchman	11.11.82
Blackney, Douglas John	21 Gilmour Crt, Greensborough	"	" "	"	"
Hearn, Rodney Allan	14/4 Davidson St, South Yarra	"	" "	"	"
McKenzie, William John	Fryers Rd, Chewton	"	" "	"	"
Grieve, Brian Ernest	2/134 Lower Dandenong Rd, Mordialloc	T.N.T. Group 4	54 Racecourse Rd, North Melbourne	"	"
Chapman, Peter Gerard	9/601 Upper Heidelberg Rd, Heidelberg	" "	" "	"	"
Kerslake, Daryl John	7 Folkstone Cres, Ferntree Gully	" "	" "	"	"
Anderson, George Arthur	81 Mulhall Dr, St Albans	" "	" "	"	"
Dated at Melbourne 28 September 1982 M. QUIRK, Clerk of the Magistrates' Court					
MAGISTRATES' COURT, HEIDELBERG					
Miles, Steven Roderick	203 The Boulevard, East Ivanhoe		5 Poole St, Box Hill	Guard Agent	28.10.82
Verillo, Felice	28 Blamey Av, Mill Park		28 Blamey Av, Mill Park	Inquiry Agent	"
Dated at Heidelberg 28 September 1982 E. HACKETT, Clerk of the Magistrates' Court					
MAGISTRATES' COURT, FOOTSCRAY					
Suttie, Donald David	79 Devonshire Rd, Sunshine		79 Devonshire Rd, Sunshine	Watchman	12.10.82
Dated at Footscray 22 September 1982 D. GEER, Clerk of the Magistrates' Court					
MAGISTRATES' COURT, COBURG					
Carlson, Royston	23 Amaroo Way, Yallambie	Armaguard (Coburg)	Bakers Rd, North Coburg	Watchman	25.10.82
Dated at Coburg 27 September 1982 P. WENDEN, Clerk of the Magistrates' Court					
MAGISTRATES' COURT, PRAHRAN					
Musgrave, Leo John	444 Buckley St, West Essendon	Mayne Nickless Limited	390 St Kilda Rd, Melbourne	Watchman	22.10.82
Dowsey, Robert Donald	42 Agora Bvd, Ferntree Gully	" "	" "	"	"
Davis, Brett Antony	4/28 Breakwater Rd, East Geelong	" "	" "	"	"
Lewis, James Barry	12 Woonah St, Chadstone	" "	" "	"	"
Dated at Prahran 28 September 1982 J. ARDLEY, Clerk of the Magistrates' Court					
MAGISTRATES' COURT, SOUTH MELBOURNE					
Burrage, Andrew Geoffrey	52 Bindy St, Forrest Hill	Security Protection Pty. Ltd.	165 Moray St, South Melbourne	Watchman	9.11.82
Legg, David	16 Fresno St, Altona	Dennis Murphy	1 Crane St, South Melbourne	"	"
Dated at South Melbourne 28 September 1982 R. McHUGH, Clerk of the Magistrates' Court					
MAGISTRATES' COURT, MILDURA					
McGlashan, Grant Anthony	1 Heath St, Red Cliffs		111 Magnolia Ave, Mildura	Watchman	18.10.82
Dated at Mildura 20 September 1982 G. SCHMIDT, Clerk of the Magistrates' Court					

* Or in the case of a firm or corporation, of the Nominee

PRIVATE AGENTS—continued

Full Name of Applicant*	Place of Abode of Applicant or Nominee	Name of Firm or Corporation	Address for Registration	Type of Licence	Date of Hearing
MAGISTRATES' COURT, SUNSHINE					
Culverston, John Leslie	45 Tarlee Dr, St Albans	Ian Eddy	146 Ashley St, Maidstone	Watchman	1.11.82
Dated at Sunshine 21 September 1982 J. ISAACS, Clerk of the Magistrates' Court					
MAGISTRATES' COURT, CASTLEMAINE					
Oliver, Leslie Douglas	6 Carol St, Castlemaine		Coolstore Rd, Harcourt	Watchman	21.10.82
Dated at Castlemaine 22 September 1982 G. K. SMART, Clerk of the Magistrates' Court					
MAGISTRATES' COURT, TRARALGON					
Spithoven, Michelle Frances	4/18 Charles St, Traralgon		1st Floor, Suite 7, Roland Hill Building, 82 Hotham St, Traralgon	Process Server	18.10.82
Dated at Traralgon 22 September 1982 K. G. McMAHON, Clerk of the Magistrates' Court					
MAGISTRATES' COURT, FRANKSTON					
Hornibrook, Janet Ida	144 Nepean Hwy, Seaford	J. I. Hornibrook	144 Nepean Hwy, Seaford	Process Server	15.10.82
Dated at Frankston 24 September 1982 B. O'TOOLE, Clerk of the Magistrates' Court					
MAGISTRATES' COURT, GEELONG					
Johnson, Colin William	28 Bruthen Rd, Highton		28 Bruthen Rd, Highton	Inquiry Agent	11.10.82
" " "	" "		" "	Process Server	"
Dated at Geelong 20 September 1982 J. E. REILLY, Clerk of the Magistrates' Court					
MAGISTRATES' COURT, FERNTREE GULLY					
Williams, Michelle Christine	15 Stanley St, The Basin	Michelle Christine Williams	15 Stanley St, The Basin	Process Server	20.10.82
Dated at Ferntree Gully 27 September 1982 B. DOBSON, Clerk of the Magistrates' Court					
MAGISTRATES' COURT, FRANKSTON					
White, Neville Barry	1 Lutana Crt, Frankston	Neville Barry White and Assistants	733 Boronia Rd, Wantirna	Inquiry Agent	—.—.82
Dated at Frankston 20 September 1982 B. O'TOOLE, Clerk of the Magistrates' Court					
MAGISTRATES' COURT, ELTHAM					
Ruzic, Martin	Plenty Rd, Bundoora	Schutzeneck Security Service	121 Thompson Cres, Research	Watchman	20.10.82
Dated at Eltham 24 September 1982 G. BALE, Clerk of the Magistrates' Court					
MAGISTRATES' COURT, ELTHAM					
Paul, Linda Yvonne	12 Anne St, Diamond Creek		12 Anne St, Diamond Creek	Process Server	20.10.82
Dated at Eltham 28 September 1982 G. BALE, Clerk of the Magistrates' Court					
MAGISTRATES' COURT, WODONGA					
Harrison, Peter Ronald	RMB 350A, Howlong Rd, Albury		93 York St, South Melbourne	Watchman	26.10.82
Dated at Wodonga 23 September 1982 P. DODGSON, Clerk of the Magistrates' Court					

* Or in the case of a firm or corporation, of the Nominee

PRIVATE AGENTS—continued

Full Name of Applicant*	Place of Abode of Applicant or Nominee	Name of Firm or Corporation	Address for Registration	Type of Licence	Date of Hearing
MAGISTRATES' COURT, BOX HILL					
Visser, William Hank	228 Manchester Rd, Mooroolbark		75 Husband Rd, Forest Hill	Watchman	1.11.82
Dated at Box Hill 21 September 1982 W. E. BYRNE, Clerk of the Magistrates' Court					
MAGISTRATES' COURT, SOUTH MELBOURNE					
Bullen, Wayne Gregory	7 Apollo Rd, Taylors Lakes	Dennis Murphy	1 Craine St, South Melbourne	Watchman	9.11.82
Pownall, Graeme Leslie	7 Snowgum Crt, Werribee	" "	" "	"	"
Robinson, Bradley Simon	13 Mitchell St, Bentleigh	" "	" "	"	"
Dated at South Melbourne 27 September 1982 R. McHUGH, Clerk of the Magistrates' Court					
MAGISTRATES' COURT, FITZROY					
Svrzlic, Pavo	25 Oxford St, West Footscray	Roden Security Services	136 Johnston St, Fitzroy	Watchman	25.10.82
Dated at Fitzroy 27 September 1982 G. SHARKEY, Clerk of the Magistrates' Court					
MAGISTRATES' COURT, SPRINGVALE					
Shorter, David Barry	54 Cleeland St, Dandenong		11 Wardale Rd, Springvale South	Inquiry Agent	5.11.82
" " "	" "		" "	Process Server	"
" " "	" "		" "	Commercial Sub-Agent	"
" " "	" "		" "	Watchman	"
Dated at Springvale 27 September 1982 R. LYNEHAM, Clerk of the Magistrates' Court					
MAGISTRATES' COURT, CHELSEA					
Pryor, Theodore Cedric	3 Sunnyside Ave, Nunawading		1st Floor, 434 Nepean Hwy, Chelsea	Process Server (Individual)	1.11.82
Dated at Chelsea 27 September 1982 H. McINNES, Clerk of the Magistrates' Court					
MAGISTRATES' COURT, SPRINGVALE					
Morgan, Kevin Frederick	Calder Hwy, Macedon	Neil A. Wood	11 Wardale Rd, Springvale South	Commercial Sub-Agent	15.10.82
Dated at Springvale 24 September 1982 R. LYNEHAM, Clerk of the Magistrates' Court					

* Or in the case of a firm or corporation, of the Nominee

AUCTION SALES ACT 1958

BALLARAT—Notice is hereby given that the Annual Meeting of Justices for the Licensing of Auctioneers will be held at the Magistrates' Court, Ballarat, on Tuesday, 23 November 1982 at 10 o'clock in the forenoon. Dated at Ballarat, 28 September 1982—D. L. CROFT, Clerk of the Magistrates' Court, Ballarat.

CASTLEMAINE—Notice is hereby given that the Annual Meeting of Justices for the Licensing of Auctioneers will be held at the Magistrates' Court, Castlemaine, on Tuesday, 23 November 1982, at 10 o'clock in the forenoon. Dated at Castlemaine, 22 September 1982—G. K. SMART, Clerk of the Magistrates' Court, Castlemaine.

GEE LONG—Notice is hereby given that the Annual Meeting of Justices for the Licensing of Auctioneers will be held at the Law Courts, Geelong on Tuesday, 23 November 1982, at 10 o'clock in the forenoon. Dated at Geelong, 24 September 1982—J. E. REILLY, Clerk of the Magistrates' Court, Geelong.

No. 101—55580/82—2

EXEMPTION REQUEST No. 3 of 1982

On 29 September 1982 the Equal Opportunity Board considered an application from the City of Hawthorn for the grant of an exemption under section 34 of the *Equal Opportunity Act 1977* to enable some balance of the sexes to exist among pool attendants at the Hawthorn Community Recreation Centre.

Bearing in mind the duties involved in the position and in particular the need for pool attendants to supervise changing rooms, the Board hereby grants an exemption from the provisions of section 18 (1) (a) and (c) of the *Equal Opportunity Act* in relation to the advertising for and the offering of employment to pool attendants at the Hawthorn Centre, in order to maintain some balance of the sexes.

This exemption shall remain in effect until 29 September 1982.

JOAN DWYER, Chairman
IAN SHARP, Member
BREEN CREIGHTON, Alternate Member

EXEMPTION REQUEST No. 4 OF 1982

On 29 September 1982 the Equal Opportunity Board considered an application under section 34 (2) of the Equal Opportunity Act by Orana, the Peace Memorial Homes for Children for a further extension of the exemption granted by the Board on 11 September 1979 to enable a balance of the sexes to be maintained amongst Child Care Workers and Assistants employed by Orana. The Board grants the application and hereby extends the period of exemption from the provisions of section 18 (1) (a) and section 18 (1) (c) and section 53 of the *Equal Opportunity Act 1977* to 29 September 1985.

JOAN DWYER, Chairman
IAN SHARP, Member
BREEN CREIGHTON, Alternate Member

Transport Regulation Act
TRANSPORT REGULATION BOARD
HEARING OF APPLICATIONS

Notice is hereby given that the following applications will be considered by the Transport Regulation Board on 26 October 1982.

BREWSTER, J. H., DYASON, J. B. & STONEY, G., Mansfield. Application to license one oversnow tracked vehicle, with seating for six persons to be purchased, to operate for the carriage of supplies, equipment and passengers within areas inaccessible to conventional vehicles in the Mansfield area in conjunction with the applicants' snow skiing and bush walking excursions.

BREWSTER, J. H., DYASON, J. B. & STONEY, G., Mansfield. Application to license two 4-wheel drive vehicles each with seating capacity for approximately twelve persons, to be purchased, to operate for the carriage of supplies, equipment and passengers in conjunction with the applicants' snow skiing and bush walking excursions as follows:

(A) WINTER SEASON

(i) Weekend Excursion

Friday—Passengers upon arrival in Mansfield on the Melbourne-Mansfield bus service will be transferred by 4-wheel drive vehicles to overnight accommodation at Stockyard Creek near Sheeppark Flat on the Howqua Track.

Saturday—Following breakfast party will travel to The Bluff via 8-mile gap on the Howqua Track. At the practical limit of 4-wheel drive travel, passengers will alight the vehicle and ski to The Bluff Hut. Packs, supplies, equipment and those passengers unable to make the journey by ski will be transferred to The Bluff Hut by an oversnow tracked vehicle. Upon arrival at the Hut and subject to prevailing weather conditions, short excursions to either Mt. Lovick or The Bluff will be undertaken. Returning to the Hut for overnight accommodation.

Sunday—Party will depart the Hut by skis on a guided tour of surrounding area until approximately 2.00 p.m. at which time party will depart for Mansfield to connect with bus service to Melbourne.

Fares—\$195.00 per person.

(ii) 4-Day Excursion

Day 1—Monday—Depart Mansfield at 9.00 a.m. by 4-wheel drive vehicle to The Bluff, stopping at Stockyard Creek for morning tea and to issue and check equipment and to discuss the coming days activities. Following a light lunch passengers will be transferred to The Bluff Hut as in Weekend Excursion above.

Day 2—Tuesday—Party will ski The Bluff and Mt. Eadley Stoney returning to The Bluff Hut for overnight accommodation.

Day 3—Wednesday—Party will ski Mt. Lovick and surrounds then on to King Billy to camp at Guys Yard overnight. Equipment and supplies will be transferred to Guys Yard by oversnow tracked vehicle.

Day 4—Thursday—Party will travel to Mt. Clear and depart via Brocks Road, returning to Mansfield by 4-wheel drive vehicle arriving at approximately 6.00 p.m.

Fares—\$295.00 per person.

(iii) 7-Day Excursion

Days 1, 2 and 3—As per first three days of 4-Day Excursion above.

Day 4—Party will ski from Guys Yard to Macalister Springs for overnight accommodation, via Mt. Magdala and Mt. Howitt, carrying tents, sleeping bags and supplies.

Day 5—Party will ski Mt. Howitt and cross cut saw area returning to Macalister Springs for overnight accommodation.

Day 6—Party will ski from Macalister Springs to Guys Yard for overnight accommodation.

Day 7—Party will ski from Guys Yard to Mt. Clear then depart via Brocks Road by 4-wheel drive vehicle to Mansfield.

Fares—\$420 per person. Accommodation, meals, transport from Mansfield and equipment included.

(B) OTHER SEASONS—On bush walking and 4-wheel drive excursions on both day and overnight basis to places in the Mansfield Forest district and Macalister Springs, including Mt. Cobbler, Mt. Speculation, The Bluff, Mt. Lovick, Mt. Magdala, Howitt Plains, Mt. Stirling, Mirimbah and Merrijig.

Fares—To be determined.

CROYDON BUS SERVICE PTY. LTD., Croydon. Application to license one commercial passenger vehicle with seating capacity for a minimum of eighteen persons, to operate a trial bus service between Scoresby, Rowville, Ferntree Gully and Upper Ferntree Gully as follows:

Route—Commencing at the corner of Stud and Ferntree Gully Roads, Scoresby via Stud Road, Kelletts Road, Napoleon Road, Glenfern Road, Trafalgar Street, Roberts Street, Parkview Drive, Glenfern Road, Yarrowee Street, Acacia Road, Willow Road, Mount View Road, Dawson Street, Townley Street, Albert Street, Talaskia Road and Burwood Highway to Upper Ferntree Gully Railway Station, then via Burwood Highway, Talaskia Road, Albert Street, Townley Street, Dawson Street, Burwood Highway, Willow Road, Acacia Road, Yarrowee Street, Glenfern Road, Trafalgar Street, Roberts Street, Parkview Drive, Glenfern Road, Lysterfield Road, Selman Avenue and Station Street to Ferntree Gully Railway Station. Then via Station Street, Burwood Highway, Ferntree Gully Road, Mountain Gate Drive, Windermere Drive, Dairy Lane and Ferntree Gully Road to the intersection of Ferntree Gully and Stud Roads, Scoresby.

TIME-TABLE

Monday-Friday

Span: 8.00 a.m.—5 p.m.
Frequency: 60 minutes

Buses will depart Scoresby alternatively via Stud Road or Ferntree Gully Road. *Sections and Fares*—To be determined. Service is designed to connect with the applicants existing route services 693 and 665 at Scoresby and with Route 693 and rail at Ferntree Gully and Upper Ferntree Gully.

ELLIS, P. H., Dingley. Application for two special purpose vehicle licences in respect of 1957 Jaguar sedans, each with a seating capacity for five persons, to operate from 182-184 Spring Road, Dingley for the carriage of passengers for wedding parties only. This application replaces a previous application which appeared in *Victoria Government Gazette* No. 96 of 29 September 1982.

JOHN M. CULLEEN PTY. LTD., Wangaratta. Application to license one commercial passenger vehicle with seating capacity for 45 persons, to operate as a Country Special Service Omnibus from within a 20-km pickup radius of the Wangaratta Post Office. The vehicle to be licensed will hold a 4-star rating for charter purposes.

KING, A. A., Kew. Application to license one commercial passenger vehicle, with seating capacity for eighteen persons, to be purchased, to operate as a Touring Omnibus on the following tours: 1. *Yarra Valley Vineyards Day Tour*—Pick-up passengers at various Melbourne Hotels between 8.30 a.m. and 9.00 a.m.

and depart Melbourne via Hoddle Street, Eastern Freeway, Doncaster Road, Maroondah Highway, Warburton Highway to Wesburn to the Settlement Vineyard and Restaurant for morning tea and wine tasting, returning along the Warburton Highway and Maroondah Highway to East Seville, then via Gruyere Road for 10 km to the Warramate Vineyard for a discussion with the winemakers on winemaking techniques and management followed by a tour and tasting, then on to the Yarra Yerring Vineyard for tour and tasting and lecture from the winemaker, then via Maddens Lane, Maroondah Highway, to St. Huberts Winery for tour and tasting, then via Maroondah Highway to Lilydale to the Olinda Park Restaurant, arriving at 1.00 p.m. for lunch departing restaurant at 2.30 p.m. via Maroondah Highway, Yarra Glen Road and Yea Road to the Chateau Yarringa Winery, for tour and tasting, then on to Fergusons Winery for tour and tasting, returning to Melbourne Hotels at 5.30 p.m.

Fares—Adults \$65.00. Children \$55.00.

2. *Goulburn Valley Winery Day Tour*—Pick-up passengers at various Melbourne Hotels between 8.30 a.m. and 9.00 a.m. depart Melbourne via Royal Parade, Sydney Road and Hume Highway to Seymour to the Seymour Vineyards for tasting, then via Hume Highway, Goulburn Valley Highway to the Chateau Tabilk Winery, 8 km south-west of Nagambie for tour of the cellars and wine tasting, then on to the Mitchelton Winery for tour, tasting and lunch at 12.30 p.m., then on to Graytown to the Osicka Winery, 25 km south of Nagambie for tasting, returning to Melbourne Hotels at 5.30 p.m.

Fares—Adults \$65.00. Children \$55.00.

3. *Overnight Tour of Bendigo and Avoca Wineries*—Pick-up passengers at various Melbourne Hotels between 8.30 a.m. and 9.00 a.m. and depart Melbourne via Flemington Road, Tullamarine Freeway and Sunbury Road to Lancefield, then to Knights Granite Hills Vineyard, Baynton, for inspection and tasting, then to Kyneton, then via Calder Highway to Chateau Le Amon Winery to meet the winemaker and tasting, then on to Castlemaine for lunch at 12.30 p.m., then on to Harcourt to the Harcourt Valley Vineyard for tour and tasting, then to the Township of Maldon for tour of town, dinner and overnight stay. Depart Maldon at 11.00 a.m. via Pyrenees Highway to Moonabel to either the Taltarni or Warrenmang Vineyards for tour and tasting, then on to the Summerfield Vineyard for tasting and lunch at 12 noon, return to Avoca to the Mt. Avoca Vineyard for tour and tasting, then on to the Chateau Remy Vineyard for tour and tasting and afternoon tea returning to Melbourne via Sunraysia and Western Highways at 5.00 p.m.

Fares—To be determined.

McGOWAN, V. J. & A. J. BROUGHTON, Northcote. Application to license one commercial passenger vehicle with seating capacity for approximately eleven persons, to operate as a Touring Omnibus on the following tours: (i) *Western Victoria Historical Tour*—Day 1—Depart Melbourne for Ballarat to visit local points of interest and overnight motel accommodation. Day 2—Depart Ballarat for "Carranballac" homestead via Skipton for inspection and lunch. Then on to Port Fairy via Darlington, Noorat, Terang and Warrnambool. Overnight motel accommodation at Port Fairy. Day 3—Depart motel accommodation to visit local points of interest at Port Fairy and Tower Hill returning to Port Fairy for overnight motel accommodation. Day 4—Depart Port Fairy for inspection of Flagstaff Hill Maritime museum at Warrnambool, then on to Halls Gap via Hawkesdale, Peshurst and Dunkeld, to overnight motel accommodation. Day 5—Depart Halls Gap to inspect Mt. Zero Aboriginal Art Caves via Lah-arum, then on to Bunjil's Cave via Stawell via the Western Highway returning to Halls Gap via Pomonal for overnight motel accommodation. Day 6—Depart Halls Gap for inspection of Sepelts Winery at Great Western and on to Ararat to visit local points of interest. Then return to Melbourne via Ballarat.

(ii) *Wildlife and Wildflower Tour of Western Victoria*—Day 1—Depart Melbourne for Port Campbell, via Stoneyford and Cobden. Cliff top walk and overnight motel accommodation at Port Campbell. Day 2—Depart Port Campbell for the Twelve Apostles and Loch Ard Gorge, then on to Tower Hill via Warrnambool, stopping at London Bridge, Bay of Islands and Port Fairy. Overnight motel accommodation at Port Fairy. Day 3—Depart Port Fairy for Cape Nelson State Park via Portland and Swan Lake Flat in Discovery Bay Coastal Park then on to Nelson for overnight motel accommodation. Day 4—Depart motel accommodation for walks around Nelson and afternoon cruise up the Glenelg River to caves returning to overnight motel accommodation at Nelson. Day 5—Depart Nelson for Mount Gambier and Naracoorte to visit local points of interest. Overnight motel accommodation at Naracoorte. Day 6—Depart Naracoorte for Bool Lagoon then on to Nhill via Edenhope and Harrow-Nhill Road stopping at Springy-bark Nature Walk. Overnight motel accommodation at Nhill. Day 7—Depart Nhill for the Little Desert National Park for various walks, returning to Nhill for overnight motel accommodation. Day 8—Depart Nhill for the Wyperfeld National Park via Jeparit and Rainbow for afternoon walk and tour then on to overnight motel accommodation at Hopetoun. Day 9—Depart Hopetoun for Halls Gap via Warracknabeal, Rupanyup, Stawell and McKenzie Falls. Overnight motel accommodation at Halls Gap. Day 10—Depart motel accommodation for the Sundial Turntable for various walks then on to Bunjil's Cave via Stawell. Return to Halls Gap via Pomonal for overnight motel accommodation. Day 11—Depart Halls Gap for Dunkeld then return to Melbourne via Ballarat.

(iii) *West Coast of Victoria Tour*—Day 1—Depart Melbourne for Anglesea. Afternoon walk and overnight motel accommodation at Anglesea. Day 2—Depart motel accommodation for Wildflower walk and study then on to Lorne and Erskine Falls. Overnight motel accommodation at Lorne. Day 3—Depart Lorne for Apollo Bay to inspect Paradise treeferns, then on to Port Campbell via Laver's Hill stopping at the Twelve Apostles and Loch Ard Gorge. Overnight motel accommodation at Port Campbell. Day 4—Depart Port Campbell for Warrnambool stopping at London Bridge and Bay of Islands then on to Port Fairy for inspection of Flagstaff Hill. Overnight motel accommodation at Port Fairy. Day 5—Depart motel accommodation for tour of Port Fairy and Tower Hill returning to overnight motel accommodation at Port Fairy. Day 6—Depart Port Fairy for Portland for tour and inspection of museum then on to Nelson stopping at Swan Lake Flat in Discovery Bay Coastal Park then on to overnight motel accommodation at Nelson. Day 7—Depart motel accommodation for walks around Nelson and a cruise up the Glenelg River to caves then return to overnight motel accommodation at Nelson. Day 8—Depart Nelson for Melbourne via Dartmoor, Digby, Hamilton and Ballarat.

Fares—

Tour (i) \$450.00
Tour (ii) \$796.00
Tour (iii) \$596.00

NOTE—Cost includes travel, accommodation (shared twin rooms) two meals per day (morning and evening) and admission fees. Tours are designed specifically for Japanese tourists visiting Victoria and will be promoted in Japan using brochures. In addition the hiring party will be accompanied by a guide and an interpreter of Japanese.

Application for renewal of licences as shown by the persons listed hereunder to operate under the same terms and conditions.

HARRISON, F. C. & G. G., Echuca; T.O.80.
LOUTAS, S., West Preston; S.V.102.

Notice of any objections should be forwarded to reach the Secretary of the Board not later than 20 October 1982.

Interested parties are advised that it will not be necessary to appear on the hearing date specified, unless advised in writing by the Board.

C. J. V. SMITH
Secretary

Corner Lygon and Princes Streets, Carlton, 3053, Wednesday, 6 October 1982

STATE TENDER BOARD—CONTRACTS ACCEPTED

AMENDMENTS			
Schedule Number	Item Number	New Rate	Effective Date
		\$	
<i>Electrical Goods (Series 1981-83)</i>			
1/05	61	Olex List 28.9.82 less 35 per cent.	30.9.82
	63	Olex List Price: Rigid Conduit 6.9.82 less 30 per cent. Rigid Fittings 15.5.81 and 12.7.82 less 27½ per cent. Flexible Conduit 10.2.82 less 35 per cent. Rigid Ducts 9.6.80 less 26 per cent.	27.9.82
<i>Glass (Series 1981-83)</i>			
1/07	10	10.15*	1.10.82
	11	14.04*	
	12	19.21*	
	13	21.66*	
	14	21.66*	
	15	14.04*	
*Trading terms unchanged.			
<i>Paints and Painters' Sundries (Series 1981-83)</i>			
1/13	109	0.5984	25.9.82
	110	0.4824*	
*Delete: Drum deposit \$15.00, credited on return Add: \$30.00 refundable drum deposit			
<i>Construction Materials, Lime, etc. (Series 1982-84)</i>			
1/27	1	0.2655*	27.9.82
*Trading terms unchanged			
<i>Motor Spirit (Bulk)—State Petrol Centre (Series 1982)</i>			
1/53A	1	0.3523	25.9.82
	2	0.3627	
<i>Motor Spirit, Fuel Oils, Lubricants, etc. (Series 1982-83)</i>			
1/53B	3	0.3603	25.9.82
	7	0.3707	
	11	0.3673	
	12	0.3823*	
	13	0.3673	
	14	0.3823*	
	15	0.3777	
	16	0.3927*	
	17	0.3777	
	18	0.3927*	
	19	0.3860(m)	
		0.4010(s/s)	
	20	0.3860(m)	
		0.4010*(s/s)	
	21	0.5053	
	22	0.3953†	
	23	0.4616	
	24	0.3516†	
	26	413.28†	
	27	437.98†	
	28	0.3348†	
	33	247.79†	
	34	0.3364	
	41	0.8738(m)	30.9.82
		1.0238(c)	
	42	0.8868(m)	
	42	1.0368(c)	
	43	1.0378(m)	
		1.1878(c)	
	44	0.8109(m)	
		0.9609(c)	
	45	0.7429(m)	
	45	0.7429(m)	
		0.8929(c)	

*The Shell Company of Australia Limited

†Trading terms unchanged

(M) (per kg) metropolitan

(C) (per kg) country

AMENDMENTS—continued

Schedule Number	Item Number	New Rate	Effective Date
\$			
<i>Provisions—Melbourne and Metropolitan District (Series 1982-83)</i>			
2/01	61	25.53	4.10.82
	62	23.93	
	63	20.52	
<i>Provisions—Hobson Park—Traralgon (Series 1982-83)</i>			
2/24 (4)	5	11.43	24.9.82
	9	10.86	
	12	3.30	
	13	27.48	
	17	4.55	
	23	1.13	
	37	3.34	
	48	8.18	
	53	9.18	
	63	4.21	
<i>Cartage and Delivery of Goods and Parcels—Metropolitan (Series 1982-83)</i>			
4/05			
Change of Address:			
Delete: Downard-Pickfords Pty. Ltd., Lot 2, Bunney Rd., Clayton, 3168. Telephone: 552 1234.			
Add: Downard-Pickfords Pty. Ltd., 373-392 Lower Dandenong Rd, Braeside, 3195. Telephone: 586 7222.			

J. M. PAWSON, Secretary to the Tender Board

THE CAULFIELD RACECOURSE RESERVE
AMENDMENT TO REGULATIONS

We,

RUPERT WILLIAM JOHN CLARKE,
MAXWELL RONALD BLAIR,
JAMES DAVID MACDONALD,
WILLIAM RONALD WALTERS,
IAN GUY MILLER,
VANCE OAKLEY DICKIE,
FREDERICK JAMES GRANTER,
WALTER WILLIAM COCKRAM,
THOMAS RICHARD TREVASKIS,
GEOFFREY SIMON PATIENCE, and
WILLIAM JOHN FARQUHAR McDONALD,

being duly appointed Trustees of the land reserved for Racing, Recreation and Public Park purposes and premises, being Allotment A, at Caulfield, in the Parish of Prahran, County of Bourke, in the exercise of the powers conferred on us by the *Crown Land (Reserves) Act 1978* and of any and every power enabling us so to do, and with the approval of the Governor in Council, do hereby amend the Regulations made by the Trustees on 7 July 1931, and approved by the Governor in Council on 13 October 1931, and as were last amended by the Trustees on 3 March 1980, and approved by the Governor in Council on 18 March 1980, by amending the tolls, entrance fees and charges for admission stated in Regulation No. XVII to read:

For the admission of each person to the first and sixth divisions	\$ 7.00
For the admission of each person to the fourth and ninth divisions	3.00
For the admission to the eighth division of every motor car	2.00
or	
The annual equivalent of \$2 per race meeting.	
R. W. J. CLARKE	
M. R. BLAIR	
J. D. MacDONALD	
W. R. WALTERS	
I. G. MILLER	
VANCE DICKIE	
F. J. GRANTER	
W. W. COCKRAM	
T. R. TREVASKIS	
G. S. PATIENCE	
W. J. F. McDONALD	

Approved by the Governor in Council, 28 September 1982—TOM FORRISTAL, Clerk of the Executive Council

Melbourne and Metropolitan

BOARD OF WORKS

GENERAL NOTICE

The Melbourne and Metropolitan Board of Works having made provision for carrying off the sewage of each and every property which or any part of which is situate in the Sewerage Areas hereinafter described doth hereby declare that on and after 11 October 1982 each and every property so situate shall be deemed to be a sewered property within the meaning of the *Melbourne and Metropolitan Board of Works Act 1958*.

The Sewerage Areas hereinbefore referred to are:

Sewerage Area No. 4438

Shire of Sherbrooke—This area comprises lots 1 to 5 and that piece of land described on Plan of Consolidation No. 100612 Hughes Street.

Sewerage Area No. 4460

City of Springvale—This area comprises all lots in Westbury Court, Rainsford Court and Sarose Court, lots 24 and 25 Ferndale Court, lots 43 to 45 and 125 Sheridan Court, lots 91 to 97 Donhaven Court, lots 26 to 42, 52 to 58, 67 to 70 and 86 to 90 Village Drive, lots 2, 1, a further lot 1, a further lot 1, a further lot 1 and a further lot 1, lots 2 to 5 and 1 Howard Road.

Sewerage Area No. 4461

City of Waverley—This area comprises lot 1 Grantley Drive, lots 1, 42, 22, 23, 2 and 1 Thompson Street, lots 25, 26, 1 to 3, 29 to 33, 9 to 1, 34, 2, 1, 37 to 41, 1, 2 and 1 York Street, lots 24 to 22 Singer Avenue, lots 21 and 20 Capital Avenue, lots 10 to 13, 53 to 44 and 2 Campbell Street.

Sewerage Area No. 4473

Shire of Sherbrooke—This area comprises lots 226 to 231, 45 to 40, 79, 1 to 6, 1, 2, 84, 1, 2 and 86 Hume Street.

Sewerage Area No. 4474

Shire of Sherbrooke—This area comprises all lots in Melaleuca Drive and Photinia Court, lots 65 to 59 and 58 to 53 Morris Road, lots 1 to 10, 1, that piece of land described on Plan of Consolidation No. 108125, lots 4, 11 to 23 and 2 Glenfern Road, lots 24 and 86 to 89 Eloera Street, a Reserve abutting Morris Road and Eloera Street.

Sewerage Area No. 4491

Shire of Werribee—This area comprises all lots in Olive-tree Close and Aurora Court, lots 472 to 478 and 486 to 489 Shaws Road, lots 490 to 492, 508, 509, 524 and 525 Parklands Grove, a Reserve abutting Shaws Road and Olivetree Close.

Sewerage Area No. 4494

City of Moorabbin—This area comprises all lots in Newlands Court, Jacobs Drive and Imre Court, lots 1 to 8 Bourke Road, lots 9 to 13, 29 to 33 and 50 Sundowner Avenue, lots 51 to 57, 45 to 53, 30 to 34, 42 to 44 and 58 to 64 Davanzo Avenue.

Sewerage Area No. 4500

City of Waverley—This area comprises lots 16 to 14, 7, 6 and 11 to 8 Cuthbert Road, lots 3 to 1 and 5 to 1 Lum Road.

Sewerage Area No. 4504

City of Berwick—This area comprises lots 12 to 25, 11, 26, 2, 28, 1, 2, 30 to 41, 2, 1 and 4 to 1 Gardiner Street, lots 5, 6 and 2 Harkaway Road.

Sewerage Area No. 4507

Shire of Eltham—This area comprises all lots in Howgate Court, Sion Close and Treloar Avenue, lots 102 to 104, 156 to 154 and 86 to 88 Malabar Crescent, lots 75, 76, 81, 82, 146, 145 and 1 to 8 Glenister Drive, lots 144, 9, 10 and 16 to 14 Pitt Street.

Sewerage Area No. 4511

City of Knox—This area comprises all lots in Rosalie Court lots 119 to 110 Timothy Drive, lots 109, 108, 107 to 102, 101 to 89 and 65 to 62 Renou Road, lots 69 to 66, 88 to 79, 78 to 70 and a Municipal Reserve Flamingo Drive, a Municipal Reserve abutting Timothy Drive and Renou Road.

Sewerage Area No. 4513

City of Mordialloc—This area comprises that piece of land described on Registered Plan No. 16510, lots 71 and 72 Percy Street, that piece of land described on Plan of Consolidation No. 105600 Crown Avenue, lot 74 Avlona Street.

Sewerage Area No. 4516

City of Oakleigh—This area comprises lots 12 to 28, a Reserve, lots 29 to 41, 46 to 56 and 145 to 139 Murchison Crescent, lots 166 to 155, 44, 45, 42, 43 and 104 to 113 Spring Valley Drive.

Sewerage Area No. 4517

City of Knox—This area comprises all lots in Airlie Court, Balmoral Court, Lansell Court, Tattlar Place and Bristow Close, lots 77 to 79, 96 to 99, 1, 187 to 185, 166 to 162 and 146 to 144 Wentworth Avenue, lots 147 to 150, 151, 152, 160 and 161 Shady Grove.

Sewerage Area No. 4518

City of Keilor—This area comprises lot 784 Chichester Drive, lots 785 to 790 and 791 to 798 Cocoparra Crescent, lots 836 to 840 Hattah Court, lots 841 to 844 Belair Court.

Sewerage Area No. 4521

City of Altona—This area comprises lots 1 to 3, a Church Reserve and lots 1 to 6 Alma Avenue, lots 7 to 27, 1, 2, 31 and 32 Shirley Street, lots 39 to 63 and 4 to 26 Rosebery Street, lots 33 to 55 Hook Street.

Sewerage Area No. 4522

Shire of Lillydale—This area comprises all lots in Hansford Close, Hamilton Close, Donald Close and David Close, lots 104, 105, Gladesville Primary School, lots 68 to 85 and 53 to 46 Gladesville Drive, lots 43 to 45 Mount Dandenong Road, lots 54, 55, 40, 50 to 58, a Reserve, 59 to 62, 87 to 84, 83, 103 to 98, 1 to 3, 93 to 88, 1 to 4, 13 to 17, 28 to 32, 56 and 57 Cheryllne Crescent, lots 82 to 79 Landy Court.

Sewerage Area No. 4527

City of Waverley—This area comprises all lots in Wyuna Court, lots 823 to 836, 851 to 853, 854 to 862, 870 to 878, portion of a Municipal Reserve and lots 879 to 882 Grandview Road, lots 883 to 889, 890 to 892 and 893 to 902 Craig Hill Drive, lots 869, 868, 867, 866, 864 and 863 Bellara Way, a Municipal Reserve abutting Craig Hill Drive and Bellara Way.

Sewerage Area No. 4531

City of Keilor—This area comprises all lots in Altyre Court, lots 262 to 259, 244 and 215 to 221 Atheldene Drive, lots 222 to 228, 229 and 230 Tintern Grove, lots 231 to 239, a Reserve, 240, 241, 208 to 201, 187 and 186 Highcombe Crescent, lots 214 to 209, 242, 243, that piece of land described on Plan of Consolidation No. 108181 and lots 251 to 245 Kerrison Avenue, lots 263 to 267 Leyton Court, lot 252 Acuba Close, that piece of land described on Plan of Consolidation No. 108182 and lot 428 Damte Place.

5 October 1982

By order of the Board

O. T. W. COSGRIFF
Secretary

625 Little Collins Street, Melbourne, Vic. 3000

Stamps Act 1958

NOTICE UNDER SECTION 40A

Pursuant to section 40A of the Stamps Act 1958, I hereby declare B.P. Australia Limited to be an "authorized person" in relation to Bills of Exchange payable on demand drawn out of Victoria and received for the credit of the said company.

R. A. JOLLY
Treasurer

The Treasury
Melbourne, 14 September 1982

Approved by the Governor in Council, 6 October 1982—
L. G. HOUSTON, Acting Clerk of the Executive Council

This notice appears in lieu of the notice appearing on page 3226 of *Government Gazette* No. 98 of 29 September 1982.

Stamps Act 1958

NOTICE UNDER SECTION 40A

Pursuant to section 40A of the *Stamps Act 1958*, I hereby declare Susan Kirk, Lynette Long and Beverley Hill, Trading as—The Handling House—to be an "authorized person" in relation to Bills of Exchange payable on demand drawn out of Victoria and received for the credit of the said firm.

R. A. JOLLY
Treasurer

The Treasury
Melbourne, 14 September 1982

Approved by the Governor in Council, 6 October 1982—
L. G. HOUSTON, Acting Clerk of the Executive Council

This notice appears in lieu of the notice appearing on page 3226 of *Government Gazette* No. 98 of 29 September 1982.

Cities, towns and boroughs are not included in the investigation. A map of the area investigated is depicted hereunder.

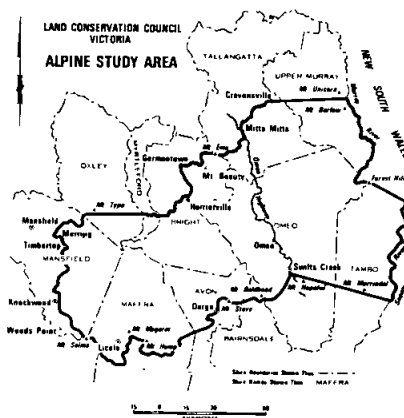

Land Conservation Act 1970

VICTORIAN GOVERNMENT

PUBLICATION OF REPORT—SPECIAL INVESTIGATION
ALPINE AREA

Pursuant to section 9 (3) I hereby give notice that on Monday, 11 October 1982 the Land Conservation Council will publish an abridged reprint of the descriptive resources report on the Alpine area, first released in 1977, and a smaller supplementary report which updates some of the information contained in the original report.

The abridged version of the report contains the original text and maps but does not include the photographs. The supplementary report adds to the original report as it contains up-to-date information on the tenure and use of land in the area and sets out to assess the values of public land outside the existing system of parks. The two reports read in conjunction are intended to assist people in preparing submissions on the best use of public land in the Alpine area.

The publications will be available for inspection at the offices of the Land Conservation Council, 464 St. Kilda Road, Melbourne from Monday, 11 October 1982.

Copies may be purchased from the Government Printer Sales Office, 41 St. Andrews Place, East Melbourne or from the Community Services Centre Bookshop, 1st Floor, 356 Collins Street, Melbourne from Monday, 11 October 1982. Mail orders accompanied by remittance, should be addressed to the Government Printer, P.O. Box 203, North Melbourne, 3051. The cost of the report and supplement is \$8.00 if collected or \$10.50 if posted. The supplement to the report may be purchased separately and is priced at \$1.00 if collected or \$2.50 if posted.

The Publications will not be available for purchase from the offices of the Council.

Submissions Invited on the Use of Public Land

Submissions are now invited from interested persons and bodies in regard to the future use of public land within the area. These submissions will be considered by the Council when making recommendations as to the balanced use of land.

Written submissions should be addressed to the Secretary, Land Conservation Council, 464 St. Kilda Road, Melbourne, 3004, and must be lodged on or before Friday, 10 December 1982.

The area includes portions of the Shires of Mansfield, Oxley, Myrtleford, Bright, Tallangatta, Upper Murray, Omeo, Maffra, Avon, Bairnsdale and Tambo.

I. KUNARATNAM, Secretary

Cemeteries Act 1958

SCALE OF FEES OF THE TUNGAMAH PUBLIC
CEMETERY

In pursuance of the powers conferred upon them by the Cemeteries Act, the trustees of the Tungamah Public Cemetery hereby make the following scale of fees, which shall come into operation upon publication in the *Government Gazette*, and from and after such publication every scale of fees heretofore made by the said trustees shall be and is hereby rescinded to the extent to which it conflicts with this scale.

Public Graves		\$
Interment in grave without exclusive right—		
stillborn child		25.00
Interment in grave without exclusive right—		
others		45.00
Number peg or label		10.00
Private Graves		
Land, 2.44 m x 1.22 m		70.00
Own selection of land (extra)		50.00
Miscellaneous Charges		
Interment fee		30.00
Interment outside prescribed hours, or on		
Saturdays, Sundays or Public Holidays or		
without due notice		40.00
Certificate of right of burial		5.00
Number plate or brick		10.00
Permission to erect a headstone or monument—		
5 per cent of cost with a minimum of \$10.00		
Exhuming the remains of a body (when auth-		
orized)		200.00
Interment of ashes in a private grave		30.00

W. BUERCKNER, Trustee
C. R. CAMPBELL, Trustee
F. W. MARKS, Trustee

Approved by the Governor in Council, 28 September 1982—TOM FORRISTAL, Clerk of the Executive Council

Cemeteries Act 1958

SCALE OF FEES OF THE ST. ARNAUD PUBLIC CEMETERY

In pursuance of the powers conferred upon them by the Cemeteries Act, the trustees of the St. Arnaud Public Cemetery hereby make the following scale of fees, which shall come into operation upon publication in the *Government Gazette*, and from and after such publication every scale of fees heretofore made by the said trustees shall be and is hereby rescinded to the extent to which it conflicts with this scale.

	\$
Memorial wall niche and plaque	100.00
Memorial wall niche—reservation	20.00
	L. P. ESMORE, Trustee
	R. A. LOVEL, Trustee
	F. McGRATH, Trustee

Approved by the Governor in Council, 28 September 1982—TOM FORRISTAL, Clerk of the Executive Council

Cemeteries Act 1958

SCALE OF FEES OF THE BEECHWORTH PUBLIC CEMETERY

In pursuance of the powers conferred upon them by the Cemeteries Act, the trustees of the Beechworth Public Cemetery hereby make the following scale of fees, which shall come into operation upon publication in the *Government Gazette*, and from and after such publication every scale of fees heretofore made by the said trustee shall be and is hereby rescinded to the extent to which it conflicts with this scale.

Private Graves

	\$
1. Land 2.44 m x 1.22 m	175*

Sinking Charges for Private Graves

2. Sinking grave 1.83 m deep	175*
3. Each additional 0.3 m	15.00
4. (a) Sinking oversize grave (extra)	30.00
(b) Sinking oversize grave for American type casket (extra)	30.00
5. Cancellation of order to sink (if commenced)	30.00

Reopening Charges

6. Reopening grave (no cover)	170.00
7. Reopening grave (with cover or kerb)	175.00

Public Graves

Interment in grave without exclusive rights—	
8. Stillborn child	115.00
9. Others	50.00

Extra Charges

10. Interment outside prescribed hours or on weekends or public holidays—Actual cost of overtime	
11. Annual maintenance (single grave)—optional	25.00
12. Monumental fees—	
(a) New monument	80.00
(b) Additional inscription	30.00
(c) Renovation of monument	60.00
13. Permission to construct a brick grave or to erect any stone kerb, brick, tilework or concrete	80.00
14. Exhumations (when authorized)	175.00
15. Interment of ashes in a private grave	90.00
16. Interment of ashes in the ground (not in existing grave)	90.00
17. Interment of ashes in memorial wall	90.00

* For children up to two years old, 50 per cent of ground and sinking fees to be charged.

K. McINTOSH, Trustee
J. P. STOCKDALE, Trustee
B. G. FORREST, Trustee

Approved by the Governor in Council, 28 September 1982—TOM FORRISTAL, Clerk of the Executive Council

PUBLIC TRUSTEE ACT 1958, SECTION 17

I hereby give notice that on 21 September 1982 the Public Trustee filed Elections to Administer the following deceased persons' estates in accordance with section 17 of the *Public Trustee Act 1958*.

BARTHOLOMEW, BERYL AGNES, late of 4 Adamson Street, Heidelberg, married woman, died 16 April 1982.

FRASER, ANGUS, late of Room 5/55 Linda Crescent, Hawthorn, pensioner, died 5 August 1982.

HARFORD, GRACE, formerly known as Grace Findlater, late of Flat 75/332 Park Street, South Melbourne, pensioner, died 13 July 1982.

HOURLIGAN, JOHN JOSEPH, formerly of 26 Hutchinson Street, East Brunswick, late of St. Josephs Home, St. Georges Road, Northcote, retired driver, died 30 June 1982.

MALAMIN, MICHAEL, late of 51 Grey Street, St. Kilda, pensioner, died 28 July 1982.

QUILLIAM, MAY, late of Gippsland Base Hospital, Sale, widow, died 25 June 1982.

SMITH, JESSIE MARY, also known as Jessie Mary Bottomley, late of Flat 190/150 Inkerman Street, St. Kilda, machinist, died 15 April 1982.

SULLIVAN, THOMAS PATRICK, late of Kew, pensioner, died 16 July 1982.

I hereby give notice that on 22 September 1982 the Public Trustee filed Elections to Administer the following deceased persons' estates in accordance with section 17 of the *Public Trustee Act 1958*.

BREARLEY, VICTOR, late of Bundoora, miner, died 25 May 1982.

KENNAN, IRENE DORIS, late of Unit 3, 3 Farrington Street, Pascoe Vale, widow, died 15 July 1982.

MOYLAN, JOHN, late of Ballarat, pensioner, died 1 July 1982.

PREECE, GEORGE WILLIAM, late of 14 Frederick Street, Thomastown, police pensioner, died 6 July 1982.

SIKORSKI, ZYGMUNT, late of 33 Church Street, Werribee, fencer, died 14 June 1982.

P. T. SPENCER
Public Trustee

168 Exhibition Street, Melbourne, 3000
29 September 1982

Creditors, next of kin, and others having claims against the estate of any of the under-mentioned deceased persons are required to send particulars of their claims to the Public Trustee, 168 Exhibition Street, Melbourne, Vic. 3000, the personal representative, on or before 13 December 1982, after which date the Public Trustee may convey or distribute the assets having regard only to the claims of which the Public Trustee then has notice:

BARTHOLOMEW, BERYL AGNES, late of 4 Adamson Street, Heidelberg, married woman, died 16 April 1982.

BREARLEY, VICTOR, late of Bundoora, miner, died 25 May 1982.

FRASER, ANGUS, late of Room 5/55 Linda Crescent, Hawthorn, pensioner, died 5 August 1982.

HARFORD, GRACE, formerly known as Grace Findlater, late of Flat 75/332 Park Street, South Melbourne, pensioner, died 13 July 1982.

HOURLIGAN, JOHN JOSEPH, formerly of 26 Hutchinson Street, East Brunswick, but late of St. Joseph's Home, St. George's Road, Northcote, retired driver, died 30 June 1982.

KENNAN, IRENE DORIS, late of Unit 3, 3 Farrington Street, Pascoe Vale, widow, died 15 July 1982.

MALAMIN, MICHAEL, late of 51 Grey Street, St. Kilda, pensioner, died 28 July 1982.

MOYLAN, JOHN, late of Ballarat, pensioner, died 1 July 1982.

PREECE, GEORGE WILLIAM, late of 14 Frederick Street, Thomastown, police pensioner, died 6 July 1982.

QUILLIAM, MAY, late of Gippsland Base Hospital, Sale, widow, died 25 June 1982.

SIKORSKI, ZYGMUNT, late of 33 Church Street, Werribee, fencer, died 14 June 1982.

SMITH, JESSIE MARY, also known as Jessie Mary Bottomley, late of Flat 190/150 Inkerman Street, St. Kilda, machinist, died 15 April 1982.

SULLIVAN, THOMAS PATRICK, late of Kew, pensioner, died 16 July 1982.

Melbourne, 29 September 1982

P. T. SPENCER
Public Trustee

PLACE NAMES COMMITTEE

Survey Co-ordination Act 1958

NOTIFICATION OF ASSIGNMENT OF NAME

The Place Names Committee hereby gives notice that, pursuant to the several provisions of the *Survey Co-ordination Act 1958*, the undermentioned names are assigned:

Ref.	Municipality	Name Assigned	Location
M008/1	Shire of Bacchus Marsh	Long Forest Flora Reserve	} As given in the Committee's notice published in the <i>Victoria Government Gazette</i> , No. 62, dated 23 June 1982
M163/1	City of Caulfield	Caulfield Park Shopping Centre	
M185/6	City of Melbourne	Batman Park	
M141/1	Town of Portland	Bundarra Primary School	} As given in the Committee's notice published in the <i>Victoria Government Gazette</i> , No. 43, dated 5 May 1982
	Shire of Sherbrooke	Violet Larsen Reserve	
	Shire of Warrnambool	The W. P. O'Sullivan Playground	As given in the Committee's notice published in the <i>Victoria Government Gazette</i> , No. 33, dated 7 April 1982

NOTIFICATION OF PROPOSAL TO ALTER NAME

The Place Names Committee hereby gives notice that, pursuant to the several provisions of the *Survey Co-ordination Act 1958*, it proposes to alter the undermentioned name, in the manner indicated. Any objection to this proposal must be in writing, state the reasons for objection, and be lodged with the Committee on or before 8 November 1982.

Ref.	Municipality	Present Name	Proposed Name
M159/2	City of Broadmeadows	Westmeadows Heights High School	Erinbank High School

P. G. SEWELL, Secretary

Place Names Committee
Department of Crown Lands and Survey
2 Treasury Place
Melbourne 3002

Industrial Relations Act 1979

NOTICE OF APPLICATION FOR RECOGNITION AS AN ASSOCIATION

Notice is hereby given that the Country Fire Authority Officers Association has filed an application to be recognized as an association under the *Industrial Relations Act 1979* with respect to the trade or trades for which the Vehicle Building Industry Conciliation and Arbitration Board has been appointed.

Pursuant to regulation 33 (5) of the *Industrial Relations Regulations* any recognized association or person interested may on or before 5 November 1982 file in the Registry (9th Floor, 271 William Street, Melbourne) an objection to the application.

The objection shall be in, or to the effect of Form 9 prescribed by the Regulations.

A. S. DOWLING, Deputy Registrar
Industrial Relations Commission of Victoria

*Industrial Training Act 1975*INDUSTRIAL TRAINING COMMISSION OF VICTORIA
NOTICE OF INTENTION TO RECOMMEND THAT THE TRADE OF SPRINKLER FITTING—FIRST CLASS BE PROCLAIMED AN APPRENTICESHIP TRADE

Notice is hereby given, in pursuance of the provisions of the *Industrial Training Act 1975*, that it is the intention of the Industrial Training Commission of Victoria to recommend to the Minister for Employment and Training that the trade of Sprinkler Fitting—First Class be proclaimed to be an apprenticeship trade under the said Act.

It is also notified that 1 November 1982 has been fixed as the date before which representations may be made to the said Commission, by or on behalf of employers or employees in the said trade whether for or against the said trade being so proclaimed.

By order of the Commission
K. GRIFFITHS
Secretary to the Commission

80 Collins Street, Melbourne, 3000

DEPARTMENT OF PLANNING

CORRIGENDUM

Government Gazette No. 84, dated 25 August 1982
Page 2799—Shire of Lilydale Planning Scheme Revocation No. 44—

Delete "Lot 2, L.P.1216009 Kellybrook Winery, Fulford Road, Wonga Park"; insert "Lot 2, L.P.116009 Kellybrook Winery, Fulford Road, Wonga Park".

Government Gazette No. 90, dated 8 September 1982
Page 2990—Melbourne Metropolitan Planning Scheme Amendment No. 173 Part 1A—

Delete "In respect of the municipal district of the City of Keilor"; insert "In respect of various municipal districts".

A. B. KELLOCK, Manager
Port Phillip Division

NOTICE TO MARINERS

[No. 48 OF 1982]

AUSTRALIA—VICTORIA

WESTERNPORT

Buoy Withdrawn

Former Notice—No. 41T of 1982 refers.
McHaffies Reef buoy, Lat. 38 deg. 27 min. 42 sec. S., Long. 145 deg. 09 min. 38 sec. E. has been permanently withdrawn.

Chart Affected—AUS. 156.

Publication Affected—*Sailing Directions, Victoria 1970*, page 345.

A. J. WAGGLEN
Port Officer

Public Works Department
Ports and Harbors Division
168 Exhibition Street
Melbourne, 3000, 27 September 1982

NOTICE TO MARINERS

[No. 47r of 1982]

AUSTRALIA—VICTORIA

PORT OF GIPPSLAND LAKES

Lakes Entrance—Dredging Works

1. North Arm—To be completed.
2. Cunninghame Arm—To commence.

Date—On or about 29 September 1982.

Former Notice—No. 30 (τ) of 1982 will be cancelled.

Details—1. Dredging operations at the entrance to North Arm will be completed.

2. Dredging operations will commence and continue during daylight hours only at the entrance to Cunninghame Arm.

A dredger will be moored at the entrance and will have attached to it a pipeline leading to the southern shore.

Vessels wishing to navigate the entrance to Cunninghame Arm whilst the pipeline is in position should expect to wait until the pipeline is opened at irregular intervals depending on the volume of traffic.

During dredging operations a narrow channel will be open between Bullock Island and the dredger but this channel will allow single vessel navigation in one direction only until the channel is further widened as dredging proceeds.

Attention is drawn to Paragraph (3) of the Port Rule (Port of Gippsland Lakes Navigation of Entrance) 1982 which states—

“The Master of a vessel when departing Cunninghame Arm shall keep out of the way of every vessel navigating Reeves Channel.”

A. J. WAGGLEN
Port Officer

Public Works Department
Ports and Harbors Division
168 Exhibition Street
Melbourne, 3000, 24 September 1982

NOTICE TO MARINERS

[No. 49r of 1982]

AUSTRALIA—VICTORIA

WESTERNPORT

North Arm Buoyed Channel Shoaling

A least depth of 13.5 metres exists 335 deg. distant 670 metres from No. 19 buoy. Depths between 13.5 metres and 14.1 metres extend across the channel in a narrow band adjacent to this position.

Depths of 13.9 metres exist close to the eastern limit of the channel 80 metres southward of No. 21 buoy and close to the western limit of the channel 385 metres southward of No. 22 buoy.

Isolated patches with depths between 14 metres and 14.2 metres exist on the eastern side of the channel between Nos. 19 and 23 buoys.

Dredging works will be undertaken.

A. G. WAGGLEN
Port Officer

Public Works Department
Ports and Harbors Division
168 Exhibition Street
Melbourne 3000, 28 September 1982

Town and Country Planning Act 1961

MELBOURNE METROPOLITAN PLANNING SCHEME

AMENDMENT No. 156, PART 2

Notice of Approval

In pursuance of the powers conferred by the *Town and Country Planning Act 1961*, the Governor in Council on 28 September 1982, approved a planning scheme entitled the Melbourne Metropolitan Planning Scheme, Amendment No. 156, Part 2 and such planning scheme comes into operation on the date this Notice of Approval is published in the *Government Gazette*.

A copy of the Planning Scheme as approved may be inspected free of charge, during office hours, at the office of the Department of Planning, 235 Queen Street, Melbourne, at the office of the Melbourne and Metropolitan Board of Works, 625 Little Collins Street, Melbourne, and when available, at the Office of Titles, Melbourne, and at the Central Plan Office of the Department of Crown Lands and Survey, Melbourne.

DAVID YENCKEN
Secretary for Planning

Town and Country Planning Act 1961

MELBOURNE METROPOLITAN PLANNING SCHEME

AMENDMENT No. 220

Notice of Amendment

In pursuance of the powers conferred by sub-section 6 of section 32 of the *Town and Country Planning Act 1961*, the Governor in Council, on 28 September 1982, amended the Melbourne Metropolitan Planning Scheme to allow for the erection of detached houses (without permit) on specified land at Little River in the Shire of Werribee.

A copy of the Amendment may be inspected during office hours at the office of the Department of Planning at 235 Queen Street, Melbourne, at the office of the Melbourne and Metropolitan Board of Works, 625 Little Collins Street, Melbourne and when available at the Office of Titles, Melbourne, and at the Central Plan Office of the Department of Crown Lands and Survey, Melbourne.

DAVID YENCKEN
Secretary for Planning

Town and Country Planning Act 1961

SHIRE OF BALLARAT PLANNING SCHEME

AMENDMENT No. 13

Notice of Amendment

In pursuance of the powers conferred by sub-section 6 of section 32 of the *Town and Country Planning Act 1961*, the Governor in Council, on 28 September 1982, amended the Shire of Ballarat Planning Scheme.

The amendment allows the Responsible Authority to grant a permit for the construction of an office of a Professional Person (Accountant's Offices) on Lot 5, Lodged Plan 133816, Parish of Dowling Forest, Western Highway, Ballarat.

A copy of the Amendment may be inspected during office hours at the office of the Department of Planning at 235 Queen Street, Melbourne, at the office of the Council of the Shire of Ballarat, Gillies Street, Wendouree, and when available at the Office of Titles, Melbourne, and at the Central Plan Office of the Department of Crown Lands and Survey, Melbourne.

DAVID YENCKEN
Secretary for Planning

Town and Country Planning Act 1961

SHIRE OF YEA PLANNING SCHEME 1979

AMENDMENT No. 4

Notice of Amendment

In pursuance of the powers conferred by sub-section 6 of section 32 of the *Town and Country Planning Act 1961*, the Governor in Council, on 28 September 1982, amended the Shire of Yea Planning Scheme 1979, so as to include the use “Ambulance Station” as a consent use in the Residential A Zone.

A copy of the Amendment may be inspected during office hours at the office of the Department of Planning at 235 Queen Street, Melbourne, at the office of the Council of the Shire of Yea at Yea and when available at the Office of Titles, Melbourne, and at the Central Plan Office of the Department of Crown Lands and Survey, Melbourne.

DAVID YENCKEN
Secretary for Planning

APPOINTMENTS AND RESIGNATIONS

APPOINTMENTS

His Excellency the Governor of the State of Victoria, by and with the advice of the Executive Council thereof, has by Orders made on 28 September 1982 been pleased to make the under-mentioned appointments, viz.:

DEPARTMENT OF COMMUNITY WELFARE SERVICES

Honorary Probation Officers

DOROTHY AVENT, 12 Magnolia Street, Oak Park,
EILEEN BLYTHE, 72 Cooper Street, Essendon,
GAIL RUBY BUCKLEY, 38 Hartington Street, Glenroy,
VIOLA ROSE BOAG, 34 Tatura Crescent, Broadmeadows,
PETER JOHN CHRISTIE, 281 Carrick Drive, Tullamarine,
KERRY JOHN COCKS, 36 Elliott Avenue, Broadmeadows,
MARALANN ADA DAMIANO, 14 Margaret Street, Oak
Park,
JANICE MAY GIRVAN, 1 Bradley Street, Broadmeadows,
JOHN SAMUEL HANDFORD, 23 Hastings Crescent, Broad-
meadows,
DONNA MARIE HARGREAVES, 101 Vincent Street, Oak
Park,
AMANDA HASTINGS, 15 Darebin Court, Coolaroo,
OLIVE KING, 118 Mickleham Road, Tullamarine,
TERENCE JOHN LEWIS, 1/139 East Street, Glenroy,
SUSAN ELIZABETH MCGINLEY, 9 Redan Court, West-
meadows,
CAROLE MAREE MORAN, Unit 5, 89 Station Road, Glenroy,
JOHN PETER SLEINIS, 4/883 High Street, East Kew,
JENNY SMITH, 24 Rennie Street, Coburg,
THOMAS ARTHUR SPORTON, 20 Day Street, Broadmeadows,
AUDREY MARY STOKES, 10 Dunn Street, Broadmeadows,
MARTIN DIXON, 60 Davey Street, Frankston,
JANET MARY DONNELL, 32 Hilton Street, Glenroy,
ROBERT JAMES DUELL, 4 Hadfield Court, Broadmeadows,
BERNARD GEORGE DRENNAN, 46 Cosmos Street, Glenroy,
MAREE EGOROFF, 12 Anne Street, Broadmeadows,
PETER JOHN BROCK, 932 Doncaster Road, East Doncaster,
ANNE MAREE DELANEY, Kew,
CHERRY FULLER, 19 Wellesley Road, Glen Waverley,
MARY FRANCES GRIFFIN, Mistletoe Street, Golden Square,
CHERRYL MARION HUMPHRIES, 6 St. John's Wood Road,
Mount Waverley,
NOEL TERRENCE KIMBERLEY, 4 Gungarlan Drive, East
Keilor,
RITA BRIGITTE KRISTOF, 12 Eemon Road, North Balwyn,
ANN ELIZABETH MARRIOTT, 5 Cranleigh Grove, Mount
Waverley,
INGID B. MATHEW, 23 The Ridge, Canterbury,
GARY THOMAS O'CONNOR, 2/6 A'Beckett Street, Kew,
SALLY-ANNE MAREE THOMPSON, 26 Sylvia Street, Lower
Templestowe,
JILL YOUNG, 83 Lea Road, Mulgrave,
DEBORAH JAN BOWMAN, "Homebush", Glanville Road,
Echuca Village, Echuca,
ERIC JAMES MORGAN, 5 Carlos Court, North Shepparton,
ADELE WINIFRED SCHEFFER, 15 Boyle Street, Echuca,
BARBARA ELAINE STRATTON-ALCORN, 91 Rea Street, Shep-
parton, and
ROBERT FRANCIS WOOD, 115 Corinella Crescent, Dallas,
to be Honorary Probation Officers for all Adult and
Children's Courts in the State of Victoria, pursuant to the
provisions of section 507 (2) of the *Crimes Act 1958*, and
section 9 of the *Children's Court Act 1973*.

HEALTH COMMISSION

Members of Committees of Management of Hospitals

JOHN EDWARD CLEMENTS,
Ballarat Base Hospital, 31 August 1985;
HERBERT JOHN BUTCHER,
GEOFFREY JOHN COHEN, and
RODNEY JAMES FLETCHER,
Castlemaine District Community Hospital, 31 August
1985;
ELISABETH WESTON CAMERON,
ADRIAN CORNELIUS BUNNIK, and
LAWRENCE JAMES MCGRATH,
Casterton Memorial Hospital, 31 August 1985;

HARRY WILLIAM GARLICK,
STANLEY IAN JUNGWIRTH, and
JANICE ST. JOHN BATE,
Prince Henry's Hospital, 31 August 1985;
STANISLAUS CARROLL,
DONALD ARMAGH JENKINS,
REGINALD ROBERT SOBEY, and
DAVID CHITTICK,
Warrnambool and District Base Hospital, 31 August
1985;
ROBERT GEORGE CHISHOLM,
JAMES FRANCIS NEAGLE,
WILLIAM GRAHAM SYMON, and
ROBERT GRANVILLE WARD,
Hampton Hospital, 30 September 1982-31 August 1985;
DONALD GRAEME TURRIFF CAMERON,
Hampton Hospital, 28 September 1982-31 August 1984;
to be Members of the Committee of Management of the
abovementioned Hospitals pursuant to the provisions of
section 63F (1) of the *Hospitals and Charities Act 1958*
for the period of office expiring on the dates indicated.

Trustees of Public Cemeteries

DONALD WILLIAM DUNCAN
to be a Trustee of the Toongabbie Public Cemetery, new
Trustee;
COLIN CAMPBELL
to be a Trustee of the Tungamah Public Cemetery, new
Trustee;
ALAN MCBETH
to be a Trustee of the Castlemaine Public Cemetery, new
Trustee;
PHILLIP TEMPLETON,
JOHN SCOUGALL,
BRUCE BEATTIE, and
GERARD MCKAY,
to be Trustees of the Chinkapook Public Cemetery, new
Trustees; all appointed pursuant to section 3 (1) of the
Cemeteries Act 1958.

Member of the Dental Technicians Licensing Committee

TREVOR KNIGHT
as a Member of the Dental Technicians Licensing Com-
mittee pursuant to the provisions of section 3 of the
Dental Technicians Act 1972 for the period ending 7 May
1985.

LAW DEPARTMENT

Justices of the Peace

GRAEME GEOFFREY BRIANT, 3 Cherry Orchard Rise, Box
Hill North,
KEITH WILLIAM CLAUGHTON, City of Croydon, Foch
Avenue, Croydon, and
BRENDON JOHN MOLONY, 168 Exhibition Street, Mel-
bourne,
to be Justices of the Peace for the State of Victoria.

Children's Court Magistrate

GRAHAM JOSEPH COLLINS, Clerk of Courts, Class "CC-4",
Second Division,
to be a Children's Court Magistrate pursuant to section 5
of the *Children's Court Act 1973* as from 4 October 1982,
vice M. F. Moloney.

DEPARTMENT OF PROPERTY AND SERVICES

Members and Chairman of the Public Records Advisory Council

Professor ALAN GEORGE LEWERS SHAW, B.A. (Hons.),
M.A. (Oxon.), F.A.H.A., F.A.S.S.A.,
to be a Member and Chairman of the Public Records
Advisory Council for a period of three years ending 15
October 1985 pursuant to section 4 of the *Public Records
Act 1973*.
JOHN NEIL MCAULEY,
JOHN DANIEL CAMERON, D.P.A.,
ALEXANDER MATHESON OWEN, B.A.,
PETER LYNN, M.A., B.A., Dip.Soc.Stud.,
WARREN MICHAEL HORTON, B.A., A.L.A.A., and
KEVIN DOWLING, J.P.,
to be Members of the Public Records Advisory Council
for a period of 3 years ending 15 October 1985 pursuant
to section 4 of the *Public Records Act 1973*.

PUBLIC WORKS DEPARTMENT

Wharf Manager

Senior Sergeant ROBERT JOHN FROOD, No. 12676, as Wharf Manager at Hastings. (a) To carry out that portion of Part II. of the *Marine Act 1958* which relates to the management of public wharfs. (b) To be an officer for the purpose of carrying out and enforcing rules and regulations made pursuant to section 7 of such Act, at a remuneration of \$140 per annum, vice Senior Sergeant John Alan Quirk, No. 13634, transferred—(P. & H. 21891).

TOM FORRISTAL
Clerk of the Executive Council

At the Executive Council Chamber
Melbourne, 28 September 1982

Liquor Control Act 1968

APPOINTMENT OF LICENSING INSPECTOR

In accordance with the authority conferred upon me by Section 6 of the *Police Regulation Act 1958*, I, John Roderick Hall, Deputy Commissioner of Police, do hereby appoint under sub-section (1) of Section 22 of the *Liquor Control Act 1968*, the following Officer of Police as a Licensing Inspector for the Division of the Police District as shown:

<i>Division Number</i>	<i>Police District</i>	<i>Rank and Name</i>
2	Melbourne	Inspector Adrian Ross Donehue (from 3.10.82 to 30.10.82).

30.9.1982
J. R. HALL
Deputy Commissioner

REVOCATION OF APPOINTMENTS

His Excellency the Governor of the State of Victoria, by and with the advice of the Executive Council thereof, has by Orders made on 28 September 1982 revoked the appointments of the persons named hereunder to the offices mentioned, viz.:

DEPARTMENT OF COMMUNITY WELFARE SERVICES
Honorary Probation Officers

GERARD FRANCIS BEASLEY,
LEONARD JOHN BLAIR,
JOHN BLINSTON,
JOHN FRANCIS BRADY,
TREVOR JOHN BULLED,
COLIN GORDON BURGESS,
PHILLIP LINTON BURGESS,
GEORGE CALLEJA,
MAURICE JAMES CARSE,
ARTHUR ROY CLARK,
NOEL KINGSLEY COCKINGS,
A. ELIZABETH CODOGNOTTO,
MARIE ANGNES CONROY,
MALCOLM LEONARD CRAWLEY,
NORMA WINSOME CURRELL,
ROBERT WILLIAM DAVIDSON,
GRAHAM N. CALLAN,
EDITH ELIZABETH COUGHLAN,
TIMOTHY FRANCIS DOYLE,
KENNETH MAXWELL EASDOWN,
GLENDA VIOLET JAMES,
KENNETH GEORGE PEARSON,
EDWARD CHRISTOPHER RYAN,
JOHN DAVIES,
ANNE ROSEMARY DE SALVO,
JANICE LOUISE FARRIN,
ELORA FEIGLIN,
GEORGE WILLIAM FINNIE,
JAMES PATRICK FLAIVE,
DONALD IAN FLEMING,
ARCHIE LIONEL FOSTER,
FRANCIS WILLIAM FRAWLEY,
ROBERT FRAZER,
HAROLD BENJAMIN FREEMAN,
LAWRENCE JOHN HODGES,
LAWRENCE VICTOR MAHON,
TERENCE JAMES O'BRIEN,
CHARLES PHILLIPS,
JOHN ROBERTS,
EVELYN ROTHFIELD,

NORMAN JOHN RYAN,
ALLAN HARVEY TASKER,
DONALD ALBERT VERCOE THOMAS,
IAN MURRAY THOMSON,
NEVILLE JOHN THULBORN,
JAMES HENRY TRELOR,
LYALL ALEXANDER TURLEY,
GENEVIEVE MARGAERITE WHITE,
DARYL LOETYS ARMSTRONG,
KAREN ARMSTRONG,
KEITH FRANCIS ARMSTRONG,
KINGSLEY ARMSTRONG,
ALFRED GEORGE AUSTIN,
PETER RICHARD BARNES,
WILLIAM JAMES DEERY,
JOHN DENIS DUFFUS,
JOSEPH AUGUSTINE DULLARD,
JOHN HENRY ETHERIDGE,
ANTHONY F. FEENEY,
BRIAN VINCENT FINNIGAN,
EDWARD JOHN FITZPATRICK,
BARRY REGINALD FLETCHER,
GERALD EDMOND GALLACHER,
JOHN GALLACHER,
MICHAEL JOSELAND,
HARRY KEAMY,
HELEN OLGA LIGHT,
BESSIE IVY FOLLIOTT SANDFORD,
ADRIANNE SCHREUDER,
KEYN SIDNEY SECOMB,
GADD SINCLAIR,
ANTHONY SKOROPLAS,
LAURANCE JOHN SLEE,
JILL SMITH,
MARTIN BARRY SMITH,
LINDSAY CAMPBELL SMITH-MOIR,
NORMA MAY SMITH,
WILLIAM GEORGE SMITH,
ROBERT WILLIAM JAMES TAYLOR,
SANDRA SAZANNE VAN KET WICH,
ALPHONSIUS PETRUS VAN SANTVOORT,
MARIA JACOBA VAN SANTVOORT,
DENIS ANDREW VARDON,
MAURINE JOY WRIGHT, and
PATRICK MICHAEL WYNNE,
as Honorary Probation Officers pursuant to the provisions of section 507 (2) of the *Crimes Act 1958* and section 9 of the *Children's Court Act 1973* for all Adult and Children's Courts in Victoria.

LAW DEPARTMENT

Commissioners for Taking Declarations, &c.

LUIGI CONDELLO,
IAN EDWARD PEGENHARDT,
AGNES ETHEL DORR,
IAN WILTON HAMMET,
REGINALD ARTHUR AUSTIN JAGER,
PATRICIA PETCH,
ERNEST ROY RANDELL,
HENRY PHILLIPS RILEY, and
WARREN BRUCE SHEARD,
as Commissioners for taking Declarations and Affidavits under the *Evidence Act 1958*.

TOM FORRISTAL
Clerk of the Executive Council

At the Executive Council Chamber
Melbourne, 28 September 1982

RESIGNATIONS

His Excellency the Governor of the State of Victoria, by and with the advice of the Executive Council thereof, has by Orders made on 28 September 1982 accepted the resignations of the persons named hereunder of the offices mentioned, viz.:

HEALTH COMMISSION

Member of Committee of Management of Hospital

THOMAS LANGLEY WEBB
as a Member of the Committee of Management of the Royal Victorian Eye and Ear Hospital as from 27 September 1982 in accordance with the provisions of section 63G (1) of the *Hospitals and Charities Act 1958*.

LAW DEPARTMENT
 Commissioner for Taking Declarations, &c.
 KEITH WILLIAM CLAUGHTON
 as a Commissioner for taking Declarations and
 Affidavits under the Evidence Act 1958.
 TOM FORRISTAL
 Clerk of the Executive Council
 At the Executive Council Chamber
 Melbourne, 28 September 1982

ORDERS IN COUNCIL

COUNTRY ROADS ACT 1958

At the Executive Council Chamber, Melbourne, the
 twenty-eighth day of September, 1982

PRESENT:

His Excellency the Governor of Victoria
 Mr Crabb Mr Simpson
 Mr Wilkes

ORDER CONFIRMING RESOLUTIONS OF THE
 COUNTRY ROADS BOARD

His Excellency the Governor of the State of Victoria,
 by and with the advice of the Executive Council thereof,
 doth hereby, in pursuance of the provisions of the Country
 Roads Act 1958, confirm the resolutions of the Country
 Roads Board, the dates whereof and the terms of which
 are scheduled hereunder:

SCHEDULE
 State Highways

Resolution dated 10 August 1982 made pursuant to
 section 70 (1) of the Country Roads Act 1958 rescinding
 resolutions of the Board declaring the Princes Highway in
 the Shire of Buln Buln as shown cross hatched on plans
 numbered G.P.539P1 and G.P.539P2 hereunder.

STATE HIGHWAY
 PRINCES HIGHWAY
 SHIRE OF BULN BULN

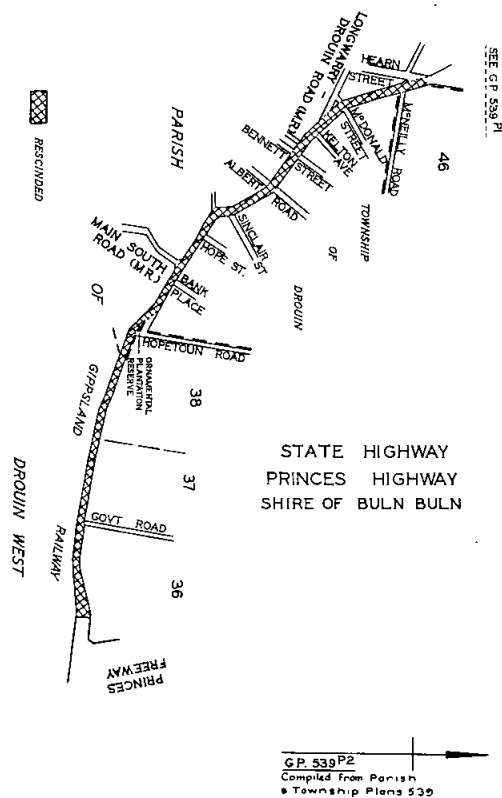
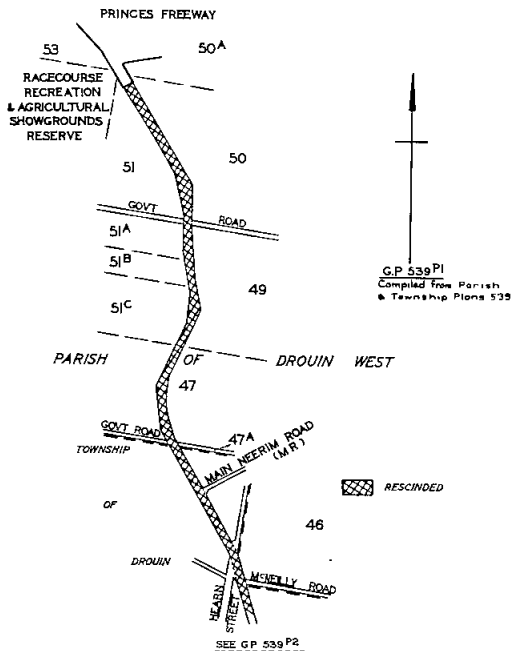

Resolution dated 24 May 1982 made pursuant to section
 70 of the Country Roads Act 1958 rescinding resolutions
 passed by the Country Roads Board and confirmed by
 Orders in Council published in the Government Gazettes
 of 8 July 1925 on pages 2371-3, 22 May 1929 on page
 1553 and 13 December 1944 on pages 3083-4, declaring
 the highway to be a State highway (Princes Highway)
 in the City of Moe, so far as it relates to the part of the
 said State highway indicated by cross hatching on plans
 numbered G.P.1101A and G.P.1101B hereunder.

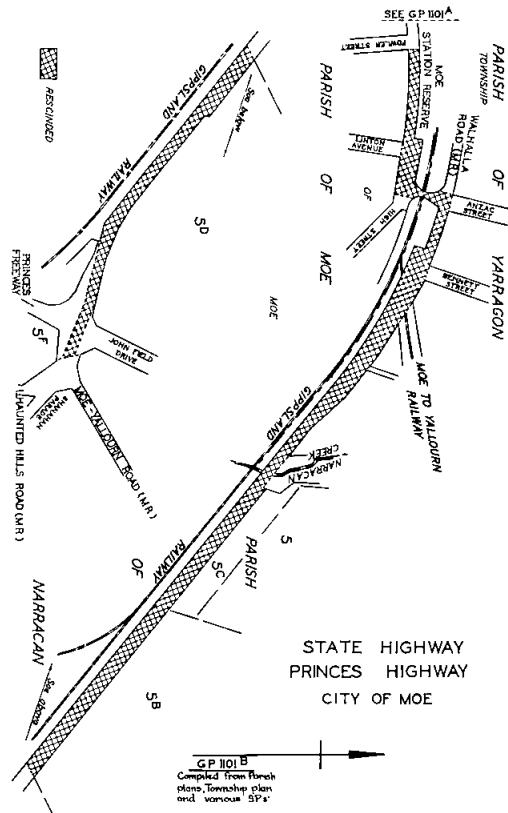
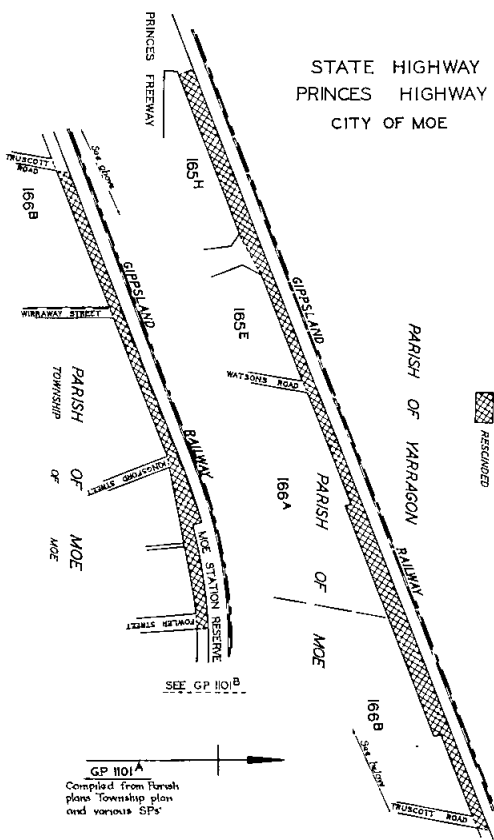

Main Roads

Resolution dated 10 August 1982 made pursuant to section 18 of the Country Roads Act 1958 declaring the highway in the Shire of Buln Buln as shown hatched on plans numbered G.P.539P3 and G.P.539P4 hereunder to be a main road (Drouin-Warragul Road) within the meaning and for the purposes of the said Act.

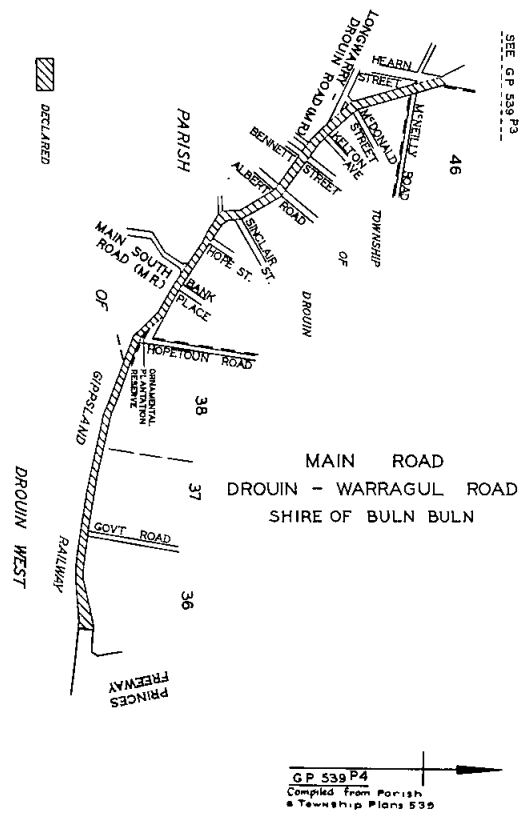
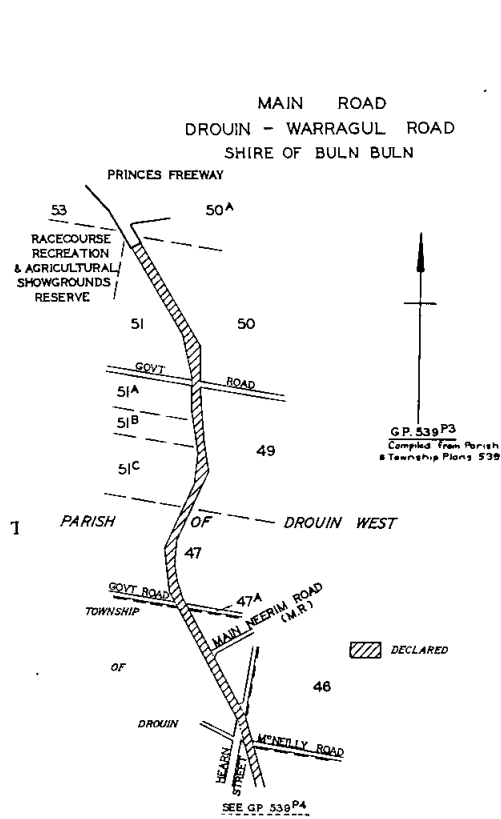

Resolution dated 21 June 1982 made pursuant to section 18 of the Country Roads Act 1958 rescinding the resolution passed by the Country Roads Board and confirmed by an Order in Council published in the *Government Gazette* of 2 September 1925 on page 2905 declaring the highway to be a main road (Longwarry-Drouin Road) in the Shire of Buln Buln so far as it relates to the part of the said main road indicated by cross hatching on plans numbered G.P.539T1 and G.P.539T2 hereunder.

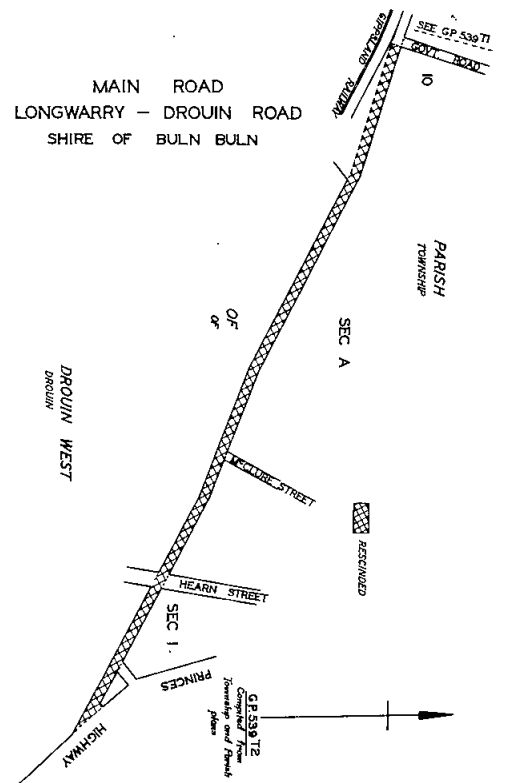
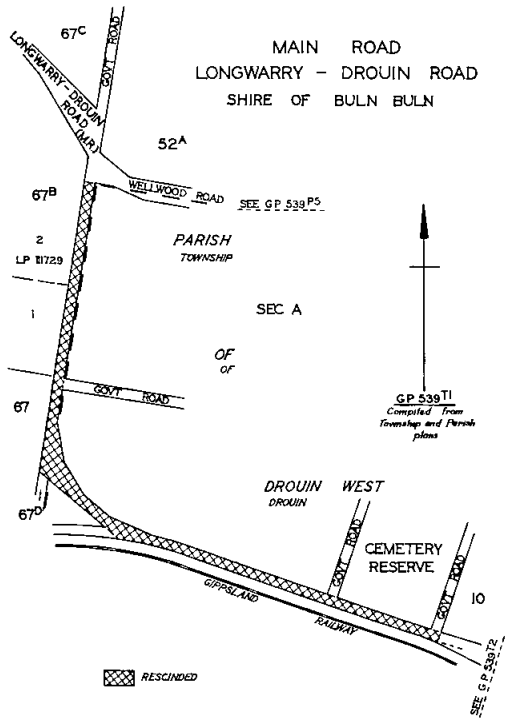

Resolution dated 21 June 1982 made pursuant to section 18 of the Country Roads Act 1958 rescinding the resolution passed by the Country Roads Board and confirmed by an Order in Council published in the *Government Gazette* of 21 September 1932 on page 2177 declaring the highway to be a main road (Neerim North Road) in the Shire of Buln Buln so far as it relates to the part of the said main road indicated by cross hatching on plan numbered G.P.989A hereunder.

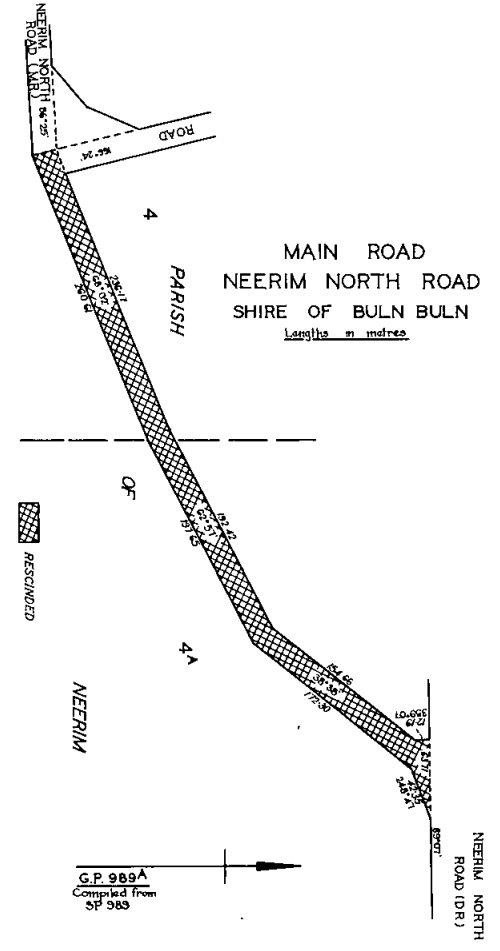

Resolution dated 21 June 1982 made pursuant to section 18 of the Country Roads Act 1958 declaring the highway in the Shire of Buln Buln as shown hatched on plan numbered G.P.539P5 hereunder to be a main road (Longwarry-Drouin Road) within the meaning and for the purposes of the said Act.

Resolution dated 24 May 1982 made pursuant to section 18 of the Country Roads Act 1958 declaring the highway in the City of Moe as shown hatched on plans numbered G.P.1101c and G.P.1101b hereunder to be a main road (Moe-Yallourn Road) within the meaning and for the purposes of the said Act.

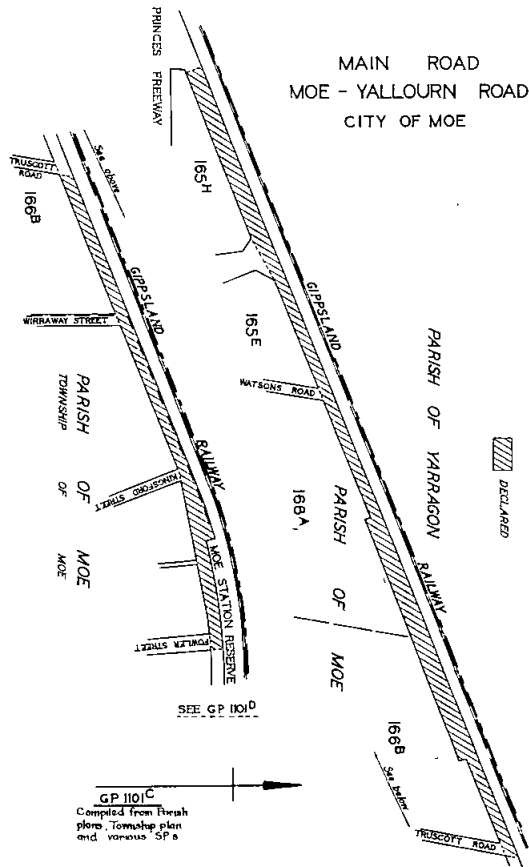
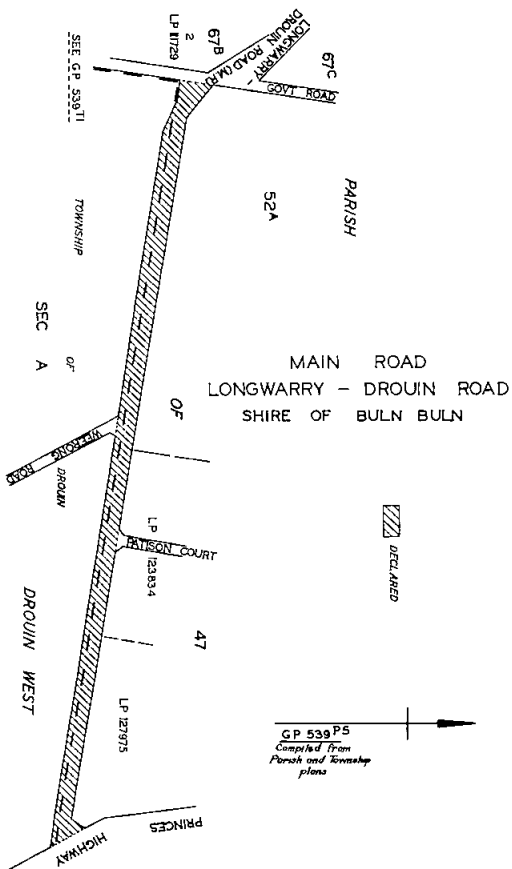

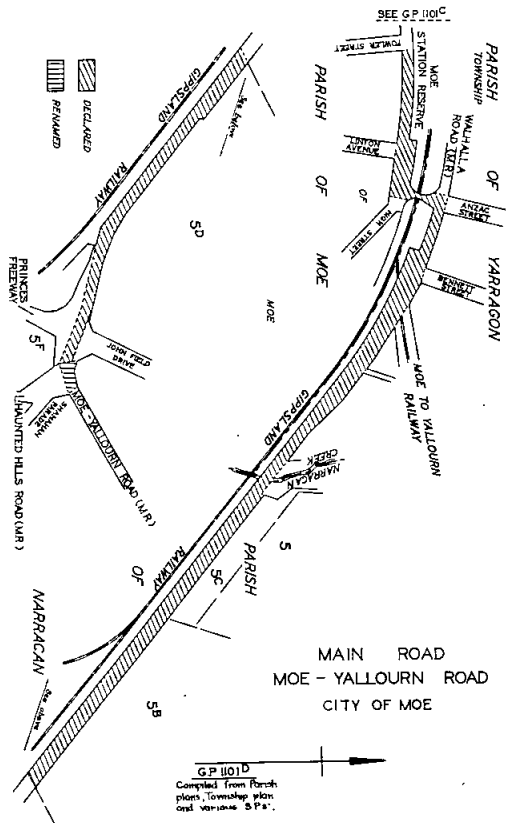

of 29 January 1941 on page 297 and 26 February 1941 on page 973 declaring the highway to be a main road (Wells Road) in the Cities of Springvale and Frankston so far as they relate to the part of the said main road indicated by horizontal hatching on plans numbered G.P.1000P1, G.P.1000P2, G.P.1000P3 and G.P.611P hereunder.

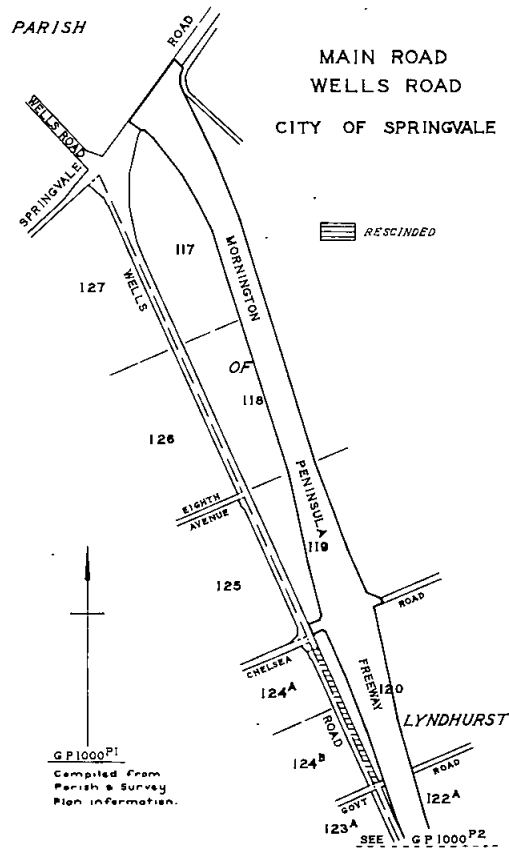

And the Honourable Steven Marshall Crabb, Her Majesty's Minister for Transport for the State of Victoria, shall give the necessary directions herein accordingly.

TOM FORRISTAL
Clerk of the Executive Council

COUNTRY ROADS ACT 1958

At the Executive Council Chamber, Melbourne, the twenty-eighth day of September, 1982

PRESENT:

His Excellency the Governor of Victoria
Mr Crabb | Mr Simpson
Mr Wilkes

ORDER CONFIRMING RESOLUTIONS OF THE COUNTRY ROADS BOARD

His Excellency the Governor of the State of Victoria, by and with the advice of the Executive Council thereof, doth hereby, in pursuance of the provisions of the Country Roads Act 1958, confirm the resolutions of the Country Roads Board, the dates whereof and the terms of which are scheduled hereunder.

SCHEDULE
Main Road

Resolution dated 18 May 1982 made pursuant to section 18 of the Country Roads Act 1958 rescinding the resolutions passed by the Country Roads Board and confirmed by Orders in Council published in the Government Gazettes No. 101—55580/82—3

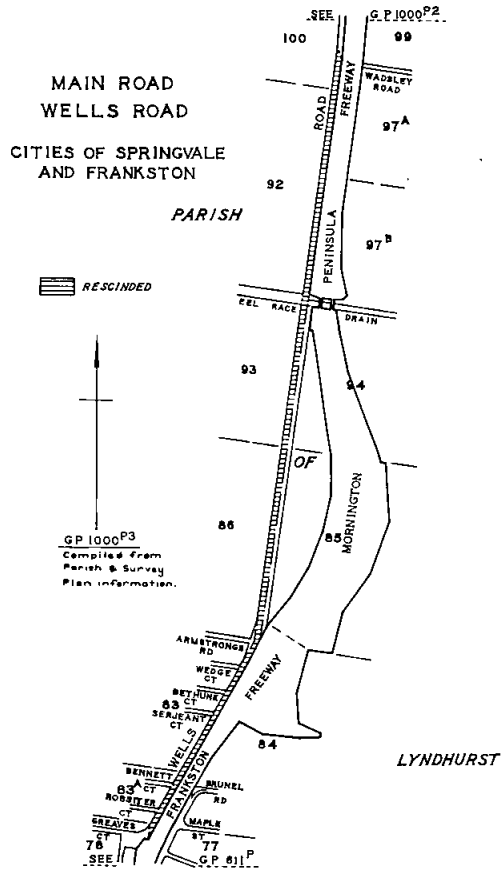
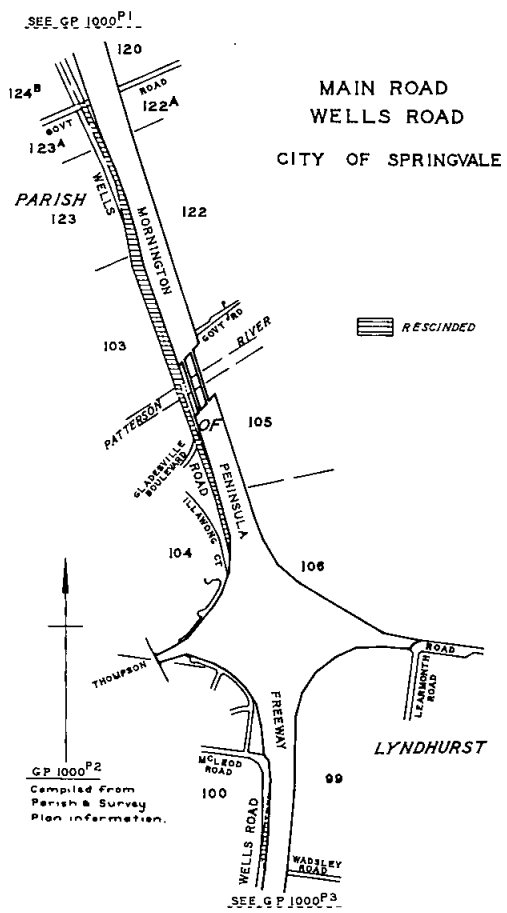

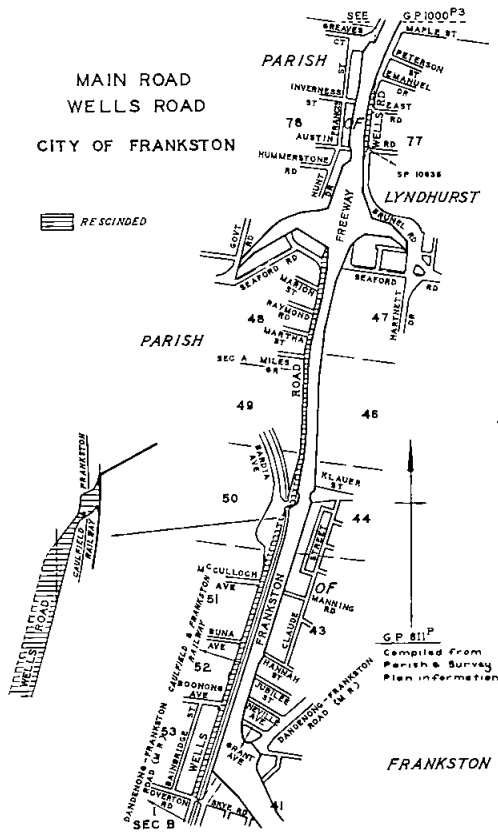

SCHEDULE
 Making of New Roads
 The land shown hatched on plans numbered G.P.15714 and G.P.15715A hereunder required for the Western Freeway in the Shire of Melton.

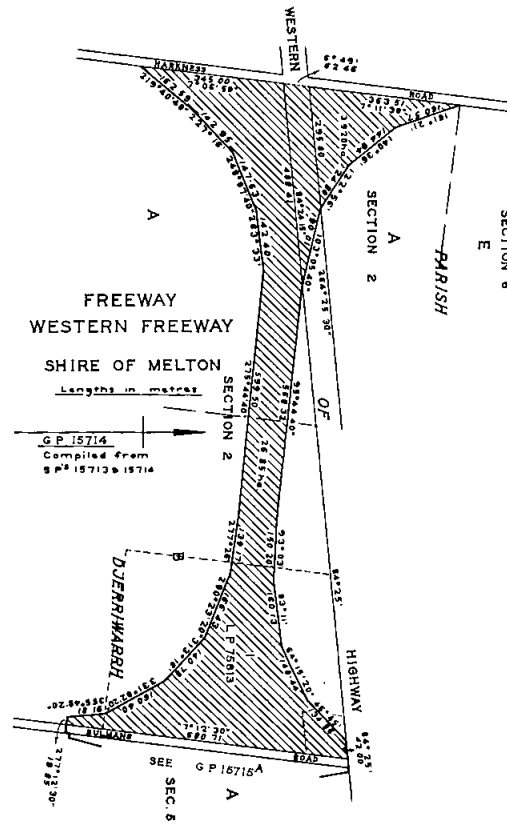

And the Honourable Steven Marshall Crabb, Her Majesty's Minister of Transport for the State of Victoria, shall give the necessary directions herein accordingly.

TOM FORRISTAL
 Clerk of the Executive Council

COUNTRY ROADS BOARD
 Act No. 6229

At the Executive Council Chamber, Melbourne, the twenty-eighth day of September, 1982

PRESENT:

His Excellency the Governor of Victoria
 Mr Crabb | Mr Simpson
 Mr Wilkes

ORDER APPROVING OF LAND BEING ACQUIRED AND ROADS, DEVIATIONS OR WIDENINGS BEING MADE TOGETHER WITH ALL ANCILLARY WORKS REQUIRED TO BE EXECUTED IN CONJUNCTION THEREWITH

His Excellency the Governor of the State of Victoria, by and with the advice of the Executive Council thereof, being satisfied that there are funds legally available for acquiring the land, doth hereby approve the acquiring of the land described in the Schedule hereunder and the making of new roads and deviations from and widenings of existing roads, together with all ancillary works required to be executed in conjunction therewith, referred to in the said Schedule.

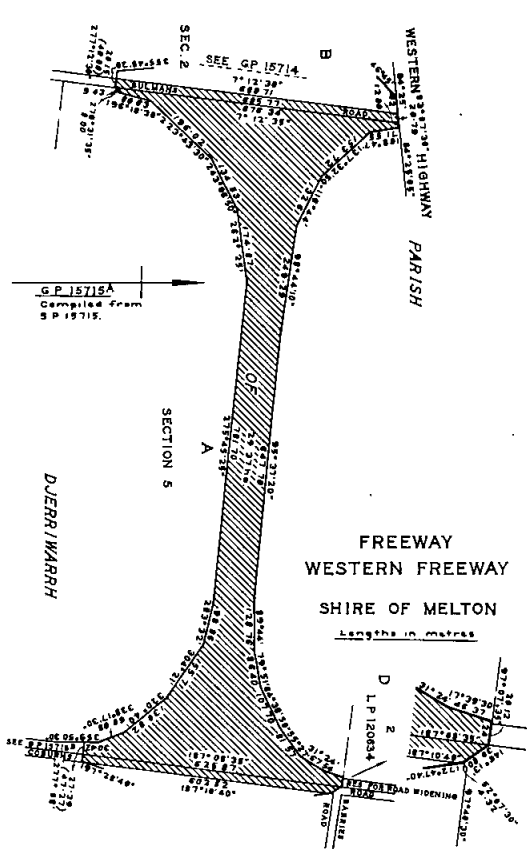

FREEWAY
MORNINGTON PENINSULA FREEWAY

CITY OF SPRINGVALE

Lengths in metres

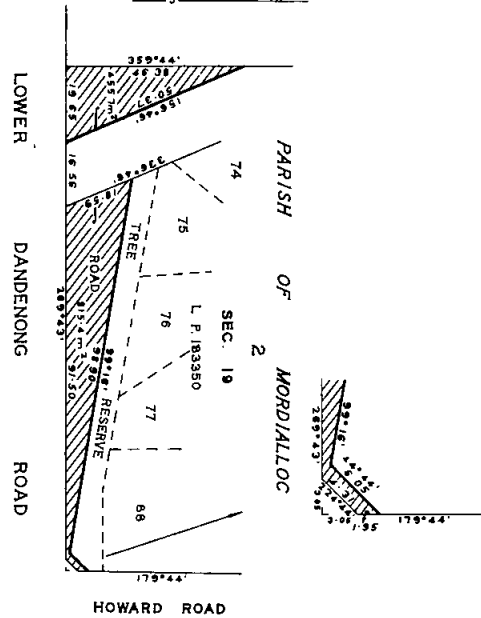

The land shown hatched on plan numbered G.P.15736 hereunder required for the Mornington Peninsula Freeway in the City of Springvale.

Widenings of Existing Roads

The land shown hatched on plan numbered G.P.15722 hereunder required for the Dandenong-Hastings Road in the Shire of Cranbourne.

MAIN ROAD
DANDENONG - HASTINGS ROAD
SHIRE OF CRANBOURNE
Lengths in metres

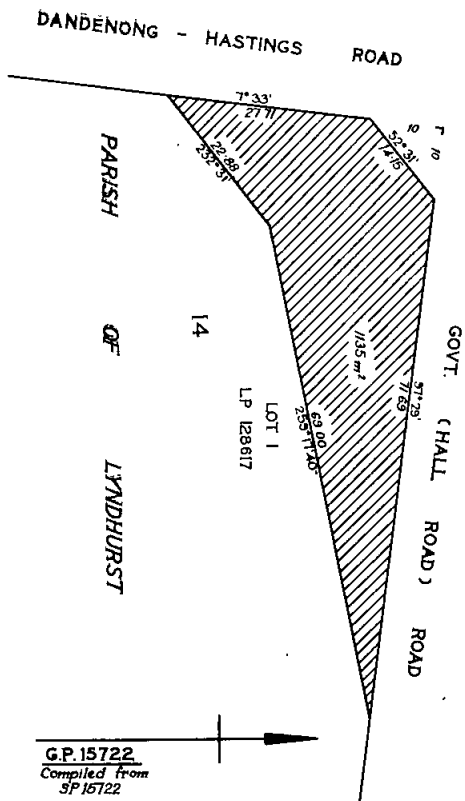

The land shown hatched on plans numbered G.P.15706A and G.P. 15706B hereunder required for the Murtoa-Minyip Road in the Shire of Dunmunkle.

MAIN ROAD
MURTOA - MINYIP ROAD
SHIRE OF DUNMUNKLE
Lengths in metres

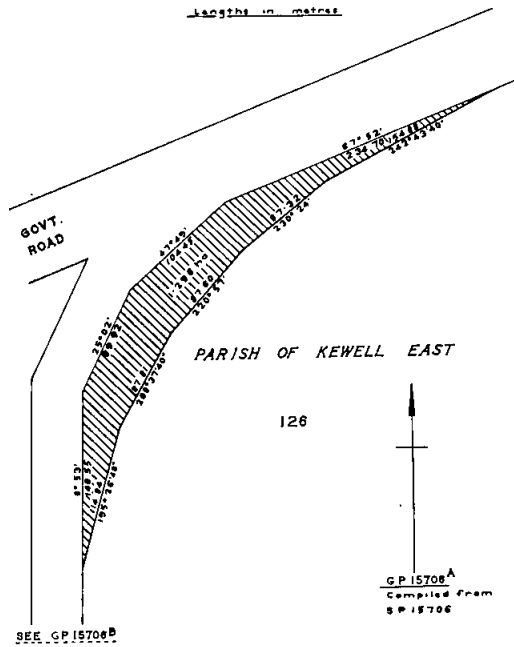

The land shown hatched on plan numbered G.P.15471 hereunder required for the Calder Freeway in the Shire of Gisborne.

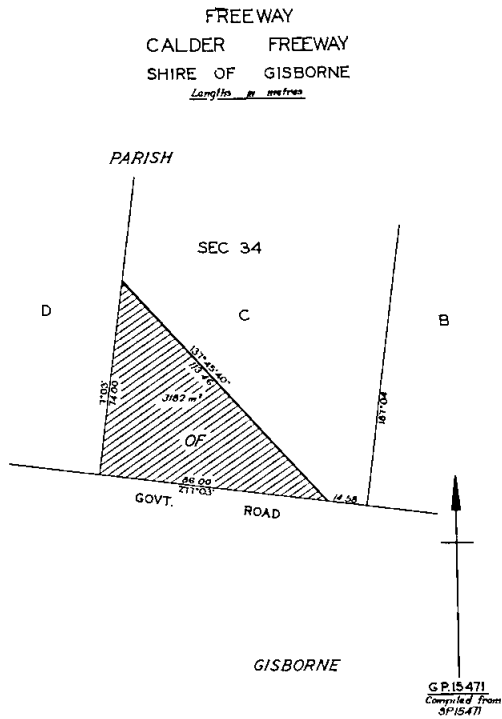
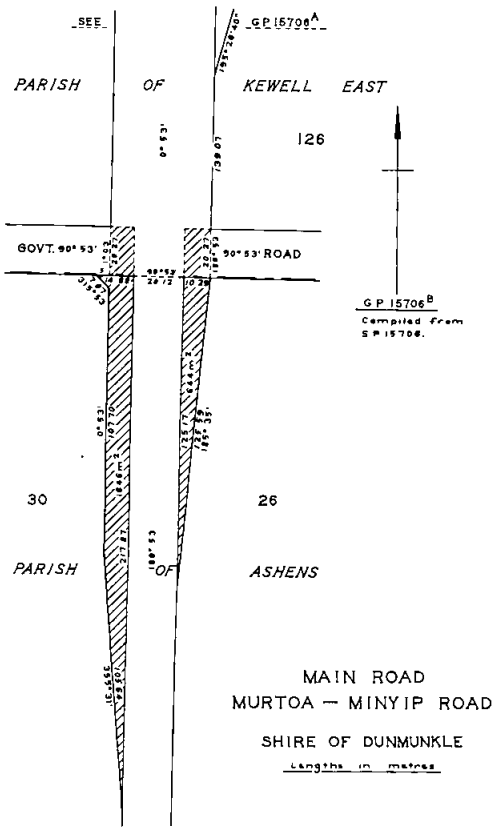

The land shown hatched on plan numbered G.P.15715B hereunder required for Coburns Road in the Shire of Melton.

The land shown hatched on plan numbered G.P.15607 hereunder required for the Hamilton-Port Fairy Road in the Shire of Minhamite.

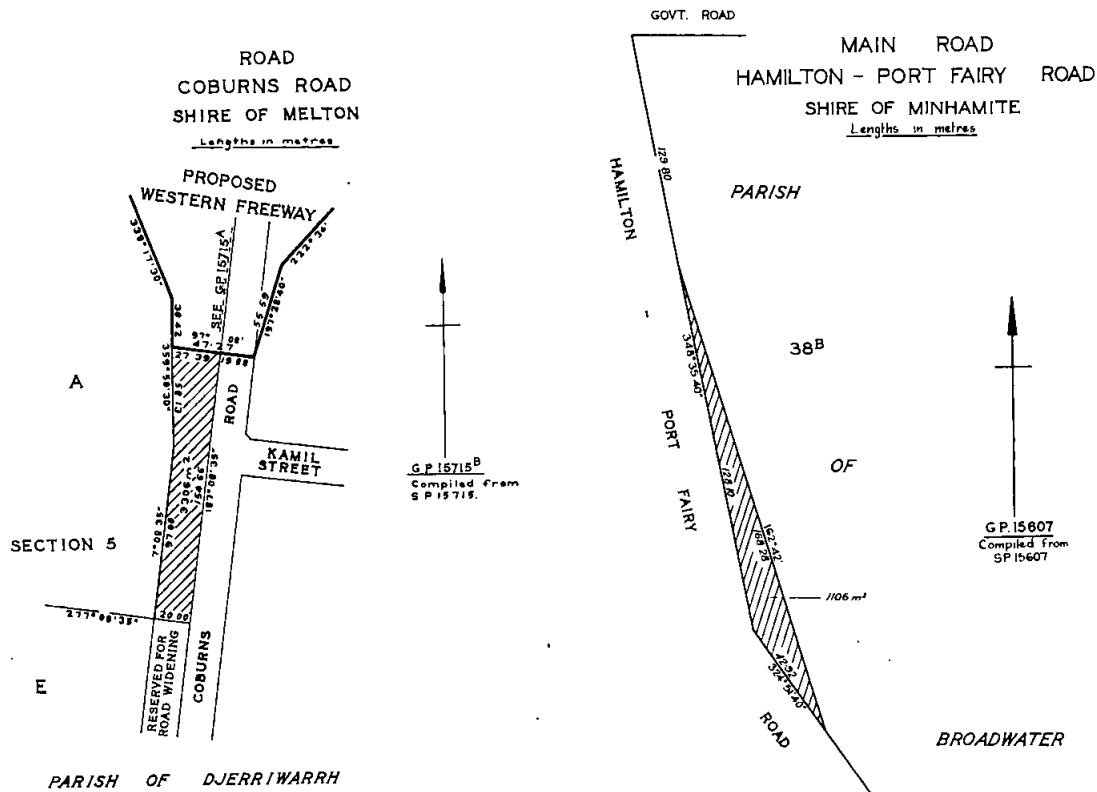

The land shown hatched on plan numbered G.P.15648A hereunder required for Old Marden Road in the Shire of Mirboo.

ROAD
OLD MARDAN ROAD
SHIRE OF MIRBOO
Lengths in metres

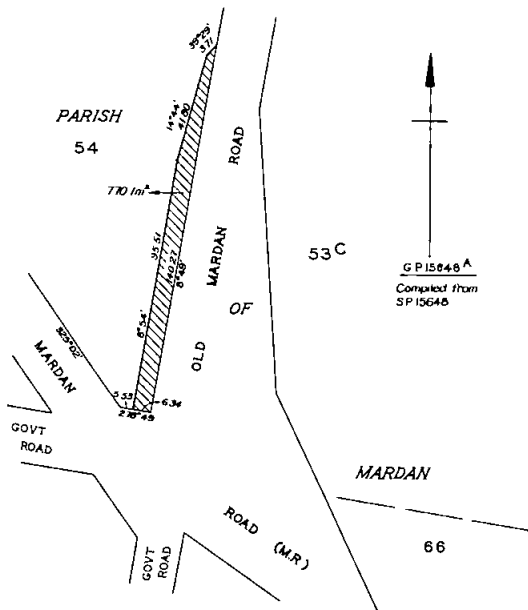

The land shown hatched on plan numbered G.P.15734 hereunder required for the Midland Highway in the City of Shepparton.

STATE HIGHWAY
MIDLAND HIGHWAY
CITY OF SHEPPARTON
Lengths in metres

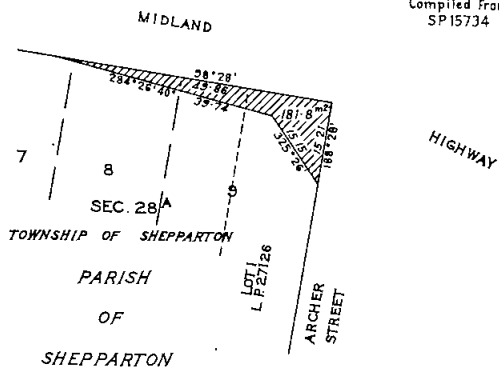

The land shown hatched on plan numbered G.P.15498A hereunder required for the Henty Highway in the Town of Portland and the Shire of Portland.

STATE HIGHWAY
HENTY HIGHWAY
TOWN AND SHIRE
OF PORTLAND
Lengths in metres

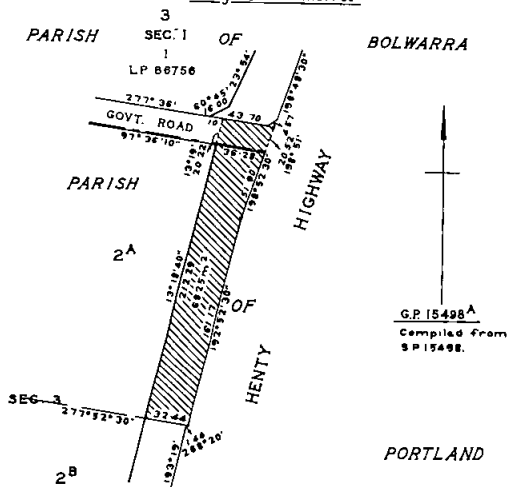

The land shown hatched on plans numbered G.P.15276A and G.P.15276B hereunder required for the Inverloch-Leongatha Road in the Shire of Woorayl.

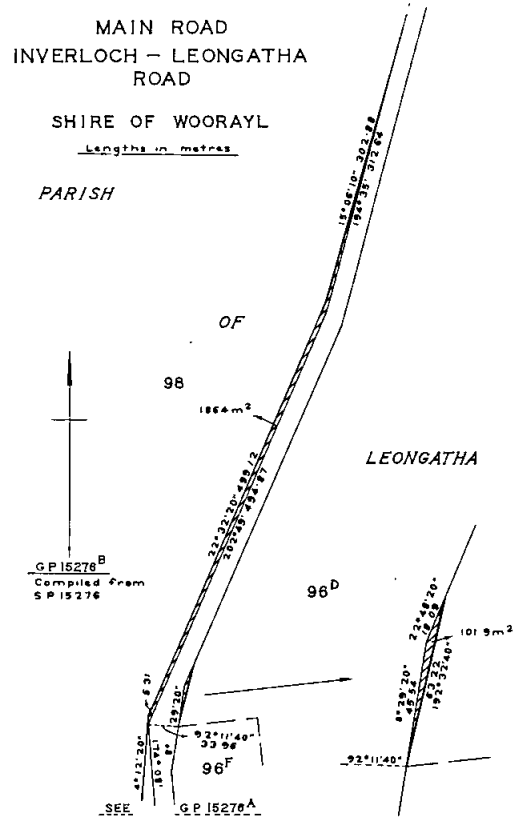
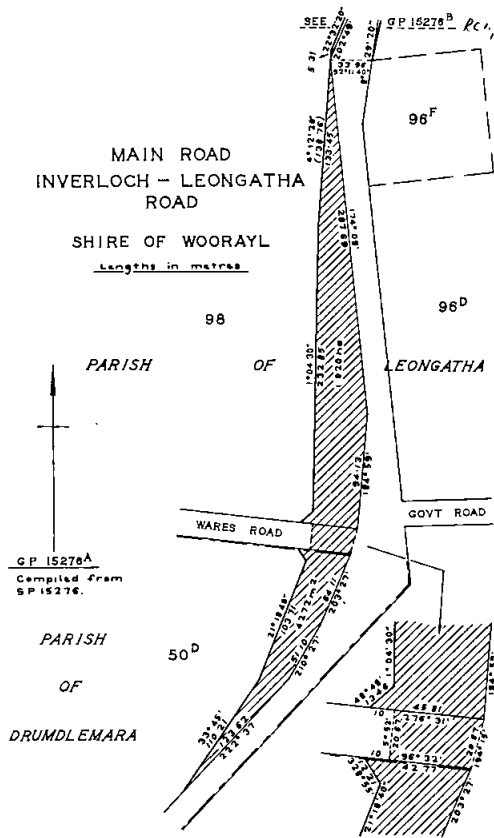

Deviations from Existing Roads

The land shown hatched on plans numbered G.P.15636A and G.P.15636B hereunder required for the Wimmera Highway in the Shire of Arapiles.

STATE HIGHWAY
WIMMERA HIGHWAY
SHIRE OF ARAPILES
Lengths in metres

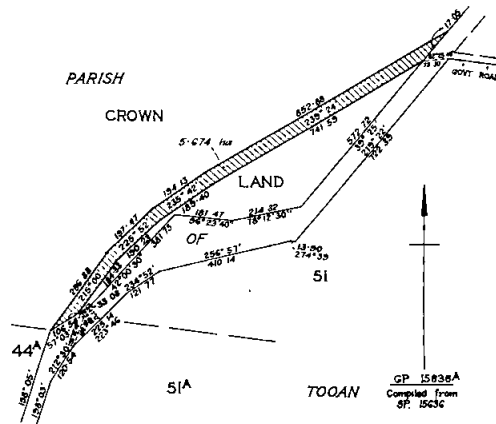

The land shown hatched on plan numbered G.P.15704A hereunder required for Charleys Creek Road in the Shire of Otway.

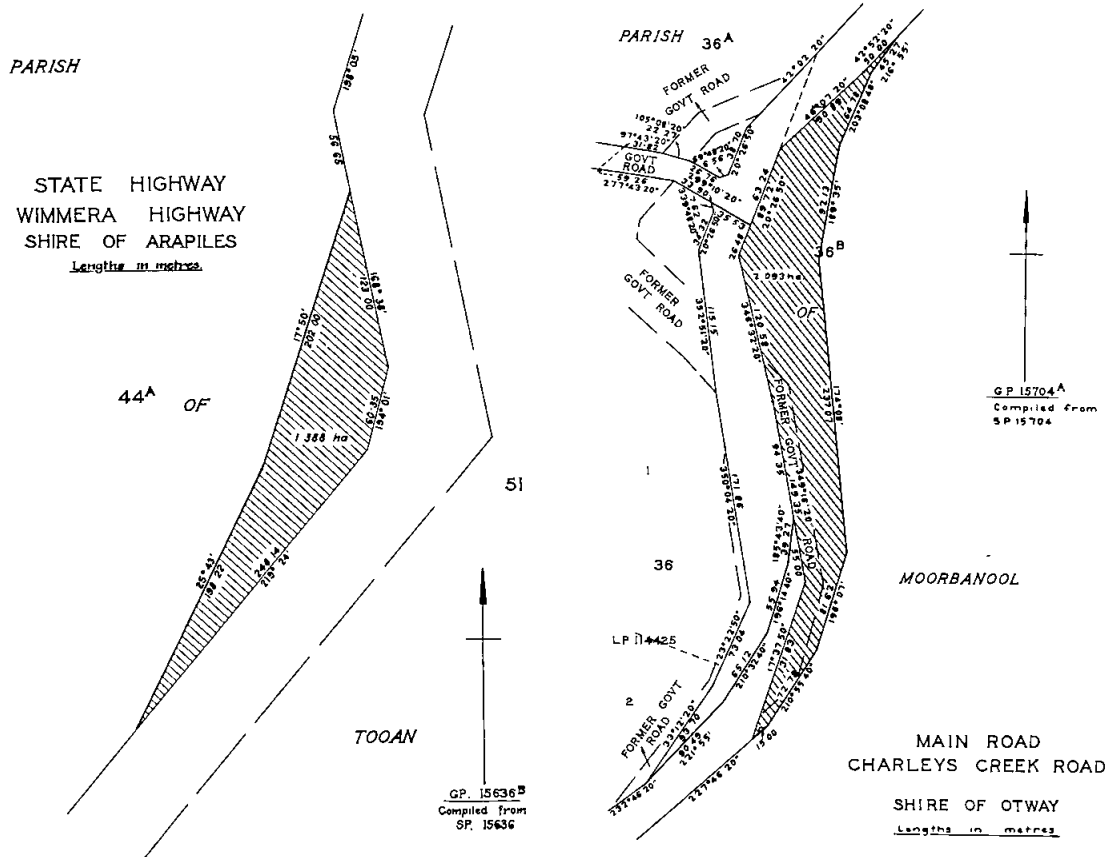

The land shown hatched on plans numbered G.P.15711A and G.P.15711B hereunder required for the Wild Dog Valley Road in the Shire of Woorayl.

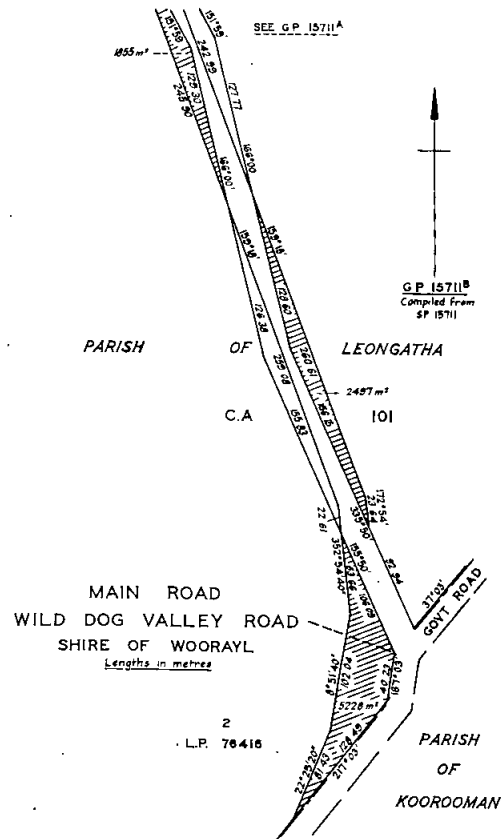
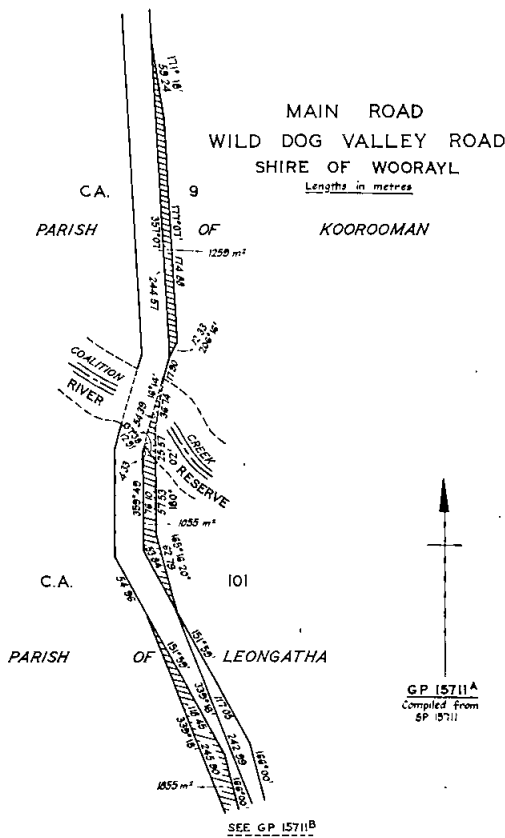

And the Honourable Steven Marshall Crabb, Her Majesty's Minister of Transport for the State of Victoria, shall give the necessary directions herein accordingly.

TOM FORRISTAL
Clerk of the Executive Council

COUNTRY ROADS ACT 1958

At the Executive Council Chamber, Melbourne, the twenty-eighth day of September, 1982

PRESENT:

- His Excellency the Governor of Victoria
Mr Crabb | Mr Simpson
Mr Wilkes

ORDER APPROVING OF LAND BEING ACQUIRED AND ROADS, DEVIATIONS OR WIDENINGS BEING MADE TOGETHER WITH ALL ANCILLARY WORKS REQUIRED TO BE EXECUTED IN CONJUNCTION THEREWITH

His Excellency the Governor of the State of Victoria, by and with the advice of the Executive Council thereof, being satisfied that there are funds legally available for acquiring the land, doth hereby approve the acquiring of the land described in the Schedule hereunder and the making of new roads and deviations from and widenings of existing roads, together with all ancillary works required to be executed in conjunction therewith, referred to in the said Schedule.

The land shown hatched on plan numbered G.P.15739 hereunder required for the Midland Highway in the Shire of Bannockburn.

SCHEDULE
Widenings of Existing Roads
The land shown hatched on plan numbered G.P.15745b hereunder required for Vincent Street in the City of Ararat.

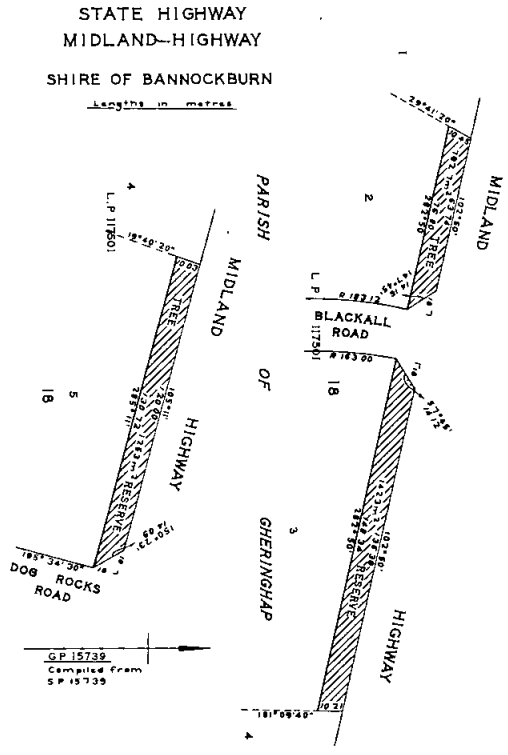
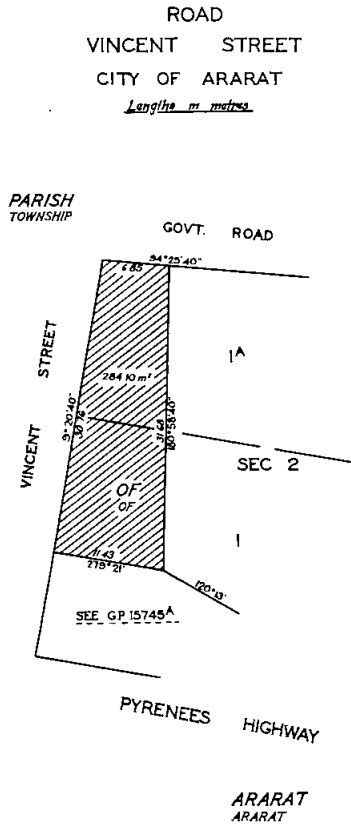

And the Honourable Steven Marshall Crabb, Her Majesty's Minister of Transport for the State of Victoria, shall give the necessary directions herein accordingly.

TOM FORRISTAL
Clerk of the Executive Council

CROWN LAND (RESERVES) ACT 1978

At the Executive Council Chamber, Melbourne, the twenty-eighth day of September, 1982

PRESENT:

- His Excellency the Governor of Victoria
- Mr Crabb | Mr Simpson
- Mr Wilkes

CROWN LANDS TEMPORARILY RESERVED
His Excellency the Governor of the State of Victoria, in the Commonwealth of Australia, by and with the advice of the Executive Council of the said State, pursuant to the provisions of sections 4 and 7 of the Crown Land (Reserves) Act 1978, and being of the opinion that the Crown lands concerned are required for the purposes respectively mentioned, doth hereby temporarily reserve

and also except from prospecting or from occupation for mining purposes under any miner's right, the Crown lands hereinafter described, viz.:

BUNINYONG—For Municipal Store-yard, 1.9 hectares, more or less, being Crown allotment 124G, Parish of Buninyong, as indicated by hatching on plan hereunder—(B.489⁽¹⁰⁾) (Rs.12145).

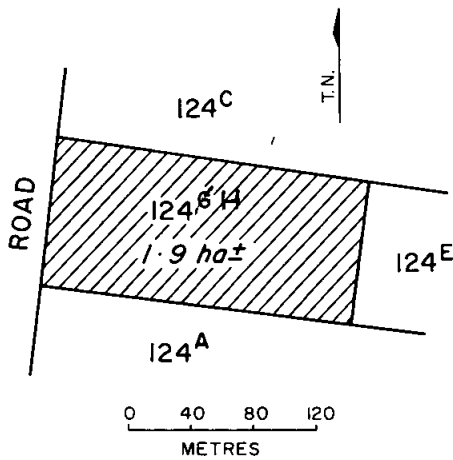

KARRABUMET—For Conservation of an Area of Natural Interest, 2.023 hectares, being Crown allotment 21G, Parish of Karrabumet, as indicated by hatching on plan hereunder—(K.119⁽⁴⁾) (Rs.6701).

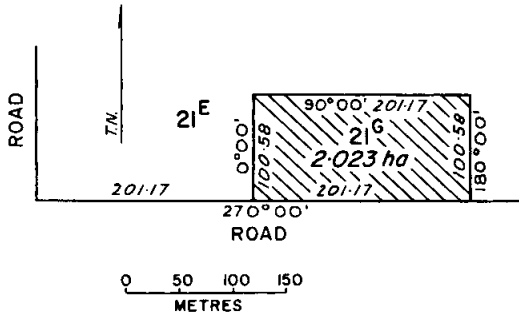

MIRBOO—For Water Supply, 5185 square metres, being Crown allotment 122G, Parish of Mirboo, as shown on Certified Plan No. 106044 lodged in the Central Plan Office—(M.517⁽¹⁶⁾) (Rs.12186).

SANDHURST (AT BENDIGO)—For Public Park, 263 square metres, being Crown allotment 16, section 34A, At Bendigo, Parish of Sandhurst, as indicated by hatching on plan hereunder—(S.372⁽¹²³⁾) (Rs.12184).

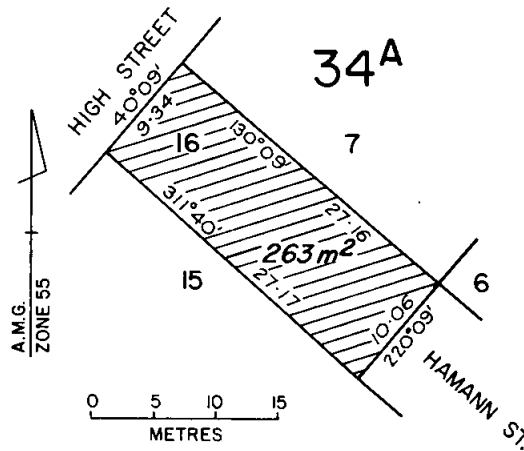

UPOTIPOTPON—For the Management of Wildlife, 21.24 hectares, being Crown allotment 18C, Parish of Upotipotpon, as indicated by hatching on plan hereunder—(U.53^(*)) (Rs.9112).

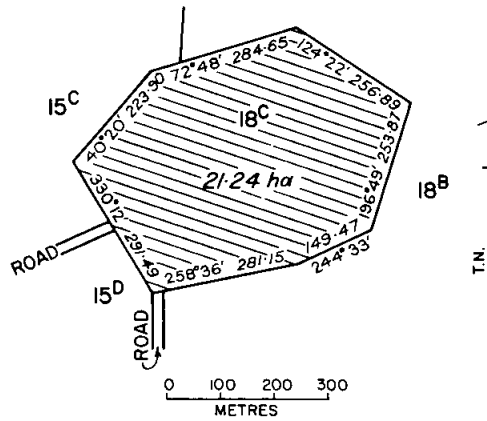

And the Honourable Roderick Alexander Mackenzie, Her Majesty's Minister of Lands for the State of Victoria, shall give the necessary directions herein accordingly.

TOM FORRISTAL
Clerk of the Executive Council

CROWN LAND (RESERVES) ACT 1978

At the Executive Council Chamber, Melbourne, the twenty-eighth day of September, 1982

PRESENT:

His Excellency the Governor of Victoria
Mr Crabb | Mr Simpson
Mr Wilkes

INCORPORATION OF COMMITTEE OF MANAGEMENT OF "WERRIBEE PARK"

His Excellency the Governor of the State of Victoria, in the Commonwealth of Australia, by and with the advice of the Executive Council of the said State, pursuant to

the provisions of section 14A (1) of the *Crown Land (Reserves) Act 1978*, and being satisfied that it is in the public interest to do so, doth by this notification declare that the committee of management, appointed under section 14 (2) of the said Act, of the Crown lands in the Parishes of Deutgam and Mambourin temporarily reserved for Public Recreation, Public Park, Gardens and Ornamental Plantations, Conservation of an Area of Historic Interest, Museums and Galleries, Educational Purposes, Conference Centre and the Promotion of Tourism by Order in Council of 21 July 1981 (see *Government Gazette* dated 22 July 1981), shall be a corporation and assign the name "Werribee Park Corporation" to the corporation, and pursuant to section 14B (3) of the said Act appoint Ronald J. Walker, C.B.E. as Chairman of the incorporated committee—(Rs.11425).

And the Honourable Roderick Alexander Mackenzie, Her Majesty's Minister of Lands for the State of Victoria, shall give the necessary directions herein accordingly.

TOM FORRISTAL
Clerk of the Executive Council

CROWN LAND (RESERVES) ACT 1978

At the Executive Council Chamber, Melbourne, the
twenty-eighth day of September, 1982

PRESENT:

His Excellency the Governor of Victoria	
Mr Crabb	Mr Simpson
Mr Wilkes	

CROWN LAND PLACED UNDER THE CONTROL AND MANAGEMENT OF THE STATE RIVERS AND WATER SUPPLY COMMISSION

His Excellency the Governor of the State of Victoria, in the Commonwealth of Australia, by and with the advice of the Executive Council of the said State, pursuant to the provisions of section 18 (1) of the *Crown Land (Reserves) Act 1978*, doth hereby place under the control and management of the State Rivers and Water Supply Commission, the Crown land hereinafter described, viz.:

KURDGWEECHEE—The land being Crown allotment 46B, Parish of Kurdgweechee, temporarily reserved for Water Supply by Order in Council of 18 August 1981 (see *Government Gazette* dated 26 August 1981)—(Rs.11460).

And the Honourable Roderick Alexander Mackenzie, Her Majesty's Minister of Lands for the State of Victoria, shall give the necessary directions herein accordingly.

TOM FORRISTAL
Clerk of the Executive Council

CROWN LAND (RESERVES) ACT 1978

At the Executive Council Chamber, Melbourne, the
twenty-eighth day of September, 1982

PRESENT:

His Excellency the Governor of Victoria	
Mr Crabb	Mr Simpson
Mr Wilkes	

CROWN LAND PLACED UNDER THE CONTROL AND MANAGEMENT OF THE STATE RIVERS AND WATER SUPPLY COMMISSION

His Excellency the Governor of the State of Victoria, in the Commonwealth of Australia, by and with the advice of the Executive Council of the said State, pursuant to the provisions of section 18 (1) of the *Crown Land (Reserves) Act 1978*, doth hereby place under the control and management of the State Rivers and Water Supply Commission, the Crown land hereinafter described, viz.:

YATPOOL—The land being Crown allotment 62A, Parish of Yatpool, temporarily reserved for Water Supply by Order in Council of 8 June 1982 (see *Government Gazette* dated 16 June 1982)—(Rs.11679).

And the Honourable Roderick Alexander Mackenzie, Her Majesty's Minister of Lands for the State of Victoria, shall give the necessary directions herein accordingly.

TOM FORRISTAL
Clerk of the Executive Council

CROWN LAND (RESERVES) ACT 1978

At the Executive Council Chamber, Melbourne, the
twenty-eighth day of September, 1982

PRESENT:

His Excellency the Governor of Victoria	
Mr Crabb	Mr Simpson
Mr Wilkes	

CROWN LAND PLACED UNDER THE CONTROL AND MANAGEMENT OF THE STATE RIVERS AND WATER SUPPLY COMMISSION

His Excellency the Governor of the State of Victoria, in the Commonwealth of Australia, by and with the advice of the Executive Council of the said State, pursuant to the provisions of section 18 (1) of the *Crown Land (Reserves) Act 1978*, doth hereby place under the control and management of the State Rivers and Water Supply Commission, the Crown land hereinafter described, viz.:

KALPIENUNG—The land being Crown allotment 80B, Parish of Kalpienung, temporarily reserved for Water Supply by Order in Council of 16 June 1982 (see *Government Gazette* dated 23 June 1982)—(Rs.12111).

And the Honourable Roderick Alexander Mackenzie, Her Majesty's Minister of Lands for the State of Victoria, shall give the necessary directions herein accordingly.

TOM FORRISTAL
Clerk of the Executive Council

CROWN LAND (RESERVES) ACT 1978

At the Executive Council Chamber, Melbourne, the
twenty-eighth day of September, 1982

PRESENT:

His Excellency the Governor of Victoria	
Mr Crabb	Mr Simpson
Mr Wilkes	

REVOCATION OF TEMPORARY RESERVATIONS OF LANDS BY ORDERS IN COUNCIL

His Excellency the Governor of the State of Victoria, in the Commonwealth of Australia, by and with the advice of the Executive Council of the said State, pursuant to the provisions of section 10 of the *Crown Land (Reserves) Act 1978*, doth hereby revoke the temporary reservations of lands by Orders in Council hereinafter described, viz.:

BETHANGA—The temporary reservation as a site for Public Recreation and the withholding from sale, leasing and licensing by Order in Council of 22 May 1882 of 9.308 hectares, more or less, of land in the Township of Bethanga (in section G)—(B.691⁽³⁾) (Rs.4010).

BETHANGA—The temporary reservation by Order in Council of 11 April 1932 of 2.074 hectares, more or less, of land in the Township of Bethanga (in section G) as a site for Public Recreation—(B.691⁽³⁾) (Rs.4010).

BETHANGA—The temporary reservation by Order in Council of 3 May 1932 of 7082 square metres, more or less, of land in the Township of Bethanga (in section G) as a site for Public Recreation—(B.691⁽³⁾) (Rs.4010).

WEHLA—The temporary reservation as a site for Public purposes (State School) and the withholding from sale, leasing and licensing by Order in Council of 15 April 1878 of 2.023 hectares of land in the Parish of Wehla (adjoining allotment 35)—(Rs.11605).

WURDI YOUANG—The temporary reservation as a site for Public purposes (State School) and the withholding from sale, leasing and licensing by Order in Council of 1 April 1879 of 2.020 hectares of land in the Parish of Wurdj Youang (in section A)—(Rs.7048).

CUT-PAW-PAW (MARIBYRNONG)—The temporary reservation by Order in Council of 22 November 1966 of 1.373 hectares of land in the Parish of Cut-paw-paw as a site for Public Purposes (Government Buildings), so far only as the portions thereof containing 1586 square metres, as defined by description and hatching on plan published in the *Government Gazette* dated 8 September 1982, are concerned—(C.345⁽¹⁶⁾) (Rs.8738).

MARYBOROUGH—The temporary reservation by Order in Council of 6 December 1949 of 2529 square metres, more or less, of land in the Parish of Maryborough as a site for Drainage purposes, so far only as the portion thereof containing 1000 square metres, more or less, as defined by description and hatching on plan published in the *Government Gazette* dated 8 September 1982, is concerned—(M.66⁽¹⁵⁾) (Rs.6471).

PROOINGA—The temporary reservation by Order in Council of 27 March 1917 of 1.882 hectares of land in the Parish of Prooinga as a site for a State School, revoked as to part by Order of 10 August 1965, so far as the balance thereof containing 1.806 hectares, is concerned—(Rs.1442).

STAWELL—The temporary reservation as a site for Racing and General Recreation and the withholding from sale, leasing and licensing by Order in Council of 20 November 1876 of 36.92 hectares of land in the Township of Stawell (called Municipal District of Stawell in Order), revoked as to part by Order of 8 November 1955, so far only as the portion thereof containing 4645 square metres, as defined by description and hatching on plan published in the *Government Gazette* dated 8 September 1982, is concerned—(S.329⁽¹³⁾) (Rs.3938).

And the Honourable Roderick Alexander Mackenzie, Her Majesty's Minister of Lands for the State of Victoria, shall give the necessary directions herein accordingly.

TOM FORRISTAL
Clerk of the Executive Council

CROWN LAND (RESERVES) ACT 1978

At the Executive Council Chamber, Melbourne, the twenty-eighth day of September, 1982

PRESENT:

His Excellency the Governor of Victoria
Mr Crabb | Mr Simpson
Mr Wilkes

CROWN RESERVE VESTED IN THE CORPORATION OF THE CITY OF ECHUCA

His Excellency the Governor of the State of Victoria, in the Commonwealth of Australia, by and with the advice of the Executive Council of the said State, pursuant to section 16 (1) of the *Crown Land (Reserves) Act 1978*, doth hereby direct that the Crown land described in the Schedule hereunder be vested in the Corporation of the City of Echuca on trust for the purposes for which the land has been reserved, and, pursuant to section 16 (2) of the said Act, doth also empower the said municipality to grant leases or licences for a term not exceeding 21 years in respect of the land for the purposes of the reservation.

SCHEDULE

Township of Echuca, Parish of Echuca North, being Crown land containing 5944 square metres temporarily reserved as a site for Swimming Pool purposes by Order in Council of 30 April 1957 published in the *Government Gazette* dated 8 May 1957 (page 1496)—(Rs.7548).

And the Honourable Roderick Alexander Mackenzie, Her Majesty's Minister of Lands for the State of Victoria, shall give the necessary directions herein accordingly.

TOM FORRISTAL
Clerk of the Executive Council

LOCAL GOVERNMENT ACT 1958

At the Executive Council Chamber, Melbourne, the twenty-eighth day of September, 1982

PRESENT:

His Excellency the Governor of Victoria
Mr Crabb | Mr Simpson
Mr Wilkes

ROAD DISCONTINUED—CITY OF MELBOURNE

Whereas it is provided in section 528 (2) of the *Local Government Act 1958*, that where a road (whether or not a public highway but not being a road set out on land of the Crown) or any part thereof is not required for public

use, the Governor in Council on the request of the council of the municipality in which such road is situated made not less than one month after publishing in a newspaper generally circulating in the district and posting to the registered proprietor (if any) of the land and the owners and occupiers (if any) of lands abutting or immediately adjacent to the road notice of intention to make such a request may by Order published in the *Government Gazette* direct that such road or part shall be discontinued and thereupon such road or part shall be discontinued accordingly.

And whereas the Council of the City of Melbourne has requested that the Governor in Council direct that part of a road off Mawby Lane, North Melbourne be discontinued and not less than one month previously has published in a newspaper generally circulating in the district and posted to the registered proprietor of the land in the road and to the owners and occupiers of lands abutting or immediately adjacent to the road notice of intention to make such a request.

Now therefore, His Excellency the Governor of the State of Victoria, by and with the advice of the Executive Council thereof, hereby directs that the said part of a road which is shown by hatching on the plan hereunder, shall be discontinued and the land in the said part of a road may be sold by the Council of the City of Melbourne by agreement.

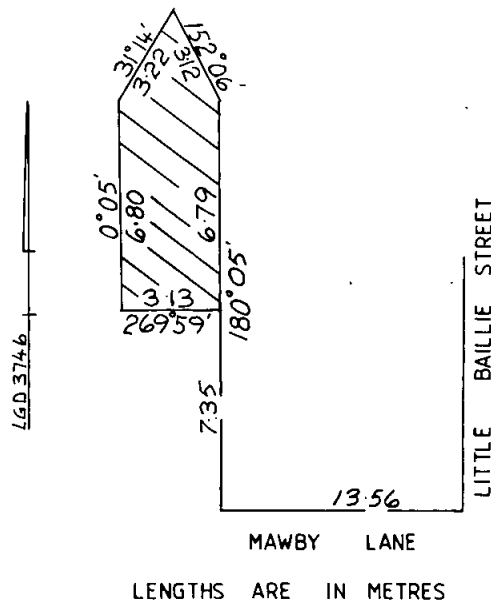

And the Honourable Frank Noel Wilkes, Her Majesty's Minister for Local Government for the State of Victoria, shall give the necessary directions herein accordingly.

TOM FORRISTAL
Clerk of the Executive Council

LOCAL GOVERNMENT ACT 1958

At the Executive Council Chamber, Melbourne, the twenty-eighth day of September, 1982

PRESENT:

His Excellency the Governor of Victoria
Mr Crabb | Mr Simpson
Mr Wilkes

ROAD DISCONTINUED—CITY OF KEW

Whereas it is provided in section 528 (2) of the Local Government Act 1958, that where a road (whether or not a public highway but not being a road set out on land of the Crown) or any part thereof is not required for public use, the Governor in Council on the request of the council of the municipality in which such road is situated made not less than one month after publishing in a newspaper generally circulating in the district and posting to the registered proprietor (if any) of the land and the owners and occupiers (if any) of lands abutting or immediately adjacent to the road notice of intention to make such a request may by Order published in the *Government Gazette* direct that such road or part shall be discontinued and thereupon such road or part shall be discontinued accordingly.

And whereas the Council of the City of Kew has requested that the Governor in Council direct that part of Rockingham Street, Kew be discontinued and not less than one month previously has published in a newspaper generally circulating in the district and posted to the registered proprietor of the land in the road and to the owners and occupiers of lands abutting or immediately adjacent to the road notice of intention to make such a request.

Now therefore, His Excellency the Governor of the State of Victoria, by and with the advice of the Executive Council thereof, hereby directs—

- (a) that the said part of a road which is shown by hatching and cross-hatching on the plan hereunder shall be discontinued;

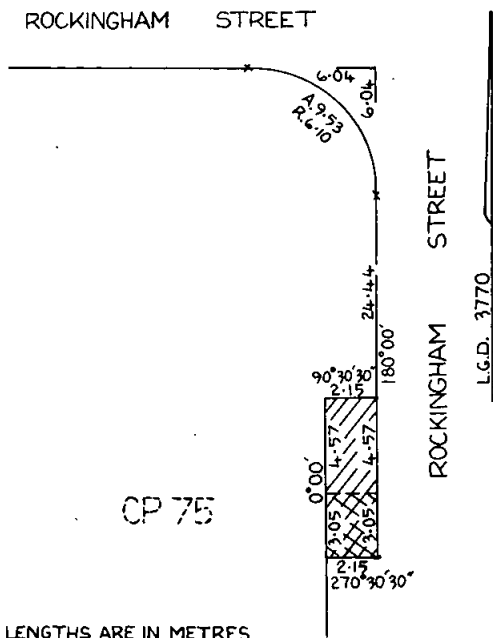

LENGTHS ARE IN METRES

- (b) that notwithstanding such discontinuance the Melbourne and Metropolitan Board of Works shall continue to have and possess the same right title power authority or interest in or in

relation to the whole of the land shown by cross-hatching on the said plan as it had or possessed prior to such discontinuance with respect to or in connection with any drains or pipes laid or erected in on or over such land for the purposes of drainage or sewerage;

- (c) that, subject to any such right title power authority or interest the land in the said part of a road may be sold by the Council of the City of Kew by agreement.

And the Honourable Frank Noel Wilkes, Her Majesty's Minister for Local Government for the State of Victoria, shall give the necessary directions herein accordingly.

TOM FORRISTAL
Clerk of the Executive Council

LOCAL GOVERNMENT ACT 1958

At the Executive Council Chamber, Melbourne, the twenty-eighth day of September, 1982

PRESENT:

His Excellency the Governor of Victoria
Mr Crabb | Mr Simpson
Mr Wilkes

ROAD DISCONTINUED—CITY OF FOOTSCRAY

Whereas it is provided in section 528 (2) of the Local Government Act 1958, that where a road (whether or not a public highway but not being a road set out on land of the Crown) or any part thereof is not required for public use, the Governor in Council on the request of the council of the municipality in which such road is situated made not less than one month after publishing in a newspaper generally circulating in the district and posting to the registered proprietor (if any) of the land and the owners and occupiers (if any) of lands abutting or immediately adjacent to the road notice of intention to make such a request may by Order published in the *Government Gazette* direct that such road or part shall be discontinued and thereupon such road or part shall be discontinued accordingly.

And whereas the Council of the City of Footscray has requested that the Governor in Council direct that a road off Little David Street, Yarraville, be discontinued and not less than one month previously has published in a newspaper generally circulating in the district and posted to the registered proprietor of the land in the road and to the owners and occupiers of lands abutting or immediately adjacent to the road notice of intention to make such a request.

Now therefore, His Excellency the Governor of the State of Victoria, by and with the advice of the Executive Council thereof, hereby directs—

- (a) that the said road which is shown by hatching, cross-hatching and cross-hatching marked A on the plan hereunder shall be discontinued;

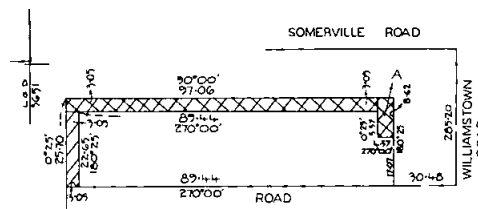

LENGTHS ARE IN METRES

- (b) that notwithstanding such discontinuance the Melbourne and Metropolitan Board of Works shall continue to have and possess the same right title power authority or interest in or in

relation to the whole of the land shown by cross-hatching and cross-hatching marked A on the said plan as it had or possessed prior to such discontinuance with respect to or in connection with any drains or pipes laid or erected in on or over such land for the purposes of drainage or sewerage;

- (c) that, subject to any such right title power authority or interest the land in the said road shown by cross-hatching marked A on the said plan may be sold by the Council of the City of Footscray by agreement and the land in the said road shown by hatching and cross-hatching on the said plan shall be retained by the said Council for municipal purposes.

And the Honourable Frank Noel Wilkes, Her Majesty's Minister for Local Government for the State of Victoria, shall give the necessary directions herein accordingly.

TOM FORRISTAL
Clerk of the Executive Council

LIQUOR CONTROL ACT 1968

At the Executive Council Chamber, Melbourne, the twenty-eighth day of September, 1982

PRESENT:

His Excellency the Governor of Victoria	
Mr Crabb	Mr Simpson
Mr Wilkes	

APPOINTMENT OF A MEMBER OF THE LIQUOR CONTROL COMMISSION

In pursuance of the provisions of section 6 of the *Liquor Control Act 1968*, His Excellency the Governor of the State of Victoria, by and with the advice of the Executive Council thereof, doth hereby appoint—

ELIZABETH JUNE BOND, B.A.,
as a Member of the Liquor Control Commission during the period from 25 October 1982 to 31 December 1982, both dates inclusive.

And the Honourable William Albert Landeryou, Her Majesty's Minister for Tourism for the State of Victoria, shall give the necessary directions herein accordingly.

TOM FORRISTAL
Clerk of the Executive Council

WATER ACT 1958

At the Executive Council Chamber, Melbourne, the twenty-eighth day of September, 1982

PRESENT:

His Excellency the Governor of Victoria	
Mr Crabb	Mr Simpson
Mr Wilkes	

APPOINTMENT OF ACTING COMMISSIONER OF THE STATE RIVERS AND WATER SUPPLY COMMISSION

Pursuant to the provisions of the *Water Act 1958* His Excellency the Governor of the State of Victoria by and with the advice of the Executive Council thereof doth by this Order appoint Roy BIRD to be an Acting Commissioner of the State Rivers and Water Supply Commission under the *Water Act 1958* as from 1 October 1982 to 31 March 1983 inclusive, during the period following the retirement of the Chairman of the said State Rivers and Water Supply Commission, Mr William Edward Bromfield or until appointment of a successor, whichever occurs first.

And the Honourable David Ronald White, Her Majesty's Minister of Water Supply for the State of Victoria, shall give the necessary directions herein accordingly.

TOM FORRISTAL
Clerk of the Executive Council

COLAC WATERWORKS TRUST

At the Executive Council Chamber, Melbourne, the twenty-eighth day of September, 1982

PRESENT:

His Excellency the Governor of Victoria	
Mr Crabb	Mr Simpson
Mr Wilkes	

EXTENT OF COLAC RURAL DISTRICT INCREASED

Under the powers conferred by the *Water Act* and all other powers enabling him in that behalf, His Excellency the Governor of the State of Victoria, by and with the advice of the Executive Council of the said State, doth hereby declare, order and direct that the extent of the Colac Rural District of the Colac Waterworks Trust be increased by adding to the Districts the areas coloured yellow on a plan approved by the Governor in Council and deposited in the office of the State Rivers and Water Supply Commission, Melbourne (Corr. No. 80/3937/69) and as on and from the date hereof the extent of such District shall be and be deemed to be increased accordingly.

And the Honourable David Ronald White, Her Majesty's Minister of Water Supply for the State of Victoria, shall give the necessary directions herein accordingly.

TOM FORRISTAL
Clerk of the Executive Council

HEYFIELD WATERWORKS TRUST

At the Executive Council Chamber, Melbourne, the twenty-eighth day of September, 1982

PRESENT:

His Excellency the Governor of Victoria	
Mr Crabb	Mr Simpson
Mr Wilkes	

GLENMAGGIE-COONGULA URBAN DISTRICT—SITES OF PUMP, PUMPING STATION, STORAGES AND PIPELINES APPROVED—SITES OF SERVICE BASIN, PUMPS AND PIPELINES EXPUNGED

Under the powers conferred by the *Water Act* and all other powers enabling him in that behalf, His Excellency the Governor of the State of Victoria, by and with the advice of the Executive Council of the said State, doth hereby—

- (a) approve of the sites required by the Heyfield Waterworks Trust for a pump, pumping station, storage tank, service basin and additional pipelines as shown by blue, purple, pink, orange and yellow colours respectively on the said plan; and
- (b) expunge the sites previously approved for the Heyfield Waterworks Trust for a service basin, pumps and pipelines as shown by green and brown colours on the said plan, the said plan being approved by the Governor in Council by and with this Order and deposited in the Office of the State Rivers and Water Supply Commission, Melbourne (Corr. No. 74/719/56).

And the Honourable David Ronald White, Her Majesty's Minister of Water Supply for the State of Victoria, shall give the necessary directions herein accordingly.

TOM FORRISTAL
Clerk of the Executive Council

LISMORE AND DERRINALLUM WATERWORKS TRUST

At the Executive Council Chamber, Melbourne, the
twenty-eighth day of September, 1982

PRESENT:

His Excellency the Governor of Victoria	
Mr Crabb	Mr Simpson
Mr Wilkes	

EXTENT OF LISMORE AND DERRINALLUM RURAL DISTRICT INCREASED

Under the powers conferred by the Water Act and all other powers enabling him in that behalf, His Excellency the Governor of the State of Victoria, by and with the advice of the Executive Council of the said State, doth hereby declare, order and direct that the extent of the Rural District of the Lismore and Derrinallum Waterworks Trust be increased by adding the two areas shown by red border on a plan approved by the Governor in Council, by and with this Order and deposited in the office of the State Rivers and Water Supply Commission, Melbourne (Corr. No. 81/2623/19) and as on and from the date hereof the extent of such District, shall be and be deemed to be increased accordingly.

And the Honourable David Ronald White, Her Majesty's Minister of Water Supply for the State of Victoria, shall give the necessary directions herein accordingly.

TOM FORRISTAL
Clerk of the Executive Council

ARARAT SEWERAGE AUTHORITY

At the Executive Council Chamber, Melbourne, the
twenty-eighth day of September, 1982

PRESENT:

His Excellency the Governor of Victoria	
Mr Crabb	Mr Simpson
Mr Wilkes	

EXTENT OF ARARAT SEWERAGE DISTRICT INCREASED

Under the powers conferred by the Sewerage Districts Act and all other powers enabling him in that behalf, His Excellency the Governor of the State of Victoria, by and with the advice of the Executive Council of the said State, doth hereby declare, order and direct that the extent of the Sewerage District of the Ararat Sewerage Authority be increased by adding thereto the lands shown by red border on the plan approved by the Governor in Council, by and with this Order and deposited in the Office of the State Rivers and Water Supply Commission, Melbourne (Corr. No. 74/1217/56) and as on and from the date hereof the extent of such district shall be and be deemed to be increased accordingly.

And the Honourable David Ronald White, Her Majesty's Minister of Water Supply for the State of Victoria, shall give the necessary directions herein accordingly.

TOM FORRISTAL
Clerk of the Executive Council

RACING ACT 1958

At the Executive Council Chamber, Melbourne, the
twenty-eighth day of September, 1982

PRESENT:

His Excellency the Governor of Victoria	
Mr Crabb	Mr Simpson
Mr Wilkes	

In pursuance of the powers conferred by section 85 of the Racing Act 1958, His Excellency the Governor of the State of Victoria, by and with the advice of the Executive Council of the said State, doth by this Order appoint

LAURENCE FRANCIS SHEEHAN being a person nominated by the Victorian Bookmakers' Association Limited to be a Member of the Bookmakers and Bookmakers' Clerks Registration Committee for the period 5 September 1982 to 4 September 1985.

And the Honourable Neil Trezise, Her Majesty's Minister for Youth, Sport and Recreation for the State of Victoria, shall give the necessary directions herein accordingly.

TOM FORRISTAL
Clerk of the Executive Council

SOIL CONSERVATION AND LAND UTILIZATION ACT 1958

At the Executive Council Chamber, Melbourne, the
twenty-eighth day of September, 1982

PRESENT:

His Excellency the Governor of Victoria	
Mr Crabb	Mr Simpson
Mr Wilkes	

Whereas in pursuance of the powers conferred by section 15 of the Soil Conservation and Land Utilization Act 1958 an Order reconstituting and partially subdividing the Alpine Soil Conservation District was approved by His Excellency the Governor in Council on 7 September 1982.

Now therefore His Excellency the Governor of Victoria upon the recommendation of the Soil Conservation Authority and with the advice of the Executive Council of the said State completes the subdivision of the Alpine Soil Conservation District by adding the following Subdivision:

Subdivision No. 3—Comprising Mount Hotham Alpine Resort, Mount Buller Alpine Resort and Falls Creek Tourist Area.

And the Honourable Evan Walker, Her Majesty's Minister for Conservation for the State of Victoria, shall give the necessary directions herein accordingly.

TOM FORRISTAL
Clerk of the Executive Council

SOIL CONSERVATION AND LAND UTILIZATION ACT 1958

At the Executive Council Chamber, Melbourne, the
twenty-eighth day of September, 1982

PRESENT:

His Excellency the Governor of Victoria	
Mr Crabb	Mr Simpson
Mr Wilkes	

DISTRICT ADVISORY COMMITTEE

NORTHERN MALLEE SOIL CONSERVATION DISTRICT

Whereas a vacancy exists on the Northern Mallee Soil Conservation District Advisory Committee due to the transfer of Graeme Bruce Campbell, being the person appointed to represent the Department of Agriculture, now, therefore, I, the Governor of the State of Victoria, by and with the advice of the Executive Council thereof, and in pursuance of the provisions of section 15 of the Soil Conservation and Land Utilization Act, doth hereby remove the said Graeme Bruce Campbell from office and appoint the following person to such a vacancy for a period up to and including 28 October 1983.

GEOFFREY THOMAS STRATFORD, being the person appointed to represent the Department of Agriculture.

And the Honourable Evan Walker, Her Majesty's Minister for Conservation for the State of Victoria, shall give the necessary directions herein accordingly.

TOM FORRISTAL
Clerk of the Executive Council

This Order is in lieu of the Order in Council which was approved on 20 July 1982.

MELBOURNE AND METROPOLITAN TRAMWAYS
ACT 1958, No. 6311

At the Executive Council Chamber, Melbourne, the
twenty-eighth day of September, 1982

PRESENT:

His Excellency the Governor of Victoria	
Mr Crabb	Mr Simpson
Mr Wilkes	

Whereas His Excellency the Governor of the State of Victoria by and with the advice of the Executive Council thereof has this day consented pursuant to the provisions of section 28 of the *Melbourne and Metropolitan Tramways Act 1958*, to the Melbourne and Metropolitan Tramways Board raising by way of a loan an amount not exceeding One hundred and fourteen thousand six hundred dollars (\$114 600); and whereas His Excellency the Governor is satisfied that a sufficient proportion of the loan to be so raised will fall due and be repaid in each year during the currency of the proposed loan; now therefore it is directed pursuant to the provisions of section 28 (6) of the said Act, that it shall not be necessary to provide a sinking fund in connection with such loan.

And the Honourable Robert Allen Jolly, Her Majesty's Treasurer for the State of Victoria, shall give the necessary directions herein accordingly.

TOM FORRISTAL
Clerk of the Executive Council

RAILWAY CONSTRUCTION AND PROPERTY BOARD
ACT 1979, No. 9345

At the Executive Council Chamber, Melbourne, the
twenty-eighth day of September, 1982

PRESENT:

His Excellency the Governor of Victoria	
Mr Crabb	Mr Simpson
Mr Wilkes	

Whereas His Excellency the Governor of the State of Victoria by and with the advice of the Executive Council thereof has this day consented pursuant to the provisions of the *Railway Construction and Property Board Act 1979* to the Railway Construction and Property Board raising by way of a loan the sum of One million dollars (\$1 000 000); and whereas His Excellency the Governor in Council is satisfied that a sufficient proportion of the loan to be raised will fall due and be repaid in each year during the currency of the proposed loan; now therefore it is directed pursuant to the provisions of section 37 (3) of the said Act, that it shall not be necessary to provide a sinking fund in connection with such loan.

And the Honourable Robert Allen Jolly, Her Majesty's Treasurer for the State of Victoria, shall give the necessary directions herein accordingly.

TOM FORRISTAL
Clerk of the Executive Council

SUPERANNUATION ACT 1958

At the Executive Council Chamber, Melbourne, the
twenty-eighth day of September, 1982

PRESENT:

His Excellency the Governor of Victoria	
Mr Crabb	Mr Simpson
Mr Wilkes	

Pursuant to the powers conferred by the provisions of paragraph (ja) of sub-section (1) of section 3 of the *Superannuation Act 1958*, His Excellency the Governor of the State of Victoria, by and with the advice of the Executive Council thereof doth by this Order declare that the provisions of the *Superannuation Act* shall apply to the officers named in the Schedule set out hereunder.

SCHEDULE

CANNING, RAYMOND DOUGLAS, and
MCAULEY, MICHAEL JAMES NOBLET,
Chisholm Institute of Technology.
POLLOCK, EDWARD JOHN,
Police Reservist.
BUSHELL, KATRINA MARGARET,
RAE, VICKI ANN, and
THOMAS, HENRY MARTIN,
Warrnambool Institute of Advanced Education.

And the Honourable Robert Allen Jolly, Her Majesty's Treasurer for the State of Victoria, shall give the necessary directions herein accordingly.

TOM FORRISTAL
Clerk of the Executive Council

PUBLIC SERVICE ACT 1974

At the Executive Council Chamber, Melbourne, the
sixth day of October, 1982

PRESENT:

His Excellency the Governor of Victoria	
Mr Landeryou	Mr Spyker
Mr Roper	Mr Tresize

AMENDMENT TO SCHEDULE TWO TO PUBLIC
SERVICE ACT 1974

Pursuant to the powers conferred in sections 21 and 22 of the *Public Service Act 1974*, His Excellency the Governor in Council by and with the advice of the Executive Council doth by this Order—

- (i) Abolish the Ministry for Tourism and the office of Director of Tourism by deleting from Part B of the Second Schedule to the said Act the item: "Ministry for Tourism—Director of Tourism".
- (ii) Create the Ministry for Tourism and the office of Director of Tourism by adding at the end of Part A to the said Schedule the item "Ministry for Tourism—Director of Tourism".

And the Honourable John Cain, Her Majesty's Premier for the State of Victoria, shall give the necessary directions herein accordingly.

L. G. HOUSTON
Acting Clerk of the Executive Council

COMMUNITY WELFARE SERVICES ACT 1970

At the Executive Council Chamber, Melbourne, the
sixth day of October, 1982

PRESENT:

His Excellency the Governor of Victoria	
Mr Landeryou	Mr Spyker
Mr Roper	Mr Tresize

ESTABLISHMENT OF A CHILDRENS HOME

In the pursuance of the powers conferred upon him by section 27 of the *Community Welfare Services Act 1970* and all other powers him thereunto enabling, His Excellency the Governor of the State of Victoria in the Commonwealth of Australia, by and with the advice of the Executive Council of the said State, doth by this notice establish; the building situated at 86 Maribyrnong Road, Ascot Vale (to be known as the Western Suburbs Transition Care Unit) to be a Childrens Home as on and from 6 October 1982 for the care and welfare of children or young persons admitted to the care of Department of Community Welfare Services.

And the Honourable Pauline Therese Toner, Her Majesty's Minister for Community Welfare Services for the State of Victoria, shall give the necessary directions herein accordingly.

L. G. HOUSTON
Acting Clerk of the Executive Council

Country Roads Act 1958

ORDER APPROVING OF LAND BEING ACQUIRED AND ROADS, DEVIATIONS OR WIDENINGS BEING MADE TOGETHER WITH ALL ANCILLARY WORKS REQUIRED TO BE EXECUTED IN CONJUNCTION THEREWITH

At the Executive Council Chamber, Melbourne, the sixth day of October, 1982

PRESENT:

His Excellency the Governor of Victoria
Mr Landeryou | Mr Spyker
Mr Roper | Mr Tresize

His Excellency the Governor of the State of Victoria, by and with the advice of the Executive Council thereof, being satisfied that there are funds legally available for acquiring the land, doth hereby approve the acquiring of the land described in the schedule hereunder and the making of new roads and deviations from and widenings of existing roads, together with all ancillary works required to be executed in conjunction therewith, referred to in the said schedule.

SCHEDULE

Making of New Roads

The land shown hatched on plans numbered G.P.15662b, G.P.15663b, G.P.15667b, G.P.15669b and G.P.15676c hereunder required for the new roads in the Shire of Benalla.

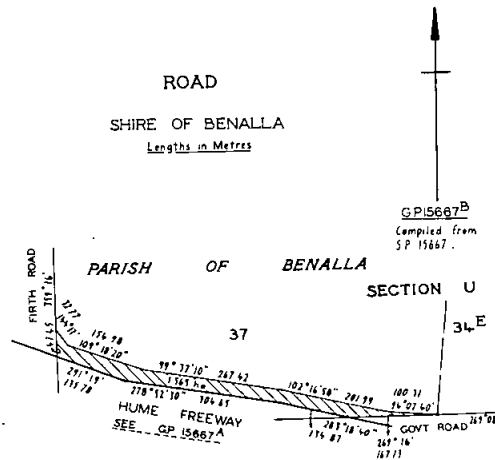
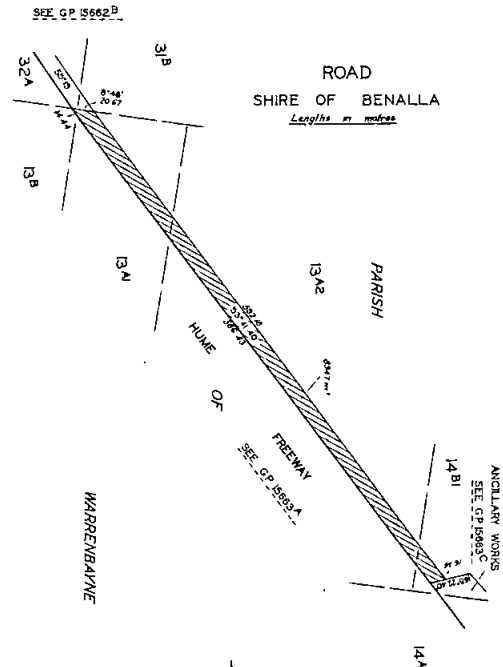
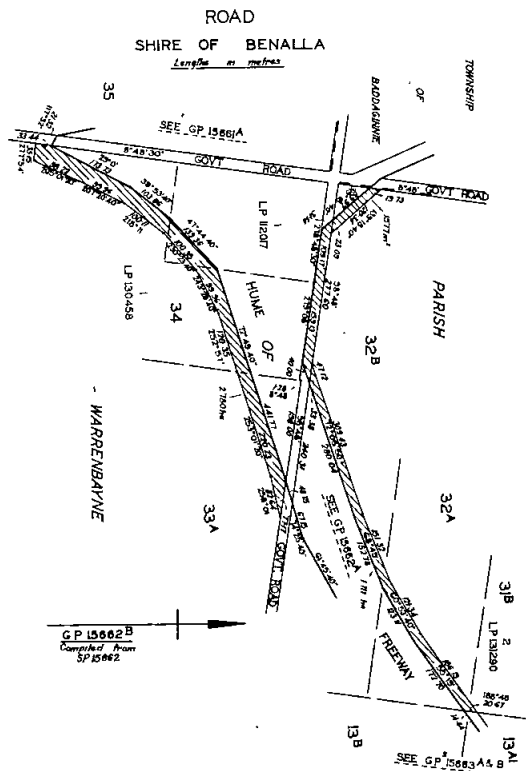

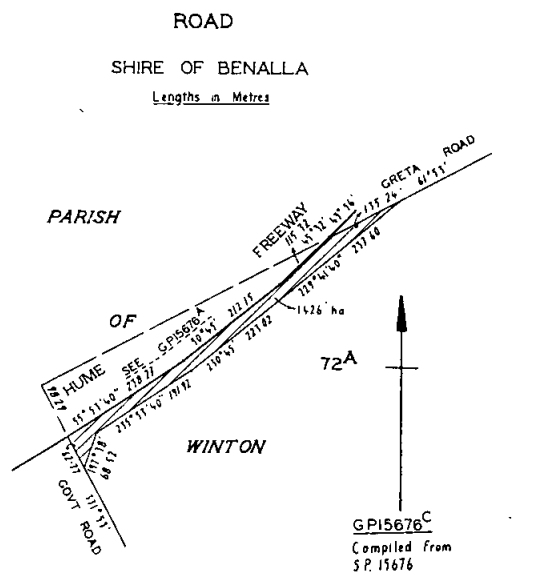
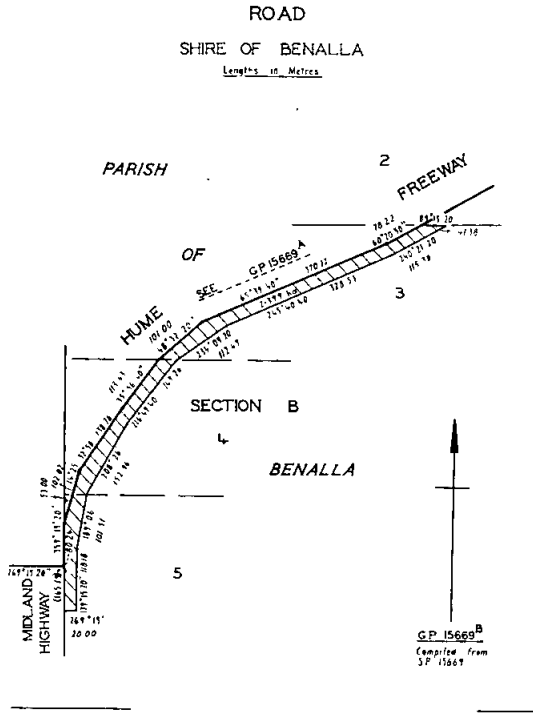

The land shown hatched on plans numbered G.P.15660, G.P.15661A, G.P.15662A, G.P.15663A, G.P.15664, G.P.15665, G.P.15666A, G.P.15667A, G.P.15668A, G.P.15668B, G.P.15669A, G.P.15670, G.P.15671A, G.P.15672, G.P.15673A, G.P.15674, G.P.15675, G.P.15676A and G.P.15676B hereunder required for the Hume Freeway in the Shires of Violet Town and Benalla.

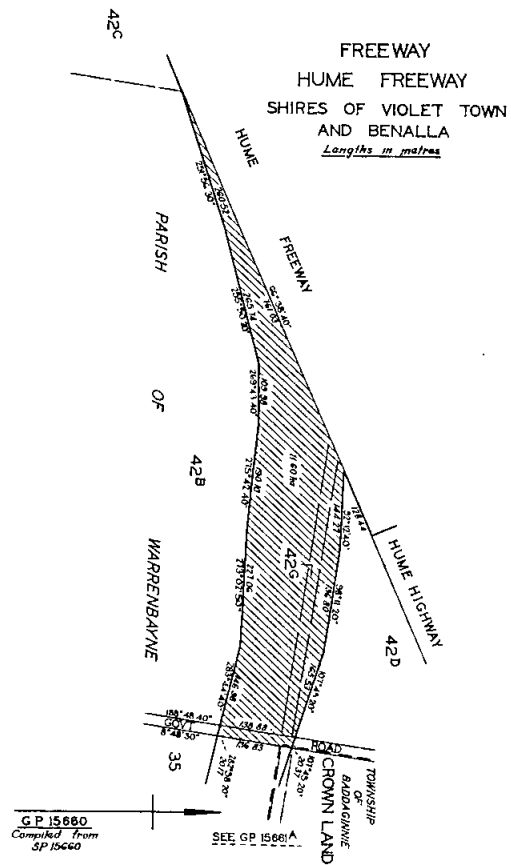

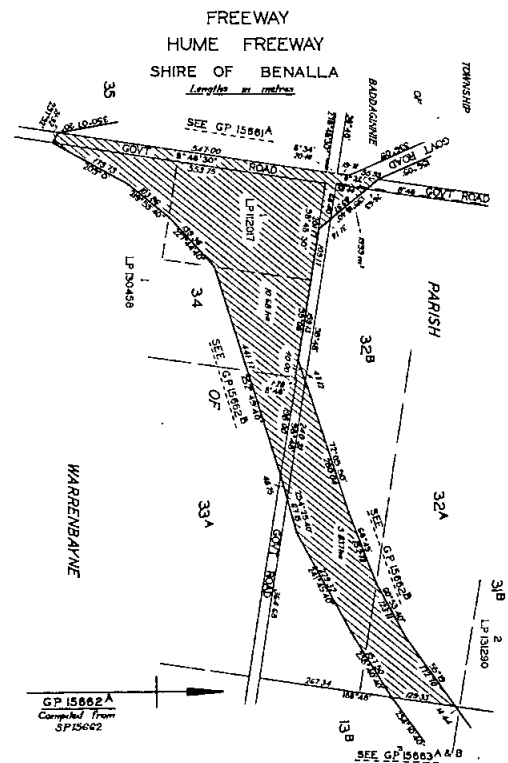
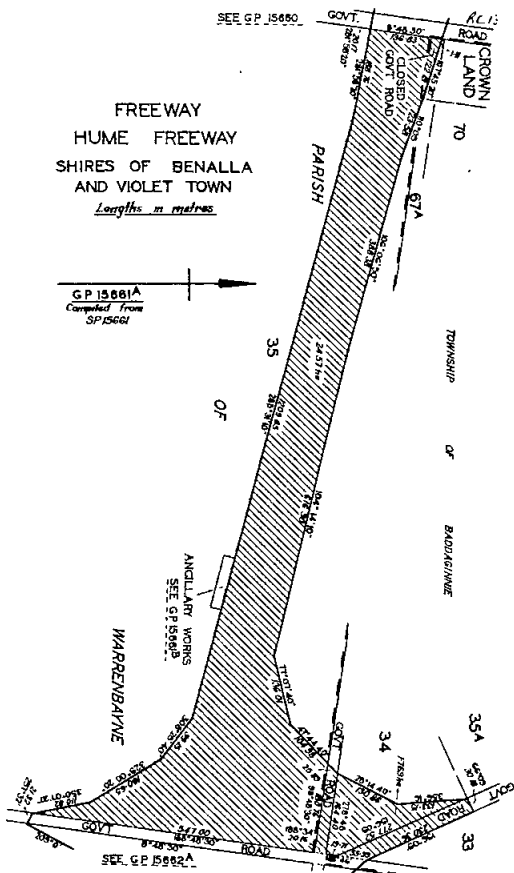

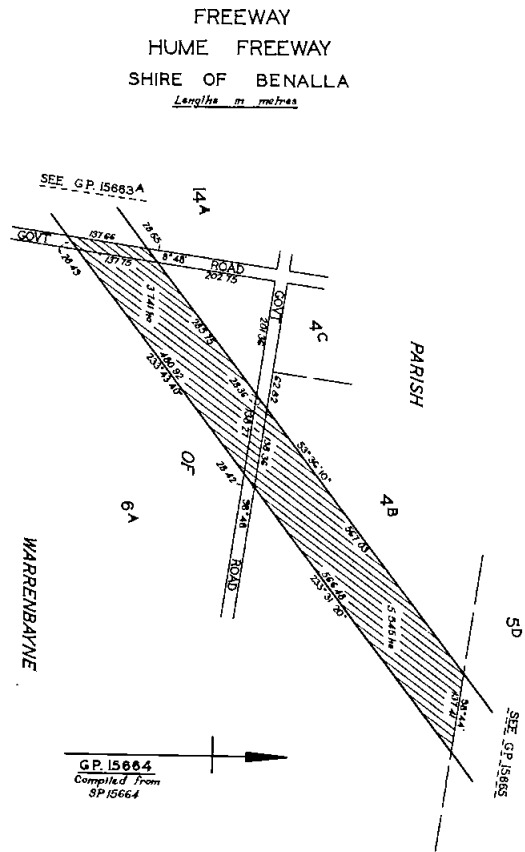
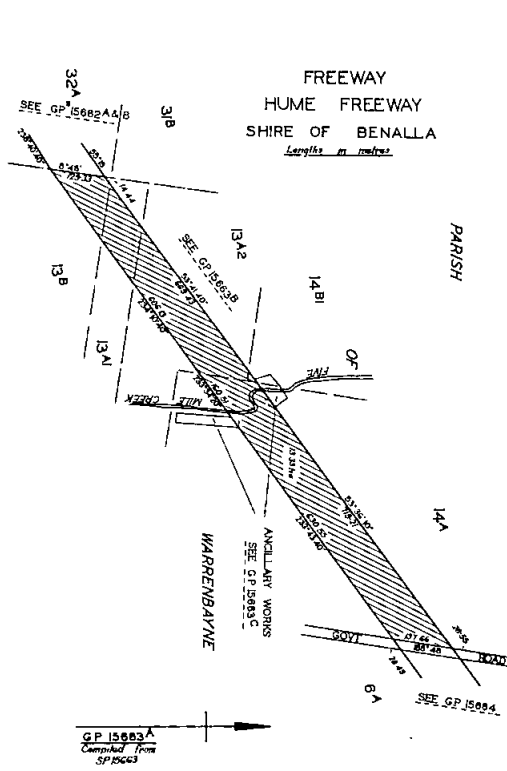

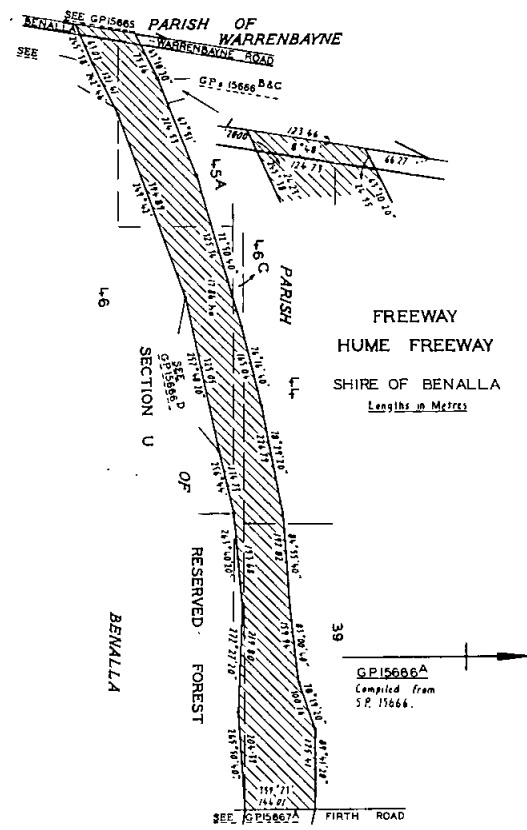
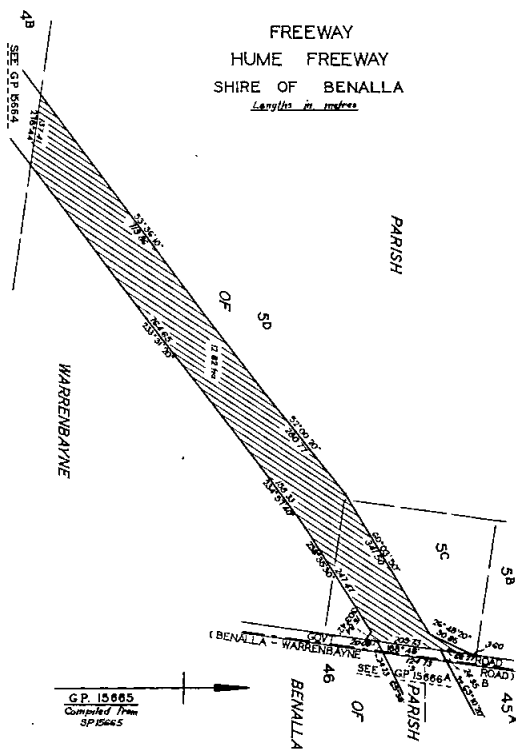

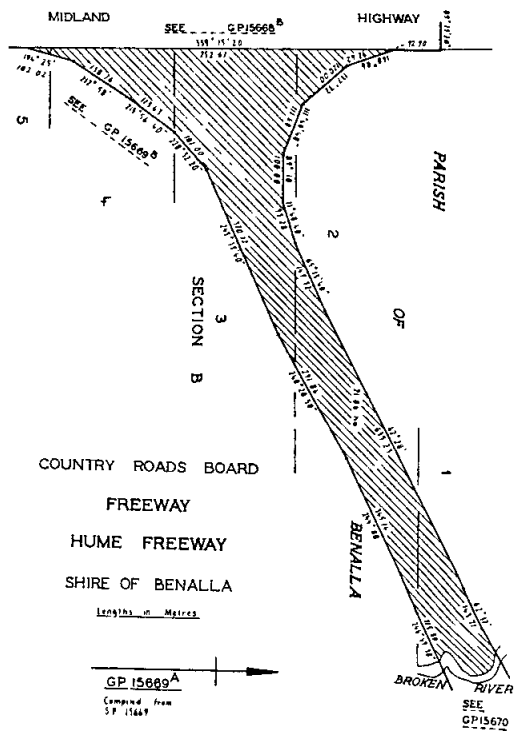
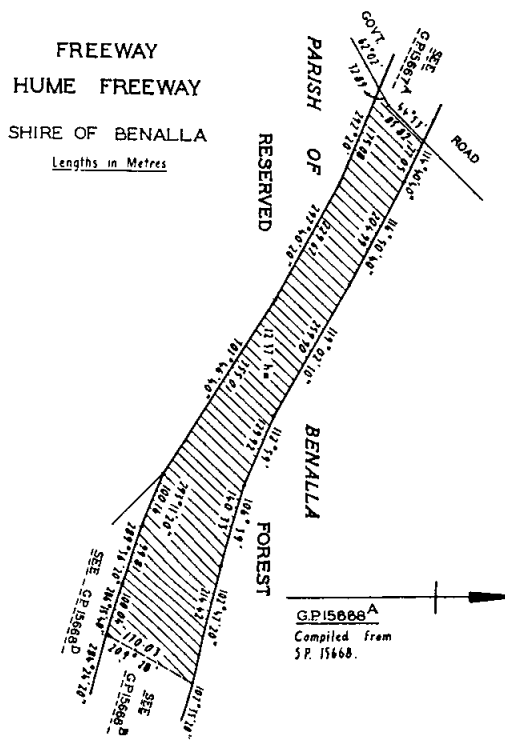
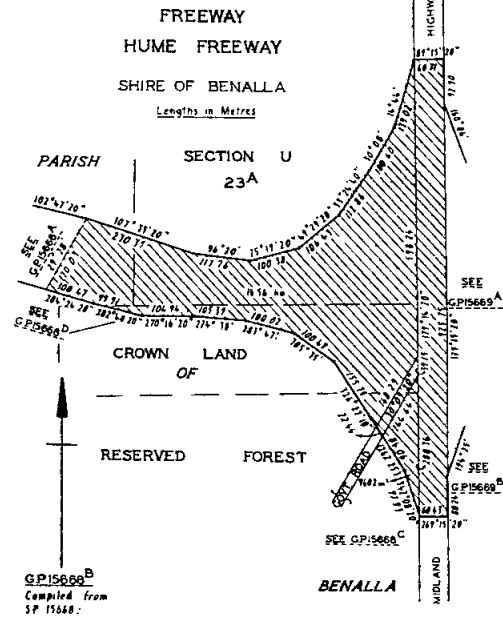
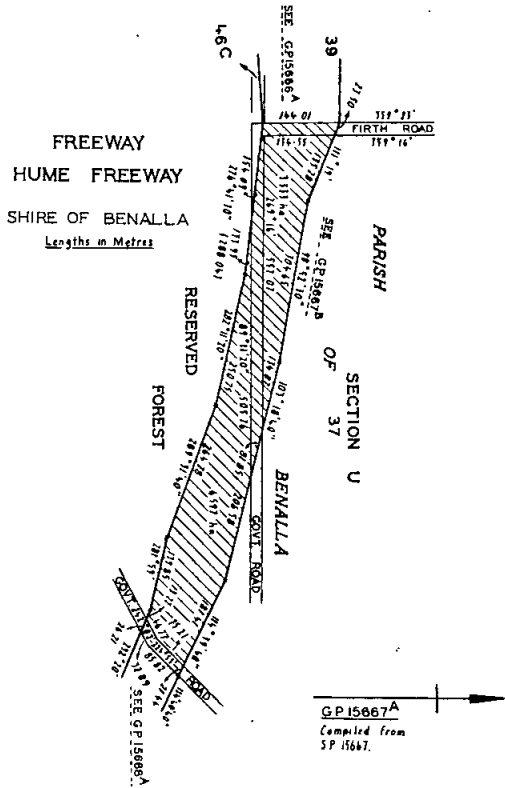

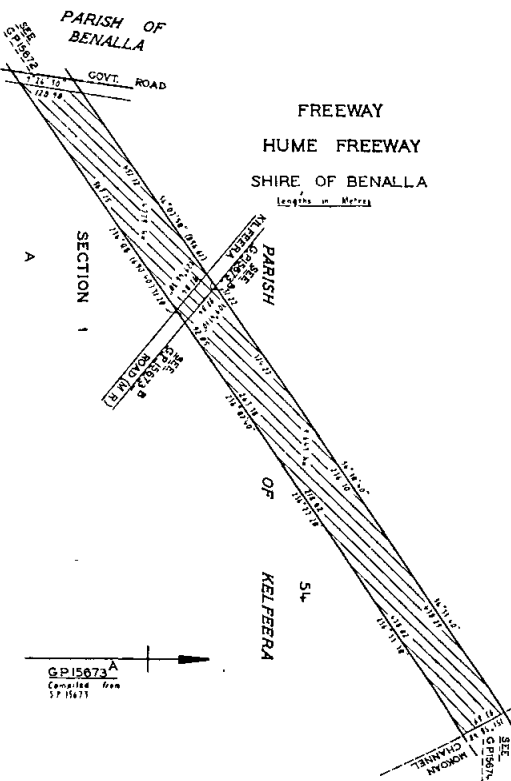
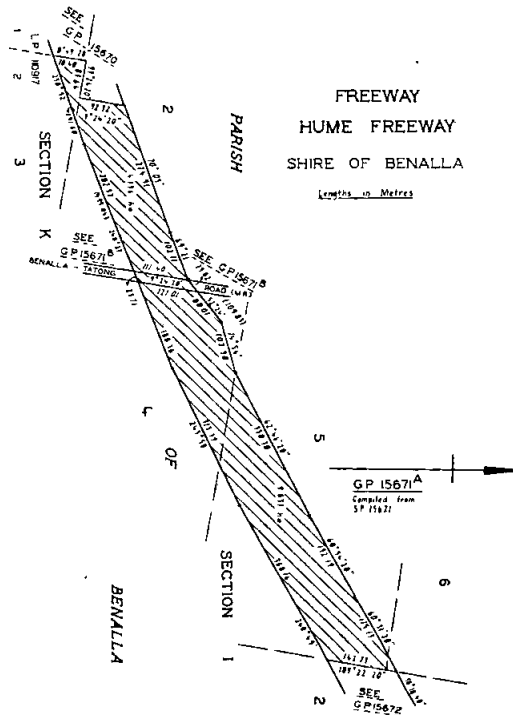
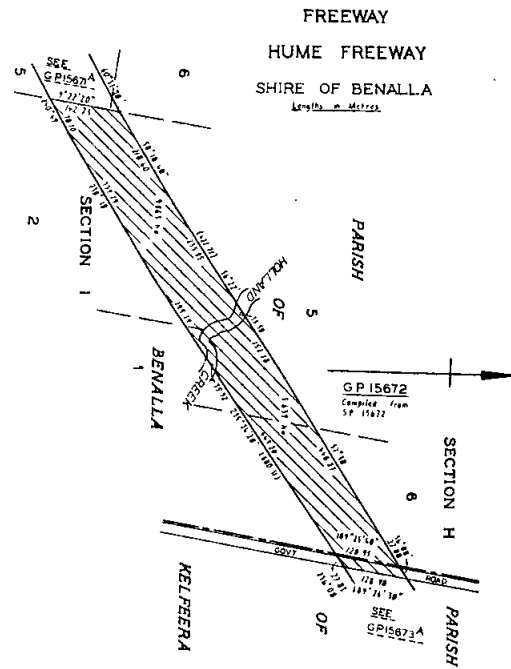
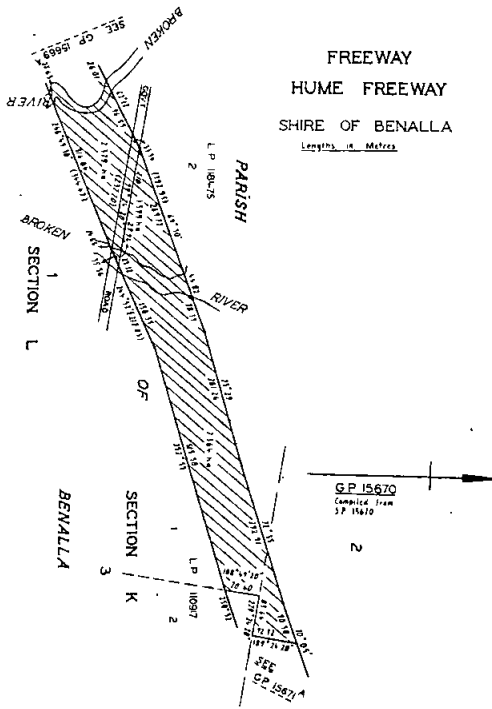

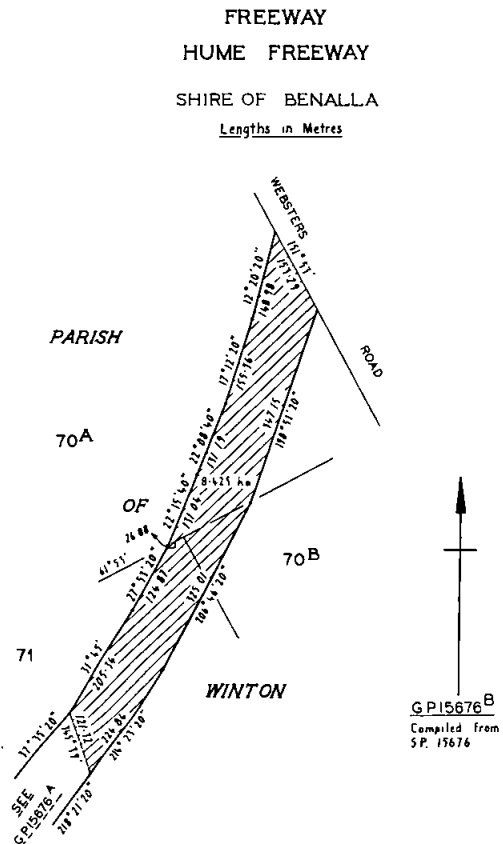
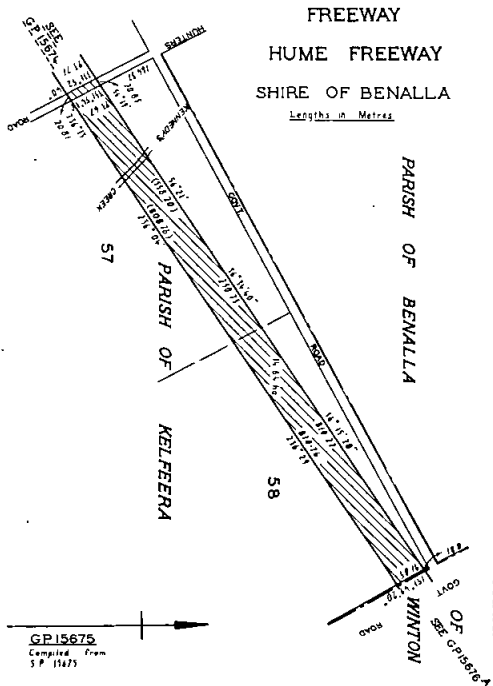
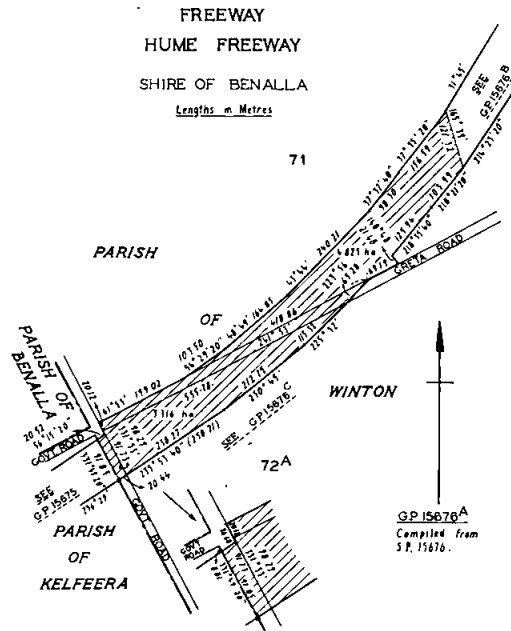
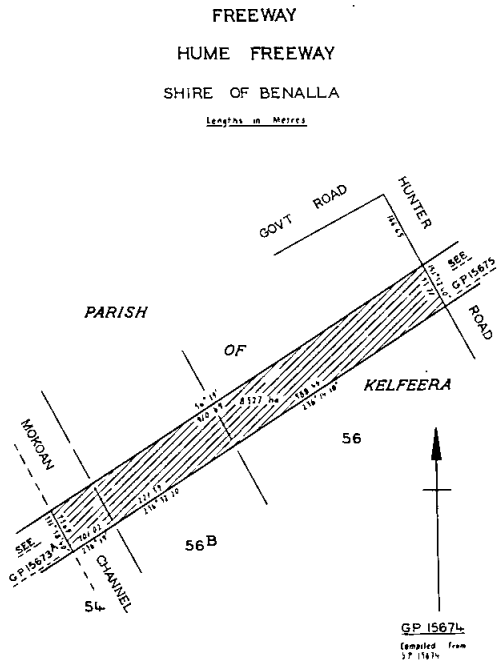

The land shown hatched on plan numbered G.P.15673B hereunder required for Kilfeera Road in the Shire of Benalla.

Widenings of Existing Roads
The land shown hatched on plan numbered G.P.15671B hereunder required for the Benalla-Tatong Road in the Shire of Benalla.

MAIN ROAD
KILFEERA ROAD
SHIRE OF BENALLA
Lengths in Metres

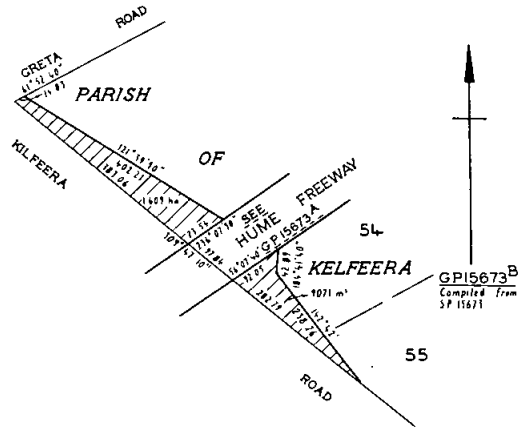
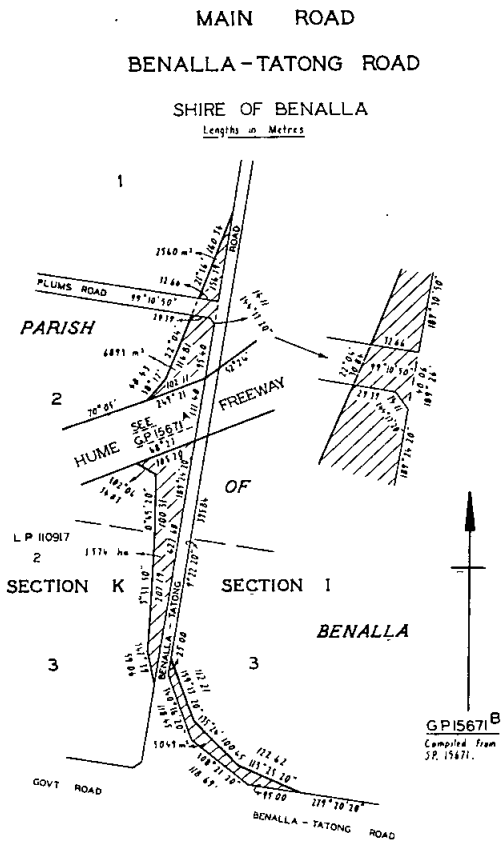

The land shown hatched on plan numbered G.P.15666B hereunder required for the Benalla-Warrenbayne Road in the Shire of Benalla.

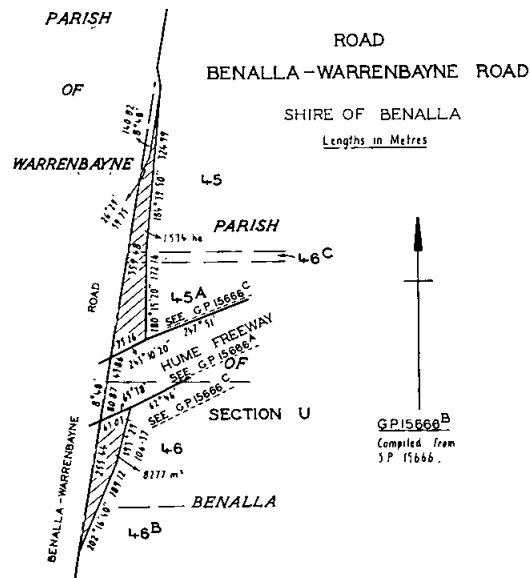

Deviation of an Existing Road

The land shown hatched on plan numbered G.P.15668c hereunder required for the road in the Shire of Benalla.

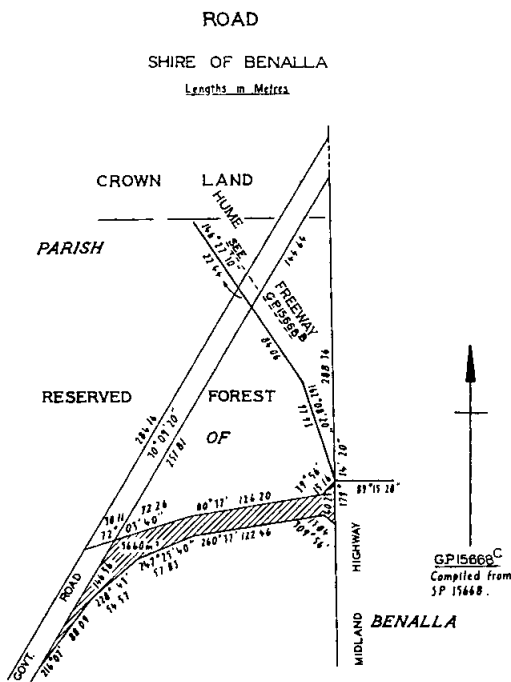

Ancillary Works

The land shown hatched on plans numbered G.P.15661a, G.P.15663c, G.P.15666c, G.P.15668d hereunder required for the (Hume Freeway) in the Shire of Benalla.

ANCILLARY WORKS
(HUME FREEWAY)
SHIRE OF BENALLA
Lengths in metres

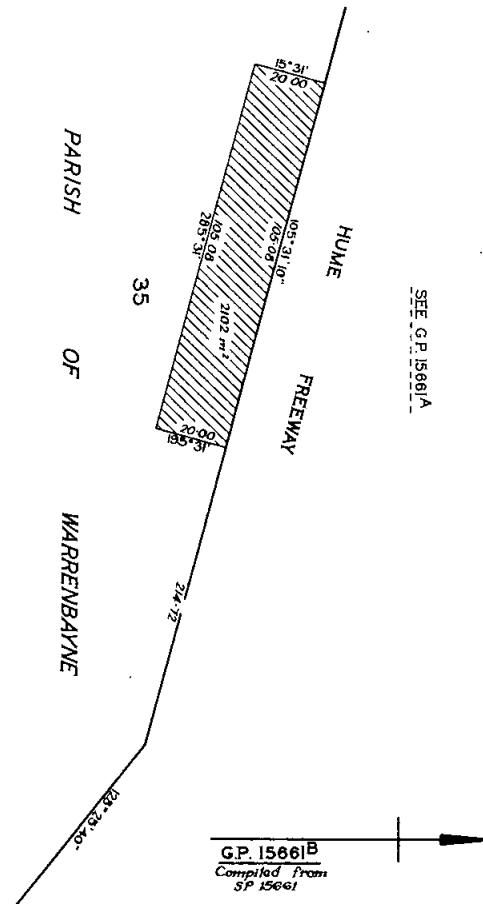

ANCILLARY WORKS
(HUME FREEWAY)
SHIRE OF BENALLA
Lengths in metres

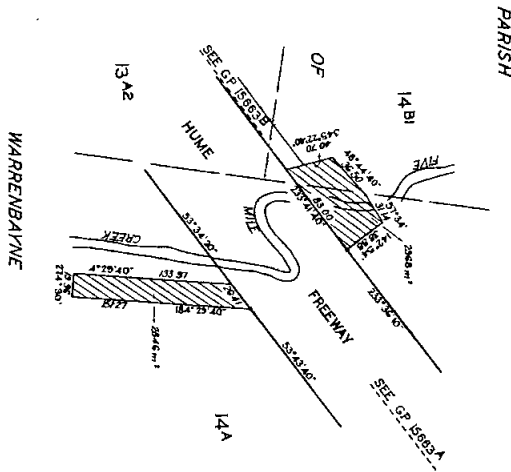

G.P. 15663C
Compiled from
S.P. 15663

ANCILLARY WORKS
(HUME FREEWAY)
SHIRE OF BENALLA
Lengths in Metres

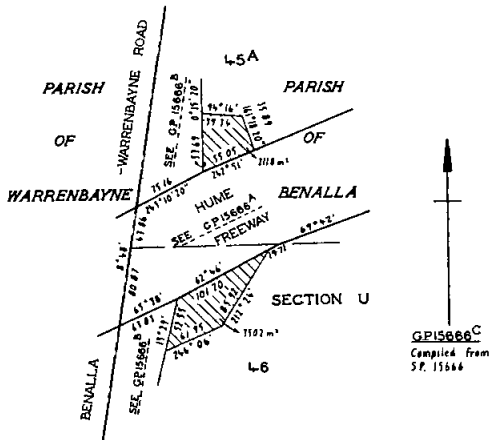

G.P. 15666C
Compiled from
S.P. 15666

ANCILLARY WORKS
(HUME FREEWAY)
SHIRE OF BENALLA
Lengths in Metres

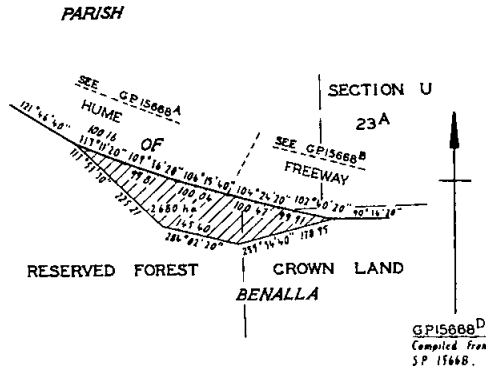

G.P. 15668D
Compiled from
S.P. 15668

Roadside Reserve

The land shown hatched on plan numbered 15666D hereunder required for the (Hume Freeway) in the Shire of Benalla.

ROADSIDE RESERVE
(HUME FREEWAY)
SHIRE OF BENALLA
Lengths in Metres

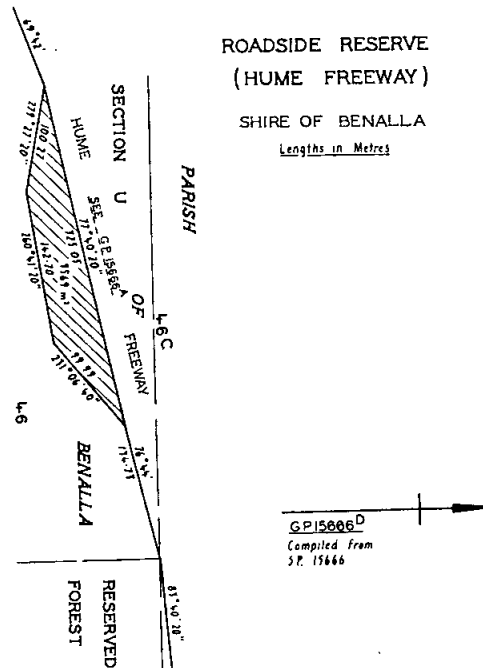

G.P. 15666D
Compiled from
S.P. 15666

And the Honourable Steven Marshall Crabb, Her Majesty's Minister of Transport for the State of Victoria shall give the necessary directions herein accordingly.

L. G. HOUSTON
Acting Clerk of the Executive Council

Parliamentary Committees Act 1968, No. 7727
 REFERENCE TO THE SOCIAL DEVELOPMENT
 COMMITTEE

At the Executive Council Chamber, Melbourne, the
 sixth day of October, 1982

PRESENT:

His Excellency the Governor of Victoria
 Mr Landeryou | Mr Spyker
 Mr Roper | Mr Tresize

INQUIRY INTO ROAD SAFETY IN VICTORIA

Whereas section 4F (1) (a) (ii) of the *Parliamentary Committees Act 1968* provides (*inter alia*) that the Governor in Council by Order published in the *Government Gazette* may refer any proposal, matter or thing relevant to the functions of the Joint Investigatory Social Development Committee under the said Act for inquiry consideration and report to the Parliament.

Now therefore His Excellency the Governor of the State of Victoria, by and with the advice of the Executive Council thereof, and in the exercise of the powers conferred on him by the said Act, doth hereby refer to the said Committee the following matter, namely:

To inquire into, report and make recommendations upon the question of road safety in Victoria, and in particular—

- (a) to specify the accident countermeasures which, in the opinion of the Committee, have been proved to reduce accidents and their consequences;
- (b) to specify the accident countermeasures so proved which are not at present being used in Victoria and which in the opinion of the Committee should be introduced into Victoria;
- (c) to consider whether there are any countermeasures not being used in Victoria which the Committee believes would be likely to achieve a worthwhile reduction in accidents;
- (d) to report on the research which the Committee believes should be undertaken by the State—
 - (i) to obtain more knowledge of accidents; and
 - (ii) to assess the value of present or proposed accident countermeasures;
- (e) to report on any other matters which appear relevant to the inquiry, including—
 - (1) Collisions with Utility Poles and Road-side Fixtures;
 - (2) The Effects of Drugs on Driving;
 - (3) Head and Facial Injuries in Road Accidents;
 - (4) Driver Education;
 - (5) Alcohol and Road Safety; and
 - (6) The 1981 Road Toll.

And the Honourable John Cain, Her Majesty's Premier for the State of Victoria, shall give the necessary directions herein accordingly.

L. G. HOUSTON
 Acting Clerk of the Executive Council

Parliamentary Committees Act 1968, No. 7727
 REFERENCE TO THE ECONOMIC AND BUDGET
 REVIEW COMMITTEE

At the Executive Council Chamber, Melbourne, the
 sixth day of October, 1982

PRESENT:

His Excellency the Governor of Victoria
 Mr Landeryou | Mr Spyker
 Mr Roper | Mr Tresize

INQUIRY INTO THE AUDIT ACT 1958

Whereas section 4F (1) (a) (ii) of the *Parliamentary Committees Act 1968* provides (*inter alia*) that the Governor in Council by Order published in the *Government Gazette* may refer any proposal, matter or thing relevant

to the functions of the Joint Investigatory Economic and Budget Review Committee under the said Act for inquiry consideration and report to the Parliament.

Now therefore His Excellency the Governor of the State of Victoria, by and with the advice of the Executive Council thereof, and in the exercise of the powers conferred on him by the said Act, doth hereby refer to the said Committee the following matter, namely:

To review the *Audit Act 1958* to determine its adequacy and relevance in providing the framework for financial management and accountability in the Victorian Government.

And the Honourable John Cain, Her Majesty's Premier for the State of Victoria, shall give the necessary directions herein accordingly.

L. G. HOUSTON
 Acting Clerk of the Executive Council

RIVER IMPROVEMENT ACT 1958

At the Executive Council Chamber, Melbourne, the
 sixth day of October, 1982

PRESENT:

His Excellency the Governor of Victoria
 Mr Landeryou | Mr Spyker
 Mr Roper | Mr Tresize

YARRA RIVER IMPROVEMENT TRUST—RATING
 DIVISIONS

Under the powers conferred by the *River Improvement Act 1958* and all other powers enabling him in that behalf, His Excellency the Governor of the State of Victoria, by and with the advice of the Executive Council of the said State, doth by this Order repeal, as on and from 31 December 1982, the Order made on 7 July 1968, determining rating divisions in the Yarra River Improvement District, and doth hereby determine that, as on and from 1 January 1983—

- (1) the lands which were affected by the 1934 flood shall be deemed to be those lands which derive benefit from the river improvement works constructed by the Trust for the service of the District;
- (2) all lands from time to time within the District shall be classified in one of five divisions to be known as the First, Second, Third, Fourth and Fifth Divisions;
- (3) the basis for the purpose of classifying the lands in their respective divisions shall be set out in the following Table:

TABLE	
Division	F — W (expressed as a percentage)
First	100%
Second	Not less than 66% to less than 100%
Third	Not less than 4% to less than 66%
Fourth	Greater than 0% to less than 4%
Fifth	0%

Where "F" is the area, at the time of the making of any river improvement rate, of those lands in the same occupation which were flooded by the 1934 flood and "W" is the total area of such lands.

And the Honourable David Ronald White, Her Majesty's Minister of Water Supply for the State of Victoria, shall give the necessary directions herein accordingly.

L. G. HOUSTON
 Acting Clerk of the Executive Council

RIVER IMPROVEMENT ACT 1958

At the Executive Council Chamber, Melbourne, the sixth day of October, 1982

PRESENT:

His Excellency the Governor of Victoria
 Mr Landeryou | Mr Spyker
 Mr Roper | Mr Tresize

YARRA RIVER IMPROVEMENT TRUST
 EXTENT OF DISTRICT INCREASED

Under the powers conferred by the *River Improvement Act 1958* and all other powers enabling him in that behalf, His Excellency the Governor of the State of Victoria, by and with the advice of the Executive Council of the said State of Victoria, doth hereby declare, order and direct as follows:

That the extent of the Yarra River Improvement Trust District be increased by adding to the same the area shown within the red border on the plan titled "Yarra River Improvement Trust Extent of District Increased", approved by the Governor in Council and deposited in the office of the State Rivers and Water Supply Commission, Melbourne and as on and from the date of this Order the extent of the Yarra River Improvement Trust District shall be deemed to be so increased.

And the Honourable David Ronald White, Her Majesty's Minister of Water Supply for the State of Victoria, shall give the necessary directions herein accordingly.

L. G. HOUSTON
 Acting Clerk of the Executive Council

**LANDS DEPARTMENT
 NOTICES**

APPROACHING LAND SALES

Sale of Crown Land, will be held at the under-mentioned places and dates, viz.:

	No. of Gazette
Ballarat—Tuesday, 12 October 1982	81
Piangelil—Friday, 8 October 1982	84

PROPOSED REVOCATION OF TEMPORARY RESERVATION OF LAND BY ORDER IN COUNCIL

In pursuance of the provisions of section 10 of the *Crown Land (Reserves) Act 1978*, notice is hereby given that it is the intention of the Governor in Council to revoke the temporary reservation of land by Order in Council hereunder referred to, viz.:

NINYEUNOOK—The temporary reservation as a site for Camping and affording access to Water and the withholding from sale, leasing and licensing by Order in Council of 9 April 1877 of 8.096 hectares, more or less, of land in the Parish of Ninyeunook (in section 1)—(N.123^(a)) (Rs.11720).

PANNOOBAMAWM—The temporary reservation by Order in Council of 16 May 1892 (see *Government Gazette* dated 20 May 1892, page 2101) of 2.023 hectares of land in the Parish of Pannobamawm (adjoining Cemetery Reserve) as a site for Watering purposes—(Rs.12189).

PANYYABYR—The temporary reservation by Order in Council of 22 December 1964 of 648 hectares, more or less, of land in the Parish of Panyyabyr as a site for Wildlife purposes—(P.126^(a)) (Rs.8363).

PANYYABYR—The temporary reservation by Order in Council of 14 May 1974 of 1.214 hectares, being Crown allotment 90B, Parish of Panyyabyr as a site for Public Purposes (Conservation of Wildlife)—(P.126^(a)) (Rs.8363).

RAINBOW—The temporary reservation by Order in Council of 31 March 1905 of 1.214 hectares of land in the Township of Rainbow (called Parish of Werrap in Order) as a site for a Manure Depot—(R.89^(a)) (Rs.12153).

BALLARAT EAST—The temporary reservation by Order in Council of 5 March 1974 of 1.462 hectares of land in the Township of Ballarat East, as a site of Public Purposes (Educational Purposes), so far only as the portion thereof containing 618 square metres, as indicated by hatching on plan hereunder, is concerned—(B.128^(a)) (Rs.2789).

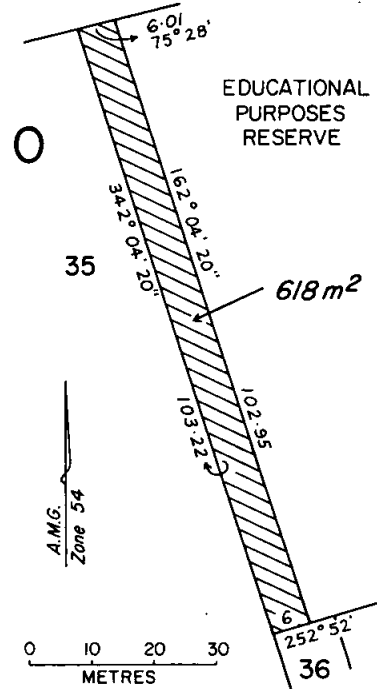

BOROONDARA (KEW)—The temporary reservation by Order in Council of 5 July 1869 of 23.47 hectares, more or less, of land in the Parish of Boroondara as a site for Mental Hospital purposes, revoked as to part by various Orders and various Acts, so far only as the portion thereof containing 2.1 hectares, more or less, as indicated by hatching on plan hereunder, is concerned—(B.415^(a)) (Rs.7734).

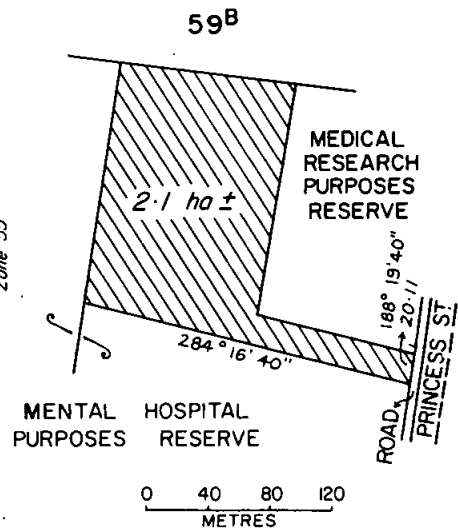

BOROONDARA (KEW)—The temporary reservation by Order in Council of 26 March 1935 of 74.98 hectares, more or less, of land in the Parish of Boroondara as a site for a Mental Hospital, revoked as to part by various Orders and by Act No. 6594, so far only as the portion thereof containing 1.4 hectares, more or less, as indicated by hatching on plan hereunder, is concerned—(B.415⁽²⁾) (Rs.7734).

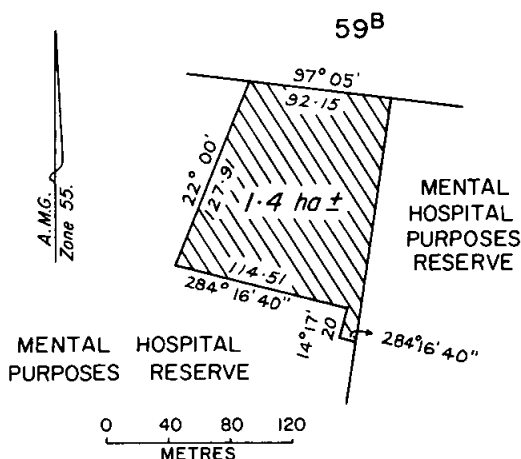

R. A. MACKENZIE
Minister of Lands

Department of Crown Lands and Survey
Melbourne

REGULATIONS FOR THE CARE, PROTECTION AND MANAGEMENT OF THE BELLAURA PUBLIC PURPOSES (SUPPLY OF GRAVEL) RESERVE

I, Roderick Alexander Mackenzie, Her Majesty's Minister of Lands, in and for the State of Victoria, in pursuance of the powers conferred on me by section 13 of the *Crown Land (Reserves) Act 1978*, do hereby make the following Regulations for or with respect to the Crown Land in the Parish of Bellaura (hereafter referred to as the "Reserve") temporarily reserved as a site for Public Purposes (Supply of Gravel) by Order in Council dated 18 April 1968 (*vide Government Gazette* of 24 April 1968).

The Reserve has been placed under the control of the Corporation of the Shire of Stawell as the Committee of Management (hereafter referred to as "the Committee") pursuant to section 14 of the *Crown Land (Reserves) Act 1978* with power and authority to enforce the following Regulations:

REGULATIONS

1. No person shall remove from the Reserve any soil, sand, loam, gravel or other material except with the written permission of the Committee or Engineer to the Shire of Stawell or other persons authorized by the Committee, and then only subject to the observance of such terms and conditions and the payment of such fees as may be prescribed by the Committee from time to time.
2. No person shall without the written consent of the Committee—
 - (a) camp within the Reserve or light or maintain any fire therein;
 - (b) deposit any rubbish, debris, litter or other unwanted material or thing of any kind;
 - (c) interfere with or remove or damage or destroy any fences, tracks, signs, earthen banks or any other improvements or structures;
 - (d) cut, damage or remove any trees or plants growing in the Reserve;
 - (e) allow any cattle, horses, sheep, goats, pigs or other animals to enter or remain in the Reserve—(Rs.8977).

Given under my hand at Melbourne, on 29 September 1982

R. A. MACKENZIE
Minister of Lands

Every person who contravenes or fails to comply with these Regulations shall be liable to the penalties prescribed in section 13 of the *Crown Land (Reserves) Act 1978*.

TENDERS

PUBLIC WORKS DEPARTMENT

Tenders are invited for the purposes indicated hereunder and will be received at 2 Treasury Place, Melbourne, 3002, until TWO p.m. on dates shown.

Tenders must be addressed to the Minister of Public Works with the envelope endorsed "Tender for

". Hand-delivered tenders must be placed in the Department's tender box in the foyer, Ground Floor, 2 Treasury Place, Melbourne.

Tenders documents are available from the Contracts Office, Room 29, 2 Treasury Place, Melbourne and where indicated, at offices of Inspectors of Works.

★ Tenders for works identified with star (★) will only be considered from Contractors qualified for repairs and painting works. Any Tenderers wishing to qualify may obtain the application form from the Contracts Office.

Tuesday, 19 October 1982

Building, Electrical and Mechanical Services

★LILYDALE—External and part internal renovations, Technical School. (Re-advertised and amended.)

LUCKNOW—Demolition of fire damaged toilet block and erection of new toilet block, Primary School. (W.O. Bairnsdale.)

MOE—New toilet block, Primary School. (W.O. Traralgon.)

★OAK PARK—External and part internal renovations and painting, Primary School.

★SEYMOUR—Cyclic maintenance, Primary School. (W.O. Shepparton.)

Miscellaneous

ECHUCA—Supply of engines, Technical School.

Tuesday, 26 October 1982

Building, Electrical and Mechanical Services

BAIRNSDALE—Fitting out works, 212 Main Street, Ministry for Conservation. (W.O. Bairnsdale.)

★BAIRNSDALE—Internal and external repairs and painting, electrical, mechanical and civil works, High School. (W.O. Bairnsdale.)

BALLARAT—(Readvertisement)—Renovations, alterations and painting, Novar House, Lake Hospital. (W.O. Ballarat.)

★BLACKBURN NORTH—External cyclic maintenance, Primary School.

★FRANKSTON—Internal repairs, painting and electrical and mechanical works, High School.

★KENT PARK—External cyclic maintenance, Primary School.

★KORUMBURRA—Internal and external renovations, High School. (W.O. Traralgon.)

★LEONGATHA—Internal and external repairs and painting (building, electrical, mechanical and acoustic upgrade), Technical School. (W.O. Traralgon.)

★MIDDLEFIELD—External cyclic maintenance, Primary School.

★MONASH—External cyclic maintenance, Primary School.

★NARMARA—External cyclic maintenance, Primary School.

★PASCOE VALE NORTH—Internal and external repairs and painting, Primary School.

★SYNDAL SOUTH—Painting and repairs, Primary School.

★WAVERLEY MEADOWS—External repairs and painting, Primary School.

★WONTHAGGI—Internal and external repairs and painting, High School. (W.O. Korumburra.)

Miscellaneous

MELBOURNE—Supply of trailer mounted alternator sets, Russell Street Police H.Q. (Re-advertised and amended.)

MELBOURNE—Expansion of radio control equipment, Russell Street Police H.Q.

PORT MELBOURNE—Purchase of (2) two only chassis and cabin—G.C.M.—32 tonne (70 000 lb), P.W.D. Storeyard, Salmon Street.

PORT MELBOURNE—Manufacture and delivery of manual jetty cranes, P.W.D. Storeyard, Salmon Street.

Tuesday, 16 November 1982

Miscellaneous

MELBOURNE—Supply of U.H.F. radio network (metro. base stations), Police Complex, Russell Street.

JACK SIMPSON, M.P.
Minister of Public Works

Public Works Department
Melbourne, 5 October 1982

PRIVATE ADVERTISEMENTS

CITY OF BERWICK

LOAN No. 67

*Notice of Intention to Borrow the Sum of \$120 000 for
Permanent Works and Undertakings*

Notice is hereby given that the Council of the City of Berwick proposes to borrow the principal sum of \$120 000 secured by a charge over the general rates of the municipality, such sum to be raised by the grant of a mortgage in accordance with the provisions of the *Local Government Act 1958*.

1. Maximum rate of interest that may be paid is 15.8 per centum per annum.

2. The purpose for which the loan is to be applied:

Construction—Municipal Branch Library, \$120 000
Autumn Place, Doveton

3. The period of the loan shall be ten years.

4. The moneys borrowed shall be repayable by providing out of the Municipal Fund 20 half-yearly instalments of approximately \$12 131.45 each including principal and interest, on 1 July and 1 December during the currency of the loan. The first instalment shall be payable on 1 July 1983.

5. Such moneys shall be repayable to the Local Authorities Superannuation Board, Rigby House, 15 Queens Road, Melbourne, 3004, or such other places as the Board may from time to time require.

The plans and specifications and the estimate of the cost of the proposed works and a statement showing the proposed expenditure of the moneys to be borrowed are open for inspection at the office of the Council of the City of Berwick, Civic Centre, Princes Highway, Fountain Gate, Narre Warren.

Dated 6 October 1982

3043

P. J. NORTHEAST, City Manager

CITY OF KEW

BY-LAW No. 114

Notice is hereby given that in pursuance of the powers conferred by section 197 of the *Local Government Act 1958*, the Council of the City of Kew has made a By-law numbered 114 for the purpose of repealing By-law No. 113 and regulating the proceedings of Council meetings, Committee meetings and for other purposes.

The resolution for the By-law was agreed to on 6 July 1982, and confirmed on 28 September 1982.

A copy of the By-law is open for inspection during office hours at the Municipal Offices, Charles Street, Kew, 3046

L. FELL, City Manager

CITY OF SALE

LOAN No. 126

Notice of Intention to Borrow the Sum of \$33 000

Notice is hereby given that the Council of the City of Sale proposes to borrow the principal sum of \$33 000 secured by a charge over the general rates of the municipality, such sum to be raised by the grant of a mortgage in accordance with the provisions of the *Local Government Act 1958*.

1. The maximum rate of interest that may be paid is 17.5 per cent per annum.

2. The purpose for which the loan is to be applied is to liquidate a previous loan No. 65 which was for \$50 000 and was for part cost of the Sale Swimming Complex.

3. The period of the loan shall be ten years.

4. The moneys borrowed shall be repayable by providing out of the municipal fund half-yearly instalments of approximately \$3550.86 each including principal and interest on 11 May and 11 November during the currency of the loan. The first instalment shall be payable on 11 May 1983.

5. Such moneys shall be repayable to the Australia and New Zealand Savings Bank Ltd., 55 Collins Street, Melbourne.

3047

JOHN L. LOW, Town Clerk

Town and Country Planning Act 1961

SHIRE OF BASS PLANNING SCHEME

NOTICE THAT A PLANNING SCHEME HAS BEEN PREPARED
AND IS AVAILABLE FOR INSPECTION

Amendment No. 5

Notice is hereby given that the Shire of Bass in pursuance of its powers under the *Town and Country Planning Act 1961* has prepared a planning scheme for the area known as the Anderson Peninsula. The planning scheme proposes to make provision for Rural Residential development and to facilitate the restructure of existing subdivisions.

A copy of the scheme has been deposited at the Shire Office, Archies Creek, the State Offices 33-39 High Street, Cranbourne and at the office of the Department of Planning (Plan inspection Section) 5th Floor, 235 Queen Street, Melbourne and will be open for inspection during office hours by any person free of charge.

Any persons affected by the scheme are required to set forth in writing any submissions they may wish to make with respect to the scheme, addressed to the Shire Secretary, Shire Office, Archies Creek, 3992 by 6 January 1983 and to state whether they wish to be heard in respect of their submissions.

Dated 6 October 1982

3037

G. J. HARLAND, Shire Secretary

Town and Country Planning Act 1961

SHIRE OF BASS PLANNING SCHEME

NOTICE THAT A PLANNING SCHEME HAS BEEN PREPARED
AND IS AVAILABLE FOR INSPECTION

Amendment No. 7

Notice is hereby given that the Shire of Bass in pursuance of its powers under the *Town and Country Planning Act 1961* has prepared a planning scheme for the area known as O'Connor subdivision being lots 1-51 inclusive LP 53116 Agar Road, Coronet Bay. The planning scheme proposes to prepare a Restructure Plan for the subdivision.

A copy of the scheme has been deposited at the Shire Office, Archies Creek, the State Offices 33-39 High Street, Cranbourne and at the office of the Department of Planning (Plan Inspection Section) 5th Floor, 235 Queen Street, Melbourne and will be open for inspection during office hours by any person free of charge.

Any persons affected by the scheme are required to set forth in writing any submissions they may wish to make with respect to the scheme, addressed to the Shire Secretary, Shire Office, Archies Creek, 3992 by 6 November 1982 and to state whether they wish to be heard in respect of their submissions.

6 October 1982

3038

G. J. HARLAND, Shire Secretary

Town and Country Planning Act 1961 (Twelfth Schedule)

SHIRE OF BASS PLANNING SCHEME

NOTICE THAT A PLANNING SCHEME HAS BEEN PREPARED AND IS AVAILABLE FOR INSPECTION

Amendment No. 8

Notice is hereby given that the Shire of Bass in pursuance of its powers under the *Town and Country Planning Act 1961* has prepared a Planning Scheme to make provision for the widening of the Phillip Island Tourist Road adjacent to Crown Allotments 10B, 10C and 11, Township of San Remo, Parish of Woolamai.

A copy of the scheme has been deposited at the Shire Office, Archies Creek and at the office of the Department of Planning (Plan Inspection Section), 5th Floor, 235 Queen Street, Melbourne, and will be open for inspection during office hours by any person free of charge.

Any persons affected by the scheme are required to set forth in writing any submissions they may wish to make with respect to the scheme, addressed to the Shire Secretary, Shire of Bass, Shire Offices, Archies Creek, by 6 January 1983, and to state whether they wish to be heard in respect of their submissions.

30 September 1982

3105

G. J. HARLAND, Shire Secretary

SHIRE OF HEALESVILLE

By-LAW No. 58

Library By-law

Under the provisions of section 197 of the Local Government Act, Council on 31 August 1982 confirmed the making of a By-law for the purpose of—

(a) Regulating the management and control of library services provided by the Council jointly with the Eastern Regional Libraries Committee.

(b) Imposing penalties not exceeding \$100 for breaches of this By-law.

A copy of the By-law is open for inspection, free of charge, during office hours at the Shire Office, 231 Marondah Highway, Healesville.

3044

G. R. PEACOCK, Shire Secretary

Town and Country Planning Act 1961

SHIRE OF KILMORE PLANNING SCHEME 1973

NOTICE THAT A PLANNING SCHEME HAS BEEN PREPARED AND IS AVAILABLE FOR INSPECTION

Amendment No. 53, 1982

Notice is hereby given that the Shire of Kilmore, in pursuance of its powers under the *Town and Country Planning Act 1961*, has prepared a Planning Scheme for land known as Crown Allotment 3, Section 23, Parish of Wallan Wallan known as 126-128 High Street, Wallan and contained in Volume 9421 Folio 277. The purpose of the Scheme is to rezone the said land from its present zoning "Special Use (Church)" to "Industrial 'A'".

A copy of the said Scheme has been deposited at the office of the Shire of Kilmore, Civic Centre, Sydney Street, Kilmore and at the Office of the Department of Planning, 235 Queen Street, Melbourne, and will be open for inspection during office hours by any person free of charge.

Any persons affected by the Planning Scheme are required to set forth in writing all objections they may have addressed to the Shire Secretary, Shire of Kilmore, Civic Centre, Sydney Street, Kilmore on or before 8 November 1982 and to state whether they wish to be heard in respect to their objections.

4 October 1982

3104

JIM ELVEY, Shire Secretary

SHIRE OF MANSFIELD SEWERAGE AUTHORITY

(BONNIE DOON URBAN DISTRICT)

The Authority hereby gives notice of its intention to construct sewers, manholes and associated works along Kitchen Street in the Township of Bonnie Doon.

Plans are available for inspection at the Authority Office during office hours.

G. D. PAYNE, Secretary

Shire of Mansfield Sewerage Authority

48 High Street, Mansfield, 3722

3048

Town and Country Planning Act 1961

SHIRE OF MILDURA PLANNING SCHEME

INTERIM DEVELOPMENT ORDER No. 5, 1981

Notice that an Amendment to an Interim Development Order has been Prepared and is Available for Inspection

Notice is hereby given that the Council of the Shire of Mildura in pursuance of its powers under the *Town and Country Planning Act 1961* has prepared an Interim Development Order known as Amendment No. 1 to the Shire of Mildura Interim Development Order No. 5, 1981 for the addition of the definition of an Adult Sex Book and Sex Aid Establishment to be included in the Interim Development Order and for the amendment to Column 2, Table 1, Clause 18 of the Order making such an establishment a discretionary use within the Urban Zone of the Interim Development Order.

A copy of the Interim Development Order has been deposited at the Offices of the Responsible Authority, Fifteenth Street, Irymple, and at the office of the *Town and Country Planning Board*, 235 Queen Street, Melbourne and will be open for inspection, during office hours, by any person, free of charge.

Any persons affected by the Amendment to the Interim Development Order are required to set forth in writing all objections they may have, addressed to the Shire Secretary, Shire of Mildura, P.O. Box 366, Irymple 3498, on or before 6 November 1982, and to state whether they wish to be heard in respect of their objections.

Dated 6 October 1982

3030

D. J. McMILLAN, Shire Secretary

SHIRE OF MILDURA

NOTICE OF INTENTION TO ACQUIRE LAND COMPULSORILY

Notice is hereby given that the Council of the Shire of Mildura has deemed it expedient to exercise its powers of taking land compulsorily for the work or undertaking mentioned hereunder.

(1) The Council intends to acquire compulsorily an area of land being 1926 square metres Part Lot 8A, Section 6, Block F, Parish of Mildura (Part Crown Portion 47) to be used for the proposed realignment of Irymple Avenue, Nichols Point.

(2) A copy of a plan of such land and a Schedule of the parties having interests therein are deposited at the Municipal Offices at Irymple and are there available for inspection by all interested parties during office hours free of charge for the period of 40 clear days from the date of publication of this Notice in the *Government Gazette*.

(3) The Council hereby requires all persons affected by the said proposal to set forth in writing addressed to the Shire Secretary, Shire of Mildura, Shire Offices, Irymple, 3498 within 40 clear days from the date of publication aforesaid all objections which they may have to the taking of the said land.

(4) At the Ordinary meeting of the Council next after the expiration of the said 40 clear days the Council will consider any such objection and any person so objecting as aforesaid may appear before the Council in support of such objection.

Dated 6 October 1982

By order of the Council
3045 D. J. McMILLAN, Shire Secretary

SHIRE OF MORTLAKE

LOAN No. 39

Notice of Intention to Borrow the Sum of \$30 000 for Permanent Works and Undertakings

Notice is hereby given that the Council of the Shire of Mortlake proposes to borrow the principal sum of \$30 000, secured by a charge over the general rate of the municipality, such sum to be raised by the grant of a mortgage in accordance with the provisions of the Local Government Act 1958.

1. The maximum rate of interest that may be paid is 14.4% per annum.
2. The purpose for which the loan is to be raised is the Construction of Underground Drainage in Mortlake.
3. The period of the loan shall be four (4) years.
4. The monies borrowed shall be repayable by providing out of the Municipal Fund seven half-yearly instalments of approximately \$2 875.96 each, including principal and interest, on 18 May and 18 November, during the currency of the loan, with a final instalment of the amount then owing. The first instalment shall be payable on 18 May 1983.
5. Such monies shall be payable at the C.B.C. Savings Bank Ltd., Melbourne.

The specification and estimate of cost of the proposed undertaking and a statement of the proposed expenditure of the monies to be borrowed are open for inspection at the office of the Shire of Mortlake at 1 Jamieson Avenue, Mortlake.

3103 K. E. LIEBOLD, Shire Secretary

SHIRE OF NEWHAM AND WOODEND

LOAN No. 51

Notice of Intention to Borrow the Sum of \$120 000 for Permanent Works and Undertakings

Notice is hereby given that the Council of the Shire of Newham and Woodend proposes to borrow the principal sum of One hundred and twenty thousand dollars (\$120 000) secured by a charge over the general rates of the municipality, such sum to be raised by the grant of a mortgage in accordance with the provisions of the Local Government Act 1958.

1. The amount of the principal monies which it is proposed to borrow is One hundred and twenty thousand dollars (\$120 000).
2. The maximum rate of interest that may be paid is 17.3 per centum per annum.
3. The purpose for which the loan is to be applied is for construction of Woodend Swimming Pool and Tennis Courts complex and associated capital works—\$120 000.
4. The period of the loan shall be four years.
5. The monies borrowed shall be repayable by providing out of the municipal fund seven half-yearly instalments of approximately \$10 770 each including principal and interest on 10 April and 10 October during the currency of the loan with the final instalment of \$126 523 to be paid on 10 October 1986. The first instalment shall be payable on 10 April 1983.
6. Such monies shall be repayable to the Commercial Bank of Australia Limited, 114 William Street, Melbourne.

The plans and specifications and the estimate of the cost of the proposed works and a statement showing the proposed expenditure of the moneys to be borrowed are open for inspection at the Municipal Offices, 92 High Street, Woodend.

Dated 21. September 1982

3039 GEOFF KOHLMAN, Shire Secretary

DAYLESFORD SEWERAGE AUTHORITY

COMMENCEMENT OF WORKS

Notice is hereby given that the Authority intends to construct sewers in the following areas:

(a) Reticulation Stage 2

In the general area bounded by Westwood Street, Smith Street, Raglan Street and west of Vincent Street, Daylesford.

(b) Trunk Sewer Stage 2

Generally through land adjacent to Doctors Gully between Westwood Street, Daylesford and Fifth Street, Hepburn.

Details of the proposed works are available for inspection at the Office of the Authority, 33 Albert Street, Daylesford during normal office hours.

3031

P. A. INGLE, Secretary

DANDENONG SEWERAGE AUTHORITY

GENERAL NOTICE

The abovementioned Sewerage Authority having made provision for carrying off the sewage from each and every property which, or any part of which is within the sewerage areas hereinafter described, doth hereby declare that on and after 1 October 1982, each and every property which, or part of which is within the said sewerage areas shall be deemed to be seweraged property within the meaning of the Sewerage Districts Act 1958.

The boundaries of the Sewerage Areas hereinbefore referred to are:

Sewerage Area No. 445

All those pieces of land being Lots 87 and 95 inclusive, 138 to 153 inclusive and 267 to 270 inclusive on Lodged Plan of Subdivision No. 138821; Lots 79 to 86 inclusive, 130 to 137 inclusive, 154 to 160 inclusive and 193 to 207 inclusive of Lodged Plan of Subdivision No. 139620.

Streets or parts thereof in this area are Clifton Way, Eddington Place, Hamilton Close, Mildura Crescent and Nareen Avenue.

Sewerage Area No. 446

All that piece of land being Lot 2 on Lodged Plan of Subdivision No. 87828 such lot having frontage to the western side of Frankston Road.

Sewerage Area No. 447

All those pieces of land being Lots 2828 to 2834 inclusive on Lodged Plan of Subdivision No. 139305 and Lots 2814 to 2827 inclusive on Lodged Plan of Subdivision No. 139306.

Streets or parts thereof in this area are Bass Place, John Edgecumbe Way and William Hovell Drive.

Sewerage Area No. 448

All those pieces of land being Lots 1 to 38 inclusive on Lodged Plan of Subdivision No. 141145.

Streets or parts thereof in this area are Brady Road, Cardinia Close and Sylvan Court.

Sewerage Area No. 449

All that piece of land described in Certificate of Title Volume 4721 Folio 014 such land being situated on the southern side of Bridge Road, 77.30 metres north of Futura Road, Keysborough.

Sewerage Area No. 450

Commencing at a point on the south-western side of Hanna Street, such point being the northern angle of Lot 2 on Lodged Plan of Subdivision No. 45682; thence generally southerly along the western side of the said Lot 2 to its south-western angle; thence easterly by a line bearing 77 deg. 59 min. a distance of 10.84 metres; thence south-easterly by a line 108 deg. 17 min. 40 sec. a distance of 98.25 metres to the southern angle of the said Lot 2; thence northerly by a line bearing 0 deg. 0 min. to the south-western side of Hanna Street; thence north-westerly along the south-western side of Hanna Street to the point of commencement.

Sewerage Area No. 451

All that piece of land being Lot 2 on Lodged Plan of Subdivision No. 121151 such lot having frontage to the eastern side of Hammond Road, Dandenong South.

Sewerage Area No. 452

All those pieces of land being Lots 58 to 72 inclusive on Lodged Plan of Subdivision No. 138942.

Streets or parts thereof in this area are Bellbrook Drive and Outlook Drive, Dandenong North.

Unless otherwise specified, the Lodged Plans of Subdivision hereinbefore referred to shall be taken as those lodged at the Office of Titles, Melbourne.

By order of the Dandenong Sewerage Authority

G. J. CHUDLEIGH, Chairman
A. L. FOSTER, Acting Secretary/Manager
3036

THE BALLARAT SEWERAGE AUTHORITY

Pursuant to section 119 (2) of the *Sewerage Districts Act 1958* (No. 6368) notice is hereby given of the intention to construct a sewer for property situated in the vicinity of the following streets:

Sturt and Pleasant Streets, Ballarat, and 1713-1717 Geelong Road, Mt. Helen.

More particularly as shown on plans which are open for inspection at this office between the hours of 8.45 a.m. and 4.30 p.m., Monday to Friday, inclusive.

Water and Sewerage Offices
Grenville Street, South Ballarat, 3350

3042 B. E. LEACH, Secretary

BENDIGO SEWERAGE AUTHORITY**GENERAL NOTICE**

The above-mentioned Sewerage Authority having made provision for carrying off the sewage from each and every property which or any part of which is within the sewerage area hereinafter described doth hereby declare that on and after 1 October 1982, each and every property which or any part of which is within the said sewerage area shall be deemed to be a seweraged property within the meaning of the *Sewerage Districts Act 1958*.

The boundaries of the sewerage areas hereinbefore referred to are:

445 Lawson Street
446 Regent Street
447 Burns Street
448 Wattle Drive

as shown on plans which may be inspected at the office of the Authority or of the State Rivers and Water Supply Commission, Orrong Road, Armadale.

Dated 30 September 1982

By order of the Bendigo Sewerage Authority

R. F. TURNER, Chairman
M. W. BROWN, Secretary
3049

Town and Country Planning Act 1961

ALBURY-WODONGA DEVELOPMENT CORPORATION
NOTICE OF A PROPOSED AMENDMENT TO THE ALBURY-WODONGA (VICTORIA) INTERIM DEVELOPMENT ORDER 1980, WEST WODONGA

Amendment No. 4

Notice is hereby given that the Albury-Wodonga Development Corporation in pursuance of its powers under the *Town and Country Planning Act 1961* has prepared an amendment to the Albury-Wodonga (Victoria) Interim Development Order 1980, West Wodonga.

The purpose of the amendment is to change the provisions of the order relating to the siting of buildings adjacent to roads in the rural "A" zone so that the Corporation can now exercise discretion regarding the siting of such buildings.

A copy of the amendment has been deposited at the offices of the Albury-Wodonga Development Corporation, Hume Highway, Wodonga, and the Council of the Rural City of Wodonga, Hovell Street, Wodonga, the regional office of the Department of Planning, Jack Hore Place, Wodonga, and at the office of the Department of Planning, 235 Queen Street, Melbourne, and will be open for inspection during office hours by any person free of charge.

Any persons affected by the amendment are required to set forth in writing any submissions they wish to make with respect to the amendment addressed to the Chief Administrative Officer, Albury-Wodonga Development Corporation, Post Office Box 913, Albury, N.S.W. 2640, by 6 November 1982 and to state whether they wish to be heard in respect of their submissions.

30 September 1982

G. R. ANDREW, Chief Administrative Officer, Albury-Wodonga Development Corporation 3041

Town and Country Planning Act 1961

ALBURY-WODONGA DEVELOPMENT CORPORATION
NOTICE OF A PROPOSED AMENDMENT TO THE ALBURY-WODONGA (VICTORIA) INTERIM DEVELOPMENT ORDER 1980, BARANDUDA TOWNSHIP
Amendment No. 3

Notice is hereby given that the Albury-Wodonga Development Corporation in pursuance of its powers under the *Town and Country Planning Act 1961* has prepared an amendment to the Albury-Wodonga (Victoria) Interim Development Order 1980, Baranduda Township.

The purpose of the amendment is to change the provisions of the order relating to the siting of buildings adjacent to roads in the rural "A" and rural "B" zones so that the Corporation can now exercise discretion regarding the siting of such buildings.

A copy of the amendment has been deposited at the offices of the Albury-Wodonga Development Corporation, Hume Highway, Wodonga, and the Council of the Rural City of Wodonga, Hovell Street, Wodonga, the Regional Office of the Department of Planning, Jack Hore Place, Wodonga, and at the office of the Department of Planning, 235 Queen Street, Melbourne, and will be open for inspection during office hours by any person free of charge.

Any persons affected by the amendment are required to set forth in writing any submissions they wish to make with respect to the amendment, addressed to the Chief Administrative Officer, Albury-Wodonga Development Corporation, Post Office Box 913, Albury, N.S.W. 2640, by 6 November 1982 and to state whether they wish to be heard in respect of their submissions.

30 September 1982

G. R. ANDREW, Chief Administrative Officer, Albury-Wodonga Development Corporation 3040

Notice is hereby given that the Geelong Regional Commission has applied for a lease pursuant to Section 134 of the *Land Act 1958* for a term of 99 years in respect of Allotment 1b of Section 5 in the Parish of Moolap for commercial and industrial purposes (Geelong 57/134).

G. R. COWLING, Secretary, Geelong Regional Commission 2785

Notice is given that Jack Whitehead Powling has retired from the partnership of J. W. Powling & Co., Solicitors, of 6-8 Princes Street, Port Fairy from 1 October 1982. Mr Powling will remain with the firm as a consultant. 3050

ELTHAM MINT PTY. LTD. (IN LIQUIDATION)

Notice is hereby given of the Meeting of Shareholders of the above company at the end of Liquidation. The meeting will be held on Wednesday, 10 November 1982 at 10.00 a.m. at 10 Terrara Court, Montmorency.

By order of the Liquidator

S. A. WHITING, 10 Terrara Court, Montmorency, 3094.
Telephone 435 2766 3057

Form 92

The Companies Act 1961, Section 272 (1)
Companies Regulations

SERJAY PTY. LIMITED (IN LIQUIDATION)

NOTICE OF MEETING OF CREDITORS AND CONTRIBUTORIES

Notice is hereby given that a final meeting of the creditors and contributories of Serjay Pty. Limited (in Liquidation) will be held at Top Floor, 460 Bourke Street, Melbourne on 8 November 1982 at 3.45 p.m.

Agenda

To receive the liquidator's account of his acts and dealings and of the conduct of the winding up and of hearing any explanations thereof.

Dated 30 September 1982

3071 JOHN M. SPARK, Liquidator

Form 92

The Companies Act 1961, Section 272

Companies Regulations

FELIX INVESTMENTS PTY. LTD. (IN LIQUIDATION)

NOTICE OF FINAL MEETING OF MEMBERS AND CONTRIBUTORIES

Notice is hereby given that pursuant to Section 272 (2) of the Companies Act 1961, a final meeting of the Company will be held at the offices of Orr, Martin & Waters, Chartered Accountants, Top Floor, 460 Bourke Street, Melbourne, on 8 November 1982 at 3.00 p.m. for the purpose of laying before the meeting an account showing how the winding up has been conducted and the property of the Company has been disposed of and giving any explanation thereof.

Dated 30 September 1982

JOHN M. SPARK, Liquidator

Orr, Martin & Waters, chartered accountants, 460 Bourke Street, Melbourne. 3000. Telephone No. 602 1644

3072

In the Supreme Court of Victoria—1982 Co. No. 12768—
In the matter of the Companies (Victoria) Code; and in the matter of SEA-AIR IMPEX TRADING PTY. LTD.

Notice is hereby given that a Petition for the winding-up of the abovenamed company by the Supreme Court was on Tuesday, 21 September 1982 presented by Chem-Implex Pty. Ltd. (in Liquidation) and that the Petition is directed to be heard before the Court sitting in the Practice Court, Law Courts, William Street, Melbourne at the hour of 10.30 a.m. on Thursday, 28 October 1982 and any creditor or contributory of the said company desiring to support or oppose the making of an order on the Petition may appear at the time of hearing by himself or his Counsel for that purpose; and a copy of the Petition will be furnished to any creditor or contributory of the said company requiring the same by the undersigned on payment of the regulated charge for the same.

The Petitioner's address is 10th Floor, 379 Collins Street, Melbourne in the State of Victoria.

The Petitioner's Solicitor is Philip E. Fox, Esq., of 23rd Floor, 367 Collins Street, Melbourne.

NOTE—Any person who intends to appear on the hearing of the said Petition must serve on or send by post to the abovenamed Solicitor notice in writing of his intention so to do. The notice must state the name and address of the person or if a firm the name and address of the firm and must be signed by the person or firm or his or their Solicitor (if any) and must be served or if posted must be sent by post in sufficient time to reach the abovenamed Solicitor no later than 4 o'clock in the afternoon of Wednesday, 27 October 1982.

3074

In the Supreme Court of Victoria—1982 Co. No. 12751—
In the matter of the Companies (Victoria) Code 1982; and in the matter of MALINEX PTY. LTD.

Notice is hereby given that a Petition for the winding-up of the abovenamed Company by the Supreme Court was on 14 September 1982 presented by Collian Holdings Pty. Limited and that the said Petition is directed to be heard before the Court sitting at the Law Courts, Lonsdale Street, Melbourne at the hour of 10.30 o'clock in the forenoon on 21 October 1982 and any creditor or contributory of the said Company desiring to support or oppose the making of an Order on the said Petition may appear at the time of hearing by himself or his Counsel for that purpose and a copy of the Petition will be furnished to any creditor or contributory of the said Company requiring the same by the undersigned on payment of the regulated charge for the same.

The Petitioner's address is care of Messrs Collie Knott & Co., Solicitors of 35th Level, 459 Collins Street, Melbourne.

The Petitioner's Solicitors are Messrs Madgwicks of 440 Collins Street, Melbourne Victoria.

MESSRS MADGWICKS, solicitors for the petitioner

NOTE—Any person who intends to appear on the hearing of the said Petition must serve on or send by post to the abovenamed Solicitors, notice in writing of his intention so to do. The Notice must state the name and address of the person, or if a firm and must be signed by the person or firm or his or their Solicitor (if any) and must be served, or if posted, must be sent by post in sufficient time to reach the abovenamed not later than four o'clock in the afternoon of 20 October 1982.

MADGWICKS, solicitors, of 440 Collins Street, Melbourne 3075

Companies (Victoria) Code

DURAS JAN PTY. LTD.

Notice is hereby given that a Petition for the winding up of the above Company by the Supreme Court was on 22 September 1982 presented by S. La Spina, A. La Spina and Omega Shoes Pty. Ltd.

And that the said Petition is directed to be heard before the Court sitting at Melbourne at the hour of 10.30 o'clock in the forenoon on Thursday 28 October 1982 and any creditor or contributory of the Company desiring to support or oppose the making of an Order on the said Petition may appear at the time of hearing by himself or his Counsel for that purpose and a copy of the Petition will be furnished to any creditor or contributory of the said Company requiring the same by the undersigned on payment of the regulated charge for the same.

The Petitioner's address is 2 Bedford Street, Collingwood.

The Petitioner's solicitors are Messrs Remington & Co., of 2nd Floor, 60 Albert Road, South Melbourne.

NOTE—Any person who intends to appear on the hearing of the said Petition must serve on or send by post to the abovenamed solicitors a Notice in writing of this intention so to do. The Notice must state the name and address of the firm and must be signed by the person or firm or his or their solicitor (if any) and must be served or if posted must be sent by post in sufficient time to reach the abovenamed not later than 4 o'clock in the afternoon on 27 October 1982.

3032

Companies (Victoria) Code, Section 411 (1) (2)

PAXPAN PTY. LIMITED (IN LIQUIDATION)

NOTICE OF FINAL MEETING OF MEMBERS

Notice is hereby given that in pursuance of section 411 (1) (2) of the Companies (Victoria) Code the Final Meeting of the Members of the abovenamed Company will be held at the offices of Smith, Taggart & Co., Chartered Accountants, 1st Floor, 350 Hampton Street, Hampton, on 8 November 1982 at 10.00 a.m.

The object of the meeting is to receive an account made up by the Liquidator showing how the winding up has been conducted and the property of the Company has been disposed of, and to receive any explanation required thereof.

Dated 4 October 1982

O. KRAWCZUK, Liquidator

Smith, Taggart & Co., chartered accountants, 350 Hampton Street, Hampton, 3188

3110

In the matter of the Companies Act 1961; and in the matter of LAYFORD PTY. LIMITED (in Liquidation)—Notice of Final Meeting of Members

Notice is hereby given pursuant to section 272 of the Companies Act 1961 that the final meeting of the Members of the abovenamed company will be held at 6th Floor, 461 Bourke Street, Melbourne on 8 November 1982 at 9.15 a.m. for the purpose of having an account laid before them showing the manner in which the winding up has been conducted and the property of the company disposed of and of hearing any explanation that may be given by the Liquidator, and also resolving the manner in which the books, accounts and documents of the company and of the Liquidator thereof shall be disposed of.

Dated 29 September 1982

M. I. WANSLEY, Liquidator

Care of Deloitte Haskins & Sells, chartered accountants, 461 Bourke Street, Melbourne, Vic. 3000

3134

In the matter of the Companies Act 1961; and in the matter of LACONIA (VICTORIA) PTY. LIMITED (in Liquidation)—Notice of Final Meeting of Members

Notice is hereby given pursuant to section 272 of the Companies Act 1961 that the final meeting of the members of the abovenamed company will be held at 6th Floor, 461 Bourke Street, Melbourne on 8 November 1982 at 9.30 a.m. for the purpose of having an account laid before them showing the manner in which the winding up has been conducted and the property of the company disposed of and of hearing any explanation that may be given by the Liquidator, and also resolving the manner in which the books, accounts and documents of the company and of the Liquidator thereof shall be disposed of.

Dated 29 September 1982

M. I. WANSLEY, Liquidator

Care of Deloitte Haskins & Sells, chartered accountants,
461 Bourke Street, Melbourne, Vic. 3000 3135

In the Supreme Court of Victoria—No. Co. 12746—In the matter of the Companies (Victoria) Code; and in the matter of GATTRANS PTY. LTD.

Notice is hereby given that a petition for the winding up of the abovenamed company by the Supreme Court, was on 10 September 1982 presented by Golden Fleece Petroleum Limited who carries on business at 500 Collins Street, Melbourne in the State of Victoria and that the said petition is directed to be heard before the Court sitting at Melbourne at the hour of 10.30 o'clock in the forenoon on 21 October 1982 and any creditor or contributory of the said company desiring to support or oppose the making of an order on the said petition may appear at the time of hearing by himself or his Counsel for that purpose; and a copy of the petition will be furnished to any creditor or contributory of the said company requiring the same by the undersigned on payment of the regulated charge for the same.

MESSRS RUSSELL, KENNEDY & COOK, petitioner's solicitors; of 257 Collins Street, Melbourne.

NOTE—Any person who intends to appear on the hearing of the said petition must serve on or send by post to the abovenamed Messrs Russell, Kennedy & Cook notice in writing of his intention so to do. The notice must state the name and address of the person, or, if a firm, the name and address of the firm and must be signed by the person or the firm or his or their Solicitor (if any) and must be served or if posted, must be sent by post in sufficient time to reach the abovenamed no later than 4.00 o'clock in the afternoon of 20 October 1982.

3136

GREENSON TRADERS PTY. LIMITED
MEMBERS' VOLUNTARY LIQUIDATION

Notice is hereby given that an Extraordinary General Meeting of the abovenamed company, duly convened and held at 25 Paul Street, North Ryde in the State of New South Wales, 24 September 1982, the following resolutions were duly passed:

1. That the company be wound up voluntarily.

2. That, pursuant to the resolution for voluntary winding up in accordance with section 396 (1) of the Companies Code, John Desmond Larkins be appointed Liquidator for the purpose of winding up the affairs and distributing the assets of the company, at a remuneration to be fixed.

Dated 13 September 1982

3106

KAYELL STUDIO SUPPLIES PTY. LIMITED (IN LIQUIDATION)

MEMBERS' VOLUNTARY LIQUIDATION

Notice is hereby given that an Extraordinary General Meeting of the abovenamed company, duly convened and held at 25 Paul Street, North Ryde in the State of New South Wales, 24 September 1982, the following resolutions were duly passed:

1. That the company be wound up voluntarily.

2. That, pursuant to the resolution for voluntary winding up in accordance with section 396 (1) of the Companies Code, John Desmond Larkins be appointed Liquidator for the purpose of winding up the affairs and distributing the assets of the company, at a remuneration to be fixed.

Dated 29 September 1982

3107

Companies (Victoria) Code 1982—In the matter of COSMOPOLITAN SHOES PTY. LTD.

Notice is hereby given that at an extraordinary meeting of Members of the abovenamed Company held on 1 October 1982, it was resolved that the Company be wound up voluntarily and at a meeting of creditors held on the same day pursuant to section 398 (1) it was resolved that for such purpose, Barry Keith Taylor and Leigh Christie of B. K. Taylor & Co., 576 St. Kilda Road, Melbourne, be appointed Liquidator.

Notice is also given that after 21 days from this date we shall proceed to distribute the assets. All creditors having any claims against the Company should furnish particulars of same by that date, otherwise we shall proceed to distribute the assets without regard to their claims.

Dated 1 October 1982

B. K. TAYLOR, Liquidator
L. CHRISTIE, Liquidator

B. K. Taylor & Co., public accountants, 576 St. Kilda Road, Melbourne, Vic. 3004. Telephone No.: 529 4422 3108

BORONIA No. 2 CO-OPERATIVE HOUSING SOCIETY
LIMITED (IN LIQUIDATION)

Take notice that the affairs of the above-named Society are now fully wound up and that in pursuance of section 411 (1) of the Companies Act 1981 and of the Co-operative Housing Societies Act 1958, a general meeting of the Society will be held at 146 Sydney Road, Brunswick on 16 November 1982 at 3 p.m. for the purposes of:

(i) Laying before it an account showing how the winding up has been conducted and the property of the Society disposed of and giving any explanations thereof.

(ii) Passing a resolution that the books and papers of the said Society and of the Liquidator relevant to the affairs of the Society be destroyed after a period of twelve months from the date of the meeting.

Dated 6 October 1982

3109

JOHN W. HALSE, Liquidator

The Companies Act 1961

THE LOSS ADJUSTERS INSTITUTE OF VICTORIA (IN MEMBERS' VOLUNTARY LIQUIDATION)

NOTICE CONVENING FINAL MEETING OF THE COMPANY,
PURSUANT TO SECTION 272 (1)

Notice is hereby given that the Final Meeting of Members of the abovenamed Company will be held at the offices of Venn Milner & Terracall, Suite 2, 497 Burke Road, Camberwell on 8 November 1982 at 10.00 a.m. for the purpose of laying before the Meeting an account showing how the winding up has been conducted and the property of the Company has been disposed of and giving any explanation thereof.

Dated 4 October 1982

G. J. SHILTON, Liquidator

Venn Milner & Terracall, chartered accountants, Suite 2, 497 Burke Road, Camberwell, Vic. 3124. Telephone 20 3341 3079

Companies Act 1961, Section 272

PROVO PROPERTIES PTY. LTD. (IN LIQUIDATION)

NOTICE OF FINAL MEETING OF MEMBERS AND CREDITORS

Notice is hereby given that pursuant to section 272 of the Companies Act 1961, the final meeting of the members and creditors of the Company will be held at the offices of Marquand & Co., Mezzanine Floor, 51 Queen Street, Melbourne on Monday, 8 November 1982 at 11.30 a.m. for the purpose of laying before the meeting an account showing how the winding up has been conducted and the property of the Company has been disposed of and of giving any explanation of the account.

Dated 30 September 1982

D. E. TONKIN, Liquidator

Marquand & Co., chartered accountants, 51 Queen Street, Melbourne 3080

Companies Act 1961, Section 272—In the matter of the *Companies Act 1961*; and in the matter of *COSMOS LABORATORIES PTY. LTD. (in Liquidation)*—Notice Convening Final Meeting of Members and Creditors

Notice is hereby given pursuant to section 272 of the Act, that the final meeting of Members and Creditors of the Company will be held at the office of David A. Bradshaw, Public Accountant, 312 Bay Street, Port Melbourne on 5 November 1982 at 10.30 o'clock in the forenoon, for the purpose of the Liquidator laying before the meeting an account of the winding-up and the giving of any explanation thereof.

Dated 1 October 1982

D. BRADSHAW, Liquidator

D. A. Bradshaw, public accountant, 312 Bay Street, Port Melbourne, 3207. Telephone 643103 3081

Form 64

Companies Act 1961, Section 259 (1)
SHARZOOM PTY. LTD. (IN LIQUIDATION)
NOTICE OF MEETING OF CREDITORS

Notice is hereby given that, pursuant to sub-section (1) of section 259 of the *Companies Act 1961*, a Meeting of the creditors of Sharzoom Pty. Ltd. (in Liquidation) will be held at the offices of Wallace, McMullin & Smail, 499 St. Kilda Road, Melbourne, on 21 October 1982 at 10.30 o'clock in the forenoon.

The winding up of the Company commenced on 24 April 1980 and we were appointed Joint and Several Liquidators by Resolution of the Members of the Company. As the Directors declared that the Company would be able to pay its debts in full within a period of twelve months after the commencement of the winding up, the liquidation is proceeding as a Members' Voluntary Winding Up.

I have formed the opinion that the Company will not be able to pay or provide for the payment of its debts in full within that period and this Meeting is summoned in order that the creditors may, if they so wish, exercise their right under sub-section (2) of section 259 of the *Companies Act 1961* to appoint some person other than ourselves to be the Liquidator of the Company for the purpose of winding up the affairs and distributing the assets of the Company.

A Statement of the Assets and Liabilities of the Company will be laid before the Meeting.

Dated 30 September 1982

A. M. HORSBURGH AND J. M. WALSH, Joint Liquidators 3082

In the Supreme Court of Victoria—Co. 12779—In the matter of the *Companies (Victoria) Code*; and in the matter of *K. & K. EXPORT-IMPORT CO. PROPRIETARY LIMITED*

Notice is hereby given that a petition for the winding up of the abovenamed Company by the Supreme Court was on 30 September 1982 presented by Eric John Unger Deputy Commissioner of Taxation of the Commonwealth of Australia and that the said petition is directed to be heard before the Court sitting at the Fifteenth Court, Law Courts, Lonsdale Street, Melbourne at the hour of 10.30 o'clock in the forenoon on 28 October 1982 and any creditor or contributory of the said company desiring to support or oppose the making of an order on the said petition may appear at the time of hearing by himself or his Counsel for the purpose; and a copy of the said petition will be furnished to any creditor or contributory of the said company requiring the same by the undersigned on payment of the regulated charge for the same.

The Petitioner's official address is 350 Collins Street, Melbourne.

The Petitioner's Solicitor is B. J. O'Donovan, Crown Solicitor for the Commonwealth of 99 Queen Street, Melbourne.

B. J. O'DONOVAN

NOTE—Any person who intends to appear on the hearing of the said petition must serve on or send by post to the abovenamed B. J. O'Donovan notice in writing of his intention so to do. The notice must state the name and address of the person, or, if a firm, the name and address of the firm, and must be signed by the person or firm, or his, or their solicitor (if any), and must be served, or, if posted, must be sent by post in sufficient time to reach the abovenamed not later than 4.00 in the afternoon of 27 October 1982. 3076

In the Supreme Court of Victoria—Co. 12781—In the matter of the *Companies (Victoria) Code*; and in the matter of *GATTRANS PTY. LTD.*

Notice is hereby given that a petition for the winding up of the abovenamed Company by the Supreme Court was on 30 September 1982 presented by Eric John Unger Deputy Commissioner of Taxation of the Commonwealth of Australia and that the said petition is directed to be heard before the Court sitting at the Fifteenth Court, Law Courts, Lonsdale Street, Melbourne at the hour of 10.30 o'clock in the forenoon on 28 October 1982 and any creditor or contributory of the said company desiring to support or oppose the making of an order on the said petition may appear at the time of hearing by himself or his Counsel for the purpose; and a copy of the said petition will be furnished to any creditor or contributory of the said company requiring the same by the undersigned on payment of the regulated charge for the same.

The Petitioner's official address is 350 Collins Street, Melbourne.

The Petitioner's Solicitor is B. J. O'Donovan, Crown Solicitor for the Commonwealth of 99 Queen Street, Melbourne.

B. J. O'DONOVAN

NOTE—Any person who intends to appear on the hearing of the said petition must serve on or send by post to the abovenamed B. J. O'Donovan notice in writing of his intention so to do. The notice must state the name and address of the person, or, if a firm, the name and address of the firm, and must be signed by the person or firm, or his, or their solicitor (if any), and must be served, or, if posted, must be sent by post in sufficient time to reach the abovenamed not later than 4.00 in the afternoon of 27 October 1982. 3077

In the Supreme Court of Victoria—Co. 12778—In the matter of the *Companies (Victoria) Code*; and in the matter of *F. T. PRINTING PTY. LTD.*

Notice is hereby given that a petition for the winding up of the abovenamed Company by the Supreme Court was on 30 September 1982 presented by Eric John Unger Deputy Commissioner of Taxation of the Commonwealth of Australia and that the said petition is directed to be heard before the Court sitting at the Fifteenth Court, Law Courts, Lonsdale Street, Melbourne at the hour of 10.30 o'clock in the forenoon on 28 October 1982 and any creditor or contributory of the said company desiring to support or oppose the making of an order on the said petition may appear at the time of hearing by himself or his Counsel for the purpose; and a copy of the said petition will be furnished to any creditor or contributory of the said company requiring the same by the undersigned on payment of the regulated charge for the same.

The Petitioner's official address is 350 Collins Street, Melbourne.

The Petitioner's Solicitor is B. J. O'Donovan, Crown Solicitor for the Commonwealth of 99 Queen Street, Melbourne.

B. J. O'DONOVAN

NOTE—Any person who intends to appear on the hearing of the said petition must serve on or send by post to the abovenamed B. J. O'Donovan notice in writing of his intention so to do. The notice must state the name and address of the person, or, if a firm, the name and address of the firm, and must be signed by the person or firm, or his, or their solicitor (if any), and must be served, or, if posted, must be sent by post in sufficient time to reach the abovenamed not later than 4.00 in the afternoon of 27 October 1982. 3078

In the matter of the *Companies (Victoria) Code*; and in the matter of *DONRAY PTY. LTD.*

Notice is hereby given that at a Meeting of the Members of Donray Pty. Ltd. on 21 September 1982 the following resolution was passed as a Special Resolution:

"That the company be wound up voluntarily and that Mr E. F. McPhail of 689 Whitehorse Road, Mont Albert is hereby appointed Liquidator for the purpose of such winding up."

3051

E. F. McPHAIL, Liquidator

Companies Act 1961, Section 272 (2)
MANJOY PTY. LTD. (IN VOLUNTARY LIQUIDATION)
 NOTICE OF FINAL MEETING

Notice is hereby given that pursuant to section 272 (1) of the *Companies Act 1961*, a general meeting of members of Manjoy Pty. Ltd. will be held at the office of Pannell Kerr Forster, Chartered Accountants, Level 14, 500 Bourke Street, Melbourne on 8 November 1982 at 10.30 a.m.

The purpose of the meeting is to lay accounts before it showing the manner in which the winding up has been conducted and the property of the company has been disposed of and of hearing any explanation that may be given by the Liquidator.
 Dated 1 October 1982

A. T. TUDOR, Liquidator
 I. M. WAVISH, Liquidator
 Pannell Kerr Forster, Level 14, 500 Bourke Street,
 Melbourne 3000 3083

Companies Act 1961, Section 271 (1)
MYLDON PTY. LTD. (IN LIQUIDATION)
 Trading as Geelong Uniform Centre
 NOTICE OF GENERAL MEETING OF MEMBERS AND CREDITORS
 Notice is hereby given that a meeting of members and creditors of Myldon Pty. Ltd. (in Liquidation) will be held at the office of David A. Bradshaw, 312 Bay Street, Port Melbourne, 3207 on Wednesday, 20 October 1982 at 10.00 o'clock in the forenoon.

Agenda

To lay before the meeting an account of the liquidator's costs and dealings and for the liquidator to report on the conduct of the winding-up during the year ended 28 August 1982.

Dated 23 September 1982

DAVID A. BRADSHAW, Liquidator
 David A. Bradshaw, public accountant, 312 Bay Street,
 Port Melbourne, 3207. Telephone: 64 3103 3084

In the Supreme Court of Victoria—Co. 12044—In the matter of the *Companies (Victoria) Code*; and in the matter of IN BLOOM FASHIONS PROPRIETARY LIMITED—
 Notice of Winding Up Order

Winding-up Order made 30 September 1982.

Name and Address of Liquidator: Kenneth James Russell, Coopers & Lybrand, 461 Bourke Street, Melbourne.

B. J. O'DONOVAN, Crown Solicitor for the Commonwealth and solicitor for the petitioner 3087

NUMERO UNO PTY. LTD.

Notice is hereby given that pursuant to section 272 of the *Companies Act 1961* the final meeting of the Creditors and Members of the Company will be held at 2nd Floor, 335 Flinders Lane, Melbourne, on 15 November 1982 at 11.00 a.m. for the purpose of laying before the meeting the account of the winding up and any explanation thereof.

Dated 28 September 1982

DAVID H. ENGLAND, liquidator, 2nd Floor, 335 Flinders Lane, Melbourne, Vic., 3000 3085

Companies Act 1961, Section 272 (1)
AIMS MOTIVATION PTY. LTD. (IN LIQUIDATION)
 NOTICE OF FINAL MEETING

Notice is hereby given that pursuant to section 272 of the *Companies Act 1961*, a general meeting of creditors and members of Aims Motivation Pty. Ltd. will be held at Messrs Peat, Marwick, Mitchell & Co., 16th Floor, 500 Bourke Street, Melbourne on Wednesday, 10 November 1982 at 10.00 a.m. in the forenoon.

The purpose of the meeting is to lay accounts before it showing the manner in which the winding up of the company has been conducted and the property of the company disposed of and of hearing any explanation that may be given by the Liquidator.
 Dated 5 October 1982

J. M. POULTON, Liquidator
 Peat, Marwick, Mitchell & Co., chartered accountants,
 500 Bourke Street, Melbourne, 3000 3086

Companies Act 1961, Section 272
DAYNOR PRESENTATIONS PTY. LIMITED (IN LIQUIDATION)
 NOTICE OF FINAL MEETING

A meeting of the company and the creditors for the purpose of laying before the meeting an account showing how the winding up has been conducted and the property of the company has been disposed of and giving any explanation thereof will be held at the offices of John C. Barnes & Co., 470 Bourke Street, Melbourne, on 11 November 1982 at 11.00 a.m.

J. C. BARNES, Liquidator
 John C. Barnes & Co., 470 Bourke Street, Melbourne,
 3000. Telephone 67 8679 3137

Companies Act 1961, Section 272 (2)
JEFF'S BULK APPLIANCES (HOLDINGS) PTY. LTD.
 (IN LIQUIDATION)
 NOTICE OF FINAL MEETING

Notice is hereby given that pursuant to section 272 (2) of the *Companies Act 1961*, a general meeting of Members of Jeff's Bulk Appliances (Holdings) Pty. Ltd. will be held at Messrs Touche Ross & Co., 10th Floor, 440 Collins Street, Melbourne, on 8 November 1982, at 10.00 o'clock in the forenoon.

The purpose of the meeting is to lay accounts before it, showing the manner in which the winding up has been conducted and the property of the company disposed of, and of hearing any explanation that may be given by the liquidator.

Dated 29 September 1982

G. ARISS, Liquidator
 Messrs Touche Ross & Co., 10th Floor, 440 Collins
 Street, Melbourne, 3000 3138

The Companies Act 1961
BILLAN PTY. LTD. (IN LIQUIDATION)
 NOTICE CONVENING FINAL MEETING OF THE COMPANY,
 PURSUANT TO SECTION 272 (1)

Notice is hereby given that the Final Meeting of Members of the abovenamed Company will be held at the offices of Touche Ross & Co., 440 Collins Street, Melbourne, Victoria, on 14 November 1982 at 10.00 a.m. for the purpose of laying before the Meeting an account showing how the winding up has been conducted and the property of the Company has been disposed of and giving any explanation thereof.

Dated 7 October 1982

R. M. H. COLE, Liquidator
 Touche Ross & Co., chartered accountants, 440 Collins
 Street, Melbourne, 3000 3140

Companies Act 1961, Section 272
HAMILTON (INSURANCES) PTY. LTD. (IN LIQUIDATION)
 NOTICE CONVENING FINAL MEETING OF MEMBERS AND CREDITORS

Notice is hereby given pursuant to section 272 of the *Companies Act 1961* that a General Meeting of the members and creditors of the abovenamed company will be held at the offices of Ferrier Hodgson & Co., 24th Floor, 459 Collins Street, Melbourne, on Monday, 8 November 1982 at 10.00 a.m. for the purpose of having an account laid before them showing the manner in which the winding up has been conducted and the property of the company disposed of and of hearing any explanations that may be given by the Liquidator.

Dated 1 October 1982

A. G. HODGSON, Liquidator
 Ferrier Hodgson & Co., chartered accountants, 459
 Collins Street, Melbourne, 3000 3139

ASSOCIATED TOBACCO COMPANIES CO-OPERATIVE HOUSING SOCIETY No. 9 LIMITED (IN LIQUIDATION)
 SPECIAL RESOLUTION
 Passed 28 September 1982

At a general meeting of the abovenamed Society duly convened and held at W. D. & H. O. Wills (Australia) Limited, 246 East Boundary Road, East Bentleigh, Victoria, on Tuesday 28 September 1982 at 12 noon the subjoined special resolution was duly passed.

1. That the Society having successfully completed its objective 68 months ahead of its expected term be wound up voluntarily, and that Kenneth James Pollard of 246 East Boundary Road, East Bentleigh be appointed liquidator for the purpose of winding up.

2. That the liquidator be empowered to compromise with debtors and/or creditors and/or contributions.

A. S. FISHER, Chairman of Meeting
3052 J. BENTON, Secretary

In the matter of the Co-operative Housing Societies Act 1958 and the Companies Act 1961; and in the matter of ASSOCIATED TOBACCO COMPANIES, CO-OPERATIVE HOUSING SOCIETY No. 9 LIMITED (in Liquidation)—Notice to Creditors

Notice is hereby given that all persons having any claim against the above society are required on or before 9 November 1982 to send their names and addresses and particulars of their debts or claims to Kenneth James Pollard care of W. D. & H. O. Wills (Australia) Limited, 246 East Boundary Road, East Bentleigh, Victoria, the liquidator of the said society, and if so required by notice, in writing, from the said liquidator are personally, or by their solicitors, to come in and prove their said debts for claims at such time and place as shall be specified in such notice; or in default thereof, they shall be excluded from the benefit of any distribution made before such debts or claims are so lodged or proved.

Dated at East Bentleigh, 29 September 1982

3053 K. J. POLLARD, Liquidator

Form 92

Companies Act 1961

AYRESOME PARK HOLDINGS PTY. LTD.
(Formerly Transplant & Breeding Services Pty. Ltd.)
NOTICE OF MEETING OF MEMBERS AND CREDITORS, PURSUANT TO THE COMPANIES REGULATIONS 26 (2) (6) AND 44 (2)

Notice is hereby given that a meeting of creditors of the above-named company will be held at the offices of Messrs Cran Douglas & Co., Chartered Accountants, Floor 9, 128 Exhibition Street, Melbourne 3000 on Monday, 8 November 1982, commencing at 10.00 a.m. the company having convened a meeting of its members for the same day for the purpose of laying before the meeting the Liquidator's accounts showing how the winding up has been conducted and the property has been disposed of for the first twelve months and to give any explanation of the account which may be required.

Dated 1 October 1982

3054 ADRIAN D. CRAN, Liquidator

Registered No. 93700

Companies (Victoria) Code, Section 411 (2)
O.B.C. INTERNATIONAL MARKETING PTY. LTD. (IN LIQUIDATION)

NOTICE CONVENING FINAL MEETING OF MEMBERS AND CREDITORS

Notice is hereby given pursuant of Section 411 (2) of the Companies (Victoria) Code that a meeting of the Members and Creditors of the abovenamed company will be held at the office of Nelson Wheeler, Chartered Accountants, 430 William Street, Melbourne on Wednesday 27 October 1982 at noon, for the purpose of having an account laid before them showing the manner in which the winding up has been conducted and the property of the Company disposed of and of hearing any explanations that may be given by the Liquidator.

Dated 27 September 1982

B. K. SIMMONS, Liquidator

Nelson Wheeler, chartered accountants, 430 William Street, Melbourne, Vic. 3003. Telephone: 329 9955 3055

Form 125

Companies (Victoria) Code

FLETCHER JONES & STAFF (RETAIL) PROPRIETARY LIMITED (IN VOLUNTARY LIQUIDATION)

NOTICE OF MEETING OF CREDITORS, MEMBERS OR CONTRIBUTORIES

Notice is hereby given that a meeting of the members of Fletcher Jones & Staff (Retail) Proprietary Limited (in Voluntary Liquidation) will be held at Warrnambool on 3 November 1982, at 11 o'clock in the forenoon.

Agenda

To produce an account showing how the winding up was conducted and the property disposed of.

Dated 27 September 1982

3056 A. HOOTON, Liquidator

FLORA COLUMBIA PETERSEN, late of Elgar Private Nursing Home, 366 Elgar Road, Box Hill, widow, DECEASED

Creditors, next of kin and others having claims in respect of the estate of the abovenamed deceased who died on 5 August 1982 are required by National Trustees Executors and Agency Company of Australasia Limited of 95 Queen Street Melbourne and Frederick Petersen of 9 Hansen Street Kew the Executors of the Will of the said deceased to send particulars of their claims to the said Executors care of the said Company by 10 December 1982 after which date the Executors will convey or distribute the assets having regard only to the claims of which they then have notice.

RUSSELL, KENNEDY AND COOK, solicitors, 257 Collins Street, Melbourne 3090

ROY MELCHER ANDERSON, late of 4 Corandirk Street, Warneet, retired, DECEASED

Creditors, next of kin and others having claims in respect of the estate of the abovenamed deceased who died on 13 June 1982 are required by James Kenneth Aitken and Nancy Beatrice Dowdle both of 257 Collins Street Melbourne the proving Executors of the Will of the abovenamed deceased to send particulars of their claims to the said Executors care of the undernamed Solicitors by 10 December 1982 after which date they will convey or distribute the assets having regard only to the claims of which they then have notice.

RUSSELL, KENNEDY AND COOK, solicitors, 257 Collins Street, Melbourne 3091

Creditors, next of kin and others having claims in respect of the estate of Jack Gillard Hargreaves late of 35 Market Street Essendon retired deceased who died on 9 July 1982 are to send the particulars of their claims to The Equity Trustees Executors and Agency Company Limited of 472 Bourke Street Melbourne 3000 by 7 December 1982 after which date it will distribute the assets having regard only to the claims of which it then has notice.

RYLAH & RYLAH, solicitors, 191 Queen Street, Melbourne 3092

ETHEL MAY LARKINS, late of "Heatherleigh" Nursing Home, 759 Burwood Road, Hawthorn, widow, DECEASED

Creditors, next of kin and others having claims in respect of the Estate of the Deceased who died on 16 April 1982 are required by the Applicant for grant of Letters of Administration Margaret Ann Boyce of 8 South Daly Street, West Brunswick, Book-keeper, to send particulars to her by 8 December 1982, after which date the Applicant for grant of Administration may convey or distribute the assets having regard only to the claims of which she then has notice.

Dated 6 October 1982

LOUIS S. LAZARUS, 389 Lonsdale Street, Melbourne, proctors for the applicant 3093

GORDON BRIAN YOUNG, late of care of Caltex Road House, Stawell Road, Horsham, labourer, DECEASED

Creditors, next of kin and other persons having claims in respect of the estate of the abovenamed deceased who died on 13 July 1982 are required by the next of kin to send particulars of such claims to the undermentioned Solicitors on or before 15 December 1982, after which date they may convey or distribute the assets having regard only to the claims of which they then have notice.

POWER & BENNETT, solicitors, 12 Pynsent Street, Horsham 3124

MURIEL MARGERY FISHER, late of 70 Murray Street, Anglesea, married woman, DECEASED

Creditors, next of kin and others having claims in respect of the estate of the deceased, who died on 4 June 1982 are required by the Trustee The Union-Fidelity Trustee Company of Australia Limited of 100 Exhibition Street

Melbourne to send particulars to it by 6 December 1982 after which date the Trustee may convey or distribute the assets, having regard only to the claims of which it then has notice.

MESSRS BOWMAN & KNOX, solicitors, 43 Yarra Street, Geelong 3125

WILLIAM TYRWHITT DRAKE, late of "Tonga", Mansfield, in the State of Victoria, grazier, DECEASED

Creditors, next of kin and others having claims in respect of the deceased who died on 24 July 1982 are required by his Trustees Barbara Barclay Constance Tyrwhitt Drake of "Tonga" Mansfield Widow Thomas Michael Rodney Ryan of 9 High Street Mansfield, Solicitor and Colin John Kearley Reynolds of Barwite Agent to send particulars to them care of the undermentioned firm of solicitors by 13 December 1982 after which date the Trustees may convey and distribute the assets having regard only to the claims of which they then have notice.

MAL. RYAN, JACKSON & GLEN, 9 High Street, Mansfield, solicitors for the trustees 3126

EILEEN TERESA KAVANAGH, late of Bodalla Hospital, 32 Walpole Street, Kew, in the State of Victoria, spinster, DECEASED

Creditors, next of kin and others having claims in respect of the estate of the abovenamed deceased who died on 27 June 1982 are required by the National Trustees, Executors and Agency Company of Australasia Limited of 95 Queen Street, Melbourne in the said State the Administrator of the Will and estate of the said deceased to send particulars of their claims to the said Company by 15 December 1982 after which date it will proceed to transfer convey or distribute the assets having regard only to the claims of which it shall then have had notice.

A. B. NATOLI, LL.B., solicitor, of 24 Cotham Road, Kew 3127

KEITH JOHN KEVAN, late of Archibald Crescent, Warragul, cleaner, DECEASED

Creditors, next of kin and others having claims in respect to the estate of the deceased who died on 6 August 1982 are required by the Trustees Alice Jean Johnson and Margery Heather Aurisch to send particulars of their claims to them care of the undersigned Solicitors by 17 December 1982 after which date the Trustees may convey or distribute the assets having regard only to the claims of which they then have notice.

GRAY, FRIEND & LONG, solicitors, Warragul 3128

STELLA PALFREY, late of 629 Riversdale Road, Camberwell, in the State of Victoria, gentlewoman, DECEASED

Creditors, next of kin and others having claims in respect of the Estate of the deceased who died on 18 August 1981 are required by the personal representatives Betty Palfrey Matthews Married Woman and Herbert Norman Matthews Doctor of Dental Science both of 15 Leslie Road, Essendon to send particulars to them care of the undermentioned Solicitor by 8 December 1982 after which date the personal representatives may convey or distribute the assets having regard only to the claims of which they then have notice.

THERESE M. WHITING, solicitor, 2 Second Avenue, East Kew 3033

CATHERINE WALTERS, late of 55 Zetland Road, Mont Albert, retired bank clerk, DECEASED

Creditors, next of kin and others having claims in respect of the estate of the said deceased who died on 16 February 1982 are to send particulars of their claims to The Perpetual Executors and Trustees Association of Australia Limited of 50 Queen Street, Melbourne by 30 November 1982 after which date it will distribute the assets having regard only to the claims of which it then has notice.

LEONARD A. LAWRENCE, 3 Cam Street, East Burwood, 3151, solicitor for the said executor 3034

Creditors, next of kin and others having claims in respect of the estate of Colin Ross Lockwood late of 36 Faithful Street Benalla Carpenter (who died on 6 November 1981) are requested to send particulars of their claims in writing to the undermentioned Solicitors for Mavis June Lockwood the Administratrix by 14 December 1982 after which date the administratrix will distribute the assets having regard only to the claims of which he then has notice.

HAMILTON, CLARKE & BALKIN, solicitors, 81-83 Nunn Street, Benalla 3035

JOSEPH RUEBEN CUMMING, late of 89 Smith Street, Warragul, retired, DECEASED

Creditors, next of kin and others having claims in respect of the estate of the deceased who died on 1 July 1982 are required by the Trustees James Donald Cumming and Marie Cumming to send particulars of their claims to them care of the undersigned Solicitors by 17 December 1982 after which date the Trustees may convey or distribute the assets having regard only to the claims of which they then have notice.

GRAY, FRIEND & LONG, solicitors, Warragul 3129

Creditors, next of kin and others having a claim in respect of the estate Arthur Lambert Andrews late of "Wildwood Park", Wildwood Road, Whittlesea in the State of Victoria, Butcher, now deceased who died on 23 May 1981, the Probate of whose Will has been granted to Ronald Skirrow Andrews of 11 Prospect Grove, Northcote in the said State and Lorraine Patricia Merritt of "Wildwood Park", Wildwood Road, Whittlesea aforesaid are required to send particulars of their claims to the said Executors care of the undermentioned solicitors by 13 December 1982 after which date they will distribute the assets having regard only to the claims of which they then have notice.

LLOYD P. GOODE & CO., solicitors, 406 Lonsdale Street, Melbourne 3130

EDWARD ANTHONY OPALINSKI, late of 21 March Street, Newborough, in the State of Victoria, electrician, DECEASED, intestate

Creditors, next of kin and others having claims in respect of the estate of the deceased (who died on 10 March 1982) are required by the Administratrix Veronica Szeremeta of 32 King Street Moe in the State of Victoria Nurse, the widow of the deceased to send particulars of their claims to her c/- her solicitors Messrs. Littleton Hackford & Malkin of Morwell by 20 December 1982 after which date the said Administratrix will convey or distribute the assets having regard only to the claims of which she has notice.

LITTLETON HACKFORD & MALKIN, solicitors, of 38 Buckley Street, Morwell 3131

ARCHIE HALL CURTIS, formerly of Ultima in the State of Victoria, but late of "Alcheringa", Stewart Street, Swan Hill, in the said State, retired farmer, DECEASED (who died on 13 June 1982)

Creditors, next of kin and all other persons having claims against the Estate of the deceased are required by the Executors of the Will, David Henry Curtis and Mervyn Leonard Curtis, to send particulars to them care of the undersigned on or before 8 December 1982, after which date they will distribute the assets having regard only to the claims of which they then have notice.

GARDEN & GREEN, solicitors, 4 McCallum Street, Swan Hill 3132

OLIVE ELIZABETH BROWN, late of 65 Beaconsfield Parade, Northcote, widow, DECEASED

Creditors, next of kin and others having claims in respect of the estate of the deceased (who died on 4 July 1982) are required to send particulars of their claims to Peter Charles McDonald care of Walsh, Johnston & Co. of 452 High Street, Northcote before 8 December 1982 after which date they will distribute the assets having regard only to the claims of which they then have notice.

WALSH JOHNSTON & CO., solicitors, 452 High Street, Northcote 3133

CHARLES ALLAN JAMES RAMSAY, late of 46 Broomfield Road, Hawthorn East, who died on 16 June 1982

Creditors, next of kin and all others having claims in respect of the said deceased are requested by the Executor Roy Kenneth Ramsay of 31 Dunscombe Avenue, Syndal to send particulars of such claims addressed to the said Executor c/- Ridgeway Clements of 461 Bourke Street, Melbourne aforesaid by 6 December 1982 after which date the said Executor will distribute the assets having regard only to the claims of which he then has notice.

RIDGEWAY CLEMENTS, solicitors, 461 Bourke Street, Melbourne 3141

NELLIE MIRANDA THOM, late of Unit 2, Lot 2, Lime Street, Whittlesea, in the State of Victoria, gentlewoman, DECEASED

Creditors, next of kin and others having claims against the Estate of the deceased who died on 2 August 1982 are to send particulars of their claims to John Hampton Thom c/o Wardlaw Burnes & Co., of 591 Grimshaw Street Bundoora by 29 October 1982 after which date he will distribute the assets having regard only to the claims of which he then has notice.

WARDLAW BURNES & CO., solicitors, 591 Grimshaw Street, Bundoora 3058

Creditors, next of kin and other persons having claims against the estate of John Herbert Williams late of 28 Grattan Street Prahran Retired Railway Employee deceased who died on 10 May 1981 are required to send particulars of their claims to the Executors in care of the undermentioned solicitors by the 7 December 1982 after which date the executors will distribute the assets having regard only for the claims of which they then have had notice.

JAMES P. OGGE & CO. AND E. K. O'DONNELL, solicitors, 4-6 Howitt Street, South Yarra 3059

KAZIMIERZ MNICH, late of 11 Giddings Street, North Geelong, in the State of Victoria, formerly machinist, but late retired machinist, DECEASED

Creditors, next of kin and other persons having claims against the estate of the said deceased who died on 20 August 1982 are required to send particulars of the same to the Executrix Frances Mary Mních in care of the undersigned on or before 6 December 1982 after which date she will distribute the assets having regard only to the claims of which she then has notice.

AINSWORTH & CO., barristers and solicitors, 117 Yarra Street, Geelong 3060

MAURICE ROBERT COSENS, late of Woomelang, in the State of Victoria, farmer, DECEASED

Creditors, next of kin and others having claims in respect of the estate of the abovenamed deceased who died on 9 April 1982 are hereby required by Jessie Valmai Cossens and Richard Murray Cossens the Executors of the Will of the abovenamed deceased to send particulars to the said Executors care of the undermentioned Solicitors by 14 December 1982 after which date they will convey or distribute the assets having regard only to the claims of which they then have notice.

MESSRS OAKLEY THOMPSON & CO., solicitors, 24 Cumming Avenue, Birchip 3483 (and at 205 King Street, Melbourne) 3061

SARAH JANE CAMPBELL, late of Mansfield, spinster, DECEASED

Creditors, next of kin and others having claims in respect of the deceased who died on 21 July 1982 are required by her Trustees Ivy Marjorie Fitzgibbon of Jamieson Road Mansfield Widow and Thomas Michael Rodney Ryan of 9 High Street Mansfield Solicitor to send particulars to them care of the undermentioned firm of Solicitors by 8 December 1982 after which date the Trustees may convey and distribute the assets having regard only to the claims of which they then have notice.

MAL. RYAN, JACKSON & GLEN, 9 High Street, Mansfield 3062

CATHERINE BRIDGET CRAPPER, late of 200 Station Street, Fairfield, married woman, DECEASED

Creditors, next of kin and others having claims in respect of the deceased who died on 19 March 1982 are required by the Trustee Robert Henry Crapper of 200 Station Street Fairfield Grazier to send particulars to him by 10 December 1982 after which date the Trustee may convey or distribute the assets having regard only to the claims of which he then has notice.

MACOBOY, TAYLOR & TAYLOR, solicitors, 32 View Street, Bendigo 3063

ELLEN LILIAN WALSH, formerly of Railway Street, Nathalia, and late of Lily Street, Bendigo, retired school-teacher, DECEASED

Creditors, next of kin and others having claims in respect of the deceased who died 24 February 1982 are required by the Trustees Eileen Veronica Walsh of 2 Railway Street Nathalia Spinster and Winifred Ethel Corcoran of 118

Lily Street Bendigo Widow to send particulars to them by 10 December 1982 after which date the Trustees may convey or distribute the assets having regard only to the claims of which they then have notice.

MACOBOY, TAYLOR & TAYLOR, solicitors, 32 View Street, Bendigo 3064

ALICE HELENA FRANCES KAVANAGH (also known as Alice Eleanor Frances Kavanagh), late of Flat 8, Wesley Court, Seddon Street, Ivanhoe, in the State of Victoria, widow, DECEASED

Creditors, next of kin and other persons having claims against the estate of the abovenamed Deceased are required to send particulars of same to William Charles Ainsworth care of the undersigned on or before 6 December 1982 after which date he will distribute the assets having regard only to the claims of which he then has notice.

AINSWORTH & CO., solicitors, of 117 Yarra Street, Geelong 3065

THOMAS LEO BOWMAN, late of 83 Swanston Street, Terang, retired railway employee, DECEASED

Creditors, next of kin and others having claims in respect of the estate of the abovenamed deceased who died on 2 June 1982 are required by the Executor The Union-Fidelity Trustee Company of Australia Limited to send particulars to it at 100 Exhibition Street, Melbourne by 15 January 1983 after which date the said Company will convey or distribute the assets of the said deceased having regard only to the claims of which the Company shall then have had notice.

DAVID TRICKETT & FRANK GARSIDE, solicitors, 140 High Street, Terang 3066

HOWARD THOMAS ARNOTT, late of 1 Lindsay Street, McKinnon, gentleman, DECEASED

Creditors, next of kin and others having claims in respect of the estate of the abovenamed deceased (who died on 2 July 1982) are required to send particulars of their claims to the executor Graeme Howard Arnott of 11 Diggorra Court, Point Lonsdale, Marine Biologist care of the undermentioned solicitors by 7 December 1982 after which date they may convey or distribute the assets having regard only to the claims of which he then has notice.

AITKEN WALKER & STRACHAN, solicitors, 114 William Street, Melbourne, 3000 3067

Creditors, next of kin and others having claims in respect of the Estate of Patricia May Cooper formerly of 76 Garnsworthy Street, Springvale but late of 38 Arcadia Avenue, The Basin, Widow Deceased who died on 10 August 1982 are to send particulars of their claim to the Executor of the Estate, David Archie Mockett, care of the undermentioned Solicitors by 7 December 1982 after which date he will distribute the assets having regard only to the claims of which he then has notice.

LLOYD P. GOODE & CO., solicitors, 406 Lonsdale Street, Melbourne 3068

Creditors, next of kin and others having claims in respect of the Estate of Thomas Matthew Charles Wilson late of 258 Glenlyon Road, North Fitzroy, Retired Gentleman, Deceased who died on 23 May 1982 are to send particulars of their claim to the Executor and Executrix of the Estate, Leslie Charles Wilson and Joan Marie Alley, care of the undermentioned Solicitors by 7 December 1982, after which date they will distribute the assets having regard only to the claims of which they then have notice.

LLOYD P. GOODE & CO., solicitors, 406 Lonsdale Street, Melbourne 3069

ROSE ELIZABETH WHITING, late of 290 Swansea Road, Lilydale, in the State of Victoria, widow, DECEASED

Creditors, next of kin and others having claims in respect of the Estate of the deceased who died on 2 July 1982 are required by Dorothy May Kitson of 66 Dunblane Road, Noble Park aforesaid, Married Woman the Executrix of the Will of the said deceased to send particulars to her in the care of the undermentioned Solicitors by 15 December 1982 after which date the said Executrix may convey or distribute the assets having regard only to the claims of which she then has notice.

BORCHARD & MOORE, solicitors, of 44 Douglas Street, Noble Park 3070

MARIE DE LANCEY DURNFORD, late of 12 Mores Garden, Cheyne Walk, London, England, DECEASED

Creditors, next of kin and others having claims in respect of the Estate of the abovenamed deceased who died on 25 May 1981 are requested to send particulars thereof to Milan Kantor and David Anthony Lee both of 224 Queen Street, Melbourne, Solicitors, the duly constituted Attorneys of the Executors of the deceased's Will and Two Codicils, on or before 8 December 1982, after which date the Executors will distribute the assets in the Estate having regard only to the claims of which they shall then have had notice.

J. M. SMITH & EMMERTON, solicitors, 224 Queen Street, Melbourne 3073

LESLIE JOHN GORING, late of 87 Manningham Street, Parkville, who died on 2 October 1981

Creditors, next of kin and all others having claims in respect of the said deceased are requested by the Administrator Robert Leslie Goring of 89 Manningham Street Parkville in the State of Victoria to send particulars of such claims addressed to the said Administrator care of Ridgeway Clements, 461 Bourke Street Melbourne by 6 December 1982 after which date the said Administrator will distribute the assets having regard only to the claims of which he then has notice.

RIDGWAY CLEMENTS, solicitors, of 461 Bourke Street, Melbourne 3088

JULIUS FEKETE, late of 48 Fawkner Street, St. Kilda, who died on 27 July 1982

Creditors, next of kin and all others having claims in respect of the said deceased are requested by the Administratrix Eva Millane of 102 Severn Street Box Hill in the State of Victoria to send particulars of such claims addressed to the said Administratrix care of Ridgeway Clements, 461 Bourke Street Melbourne by 6 December 1982 after which date the said Administratrix will distribute the assets having regard only to the claims of which she then has notice.

RIDGWAY CLEMENTS, solicitors, of 461 Bourke Street, Melbourne 3088

Trustee Act 1958

NOTICE TO CLAIMANTS

Pursuant to the *Trustee Act 1958*, creditors next of kin and all other persons having claims in respect of the estate of any deceased person named below are required to send particulars to the legal personal representative or representatives at the addresses stated, after which date the representatives will distribute the assets, having regard only to the claims of which notice has been received:

Jean Catherine Tole, late of 23 Coronation Street, West Footscray, married woman, deceased. Claims to the Executor Eric Noel Tole of 23 Coronation Street, West Footscray by 8 December 1982—JOHN F. CARROLL, solicitor, 4 Paisley Street, Footscray. 3123

In the Supreme Court of the State of Victoria

SALE BY THE SHERIFF

On 25 November 1982 at 2.30 p.m. at the Sheriff's Office, Writs and Warrants Division, 2nd Floor, 241 William Street, Melbourne (unless process be stayed or satisfied).

All the Estate and Interest (if any) of Gerard Szabo of Unit 5, 8 View Road, Springvale as joint proprietor with Diana Szabo of an estate in fee simple in the land described in Certificate of Title Volume 9095 Folio 761 upon which is erected a single-storey housing unit known as Unit 5, 8 View Road, Springvale.

Registered Mortgage No. J.194158 affects the said estate and interest.

Terms—Cash only

3094 R. J. MARTIN, Sheriff's Officer

In the Supreme Court of the State of Victoria

SALE BY THE SHERIFF

On 18 November 1982 at 2.30 p.m. at the Sheriff's Office, Writs and Warrants Division, 2nd Floor, 241 William Street, Melbourne (unless process be stayed or satisfied).

All the Estate and Interest (if any) of John Alfred Pendergast and Sylvia Jean Pendergast (shown on Certificate of Title as Sylvia Jane Pendergast) of 3 Allambi Court, Mt. Eliza as joint proprietors of an estate in fee simple

in the land described in Certificate of Title Volume 8557 Folio 157 upon which is erected a ranch-style home of brick veneer known as No. 3 Allambi Court, Mt. Eliza.

Registered Mortgage Nos. J.229218 and J.862735 affect the said estate and interest.

Terms—Cash only

3095 R. J. MARTIN, Sheriff's Officer

In the Supreme Court of the State of Victoria

SALE BY THE SHERIFF

On 25 November 1982 at 2.30 p.m. at the Sheriff's Office, Writs and Warrants Division, 2nd Floor, 241 William Street, Melbourne (unless process be stayed or satisfied).

All the Estate and interest (if any) of Mercedes Miragaya and Luis Miragaya of 74-76 Johnston Street, Fitzroy as joint proprietors of an estate in fee simple in the lands described in Certificates of Title Volume 9326 Folios 075 and 076 upon which is erected a two-storey brick shop and dwelling (ground floor used as a Restaurant) known as 74-76 Johnston Street, Fitzroy.

Registered Mortgage No. H.696240 affects the said estate and interest of Folio 075 and Mortgage No. J.762911 affects the said estate and interest of Folios 075 and 076.

Terms—Cash only

3096 R. J. MARTIN, Sheriff's Officer

In the Supreme Court of the State of Victoria

SALE BY THE SHERIFF

On 25 November 1982 at 2.30 p.m. at the Sheriff's Office, Writs and Warrants Division, 2nd Floor, 241 William Street, Melbourne (unless process be stayed or satisfied).

All the Estate and Interest (if any) of Les Belchin (shown on Certificate of Title as Leslie Marshall Balchin) of 12 O'Malley Court, Sunbury as proprietor of an estate in fee simple in the land described in Certificate of Title Volume 8891 Folio 389 upon which is erected a double-fronted brown brick residence known as No. 12 O'Malley Court, Sunbury.

Registered Mortgage Nos. D.935496 and E.946539 affect the said estate and interest.

Terms—Cash only

3097 R. J. MARTIN, Sheriff's Officer

In the Supreme Court of the State of Victoria

SALE BY THE SHERIFF

On 24 November 1982 at 12.00 noon at The Police Station, Moe (unless process be stayed or satisfied).

All the Estate and Interest (if any) of Mr L. Anyos (shown on Certificate of Title as Laszlo Anyos) of 21 Ferguson Street, Moe as joint proprietor with Beryl Jean Anyos of an estate in fee simple in the land described in Certificate of Title Volume 8206 Folio 047 upon which is erected a timber dwelling house known as No. 21 Ferguson Street, Moe.

Registered Mortgage No. H.648900 affects the said estate and interest.

Terms—Cash only

3098 J. GREEN, Deputy Sheriff

In the Supreme Court of the State of Victoria

SALE BY THE SHERIFF

On 25 November 1982 at 2.30 p.m. at the Sheriff's Office, Writs and Warrants Division, 2nd Floor, 241 William Street, Melbourne (unless process be stayed or satisfied).

All the Estate and Interest (if any) of Victor R. Longham (shown on Certificate of Title as Victor Robert Ronald Longham) of 21 Ti-Tree Grove, Mornington as joint proprietor with Joan Longham of an estate in fee simple in the land described in Certificate of Title Volume 8552 Folio 652 upon which is erected a dwelling known as No. 21 Ti-Tree Grove, Mornington.

Registered Mortgage Nos. H.724923 and H.767174, and Caveat No. H.885276 affect the said estate and interest.

Terms—Cash only

3099 R. J. MARTIN, Sheriff's Officer

In the Supreme Court of the State of Victoria
SALE BY THE SHERIFF

On 18 November 1982 at 2.30 p.m. at the Sheriff's Office, Writs and Warrants Division, 2nd Floor, 241 William Street, Melbourne (unless process be stayed or satisfied).

All the Estate and Interest (if any) of Maurice Afif and Kay Afif (shown on Certificate of Title as Kolumbia Afif) both of 50 Belmont Road, Ivanhoe as joint proprietors of an estate in fee simple in the land described in Certificate of Title Volume 3714 Folio 772 upon which is erected a brick veneer and brick house known as No. 50 Belmont Road, Ivanhoe.

Registered Mortgage Nos. H.816288 and J.780085 affect the said estate and interest.

Terms—Cash only

3100

R. J. MARTIN, Sheriff's Officer

INSOLVENCY NOTICE

The *Bankruptcy Act 1966*, as Amended, Part X
NOTICE OF ACCEPTANCY OF DEED OF ARRANGEMENT
GORDON LINDSAY JONES
No. 252 OF 1982, PART X

Notice is hereby given that the Deed of Arrangement of the abovenamed debtor(s) has been accepted by a Special Resolution of the creditors passed on 17 September 1982. The Trustee named in the Deed of Arrangement, Clive Henry Morris, of 177 Eley Road, Blackburn South, Victoria 3130.

Dated 4 October 1982

CLIVE HENRY MORRIS, Trustee

Clive Morris & Staff, public accountants, 177 Eley Road, Blackburn South, Vic. 3130. Phone No. 232 3027 3142

**NOTICE OF MAKING OF
STATUTORY RULES
WHICH ARE NOT YET
AVAILABLE**

Notice is given of the making of the following Statutory Rules:

- No. *Magistrates' Courts Act 1971*
321/1982. *Magistrates' Courts (Second Schedule) (Amendment) Rules 1982*
Strata Titles Act 1967
329/1982. *Strata Titles (Registrar's Fees) Regulations 1982*
Supreme Court Act 1958
330/1982. *Supreme Court (Court Fees) Regulations 1982*
Supreme Court Act 1958
331/1982. *Supreme Court (Sheriff's Fees) Regulations 1982*
Transfer of Land Act 1958
332/1982. *Transfer of Land (Fees) Order 1982*
Registration of Births Deaths and Marriages Act 1959
333/1982. *Births Deaths and Marriages (Fees) Regulations 1982*
Public Service Act 1974
337/1982. *Public Service Amendment Regulations (No. 14) 1982*
Marine Act 1958
338/1982. *Marine (Survey, Plans and Compass) Fees (Amendment) Regulations 1982*

- No. *Marine Act 1958*
339/1982. *Marine (Inspection Fees for 'Hire and Drive Yourself' Motor Boats and Rowing Boats) Regulations 1982*
Marine Act 1958
340/1982. *Marine (Examination Fees for Pilot Licences) Regulations 1982*
Marine Act 1958
341/1982. *Marine (Examination Fees for Pilotage Exemption Certificates) Regulations 1982*
Marine Act 1958
342/1982. *Marine (Fees for Examinations and Certificates of Competency) Regulations 1982*
Marine Act 1958
343/1982. *Marine (Fees for Certificates of Service) Regulations 1982*
Valuation of Land Act 1960
344/1982. *Valuation of Land (Supply of Information) Regulations 1982*
Poisons Act 1962
345/1982. *Drugs of Addiction and Restricted Substances (Optometrists) Regulations 1982*
Marketing of Primary Products Act 1958
346/1982. *Onion Marketing Board (Revocation) Regulations 1982*
Marketing of Primary Products Act 1958
347/1982. *Onion Marketing (Polls and Elections) (Eligibility for Enrolment) (Revocation) Regulations 1982*
Vegetation and Vine Diseases Act 1958
348/1982. *Vegetation and Vine Diseases (Fees) Regulations 1982*
Seeds Act 1971
349/1982. *Seeds (Fees) Regulations 1982*
Farm Produce Merchants and Commission Agents Act 1965
350/1982. *Farm Produce Merchants and Commission Agents (Fees) Regulations 1982*
Stock (Artificial Breeding) Act 1962
351/1982. *Stock (Artificial Breeding of Cattle) (Fees) Regulations 1982*
Stock (Artificial Breeding) Act 1962
352/1982. *Stock (Artificial Breeding of Pigs) (Fees) Regulations 1982*
Stock (Artificial Breeding) Act 1962
353/1982. *Stock (Artificial Breeding of Horses) (Fees) Regulations 1982*
Abattoir and Meat Inspection Act 1973
354/1982. *Abattoir and Meat Inspection (Retail Pet Meat Shops) (Fees) Regulations 1982*
Milk and Dairy Supervision Act 1958
355/1982. *Milk and Dairy Supervision (Examination Fees for Certificates) Regulations 1982*
Stock Diseases Act 1968
356/1982. *Stock Diseases (Fees) Regulations 1982*
Abattoir and Meat Inspection Act 1973
357/1982. *Abattoir and Meat Inspection (Knackeries and Pet Food Establishments) (Fees) Regulations 1982*
Protection of Animals Act 1966
358/1982. *Protection of Animals (Fees) Regulations 1982*
Education Service Act 1981
359/1982. *Education Service (Amendment No. 4) Regulations 1982*

NOTICE OF MAKING AND AVAILABILITY OF STATUTORY RULES

In pursuance of the provisions of the *Subordinate Legislation Act 1962* and the Regulations made thereunder notice is given of the making and availability of the following Statutory Rules:

No.	Port of Geelong Authority Act 1958	Price
310/1982.	Port of Geelong (Sundry Amendments) Regulations 1982	20c
	<i>Town and Country Planning Act 1961</i>	
311/1982.	Planning Procedures Regulations 1982	80c
	<i>Abattoir and Meat Inspection Act 1973</i>	
312/1982.	Abattoir and Meat Inspection Regulations 1982	\$1. 80
	<i>Country Fire Authority Act 1958</i>	
313/1982.	Country Fire Authority (Loan No. 173) Regulations 1982	20c
	<i>Port of Melbourne Authority Act 1958 (No. 6312)</i>	
314/1982.	Port of Melbourne Authority (Superannuation) Regulations 1982, Amendment No. 2	20c
	<i>Wildlife Act 1975</i>	
315/1982.	Serendip Wildlife Research Station Regulations 1982	20c
	<i>Poisons Act 1962</i>	
316/1982.	Special Poisons (Prohibition) Regulations 1982	20c
	<i>County Court Act 1958</i>	
317/1982.	County Court (Court Fees) Order 1982	20c
	<i>Evidence Act 1958</i>	
318/1982.	Court Reporting (Fees Amendment) Regulations 1982	20c
	<i>Finance Brokers Act 1969</i>	
319/1982.	Finance Brokers (Licensing and General) (Amendment) Regulations 1982	20c
	<i>Instruments Act 1958</i>	
320/1980.	Instruments (Fees) Regulations 1982	20c
	<i>Money Lenders Act 1958</i>	
322/1982.	Money Lenders (Licence) (Fees Amendment) Regulations 1982	20c
	<i>Police Offences Act 1958</i>	
323/1982.	Police Offences (Fees) Regulations 1982	20c
	<i>Printers and Newspapers Act 1958</i>	
324/1982.	Printers and Newspapers (Fees) Regulations 1982	20c
	<i>Property Law Act 1958</i>	
325/1982.	Property Law (Fees) Regulations 1982	20c
	<i>Religious Successory and Charitable Trusts Act 1958</i>	
326/1982.	Religious Successory and Charitable Trusts Act (Fees) Rules 1982	20c
	<i>Sale of Land Act 1962</i>	
327/1982.	Sale of Land (Fees) Regulations 1982	20c
	<i>Status of Children Act 1974</i>	
328/1982.	Status of Children (Fees) Regulations 1982	20c
	<i>Fisheries Act 1968</i>	
334/1982.	Crayfish Pot (Entitlement, Allocation and Reduction) (Amendment No. 1) Regulations 1982	20c
	<i>Second-hand Dealers Act 1958</i>	
335/1982.	Second-hand Dealers (Exemption No. 6) Regulations 1982	20c

No.	Fuel Prices Regulation Act 1981	Price
336/1982.	Fuel Prices (Declaration of Secrecy) Regulations 1982	20c
	<i>Public Service Act 1974</i>	
PSD189/1982.	Public Service Amendment Determinations (No. 189) 1982	20c
PSD190/1982.	Public Service Amendment Determinations (No. 190) 1982	20c
PSD194/1982.	Public Service Amendment Determinations (No. 194) 1982	20c

Copies of these Statutory Rules are available and may be purchased at the Victorian Government Bookshop, located at 41 St. Andrews Place, East Melbourne (formerly 7A Parliament Place, Melbourne, 3002). If ordered by mail, remittance should be addressed to "The Government Printer, Box 203, North Melbourne, 3051", and should include 50c delivery and handling fee.

The annual subscription rates for Statutory Rules for the year commencing 1 January 1982, payable in advance are as follows:

- *Statutory Rules (other than Public Service Determinations), Pamphlet copies only \$55.00
- Public Service Determinations \$33.00

*The Bound Volume of Statutory Rules is not included in the subscription rate.

F. D. ATKINSON
Government Printer

CONTENTS

	Page
Appointments	3336
Auction Sales Act	3327
Cemeteries—Scale of Fees	3332
Contracts	3330
Estates of Deceased Persons	3333
Government Notices	3312
Insolvency Notice	3389
Lands	3375
Melbourne and Metropolitan Board of Works—Notice	3331
Notice to Mariners	3334
Notice of Making of Statutory Rules	3389
Orders in Council—	
Acts—Country Roads; Crown Land (Reserves); Local Government; Liquor Control; Water; Sewerage Districts; Racing; Soil Conservation; Melbourne and Metropolitan Tramways; Railway Construction and Property Board; Superannuation; Public Service; Community Welfare Services; Country Roads; Parliamentary Committees; River Improvement.	3338 et seq
Police Sale	3323
Private Advertisements	3377
Proclamations	3311
Regulations—	
Act—Police	3319
Resignations	3337
State Rivers and Water Supply Commission	3312
Tenders	3376
Transport Regulation Board—Public Hearings	3328
Waterworks Trust	3323