



Victoria Government Gazette

No. 71—Wednesday, 14 July 1982

PROCLAMATIONS

PUBLIC HOLIDAYS

PROCLAMATION

By His Excellency the Governor of the State of Victoria and its Dependencies in the Commonwealth of Australia, &c., &c., &c.

In pursuance of the provisions contained in Section 71 (2) of the *Public Service Act 1974*, I, the Governor of the State of Victoria, in the Commonwealth of Australia, by and with the advice of the Executive Council of the said State, do by this my Proclamation appoint the days and dates hereunder mentioned to be observed as Public Holidays or Public Half-Holidays (as the case may be) at the places respectively specified, viz.:

Public Holidays

TUESDAY, 2 NOVEMBER 1982, within the Shire of Melvor.

TUESDAY, 2 NOVEMBER 1982, throughout the City of Bendigo.

FRIDAY, 8 OCTOBER 1982, within the Shire of Shepparton.

Public Half-Holidays from the Hour of Twelve o'clock noon

TUESDAY, 31 AUGUST 1982, throughout the North Riding of the Shire of Arapiles.

MONDAY, 11 OCTOBER 1982, throughout the Shire of Birchip.

Given under my Hand and the Seal of the State of Victoria aforesaid, at Melbourne, this sixth day of July in the year of our Lord One thousand nine hundred and eighty-two and in the thirty-first year of the reign of Her Majesty Elizabeth the Second, Queen of Australia.

(L.S.)

B. S. MURRAY

By His Excellency's Command

JOHN CAIN
Premier

GOD SAVE THE QUEEN!

Public Account (Cash Management Account) Act 1982

DATE OF COMING INTO OPERATION

PROCLAMATION

By His Excellency the Governor of the State of Victoria and its Dependencies in the Commonwealth of Australia, &c., &c., &c.

Whereas by an Act of Parliament of the State of Victoria passed in the thirty-first year of the reign of Her Majesty Elizabeth the Second, Queen of Australia, entitled the *Public Account (Cash Management Account) Act 1982*, it is amongst other things enacted that the provisions of the said Act shall come into operation on a day to be fixed by Proclamation of the Governor in Council published in the *Government Gazette*.

Now therefore, I, the Governor of the State of Victoria, by and with the advice of the Executive Council of the said State, do by this Proclamation fix Wednesday, 14 July 1982, as the day on which the provisions of the said Act shall come into operation.

Given under my Hand and the Seal of the State of Victoria aforesaid, at Melbourne, this thirteenth day of July, in the year of our Lord One thousand nine hundred and eighty-two, and in the thirty-first year of the reign of Her Majesty Elizabeth the Second, Queen of Australia.

(L.S.)

B. S. MURRAY

By His Excellency's Command

R. A. JOLLY
Treasurer

GOD SAVE THE QUEEN!

Superannuation (Amendment) Act 1982

DATE OF COMING INTO OPERATION

PROCLAMATION

By His Excellency the Governor of the State of Victoria and its Dependencies in the Commonwealth of Australia, &c., &c., &c.

Whereas by an Act of Parliament of the State of Victoria passed in the thirty-first year of the reign of Her Majesty Elizabeth the Second, Queen of Australia, entitled the *Superannuation (Amendment) Act 1982*, it is amongst other things enacted that the provisions of the said Act shall come into operation on a day to be fixed by Proclamation of the Governor in Council published in the *Government Gazette*.

Now therefore, I, the Governor of the State of Victoria, by and with the advice of the Executive Council of the said State, do by this Proclamation fix Wednesday, 14 July 1982, as the day on which the provisions of the said Act shall come into operation.

Given under my Hand and the Seal of the State of Victoria aforesaid, at Melbourne, this thirteenth day of July, in the year of our Lord One thousand nine hundred and eighty-two, and in the thirty-first year of the reign of Her Majesty Elizabeth the Second, Queen of Australia.

(L.S.)

B. S. MURRAY

By His Excellency's Command

R. A. JOLLY
Treasurer

GOD SAVE THE QUEEN!

Melbourne Corporation (Election of Council) Act 1982,

No. 9763

DATE OF COMING INTO OPERATION OF CERTAIN PROVISIONS

PROCLAMATION

By His Excellency the Governor of the State of Victoria and its Dependencies in the Commonwealth of Australia, &c., &c., &c.

Whereas by an Act of Parliament of the State of Victoria passed in the thirty-first year of the reign of Her Majesty Elizabeth the Second, Queen of Australia, entitled the *Melbourne Corporation (Election of Council) Act, No. 9763*, it is amongst other things enacted that the several provisions of the said Act shall come into operation on the day or the respective days to be fixed by Proclamation or successive Proclamations of the Governor in Council published in the *Government Gazette*.

Now therefore, I, the Governor of the State of Victoria, in the Commonwealth of Australia, by and with the advice of the Executive Council of the said State, do by this my Proclamation fix Tuesday, 13 July 1982, as the day on which sections 1 to 77 inclusive and 78 (1) of the said *Melbourne Corporation (Election of Council) Act, No. 9763*, shall come into operation.

Given under my Hand and the Seal of the State of Victoria aforesaid, at Melbourne, this thirteenth day of July, in the year of our Lord One thousand nine hundred and eighty-two, and in the thirty-first year of the reign of Her Majesty Elizabeth the Second, Queen of Australia.

(L.S.) B. S. MURRAY
By His Excellency's Command
F. N. WILKES
Minister for Local Government
GOD SAVE THE QUEEN!

Land Act 1958
ROAD PROCLAIMED

PROCLAMATION

By His Excellency the Governor of the State of Victoria and its Dependencies in the Commonwealth of Australia, &c., &c., &c.

I, the Governor of the State of Victoria, in the Commonwealth of Australia, by and with the advice of the Executive Council of the said State, pursuant to the provisions of section 25 (3) (c) of the *Land Act 1958*, do hereby proclaim as road the Crown land hereinafter described, viz.:

Parish of Tallygaroopna, being the land indicated by hatching on plan hereunder—(T.234(*) (L.7-788)).

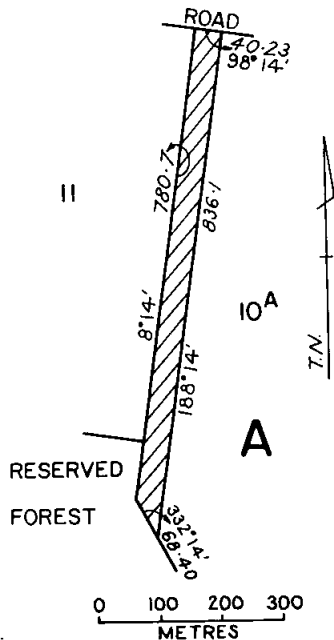

Given under my Hand and the Seal of the State of Victoria aforesaid, at Melbourne, this sixth day of July in the year of our Lord One thousand nine hundred and eighty-two, and in the thirty-first year of the reign of Her Majesty Elizabeth the Second, Queen of Australia.

(L.S.) B. S. MURRAY
By His Excellency's Command
R. A. MACKENZIE
Minister of Lands
GOD SAVE THE QUEEN!

GOVERNMENT NOTICES

PUBLIC TRUSTEE ACT 1958, SECTION 17

Creditors, next of kin and others having claims against the estate of any of the under-mentioned deceased persons are required to send particulars of their claims to the Public Trustee, 168 Exhibition Street, Melbourne, Vic. 3000, the personal representative, on or before 20 September 1982 after which date the Public Trustee may convey or distribute the assets having regard only to the claims of which the Public Trustee then has notice:

ASQUITH, RUPERT FRANCIS ALVERA, late of Ballarat, pensioner, died 23 February 1982.

BATCHELOR, JOHN, late of 11 Willowbank Road, North Fitzroy, retired Melbourne City Council employee, died 9 May 1982.

HILL, MOSES THOMPSON, formerly of 19 Bridgeview Avenue, Cammeray, New South Wales, but late of Royal North Shore Hospital, Sydney, New South Wales, grazier, died 1 September 1942.

STIRZAKER, IRENE SABINA, formerly of 17 Jenkins Street, Reservoir, but late of Caritas Christi Hospice, Kew, widow, died 17 April 1982.

SULLIVAN, ISLA VERONICA, late of Hambleton House, Special Accommodation, 44 St. Vincent Place North, Albert Park, pensioner, died 3 March 1982.

WEST, KEITH HENRY, late of 30 Irvine Crescent, West Brunswick, retired textile worker, died 17 April 1982.

WIKE, RUPERT EDWARD, late of 32 Fyffe Street, Thornbury, pensioner, died 15 February 1982.
Melbourne, 7 July 1982

P. G. DEWAN,
Acting Public Trustee

I hereby give notice that on 28 June 1982 the Public Trustee filed elections to administer the following deceased persons' estates in accordance with section 17 of the *Public Trustee Act 1958*.

ASQUITH, RUPERT FRANCIS ALVERA, late of Ballarat, pensioner, died 23 February 1982.

BATCHELOR, JOHN, late of 11 Willowbank Road, North Fitzroy, retired Melbourne City Council employee, died 9 May 1982.

HILL, MOSES THOMPSON, formerly of 19 Bridgeview Avenue, Cammeray, New South Wales, but late of Royal North Shore Hospital, Sydney, New South Wales, grazier, died 1 September 1942.

STIRZAKER, IRENE SABINA, formerly of 17 Jenkins Street, Reservoir, but late of Caritas Christi Hospice, Kew, widow, died 17 April 1982.

SULLIVAN, ISLA VERONICA, late of Hambleton House, Special Accommodation, 44 St. Vincent Place North, Albert Park, pensioner, died 3 March 1982.

WEST, KEITH HENRY, late of 30 Irvine Crescent, West Brunswick, retired textile worker, died 17 April 1982.

WIKE, RUPERT EDWARD, late of 32 Fyffe Street, Thornbury, pensioner, died 15 February 1982.

P. G. DEWAN,
Acting Public Trustee

168 Exhibition Street, Melbourne, Vic. 3000
7 July 1982

ERRATUM

In *Government Gazette*, No. 61, of 16 June 1982, on page 1978, whereby notice was published of Allowances of His Excellency the Governor, the expression Parish of Tarragul in each case should read Parish of Tarragal.

Private Agents Act 1966

NOTICE OF RECEIPT OF APPLICATIONS FOR LICENCES UNDER THE PROVISIONS OF THE PRIVATE AGENTS ACT 1966

The Clerk(s) of the Magistrates' Court(s) as listed hereunder hereby give notice that applications, as under, have been lodged for hearing by the said Court(s) on the date(s) specified.

Any person desiring to object to any of such applications must—

- (a) lodge with the respective Clerk of the Magistrates' Court a notice in the prescribed form of his objection and of the grounds thereof;
- (b) cause a copy of such notice to be served personally or by post upon the applicant at least three days before the hearing of the application; and
- (c) send or deliver—
 - (i) where the objection is not made by the officer in charge of the police district in which the Court is situated—a copy of the notice to such officer; and
 - (ii) where the objection is not made by the Registrar or Deputy Registrar—a copy to the Registrar.

Full Name of Applicant*	Place of Abode of Applicant or Nominee	Name of Firm or Corporation	Address for Registration	Type of Licence	Date of Hearing
MAGISTRATES' COURT, PRAHRAN					
Clarkson, Henry Ray James	37 Belgrove St, Preston		390 St Kilda Rd, Melbourne	Watchman	23.7.82
Bates, George	15 James St, Ringwood		" "	"	"
Stevens, Graeme Albert	382 Service Rd, Watsonia		" "	"	"
Dooley, James	1A Tannery Cres, Abbotsford		" "	"	"
Johnson, Colin Ray	19 Villawood Ave, Hastings		" "	"	"
Filippo, Rocco	12/44-8 Strettle St, Thornbury		" "	"	"
Bacher, Lou	366 Mt Dandenong Rd, Croydon		" "	"	"
Francis, Sidney Joseph	5 Adelaide St, Murrumbena		" "	"	"
Wellington, Albert Edward	39 Setani Cres, West Heidelberg		" "	"	"

Dated at Prahran 1 July 1982
J. A. GIDLEY, Clerk of the Magistrates' Court

MAGISTRATES' COURT, PRAHRAN					
Gilleece, James Patrick	47 Mt Dandenong Rd, Ringwood East		390 St Kilda Rd, Melbourne	Watchman	
Aminde, Paul	8 Station St, Ferntree Gully		" "	"	
Radke, Phillip Carl	3 Ibsley Crt, St Albans		" "	"	
Ray, John David	97 Peel St, Kew		" "	"	

Dated at Prahran 2 July 1982
J. A. GIDLEY, Clerk of the Magistrates' Court

MAGISTRATES' COURT, FERNTREE GULLY					
Baker, David	7 Alfred St, Upper Ferntree Gully		5 Taylor Rd, Mooroolbark	Watchman	22.7.82

Dated at Lillydale 29 June 1982
D. REES, Clerk of the Magistrates' Court

MAGISTRATES' COURT, FITZROY					
Reeves, Craig	2/103 Barkers Rd, Kew	Roden Security Services Pty. Ltd.	136 Johnston St, Fitzroy	Watchman	26.7.82

Dated at Fitzroy 2 July 1982
G. A. SHARKEY, Clerk of the Magistrates' Court

MAGISTRATES' COURT, GEELONG					
Morgan, Noel Edward	1 Glamis St, Newtown		1 Glamis St, Newtown	Guard Agent	16.7.82

Dated at Geelong 28 June 1982
J. E. REILLY, Clerk of the Magistrates' Court

MAGISTRATES' COURT, HAMILTON					
Mengler, Norman Charles	7 Condon Ct, Hamilton		7 Condon Ct, Hamilton	Inquiry Agent Process Server	22.7.82
" " "	" " "		" "	"	"

Dated at Hamilton 30 June 1982
K. E. CROTTY, Clerk of the Magistrates' Court

* Or in the case of a firm or corporation, of the Nominee

PRIVATE AGENTS—continued

Full Name of Applicant*	Place of Abode of Applicant or Nominee	Name of Firm or Corporation	Address for Registration	Type of Licence	Date of Hearing
MAGISTRATES' COURT, HEIDELBERG					
Morel, Louis Clement Ivens	1/10 Odenwald Rd, Ivanhoe		15 Tarakan St, West Heidelberg	Watchman	26.7.82
Dated at Heidelberg 5 July 1982 E. HACKETT, Clerk of the Magistrates' Court					
MAGISTRATES' COURT, LILYDALE					
Dunn, Frederick Robert	14 Russell St, Mt Evelyn	Excel Security and Investigations Pty. Ltd.	5 Taylor Rd, Mooroolbark	Watchman	5.8.82
Dated at Lilydale 1 July 1982 D. REES, Clerk of the Magistrates' Court					
MAGISTRATES' COURT, MORWELL					
Edbrooke, Guy Nicholas	22 Banksia Cres, Churchill		Lot 2, Toner's La, Morwell	Watchman	4.8.82
Dated at Morwell 2 July 1982 J. S. HUTCHINS, Clerk of the Magistrates' Court					
MAGISTRATES' COURT, PORT MELBOURNE					
Gault, Carol Mary	2 Balmoral Ct, Hallam	Mayne Nickless	390 St Kilda Rd, Melbourne	Watchman	22.7.82
Dated at Port Melbourne 29 June 1982 S. BRYANT, Clerk of the Magistrates' Court					
MAGISTRATES' COURT, SPRINGVALE					
Marsland, Stephen John	23 Wilma Av, Mulgrave	Total Credit Management	11 Wardale Rd, Springvale South	Process Server	23.7.82
" " "	" " "	" "	" "	Inquiry Agent	"
" " "	" " "	" "	" "	Commercial Sub-Agent	"
Dated at Springvale 2 July 1982 K. O'HARE, Clerk of the Magistrates' Court					
MAGISTRATES' COURT, SPRINGVALE					
Wellings, David John	58 Peter St, Springvale South	Total Credit Management	11 Wardale Rd, Springvale South	Commercial Sub-Agent	23.7.82
" " "	" " "	" "	" "	Process Server	"
" " "	" " "	" "	" "	Inquiry Agent	"
Dated at Springvale 29 July 1982 K. O'HARE, Clerk of the Magistrates' Court					
MAGISTRATES' COURT, SUNSHINE					
Hendrikus, Terent	2 Brackley Ct, St Albans	Ian Eddy	146 Ashley St, Maidstone	Watchman	23.7.82
Dated at Sunshine 1 July 1982 J. ISAACS, Clerk of the Magistrates' Court					
MAGISTRATES' COURT, WILLIAMSTOWN					
Cliff, Raymond William	8 Ford St, Newport	R. C. Assessors	8 Ford St, Newport	Inquiry Agent	20.7.82
Dated at Williamstown 29 June 1982 C. RYAN, Clerk of the Magistrates' Court					
MAGISTRATES' COURT, YARRAM					
Prowd, Scott Anthony	Church Rd, Yarram	Wormald Security	340 Abbotsford St, North Melbourne	Watchman	6.8.82
Dated at Yarram 2 July 1982 A. R. TYRES, Clerk of the Magistrates' Court					

* Or in the case of a firm or corporation, of the Nominee

Transport Regulation Act
TRANSPORT REGULATION BOARD

HEARING OF APPLICATIONS

Notice is hereby given that the following applications will be considered by the Transport Regulation Board on 3 August 1982.

BROVA PTY. LTD., Melbourne. Application to licence 10 commercial passenger vehicles with large seating capacities, to operate a stage service between Melbourne and Melbourne Airport, Tullamarine as follows:

Route—Commencing at the company's terminal at 436 Elizabeth Street, City via Elizabeth Street, Flemington Road and Tullamarine Freeway to Melbourne Airport, Tullamarine.

TIME-TABLE

Monday to Sunday

Service to operate between 6.00 a.m. and Midnight with a 15-30 minute frequency.

Fares—Adult Single \$3.50; Child/Pensioner Single \$1.50.

COLLINS & STOTT PTY. LTD., Nowa Nowa. Application to license one commercial passenger vehicle with seating capacity for eight persons, to operate for the carriage of company employees, free of charge, between Bairnsdale and the applicant's sawmill at Nowa Nowa, as and when required.

CROYDON BUS SERVICE PTY. LTD., Croydon. Application to license a required number of commercial passenger vehicles with large seating capacities, to operate as metropolitan stage omnibuses on Route 664 (Croydon-Bayswater-Knox City-Dandenong) as follows: via the existing route to the intersection of Stud Road and Boronia Road, then via Boronia Road, Amesbury Avenue, Harold Street, Templeton Street, Burwood Highway to Knox City Shopping Centre, then via existing route.

TIME-TABLE

Existing time-table as operated, with additional five minutes running time between Knox City and Bayswater.

Fares—To be determined.

This application is subject to the cancellation of existing M.O. licences which authorize operations on Route 664.

DONRIC PTY. LTD., Sunbury. Application to licence one commercial passenger vehicle with seating capacity for 49 persons, to operate as follows: (a) Between Diggers Rest and Sunbury under contract to the Education Department. (b) Under charter conditions from within a 55-km pick-up radius of the G.P.O., Melbourne.

This application is subject to the cancellation of existing charter rights attached to licence T.S.374 at present in the name of the applicant.

FALLON, L. F. & J. P., Alexandra. Application for variation of the conditions of licence T.S.1458, which authorizes an Education Department school contract service between Merton and Alexandra, to operate under charter conditions from within a 20-km pick-up radius of Eildon.

This application is subject to the cancellation of existing charter rights attached to licence T.S.211 at present in the name of the applicant.

FRYDMAN, S., on behalf of the Wanfield Child Care Centre, Hampton. Application to license one commercial passenger vehicle with seating capacity for four persons, to operate for the carriage of children attending the applicant's Child Care Centre between the Centre and local primary schools in Hampton and surrounding areas, as and when required.

HEARD, N. M., Horsham. Application to license one commercial passenger vehicle with seating capacity for eighteen persons, to operate for the carriage of school children between Bungalally and the Haven Primary School under contract to the Education Department. No charter rights are sought in this application.

KIMBER, W. A., Drouin. Application to license a small seating capacity vehicle, to operate as a Country Taxi at Drouin from 40 Young Street, Drouin.

LANGDON'S BUS LINES PTY. LTD., Myrtleford. Application to license one commercial passenger vehicle with seating capacity for 49 persons, to operate as a Country Special Service Omnibus from within a 20-km pick-up radius of Myrtleford. The vehicle to be licensed will hold a 5-star rating for charter purposes.

MANNIX, P. A. & S. F., Merbein. Application for variation of the conditions of licences C.T.5 and C.T.259, which authorize Country Taxi operations from Merbein, to operate as follows: (a) As a taxi service in Irymple within an area bounded by Cowra Avenue, Eleventh Street, Ginquam Avenue and Sixteenth Street. (b) To extend the present area of operation from the corner of Dow Avenue and Flora Avenue along Dow Avenue to Sturt Highway, Walnut Avenue, Nineteenth Street, McCarthys Road and Paschendale Avenue rejoining the present area of operation at the corner of Paschendale Avenue and Sixth Street. (c) As a taxi service between the hours of 11.00 p.m. and 6.00 a.m. within the City of Mildura, including the area bounded by the Murray River and Fourteenth Street, Ontario Avenue, Fifteenth Street and Cowra Avenue through to the Murray River.

VENTURA MOTORS PTY. LTD., South Oakleigh. Application to license one commercial passenger vehicle, with seating capacity for 25 persons, to operate as a metropolitan stage omnibus on the following routes: (a) *Between Knox City Shopping Centre and Burlington Crescent*—Commencing from the Knox City Shopping Centre via Burwood Highway, Templeton Street, Harold Street, Amesbury Avenue, Burlington Crescent, Stokes Road, Amesbury Avenue, Marlemont Avenue, Brentwood Drive, Harold Street, Birchfield Crescent, Alderford Drive, Bladon Street, Stud Road and Burwood Highway to the Knox City Shopping Centre.

TIME-TABLE

Monday to Friday

Depart Burlington Crescent	Arrive Knox City	Depart Knox City	Arrive Burlington Crescent
8.22 a.m.	8.30 a.m.	8.15 a.m.	8.22 a.m.
10.40 a.m.	10.50 a.m.	10.30 a.m.	10.40 a.m.
12 noon	12.10 p.m.	11.50 a.m.	12 noon
2.47 p.m.	2.55 p.m.	—	—
3.35 p.m.	3.45 p.m.	2.40 p.m.	2.47 p.m.
5.05 p.m.	5.15 p.m.	3.25 p.m.	3.35 p.m.
		4.55 p.m.	5.05 p.m.

Fares—1 section ride from Knox City Shopping Centre.

(b) *Between Knox City Shopping Centre and Borg Street*—Commencing from the Knox City Shopping Centre via Burwood Highway, Stud Road, High Street Road, Mowbray Drive, Tintern Crescent, Brennan Drive, Argyle Way, George Street, Berrabri Drive, Taunton Crescent, Borg Street, Ferntree Gully Road, Borg Street, Taunton Crescent, Berrabri Drive, George Street, Argyle Way, Brennan Drive, Tintern Crescent, Mowbray Drive, High Street Road, Stud Road and Burwood Highway to the Knox City Shopping Centre.

TIME-TABLE

Monday to Friday

Depart Borg Street	Arrive Knox City	Depart Knox City	Arrive Borg Street
8.00 a.m.	8.15 a.m.	—	—
8.40 a.m.	9.00 a.m.	8.30 a.m.	8.40 a.m.
9.45 a.m.	10.00 a.m.	9.30 a.m.	9.45 a.m.
11.05 a.m.	11.20 a.m.	10.50 a.m.	11.05 a.m.
2.00 p.m.	2.15 p.m.	1.45 p.m.	2.00 p.m.
4.05 p.m.	4.20 p.m.	3.45 p.m.	4.05 p.m.
		5.50 p.m.	6.05 p.m.

Fares—2 section ride from Knox City Shopping Centre.

(c) *Between Knox City Shopping Centre and Kathryn Road*—Commencing from the Knox City Shopping Centre via Burwood Highway, Riddell Road, Wallace Road, Allister Avenue, O'Connor Road, Laura Road, Kathryn Road, Ferntree Gully Road, Lloyd Street, Anne Street, Kathryn Road, Philip Road, Allister Road, Wallace Road, Riddell Road and Burwood Highway to the Knox City Shopping Centre.

TIME-TABLE

Monday to Friday

Depart Kathryn Road	Arrive Knox City	Depart Knox City	Arrive Kathryn Road
9.10 a.m.	9.30 a.m.	9.00 a.m.	9.10 a.m.
10.15 a.m.	10.30 a.m.	10.00 a.m.	10.15 a.m.
11.35 a.m.	11.50 a.m.	11.20 a.m.	11.35 a.m.
12.25 p.m.	12.40 p.m.	12.10 p.m.	12.25 p.m.
2.25 p.m.	2.40 p.m.	2.15 p.m.	2.25 p.m.
3.10 p.m.	3.25 p.m.	2.55 p.m.	3.10 p.m.
4.40 p.m.	4.55 p.m.	4.20 p.m.	4.40 p.m.
5.30 p.m.	5.45 p.m.	5.15 p.m.	5.30 p.m.

Fares—2 section ride from Knox City Shopping Centre.

No service on Saturday, Sunday or Public Holidays. These services are currently authorized under permit authority.

WARRNAMBOOL BUS LINES PTY. LTD., Warrnambool. Application to license one commercial passenger vehicle with seating capacity for 45 persons, to operate as a Country Special Service Omnibus from within a 20-km radius pick-up of the Warrnambool Post Office. The vehicle to be licensed will hold a 5 star rating for charter purposes.

Application for renewal of licences as shown by the persons listed hereunder to operate under the same terms and conditions.

BENNETT, J. V., M. E., G. V. & M. J., Charlton; C.O.360.

CLYNE'S BUS SERVICE PTY. LTD., Ocean Grove; T.S.609, T.S.688 and T.S.1385.

COWLEY, G. A., Echuca; C.T.332.

GELMAN, A., East St Kilda; S.T.6404.

READ & BRACK PTY. LTD., Benalla; C.T.9, C.T.163, C.T.773, C.T.775 and C.T.776.

RESERVOIR BUS COMPANY (VIC.) PTY. LTD., Reservoir; M.O.325, M.O.336, M.O.390, M.O.392, M.O.393, M.O.411, M.O.428, M.O.500, M.O.521, M.O.549, M.O.555, M.O.579, M.O.582, M.O.583, M.O.585, M.O.586, M.O.590, M.O.652, M.O.664, M.O.667 and M.O.1088.

Notice of any objections should be forwarded to reach the Secretary of the Board not later than 28 July 1982.

Interested parties are advised that it will not be necessary to appear on the hearing date specified, unless advised in writing by the Board.

C. J. V. SMITH
Secretary

Corner Lygon and Princes Streets, Carlton, 3053,
Wednesday, 14 July 1982

Motor Car Act 1958, Section 33

APPROVED LOAD SHARING SUSPENSION SYSTEMS

Notice is hereby given that the following load sharing suspension systems have been approved by the Transport Regulation Board for the purpose of section 33 of the Motor Car Act 1958, provided the load on any one axle in the system does not vary from the nominal proportion of the total load by more than 10 per cent., except where one axle of a tandem group is fitted with four tyres and the other axle is fitted with two tyres in which case the proportion of total load carried on the axle with four tyres shall not exceed 70 per cent. nor be less than 55 per cent.

C. 1 Four spring suspension - short rockers

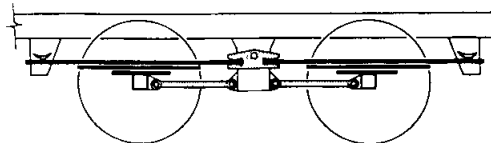
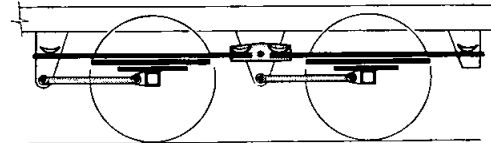

C. 1-2 (Alternative arrangement of radius rods)

C. 2 Four spring suspension - long rockers

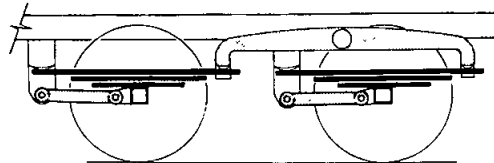

C. 3 Four spring suspension - bellcranks and short pushrods
(Note: Pushrods may be compression struts as shown in diagram or tension rods.)

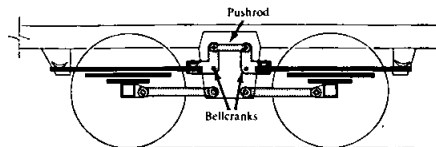

C. 4 Four spring suspension - bellcranks and long pushrods

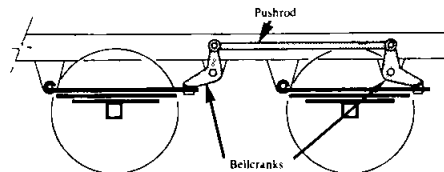

C. 5 Four spring suspension - mechanical hydraulic linkage

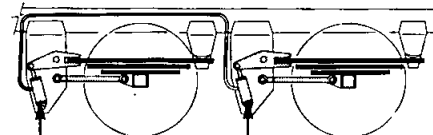

(Interconnected hydraulic cylinders actuated by rockers)

C. 6 Four spring suspension - air levelled

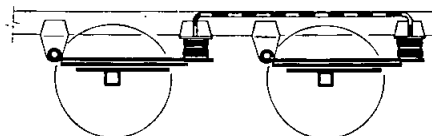

C.7 Single point suspension - 6 rod type
 (Note: Actual number and location of radius rods may vary from example shown.)

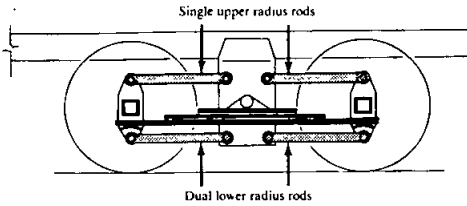

C.8 Single point suspension - upper laminated spring

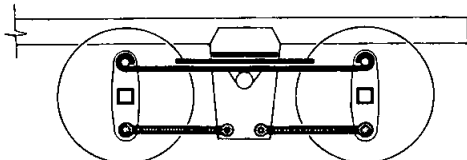

C.9 Single point suspension - lower laminated spring
 (Sometimes called 'camelback' suspension)

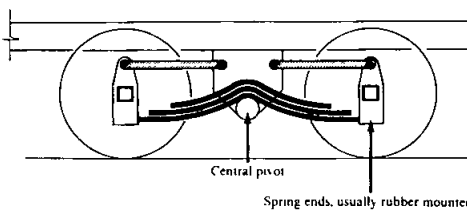

C.10 Single point suspension - dual laminated springs

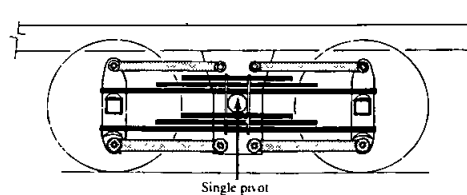

C.11 Parallelogram suspension - dual laminated springs

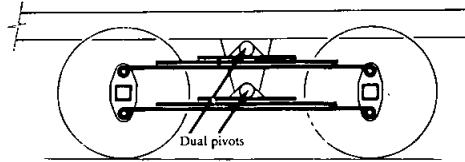

C.12 Walking beam suspension - rigid beam
 (Note: Air or rubber springs may replace the laminated spring shown. Ancillary air dampers are sometimes used.)

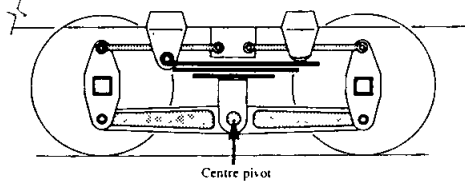

C.13 Walking beam suspension - rigid beam
 (Note: Laminated spring is sometimes supplemented by ancillary air dampers.)

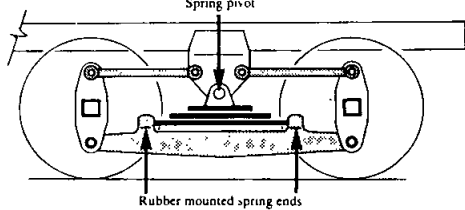

C.14 Walking beam suspension - rigid beam

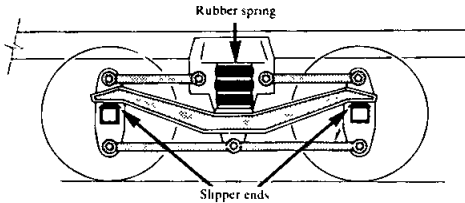

C. 15 Walking beam suspension - rigid beam

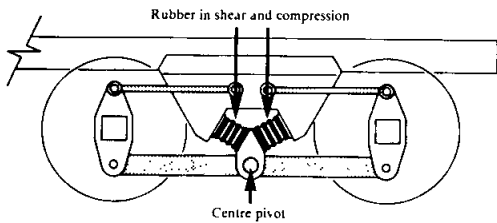

C. 16 Walking beam suspension - articulated beam

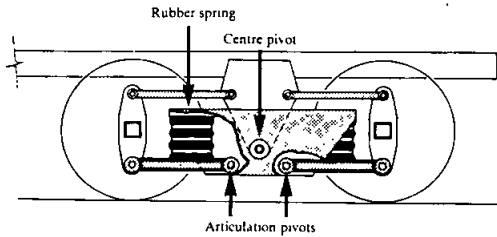

C. 17 Walking beam suspension - articulated beam

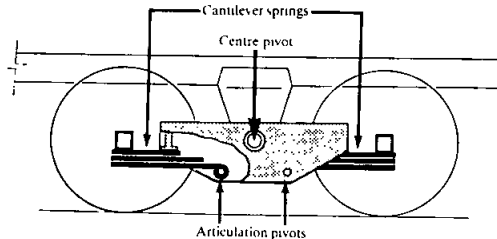

C. 18 Walking beam suspension - articulated beam

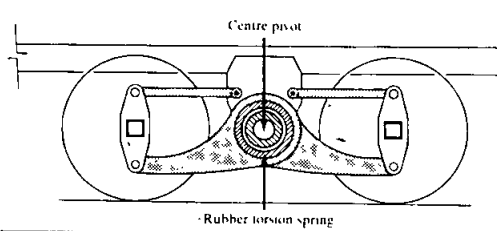

C. 19 Walking beam suspension - flexible beam

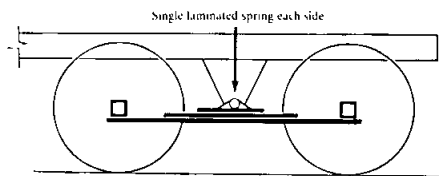

C. 20 Lazy axle - rigid balance beam

(Note: The lazy axle may include a complete axle beam, or each wheel may be mounted on a separate stub axle.)

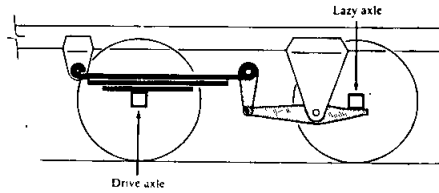

C. 21 Lazy axle - flexible balance beam

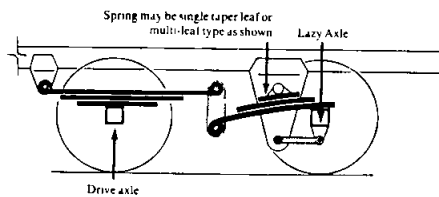

C.23 Torsion bars

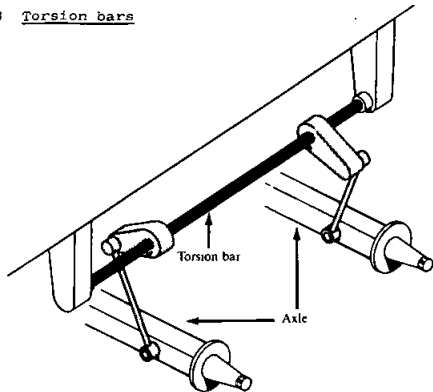

C.24 Air suspension - trailing arms
 (Note: Dual radius rods with single or dual air springs are possible variations. Trailing arms may be either rigid as shown, or in the form of a laminated cantilever spring.)

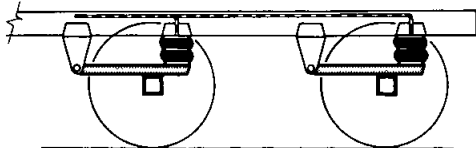

C.25 Air suspension - leading and trailing arms

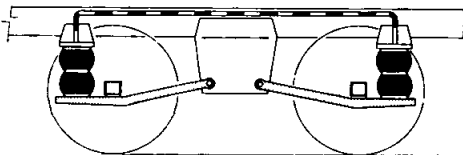

C.26 Air suspension - dual tyred drive axle and single tyred lazy axle
 This suspension system is restricted to passenger coach installations having a dual-tyred drive axle and a single-tyred tag axle and is designed to produce a mass disparity ratio of two-thirds to one-third in favour of the drive axle.

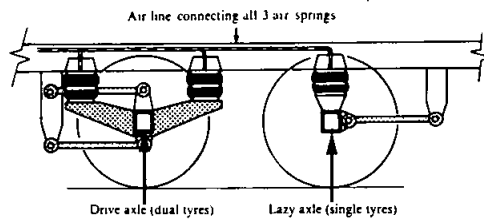

C.27 Four spring suspension - geared bell cranks and pushrods

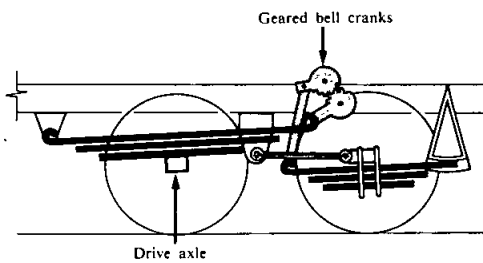

D.1 Laminated springs - short rockers

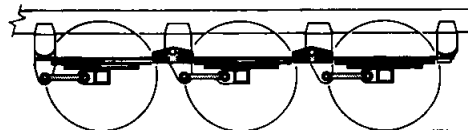

- D.2 Air springs
 (Note: Dual radius rods with single or dual air springs are possible variations. Trailing arms may be either rigid as shown, or in the form of a laminated cantilever spring.)

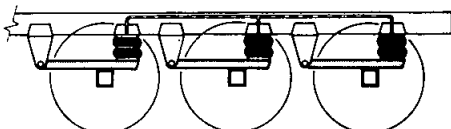

- D.3 Wire rope and springs

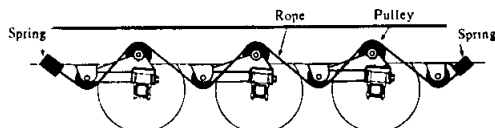

- D.4 Beam and spring suspension

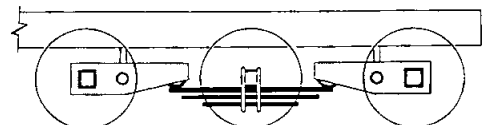

C. J. V. SMITH, Secretary
 Transport Regulation Board

Motor Car Act 1958

APPOINTMENT OF PLACE AS REGISTRATION OFFICE

In pursuance of the powers vested in it by section 5A of the *Motor Car Act 1958* the following place has been appointed as a registration office under the said Act by the Transport Regulation Board—

Transport Regulation Board, Darling Street, Warrnambool, 3280.

Transport Regulation Board, Port Fairy Road, Hamilton, 3300.

Dated 14 July 1982

C. J. V. SMITH
 Secretary

Motor Car Act 1958

CANCELLATION OF APPOINTMENT OF PLACES AS REGISTRATION OFFICES

In pursuance of the powers vested in it by section 5A of the *Motor Car Act 1958* the appointment of the following places as registration offices has been cancelled by the Transport Regulation Board—

Victoria Police, Motor Registration Office, Police Station, corner Raglan Parade and Tylden Street, Dennington, 3280.

Victoria Police, Motor Registration Office, Police Station, Thompson Street, Hamilton, 3300.

Dated 14 July 1982

C. J. V. SMITH
 Secretary

MOTOR CAR ACT 1958, SECTION 19 (1A), (1B) AND (1D)

Notice is hereby given that, for the purposes of section 19 (1A), (1B) and (1D) of the *Motor Car Act 1958*, approval has been granted by the Transport Regulation Board to the associations listed below to organize and conduct official rallies for veteran, vintage, or classic and historic motor cars:

The M.G. Car Club and
 The Mornington Peninsula Historical Vehicles Club.
 C. J. V. SMITH
 Secretary

MOTOR CAR ACT 1958, SECTION 19 (1B) AND (1D)

Notice is hereby given that, for the purposes of section 19 (1B) and (1D) of the *Motor Car Act 1958*, approval has been granted by the Transport Regulation Board to the association listed below to organize and conduct official rallies for vintage or classic and historic motor cars:

The Fire Engine Society of Victoria.
 C. J. V. SMITH
 Secretary

Motor Car Act 1958, Section 33

APPROVED LOAD SHARING SUSPENSION SYSTEMS

Notice is hereby given that the following make and model of load sharing suspension system will not be approved by the Transport Regulation Board for the purposes of section 33 of the *Motor Car Act 1958* if fitted to a vehicle manufactured after Tuesday, 1 June 1982.

Make	Model
Denning	Air-tag

C. J. V. SMITH, Secretary
 Transport Regulation Board

Motor Car Act 1958, Section 33

APPROVED LOAD SHARING SUSPENSION SYSTEMS

Notice is hereby given that the following makes and models of load sharing suspension systems have been approved by the Transport Regulation Board for the purposes of section 33 of the *Motor Car Act 1958*.

Make	Model
Brentwood	BS 1068
Freighter	OAA-25
Tank-Quip	Goth Six Rocker
Vicoach	HC6/HV6

C. J. V. SMITH, Secretary
 Transport Regulation Board

Town and Country Planning Act 1961

CITY OF BENDIGO PLANNING SCHEME

AMENDMENT No. 35

Notice of Approval

In pursuance of the powers conferred by the *Town and Country Planning Act 1961*, the Governor in Council on 6 July 1982, approved a planning scheme entitled the City of Bendigo Planning Scheme Amendment No. 35 in respect of the municipal district of the City of Bendigo, and such Planning Scheme comes into operation on the date this Notice of Approval is published in the *Government Gazette*.

A copy of the Planning Scheme as approved may be inspected free of charge, during office hours, at the office of the Department of Planning, 235 Queen Street, Melbourne, at the office of the City of Bendigo, Lyttleton Terrace, Bendigo, and, when available, at the Office of Titles, Melbourne, and at the Central Plan Office of the Department of Crown Lands and Survey, Melbourne.

J. B. LAWSON
 Acting Secretary

Town and Country Planning Act 1961
GEE LONG REGIONAL PLANNING SCHEME

NOTICE THAT A PLANNING SCHEME (AMENDING) HAS BEEN
 PREPARED AND IS AVAILABLE FOR INSPECTION

Amendment No. 48

Notice is hereby given that the Geelong Regional Commission in pursuance of its powers under the *Town and Country Planning Act 1961*, has prepared an Amendment to the Geelong Regional Planning Scheme for part of the Geelong Region for the purpose of regulating, restricting or prohibiting the use and development of land within the following areas:

Item No. 1—Land fronting the northern side of Ryrie Street, Geelong, west of Union Street and east of Moorabool Street. Proposed zoning change from Public Purposes (Existing)—15—Gas and Fuel Corporation to District Business.

Item No. 2—Land situated on the north-west corner of Malop Street and Yarra Street, Geelong, extending in a northerly direction to Corio Street. Proposed zoning change from Public Purposes (Existing)—22—State Electricity Commission to District Business.

A copy of the Amendment has been deposited at this office—Geelong Regional Commission, State Government Offices, corner of Little Malop and Fenwick Streets, Geelong, at the office of the City of Geelong, Gheringhap Street, Geelong, and at the office of the Department of Planning, 235 Queen Street, Melbourne; and will be open for inspection during office hours by any person, free of charge.

Any persons affected by the Amendment are required to set forth in writing any submissions they may wish to make with respect to the Amendment addressed to the Secretary, Mr G. R. Cowling, Geelong Regional Commission, P.O. Box 770, Geelong, on or before 14 October 1982, and to state whether you wish to be heard in respect of that submission.

G. R. COWLING, Secretary
 Geelong Regional Commission

WESTERNPORT WATERWORKS TRUST

INCREASING THE LIMIT OF BANK OVERDRAFT

His Excellency the Governor of the State of Victoria by and with the advice of the Executive Council thereof has by Order made on 13 July 1982, increased the total amount of the sums which the Westernport Waterworks Trust may owe at any one time in respect of moneys borrowed by overdraft current account pursuant to the provisions of section 288 of the *Water Act 1958*, fixed by the Governor in Council on 23 May 1978, at Two hundred and fifty thousand dollars (\$250 000), to Five hundred thousand dollars (\$500 000).

TOM FORRISTAL
 Clerk of the Executive Council

At the Executive Council Chamber
 Melbourne, 13 July 1982

NHILL SEWERAGE AUTHORITY

INCREASING THE LIMIT OF BANK OVERDRAFT

His Excellency the Governor of the State of Victoria by and with the advice of the Executive Council thereof has by Order made on 13 July 1982, increased the total amount of the sums which the Nhill Sewerage Authority may owe at any one time in respect of moneys borrowed by overdraft of current account pursuant to the provisions of section 79 of the *Sewerage Districts Act 1958*, fixed by the Governor in Council on 19 February 1974, at Twelve thousand dollars (\$12 000), to Seventy thousand dollars (\$70 000).

TOM FORRISTAL
 Clerk of the Executive Council

At the Executive Council Chamber
 Melbourne, 13 July 1982

Melbourne and Metropolitan
BOARD OF WORKS

NOTICE TO THE OWNERS OF TENEMENTS IN THE UNDER-
 MENTIONED STREETS AND THE PRIVATE STREETS, LANES,
 COURTS AND ALLEYS OPENING THERETO

The main pipe in the said streets being laid down, the owners of all tenements situated as under are hereby required on or before 16 August 1982 to cause a proper pipe and stop cocks to be laid so as to supply water within such tenements from the main pipe.

Altona

South Avenue, from Orville Street eastwards 187 metres.
 Edwards Drive, from South Avenue southwards and south-westwards 407 metres.

Lempriere Court, total street from Edwards Drive eastwards.

Roach Drive, from Edwards Drive eastwards 32 metres.
 Davidson Court, from Edwards Drive westwards 40 metres.
 Batman Street, from Edwards Drive south-eastwards 121 metres.

Clement Court, from Batman Street southwards 32 metres.
 Beamish Court, from Edwards Drive north-westwards 25 metres.

Berwick

Clifton Way, from 80 metres east of Grove End Road further eastwards 71 metres.

Mildura Crescent, from Clifton Way southwards 171 metres.
 Eddington Place, total street from Mildura Crescent eastwards.

William Hovell Drive, from John Edgcombe Way eastwards 114 metres.

Bass Place, total street from William Hovell Drive southwards.

Croydon

Beaufort Road, from Edith Avenue westwards 96 metres.
 Narr-Maen Drive, from Bemboka Road to Crossman Drive.
 Crossman Drive, from Narr-Maen Drive south-eastwards 247 metres.

Grose Court, total street from Crossman Drive south-westwards.

Edwina Court, total street from Crossman Drive northwards.

Dandenong

Bonita Court, total street from 133 metres north of McFees Road further northwards, eastwards and westwards.

Doncaster and Templestowe

Santa Rosa Boulevard, from 40 metres southeast of Long Valley Way to Pine Hill Drive.

Carmen Close, total street from Santa Rosa Boulevard north-westwards.

Lisbon Crescent, total street from Santa Rosa Boulevard south-eastwards.

Lyons Place, total street from Pine Hill Drive northwards.

Twyford Way, total street from Pine Hill Drive north-westwards.

Pine Hill Drive, from Springvale Road south-westwards 356 metres.

Powers Street, from 40 metres west of Allara Court to Carbine Street.

Carbine Street, from Powers Street northwards 101 metres.
 Butterfly Gardens, total street from Carbine Street westwards.

Knox

Mockeridge Street, from Argyle Way to Stud Road.

Chappell Drive, from Mockeridge Street north-eastwards 130 metres.

Charlton Court, total street from Chappell Drive south-eastwards.

Argyle Way, from Fewster Drive southwards 309 metres.
 Fewster Drive, from Argyle Way westwards 205 metres.

Landy Court, total street from Fewster Drive southwards.

Lillydale

Helena Road, from Albert Road to Alexandra Road.

Alexandra Road, from South Building Line of Helena Road north-eastwards 44 metres.

Mordialloc

Bond Street, from 56 metres west of De Havilland Road further westwards and northwards 109 metres.

Hinkler Road, from Bond Street northwards 211 metres.

Oakleigh

Spring Valley Drive, from 70 metres southwest of Bellbrook Court to Murchison Crescent.
Murchison Crescent, total street from 88 metres northwest of Spring Valley Drive further westwards and southwards.

Ringwood

Beaufort Road, from Edith Avenue westwards 96 metres.

Sherbrooke

Effie Avenue, from 94 metres west of Glenfern Road further westwards 147 metres.
Brooking Street, from 438 metres northwest of Glenfern Road further north-westwards 78 metres.

Waverley

Woodington Drive, from Whalley Drive westwards 54 metres.
Rata Street, from Whalley Drive southwards and westwards 135 metres.
Unnamed Court, from Rata Street southwards 45 metres.
Whalley Drive, from 20 metres south of Nadia Court further southwards, eastwards, north-eastwards and eastwards including Lots 134 and 135 Whalley Drive 849 metres.
Queens Parade, from Montrose Street to Reid Street.
Atheldene Drive, from Shepherd Street to Tintern Rise.
Tintern Rise, total street from Atheldene Drive north eastwards.
Copnal Court, total street from Atheldene Drive westwards.
Stayner Court, total street from Atheldene Drive south-westwards and westwards.

Werribee

Aurora Court, total street from Parklands Grove westwards, southwards and northwards.
Parklands Grove, from Shaws Road northwards 267 metres.
Olivetree Close, total street from Parklands Grove westwards and northwards.
Woodville Park Drive, from Warringa Crescent north-eastwards 100 metres.
Triholm Avenue, total street from Strezlecki Grove north-westwards.
Gordon Avenue, from Triholm Avenue south-westwards 75 metres.
Evrach Drive, from 50 metres northeast of Kerta Close further north-eastwards 140 metres.
Tillbush Close, from Evrach Drive eastwards 37 metres.

Whittlesea

Greenhill Road, from 80 metres north of Maroondah Terrace further north-eastwards 97 metres.
Virginia Crescent, from Greenhill Road north-eastwards and south-eastwards 127 metres.
Maritana Crescent, from 48 metres southeast of Victoria Drive further south-eastwards, southwards and south-westwards 396 metres.
Gunsynd Close, total street from Maritana Crescent north-westwards.
Flight Court, total street from Maritana Crescent northwards.

6 July 1982

H. G. FORD
Acting Secretary

Cemeteries Act 1958

SCALE OF FEES OF THE KILMORE PUBLIC CEMETERY

In pursuance of the powers conferred upon them by the Cemeteries Act, the trustees of the Kilmore Public Cemetery hereby make the following scale of fees, which shall come into operation upon publication in the *Government Gazette*, and from and after such publication every scale of fees heretofore made by the said trustees shall be and is hereby rescinded to the extent to which it conflicts with this scale.

	\$
Lawn grave, 2.44 m x 1.22 m	100.00
Sinking grave, 1.83 m deep	105.00

A. G. PORTBURY, Trustee
I. B. STILL, Trustee
T. G. CHAPMAN, Trustee

Approved by the Governor in Council, 6 July 1982—
TOM FORRISTAL, Clerk of the Executive Council

Cemeteries Act 1958

SCALE OF FEES OF THE ENSAY PUBLIC CEMETERY

In pursuance of the powers conferred upon them by the Cemeteries Act, the trustees of the Ensay Public Cemetery hereby make the following scale of fees, which shall come into operation upon publication in the *Government Gazette*, and from and after such publication every scale of fees heretofore made by the said trustees shall be and is hereby rescinded to the extent to which it conflicts with this scale.

Public Graves

	\$
Interment in grave without exclusive right— stillborn child	25.00
Interment in grave without exclusive right— others	45.00
Number peg or label	10.00

Private Graves

Land 2.44 m x 1.22 m	70.00
Own selection of land	50.00

Sinking Charges for Private Graves

Sinking grave 1.83 m deep	100.00
Each additional 0.3 m	20.00
Sinking oversize grave (extra)	35.00
Cancellation of order to sink (if commenced)	20.00
Reopening grave (no cover)	100.00
Reopening grave (with cover)	110.00

Miscellaneous Charges

Interment fee	30.00
Interment outside prescribed hours, or on Saturdays, Sundays or Public Holidays or without due notice	40.00
Permission to erect headstone or monument—5 per cent of cost, minimum of \$10.00	

Lawn Cemetery

Lawn grave, 2.44 m x 1.22 m	200.00
Interment fee, including grave sinking	130.00
Bronze plaque supplied by Trust	120.00
Flower container supplied by Trust	20.00

B. K. DUGGAN, Trustee
I. HARMAN, Trustee
S. L. EGAN, Trustee

Approved by the Governor in Council, 6 July 1982—
TOM FORRISTAL, Clerk of the Executive Council

Cemeteries Act 1958

SCALE OF FEES OF THE BOROONDARA PUBLIC CEMETERY

In pursuance of the powers conferred upon them by the Cemeteries Act, the trustees of the Boroondara Public Cemetery hereby make the following scale of fees, which shall come into operation upon publication in the *Government Gazette*, and from and after such publication every scale of fees heretofore made by the said trustees shall be and is hereby rescinded to the extent to which it conflicts with this scale.

Sinking Charges; &c.

	\$
Sinking a private grave (2.13 m)	275.00
Sinking a private grave (2.74 m)	315.00
Reopening any grave or vault	275.00
Exhumation (when authorized)	450.00

Land

Private grave in denominational sections for immediate need	395.00
Private grave in special locations for immediate need	425.00

Miscellaneous Charges

Interment on Saturday morning or Public Holiday (extra)	150.00
Burial in coffin over 2.06 m long or over 0.66 m wide (extra)	125.00
Burial in casket (extra)	125.00
Search of records for one grave	10.00
Right of burial certificate	10.00

<i>Cremated Remains</i>	
	\$
Interment of cremated remains in lawn position	200.00
Interment of cremated remains in grave	100.00
Interment of cremated remains in garden	125.00
Memorial wall niche and plaque	125.00
Reservation memorial wall niche and reservation plaque	150.00
Memorial tree, for 25 years tenure	1500.00
Memorial rose, azalea or shrub for twelve years tenure	250.00
<i>Monumental Fees</i>	
Additional inscription	25.00
Permission to erect or alter monument to value of \$500.00	40.00
Permission to erect or alter monument over value of \$500.00—10 per cent of cost	
<i>Vaults</i>	
Concrete vaults for two burials	1100.00
<i>Annual Grave Maintenance Fees</i>	
(If required by the holder of the right of Burial)	
One grave	35.00
Two graves	45.00
Three graves	55.00

J. F. MAUGHAN, Trustee
 J. B. THOMPSON, Trustee
 H. HALL, Trustee

Approved by the Governor in Council, 6 July 1982—
 TOM FORRISTAL, Clerk of the Executive Council

Cemeteries Act 1958

SCALE OF FEES OF THE BEAUFORT PUBLIC CEMETERY

In pursuance of the powers conferred upon them by the Cemeteries Act, the trustees of the Beaufort Public Cemetery hereby make the following scale of fees, which shall come into operation upon publication in the *Government Gazette*, and from and after such publication every scale of fees heretofore made by the said trustees shall be and is hereby rescinded to the extent to which it conflicts with this scale.

	\$
Land, 2.44 m x 1.22 m	70.00
Sinking grave 1.83 m deep	100.00
Each additional 0.3 m	20.00
Reopening grave (no cover)	100.00
Reopening grave (with cover)	110.00
Interment fee (per burial)	30.00
Permission to erect a headstone or monument	30.00
Exhuming the remains of a body (when authorized)	200.00
Interment of ashes in a private grave	30.00
Memorial wall niche and plaque	100.00

A. WHITING, Trustee
 A. TORNEY, Trustee
 E. K. CROUCH, Trustee

Approved by the Governor in Council, 6 July 1982—
 TOM FORRISTAL, Clerk of the Executive Council

LOCAL GOVERNMENT DEPARTMENT

ORDER CONFIRMED—SHIRE OF LILLYDALE

I, Frank Noel Wilkes, Her Majesty's Minister of the Crown for the time being administering the *Local Government Act 1958*, hereby confirm the Order hereinafter referred to in pursuance of section 514 of the said Act namely:

An Order of the Council of the Shire of Lillydale made on 26 April 1982, directing the compulsory taking of certain land being the land described in Certificate of Title Volume 3034 Folio 702 for road construction purposes.
 Dated 8 July 1982

F. N. WILKES
 Minister for Local Government

Local Government Department
 Melbourne (82/2541)

LOCAL GOVERNMENT DEPARTMENT

ORDER CONFIRMED—CITY OF ARARAT

I, Frank Noel Wilkes, Her Majesty's Minister of the Crown for the time being administering the *Local Government Act 1958*, hereby confirm the Order hereinafter referred to in pursuance of section 514 of the said Act namely:

An Order of the Council of the City of Ararat made on 22 March 1982, directing the compulsory taking of certain land being part of Lot 22 on Plan of Subdivision 110406 and being the land shown by hatching on the plan hereunder for the purpose of providing a place of public resort and recreation.

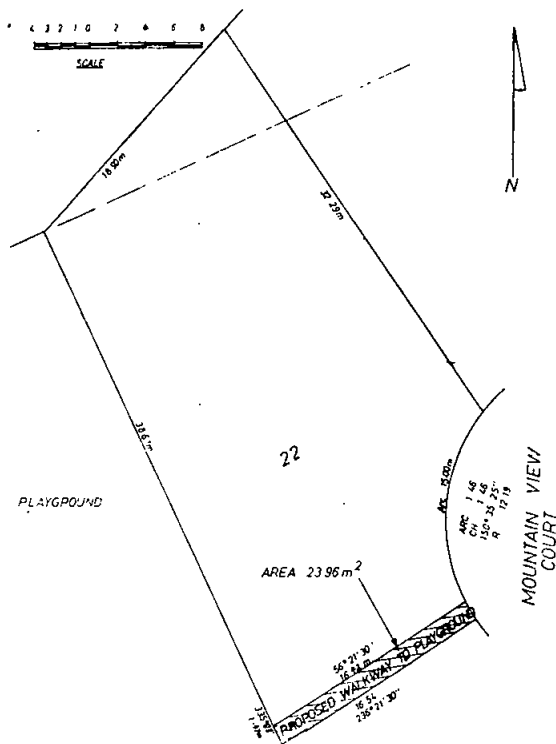

Dated 8 July 1982

F. N. WILKES
 Minister for Local Government

Local Government Department
 Melbourne (81/4036)

Local Government Act 1958

ORDER TO PROHIBIT THE OCCUPATION OR USE OF A BUILDING—60 SWAN STREET, RICHMOND

Whereas it is provided by section 941 of the *Local Government Act 1958* that where any works which are required to be carried out pursuant to the provisions of Division 3 of Part XLIX of the said Act have not been carried out within the time allowed the Minister for Local Government may by Order under his hand published in the *Government Gazette* prohibit the occupation or use of the building by any person and may at any time by Order under his hand published in the *Government Gazette* revoke such Order.

And whereas certain works required to be carried out pursuant to the said Division have not been carried out within the time allowed in respect of the building known as Greyhound Hotel, 60 Swan Street, Richmond.

Now therefore, I Frank Noel Wilkes, Her Majesty's Minister for Local Government for the State of Victoria, do by this Order prohibit the occupation or use of the upper floor of the building, with the exception of a single room being used for office purposes, as and from 14 July 1982.

FRANK WILKES
Minister for Local Government

Local Government Department
Melbourne (82/2835)

Public Records Act 1973

GUIDELINES FOR THE STORAGE OF PUBLIC RECORDS

PUBLIC RECORD OFFICE STANDARD: PROS 82/4

The Public Record Office was established under the *Public Records Act 1973* (as amended) for the better preservation, management and utilization of the public records of Victoria. Public records include any records made or received by a person employed in a public office in the course of his duties. The term "Public Office" is defined in sub-section 2 (1) of the Act to mean—

- (a) any department, branch or office of the Government of Victoria;
- (b) any public statutory body corporate or unincorporate;
- (c) any municipality or other body constituted by or under the *Local Government Act 1958*; and
- (d) any other local governing body corporate or unincorporate.

1. The Keeper of Public Records is obliged by section 12 of the Act to establish Standards for the efficient management of public records and to assist public offices in applying those Standards to records under their control. The officer in charge of a public office is required by section 13 of the Act to cause full and accurate records to be made and kept and is responsible, with the advice and assistance of the Keeper, for carrying out a programme of records management in accordance with the Standards established by the Keeper.

2. Basic specifications for the storage and use of public records have been set out in the publication entitled *Guidelines for the Storage of Public Records*. Many of the matters dealt with in the Standard will require a decision to be made in the context of many variables facing each public office. Much of the text is designed to assist public offices in deciding how best to store and use their records. The Standard is not, therefore, prescriptive throughout. It should be noted, however, that where the Standard is expressed to be prescriptive public offices have an obligation under section 13 of the *Public Records Act 1973* to carry out a programme of records management in accordance with the Standard.

3. In pursuance of section 12 of the *Public Records Act 1973*, I hereby establish those Guidelines as a Standard applying to the records of all public offices referred to in paragraphs (a) and (b) of the definition of "Public Office" in sub-section 2 (1) of the *Public Records Act 1973*. This Standard as varied or amended from time to time shall have effect for a period of 10 years from 30 June 1982 and may be renewed at the expiry of that period.

Date: 29 June 1982

C. HURLEY
Keeper of Public Records

Public Records Act 1973

GUIDELINES FOR THE STORAGE OF PUBLIC RECORDS

PUBLIC RECORD OFFICE STANDARD: PROS 82/4

Variation of Standard

In pursuance of section 12 of the *Public Records Act 1973*, I hereby suspend Public Record Office Standard: PROS 82/4 (Guidelines for the Storage of Public Records) insofar as it relates to the transfer of records to the Public Record Office in respect of—

- (1) public records comprising a collection, catalogue or register of library material maintained by the State Library of Victoria;

- (2) public records comprising a collection, catalogue or register of exhibits maintained by the National Museum of Victoria or the Science Museum of Victoria;
- (3) public records comprising a collection, catalogue or register of works of art maintained by the National Gallery of Victoria; and
- (4) public records in the possession of the La Trobe University.

This variation shall have effect for the period of operation of the Standard and may be renewed at the expiry of the period of operation of the Standard.

Date: 30 June 1982

C. HURLEY
Keeper of Public Records

Labour and Industry Act 1958

ORDER OF EXEMPTION UNDER SECTION 80c

Whereas pursuant to section 80c of the *Labour and Industry Act 1958* as amended by the *Labour and Industry (Further Amendment) Act 1969*, the Council of the Shire of Kerang has applied to the Minister for an order exempting certain shopkeepers of shops in its municipal district from being required to close and keep closed their shops in accordance with Part VI. of the said Act:

Now therefore, I, Robert Allen Jolly, Her Majesty's Minister of Labour and Industry in the State of Victoria, do pursuant to the aforesaid section 80c of the *Labour and Industry Act 1958* make this order granting exemption to—

CYNTHIA and EDNA SCHAUER, Gorton Drive, Lake Kangaroo

in the Shire of Kerang from being required to close and keep their shop on—

Saturdays, 1.00 p.m. to 5.00 p.m.

Sundays and Public Holidays between the hours of 10.00 a.m. and 5.00 p.m.

provided that such exemption shall not apply to Good Friday or Anzac Day.

Dated at Melbourne, 17 June 1982

R. A. JOLLY
Minister of Labour and Industry

Imitation Milk Act 1969

STATE OF VICTORIA

NOTICE

I, Daniel Eric Kent, Minister of Agriculture, hereby give notice that I have specified as a product exempted from the operation of the *Imitation Milk Act 1969* the product known as—

KARIMA NON-DAIRY BEVERAGE WHITENER

subject to the following conditions:

1. The product is manufactured exclusively for export beyond Australia.
2. The Company maintains records of the quantity of the product manufactured and exported, together with its export history and destination beyond Australia.
3. That those records be available at all reasonable times for inspection by an inspector appointed under the *Imitation Milk Act 1969*.

The identification of the product is as follows:

<i>Composition</i>	
Hydrogenated Edible Vegetable Oils	40.5 per cent.
Reducing Sugars	48.7 per cent.
Sodium Caseinate	5.6 per cent.
Potassium Phosphate	1.5 per cent.
Glycerol Monostearate	1.1 per cent.
Lecithin	0.1 per cent.
Sodium Silicoaluminate	0.3 per cent.
Moisture	2.2 per cent.

100.0 per cent.

This product is manufactured by Nestlé Australia Ltd., Henderson Road, Tongala, Victoria, and is a non-dairy beverage whitener.

28 June 1982

D. E. KENT
Minister of Agriculture

CONTRACTS ACCEPTED

AMENDMENTS

Schedule Number	Item Number	New Rate	Effective Date
		\$	
<i>Batteries (Lead Acid Cells)</i>			
1/02	1, 2	*	
*Correction: Melbourne Distribution Points— Delete: 190 Rooks Road, Vermont, 3133 Telephone; 873 1122 Add: P.O. Box 133, West Footscray, 3012 Telephone; 314 3255			
<i>Cleaning and Polishing Requirements</i>			
1/04	39 40, 43-45	*†	5.7.82
*Delete: Minimum order \$300.00 †Delete: J. W. Tomlin Pty. Ltd. Add: Purchase from Education Department			
<i>Hose Sheeting etc.</i>			
1/08	49-50	*	14.7.82
*Delete: Apply Tender Board Add: Purchase Regulation 84			
<i>Protective Clothing, Uniforms, etc.</i>			
1/14	1 2 3 10 12 13 15 16 19	12.89 12.89 12.89 14.53 14.53 13.57 14.23 13.90 0.89	1.7.82
<i>Fasteners</i>			
1/26	31-38 71, 73-74	Sidney Cooke Price List June 1982 Less 28% Sidney Cooke Price List June 1982 Less 28%	2.7.82
<i>Iron (Galvanised)</i>			
1/30	10	*	7.7.82
*Change of Address— Delete: Robot Trading Co. Pty. Ltd., 32-34 Howleys Rd, North Clayton, 3168 Telephone: 543 3322 Add: Robot Trading Co. Pty. Ltd., 326 Ferntree Gully Rd, Notting Hill, 3168 Telephone: 543 3322			
<i>Steel (Mild)</i>			
1/35	3	*	1.7.82
*Correction: Delete: Elders Metals Ltd. List 28.1.82 Less 21% Add: Tubemakers of Australia Ltd. List 28.1.82 Less 21% Trading terms unchanged			
<i>Liquid Petroleum Gas (Bulk and Cylinders)</i>			
1/52A	1 2 3 4 5 6	237.51* 243.42* 261.19* 272.01* 291.65* 18.02*	1.7.82
*Trading terms unchanged			
<i>Motor Spirit, Kerosene, Fuel Oils, etc.</i>			
1/53B	21 23	0.4654 0.4332	1.6.82
*Petrol Outlets: Add: B.P., B.P., Nagambie, 276 High St, Nagambie Trading hours: 7 a.m. to 7 p.m. S/Stn rates			

AMENDMENTS—continued

Schedule Number	Item Number	New Rate	Effective Date
		\$	
<i>Hand Tools (General)</i>			
1/56	339	*	
*Correction: Composition of solder should read 50% Tin 50% Lead			
<i>Provisions—Melbourne and Metropolitan District</i>			
2/01	46 47 48	9.77 19.05 7.24	12.7.82
Correction: Delete: Mum's Chips Company Pty. Ltd., 107-109 Peel St, Port Melbourne, 3051 Add: Mum's Chips Company Pty. Ltd., 107-109 Peel St, North Melbourne, 3051			
J. M. PAWSON, Secretary to the Tender Board			

CONTRACTS ACCEPTED—(Series 1982-83)

PUBLIC WORKS

Drainage works, Grano Street, siteworks, Mental Hospital and Training Centre, Ararat, \$14 387.70—City of Ararat, Ararat.

Extend steamline/lagging of condensate line, Mental Hospital, Beechworth, \$15 769.00—James L. Williams Pty. Ltd., Heidelberg West.

Renovations and alterations, Victorian Government Travel Authority, Brisbane, \$64 058.00—Dear & Flanagan Shopfitters Pty. Ltd., Coorparoo.

Erection of education and community activity centre, Broadmeadows Technical School, No. 7060, \$348 500.00—F. G. Dixon, Reservoir.

External repairs and painting, Chandler High School, No. 7712, \$27 970.00—Goldspink Bros. & Jones Pty. Ltd., Clayton.

Supply of alarms, Education Security Branch, Collingwood, \$32 500.00—Simplex International Time Equipment Pty. Ltd., Carnegie.

Connection to sewer, Croydon Education Centre, \$19 600.00—J. R. & B. L. Kendall, Greensborough.

Erection of multi purpose room canteen and art craft, Delacombe P.S., \$284 023.00—A. W. Nicholson Pty. Ltd. Ballarat.

Installation of fire service, Elwood Primary School, No. 3942, \$15 565.00—G. A. & K. Wright (Plumbers) Pty. Ltd., Mulgrave.

Supply of laundry press, H.M. Training Prison, Geelong, \$11 000.00—Horscroft Engineering Pty. Ltd., Clayton.

Education and Community Activity Centre and Drama Facilities, Greenwood High School (Watsonia), No. 7874, \$519 100.00—H. M. Keast & Sons Pty. Ltd., Burwood.

Home economics and needle craft facilities, Hamilton High School, No. 7885, \$607 111.00—A. W. Nicholson Pty. Ltd., Ballarat.

External repairs and painting, Hampton Primary School, No. 3754, \$52 324.82—I. & M. Stiglic, Endeavour Hills.

Restump section of centre wing, Hightett High School, No. 7915, \$22 900.00—Atlas Reblocking, Noble Park.

Air curtains to laundry, Willsmere Psychiatric Hospital, \$28 269.00—James L. Williams Pty. Ltd., Heidelberg West.

Remodelling of Wards B and C, Psychiatric and Mental Hospital, \$59 504.00—Mattioli Bros. (Aust.) Pty. Ltd., Burwood.

Education and community activity centre and canteen, Macleod Technical School, No. 7220, \$435 071.00—H.C.F. Australia Pty. Ltd., Narre Warren.

Partitioning alterations, 9th level, 168 Exhibition Street (Arts), \$15 118.00—Lecon Modular Finishes (1971) Pty. Ltd., Melbourne.

Refurbishment work to Melbourne Technical College of Hairdressing, \$102 127.00—C. & K. Construction Co. Pty. Ltd., Ivanhoe.

Internal and external renovations, Moe Primary School, \$72 650.00—John Toth & Co., West Sunshine.

Alterations and additions, Monbulk Primary School, No. 3265, \$93 997.00—John Trotter & Son Pty. Ltd., Boronia.

Library conversion and internal cyclic maintenance, Moorabbin Primary School, No. 1111, \$73 628.00—R. Memed, Dandenong.

Asphalt re-sheet, Mooropna Primary School, No. 1432, \$12 180.00—Wilkinson & Brock, Wangaratta.

Construction of new students toilet block and conversion of existing toilet to handicapped persons toilet, Mossfield Primary School, No. 5002, \$83 351.00—R. & S. Developments Pty. Ltd., Riddells Creek.

Cyclic maintenance, Mount Waverley High School, No. 8105, \$41 760.00—R. & M. B. Fredriksson Pty. Ltd., East Doncaster.

Internal and external repairs and painting, Niddrie High School, No. 8165, \$171 930.00—A. C. Krstev, Bundoora.

Beach protection works, Portland Coastline (Ports and Harbors), \$50 000.00—Portland Harbor Trust Commission, Portland.

Supply of 1 x four wheel drive tow vehicle, Port Melbourne, \$31 727.00—International Harvester Aust. Ltd., Brooklyn.

Mini computer installation, Port Melbourne Marine Laboratory, \$148 319.00—Prime Computer of Aust. Ltd., Melbourne.

Middle Park renourishment, South Melbourne Coastline, \$80 450.00—Duncan & Russell (Vic.) Pty. Ltd., Footscray.

Internal and external repairs and painting, Sunshine Heights Primary School, No. 4744, \$47 690.00—S. & A. Burlak, Glenroy.

Internal and external repairs and painting to Junior School, The Basin Primary School, No. 2329, \$46 251.00—Goldspink Bros. & Jones Pty. Ltd., Clayton.

Erection of a new toilet block, Thorpdale Primary School, No. 2966, \$62 426.00—G. A. & K. Wright (Plumbers) Pty. Ltd., Mulgrave.

Installation and collection of sanitary disposal units, 1 April 1982–31 March 1983, \$12 922.40—Wellcome Australia Limited, Northcote.

Staff and administration upgrade, Wangaratta Technical School, No. 7385, \$220 840.00—Southwell Constructions, Wangaratta.

Upgrading of art/craft room and staff improvements, Warracknabeal Primary School, No. 1334, \$38 266.00—J. & G. Panozzo Nominees, Horsham.

Art/craft conversion, Wembley Primary School, No. 4788, \$32 974.00—E. Osinski Building Co., Pty. Ltd., Kingsbury.

Provision of a new covered walk way and alterations, Wendouree Primary School, No. 1813, \$33 336.00—Ian H. McNamara, Creswick.

Werribee—Dredging of river mouth PF005, Werribee Coastline (Ports and Harbors), \$75 465.00—Duncan & Russell (Vic.) Pty. Ltd., Footscray.

Construction of an education and community activity centre, Werribee Technical School, No. 7402, \$389 000.00—Gathercole Industries (Aust.) Pty. Ltd., Richmond.

Library conversion, staff improvements and additional relocatable classroom, Yackandandah Primary School, No. 1103, \$71 783.00—Roy O. Tobias, Wangaratta.

Temporary accommodation, electrical services, Yallourn College of T.A.F.E., \$47 179.00—A.K.C. Electrics Pty. Ltd., Fairfield.

New toilet block, breezeway, covered way and sewerage treatment plant, Yarra Road Primary School, No. 1406, \$97 812.00—P. M. Versteegen & Sons Pty. Ltd., Ringwood.

External repairs and painting/toilet repairs, Yarraman Park Primary School, No. 4807, \$69 998.00—Goldspink Bros. & Jones Pty. Ltd., Clayton.

D. J. LITTLE, Director-General 12.7.82

CONTRACTS ACCEPTED—(Series 1982–83)

PUBLIC WORKS

His Excellency the Governor of the State of Victoria by and with the advice of the Executive Council thereof has by Order made on 6 July 1982 approved of the acceptance by the Minister of Public Works of the under-mentioned offers without public tenders being invited, viz.:

Offer of F. J. Hall for professional services (Architectural) at Mt. Baw Baw Alpine Reserve for the sum of Twelve thousand dollars (\$12 000.00)—(113662/2).

Offer of Talbot Hunt & Partners Pty. Ltd. for professional services (Architectural) at West Meadows Heights Primary School for the sum of Forty-seven thousand dollars (\$47 000.00)—(N.187822p).

Offers at the amounts shown for professional services at Gisborne Technical/High School—(N.208535p).

	\$
O'Connor & Gilligan Pty. Ltd. (Architects)	87 000.00
W. L. Meinhardt & Partners (Electrical and Hydraulic Engineers)	20 500.00

TOM FORRISTAL

Clerk of the Executive Council

At the Executive Council Chamber
Melbourne, 6 July 1982

Police Offences Act 1958, No. 6337

DIVISION 1A—STATE CLASSIFICATION OF PUBLICATIONS BOARD

Take note that the State Classification of Publications Board has classified the following publications in accordance with the provisions of section 180H (1) of the Police Offences Act 1958.

Each publication shall be subject to the following restrictions:

- It shall not be offered for sale, sold or delivered to any person under the age of eighteen years;
- It shall not be made available for inspection or perusal by any person under the age of eighteen years.

SCHEDULE OF PUBLICATIONS

Title	Distributor
Galerie—No. 1—1980	Claredale Holdings Pty. Ltd.
International Cover Models No. 16	Hallmark Book Wholesalers
Men Only—Vol. 43 No. 12	Hallmark Book Wholesalers
Men Only—Vol. 44 No. 2	Hallmark Book Wholesalers
Strip-Review No. 1	Claredale Holdings Pty. Ltd.

R. V. DOOLEY, Acting Secretary
State Classification of Publications Board

Police Offences Act 1958, No. 6337

DIVISION 1A—STATE CLASSIFICATION OF PUBLICATIONS BOARD

Take note that the State Classification of Publications Board has classified the following publications in accordance with the provisions of section 180H (1) of the Police Offences Act 1958.

Each publication shall be subject to the following restrictions:

- It shall not be offered for sale, sold or delivered to any person under the age of eighteen years;
- It shall not be made available for inspection or perusal by any person under the age of eighteen years;
- It shall not be exhibited or displayed in any place to which persons under the age of eighteen years have access or so that it is visible from any such place.

SCHEDULE OF PUBLICATIONS

Title	Distributor
Ellen's Easy	Hallmark Book Wholesalers
Jazzing Jill	Hallmark Book Wholesalers
Little Girls—No. 5	Claredale Holdings Pty. Ltd.
Madame—Vol. 7 No. 11	Claredale Holdings Pty. Ltd.
My Mistress No. 8	Claredale Holdings Pty. Ltd.
Ripe and Randy	Hallmark Book Wholesalers
Smooth No. 40	Claredale Holdings Pty. Ltd.
Secret Joys of Sexual Fulfillment, The	Venus Enterprises Pty. Ltd.
Tranz No. 26	Claredale Holdings Pty. Ltd.
World of Transvestism, The Vol. 3 No. 1	Claredale Holdings Pty. Ltd.
Young and Dandy	Hallmark Book Wholesalers

R. V. DOOLEY, Acting Secretary
State Classification of Publications Board

Police Offences Act 1958, No. 6337

DIVISION 1A—STATE CLASSIFICATION OF PUBLICATIONS BOARD

Take note that the State Classification of Publications Board has classified the following publications in accordance with the provisions of section 180H (1) of the Police Offences Act 1958.

Each publication shall be subject to the following restrictions:

- (a) It shall not be offered for sale, sold or delivered to any person under the age of eighteen years;
- (b) It shall not be made available for inspection or perusal by any person under the age of eighteen years;
- (c) It shall not be exhibited or displayed in any place to which persons under the age of eighteen years have access or so that it is visible from any such place;

(d) It shall not be advertised in any manner whatsoever.

SCHEDULE OF PUBLICATIONS

Title	Distributor
Young Studs—Nova	Wathen Wholesale Pty. Ltd.
Rodox—Special Selection—No. 11	Venus Enterprises Pty. Ltd.

R. V. DOOLEY, Acting Secretary
State Classification of Publications Board

DEPARTMENT OF MINERALS AND ENERGY

AREA OF EXPLORATION LICENCE RELINQUISHED

No. 788; CRA Exploration Pty. Limited; 396 km², comprising Graticular Blocks Nos. 478, 549, 550, 621, 622 and 623 Hamilton Map Sheet.
The above area will become available again for Exploration Licence on 12 October 1982.

EXPLORATION LICENCE EXPIRED

No. 832; Barclay Exploration Pty. Ltd. and Graytown Mining Pty. Ltd.; 198 km², comprising Graticular Blocks Nos. 515, 586 and 587 Melbourne Map Sheet.

The above area will become available again for Exploration Licence on 12 October 1982.

SEARCH LICENCES EXPIRED

Nos. 1947, 1948, 1949 and 1950; Western Mining Corporation Limited; 2 ha, Parish of Clunes.

EXTRACTIVE INDUSTRY LICENCE GRANTED

No. 393-1; Rigby Bros. & Co. Pty. Limited; 5.4 ha, Parish of Konong Wootong.

D. R. WHITE
Minister for Minerals and Energy

VICTORIAN DAIRY INDUSTRY AUTHORITY ACT

U.H.T. EGG FLIP PRICE DETERMINATION 1982 (No. 1)

In accordance with the powers conferred by the Victorian Dairy Industry Authority Act 1977, the Victorian Dairy Industry Authority hereby determines that the following prices for U.H.T. Egg Flip shall take effect from 11 July 1982:

Product and Package (1)	Wholesale		Central Warehouse	Semi-Wholesale		Retail
	Ex-plant (2) cents per package	Delivered (3) cents per package	Delivered (4) cents per package	Ex-plant (5) cents per package	Delivered (6) cents per package	(7) cents per pack
Ultra Heat Treated Milk Carton— Egg Flip 250 ml (24 packs per package)	—	642	670	665	720	40

D. D. COOPER, Chairman of the Victorian Dairy Industry Authority

State Electricity Commission Acts

ELECTRICAL APPROVALS BOARD : WITHDRAWAL OF APPROVAL

Pursuant to Regulation 16 of the Electrical Approvals Regulations—Approval of Equipment, 1953, the State Electricity Commission of Victoria hereby gives notice that it has withdrawn approval of the undermentioned article:

Applicant	Article of Reference No.	Date of Certificate of Approval	Date of Withdrawal of Approval	Approvals Marking
Keating and Murphy (Sales) Pty. Ltd.	Electric Kettle Cat. No. K4 Ref. No. V74499	24.2.75	24.6.82	V/74499/K4

G. A. McINTYRE, Secretary

APPOINTMENTS

His Excellency the Governor of the State of Victoria, by and with the advice of the Executive Council thereof, has, by Orders made on 6 July 1982, been pleased to make the under-mentioned appointments, viz.:

DEPARTMENT OF COMMUNITY WELFARE SERVICES

Stipendiary Youth Parole Officers and Stipendiary Parole Officers

RYALL, LEONIE CLARE,
SINGLETON, MICHAEL TIMOTHY, and
THOMAS, NICHOLAS CHARLES,
to be Stipendiary Youth Parole Officers and Stipendiary Parole Officers respectively, pursuant to the provisions of section 8 (2) of the *Children's Court Act 1973*, section 507 (1) of the *Crimes Act 1958*, section 165 (1) and section 189 (2) of the *Community Welfare Services Act*.

Honorary Probation Officers

ALLEY, GEORGINA, "Illawong", Broadlands Road, East Bairnsdale,
KELLY, GLENIS, 28 Morgan Street, Bairnsdale, and
STARK, JOHN, Unit 3/34, McRae Street, East Bairnsdale,
to be Honorary Probation Officers for all Adult and Children's Courts in the State of Victoria, pursuant to the provisions of section 507 (2) of the *Crimes Act 1958* and section 9 of the *Children's Court Act 1973*.

HEALTH COMMISSION

Trustees of Public Cemeteries

ARDEN LANGSTON JOSEPH,
STANISLAUS BARRY FISH, and
PETER RAYMOND LISLE,
to be Trustees of the Ferntree Gully Public Cemetery, vice Alfred Owen, resigned, Ada Friberg and Edwin Leslie, resigned, Anthony Gale, resigned, Mavis Joyce Read, resigned, Ernest Bowtell, removed, Maxwell White, removed, Otto Frederick Lobert, removed.

JOHN CAMERON COEN, and
JOHN HUGHES,
to be Trustees of the Box Hill Public Cemetery, vice H. Harvey, resigned, and E. M. Date, resigned.

GARRY TROTTER,
KEITH LANDWEHR, and
JOHN WALLER,
to be Trustees of the Minyip Public Cemetery, vice N. A. Trotter, resigned, E. T. Landwehr, resigned, and T. H. Wood, resigned, pursuant to section 3 (1) of the *Cemeteries Act 1958*.

Superintendent of Mental Hospital and Training Centre

RUSSELL JAMES VICKERS, M.B.B.S., E.C.F.M.G.,
M.R.A.N.Z.C.P.
to be Superintendent of the Ararat Mental Hospital and Training Centre and Pleasant Creek Training Centre, Stawell, pursuant to the provisions of section 26 (1) of the *Mental Health Act 1959*, for period 10 July 1982, to 18 July 1982, vice B. M. Currie, on leave.

LAW DEPARTMENT

Justices of the Peace

NORMAN ROBBIE ELSOM, 15 Koornalla Crescent, Mt. Eliza, and
OLGA VIRGINIA JACKSON, 1 Hilbert Court, Oakleigh,
to be Justices of the Peace for the State of Victoria.

Commissioners for Taking Declarations, &c.

BRIAN GARY GARTH, 20 Hazelwood Road, Morwell, and
ROBERT EDWARD POSSINGHAM, 14 Georgian Gardens,
Wantirna,
to be Commissioners for taking Declarations and Affidavits under the *Evidence Act 1958*.

DEPARTMENT OF CROWN LANDS AND SURVEY

Bailiffs of Crown Lands

LACHLAN NEIL JACKSON, and
BRIAN JAMES MARTIN, Officers of the Department of Crown Lands and Survey
to be bailiffs of Crown lands, pursuant to the provisions of section 30 of the *Land Act 1958*, in respect of all Crown lands situated in the Counties of Buln Buln and Mornington, and with authority to discharge and exercise all the duties and powers of bailiffs of Crown lands—(X.16B).

TOM FORRISTAL

Clerk of the Executive Council

At the Executive Council Chamber
Melbourne, 6 July 1982

Liquor Control Act 1968

APPOINTMENT OF LICENSING INSPECTOR

In accordance with the authority conferred upon me by Section 6 of the *Police Regulation Act 1958*, 1, John Roderick Hall, Deputy Commissioner of Police, do hereby appoint under sub-section (1) of Section 22 of the *Liquor Control Act 1968*, the following Officer of Police as a Licensing Inspector for the Division of the Police District as shown:

Division Number	Police District	Rank and Name
1	Heidelberg	Inspector Geoffrey Charles Tulloch (from 1.8.82 to 21.8.82)
8.7.1982		J. R. HALL Deputy Commissioner (Administration)

APPOINTMENT OF TRUSTEE

YARRA BEND PARK

His Excellency the Governor of the State of Victoria, by and with the advice of the Executive Council thereof, has, by Order made on 6 July 1982, pursuant to the provisions of section 6 of the *Kew and Heidelberg Land Acts Nos. 4194, 4843 and 6392*, appointed the undermentioned person as a Trustee of land in the Parishes of Boroondara and Jaka Jaka permanently reserved pursuant to Order in Council of 26 March 1935 as a site for Public Park and Recreation and known as "Yarra Bend Park":

JENNIFER BACKHOLER in the place of Terrence Scheikowski, provided that the said Jennifer Backholer shall hold office as a Trustee for so long only as she continues to be a Councillor and the elect of the Council of the City of Collingwood—(Rs.4368).

TOM FORRISTAL

Clerk of the Executive Council

At the Executive Council Chamber
Melbourne, 6 July 1982

APPOINTMENT OF TRUSTEE

SHRINE OF REMEMBRANCE, MELBOURNE

His Excellency the Governor of the State of Victoria, in the Commonwealth of Australia, by and with the advice of the Executive Council of the said State, pursuant to the provisions of section 3 of the *Shrine of Remembrance Act 1978*, has been pleased to make the undermentioned appointment, viz.:

Wing Commander REGINALD EDWARD BAILEY, D.S.O., O.B.E., D.F.C., in the place of Air Chief Marshal Sir Frederick Scherger, K.B.E., C.B., D.S.O., A.F.C., resigned,

to be a Trustee of the land in the City of Melbourne permanently reserved by Order in Council of 23 October 1933 (see *Government Gazette* dated 25 October 1933) as a site for a Monument known as the Shrine of Remembrance—(Rs.4333).

TOM FORRISTAL

Clerk of the Executive Council

At the Executive Council Chamber
Melbourne, 13 July 1982

DEPARTMENT OF CROWN LANDS AND SURVEY

APPOINTMENT OF COMMITTEE OF MANAGEMENT OF THE "DELIDIO RESERVE" DUNOLLY

His Excellency the Governor of the State of Victoria, by and with the advice of the Executive Council thereof, pursuant to the provisions of section 14 of the Crown Land (Reserves) Act 1978, has been pleased to appoint the undermentioned persons as the Committee of Management of the land in the Township of Dunolly permanently reserved for Public Recreation by Order in Council of 8 April 1872, in respect of which a Crown Grant has issued to the Minister of Lands and the President, Councillors and Ratepayers of the Shire of Bet Bet, and known as the "Delidio Reserve", viz.:

Thomas Andrew Peterson, Joseph Eric Graco, Stanley James Bryant, Brian Leslie Dolan, Bernard John Polinelli, Kenneth Thomas Howard, Allan Lindsay Lovel, Ian George Flett and Arthur Raymond Lacey.

This appointment is made in lieu of the appointments made on 11 December 1973 and 28 April 1981, with respect to the said land, which are hereby revoked—(Rs.3260).

TOM FORRISTAL
Clerk of the Executive Council

At the Executive Council Chamber
Melbourne, 6 July 1982

REVOCATION OF APPOINTMENTS

His Excellency the Governor of the State of Victoria, by and with the advice of the Executive Council thereof, has, by Orders made on 6 July 1982, revoked the appointments of the persons named hereunder to the offices mentioned viz.:

DEPARTMENT OF COMMUNITY WELFARE SERVICES

Honorary Probation Officers

ANGWIN, DES.,
ARKLAY, JUNE ALISON,
BARTON, JANE LYNETTE,
BLENKIRON, CHARLES THOMAS,
CLIFT, DIANA MARY,
GOSS, MARGARET,
GRECH, HELEN,
HAMLYN, BONNIE,
HAYES, GLORIA WANDA,
MCNAMARA, LOIS,
O'LEARY, TERENCE,
PIDOTO, TERENCE,
RIPPON, REX,
ROSS, JENNIFER DIANNE,
STACK, MARY, and
VIAL, RUSSELL,

as Honorary Probation Officers for all Adult and Children's Courts in Victoria, pursuant to the provisions of section 507 (2) of the Crimes Act 1958 and section 9 of the Children's Court Act 1973.

LAW DEPARTMENT

Justices of the Peace

RONALD LEON HARRIS HICKMAN, and
TERRENCE JAMES KEARINS,
as Justices of the the Peace for the State of Victoria.

Commissioners for Taking Declarations, &c.

GEORGE WILLIAM HARRY BRADEN,
BENEDICT JOHN BRIAN,
WILLIAM JOHN HENRY DUNCAN,
BRUCE ASHTON JEFFREYS,
LLOYD CHARLES JOHNS, and
THOMAS EDWARD LAWLER,
as Commissioners for taking Declarations and Affidavits under the Evidence Act 1958.

TOM FORRISTAL
Clerk of the Executive Council

At the Executive Council Chamber
Melbourne, 6 July 1982

RESIGNATIONS

His Excellency the Governor of the State of Victoria, by and with the advice of the Executive Council thereof, has, by Orders made on 6 July 1982, accepted the resignations of the persons named hereunder of the offices mentioned, viz.:

HEALTH COMMISSION

Members of Committees of Management of Hospitals

GEORGE HOWARD HILLIER
as a Member of the Committee of Management of the Casterton Memorial Hospital, as from 26 May 1982.

ALEC EDWIN HENMAN
as a Member of the Committee of Management of the Kaniva District Hospital, as from 9 May 1982.

MUIR JACK MYER LAPIN
as a Member of the Committee of Management of the Korumburra District Hospital, as from 23 June 1982, in accordance with the provisions of section 63G (1) of the Hospitals and Charities Act 1958.

LAW DEPARTMENT

Commissioners for Taking Declarations, &c.

NORMAN ROBBIE ELSOM, and
KEVIN TOBIN,
as Commissioners for taking Declarations and Affidavits under the Evidence Act 1958.

TOM FORRISTAL
Clerk of the Executive Council

At the Executive Council Chamber
Melbourne, 6 July 1982

ORDERS IN COUNCIL

LOCAL GOVERNMENT ACT 1958

At the Executive Council Chamber, Melbourne, the
sixth day of July, 1982

PRESENT:

His Excellency the Governor of Victoria

Mr Roper | Mr Trezise
Mr Wilkes |

CONSENT TO SALE OF A RESERVE BY THE KEW CITY COUNCIL

Whereas certain land being the Reserve for Drainage Purposes on Plan of Subdivision No. 2807 lodged in the Office of Titles was vested in the Council of the City of Kew pursuant to the provisions of section 569BA (1) of the Local Government Act 1958, by Order published in Government Gazette No. 102 of 19 November 1980 and the said Council is now of the opinion that the land is no longer required for the purpose for which it was reserved and has requested that consent be given to the sale of the land.

And whereas the said Council:

- (a) has published in a newspaper generally circulating in the municipal district a notice describing the land and the proposal for the sale of the land and stating that at the next ordinary meeting of the Council after the expiration of forty days after publication of the notice the Council would consider any objection to the proposal and would receive any representations as to the disposal of any purchase money;
- (b) there being no mortgagee chargee or lessee thereof has posted a similar notice upon the land in question.

And whereas no person has objected to the proposed sale of the land or made representations as to the disposal of any purchase money.

Now therefore, His Excellency the Governor of the State of Victoria, by and with the advice of the Executive Council thereof, and in pursuance of the provisions of sub-section (2) of section 569BA of the *Local Government Act 1958*, hereby consents to the Council of the City of Kew selling by private treaty the Reserve for Drainage Purposes on Plan of Subdivision No. 2807 lodged in the Office of Titles being the land shown by hatching on the plan hereunder.

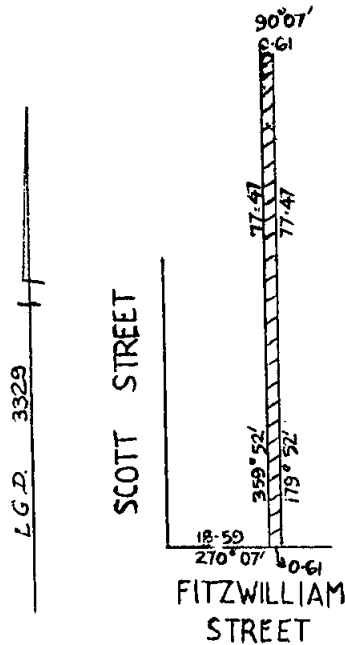

LENGTHS ARE IN METRES

And the Honourable Frank Noel Wilkes, Her Majesty's Minister for Local Government for the State of Victoria, shall give the necessary directions herein accordingly.

TOM FORRISTAL
Clerk of the Executive Council

LOCAL GOVERNMENT ACT 1958

At the Executive Council Chamber, Melbourne, the sixth day of July, 1982

PRESENT:

His Excellency the Governor of Victoria
Mr Roper | Mr Trezise
Mr Wilkes

VESTING OF LAND IN THE MILDURA SHIRE COUNCIL

Whereas it is provided by section 367 of the *Local Government Act 1958*, that the Governor in Council upon satisfactory evidence that property was taken possession of by a council at least thirty years previously and that no person has performed the conditions entitling him to demand a release of such property and that the property has not been sold in accordance with the provisions of Division 6 of Part XII. of the said Act, may by Order published in the *Government Gazette* describing such property declare the same to be vested in the municipality.

And whereas the Council of the Shire of Mildura has requested that the property described as Block H, Parish of Mildura be vested in Council,

And whereas the Governor in Council is satisfied that the said property has been in the possession of the Council of the Shire of Mildura for a period in excess of thirty years and that no demand for the release of the property has been made and that the property has not been sold as before mentioned.

Now therefore, His Excellency the Governor of the State of Victoria, by and with the advice of the Executive Council thereof, and in pursuance of the provisions of section 367 (1) of the *Local Government Act 1958* doth by this Order declare that the property described as Block H, Parish of Mildura shall vest in the Council of the Shire of Mildura.

And the Honourable Frank Noel Wilkes, Her Majesty's Minister for Local Government for the State of Victoria, shall give the necessary directions herein accordingly.

TOM FORRISTAL
Clerk of the Executive Council

LOCAL GOVERNMENT ACT 1958

At the Executive Council Chamber, Melbourne, the sixth day of July, 1982

PRESENT:

His Excellency the Governor of Victoria
Mr Roper | Mr Trezise
Mr Wilkes

ROAD RETAINED—CITY OF BROADMEADOWS

Whereas it is provided by paragraph (baa) of sub-section (2) of section 528 of the *Local Government Act 1958*, that where pursuant to an Order made by the Governor in Council under the provisions of that section or any corresponding previous enactment as in force before the commencement of the *Local Government (Amendment) Act 1962* any road or part of a road was discontinued and the land and soil thereof vested in the municipality, then if the said land or part thereof has not been sold the Governor in Council may by a further Order published in the *Government Gazette* direct that the land or part thereof shall be retained by the municipality for municipal purposes.

And whereas by an Order made under the said sub-section and published in the *Government Gazette* of 21 March 1973, the Governor in Council directed that the part of a road indicated by hatching on the plan hereunder be discontinued.

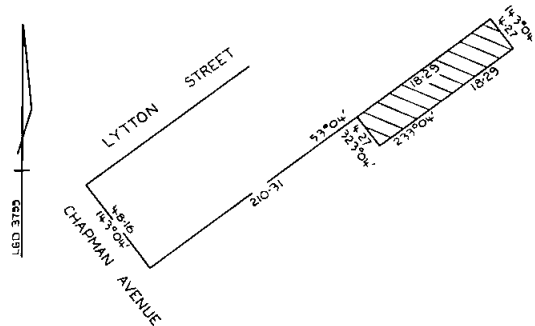

MEASUREMENTS ARE IN METRES

And whereas part of the land in the said discontinued part of a road remains unsold.

Now therefore, His Excellency the Governor of the State of Victoria by and with the advice of the Executive Council thereof, hereby directs that the land in that part of the road shown by hatching on the said plan shall be retained by the Council of the City of Broadmeadows for municipal purposes.

And the Honourable Frank Noel Wilkes, Her Majesty's Minister for Local Government for the State of Victoria, shall give the necessary directions herein accordingly.

TOM FORRISTAL
Clerk of the Executive Council

CROWN LAND (RESERVES) ACT 1978

At the Executive Council Chamber, Melbourne, the sixth day of July, 1982

PRESENT:

His Excellency the Governor of Victoria
 Mr Roper | Mr Trezise
 Mr Wilkes |

CROWN LANDS TEMPORARILY RESERVED

His Excellency the Governor of the State of Victoria, in the Commonwealth of Australia, by and with the advice of the Executive Council of the said State, pursuant to the provisions of sections 4 and 7 of the Crown Land (Reserves) Act 1978, and being of the opinion that the Crown lands concerned are required for the public purposes respectively mentioned, doth hereby temporarily reserve and also except from prospecting or from occupation for mining purposes under any miner's right, the Crown lands hereinafter described, viz.:

BEAUFORT—For Department of Crown Lands and Survey purposes, 4913 square metres, being Crown allotment 12, Section 12, Township of Beaufort, as shown on Certified Plan No. 105200 lodged in the Central Plan Office—(B.304^(*)) (Rs.11087).

CARDIGAN—For Health Commission purposes, 2744 square metres, being Crown allotment 3A, Section 4, Parish of Cardigan, as indicated by hatching on plan hereunder—(Parish 2344) (Rs.11826).

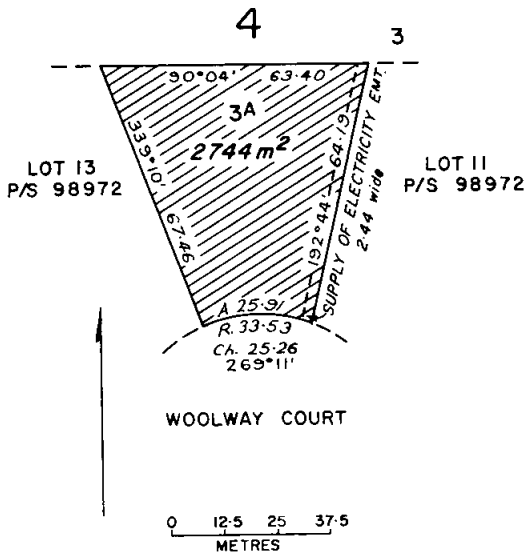

CROWN LAND (RESERVES) ACT 1978

At the Executive Council Chamber, Melbourne, the sixth day of July, 1982

PRESENT:

His Excellency the Governor of Victoria
 Mr Roper | Mr Trezise
 Mr Wilkes |

CROWN LAND PERMANENTLY RESERVED

His Excellency the Governor of the State of Victoria, in the Commonwealth of Australia, by and with the advice of the Executive Council of the said State, pursuant to the provisions of sections 4 and 7 of the Crown Land (Reserves) Act 1978, and being of the opinion that the Crown land concerned is required for the purpose mentioned, doth hereby permanently reserve and also except from prospecting or from occupation for mining purposes under any miner's right, the Crown land hereinafter described, viz.:

BEECHWORTH—For Public Recreation, 11.9 hectares, more or less, being Crown allotments 8A and 8b, Section H, Parish of Beechworth, as indicated by hatching on plan hereunder—(B.349⁽²²⁾) (Rs.11638).

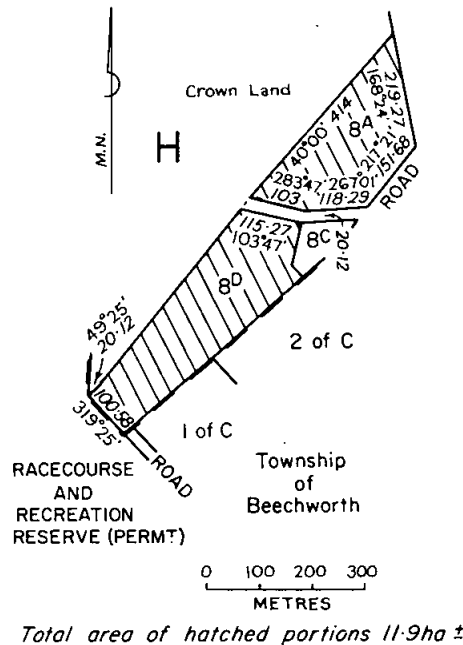

And the Honourable Roderick Alexander Mackenzie, Her Majesty's Minister of Lands for the State of Victoria, shall give the necessary directions herein accordingly.

TOM FORRISTAL
 Clerk of the Executive Council

And the Honourable Roderick Alexander Mackenzie, Her Majesty's Minister of Lands for the State of Victoria, shall give the necessary directions herein accordingly.

TOM FORRISTAL
 Clerk of the Executive Council

CROWN LAND (RESERVES) ACT 1978

At the Executive Council Chamber, Melbourne, the sixth day of July, 1982

PRESENT:

His Excellency the Governor of Victoria
 Mr Roper | Mr Trezise
 Mr Wilkes |

CROWN LANDS TEMPORARILY RESERVED

His Excellency the Governor of the State of Victoria, in the Commonwealth of Australia, by and with the advice of the Executive Council of the said State, pursuant to the provisions of sections 4 and 7 of the Crown Land (Reserves) Act 1978, and being of the opinion that the Crown lands concerned are required for the purposes respectively mentioned, doth hereby temporarily reserve and also except from prospecting or from occupation for mining purposes under any miner's right, the Crown lands hereinafter described, viz.:

BEMM—For Camping purposes—6500 square metres, more or less, being Crown allotments 15 and 16, section A, Township of Bemm, as indicated by hatching on plan hereunder—(B.728⁽⁵⁾) (Rs.4216).

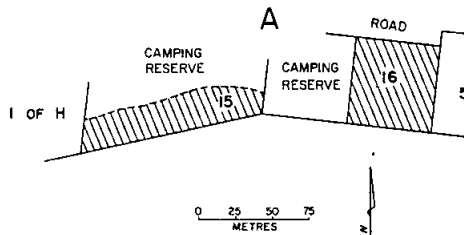

Total area of hatched portions 6500m² ±

BRIGHT—For Public Recreation and Camping—782 square metres, being Crown allotment 7, section 4A, Township of Bright, as indicated by hatching on plan hereunder—(B.573⁽⁵⁾) (Rs.3832).

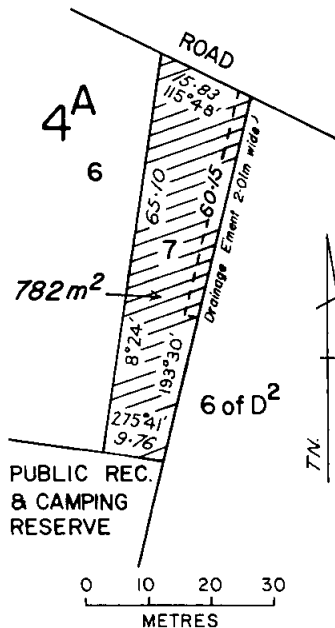

KANGAROO FLAT—For Public Park—5 543 hectares, being Crown allotment 13, section 20, Township of Kangaroo Flat, as shown on Certified Plan No. 104924 lodged in the Central Plan Office—(K.217⁽²⁾) (Rs.4987).

And the Honourable Roderick Alexander Mackenzie, Her Majesty's Minister of Lands for the State of Victoria, shall give the necessary directions herein accordingly.

TOM FORRISTAL
 Clerk of the Executive Council

CROWN LAND (RESERVES) ACT 1978

At the Executive Council Chamber, Melbourne, the sixth day of July, 1982

PRESENT:

His Excellency the Governor of Victoria
 Mr Roper | Mr Trezise
 Mr Wilkes |

RESERVED CROWN LAND PLACED UNDER THE CONTROL AND MANAGEMENT OF THE FORESTS COMMISSION

His Excellency the Governor of the State of Victoria, in the Commonwealth of Australia, by and with the advice of the Executive Council of the said State, pursuant to the provisions of section 18 (1) of the Crown Land (Reserves) Act 1978, doth hereby place under the control and management of the Forests Commission, the Crown land hereinafter described, viz.:

EUREKA—The land being Crown allotment 5A in the Parish of Eureka permanently reserved for Preservation of Species of Native Plants by Order in Council of 27 April 1982 (see Government Gazette dated 5 May 1982)—(Rs.11712).

And the Honourable Roderick Alexander Mackenzie, Her Majesty's Minister of Lands for the State of Victoria, shall give the necessary directions herein accordingly.

TOM FORRISTAL
 Clerk of the Executive Council

CROWN LAND (RESERVES) ACT 1978

At the Executive Council Chamber, Melbourne, the sixth day of July, 1982

PRESENT:

His Excellency the Governor of Victoria
 Mr Roper | Mr Trezise
 Mr Wilkes |

RESERVED CROWN LAND PLACED UNDER THE CONTROL AND MANAGEMENT OF THE FORESTS COMMISSION

His Excellency the Governor of the State of Victoria, in the Commonwealth of Australia, by and with the advice of the Executive Council of the said State, pursuant to the provisions of section 18 (1) of the Crown Land (Reserves) Act 1978, doth hereby place under the control and management of the Forests Commission, the Crown land hereinafter described, viz.:

MOOROOLBARK—The land in the Parish of Mooroolbark temporarily reserved for a Public Park by Order in Council of 3 June 1953 (see Government Gazette dated 10 June 1953)—(Rs.7114).

And the Honourable Roderick Alexander Mackenzie, Her Majesty's Minister of Lands for the State of Victoria, shall give the necessary directions herein accordingly.

TOM FORRISTAL
 Clerk of the Executive Council

CROWN LAND (RESERVES) ACT 1978

At the Executive Council Chamber, Melbourne, the sixth day of July, 1982

PRESENT:

His Excellency the Governor of Victoria

Mr Roper		Mr Trezise
Mr Wilkes		

REVOCATION OF TEMPORARY RESERVATIONS OF LANDS BY ORDERS IN COUNCIL

His Excellency the Governor of the State of Victoria, in the Commonwealth of Australia, by and with the advice of the Executive Council of the said State, pursuant to the provisions of section 10 of the *Crown Land (Reserves) Act 1978*, doth hereby revoke the temporary reservations of lands by Orders in Council hereinafter described, viz.:

BALNARRING—The temporary reservation by Order in Council of 11 January 1977 of 4.047 hectares of land in the Parish of Balnarring, being Crown allotment B³, section 78, for Public Purposes (Preservation of Landscape)—(B.74^(e)) (Rs.5433).

BOOMAHNOOMOONAH, BUNDALONG, PELLUEBLA AND YARRAWONGA (DOWDLE'S SWAMP)—The temporary reservation by Order in Council of 19 May 1970 of 291 hectares, more or less, of land in the Parishes of Boomahnoomoonah, Bundalong, Pelluebla and Yarrowonga as a site for Public Purposes (Conservation of Wildlife)—(Rs.1422).

POLISBET—The temporary reservation by Order in Council of 25 May 1960 of 16.02 hectares of land in the Parish of Polisbet (adjoining allotment 5c) as a site for Water Supply purposes—(P.170(A¹)) (Rs.7925).

YANGERAHILL AND STOCKYARD HILL—The temporary reservation by Order in Council of 21 June 1960 of 878 hectares, more or less, of land in the Parish of Yangerahwill and the Township of Stockyard Hill as a site for the Preservation of Wildlife—(Rs.7941).

BALLARAT—The temporary reservation by Order in Council of 31 January 1973 of 3.642 hectares, more or less, of land in the Township of Ballarat as a site for Railway Purposes, so far only as the portion thereof containing 117 square metres, as defined by description and hatching on plan published in the *Government Gazette* dated 16 June 1982, is concerned—(B.128^(a)) (B.128^(b)) (C.76779).

BENALLA—The temporary reservation by Order in Council of 30 August 1966 of 1.889 hectares, more or less, of land in the Parish of Benalla as a site for Public Purposes (Municipal Depot) (in section F), revoked as to part by Order of 2 December 1968, so far as the balance thereof containing 1.307 hectares, is concerned—(B.392^(c)) (Rs.8203).

HAMILTON—The temporary reservation by Order in Council of 18 September 1961 of 4426 square metres of land in the Township of Hamilton (in two separate portions) as a site for Public Purposes, so far only as the portion thereof containing 1695 square metres, as defined by description and hatching on plan published in the *Government Gazette* dated 16 June 1982, is concerned—(H.45⁽³⁾) (Rs.8068).

And the Honourable Roderick Alexander Mackenzie, Her Majesty's Minister of Lands for the State of Victoria, shall give the necessary directions herein accordingly.

TOM FORRISTAL
Clerk of the Executive Council

SUPERANNUATION ACT 1958

At the Executive Council Chamber, Melbourne, the sixth day of July, 1982

PRESENT:

His Excellency the Governor of Victoria

Mr Roper		Mr Trezise
Mr Wilkes		

Pursuant to the powers conferred by the provisions of paragraph (ja) of subsection (1) of Section 3 of the *Superannuation Act 1958*, His Excellency the Governor of the State of Victoria, by and with the advice of the Executive Council thereof doth by this Order declare that the provisions of the *Superannuation Act* shall continue to apply to Robert Kiam Seng Tong who, as from and inclusive of 18 June 1982 is an officer of the Footscray Institute of Technology.

And the Honourable Robert Allen Jolly, Her Majesty's Treasurer for the State of Victoria, shall give the necessary directions herein accordingly.

TOM FORRISTAL
Clerk of the Executive Council

SUPERANNUATION ACT 1958

At the Executive Council Chamber, Melbourne, the sixth day of July, 1982

PRESENT:

His Excellency the Governor of Victoria

Mr Roper		Mr Trezise
Mr Wilkes		

Pursuant to the powers conferred by the provisions of paragraph (ja) of subsection (1) of Section 3 of the *Superannuation Act 1958*, His Excellency the Governor of the State of Victoria, by and with the advice of the Executive Council thereof doth by this Order declare that the provisions of the *Superannuation Act* shall apply to the officers named in the schedule set out hereunder.

SCHEDULE

COLLINS, YOLANDE MARIA JOHANNA, Bendigo College of Advanced Education.
MILLAR, COLIN STANLEY, Bendigo College of Advanced Education.
MOLLISON, JUSTIN FRANK, Bendigo College of Advanced Education.

And the Honourable Robert Allen Jolly, Her Majesty's Treasurer for the State of Victoria, shall give the necessary directions herein accordingly.

TOM FORRISTAL
Clerk of the Executive Council

SUPERANNUATION ACT 1958

At the Executive Council Chamber, Melbourne, the sixth day of July, 1982

PRESENT:

His Excellency the Governor of Victoria

Mr Roper		Mr Trezise
Mr Wilkes		

Whereas the under-mentioned officers have become officers after the commencement of the *Superannuation (Amendment) Act 1970*; and whereas the State Superannuation Board of Victoria has pursuant to the provisions of sub-section (3) of the section 13DA of the *Superannuation Act* recommended that the said officers be deemed to have the additional years of prospective service as detailed opposite their respective names under the heading Recommended Number of Additional Years of Prospective Service in the Schedule set out hereunder for

the purposes of determining their unit entitlement pursuant to the provisions of sub-section (1A) of section 13DA of the Superannuation Act 1958; now therefore, His Excellency the Governor of the State of Victoria, acting by and with the advice of the Executive Council thereof, doth hereby declare that the said officers shall be deemed to have the said additional years of prospective service.

SCHEDULE

Name	Recommended Number of Additional Years of Prospective Service
ALGER, NORAH	5
BLAIN, ERIC STUART	1
FARQUHAR, DALLAS ARTHUR	9
HOPE, DONALD WILLIAM	3
JOINER, MARGARET VERONICA	1
KOUMOUKELIS, PETER	3
MAJOR, GEOFFREY WILLIAM	9
MORABEX, ANIS	3
MCGIBBON, GEORGE	4
MCKAY, GORDON	13
ROBINSON, MARJORIE	1
WOOD, KEITH HENRY	9
YOUAKIM, MORRIS RAFLAH	8

And the Honourable Robert Allen Jolly, Her Majesty's Treasurer for the State of Victoria, shall give the necessary directions herein accordingly.

TOM FORRISTAL
Clerk of the Executive Council

LAND ACT 1958

At the Executive Council Chamber, Melbourne, the sixth day of July, 1982

PRESENT:

His Excellency the Governor of Victoria
Mr Roper | Mr Trezise
Mr Wilkes

UNUSED ROADS CLOSED

His Excellency the Governor of the State of Victoria, in the Commonwealth of Australia, by and with the advice of the Executive Council of the said State, pursuant to the provisions of Section 349 of the Land Act 1958 and with the concurrence in writing of the council of the municipality concerned and that of any adjoining land owners, doth hereby close the unused roads hereinafter described, viz.:

Municipal District of the Town of Bairnsdale—Township of Bairnsdale, being the roads indicated by hatching on plan hereunder—(B.66⁽²⁾) (L.9-1109).

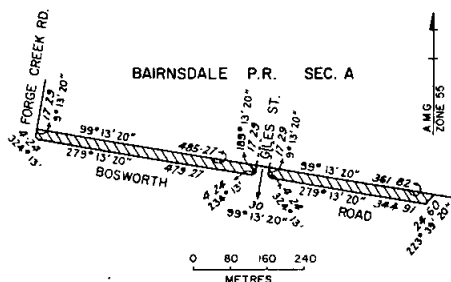

Municipal District of the Shire of Eltham—Township of Queenstown, being the road indicated by hatching on plan hereunder—(Q.22⁽⁶⁾) (C.77505).

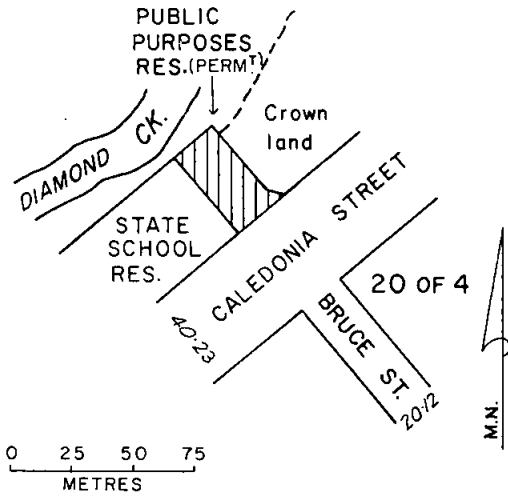

Municipal District of the Shire of Metcalfe—Township of Sutton Grange, being the road indicated by hatching on plan hereunder—(S.352⁽⁴⁾) (L.6-726).

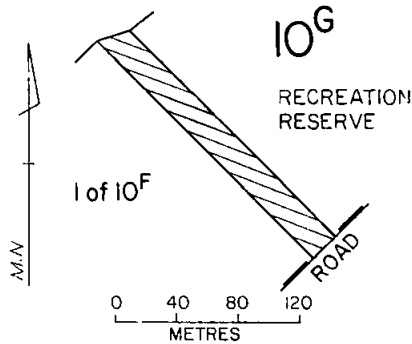

And the Honourable Roderick Alexander Mackenzie, Her Majesty's Minister of Lands for the State of Victoria, shall give the necessary directions herein accordingly.

TOM FORRISTAL
Clerk of the Executive Council

THORPDALE WATERWORKS TRUST

At the Executive Council Chamber, Melbourne, the sixth day of July, 1982

PRESENT:

His Excellency the Governor of Victoria
Mr Roper | Mr Trezise
Mr Wilkes

EXTENT OF WATERWORKS DISTRICT INCREASED AND SITES OF PIPELINE AND STORAGE APPROVED

Under the powers conferred by the Water Act, and all other powers enabling him in that behalf, His Excellency the Governor of the State of Victoria, by and with the advice of the Executive Council of the said State, doth hereby—

- (a) declare, order and direct that the extent of the Waterworks District of the Thorpdale Waterworks Trust be increased by adding the area shown within the red border on the plan approved by the Governor in Council, by and with this Order, and deposited in the office of the State Rivers

and Water Supply Commission, Melbourne (Corr. No. 64/1431/78) and as on and from the date hereof the extent of such district shall be increased accordingly;

- (b) approve of the sites of a pipeline and storage shown brown and yellow respectively on the said plan.

And the Honourable David Ronald White, Her Majesty's Minister of Water Supply for the State of Victoria, shall give the necessary directions herein accordingly.

TOM FORRISTAL
Clerk of the Executive Council

SEASPRAY WATERWORKS TRUST

At the Executive Council Chamber, Melbourne, the sixth day of July, 1982

PRESENT:

His Excellency the Governor of Victoria
Mr Roper | Mr Trezise
Mr Wilkes |

APPROVAL OF SITE OF STORAGE

Under the powers conferred by the Water Act and all other powers enabling him in that behalf, His Excellency the Governor of the State of Victoria, by and with the advice of the Executive Council of the said State, doth hereby approve of the site for a storage required by the Seaspray Waterworks Trust, being the land shown by pink colour on the plan approved by the Governor in Council, by and with this Order and deposited in the Office of the State Rivers and Water Supply Commission, Melbourne (Corr. No. 80/0935/16).

And the Honourable David Ronald White, Her Majesty's Minister of Water Supply for the State of Victoria, shall give the necessary directions herein accordingly.

TOM FORRISTAL
Clerk of the Executive Council

CEMETERIES ACT 1958

At the Executive Council Chamber, Melbourne, the sixth day of July, 1982

PRESENT:

His Excellency the Governor of Victoria
Mr Roper | Mr Trezise
Mr Wilkes |

FERNTREE GULLY PUBLIC CEMETERY

Whereas pursuant to section 5 of the *Cemeteries Act 1958* the Governor in Council may from time to time as and when he thinks proper remove from the said Trusts any Trustee of any such cemetery; and also upon the death, resignation or removal of any trustee appointed under this Act may appoint another in his stead.

And whereas it is considered proper that the Trustees of the Ferntree Gully Public Cemetery be removed.

Now therefore His Excellency the Governor in Council by and with the advice of the Executive Council of the said State hereby:

1. Accepts the resignations of MAVIS JOYCE READ, ADA FRIDBERG, EDWIN LESLIE ANTHONY GALE and ALFRED OWEN; as Trustees of the Ferntree Gully Public Cemetery.
2. Removes ERNEST BOWTELL, OTTO FREDERICK LOBERT and MAXWELL WHITE; as Trustees of the Ferntree Gully Public Cemetery.

And the Honourable Thomas William Roper, Her Majesty's Minister of Health for the State of Victoria, shall give the necessary directions herein accordingly.

TOM FORRISTAL
Clerk of the Executive Council

PORT OF PORTLAND AUTHORITY ACT 1958

At the Executive Council Chamber, Melbourne, the sixth day of July, 1982

PRESENT:

His Excellency the Governor of Victoria
Mr Roper | Mr Trezise
Mr Wilkes |

Whereas His Excellency the Governor of the State of Victoria, by and with the advice of the Executive Council thereof, has this day consented pursuant to the provisions of the *Port of Portland Authority Act 1958* to the Port of Portland Authority raising by way of a loan the sum of Five hundred thousand dollars (\$500 000); and whereas the Governor in Council is satisfied that a sufficient proportion of the loan to be raised will fall due and be repaid in each year during the currency of the proposed loan; now therefore it is directed pursuant to the provisions of section 33 (3) of the said Act, that it shall not be necessary to provide a sinking fund in connection with such loan.

And the Honourable Robert Allen Jolly, Her Majesty's Treasurer for the State of Victoria, shall give the necessary directions herein accordingly.

TOM FORRISTAL
Clerk of the Executive Council

HISTORIC BUILDINGS ACT 1981 (No. 9667)

At the Executive Council Chamber, Melbourne, the thirteenth day of July, 1982

PRESENT:

His Excellency the Governor of Victoria
Mr Mathews | Mrs Toner

AMENDMENT OF REGISTER OF HISTORIC BUILDINGS

Whereas it is provided by section 14 of the *Historic Buildings Act 1981* that the Governor in Council, on the recommendation of the Minister, may by notice published in the *Government Gazette*, amend the Register of Historic Buildings established under the said Act—

- (a) by adding any specified building;
- (b) by removing any specified building; or
- (c) by altering any item.

And whereas the Minister has recommended that the Register be amended.

Now therefore His Excellency the Governor of the State of Victoria, by and with the advice of the Executive Council thereof, doth hereby amend the Register of Historic Buildings in the manner and to the extent shown as follows: by adding

"Historic Building No. 20 Christian Brothers College, 256-278 Victoria Parade, East Melbourne," to:

"Cathedral College, 256-278 Victoria Parade, East Melbourne (to the extent of the whole of the land, boundary fences to the Victoria Parade and Eades Street frontages, and building No. 1 shown outlined in red on the plan held by the Department of Planning, but, without limiting the foregoing, excluding buildings Nos. 2, 3, 4, 5 and 6 on the same plan)."

The "whole of the land" refers to that land described in Certificates of Title, Volume 8598, Folio 538; Volume 8598, Folio 539; Volume 8598 Folio 540; Volume 3621, Folio 013.

And the Honourable Evan Walker, Her Majesty's Minister for Planning for the State of Victoria, shall give the necessary directions herein accordingly.

TOM FORRISTAL
Clerk of the Executive Council

HISTORIC BUILDINGS ACT 1981 (No. 9667)

At the Executive Council Chamber, Melbourne, the
thirteenth day of July, 1982

PRESENT:

His Excellency the Governor of Victoria
Mr Mathews | Mrs Toner

AMENDMENT OF REGISTER OF HISTORIC BUILDINGS

Whereas it is provided by section 14 of the *Historic Buildings Act 1981* that the Governor in Council, on the recommendation of the Minister, may by notice published in the *Government Gazette*, amend the Register of Historic Buildings established under the said Act—

- (a) by adding any specified building;
- (b) by removing any specified building; or
- (c) by altering any item.

And whereas the Minister has recommended that the Register be amended.

Now therefore His Excellency the Governor of the State of Victoria, by and with the advice of the Executive Council thereof, doth hereby amend the Register of Historic Buildings in the manner and to the extent shown as follows: by adding

"Historic Building No. 535 Chandos, 44 Hotham Street, East Melbourne."

And the Honourable Evan Walker, Her Majesty's Minister for Planning for the State of Victoria, shall give the necessary directions herein accordingly.

TOM FORRISTAL
Clerk of the Executive Council

HISTORIC BUILDINGS ACT 1981 (No. 9667)

At the Executive Council Chamber, Melbourne, the
thirteenth day of July, 1982

PRESENT:

His Excellency the Governor of Victoria
Mr Mathews | Mrs Toner

AMENDMENT OF REGISTER OF HISTORIC BUILDINGS

Whereas it is provided by section 14 of the *Historic Buildings Act 1981* that the Governor in Council, on the recommendation of the Minister, may by notice published in the *Government Gazette*, amend the Register of Historic Buildings established under the said Act—

- (a) by adding any specified building;
- (b) by removing any specified building; or
- (c) by altering any item.

And whereas the Minister has recommended that the Register be amended.

Now therefore His Excellency the Governor of the State of Victoria, by and with the advice of the Executive Council thereof, doth hereby amend the Register of Historic Buildings in the manner and to the extent shown as follows: by adding

"Historic Building No. 534 Former ES&A Bank, Corner Burke and Riversdale Roads, East Hawthorn."

And the Honourable Evan Walker, Her Majesty's Minister for Planning for the State of Victoria, shall give the necessary directions herein accordingly.

TOM FORRISTAL
Clerk of the Executive Council

HISTORIC BUILDINGS ACT 1981 (No. 9667)

At the Executive Council Chamber, Melbourne, the
thirteenth day of July, 1982

PRESENT:

His Excellency the Governor of Victoria
Mr Mathews | Mrs Toner

AMENDMENT OF REGISTER OF HISTORIC BUILDINGS

Whereas it is provided by section 14 of the *Historic Buildings Act 1981* that the Governor in Council, on the recommendation of the Minister, may by notice published in the *Government Gazette*, amend the Register of Historic Buildings established under the said Act—

- (a) by adding any specified building;
- (b) by removing any specified building; or
- (c) by altering any item.

And whereas the Minister has recommended that the Register be amended.

Now therefore His Excellency the Governor of the State of Victoria, by and with the advice of the Executive Council thereof, doth hereby amend the Register of Historic Buildings in the manner and to the extent shown as follows: by adding—

"Historic Building No. 531—Former Literary and Scientific Institute, 54 Longfield Street, Stawell."

And the Honourable Evan Walker, Her Majesty's Minister for Planning for the State of Victoria, shall give the necessary directions herein accordingly.

TOM FORRISTAL
Clerk of the Executive Council

HISTORIC BUILDINGS ACT 1981 (No. 9667)

At the Executive Council Chamber, Melbourne, the
thirteenth day of July, 1982

PRESENT:

His Excellency the Governor of Victoria
Mr Mathews | Mrs Toner

AMENDMENT OF REGISTER OF HISTORIC BUILDINGS

Whereas it is provided by section 14 of the *Historic Buildings Act 1981* that the Governor in Council, on the recommendation of the Minister, may by notice published in the *Government Gazette*, amend the Register of Historic Buildings established under the said Act—

- (a) by adding any specified building;
- (b) by removing any specified building; or
- (c) by altering any item.

And whereas the Minister has recommended that the Register be amended.

Now therefore His Excellency the Governor of the State of Victoria, by and with the advice of the Executive Council thereof, doth hereby amend the Register of Historic Buildings in the manner and to the extent shown as follows: by adding—

"Historic Building No. 532—Church of the Holy Annunciation, 186 Victoria Parade, East Melbourne."

And the Honourable Evan Walker, Her Majesty's Minister for Planning for the State of Victoria, shall give the necessary directions herein accordingly.

TOM FORRISTAL
Clerk of the Executive Council

HISTORIC BUILDINGS ACT 1981 (No. 9667)

At the Executive Council Chamber, Melbourne, the
thirteenth day of July, 1982

PRESENT:

His Excellency the Governor of Victoria
Mr Mathews | Mrs Toner

AMENDMENT OF REGISTER OF HISTORIC BUILDINGS

Whereas it is provided by section 14 of the *Historic Buildings Act 1981* that the Governor in Council, on the recommendation of the Minister, may by notice published in the *Government Gazette*, amend the Register of Historic Buildings established under the said Act—

- (a) by adding any specified building;
- (b) by removing any specified building; or
- (c) by altering any item.

And whereas the Minister has recommended that the Register be amended.

Now therefore His Excellency the Governor of the State of Victoria, by and with the advice of the Executive Council thereof, doth hereby amend the Register of Historic Buildings in the manner and to the extent shown as follows: by adding—

"Historic Building No. 533—Former Talbot Police Residence and Lock-Up, Heales Street, Talbot (to the extent of the bluestone lock-up, the brick stable and the external fabric of the brick part of the residence)."

And the Honourable Evan Walker, Her Majesty's Minister for Planning for the State of Victoria, shall give the necessary directions herein accordingly.

TOM FORRISTAL
Clerk of the Executive Council

HISTORIC BUILDINGS ACT 1981 (No. 9667)

At the Executive Council Chamber, Melbourne, the
thirteenth day of July, 1982

PRESENT:

His Excellency the Governor of Victoria
Mr Mathews | Mrs Toner

AMENDMENT OF REGISTER OF HISTORIC BUILDINGS

Whereas it is provided by section 14 of the *Historic Buildings Act 1981* that the Governor in Council, on the recommendation of the Minister, may by notice published in the *Government Gazette*, amend the Register of Historic Buildings established under the said Act—

- (a) by adding any specified building;
- (b) by removing any specified building; or
- (c) by altering any item.

And whereas the Minister has recommended that the Register be amended.

Now therefore His Excellency the Governor of the State of Victoria, by and with the advice of the Executive Council thereof, doth hereby amend the Register of Historic Buildings in the manner and to the extent shown as follows: by adding—

"Historic Building No. 536—Welsh Church and Hall, 320 Latrobe Street, Melbourne."

And the Honourable Evan Walker, Her Majesty's Minister for Planning for the State of Victoria, shall give the necessary directions herein accordingly.

TOM FORRISTAL
Clerk of the Executive Council

HISTORIC BUILDINGS ACT 1981 (No. 9667)

At the Executive Council Chamber, Melbourne, the
thirteenth day of July, 1982

PRESENT:

His Excellency the Governor of Victoria
Mr Mathews | Mrs Toner

AMENDMENT OF REGISTER OF HISTORIC BUILDINGS

Whereas it is provided by section 14 of the *Historic Buildings Act 1981* that the Governor in Council, on the recommendation of the Minister, may by notice published in the *Government Gazette*, amend the Register of Historic Buildings established under the said Act—

- (a) by adding any specified building;
- (b) by removing any specified building; or
- (c) by altering any item.

And whereas the Minister has recommended that the Register be amended.

Now therefore His Excellency the Governor of the State of Victoria, by and with the advice of the Executive Council thereof, doth hereby amend the Register of Historic Buildings in the manner and to the extent shown as follows: by adding

"Historic Building No. 507 Convent of Mercy and Academy of Mary Immaculate, 88 Nicholson Street, Fitzroy (excluding the buildings defined by the plan held on the files of the Department of Planning)."

And the Honourable Evan Walker, Her Majesty's Minister for Planning for the State of Victoria, shall give the necessary directions herein accordingly.

TOM FORRISTAL
Clerk of the Executive Council

HISTORIC BUILDINGS ACT 1981 (No. 9667)

At the Executive Council Chamber, Melbourne, the
thirteenth day of July, 1982

PRESENT:

His Excellency the Governor of Victoria
Mr Mathews | Mrs Toner

AMENDMENT OF REGISTER OF HISTORIC BUILDINGS

Whereas it is provided by section 14 of the *Historic Buildings Act 1981* that the Governor in Council, on the recommendation of the Minister, may by notice published in the *Government Gazette*, amend the Register of Historic Buildings established under the said Act—

- (a) by adding any specified building;
- (b) by removing any specified building; or
- (c) by altering any item.

And whereas the Minister has recommended that the Register be amended.

Now therefore His Excellency the Governor of the State of Victoria, by and with the advice of the Executive Council thereof, doth hereby amend the Register of Historic Buildings in the manner and to the extent shown as follows: by adding

"Historic Building No. 515 'Raheen', Studley Park Road, Kew."

And the Honourable Evan Walker, Her Majesty's Minister for Planning for the State of Victoria, shall give the necessary directions herein accordingly.

TOM FORRISTAL
Clerk of the Executive Council

HISTORIC BUILDINGS ACT 1981 (No. 9667)

At the Executive Council Chamber, Melbourne, the
thirteenth day of July, 1982

PRESENT:

His Excellency the Governor of Victoria
Mr Mathews | Mrs Toner

AMENDMENT OF REGISTER OF HISTORIC BUILDINGS

Whereas it is provided by section 14 of the *Historic Buildings Act 1981* that the Governor in Council, on the recommendation of the Minister, may by notice published in the *Government Gazette*, amend the Register of Historic Buildings established under the said Act—

- (a) by adding any specified building;
- (b) by removing any specified building; or
- (c) by altering any item.

And whereas the Minister has recommended that the Register be amended.

Now therefore His Excellency the Governor of the State of Victoria, by and with the advice of the Executive Council thereof, doth hereby amend the Register of Historic Buildings in the manner and to the extent shown as follows: by adding

"Historic Building No. 537 Italian Club Cavour, 170-172 Cecil Street, South Melbourne (to the extent of the external fabric and the trussed ceiling of the main hall)."

And the Honourable Evan Walker, Her Majesty's Minister for Planning for the State of Victoria, shall give the necessary directions herein accordingly.

TOM FORRISTAL
Clerk of the Executive Council

HISTORIC BUILDINGS ACT 1981 (No. 9667)

At the Executive Council Chamber, Melbourne, the
thirteenth day of July, 1982

PRESENT:

His Excellency the Governor of Victoria
Mr Mathews | Mrs Toner

AMENDMENT OF REGISTER OF HISTORIC BUILDINGS

Whereas it is provided by section 14 of the *Historic Buildings Act 1981* that the Governor in Council, on the recommendation of the Minister, may by notice published in the *Government Gazette*, amend the Register of Historic Buildings established under the said Act—

- (a) by adding any specified building;
- (b) by removing any specified building; or
- (c) by altering any item.

And whereas the Minister has recommended that the Register be amended.

Now therefore His Excellency the Governor of the State of Victoria, by and with the advice of the Executive Council thereof, doth hereby amend the Register of Historic Buildings in the manner and to the extent shown as follows: by adding

"Historic Building No. 530 Tower Hill Common School, Victoria Park, High Street, Koroit."

And the Honourable Evan Walker, Her Majesty's Minister for Planning for the State of Victoria, shall give the necessary directions herein accordingly.

TOM FORRISTAL
Clerk of the Executive Council

GEELONG WATERWORKS AND SEWERAGE TRUST

At the Executive Council Chamber, Melbourne, the
thirteenth day of July, 1982

PRESENT:

His Excellency the Governor of Victoria
Mr Mathews | Mrs Toner

CONSENT TO BORROWING \$350 000

Under the powers conferred by the Geelong Waterworks and Sewerage Act and all other powers enabling him in that behalf, His Excellency the Governor of the State of Victoria, by and with the advice of the Executive Council of the said State, hereby consents to the Geelong Waterworks and Sewerage Trust borrowing the sum of Three hundred and fifty thousand dollars (\$350 000) for the conversion of Loan Nos. S.7, M.12, Q.12, U.7, V.7, V.12 and Z.7.

And the Honourable David Ronald White, Her Majesty's Minister of Water Supply for the State of Victoria, shall give the necessary directions herein accordingly.

TOM FORRISTAL
Clerk of the Executive Council

GEELONG WATERWORKS AND SEWERAGE TRUST

At the Executive Council Chamber, Melbourne, the
thirteenth day of July, 1982

PRESENT:

His Excellency the Governor of Victoria
Mr Mathews | Mrs Toner

CONSENT TO BORROWING \$771 000

Under the powers conferred by the Geelong Waterworks and Sewerage Act and all other powers enabling him in that behalf, His Excellency the Governor of the State of Victoria, by and with the advice of the Executive Council of the said State, hereby consents to the Geelong Waterworks and Sewerage Trust borrowing the sum of Seven hundred and seventy-one thousand dollars (\$771 000) in three separate loans of Two hundred and twenty-one thousand dollars (\$221 000), Five hundred thousand dollars (\$500 000) and Fifty thousand dollars (\$50 000) to meet the cost of water supply works and for the conversion of Loan Nos. 144, 203, 205, 206, 272 and 275.

And the Honourable David Ronald White, Her Majesty's Minister of Water Supply for the State of Victoria, shall give the necessary directions herein accordingly.

TOM FORRISTAL
Clerk of the Executive Council

GEELONG WATERWORKS AND SEWERAGE ACT 1958

At the Executive Council Chamber, Melbourne, the
thirteenth day of July, 1982

PRESENT:

His Excellency the Governor of Victoria
Mr Mathews | Mrs Toner

PROCLAMATION

Under the powers conferred by the Geelong Waterworks and Sewerage Act, and all other powers enabling him in that behalf His Excellency the Governor of the State of Victoria, by and with the advice of the Executive Council of the said State doth hereby proclaim that:

A. In relation to loan liability transferred from the State Rivers and Water Supply Commission to the Geelong Waterworks and Sewerage Trust in respect of the Headworks of the Bellarine water supply system—

- (i) for the purposes of sub-section (2) of section 57 the Geelong Waterworks and Sewerage Trust shall pay to the Treasurer a sum equal to five and one half per cent of the loan;
- (ii) for the purposes of sub-section (3) of section 57 the percentage rate per annum to be applied by the Treasurer as interest shall be five per cent of the balance of liability outstanding.

B. The day on which the matters herein shall commence shall be 1 July 1982.

And the Honourable David Ronald White, Her Majesty's Minister of Water Supply for the State of Victoria, shall give the necessary directions herein accordingly.

TOM FORRISTAL
Clerk of the Executive Council

HOUSING ACT 1958

At the Executive Council Chamber, Melbourne, the thirteenth day of July, 1982

PRESENT:

His Excellency the Governor of Victoria
Mr Mathews | Mrs Toner

DECLARATION OF PRIVATE STREETS AS PUBLIC HIGHWAYS WITHIN THE CITY OF KEILOR

Whereas pursuant to section 107 of the *Housing Act 1958* it is among other things enacted that where works have been carried out in accordance with an agreement for the full construction of any roads, pavements, culverts or drains made pursuant to the provisions of the said section 107 such roads, pavements, culverts or drains shall be under the care and management of the Municipality which shall be liable for the cost of any maintenance, repair, alteration or reconstruction thereof and the Governor in Council may by order published in the *Government Gazette* declare any road so constructed to be a public highway.

And whereas by Order dated 11 September 1979 the Governor in Council consented to an agreement between the Housing Commission and the City of Keilor regarding street and drainage construction in Copernicus Way, Adler Court, Allard Court, Willys Avenue, Ariel Court, Alvis Close and Belmont Avenue in the Keilor Downs-Pecatru Stage 4 Estate situate in the municipality of the City of Keilor and the carrying out of the works enumerated in the said Agreement.

And whereas the works of road pavements, culvert and drainage construction have now been carried out in accordance with the said Agreement between the Housing Commission and the City of Keilor.

Now therefore His Excellency the Governor of the State of Victoria by and with the advice of the Executive Council of the said State and in pursuance of the powers conferred by section 107 of the *Housing Act* and upon recommendation of the Housing Commission doth by this order declare the streets more particularly delineated and shown hatched on the plan hereunder to be absolutely dedicated to the public as Public Highways within the meaning of any law now or hereafter in force and that the Council of the Municipality in which the streets are situate shall hereafter be liable for all cost of any maintenance, repair, alteration or reconstruction thereof.

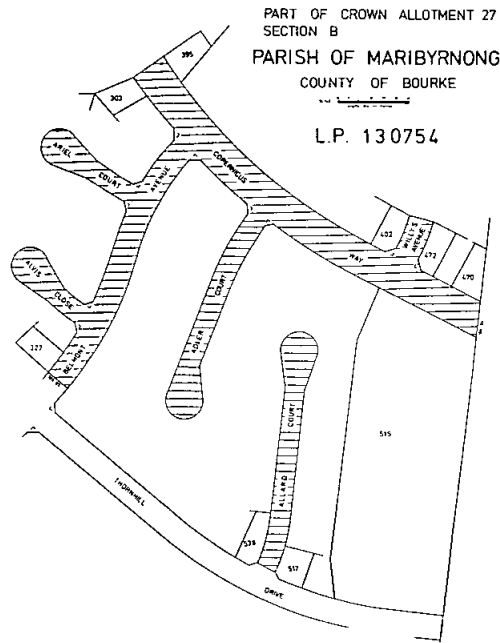

And the Honourable Ian Robert Cathie, Her Majesty's Minister of Housing for the State of Victoria, shall give the necessary directions herein accordingly.

TOM FORRISTAL
Clerk of the Executive Council

HOUSING ACT 1958

At the Executive Council Chamber, Melbourne, the thirteenth day of July, 1982

PRESENT:

His Excellency the Governor of Victoria
Mr Mathews | Mrs Toner

DECLARATION OF PRIVATE STREETS AS PUBLIC HIGHWAYS WITHIN THE CITY OF KEILOR

Whereas pursuant to section 107 of the *Housing Act 1958* it is among other things enacted that where works have been carried out in accordance with an agreement for the full construction of any roads, pavements, culverts or drains made pursuant to the provisions of the said section 107 such roads, pavements, culverts or drains shall be under the care and management of the Municipality which shall be liable for the cost of any maintenance, repair, alteration or reconstruction thereof and the Governor in Council may by order published in the *Government Gazette* declare any road so constructed to be a public highway.

And whereas by Order dated 9 October 1979 the Governor in Council consented to an agreement between the Housing Commission and the City of Keilor regarding street and drainage construction in Gillespie Road, Kambalda Circuit, Kurung Drive, Hedland Place, Goldsworthy Place, Pilbara Court, Grevillea Road, Penghana Place and Mica Place in the Keilor-Kings Park Stages 2, 3 and 4 Estate situate in the municipality of the City of Keilor and the carrying out of the works enumerated in the said Agreement.

And whereas the works of road pavements, culvert and drainage construction have now been carried out in accordance with the said Agreement between the Housing Commission and the City of Keilor.

Now therefore His Excellency the Governor of the State of Victoria by and with the advice of the Executive Council of the said State and in pursuance of the powers conferred by section 107 of the Housing Act and upon recommendation of the Housing Commission doth by this order declare the streets more particularly delineated and shown hatched on the plan hereunder to be absolutely dedicated to the public as Public Highways within the meaning of any law now or hereafter in force and that the Council of the Municipality in which the streets are situate shall hereafter be liable for all cost of any maintenance, repair, alteration or reconstruction thereof.

HOUSING ACT 1958

At the Executive Council Chamber, Melbourne, the thirteenth day of July, 1982

PRESENT:

His Excellency the Governor of Victoria
Mr Mathews | Mrs Toner

DECLARATION OF PRIVATE STREETS AS PUBLIC HIGHWAYS WITHIN THE CITY OF KEILOR

Whereas pursuant to section 107 of the Housing Act 1958 it is among other things enacted that where works have been carried out in accordance with an agreement for the full construction of any roads, pavements, culverts or drains made pursuant to the provisions of the said section 107 such roads, pavements, culverts or drains shall be under the care and management of the Municipality which shall be liable for the cost of any maintenance, repair, alteration or reconstruction thereof and the Governor in Council may by order published in the Government Gazette declare any road so constructed to be a public highway.

And whereas by Order dated 4 March 1979 the Governor in Council consented to an agreement between the Housing Commission and the City of Keilor regarding street and drainage construction in Aldershot Drive, Odessa Avenue, Tarella Drive, Wexford Court, Medina Road, Green Gully Close, Rason Court, Verden Place, Morley Court, Sorrell Court and Cadiz Place in the Keilor-Thornhill Stage 4 Estate situate in the municipality of the City of Keilor and the carrying out of the works enumerated in the said Agreement.

And whereas the works of road pavements, culvert and drainage construction have now been carried out in accordance with the said Agreement between the Housing Commission and the City of Keilor.

Now therefore His Excellency the Governor of the State of Victoria by and with the advice of the Executive Council of the said State and in pursuance of the powers conferred by section 107 of the Housing Act and upon recommendation of the Housing Commission doth by this order declare the streets more particularly delineated and shown hatched on the plan hereunder to be absolutely dedicated to the public as Public Highways within the meaning of any law now or hereafter in force and that the Council of the Municipality in which the streets are situate shall hereafter be liable for all cost of any maintenance, repair, alteration or reconstruction thereof.

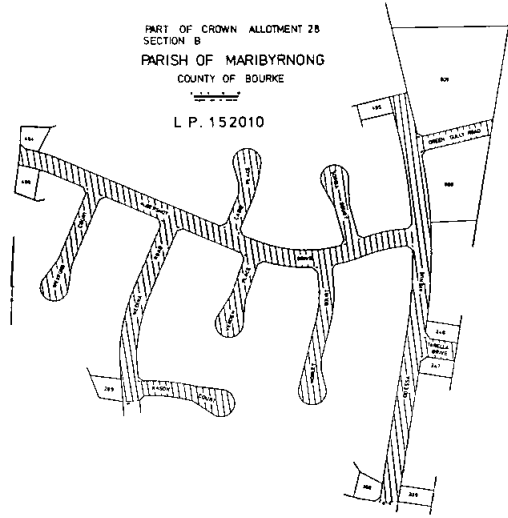
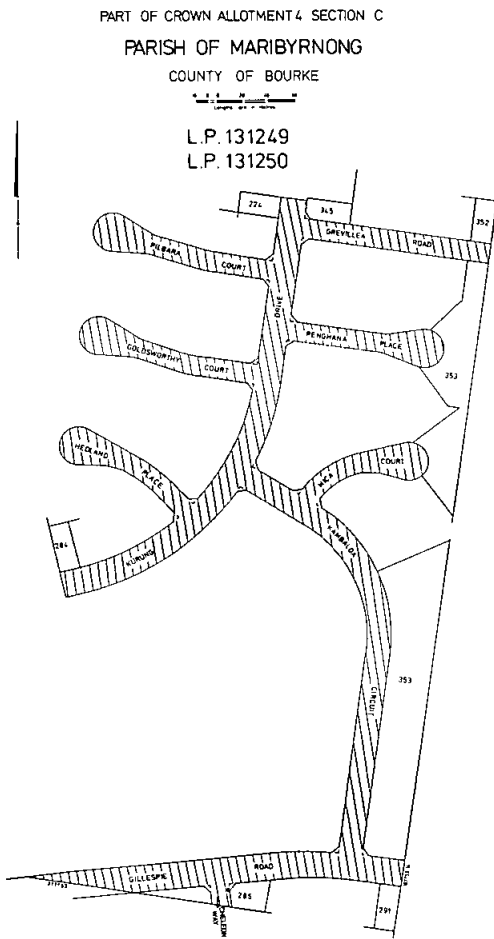

And the Honourable Ian Robert Cathie, Her Majesty's Minister of Housing for the State of Victoria, shall give the necessary directions herein accordingly.

TOM FORRISTAL
Clerk of the Executive Council

And the Honourable Ian Robert Cathie, Her Majesty's Minister of Housing for the State of Victoria, shall give the necessary directions herein accordingly.

TOM FORRISTAL
Clerk of the Executive Council

MILDURA IRRIGATION AND WATER TRUSTS ACT 1958

*At the Executive Council Chamber, Melbourne, the
thirteenth day of July, 1982*

PRESENT:

His Excellency the Governor of Victoria
Mr Mathews | Mrs Toner

PROCLAMATION

Under the powers conferred by the Mildura Irrigation and Water Trusts Act and all other powers enabling him in that behalf, His Excellency the Governor of the State of Victoria, by and with the advice of the Executive Council of the said State doth hereby proclaim that:

A. In relation to loans made to the Mildura Urban Water Trust—

- (i) for the purposes of sub-section (2) of section 131 the Mildura Urban Water Trust shall pay to the Treasurer a sum equal to five and one quarter per cent of the principal advanced;
- (ii) for the purposes of sub-section (2A) of section 131 the percentage rate per annum to be applied by the Treasurer as interest shall be five per cent of the balance of principal outstanding.

B. For the purposes of sub-section (1) of section 131A, the percentage rate per annum of interest exceeding which the Treasurer shall make certain payments to the Mildura Urban Water Trust shall be five per cent per annum.

C. The day on which the matters herein shall commence shall be 1 July 1982.

And the Honourable David Ronald White, Her Majesty's Minister of Water Supply for the State of Victoria, shall give the necessary directions herein accordingly.

TOM FORRISTAL
Clerk of the Executive Council

LATROBE VALLEY ACT 1958

*At the Executive Council Chamber, Melbourne, the
thirteenth day of July, 1982*

PRESENT:

His Excellency the Governor of Victoria
Mr Mathews | Mrs Toner

PROCLAMATION

Under the powers conferred by the Latrobe Valley Act and all other powers enabling him in that behalf, His Excellency the Governor of the State of Victoria, by and with the advice of the Executive Council of the said State doth hereby proclaim that:

A. In relation to loans made to the Latrobe Valley Water and Sewerage Board—

- (i) for the purpose of sub-section (3) of section 49 the Latrobe Valley Water and Sewerage Board shall pay to the Treasurer a sum equal to five and one half per cent of the principal advanced;
- (ii) for the purpose of sub-section (4) of section 49 the percentage rate per annum to be applied by the Treasurer as interest shall be five per cent of the balance of the principal outstanding.

B. In relation to any monies borrowed under the provisions of section 64 of the Latrobe Valley Act which incorporates sub-section (1) of section 304 of the Water Act the percentage rate per annum of interest exceeding which the Treasurer shall make certain payments to the Latrobe Valley Water and Sewerage Board shall be five per cent per annum.

C. The day on which the matters herein shall commence shall be 1 July 1982.

And the Honourable David Ronald White, Her Majesty's Minister of Water Supply for the State of Victoria, shall give the necessary directions herein accordingly.

TOM FORRISTAL
Clerk of the Executive Council

BUILDING SOCIETIES ACT 1976, No. 8966

*At the Executive Council Chamber, Melbourne, the
thirteenth day of July, 1982*

PRESENT:

His Excellency the Governor of Victoria
Mr Mathews | Mrs Toner

In accordance with the provisions of section 84 of the *Building Societies Act 1976*, His Excellency the Governor of the State of Victoria, by and with the advice of the Executive Council thereof, doth appoint:

ROBERT WILLIAM MCINTYRE FARROW and
PHILIP COMAN

to be Members of the Building Societies Advisory Committee for the period to 15 January 1983 and doth hereby determine that each of the members other than those who are officers of the Public Service of the State of Victoria shall be paid a fee at the rate of \$1370 per annum.

And the Honourable Ian Cathie, Her Majesty's Minister of Housing for the State of Victoria, shall give the necessary directions herein accordingly.

TOM FORRISTAL
Clerk of the Executive Council

SUPERANNUATION ACT 1958, No. 6386

*At the Executive Council Chamber, Melbourne, the
thirteenth day of July, 1982*

PRESENT:

His Excellency the Governor of Victoria
Mr Mathews | Mrs Toner

In accordance with the provisions of the *Superannuation Act 1958*, No. 6386, His Excellency the Governor of the State of Victoria by and with the advice of the Executive Council thereof doth by this Order—

- (a) appoint Geoffrey Peter Ballard, B.A., B.Ec., A.A.S.A., pursuant to the provisions of section 51 of the said Act to be a member of the State Superannuation Board for the period ending 23 December 1985; and
- (b) determine pursuant to the provisions of section 55 of the said Act that the said Geoffrey Peter Ballard shall be entitled to be paid remuneration at the rate of \$3089 per annum while he continues to perform the duties of a member of the State Superannuation Board.

And the Honourable Robert Allen Jolly, Her Majesty's Treasurer for the State of Victoria, shall give the necessary directions herein accordingly.

TOM FORRISTAL
Clerk of the Executive Council

SEWERAGE DISTRICTS ACT 1958

*At the Executive Council Chamber, Melbourne, the
thirteenth day of July, 1982*

PRESENT:

His Excellency the Governor of Victoria
Mr Mathews | Mrs Toner

PROCLAMATION

Under the powers conferred by the Sewerage Districts Act and all other powers enabling him in that behalf, His Excellency the Governor of the State of Victoria, by and with the advice of the Executive Council of the said State doth hereby proclaim that:

A. In relation to loans made to the Sewerage Authorities named in the First and Second Schedule hereunder:

FIRST SCHEDULE

Sewerage Authorities

Anglesea	Mildura Shire
Ararat	Mildura
Bacchus Marsh	Minyip
Ballan	Mirboo North
Barwon Heads	Mornington
Beaufort	Mt. Eliza
Beechworth	Myrtleford
Bellarine	Nagambie
Benalla	Narracan Shire
Bendigo	Nathalia
Birchip	Numurkah
Camperdown	Pakenham
Casterton	Paynesville
Castlemaine	Port Fairy
Charlton	Portland
Chiltern	Queenscliffe
Cobram	Rainbow
Cohuna	Robinvale
Colac	Rochester
Coleraine	Romsey
Cranbourne Shire	Rosedale
Creswick	Rupanyup
Dandenong	Sale
Daylesford	Sea Lake
Dimboola	Serviceton
Donald	Shepparton
Dromana—Rosebud	Springvale/Noble Park
Echuca	Stawell
Frankston	Strathmerton
Gisborne	Swan Hill
Hamilton	Terang
Hastings	Tongala
Heathcote	Torquay
Heytesbury Shire	Traralgon
Heywood	Upper Yarra
Horsham	Wangaratta
Hurstbridge	Waranga Shire
Jeparit	Warracknabeal
Kaniva	Warrnambool
Kyabram	Willaura
Kyneton	Wodonga
Lang Lang	Wonthaggi
Lilydale	Woodend
Mallacoota	Wycheproof
Maryborough	Yackandandah
Melton	Yarrawonga

SECOND SCHEDULE

Sewerage Authorities

Alexandra	Maffra
Apollo Bay	Moe
Bairnsdale	Mansfield Shire
Ballarat	Mooroopna
Bright	Morwell
Broadford	Mt. Beauty
Churchill	Murtoa
Corryong	Nhill
Cowes	Orbost
Drouin	Riddells Creek
Edenhope	Rutherglen Shire
Euroa	St. Arnaud
Foster	Seymour
Halls Gap	Sunbury
Healesville	Tallangatta
Heyfield	Tatura
Inverloch	Toora
Kerang	Warragul
Kilmore	Winchelsea
Korumburra	Yallourn North
Lakes Entrance	Yarram
Leongatha	Yea
Lorne	

- (i) for the purposes of sub-section (1) of section 75 an Authority shall pay to the Treasurer a sum equal to five and one half per cent of the principal advanced;
- (ii) for the purposes of sub-section (2) of section 75 the percentage rate per annum to be applied by the Treasurer as interest shall be five per cent of the balance of principal outstanding.

B. For the purposes of sub-section (1) of section 72, the percentage rate per annum of interest exceeding which the Treasurer shall make certain payments to the Sewerage Authorities named in the First and Second Schedule hereto shall be five per cent per annum.

C. The respective days on which the matters herein shall commence shall be—

- (i) In respect of the authorities named in the First Schedule hereto 1 October 1982.
- (ii) In respect of the authorities named in the Second Schedule hereto 1 January 1983.

And the Honourable David Ronald White, Her Majesty's Minister of Water Supply for the State of Victoria, shall give the necessary directions herein accordingly.

TOM FORRISTAL
Clerk of the Executive Council

WATER ACT 1958

At the Executive Council Chamber, Melbourne, the
thirteenth day of July, 1982

PRESENT:

His Excellency the Governor of Victoria
Mr Mathews | Mrs Toner

PROCLAMATION

Under the powers conferred by the Water Act and all other powers enabling him in that behalf, His Excellency the Governor of the State of Victoria, by and with the advice of the Executive Council of the said State doth hereby proclaim that:

A. In relation to loans made to the Waterworks Trusts or Local Governing Bodies named in the First and Second Schedule hereunder:

FIRST SCHEDULE

Waterworks Trusts	Metung
Aireys Inlet	Mirboo North
Shire of Ararat	Maryborough
Ballan	Myrtleford
Balmoral	Nagambie
Barnawartha	Shire of Nathalia
Beaufort	Shire of Numurkah
Benalla	Peterborough
Suninyong	Portland
Cann River	Port Fairy
Charlton	Romsey
Chiltern	Rosedale
Cobram	Rushworth
Cohuna	Swan Hill
Colac	Shire of Tallangatta
Daylesford	Traralgon
Dookie	Shire of Tullaroop
Shire of Dundas	Wangaratta
Echuca	Warracknabeal
Forrest	Wodonga
Gisborne	Woodend
Shire of Glenelg	
Goornong	Local Governing Bodies
Hamilton	Beechworth Shire Council
Heathcote	Bet Bet Shire Council
Shire of Heytesbury	Camperdown Town Council
Heywood	Creswick Shire Council
Horsham	Korong Shire Council
Hurstbridge	Kyabram Water Authority
Shire of Kaniva	Sale City Council
Shire of Kyneton	Stawell Town Council
Lancefield	Talbot and Clunes Shire Council
Lexton	Walpeup Shire Council
Mallacoota	Warrnambool City Council
Melton	Warrnambool Shire Council
Merrigum	

SECOND SCHEDULE

<i>Waterworks Trusts</i>	Mortlake
Alberton-Port Albert	Morwell
Alexandra	Mount Beauty
Apollo Bay	Mount Macedon
Avenel	Mt. Rouse, Shire of
Avoca Township	Moyhu
Axedale	Murchison
Bairnsdale	Murrayville
Bannockburn	Murtoa
Bealiba	Neerim South
Boolara	Nhill
Boort	Noojee
Briagalong	Omeo
Bridgewater	Orbost
Bright	Paynesville
Broadford	Poowong, Loch and Nyora
Bruthen	Pyalong
Buchan	Redband
Bungaree and Wallace	Riddells Creek
Colbinabbin	Rochester
Coleraine and Casterton	Rokewood
Corryong	Rutherglen, Shire of
Cudgewa	Seaspray
Deakin, Shire of	Seymour
Devenish	Shepparton Urban
Donald	Skenes Creek
Drouin	Skipton
Dumbalk	Smythesdale-Scarsdale
Elmore	Springhurst
Erica	St. Arnaud
Euroa	Stawell, Shire of
Fish Creek	Stratford
Foster	Sunbury
Gellibrand	Swifts Creek
Gembrook, Cockatoo and	Tatura
Emerald	Thornton
Glenrowan	Thorpdale
Goorambat	Toora
Healesville	Trafalgar
Heyfield	Trentham
Inverloch	Tungamah, Shire of
Katamatite	Tyers and Glengarry
Kerang	Underbool
Kiewa	Violet Town
Kilmore and District	Walwa
Koroit	Warburton
Korumburra	Warragul
Kowree, Shire of	Westernport
Lakes Entrance	Whitfield
Landsborough	Winchelsea
Lang Lang	Woods Point
Learmonth	Woori Yallock-Launching
Leongatha	Place
Lindenow	Yackandandah
Linton	Yallourn North
Lismore and Derrinalum	Yarragon
Little River	Yarra Junction
Longwood	Yarram
Lorne	Yarrowonga Urban
Macedon	Yea
Maffra	
Malmsbury	<i>Local Government Bodies</i>
Mansfield, Shire of	Ararat City Council
Marysville	Bacchus Marsh Shire
Meeniyah	Council
Moe	Ballarat Water
Mooroopna	Commissioners

No. 71—52290/82—3

(i) for the purposes of sub-section (1) of section 289 an Authority shall pay to the Treasurer a sum equal to five and one quarter per cent of the principal advanced;

(ii) for the purposes of sub-section (2) of section 289 the percentage rate per annum to be applied by the Treasurer as interest shall be five per cent of the balance of principal outstanding.

B. For the purposes of sub-section (1) of section 304, the percentage rate per annum of interest exceeding which the Treasurer shall make certain payments to the Waterworks Trusts and Local Governing Bodies named in the First and Second Schedule hereto shall be five per cent per annum.

C. The respective days on which the matters herein shall commence shall be—

(i) In respect of the authorities named in the First Schedule hereto 1 October 1982.

(ii) In respect of the authorities named in the Second Schedule hereto 1 January 1983.

And the Honourable David Ronald White, Her Majesty's Minister of Water Supply for the State of Victoria, shall give the necessary directions herein accordingly.

TOM FORRISTAL
Clerk of the Executive Council

LANDS DEPARTMENT NOTICES

APPROACHING LAND SALES

Sale of Crown Land, will be held at the under-mentioned places and dates, viz.:

	No. of Gazette
Kerang—Thursday, 15 July 1982	40
Shepparton—Friday, 20 August 1982	67
Warrandyte—Saturday, 7 August 1982	57

PROPOSED REVOCATION OF TEMPORARY RESERVATION OF LAND BY ORDER IN COUNCIL

In pursuance of the provisions of section 10 of the *Crown Land (Reserves) Act 1978*, notice is hereby given that it is the intention of the Governor in Council to revoke the temporary reservation of land by Order in Council hereunder referred to, viz.:

PURRUMBETE NORTH (WEERTE)—The temporary reservation by Order in Council of 30 September 1958 of 3313 square metres of land in the Parish of Purrumbete North as a site for Public Hall, revoked as to part by Order of 4 April 1978, so far as the balance thereof containing 2716 square metres, is concerned—(P.100(2) (Rs.7760).

QUEENSTOWN—The temporary reservation by Order in Council of 29 September 1890 of 3237 square metres of land in the Township of Queenstown as a site for a State School, revoked as to part by Order of 23 March 1914, so far as the balance thereof containing 2428 square metres, is concerned—(Q.22(*) (Rs.6730).

WUK WUK—The temporary reservation by Order in Council of 31 October 1908 of 8094 square metres of land in the Parish of Wuk Wuk (in section B) as a site for a State School—(C.39972).

R. A. MACKENZIE
Minister of Lands

Department of Crown Lands and Survey
Melbourne

Regulations

JOHNSTONE'S CREEK FLORA RESERVE, PARISHES
OF KENTBRUCK AND MOUZIE

I, Roderick Alexander Mackenzie, Her Majesty's Minister of Lands for the State of Victoria, pursuant to the provisions of section 13 of the *Crown Land (Reserves) Act 1978*, do hereby apply Regulations Nos. 1, 2 (a) to (i) (inclusive) and 3 (a), (b) and (c) made on 21 June 1982 (see *Government Gazette* dated 23 June 1982) for or with respect to the Crown land in the Parish of Kanawinka temporarily reserved for Preservation of Species of Native Plants, to the land in the Parishes of Kentbruck and Mouzie temporarily reserved for Preservation of Species of Native Plants by Order in Council of 27 October 1981 (see *Government Gazette* dated 4 November 1981)—(Rs.11884).

Given under my hand at Melbourne on 6 July 1982

R. A. MACKENZIE
Minister of Lands

Regulations

HAMILTON SHOW GROUNDS RESERVE

I, Roderick Alexander Mackenzie, Her Majesty's Minister of Lands for the State of Victoria, in pursuance of the powers conferred on me by section 13 of the *Crown Land (Reserves) Act 1978*, do hereby make the following Regulations for or with respect to the Crown land in the Township of Hamilton, Parish of Hamilton North temporarily reserved as a site for Public Purposes (Show Grounds, Public Recreation and Camping purposes) by Order in Council of 26 October 1976 (see *Government Gazette* dated 3 November 1976) and hereinafter referred to as the "Reserve".

The Reserve has been placed under the control of a Committee of Management (hereinafter referred to as the "Committee") with full power and authority to enforce these Regulations.

REGULATIONS

1. The Reserve shall be open to the public from sunrise to sunset, free of charge except on such days as the Reserve may be set apart for fêtes, sports, shows, displays, conventions or amusements, on any of which occasions an admission fee may be charged.

2. The Committee shall have the power to allow any club, association, person, society or any organization, the use of any portion of the Reserve for the purpose of holding entertainment performances, shows or sports, subject to the payment of such fees and on such terms as it may deem to be reasonable and consistent with these Regulations and to authorize any club association, society, or person, to make a charge for admission thereto as hereinbefore provided in these Regulations.

3. No person shall—

- (a) Enter or remain in the Reserve who may offend against decency as regards dress, language, or conduct, or who may behave in a disorderly, unseemly, or offensive manner, or create or take part in any disturbance;
- (b) Enter or remain in the Reserve whilst in a state of intoxication;
- (c) Use indecent or offensive language in the Reserve;
- (d) On behalf of any Club or Organization or in that person's own right offer any commodity whatsoever for sale in the reserve without the consent of the committee first obtained in writing;
- (e) Obstruct, hinder, or interfere with any person employed at the Reserve;
- (f) Climb, jump, get on or over any of the gates or fences in or around the Reserve, or stick bills or advertisements, or cut names thereon, or in any way damage or injure any of the buildings, furniture, or fittings, gates, fences, seats, or other structures in the Reserve;
- (g) Interfere with, break, or damage in any way any of the trees, shrubs, or plants, or pluck any of the flowers, or walk on the beds or borders in the Reserve;
- (h) Leave or deposit any bottles, broken glass, paper, orange peel, banana skins, refuse or rubbish

whatsoever therein, nor roll or throw stones or missiles of any kin therein or leave anything therein that might injure any person;

- (i) Light a fire in the Reserve except at such places as are set apart for the purpose by the Committee;
- (j) Carry or discharge any firearms or air guns in the Reserve or shoot, snare, or destroy any game or birds therein without the consent of the Committee first obtained;
- (k) Bet publicly in the Reserve without the consent of the Committee;
- (l) Spit or expectorate on the paths or on any structure or erection in the Reserve;
- (m) Erect any building, tent or structure or camp on any portion of the Reserve without permission in writing of the Committee first obtained, and then only under such conditions as may be determined by the said Committee;
- (n) Bring into the Reserve any dog unless controlled by a chain or cord without the permission of the Committee;
- (o) Do anything whatever in the Reserve for the purpose of making money without the consent in writing of the Commission first obtained.

Every person infringing this Regulation in any respect shall be liable to expulsion from the Reserve in addition to any other penalty to which such person may be liable.

4. For the purpose of maintaining good order, any person authorized by the Committee may refuse admission to any person to the Reserve.

5. No person shall remain in the Reserve at any time when lawfully directed by any officer or employee of the Committee to leave the same.

6. Any Person or Organization renting or hiring any stand, building, erection, or enclosure on the occasion of any sport, fetes, or holiday amusements may be required to deposit a sum which the Committee may at any time determine by way of guarantee that due care shall be taken of such stand, building, erection, or enclosure, and such Committee in its absolute discretion may make good any damage or injury or loss from the sum of money deposited by way of guarantee, and all persons so renting or hiring shall abide by these Regulations and by any order given by the Committee.

7. No person shall take or put or allow to be taken or put in the Reserve any horses, cattle, sheep, goats, pigs or other animals, or being the owner or having the possession, care custody, control or supervision thereof, shall suffer or allow such horses, cattle, sheep, goats, pigs, or other animals to be in or graze or wander upon the Reserve without the permission in writing of the Committee first obtained.

8. The owner of any horses, cattle, sheep, goats, pigs, or other animals that are found wandering upon any part of the Reserve shall be guilty of an offence against these Regulations.

9. All animals and all poultry entering the Reserve must be under proper control, and the owner of any animal or poultry that causes damage within the Reserve shall be responsible therefor.

10. No person shall on any portion of the Reserve cause or permit any outcry, sound or noise to be emitted from an amplifier, loud speaker, public address system or like instrument without first obtaining the written permission of the Committee and such permission may be granted subject to such terms, conditions and restrictions as may be imposed by the Committee.

11. No person shall camp in the Reserve except in the part or parts thereof which are set apart for such purposes by the Committee and then only on the payment of such fees and subject to such conditions as are determined by the Committee.

12. The Committee may allow any club, association or organization or person the use of the Reserve or any portion thereof for the purpose of holding football, cricket, or other matches, fetes, carnivals, entertainments, musical performances, conventions, fairs, shows or sports, or for playing football, cricket, soccer, hockey or other athletic games, or for athletic training or other physical recreation, subject to payment of such fees and on such terms and conditions as it may deem reasonable and consistent with these Regulations.

13. No club, association, or person shall hold or take part in any organized entertainment, performance, show, or ceremony in any part of the Reserve without the written authority of the Committee first obtained.

14. No club or association of any kind having for its object physical recreation, or any member or members of any club or association, nor any other person shall play, practise, train, or engage in any game or sport or athletic exercise within the Reserve without the permission in writing of the Committee first obtained, unless any person is at the time of playing a member of any club which is duly authorized by the said Committee to play in the Reserve at such time.

15. No person shall enter any building in the Reserve without the permission of the Committee and any person having entered such building shall leave the same on being requested so to do by any member of the Committee or by any member of the Police Force or by any Bailiff of Crown lands—(Rs.3575).

Given under my hand at Melbourne, 6 July 1982

R. A. MACKENZIE
Minister of Lands

Every person who contravenes or fails to comply with these Regulations shall be liable to the penalties prescribed in section 13 of the *Crown Land (Reserves) Act 1978*.

TENDERS

PUBLIC WORKS DEPARTMENT

Tenders are invited for the purposes indicated hereunder and will be received at 2 Treasury Place, Melbourne, 3002, until **TWO** p.m. on dates shown.

Tenders must be addressed to the Minister of Public Works with the envelope endorsed "Tender for

". Hand-delivered tenders must be placed in the Department's tender box in the foyer, Ground Floor, 2 Treasury Place, Melbourne.

Tenders documents are available from the Contracts Office, Room 29, 2 Treasury Place, Melbourne and where indicated, at offices of Inspectors of Works.

*Tenders for works identified with star (★) will only be considered from Contractors qualified for repairs and painting works. Any Tenderers wishing to qualify may obtain the application form from the Contracts Office.

Tuesday, 27 July 1982

Building, Electrical and Mechanical Works

ARDOCH—Alterations to woodwork room, High School, Educational Village.

★ASCOT VALE WEST—Internal and external cyclic maintenance, Primary School.

★BALLAM PARK—External repairs and painting, Primary School.

★BUCKLEY PARK—Internal and external cyclic maintenance, High School.

★COOMOORA—External repairs and painting, Primary School.

HEATHMONT EAST—Staff administration upgrade, Primary School.

★MALLACOOTA—Internal renovations and replacement of roofing, Residence. (W.O., Bairnsdale.)

★MONBULK—(Re-advertisement)—External and part internal renovations, High School No. 8065.

★OAKWOOD PARK—External repairs and painting, Primary School.

★SPRINGVALE—External repairs and painting, Primary School.

Site Works

DONCASTER EAST—Siteworks—Proposed carpark area, Primary School.

MOE—Pavement repairs and drainage improvements, Primary School No. 4740. (W.O., Bairnsdale and Traralgon.)

Miscellaneous

ALBERT PARK—Maintenance cleaning (three years) period 16 August 1982 to 31 July 1985.

MELBOURNE—Supply of sheet steel furniture, Titles Office.

MILDURA—Supply of television equipment, Sunraysia TAFE College.

PORT WELSHPOOL—Hire of mobile crane, Crane Hire. (W.O., Port Welshpool.)

SOUTH MELBOURNE—Maintenance cleaning, period 9 August 1982 to 31 July 1985, Central Regional Office.

WODONGA—Maintenance cleaning, Police Station. (W.O., Wodonga.)

Tuesday, 3 August 1982

Building, Electrical and Mechanical Works

★BAIRNSDALE—(Re-advertisement)—Internal and external renovations, State Offices. (W.O., Bairnsdale.)

BURWOOD—Staff administration, home economics, fabrics and cyclic maintenance, Technical School.

★CARRUM—(Re-advertisement)—External repairs and painting, Primary School.

DOVETON WEST—Fire reinstatement/library conversion, staff and administration upgrade, art/craft conversion, Primary School.

MELBOURNE—Alterations to first and second floors, Spring Street.

SOUTH MELBOURNE—Mental retardation division central district office, alterations, Coventry Street.

★ST. ARNAUD—(Re-advertisement)—External repairs and painting, High School. (W.O., Ballarat.)

TRARALGON—(Re-advertisement)—Air-conditioning of a police station, Police Station. (W.O., Traralgon.)

THOMASTOWN—Connection to sewer at Main Street, High School and West Primary School No. 4999.

WARRANTYTE SOUTH—Installation of proposed septic system and sand filter and the reconnection of existing fixtures, Primary School.

Miscellaneous

BENDIGO—Supply of materials, handling equipment, Loddon Valley TAFE College.

BENDIGO—Supply of compressed air equipment, Loddon Valley Regional College of TAFE.

DENNINGTON—Maintenance cleaning, period 1 September 1982 to 31 August 1985, Traffic Operations Group. (W.O., Warrnambool.)

SANDRINGHAM—Maintenance cleaning, period 1 September 1982 to 31 August 1985, Court House.

TERANG—Maintenance cleaning, period 1 September 1982 to 31 August 1985, Police Station. (W.O., Camperdown.)

THOMASTOWN—Maintenance cleaning, period 1 September 1982 to 31 August 1985, Police Station.

WONTHAGGI—Maintenance cleaning, period 1 September 1982 to 31 August 1985, Public Offices. (W.O., Korumburra.)

JACK SIMPSON, M.P.
Minister of Public Works

Public Works Department
Melbourne, 13 July 1982

**PRIVATE
ADVERTISEMENTS**

CITY OF ESSENDON

LOAN No. 152

*Notice of Intention to Borrow the Sum of \$200 000 for
Permanent Works and Undertakings*

Notice is hereby given that the Council of the City of Essendon proposes to borrow the principal sum of Two hundred thousand dollars (\$200 000) secured by a charge over the general rates of the municipality, such sum to be raised by the grant of a mortgage in accordance with the provisions of the *Local Government Act 1958*.

1. The maximum rate of interest that may be paid is 17.5 per cent per annum.

2. The purpose for which the loan is to be applied is:

	\$
C.R.B. Works Contribution	80 300
Seyern Street Footpath	10 000
Nicholson Street Footpath	6 000
(Brewster Street to Raleigh Street)	
St. Leonards Road Reconstruction	70 200
(No. 79 Ferguson Street)	
Aberfeldie Street Reconstruction	33 500
(Buckley Street to Alma Street)	
	200 000

3. The period of the loan shall be fifteen (15) years.

4. The moneys borrowed shall be repayable by providing out of the municipal fund thirty (30) half yearly instalments of approximately \$19 037.18 each including principal and interest on 1 March and 1 September each year during the currency of the loan. The first instalment shall be repayable on 1 March 1983.

5. Such moneys shall be repayable to The Office of the Local Authorities Superannuation Board, Melbourne.

The plans and specifications and the estimate of the cost of the proposed works and a statement showing the proposed expenditure of the moneys to be borrowed are open for inspection at the office of the Council of the City of Essendon.

At Essendon Civic Centre corner Pascoe Vale Road and Kellaway Avenue, Moonee Ponds, Victoria.

Civic Centre, Moonee Ponds

1432 B. C. BEATTIE, City Manager/Town Clerk

CITY OF ESSENDON

LOAN No. 153

*Notice of Intention to Borrow the Sum of Two Hundred
and Sixty-eight Thousand Dollars for Permanent Works
and Undertakings*

Notice is hereby given that the Council of the City of Essendon proposes to borrow the principal sum of Two hundred and sixty-eight thousand dollars (\$268 000) secured by a charge over the general rates of the municipality, such sum to be raised by the grant of a mortgage in accordance with the provisions of the *Local Government Act 1958*.

1. The maximum rate of interest that may be paid is 17.5 per cent per annum.

2. The purpose for which the loan is to be applied is:

	\$
(a) Purchase of plant and machinery:	
one only double cabin 3 tonne tip truck	15 000
one only 3 tonne tip truck	13 000
one only 8 tonne mobile crane with winch and cabin	55 000
one only dual control auto street sweeper	85 000
	168 000
(b) part cost of erection of pavilion at Boeing Reserve	100 000
	268 000

3. The period of the loan shall be ten (10) years.

4. The moneys borrowed shall be repayable by providing out of the municipal fund twenty (20) half yearly instalments of approximately \$28 837.28 each including principal and interest on 1 February and 1 August each year during the currency of the loan. The first instalment shall be repayable on 1 February 1983.

5. Such moneys shall be repayable to The Commissioners of the State Bank of Victoria at the office of the said Commissioners, Melbourne.

The plans and specifications and the estimate of the cost of the proposed works and a statement showing the proposed expenditure of the moneys to be borrowed are open for inspection at the office of the Council of the City of Essendon.

At Essendon Civic Centre, corner Pascoe Vale Road and Kellaway Avenue, Moonee Ponds, Victoria

Civic Centre, Moonee Ponds

1433 B. C. BEATTIE, City Manager/Town Clerk

CITY OF KNOX

BY-LAW No. 35

Library By-Law

A By-Law of the City of Knox made under section 197 (1) of the *Local Government Act 1958* and numbered 35 for the purpose of:

- (a) regulating the management and control of library services provided by the Council jointly with the Eastern Regional Libraries Committee;
- (b) imposing penalties not exceeding \$100 for breaches of this By-Law.

Pursuant to the powers conferred by the *Local Government Act 1958* the Mayor, Councillors and Citizens of the City of Knox order as follows:

A. Title

1. This By-Law shall be known as the Library By-Law.

B. Operation

2. This By-Law shall apply to and have operation throughout the whole of the municipal district of the City of Knox.

C. Definitions

3. In this By-Law unless the context or subject matter otherwise indicates or requires—

- (a) "Book" includes any and every book, magazine, newspaper, pamphlet, music score, gramophone record, video recording, audio-tape recording, picture, print, photograph, map, chart, plan, film, slide, manuscript, toy, or any other article forming part of the contents of the library available for borrowing reference or perusal whether or not the property of the City of Knox Council.
- (b) "Council" means the Council of the City of Knox.
- (c) "Committee" means the Eastern Regional Libraries Committee as constituted under an agreement dated 1 October 1967 and any subsequent agreement amending or replacing it for library services between the Cities of Knox, Ringwood, Croydon and the Shires of Healesville, Sherbrooke and Upper Yarra.
- (d) "Library Services" means all the library facilities, resources, and activities provided by the Council and the Committee.
- (e) "Librarian" means the person for the time being in charge of the library service generally, or any section or portion thereof.
- (f) "Library" means all or any library outlet under the management and control of the Council or the committee under the said agreement and includes without limiting the generalities of the foregoing, all buildings or portions thereof, mobile libraries, and other areas, facilities and vehicles used in connection with the provision of the library service.
- (g) "Member" means a person or institution holding a current and valid membership card issued in accordance with this By-Law.

- (h) "Membership Card" means a current and valid card issued to a member by the Librarian in accordance with this By-Law as an authority to borrow books.
- (i) "Library Service Area" means the whole of the municipal district of the Cities of Knox, Ringwood and Croydon, and the Shires of Healesville, Sherbrooke and Upper Yarra.
- (j) "User" means any person making use of the library service.

D. Administration

4. The Librarian is responsible for the management and administration of the library service in accordance with the policies and directions of the committee as shall be determined from time to time.

5. Any person using the library service shall obey the lawful directions of the Librarian.

E. Access and Use

6. The committee shall determine the hours the library will be open for use by the public. These hours will be prominently displayed in the library and advertised by other methods as shall be determined from time to time.

7. Subject to the provisions of this By-Law any person shall have access to the library for the purpose of using the services and facilities on the premises during the hours it is open to the public.

8. Subject to the provisions of this By-Law, members shall have access to the library for the purpose of borrowing books and their representatives will be admitted for that purpose at the discretion of the Librarian.

9. No charges shall be made for the registration of members, except as provided in Clauses 12 (e) and 12 (f) of this By-Law, or for the borrowing of books for use on or off the premises, or for reference and information services, including those provided from computer data bases, provided that charges may be made for reservation of books, including those borrowed from other libraries on behalf of a member, or for photo or other copies which will remain the property of the member.

10. No person other than library staff or persons duly authorized by the Librarian or the Council or the committee shall enter or remain in the Library except during the hours of opening.

F. Membership

11. Subject to Clause 15 of this By-Law members shall be entitled to borrow books from the library.

12. Subject to the approval of the Librarian the following persons shall be eligible to become members:

- (a) Any ratepayer of the City of Knox or of the member municipalities of the committee.
- (b) Any resident of the library service area.
- (c) Any non-resident who is employed in or who attends an educational institution in the library service area.
- (d) Any person eligible to join another Victorian subsidised public library.
- (e) Any temporary visitor to the library service area from outside Victoria. These persons may be admitted to temporary membership for a period to be determined by the Librarian and may be required to pay a monetary deposit to be determined by the committee from time to time.
- (f) Any Victorian resident who does not qualify for membership under (a)-(d) above on payment of an annual fee to be determined from time to time by the committee.

13. All persons in the categories listed in clause 12 of this By-Law shall provide such proof of eligibility as shall be required by the Librarian.

14. Institutional Membership may be extended to any association, society, institution, business or agency at the discretion of the Librarian, provided that such body's premises, predominant area of service or activity, or normal place of meeting is within the library service area.

15. Persons wishing to borrow books shall:

- (a) complete and sign the appropriate application form, which shall include an undertaking to comply with the provisions of this By-Law;
- (b) satisfy the Librarian that he or she is eligible for membership.

16. Persons under the age of 18 may be required by the Librarian to have a guarantee to make good the loss or damage to any book whilst in the members' use or possession signed by an adult.

17. Every member on being issued with a membership card shall:

- (a) be responsible for the custody of the card;
- (b) produce the card to the Librarian whenever a book is borrowed;
- (c) report the loss of the card to the Librarian immediately such loss is discovered;
- (d) notify any change of address to the Librarian;
- (e) surrender the card to the Librarian on ceasing to be eligible for membership.

18. The Librarian may suspend or cancel the membership of any member who habitually retains books beyond the loan period or who habitually loses or damages books.

19. Membership shall be current for a period of three years unless previously surrendered or cancelled. Persons whose membership has lapsed may be required by the Librarian to re-register before borrowing books.

20. Membership cards are not transferrable.

G. Conditions of Borrowing

21. The committee shall make rules from time to time stating the maximum number of books which may be borrowed at any one time.

22. The time allowed for retaining a book shall be thirty (30) days, and the date for return of each book shall be clearly indicated to the member.

23. A member is responsible for the safe care of every book borrowed on his or her membership card and for its return to the library by the due date.

24. A member may be required to pay a charge for retaining a book beyond the time allowed. The amount of such charge shall be advertised by notice in a manner to be determined by the committee. The Library shall have no obligation to send any notice of charges incurred and failure to send such notice shall be no excuse for non-payment of such charges. Liability incurred by a member under this clause shall be discharged before any other book is issued.

25. A member may apply by telephone, post or in person for extension of the time allowed for retaining a book by describing the book in such terms as fully identify it to the Librarian. Such extension will only be granted if the original loan period has not expired or the book has not been reserved by another member.

26. Any book in the lending stock of the library may be reserved for a member on completion of a form prescribed by the Librarian. The Librarian will notify the member when the book is available. The member may be required to pay the cost of postage involved.

27. A member may recommend that consideration be given to the purchase of any book which is not in the stock of the library, or may request the Librarian to borrow a book from another library for him or her. A fee which shall be determined from time to time by the committee may be levied where a book is borrowed from another library.

28. Where a book is designated for reference use only, it shall not be borrowed except at the discretion of the Librarian.

29. A member is responsible for reporting to the Librarian any damage discovered in any book on loan to him or her. This damage shall be reported at the time of issue or immediately on return.

30. If a book is lost or damaged beyond repair, or it is stolen from a member he or she shall replace it or pay to the committee the full replacement value of such books plus such amount for processing costs as shall be determined by the committee from time to time.

31. Additional charges to be determined from time to time by the committee shall be made for the loss or damage of membership cards, library stationery or other items issued with a book. These charges will be displayed by notice in the library.

32. No book shall be deemed to have been returned to the library unless it has been handed to the Librarian, or left in a place or receptacle designated for the return of books, or despatched to the library by post or by a means previously approved by the Librarian.

33. The Committee may take such action as it deems necessary for the recovery of a book or the value thereof at any time after the book becomes overdue.

34. Books may be lent at the discretion of the Librarian to other library services in accordance with the *Rules for Inter-Library Lending* issued by the Municipal Inter-Library Committee (Victoria).

35. Books stolen or lost shall remain the property of the committee although replaced or paid for.

H. Conduct in the Library

36. Users shall not behave in the library in such a manner as may, in the opinion of the Librarian, cause serious inconvenience or discomfort to any other person in the library.

37. The Librarian's permission is required to bring any animal, other than a guide dog accompanying a blind person into the library.

38. Users may eat, drink or smoke only in areas which may be designated for such purposes.

39. Users shall not wilfully or negligently break, damage or interfere with the library furniture or fittings.

40. Users shall not deface, mutilate or mark by writing or otherwise any part of any materials belonging to, or in the care of, the library service.

41. Users shall not misplace or hide books or any library records with the intention to withhold their use from others.

42. Users may bring into the library reading and writing materials, a handbag or briefcase, an invalid's chair or baby carriage. Large bags or parcels, or shopping jeeps may be left in designated areas while their owners are using the library. The council and the committee take no responsibility for loss or damage to any bag or other article so left.

Any container or receptacle brought into the Library shall be opened for inspection on the request of the Librarian as the user leaves the Library.

43. Persons may distribute or display handbills or literature, or deliver a public address in the Library only with the consent of the Librarian.

44. Users shall enter only those parts of the library open for public use, except with the permission of the librarian.

45. Users shall leave the library at the times fixed for closing the library or at the request of the Librarian.

I. Offences

46. Any person who commits an offence against this By-Law shall:

- (a) give his or her name and address to the Librarian if requested to do so; and
- (b) leave the library immediately upon being requested by the Librarian to do so.

47. Any person who commits an offence against this By-Law shall be liable to a penalty not exceeding \$100.

J. Users Rights

48. All users shall have access to all books in the library for consultation on the premises *except* that some books may be on restricted access because of rarity, physical condition, embargo on use set by donors, or by legislation. Persons under the age of 18 shall if restricted from using some section of the library by written direction of parent or guardian, be excluded from the definition of user for the purpose of this clause.

49. All members shall have access on equal terms to all lending collections for borrowing purposes but excluding for the purpose of this clause persons under the age of 18 if restricted by parental direction.

50. Every user may suggest to the Librarian that consideration be given to the purchase by the library service of any book which is not in the stock of the library.

51. Every user shall have the right to comment to the Librarian on the performance of the library service or on the interpretation of this By-Law, and through the Librarian to the council or committee. Complaints to the council or committee shall be made in writing.

52. Information including information held in files outside the library and in computer files required for membership registration purposes shall not be made available to outside enquirers except in response to a Court order, or be used by library staff for any purposes other than follow-up of unreturned books, or for statistical purposes. Membership and circulation statistics shall not be produced in such form as will identify individual members.

53. Circulation records and records relating to materials requested from the library shall not be kept after the current transaction is completed. Exceptions may be made with services such as household bound services where selection is done by library staff and the record of past reading is essential to the success of the service.

54. This By-Law shall come into operation on the day after the day of publication thereof in the *Government Gazette*.

Resolution for passing this By-Law No. 35 agreed to by the Council on 25 May 1982 and confirmed 6 July 1982.

The common seal of the Mayor, Councillors and Citizens of the City of Knox was hereunto affixed, in the presence of—

1503 (SEAL) H. R. LUPTON, Mayor
W. H. TEW, Councillor
TIM NEVILLE, Town Clerk

Town and Country Planning Act 1961 (Twelfth Schedule) CITY OF MILDURA PLANNING SCHEME

NOTICE THAT A PLANNING SCHEME HAS BEEN PREPARED AND IS AVAILABLE FOR INSPECTION

Amendment No. 53, 1982

Notice is hereby given that the City of Mildura in pursuance of its powers under the *Town and Country Planning Act 1961* has prepared a planning scheme for:

To include in the Ordinance a provision allowing the erection of a "country dwelling" on lots less than 4 hectares in area in the Agricultural "A" zone, subject to certain requirements.

A copy of the scheme has been deposited at the office of the Mildura City Council, Civic Buildings, Deakin Avenue, Mildura and at the office of the Department of Planning (Plan Inspection Section), 5th Floor, 235 Queen Street, Melbourne, and will be open for inspection during office hours by any person free of charge.

Any persons affected by the scheme are required to set forth in writing any submissions they may wish to make with respect to the scheme, addressed to the Town Clerk, City of Mildura, Civic Buildings, Deakin Avenue, Mildura by 14 August 1982 and to state whether they wish to be heard in respect of their submissions.

24 June 1982

1514 DAMIAN B. GOSS, Town Clerk and Chief Executive

Town and Country Planning Act 1961 (Twelfth Schedule) CITY OF SHEPPARTON—CITY OF SHEPPARTON PLANNING SCHEME 1953

NOTICE THAT A PLANNING SCHEME HAS BEEN PREPARED AND IS AVAILABLE FOR INSPECTION

Amendment No. 64, 1982

Notice is hereby given that the Council of the City of Shepparton, in pursuance of its powers under the *Town and Country Planning Act 1961*, has prepared a Planning Scheme for:

All land immediately south of Pine Road presently zoned Agricultural, including the land contained in Revocation Order No. 1 (Sherbourne Clinic).

A copy of the Scheme has been deposited at the office of the Council of the City of Shepparton, Municipal Offices, Civic Centre, Shepparton, and at the office of the Department of Planning (Plan Inspection Section), 5th Floor, 235 Queen Street, Melbourne, and will be open for inspection during office hours by any person free of charge.

Any persons affected by the Scheme are required to set forth in writing any submissions they may wish to make with respect to the Scheme, addressed to the Town Clerk, City of Shepparton, P.O. Box 989, Shepparton, by 14 August 1982, and to state whether they wish to be heard in respect of their submissions.

6 July 1982

1453

I. L. GILBERT, Town Clerk

Town and Country Planning Act 1961 (Twelfth Schedule)
CITY OF SHEPPARTON—CITY OF SHEPPARTON
PLANNING SCHEME 1953

NOTICE THAT A PLANNING SCHEME HAS BEEN PREPARED AND IS AVAILABLE FOR INSPECTION

Amendment No. 63, 1982

Notice is hereby given that the Council of the City of Shepparton, in pursuance of its powers under the *Town and Country Planning Act 1961*, has prepared a Planning Scheme for:

The northern side of High Street, west of Welsford Street, Shepparton.

A copy of the Scheme has been deposited at the office of the Council of the City of Shepparton, Municipal Offices, Civic Centre, Shepparton, and at the office of the Department of Planning (Plan Inspection Section), 5th Floor, 235 Queen Street, Melbourne, and will be open for inspection during office hours by any person free of charge.

Any persons affected by the Scheme are required to set forth in writing any submissions they may wish to make with respect to the Scheme, addressed to the Town Clerk, City of Shepparton, P.O. Box 989, Shepparton, by 14 August 1982, and to state whether they wish to be heard in respect of their submissions.

6 July 1982

1452

I. L. GILBERT, Town Clerk

CITY OF SPRINGVALE

Pursuant to section 535 (4) of the *Local Government Act 1958* (as amended) the Council of the City of Springvale resolved, at a meeting held on 28 June 1982, that the name of part of the following street as set out hereunder be changed.

Old Name—Chelsea Road.

New Name—Thames Promenade.

Location—Between Wells Road and Riverend Road, Bangholme.

1449

I. J. TATTERSON, Acting Town Clerk

Town and Country Planning Act 1961 (Twelfth Schedule)
BOROUGH OF PORT FAIRY—PORT FAIRY PLANNING
SCHEME 1959

NOTICE THAT A PLANNING SCHEME HAS BEEN PREPARED AND IS AVAILABLE FOR INSPECTION

Amendment No. 23, 1982

Notice is hereby given that the Council of the Borough of Port Fairy in pursuance of its powers under the *Town and Country Planning Act 1961* has prepared a planning scheme for the purpose of amending the provisions in respect to subdivision in the Agricultural Zone.

A copy of the Scheme has been deposited at the Borough Chambers, Bank Street, Port Fairy and at the office of the Department of Planning (Plan Inspection Section), 5th Floor, 235 Queen Street, Melbourne, and will be open for inspection during office hours by any person free of charge.

Any persons affected by the Scheme are required to set forth in writing any submissions they may wish to make with respect to the Scheme addressed to the Town Clerk, Borough of Port Fairy, P.O. Box 51, Port Fairy by 16 August 1982 and to state whether they wish to be heard in respect of their submissions.

1502

IAN C. PATIENCE, Town Clerk

SHIRE OF COBRAM

LOAN No. 71

*Notice of Intention to Borrow the Sum of \$100 000 for
Permanent Works and Undertakings*

Notice is hereby given that the Council of the Shire of Cobram proposes to borrow the sum of One Hundred Thousand Dollars secured by a charge over the general rates of the Municipality such sum to be raised by the grant of a mortgage in accordance with the provisions of the *Local Government Act 1958*.

1. The maximum rate of interest to be paid is 17.5 per cent per annum, payable by half yearly instalments on 17 January and August each year.

2. The purpose for which the loan is to be applied is: The partial liquidation of Loan No. 56 which was originally borrowed as Council's contribution to the Cobram Community Library and the purchase of various sundry plant.

3. The period of the loan shall be ten years.

4. The loan is to be liquidated by a sinking fund created by the investment per annum, pursuant to the provisions of Section 428A of the *Local Government Act 1958*.

5. Such moneys shall be repayable at the office of the Insurance Commissioner, State Insurance Office, 480 Collins Street, Melbourne in one sum on 17 August 1992.

The plans, specifications and estimate of the cost of the work referred to above and a statement showing the proposed expenditure of the moneys to be borrowed are open for inspection at the Council Offices, Station Street, Cobram.

1530

W. LENYSZYN, Shire Secretary

SHIRE OF EAST LODDON

LOAN No. 48

Notice of Intention to Borrow

Notice is hereby given that the Council of the Shire of East Loddon intends to borrow the sum of Nine thousand seven hundred dollars (\$9700) the moneys borrowed to be secured by a charge over the general rates of the municipality and raised by the grant of a mortgage in accordance with the provisions of the *Local Government Act 1958*.

(1) The maximum rate of interest that may be paid is 16.1 per cent per annum.

(2) The purpose for which the loan is to be applied is to liquidate the principal moneys owing on account of Loan No. 21.

(3) The period of the loan shall be 10 years.

(4) The moneys borrowed shall be repayable by providing out of the municipal fund twenty half-yearly instalments of \$991.65 each on 14 March and 14 September each year during the currency of the loan, the first instalment being payable on 14 March 1983.

(5) The moneys shall be repayable at the C.B.C. Savings Bank Limited, Melbourne.

Dated 14 July 1982

1472

T. J. RUDKINS, Shire Secretary

SHIRE OF FLINDERS

Old Name—Hamilton Street.

New Name—Osborne Street.

That section of Hamilton Street running between Dromana Parade and Seaview Avenue, Safety Beach and being the Southern boundaries of Plan of Subdivision No. 111834 and Lot 697 on Plan of Subdivision No. 11273 and being the Northern boundary of Lot 695 on Plan of Subdivision No. 11273 and the Northern boundary of the remaining portion of Lot 202 on Plan of Subdivision 5041, has been renamed Osborne Street.

Old Name—Buckley Street.

New Name—Evans Street.

That section of Buckley Street running between Dromana Parade and Seaview Avenue, Safety Beach and being the Southern boundary of Lot 214 on Plan of Subdivision No. 5041 and the Southern boundary of Lot 716 on Plan of Subdivision No. 11273 and the Northern boundaries of Plan of Subdivision Nos. 136108 and 134935, has been renamed Evans Street.

1436

SHIRE OF LOWAN

LOAN No. 38

Notice of Intention to Borrow the Sum of \$14 000 for Permanent Works and Undertakings

The Council of the Shire of Lowan seek approval to borrow the principal sum of \$14 000 secured by a charge over the general rates of the Municipality, such sum to be raised by the grant of a mortgage in accordance with the provisions of the *Local Government Act 1958*.

- (1) The maximum rate of interest to be paid—17.3 per cent.
- (2) The amount of principal money which is proposed to borrow is \$14 000.
- (3) The purpose for which the loan is to be applied is Council's cost of:
 - (a) 775 metres of half cost footpath construction at a cost of \$8200 Council contribution; and
 - (b) 131 metres of underground drainage at a cost of \$5800 Council contribution.
- (4) Term of loan—10 years.
- (5) Security—Mortgage Seal.
- (6) The money borrowed shall be repayable by providing out of the Municipal Fund 19 equal half-yearly instalments of principal and interest combined of \$1420.63.
- (7) The first instalment of interest and principal due on 1 February 1983.
- (8) Such money shall be repayable to the C.B.C. Savings Bank, Melbourne.

The plans and specifications and estimates of the proposed works and a statement showing the proposed expenditure of money to be borrowed are open for inspection at the Shire Office, Nelson Street, Nhill.

1486 V. J. SMITH, Shire Secretary

SHIRE OF MAFFRA

LOAN No. 77

Notice of Intention to Borrow the Sum of \$18 000 for Permanent Works and Undertakings

Notice is hereby given that the Council of the Shire of Maffra proposes to borrow the principal sum of \$18 000 secured by a charge over the general rates of the municipality, such sum to be raised by the grant of a mortgage in accordance with the provisions of the *Local Government Act 1958*.

1. The maximum rate of interest that may be paid is 17.3 per cent per annum.
2. The purpose for which the loan is to be applied is:

Installation of fire hydrants in association with water supply scheme at Coongulla, Glenmaggie, Glenmaggie Point and Maralinga areas	\$18 000
--------------------------------------------------------------------------------------------------------------------------------------	----------
3. The period of the loan shall be five years.
4. The moneys borrowed shall be repayable by providing out of the municipal fund ten half-yearly instalments of approximately \$2761.71 each including principal and interest on 1 May and 1 November during the currency of the loan. The first instalment shall be payable on 1 May 1983.
5. Such moneys shall be repayable to The Commissioners of The State Savings Bank of Victoria at the office of the said Commissioners, corner Elizabeth and Bourke Streets, Melbourne.

The plans and specifications and the estimate of the cost of the proposed works and a statement showing the proposed expenditure of the moneys to be borrowed are open for inspection at the office of the Council of the Shire of Maffra at Johnson Street, Maffra.

1451 J. RENNICK, Shire Secretary

Town and Country Planning Act 1961

SHIRE OF NARRACAN—SHIRE OF NARRACAN PLANNING SCHEME

INTERIM DEVELOPMENT ORDER 1981

NOTICE THAT A PLANNING SCHEME HAS BEEN PREPARED AND IS AVAILABLE FOR INSPECTION

Amendment No. 5

Notice is hereby given that the Shire of Narracan, in pursuance of its powers under the *Town and Country Planning Act 1961*, has prepared a Planning Scheme for Part Crown Allotment 164c, Parish of Moe, to re-zone the said land from Rural to Rural/Residential.

A copy of the scheme has been deposited at the office of the Shire of Narracan, Princes Highway, Trafalgar, and at the office of the Department of Planning, 235 Queen Street, Melbourne, and will be open for inspection during office hours by any person, free of charge.

Any persons affected by the Planning Scheme are required to set forth in writing objections they may have, addressed to the Shire Secretary, Shire of Narracan, Trafalgar, on or before 14 August 1982, and to state whether they wish to be heard in respect of their objections.

Dated 8 July 1982

1489

W. F. NELSON, Shire Secretary

Town and Country Planning Act 1961 (Twelfth Schedule)

SHIRE OF PAKENHAM PLANNING SCHEME, PART 1

NOTICE THAT A PLANNING SCHEME HAS BEEN PREPARED AND IS AVAILABLE FOR INSPECTION

Amendment No. 4, Princes Freeway

Notice is hereby given that the Council of the Shire of Pakenham in pursuance of its powers under the *Town and Country Planning Act 1961* has prepared a Planning Scheme for land being part of the Parishes of Pakenham, Nar Nar Goon and Bunyip, for the purpose of reserving land for "Proposed Main Road Purposes", being part of the land presently zoned Highway 1, Highway 2, Agricultural 1 and Industrial 2 Zones.

A copy of the scheme has been deposited at the Shire of Pakenham Municipal Offices, corner of John and Main Streets, Pakenham, and at the office of the Department of Planning, 235 Queen Street, Melbourne, and will be open for inspection during office hours by any person free of charge.

Any persons affected by the Planning Scheme are required to set forth in writing any submission they may wish to make with respect to the Scheme, addressed to the Shire Secretary, Shire of Pakenham, by 14 October 1982, and to state whether they wish to be heard in respect of their objections.

Dated 14 July 1982

1493

B. J. WALLIS, Shire Secretary

SHIRE OF SHERBROOKE

LOAN No. 169

Notice of Intention to Borrow the Sum of \$200 000 for Permanent Works and Undertakings

Notice is hereby given that the Council of the Shire of Sherbrooke proposes to borrow the principal sum of \$200 000 secured by a charge over the general rates of the municipality, such sum to be raised by the grant of a mortgage in accordance with the provisions of the *Local Government Act 1958*.

1. The maximum rate of interest that may be paid is 16.1 per centum per annum.
2. The purposes for which the loan is to be applied are:

	\$
Ferry Creek Avenue (part) reconstruction	10 000
Janiesleigh Road (part) reconstruction	20 000
Albert/Dawson/Townley Streets, intersection works	4 500
Upwey Recreation Reserve improvements—	
Drainage works	1 000
Landscaping and carparking	8 000

	\$
Emerald Lake Park Waterslide—purchase	35 000
Emerald Lake water quality improvement works—	
Filtration and chlorination system and wading pool construction	50 000
Plant—purchase of utility vehicle	6 500
Sherbrooke Aged Persons Hostel—construction (part cost)	50 000
Sub-division restructure fund	15 000
	200 000

3. The period of the loan shall be ten years.

4. The monies borrowed shall be repayable at maturity by the creation of a Sinking Fund by annual investment of \$14 137.19.

5. Such money shall be repayable to Insurance Commissioner, State Insurance Office, 480 Collins Street, Melbourne.

The plans and specifications and the estimate of the cost of the proposed works and a statement showing the proposed expenditure of the money to be borrowed are open for inspection at the Office of the Council of the Shire of Sherbrooke, Glenfern Road, Upwey.

1470 K. E. MATSON, General Manager

SHIRE OF SHERBROOKE

LOAN No. 170

Notice of Intention to Borrow the Sum of \$41 000 for Permanent Works and Undertakings

Notice is hereby given that the Council of the Shire of Sherbrooke proposes to borrow the principal sum of \$41 000 secured by a charge over the general rates of the municipality, such sum to be raised by the grant of a mortgage in accordance with the provisions of the Local Government Act 1958.

1. The maximum rate of interest that may be paid is 17.5 per centum per annum.

2. The purpose for which the loan is to be applied is:

	\$
Landscaping—Main Street, Monbulk	20 000
Coonara Community House—Multi-purpose Room	5 500
Emerald Lake Park—toilet block improvements	6 000
Fire Hydrants—Upwey Township Reserve	6 000
Impounded Vehicles Compound—Lysterfield Tip	3 500
	41 000

3. The period of the loan shall be ten years.

4. The monies borrowed shall be repayable by providing out of municipal funds half-yearly instalments of approximately \$4411.67, each including principal and interest on 1 March and 1 September during the currency of the loan. The first instalment shall be payable on 1 March 1983.

5. Such money shall be repayable to the Commissioners of the State Bank of Victoria at the Office of the said Commissioners, 385 Bourke Street, Melbourne.

The plans and specifications and the estimate of the cost of the proposed works and a statement showing the proposed expenditure of the monies to be borrowed are open for inspection at the Office of the Council of the Shire of Sherbrooke, Glenfern Road, Upwey.

1471 K. E. MATSON, General Manager

Town and Country Planning Act 1961

SHIRE OF SOUTH GIPPSLAND PLANNING SCHEME

NOTICE THAT A PLANNING SCHEME HAS BEEN PREPARED AND IS AVAILABLE FOR INSPECTION

Amendment No. 54, 1982

Notice is hereby given that the Shire of South Gippsland in pursuance of its powers under the Town and Country Planning Act 1961, has prepared a planning scheme for—

Part C.A's 8 and 9, Section A, Parish of Welshpool.

A copy of the scheme has been deposited at the Shire Office, 14–18 Pioneer Street, Foster 3960, and at the office of the Department of Planning, Victoria, 500 Collins Street, Melbourne, and will be open for inspection during office hours by any person free of charge.

Any persons affected by the scheme are required to set forth in writing any submissions they may wish to make with respect to the scheme, addressed to the Shire Secretary, P.O. Box 104, Foster, 3960, by 14 August 1982, and to state whether they wish to be heard in respect of their submissions.

1437 G. J. STEPHENS, Acting Shire Secretary

Town and Country Planning Act 1961

SHIRE OF TAMBO (LAKES ENTRANCE) PLANNING SCHEME

NOTICE THAT A PLANNING SCHEME HAS BEEN PREPARED AND IS AVAILABLE FOR INSPECTION

Amendment No. 40

Notice is hereby given that the Shire of Tambo in pursuance of its powers under the Town and Country Planning Act 1961, has prepared a Planning Scheme for the following:

That area situated on the northern side of Capes Road, Lakes Entrance, being Crown Allotment 11, Section A, Parish of Colquhoun, and Lot 9 on Lodged Plan No. 80076, rezone from Rural to Residential. A.

A copy of the Scheme has been deposited at the Shire Offices, Main Street, Bruthen, and at the Office of the Department of Planning, 235 Queen Street, Melbourne, and will be open for inspection during office hours by any person free of charge.

Any persons affected by the Planning Scheme are required to set forth in writing all objections they may have addressed to the Shire Secretary, Shire of Tambo, P.O. Box 10, Bruthen, 3885, on or before 14 August 1982, and state whether they wish to be heard in respect of their objections.

1435 W. J. HOBSON, Shire Secretary

Town and Country Planning Act 1961

SHIRE OF YACKANDANDAH—SHIRE OF YACKANDANDAH PLANNING SCHEME

RURAL AREA INTERIM DEVELOPMENT ORDER 1976

NOTICE THAT AN AMENDMENT TO AN INTERIM DEVELOPMENT ORDER HAS BEEN PREPARED AND IS AVAILABLE FOR INSPECTION

Amendment No. 9

Notice is hereby given that the Council of the Shire of Yackandandah in pursuance of its powers under the Town and Country Planning Act 1961 has prepared an amending Interim Development Order to give the Council greater control over the use, development and subdivision of highland areas in the Shire.

A copy of the amendment has been deposited at the Shire Office, High Street, Yackandandah; the Wodonga Office of the Department of Planning, Astra House, Jack Hore Place, Wodonga; and at the office of the Department of Planning (Plan Inspection Section), 5th Floor, 235 Queen Street, Melbourne, and will be open for inspection during office hours by any person free of charge.

Any persons affected by the amendment are required to set forth in writing any submissions they may wish to make with respect of the amendment addressed to the Shire Secretary, Shire of Yackandandah, High Street, Yackandandah, 3749 by 16 August 1982, and to state whether they wish to be heard in respect of their submissions.

Date 12 July 1982

1469 D. J. GRIFFITHS, Shire Secretary

Town and Country Planning Act 1961

GEELONG REGIONAL PLANNING SCHEME

NOTICE THAT A PLANNING SCHEME (AMENDING) HAS BEEN PREPARED AND IS AVAILABLE FOR INSPECTION

Amendment No. 48

Notice is hereby given that the Geelong Regional Commission in pursuance of its powers under the Town and Country Planning Act 1961, has prepared an Amendment

to the Geelong Regional Planning Scheme for part of the Geelong Region for the purpose of regulating, restricting or prohibiting the use and development of land within the following areas:

Item No. 1—Land fronting the northern side of Ryrie Street, Geelong, west of Union Street and east of Moorabool Street. Proposed zoning change from Public Purposes (Existing) 15 Gas and Fuel Corporation to District Business.

Item No. 2—Land situated on the north-west corner of Malop Street and Yarra Street, Geelong, extending in a northerly direction to Corio Street. Proposed zoning change from Public Purposes (Existing) 22 State Electricity Commission to District Business.

A copy of the Amendment has been deposited at this office—Geelong Regional Commission, State Government Offices, corner of Little Malop and Fenwick Streets, Geelong, at the office of the City of Geelong, Gheringhap Street, Geelong and at the office of the Department of Planning, 235 Queen Street, Melbourne; and will be open for inspection during office hours by any person, free of charge.

Any persons affected by the Amendment are required to set forth in writing any submissions they may wish to make with respect to the Amendment addressed to the Secretary, Mr. G. R. Cowling, Geelong Regional Commission, P.O. Box 770, Geelong, on or before 14 October 1982, and to state whether you wish to be heard in respect of that submission.

G. R. COWLING, Secretary, Geelong Regional Commission 1494

NEERIM SOUTH WATERWORKS TRUST

By-LAW No. 10

Water Restrictions

The Neerim South Waterworks Trust (hereinafter referred to as "the Trust"), in pursuance and exercise of the powers conferred by the *Water Act 1958* doth hereby make the By-law following, restricting the use for other than domestic purposes of water supplied by the Trust within the Neerim South Waterworks District.

1. This By-law shall have effect throughout the whole of the Neerim South Waterworks District, and shall come into operation as the Trust from time to time directs by notice published in a newspaper circulating generally within the said District and shall cease to have operation at such time as the Trust from time to time directs by a notice so published.

2. Subject to the provisions of Clause 3 of this By-law, no person shall, with water supplied by the Trust:

- (a) water any garden, lawn or other land (other than commercial market gardens, commercial nurseries, land used for growing of green feed for commercial poultry farms or public gardens) absolutely or between such hours each day as may be from time to time fixed by the Trust and published as herein provided, except by means of a hose held in the hand or by means of a can or other vessel held in the hand;
- (b) fill, add to or cleanse any private swimming pool;
- (c) wash any motor car or other vehicle except by means of a can or other vessel;

Provided that the Trust may by notice published as herein provided, invoke any or all of the restrictions set out in this clause.

3. No person shall, with water supplied by the Trust, water any land comprising sports grounds, golf courses, public and club bowling greens and public and club tennis courts, except by means of a hose held in the hand or by means of a can or other vessel, unless by written consent of the Trust first obtained.

4. Every person who uses or permits or suffers water supplied by the Trust to be used contrary to the provisions of this By-law shall be guilty of an offence and shall be liable to a penalty not exceeding One Hundred Dollars (\$100).

5. If any person with water supplied by the Trust wrongfully does or causes or permits to be done anything in contravention of this By-law, the Trust may (without

prejudice to any remedy in respect thereof) close or cut off any of the pipes by or through which water is supplied to him or for his use and may cease to supply him with water as provided by the *Water Act 1958*.

The foregoing By-law was made by the Neerim South Waterworks Trust on 16 December 1981, and the common seal of the said Trust was hereunto affixed, on 16 December 1981, in the presence of—

(SEAL) H. K. ARCHIBALD, Chairman
R. D. HONEYBONE, Commissioner
K. A. PRETTY, Secretary

Approved by the Governor in Council, 19 January 1982
—R. BIRD, Secretary, State Rivers and Water Supply Commission 1529

MOUNT BEAUTY SEWERAGE AUTHORITY

GENERAL NOTICE

The abovementioned Authority, having made provisions for carrying off the sewerage from each and every property which or any part of which is within the sewerage area hereinafter described, doth hereby declare that on and after 7 July 1982, each and every property described in the attached schedule shall be deemed to be a seweraged property within the meaning of the *Sewerage Districts Act 1958*.

Property Schedule—Lots 1 to 11, Stewarts Road; Lots 12 to 23, Braeside Court; Lots 10A, 10C, 10E, 10F, 10G, 10H, Stewarts Road; Lots 10D, 10J, Vails Road; Lots 429 to 476 and Lot 141, St. Bernard Drive; all in Tawonga South.

Further particulars regarding the areas in which sewers have been laid may be ascertained on enquiry at the Authority's office.

By order of the said Sewerage Authority

1468 A. J. McCULLOUGH, Chairman
J. B. O'BRIEN, Manager

TERANG SEWERAGE AUTHORITY

BY-LAW No. 10

Notice is hereby given that By-law No. 10—relating to Fees for House Drainage Plans—Alterations, Penalties for Non-Compliance with Authority's By-laws and Licence Fees—was passed by the Terang Sewerage Authority on 20 November 1981, confirmed on 18 December 1981, and approved by the Governor in Council on 19 January 1982.

A copy of the said By-law No. 10 may be inspected free of charge during office hours at the Authority's Office at 181 Manifold Street, Camperdown, or at its Terang Office.

1467 S. E. DEAN, Secretary

GEELONG WATERWORKS AND SEWERAGE TRUST

WATER BY-LAW No. 149

Notice is hereby given that the above by-law has been made and passed by the Trust and approved by the Governor in Council on 22 June 1982.

By-Laws Nos. 137, 142, 143, 145, 146 and 147 relating to Water are, accordingly, revoked as from that date.

The purpose of making the by-law is to consolidate previous amendments and incorporate current amendments, effective from 1 July 1982, designed to:

- (a) maintain relativity between charges for water supplied by measure for special purposes and the domestic charge for water supplied by measure which is to be increased to 23 cents per kilolitre from 1 July 1982;
- (b) maintain relativity between minimum annual charges for supplies of water to rural properties and the domestic annual charge;
- (c) increase the sum required as a deposit on meter testing to five dollars.

A copy of the by-law is open for inspection free of charge at the Trust's Offices, 61-67 Ryrie Street, Geelong during normal office hours—8.10 a.m. to 5.00 p.m. Monday to Friday.

By order

1450 L. C. SPITTY, Secretary

GEELONG WATERWORKS AND SEWERAGE TRUST

Pursuant to Section 60 of the *Geelong Waterworks and Sewerage Act 1958* (No. 6263) the Trust has prepared plans to indicate the particulars of sewers and underground works, the construction of which the Trust intends to begin, at a date not less than one month after publication of the notices, in or adjacent to the following locality within the Drainage Area.

Corner Argyle Street and Fife Court, Belmont; City of South Barwon.

Notice is hereby given that the plans indicated are open for public inspection at the Trust's Offices, 61-67 Ryrie Street, Geelong between the hours of 8.10 a.m. and 5.00 p.m. from Monday to Friday (public holidays excepted) by the owners or occupiers of land or premises within the Drainage Area.

1513

L. C. SPITTY, Secretary

TONGALA SEWERAGE AUTHORITY**GENERAL NOTICE***Section 134 Sewerage Districts Act*

The above-mentioned Sewerage Authority, having made provision for carrying off the sewage from each and every property which or any part of which is within the Sewerage Area hereinafter described doth hereby declare that on and after 15 June 1982 each and every property which or any part of which is within the said Sewerage Areas shall be deemed to be a seweraged property within the meaning of the *Sewerage Districts Act 1958*.

The Sewerage Areas herein before referred shall be known as Sewerage Areas Nos. 4 and 5.

The boundaries of the said Sewerage Areas Nos. 4 and 5 are delineated on plan No. DSP 2 which may be inspected at the office of the Tongala Sewerage Authority, or at the Office of the State Rivers and Water Supply Commission, 590 Orrong Road, Armadale.

1500

G. R. KELLETT, Chairman
B. PEARL, Secretary**TONGALA SEWERAGE AUTHORITY****By-Law No. 1**

Notice is hereby given that the By-Law passed by the Authority on 19 January 1982 and confirmed on 16 February 1982 has been approved by the Governor in Council on 22 June 1982.

The purport of this By-Law is as follows:

1. Incorporation of the Uniform Plumbing and Sewerage Regulations.
2. The Control of House Drainage Plans and Designs.
3. Licencing and Registration of Plumbers and Drainers.
4. Fixing of Fees for Services, Permits and Inspections.
5. Enabling the Authority to control the introduction of Trade Waste into the System.

A copy of the By-Law may be inspected, free of charge, at the office of the Authority, Shire Office, Tongala during Office Hours.

1501

B. PEARL, Secretary

NOTICE OF APPLICATION FOR A LICENCE TO DIVERT WATER FROM THE MURRAY RIVER AT PIAMBIE TO ALLOTMENT 53, NO SECTION, PARISH OF PIAMBIE

We hereby give notice of an application for a licence empowering us to divert water for a term of 15 years to the extent of 648 megalitres per annum at a maximum rate of 80 megalitres per day of 24 hours for the irrigation of 113 hectares and to occupy certain Crown Lands for diversion works.

Any objection to the granting of this application must be forwarded in writing to reach the State Rivers and Water Supply Commission, 590 Orrong Road, Armadale, 3143, before 6 August 1982 being thirty days from the publication of this notice.

JUNCTION HEIGHTS PTY. LTD.
FISHER & DOWELL PTY. LTD.

Care of P.O. Box 348, Swan Hill, Vic. 3585

1445

Take notice that Irma Yolanda Benitez on behalf of her infant daughter Gabriela Sharon Rafaella of Flat 10/28 Dunlop Avenue, Ascot Vale in the State of Victoria by Deed Poll dated 5 July 1982 changed her infant daughter's name to Gabriela Sharon Benitez. 1499

Notice is hereby given that the Lalbert Golf Club of Lalbert has applied for a lease pursuant to Section 134 of the *Land Act 1958* for a term of 21 years in respect of allotment 11 section A parish of Lalbert containing 30.48 hectares as a site for amusement and recreation and associated social activities connected therewith.

DWYER & BENNETT, barristers and solicitors, 194-208 Beveridge Street, Swan Hill, 3595 1539

Notice is hereby given that the Weeks Family Trust which operated from 6 Winifred Crescent, Glen Iris 3146 ceased trading as Tax and Business Consultants on 30 June 1982. It is proposed that the Trust be wound up as soon as possible. Trustees of the Trust is MAS Nominees Pty. Ltd. whose name will be changed to Independent Retirement Counsellors Pty. Ltd. and the new business will operate as a Company only. 1535

Notice is hereby given that the Partnership heretofore subsisting between Dianne Elaine Duggan, and Ian David Foord under the firm name of Foords Mower Service carrying on business at 246 Railway Parade, Noble Park in the State of Victoria has been dissolved as from 30 June 1982. That pursuant to a Deed of Agreement made on 23 June 1982 the said Dianne Elaine Duggan has retired as partner and as from 30 June 1982, the said Ian David Foord shall continue carrying on business under the firm name of Foords Mower Service at the same address.

STEVEN RALEIGH & ASSOCIATES, solicitors, 26 King Street, Melbourne, 3000 1480

Roy Rodrigues, Ray Jones, Ivan Rendell trading as Container Refrigeration Services.

Notice is hereby given that as of 1 July 1982 the above partnership has been dissolved and the business taken over by Container Refrigeration Services Pty. Ltd.

No further debts or obligations will be accepted by the partners. 1492

Notice is hereby given that the partnership heretofore subsisting between us the undersigned Christopher James Coombe and Lewis John Wilson carrying on business as a Retail Nursery, Pottery and Art Gallery at Anglesea under the style or firm of "C. J. Coombe and L. J. Wilson" has been dissolved by mutual consent as from 30 June 1982.

1507

C. J. COOMBE
L. J. WILSON

Notice is hereby given that the partnership subsisting between Victor James Ogilvie, Peter John Dempsey and Leslie Stuart Lowe carrying on business as Spray Painters, Leather Restoration, Motor Trimming, Detailing Service and Sand Blasting at Workshop 1, corner Rushdale and Ferntree Gully Roads, Knoxfield in the firm of Marque Restoration has been dissolved as from 26 May 1982.

VICTOR JAMES OGILVIE
PETER JOHN DEMPSEY
LESLIE STUART LOWE

Eggleston Clifton-Jones & Co., solicitors, of 20 Queen Street, Melbourne, 3000 1515

Take notice that Guy Barton of 223 Moor Street Fitzroy and William Alan Ridley and Wendy Anne Ridley of 71 Peel Street Windsor have dissolved their partnership which they carried on under the name of Cheeky Chaps on 9 June 1982 from which date the business continues to be carried on by the said Guy Barton alone.

MARTIN BARTFELD & ASSOCIATES, solicitors, 95A Riversdale Road, Hawthorn 1487

Notice is hereby given that the partnership between Dr Larry Light and Dr William McCoy was dissolved on 30 June 1982. The practice conducted by that partnership at 47 Bent Street, Altona is now being conducted solely by Dr William McCoy. 1495

Notice is hereby given that the Partnership heretofore subsisting between Paul Joseph Cariss and Christopher Ian Bishop carrying on business as Solicitors under the style and firm name of Cariss & Bishop at Professional Offices, Northland Shopping Centre, Murray Road, East Preston, is dissolved by mutual consent as from 30 June 1982.

PAUL JOSEPH CARISS, 15 Second Avenue, East Kew
C. I. BISHOP, 11 Arthur Street, Bundoora 1429

Take notice that the partnership between Jean Rene Blion of Unit 4, 7 Laburnum Street, Blackburn, in the State of Victoria and Gilles Noye of Unit 2, 68 Thomas Street, Brighton in the said State and carrying on the business of distributors, packagers and carriers of all types of sweets and consumables was dissolved on 30 June 1982.

Dated 1 July 1982

1434

JEAN RENE BLION
GILLES NOYE

Mr A. and Mrs A. Glass and Mr L. and Mrs E. W. Virt who previously carried on the business of Sandblasting and Spray painting in partnership under the name L. A. Sandblasting at Lot 2, Rohs Road, Bendigo have dissolved the partnership.

Mr A. and Mrs A. Glass will henceforth continue to trade in partnership with each other under the same name at the same address as from 1 July 1982.

MESSRS CAHILLS, solicitors of Cahill Chambers, View Point, Bendigo (054) 42 1333 1438

Crean, John & Murray wish to advise that Mr Gerald Crean retired as a partner of this firm on 30 June 1982, and from that date the accountancy practice will be conducted by Messrs Brian John and Richard Murray.

We are pleased to advise our clients that Mr Crean will remain with the firm in a consulting capacity and will be available for interviews at the same address 86A Murray Street, Colac. 1455

Notice is hereby given that the Partnership heretofore subsisting between the undersigned Kevin John Graske and Charles William Cann and Dorothy Ellen Cann carrying on business as Panel Beaters at 99 Moore Street Moe under the name of K. & C. Panels has been dissolved by mutual consent as from 6 July 1982. All debts due to and owing by the said later firm will be received and paid by Charles William Cann and Dorothy Ellen Cann who will continue to carry on the business at 99 Moore Street, Moe.

Dated at Moe, 6 July 1982

1456

KEVIN JOHN GRASKE
CHARLES WILLIAM CANN
DOROTHY ELLEN CANN

Notice is hereby given that the partnership heretofore subsisting between the undersigned Richard Alexander Heritage, Margaret Caroline Heritage, Gary Edwin Robert Heritage and Sandra Carol Heritage carrying on business as Bricklayers and Builders at 3 Menzies Street Charlton under the name of R. A. Heritage & Sons has been dissolved by mutual consent as from 30 June 1981. All debts due to and owing by the said late firm will be received and paid by Richard Alexander Heritage and Margaret Caroline Heritage who will continue to carry on the business at the same place.

Dated at Charlton, 18 June 1982

1479

R. A. HERITAGE
M. C. HERITAGE
G. E. R. HERITAGE
S. C. HERITAGE

Notice is given that the partnership of R. F. S. Crosbie and R. W. Pratt, practising under the name Crosbie, Doran & Co., Public Accountants, 266 Hampshire Road, Sunshine, terminated on 1 July 1982. As from that day a new partnership consisting of R. W. Pratt and B. N. Hoskin commenced practising under the name of Crosbie, Doran & Co. at the same location.

R. W. PRATT AND B. N. HOSKIN, for Crosbie, Doran & Co. 1527

Notice is hereby given that the partnership heretofore subsisting between us the undersigned Deidra Anderson of 4 Riversdale Road, Hawthorn and Edward Beacham of 22 Glyndebourne Avenue, Toorak carrying on business as Taxi Truck Proprietors, Property Owners and Investors at and from 1349 High Street, Malvern and 673 Heidelberg Road, Fairfield under the firm of Melba Taxi Truck and Car Company has been dissolved by mutual consent as from 30 June 1982.

Dated 30 June 1982

1534

DEIDRA ANDERSON
EDWARD BEACHAM

Notice is hereby given that the Partnership heretofore subsisting between Roger Ian Lohde and Lorraine Joy Lohde of Hillcrest Road, Maiden Gully, Kenneth William Pattison and Graham Robert Pattison of Fernhurst and Donald Robson McNaught and Elizabeth Jean McNaught formerly of Fernhurst but now of 4 Rutledge Street, Oakey, Queensland carrying on business as sub-dividers and land developers under the style or firm name of "Malap Investments" at Bendigo has been dissolved as from 30 June 1982 so far as concerns the said Roger Ian Lohde and Lorraine Joy Lohde who retire from the said firm. The said Partnership business shall continue to be carried on by Kenneth William Pattison and Graham Robert Pattison, Donald Robson McNaught and Elizabeth Jean McNaught under the firm name of "Malap Investments".

WATSON JAMES & ROGERS, solicitors, 61 Bull Street, Bendigo 1541

Notice is hereby given that the partnership heretofore subsisting between David Wills Cooke of 14 Norwood Street Sandringham and Euan Robert Clarke Evans of 25 Sandringham Road Sandringham carrying on business as Accountants at 130 Bank Street South Melbourne in the State of Victoria under the style or firm of Wills Cooke & Co. has been dissolved as from 30 June 1982.

Dated 30 June 1982

1549

DAVID WILLS COOKE
EUAN ROBERT CLARKE EVANS

P.M.A.F. PTY. LTD. (IN LIQUIDATION)

NOTICE OF FINAL MEETING

Notice is hereby given, in pursuance of section 272 of the Companies Act 1961, that a Final Meeting of Members of P.M.A.F. Pty. Ltd. (in Liquidation) will be held at the offices of J. N. Cooke, Foley & Co., 3rd Floor, A.M.P. Building, 17 Lydiard Street North, Ballarat on 16 August 1982 at 10.30 a.m., for the purpose of having an account laid before it showing the manner in which the winding up has been conducted and the property of the Company disposed of, and hearing any explanations that may be given by the Liquidator.

Dated 12 July 1982

DENNIS M. FOLEY, Liquidator

J. N. Cooke, Foley & Co., public accountants, 3rd Floor, A.M.P. Building, 17 Lydiard Street North, Ballarat, 3350 1533

Companies Act 1961, Section 272

NICOLAS ESQUIRE PTY. LTD. (IN LIQUIDATION)

NOTICE CONVENING FINAL MEETING OF MEMBERS AND CREDITORS

Notice is hereby given pursuant to section 272 of the Companies Act 1961 that a General Meeting of the members and creditors of the abovesaid company will be held at the offices of Ferrier Hodgson & Co., 24th Floor, 459 Collins Street, Melbourne, on Thursday, 12 August 1982 at 10.00 a.m. for the purpose of having an account laid before them showing the manner in which the winding up has been conducted and the property of the company disposed of and of hearing any explanations that may be given by the Liquidator.

Dated 9 July 1982

A. G. HODGSON, Liquidator

Ferrier Hodgson & Co., chartered accountants, 459 Collins Street, Melbourne, 3000 1542

Unclaimed Moneys Act 1962

Register of Unclaimed Moneys held by the—

Name of Owner on Books and Last Known Address	Total Amount Due to Owner	Description of Unclaimed Money	Date when Amount first became Payable
\$			
THE HERALD AND WEEKLY TIMES LIMITED			
Treasure, Brian S., 86 Harrison St, Nollamara, W. A.	22.00	Dividend	12.4.79
Treasure Island Pty. Ltd., 86 Harrison St, Nollamara, W. A.	16.50	" "	" "
Burns, William J., 29 David St, Hampton	12.50	Final Dividend	14.12.79
Cowlin, Lillian F., 51 Wooldridge St, Toowoomba, Qld.	20.63	" "	" "
Fisher, Lorraine M., 204 Barkers Rd, Hawthorn	13.75	" "	" "
Floyd, Wayne D., 962 Glenhuntly Rd, South Caulfield	12.50	" "	" "
Graves, Richard A., 10 Beleura Hill Rd, Mornington	23.50	" "	" "
Hough, Roland, 35 Boronia St, Kyle Bay, N.S.W.	19.88	" "	" "
Hunter, Adrian A., 7 Cousen Pl, Gladstone Park, Tullamarine	12.50	" "	" "
Jolley, Susan M., 511 Bourke St, Surry Hills, N.S.W.	12.50	" "	" "
McMahon, Maizie, 17 Bent St, Paddington, N.S.W.	237.50	" "	" "
Singleton, Owen P., 30/202 The Ave, Parkville	340.25	" "	" "
Taylor, Anthony J., 2/6 Ritchard Ave, Coogee, N.S.W.	12.50	" "	" "
Tiggeman, Shirley J., 24 Cordo Ave, Wattle Park, S.A.	41.25	" "	" "
O'Neill, Alexander R., Upper Bowen St, Roma, Qld.	13.75	" "	" "
Hannah, Anthony G., 6 Roy St, Mount Lawley, W.A.	12.50	" "	" "
Nefco Nominees Pty. Ltd., c/o James W. Paterson and Son, 1st Floor, 41-43 St, George's Tce, Perth, W.A.	27.50	" "	" "
Treasure, Brian S., 86 Harrison St, Nollamara, W.A.	55.00	" "	" "
Treasure Island Pty. Ltd., 86 Harrison St, Nollamara, W.A.	41.25	" "	" "
1447			
EAST AFRICAN COFFEE PLANTATIONS LIMITED			
Donnelly, Norman, c/o Nichols Point, P.O. Nichols Point	98.00	Dividend	15.12.80
Hally, Mal, G.P.O. Box 87, Sydney, N.S.W.	14.00	" "	" "
Joss, Sarah (Estate of) c/o D. Sinclair, Belmont House, 26 Belmont Rd, Mosman, N.S.W.	18.90	" "	" "
Kortum, Kevin, Grosvenor Hotel, 353 Little Collins St, Melbourne	14.00	" "	" "
Mann, Beverley H., 40 Holyrood St, Hampton	14.00	" "	" "
McDonald, Michael, c/o Wester Mining Corp. Ltd., 360 Collins St, Melbourne	42.00	" "	" "
McKenzie, Brian, 1 Ashley St, Reservoir	28.00	" "	" "
Oliver, Olga 99b Carrington Rd, Box Hill	17.50	" "	" "
Rice, James W., 117 Doveton St, South Ballarat	70.00	" "	" "
Ross-Walker, David, c/o National Bank, Narrogin, W.A.	14.00	" "	" "
Stevens, Michael G., 7 Barry Rd, Burwood	28.00	" "	" "
1448			

In the matter of the Companies Act 1961; and in the matter of W. K. WILLIAMS PTY. LTD.

Notice is hereby given that an Extraordinary General Meeting of the abovenamed company duly convened and held at 500 Collins Street, Melbourne on 8 July 1982 the following special resolution was duly passed—

"That the company be wound-up voluntarily and that John Stuart Walker, Chartered Accountant of 500 Collins Street, Melbourne be appointed Liquidator for the purpose of such winding-up."

Dated 8 July 1982

1550

K. KOM, Chairman

The Companies Act 1961
COMMERCIAL GLASS & GLAZING PTY. LTD. (IN VOLUNTARY LIQUIDATION)

NOTICE Re WINDING UP

Notice is hereby given that at meetings of members and creditors held on 7 July 1982, it was resolved that the Company be wound up voluntarily and that Ian Dunbar King Chartered Accountant of 343 Little Collins Street, Melbourne, be appointed liquidator of the Company.

Notice is also given that creditors proofs of debt should be lodged with the liquidator within 21 days of the date hereof in order to participate in any distribution.

Dated 13 July 1982

IAN DUNBAR KING, Liquidator

Benjamin, King & Boyd, 343 Little Collins Street, Melbourne, 3000 1551

The Companies Act 1961
ALCRAFT COMMERCIAL WINDOWS PTY. LTD. (IN VOLUNTARY LIQUIDATION)
NOTICE Re WINDING UP

Notice is hereby given that at meetings of members and creditors held on 7 July 1982, it was resolved that the Company be wound up voluntarily and that Ian Dunbar King Chartered Accountant of 343 Little Collins Street, Melbourne, be appointed liquidator of the Company.

Notice is also given that creditors proofs of debt should be lodged with the liquidator within 21 days of the date hereof in order to participate in any distribution.

Dated 13 July 1982

IAN DUNBAR KING, Liquidator
Benjamin, King & Boyd, 343 Little Collins Street, Melbourne, 3000 1552

Companies Act 1961, Section 254 (2) (b)
PINDESS INVESTMENTS PTY. LTD. (IN VOLUNTARY LIQUIDATION)

Notice is hereby given that at an Extraordinary General Meeting of members of the abovenamed company held on 28 June 1982 it was resolved that the company be wound up voluntarily and that Raymond Walter Betts of Messrs. Coopers & Lybrand, 461 Bourke Street, Melbourne, be appointed Liquidator.

Dated 29 June 1982

R. W. BETTS, Liquidator
Coopers & Lybrand, 461 Bourke Street, Melbourne, Vic. 3000 1553

In the matter of the Companies (Victoria) Code; and in the matter of BAJAJ AUSTRALIA PTY. LIMITED

Notice is hereby given that at an Extraordinary General Meeting of the abovenamed company duly convened and held at the office of B. O. Smith & Son, 500 Collins Street, Melbourne, in the State of Victoria, on 9 July 1982 the following special resolution was duly passed:

"That it has been proved to the satisfaction of this meeting of Members of Bajaj Australia Pty. Limited that the company cannot, by reason of its liabilities, continue in business and it is advisable to wind-up same and accordingly that the company be wound-up voluntarily" and that James Scott Romanis of B. O. Smith & Son be appointed Liquidator.

Dated 9 July 1982

J. QUEALY, Director

B. O. Smith & Son, 500 Collins Street, Melbourne, 3000
1526

Notice is hereby given of a meeting of Thomas Claudius Seabrook Investments Pty. Ltd. (in Liquidation) to be held at the office of Stannard, Coghlan & Jackson, 457 St. Kilda Road, Melbourne on Thursday, 19 August 1982, at 10.00 a.m. to consider an account of how the winding up has been conducted.

JOHN BONGIORNO PTY. LTD. (IN LIQUIDATION)
NOTICE OF FINAL MEETING

Notice is hereby given, in pursuance of section 272 of the Companies Act 1961, that a Final Meeting of Members of John Bongiorno Pty. Ltd. (in Liquidation) will be held at the offices of J. N. Cooke, Foley & Co., 3rd Floor, A.M.P. Building, 17 Lydiard Street North, Ballarat on 16 August 1982 at 10.00 a.m., for the purpose of having an account laid before it showing the manner in which the winding up has been conducted and the property of the Company disposed of, and hearing any explanations that may be given by the Liquidator.

Dated 12 July 1982

DENNIS M. FOLEY, Liquidator

J. N. Cooke, Foley & Co., public accountants, 3rd Floor, A.M.P. Building, 17 Lydiard Street North, Ballarat, 3350
1532

Companies Act 1961, Section 254 (2) (b)

WARTARAH PTY. LTD. (IN VOLUNTARY LIQUIDATION)

Notice is hereby given that at an Extraordinary General Meeting of members of the abovenamed company held on 1 July 1982 it was resolved that the company be wound up voluntarily and that Michael John Walter of Messrs. Coopers & Lybrand, 461 Bourke Street, Melbourne, be appointed Liquidator.

M. J. WALTER, Liquidator

Coopers & Lybrand, 461 Bourke Street, Melbourne, Vic. 3000
1554

APSCAP PTY. LTD. (IN VOLUNTARY LIQUIDATION)

At an Extraordinary General Meeting of the abovenamed Company, duly convened and held at 1/14 Grange Road, Toorak on 1 July 1982 the following resolutions were duly passed:

That the Company be wound up voluntarily. That Alan John Fookes of 257 Collins Street, Melbourne, Victoria, be appointed liquidator.

Dated 5 July 1982

1555

ALAN J. FOOKES, Liquidator

K. J. TURTON PTY. LTD. (IN VOLUNTARY LIQUIDATION)

NOTICE CONVENING FINAL MEETING, PURSUANT TO SECTION 272 OF THE COMPANIES ACT 1961

Pursuant to Section 272 of the Companies Act 1961 a general meeting of members of the abovenamed company will be held at 57 Jells Road, Wheelers Hill on Thursday, 12 August 1982 at 10.00 a.m. for the purpose of having an account laid before them showing the manner in which the winding up has been conducted and the property disposed of and of hearing any explanation that may be given by the Liquidator.

Dated 8 July 1982

1506

JULIAN F. COLES, Liquidator

Companies Act 1961

C. & M. TSINDOS PTY. LTD. (IN VOLUNTARY LIQUIDATION)

Notice is hereby given that at an Extraordinary General Meeting of the members of the abovenamed Company held on 29 June 1982 it was resolved that the Company be wound up voluntarily and that David John Grisbrook be appointed Liquidator.

Dated 29 June 1982

D. J. GRISBROOK, Liquidator

Grisbrook, Snow & Associates, chartered accountants, 241 Park Street, South Melbourne, 3205
1430

The Companies Act 1961, Section 254 (2) and Regulation 54

BOULEVARD MOTORS PTY. LTD. (IN LIQUIDATION)

Notice is hereby given that at an Extraordinary General Meeting of the Members of the abovenamed Company held on 30 June 1982, it was resolved that the Company be wound up voluntarily, and at a meeting of creditors held on the same day pursuant to section 260, it was resolved that for such purpose, Stephen Graham Marks, of 60 Albert Road, South Melbourne, chartered accountant, be appointed Liquidator.

Dated 30 June 1982

S. G. MARKS, Liquidator

Stephen G. Marks & Co., chartered accountants, 4th Floor, 60 Albert Road, South Melbourne, 3205. Telephone: 699 3766
1431

Companies Act 1961

FALAK OF BENDIGO PTY. LIMITED

Notice is hereby given pursuant to section 254 (2) of the Companies Act 1961, that at an Extraordinary General Meeting of Shareholders of Falak of Bendigo Pty. Limited held on 25 June 1982 the following Resolution was passed as a Special Resolution:

1. That Falak of Bendigo Pty. Limited complete the necessary legal requirements under the Companies Act to wind up the operation of the Company.

2. That David Tasman Andrew of 101 Queen Street, Bendigo be appointed Liquidator of the Company.

Dated 25 June 1982

1439

GODFREY ESTATES PTY. LTD. (IN VOLUNTARY LIQUIDATION)

NOTICE CONVENING FINAL MEETING

Notice is hereby given that a Final Meeting in the Voluntary Liquidation of the abovenamed Company will be held at the offices of A. H. G. Clarke & Co., First Floor, 460 Bourke Street, Melbourne, on Friday, 20 August 1982 at 2.00 p.m. to consider the Liquidators' final accounts of the voluntary winding up.

A. M. LOCKE, Liquidator

1446

J. J. TEMPLETON, Liquidator

In the matter of the Companies (Victoria) Code; and in the matter of L.H.N. NOMINEES PTY. LTD. (in Voluntary Liquidation)—Notice of Final Meeting of Members, Pursuant to Section 411

Notice is hereby given in pursuance of section 411 of the Companies (Victoria) Code that a General Meeting of the members of the Company will be held at the office of W. Marshall & Associates, Chartered Accountants, of Suite 2, 162 Albert Road, South Melbourne on 16 August 1982 at 10 o'clock in the forenoon for the purpose of having an account laid before it showing the manner in which the winding up has been conducted and the property of the Company disposed of, and hearing any explanation that may be given by the Liquidators.

Dated 7 July 1982

1454

N. K. CUTHBERT, Liquidator

Companies Act 1961

J.M.L. PLASTER CO. PTY. LTD. (IN LIQUIDATION)

Notice is hereby given that a Fourth dividend is intended to be declared in the above matter. Creditors who have not proved their debts by 5 August 1982, will be excluded therefrom.

Dated 6 July 1982

RONALD DENNIS WIDDOWS, 703 South Road,
Moorabbin, Vic. 3189 1457

Companies Act 1961

J.M.L. PLASTER (FIXING) CO. PTY. LTD. (IN LIQUIDATION)

Notice is hereby given that a Fourth dividend is intended to be declared in the above matter. Creditors who have not proved their debts by 5 August 1982, will be excluded therefrom.

Dated 6 July 1982

R. D. WIDDOWS, 703 South Road, Moorabbin, Vic.
3189 1458

In the Supreme Court of Victoria—1982 Co. No. 12579—
In the matter of the Companies Act 1961; and in the
matter of GOLDCEL NOMINEES PTY. LTD.

Notice is hereby given that a petition for the winding up of the abovenamed Company by the Supreme Court was, on 22 June 1982, presented by Harlaw Nominees Pty. Ltd. and that the said petition is directed to be heard before the Court sitting at the Fifteenth Court, Law Courts, Lonsdale Street, Melbourne, at the hour of 10.30 a.m. on 29 July 1982; and any creditor or contributory of the said company desiring to support or oppose the making of an order on the said petition may appear at the time of hearing by himself or his counsel for that purpose; and a copy of the petition will be furnished to any creditor or contributory of the said company requiring the same by the undersigned on payment of the regulated charge for the same.

The Petitioner's address is 112 James Street, Templestowe.

The Petitioner's solicitor is Mr D. J. M. Harle of Harle & Murphy, of 145 Parker Street, Templestowe.

D. J. M. HARLE

NOTE—Any person who intends to appear on the hearing of the said petition must serve on or send by post to the abovenamed D. J. M. Harle notice in writing of his intention so to do. The notice must state the name and address of the person or, if a firm, the name and address of the firm, and must be signed by the person or firm or his or their solicitor (if any), and must be served or, if posted, must be sent by post in sufficient time to reach the abovenamed not later than four o'clock in the afternoon of 28 July 1982 (the day before the day appointed for the hearing of the Petition or the Friday preceding the day appointed for the hearing of the Petition if such day is a Monday or a Tuesday following a public holiday).

1473

Companies Act 1961—In the matter of WHITEMONT
TRANSPORT PTY. LTD. (in Liquidation)

Notice is hereby given that at an extraordinary meeting of the Members of the abovenamed Company held on 8 July 1982, it was resolved that the company be wound up voluntarily and at a Meeting of Creditors held on the same day pursuant to section 260 it was resolved that for such purpose Mr E. T. Bent of 144 Jolimont Road, East Melbourne, Public Accountant, be appointed Liquidator.

Notice is also given that the Liquidator has fixed 9 August 1982, as the day on or before which creditors of the Company are to prove their debts or claims and to establish any title they may have to priority under section 292 of the Companies Act.

Dated 8 July 1982

E. T. BENT, Liquidator

Bent & Cogle, public accountants, 144 Jolimont Road,
East Melbourne, 3002 1474

The Companies Act 1961

HIGHTT LAUNDRETTE COMPANY PTY. LTD.

NOTICE OF MEETING OF MEMBERS, PURSUANT TO SECTION 272

Notice is hereby given that pursuant to section 272 of the Companies Act 1961, the final meeting of members of Hightt Laundrette Company Pty. Ltd. will be held at the offices of Sabri Lipins Cooper, 765 Glenferrie Road, Hawthorn on 16 August 1982 at 9.45 a.m. for the purposes of laying before the meeting the liquidator's final account and report and giving any explanation thereof.

Dated 7 July 1982

JAMES L. SABRI, Liquidator

Sabri Lipins Cooper, chartered accountants, 765 Glenferrie Road, Hawthorn, 3122 1475

The Companies Act 1961

BANONIL PTY. LTD.

NOTICE OF MEETING OF MEMBERS, PURSUANT TO SECTION 272

Notice is hereby given that pursuant to section 272 of the Companies Act 1961, the final meeting of members of Banonil Pty. Ltd. will be held at the offices of Sabri Lipins Cooper, 765 Glenferrie Road, Hawthorn on 16 August 1982 at 10.15 a.m. for the purposes of laying before the meeting the liquidator's final account and report and giving any explanation thereof.

Dated 7 July 1982

JAMES L. SABRI, Liquidator

Sabri Lipins Cooper, chartered accountants, 765 Glenferrie Road, Hawthorn, 3122 1476

The Companies Act 1961

GERALDA TRADING COMPANY PTY. LTD. (IN VOLUNTARY LIQUIDATION)

NOTICE OF FINAL MEETING

Notice is hereby given that, pursuant to section 272 of the Companies Act 1961, a final meeting of the members of the abovenamed Company will be held at the office of the Liquidator, 2 Drummond Street South, Ballarat on 6 September 1982 at 10 a.m. for the purpose of presenting the Liquidator's account of the winding up.

Dated 7 July 1982

1477

N. WESTBROOK, Liquidator

Companies Act 1981

COWARD SALES PROPRIETARY LIMITED (IN VOLUNTARY LIQUIDATION)

NOTICE OF FINAL MEETING

Notice is hereby given that a meeting of the members of Coward Sales Proprietary Limited (in voluntary liquidation) will be held at 146 Langtree Avenue, Mildura, in the State of Victoria, on 12 August 1982 at 10 o'clock in the forenoon for the purpose of laying before the meeting an account showing how the winding up has been conducted and the property of the company disposed of, and giving any explanation thereof.

Dated 7 July 1982

1478

J. MCKENDRICK, Liquidator

The Companies Act 1961

VINDIN PROPRIETARY LIMITED (IN LIQUIDATION)

NOTICE CONVENING FINAL MEETING OF THE COMPANY, PURSUANT TO SECTION 272

Notice is hereby given pursuant to section 272 of the Companies Act 1961, that a meeting of the abovenamed Company will be held in the offices of Wallace, McMullin & Smail, 499 St. Kilda Road, Melbourne, 3004, on Monday, 16 August 1982 at 10.00 a.m. for the purpose of having an account laid before them showing the manner in which the winding up has been conducted and the property of the Company disposed of and of hearing any explanations that may be given by the Liquidator.

Dated 14 July 1982

1543

W. L. VINDIN, Liquidator

Companies (Victoria) Code 1982
PACEMAKER HOMES (NORTHERN) PTY. LTD.

NOTICE OF MEETING OF CREDITORS

Notice is hereby given that pursuant to section 398 of the Companies (Victoria) Code 1982 a meeting of the creditors of Pacemaker Homes (Northern) Pty. Ltd. will be held at the C.W.A. Hall, Kiewa Street, Albury on 20 July 1982, at 10.00 a.m., the company having held a meeting of its members for the purpose of considering and passing the special resolution that the company be wound up voluntarily.

Dated 14 July 1982

J. O'BRIEN, Secretary

Duesburys, chartered accountants, 114 William Street,
Melbourne, 3000 1544

Companies (Victoria) Code 1982
PACEMAKER HOMES (VIC.) PTY. LTD.

NOTICE OF MEETING OF CREDITORS

Notice is hereby given that pursuant to section 398 of the Companies (Victoria) Code 1982 a meeting of the creditors of Pacemaker Homes (Vic.) Pty. Ltd. will be held at the Mid-City Motel Pty. Ltd., 525 Raglan Parade, Warrnambool on 22 July 1982, at 10.30 a.m., the Company having held a meeting of its members for the purpose of considering and passing the special resolution that the company be wound up voluntarily.

Dated 14 July 1982

J. O'BRIEN, Secretary

Duesburys, chartered accountants, 114 William Street,
Melbourne, 3000 1545

The Companies Act 1961
K.R.D.C. PTY. LTD. (IN VOLUNTARY LIQUIDATION)
NOTICE OF CONVENING FINAL MEETING OF MEMBERS,
PURSUANT TO SECTION 272

Notice is hereby given, in pursuance of section 272 of the Companies Act 1961, that a General Meeting of the members of the abovementioned Company will be held on 18 August 1982 at 12.00 noon at the office of Smith, Peacock & Henshaw, 5th Floor, 124 Exhibition Street, Melbourne for the purpose of having an account laid before them showing the manner in which the winding up has been conducted and the property of the Company disposed of, and hearing any explanation that may be given by the Liquidator.

Dated 9 July 1982

D. A. N. McLARDY, Liquidator

Smith, Peacock & Henshaw, chartered accountants, 5th
Floor, 124 Exhibition Street, Melbourne 1546

Form 92

Companies Act 1961, Section 272
Companies Regulations, Regulations 26 (2) (b)
ACE BUTCHERS PTY. LIMITED
REGAL SMALLGOODS PTY. LIMITED
NOTICE OF FINAL MEETING IN VOLUNTARY WINDING UP

Take notice that the affairs of the abovenamed companies are now fully wound-up and that in pursuance of section 272 (1) of the Companies Act 1961, general meetings of the companies will be held at the Offices of J. W. McEncroe, Chartered Accountant, 4th Floor, 500 Collins Street, Melbourne on 17 August 1982 at 11 and 11.30 o'clock in the forenoon for the purpose of laying before them an account showing how the windings-up have been conducted and the property of the companies disposed of and giving any explanation thereof.

Dated 9 July 1982

1547

J. W. McENCROE, Liquidator

Companies Act 1961, Section 272 (2)—In the matter of
GALLAGHER HOLDINGS PTY. LTD.—Notice of Final
Meeting

Notice is hereby given that pursuant to section 272 of the Companies Act, the final meeting of the members of the abovenamed company will be held at the offices of Price Waterhouse, 11th Floor, 447 Collins Street, Melbourne at 10.00 a.m. on 11 August 1982 for the purpose of having an account laid before it showing the manner in which the winding up has been conducted and the property of the company disposed of, and hearing any explanation that may be given by the liquidator.

Dated 14 July 1982

J. M. PERRINS, Liquidator

Price Waterhouse, chartered accountants, 447 Collins
Street, Melbourne, 3000 1548

Co-operative Housing Societies Act 1958; and Companies
Act 1961—EQUITY CO-OPERATIVE HOUSING SOCIETY LIMITED
(in Liquidation)—Special Resolution

At a Special General Meeting of the above-named Society duly convened and held at 434 Nepean Highway, Frankston on 1 July 1982 at 6 p.m. the subjoined Special Resolution was duly passed:

"That the Society having successfully completed its objectives 26 months ahead of its expected term be wound up voluntarily and that Dawn Yvonne Lowe of 434 Nepean Highway, Frankston be appointed liquidator for the purposes of the winding up."

J. A. WHYTE, Chairman of the Meeting
D. Y. LOWE, Secretary

Notice is hereby given that all persons having any claim against the above-named Society are required on or before 4 August 1982 to send their names and addresses and particulars of their debts or claims to the above-mentioned liquidator, and if so required by notice in writing from the said liquidator are personally, or by their solicitors, to place as shall be specified in such notice; or, in default thereof, they shall be excluded from the benefit of any distribution made before such debts or claims are so lodged or proved.

Dated 11 July 1982

D. Y. LOWE, liquidator, 434 Nepean Highway, Frankston
1490

In the Supreme Court of Victoria—1982 No. Co. 12591—
In the matter of the Companies Act 1961; and in the
matter of TECNICAST PTY. LTD.

Notice is hereby given that a petition for the winding up of the abovenamed Company by the Supreme Court was, on 28 June 1982, presented by Barbara Dawborn, John Dawborn, Stella Marion O'Brien, Rodney Investments Pty. Ltd. and Lorrandi Pty. Ltd. and that the said Petition is directed to be heard before the Court sitting at the Practice Court, Law Courts Melbourne on 29 July 1982 and any creditor or contributory of the said company desiring to support or oppose the making of an order on the said Petition may appear at the time of hearing by himself or his Counsel for that purpose and a copy of the Petition will be furnished to any creditor or contributory of the said company requiring the same by the undersigned on payment of the regulated charge for the same.

The first and second Petitioners' addresses are respectively 27 The Rampart Castlecrag, New South Wales, the third Petitioner's address is 60 Rembrandt Drive, Middle Cove, New South Wales, the fourth Petitioner's address is 138 Pennant Hills Road, Parramatta, New South Wales, and the fifth Petitioner's address is 1 Little Collins Street, Melbourne, Victoria.

The Petitioner's solicitor is Mr M. J. Redfern of M. J. Redfern of 521 Burke Road, Camberwell.

M. J. REDFERN, Solicitor for the Petitioners

NOTE—Any person who intends to appear on the hearing of the said Petition must serve or send by post to the abovenamed Solicitor notice in writing of his intention so to do. The notice must state the name and address of the person or, if a firm, the name and address of the firm, and must be signed by the person or firm, or his or their solicitor (if any) and must be served or, if posted, must be sent by post in sufficient time to reach the abovenamed not later than four o'clock in the afternoon of 28 July 1982.

1496

Form 92

The Companies Act 1961, Section 272 (1)

Companies Regulation

DREXEL CONTRACT FURNISHINGS PTY. LTD. (IN LIQUIDATION)

NOTICE OF MEETING OF CREDITORS AND CONTRIBUTORIES
 Notice is hereby given that a final meeting of the creditors and contributories of Drexel Contract Furnishings Pty. Ltd. (in Liquidation) will be held at the office of Orr, Martin & Waters, Top Floor, 460 Bourke Street, Melbourne, on Thursday, 12 August 1982 at 11.30 a.m. to receive the liquidator's account of his acts and dealings and of the conduct of the winding up and hearing any explanations thereof.

Dated 8 July 1982

ROBERT A. WATERS, Liquidator

Orr, Martin & Waters, chartered accountants, 460 Bourke Street, Melbourne, 3000. Telephone 602 1644 1498

KOROIT WEIGHBRIDGE COMPANY PROPRIETARY LIMITED (IN VOLUNTARY LIQUIDATION)

SPECIAL RESOLUTION TO WIND UP

At an extraordinary general meeting of the abovenamed Company duly convened and held at 67-69 Kepler Street, Warrnambool, Victoria, on 12 July 1982, the following Resolution was passed as a Special Resolution:

"That the Company be wound up voluntarily."

At the abovementioned meeting John Forbes Hunt was appointed Liquidator for the purpose of the winding up.

"Notice is also given that after 21 days from this date, I shall proceed to distribute the assets. All creditors having any claim against the Company should furnish particulars of same by that date, otherwise I shall proceed to distribute the assets without regard to their claim."

Dated 14 July 1982

1504

JOHN F. HUNT, Liquidator

The Companies Act 1961

VINEYARD RESTAURANT INVESTMENTS PTY. LTD.

NOTICE OF MEETING OF MEMBERS, PURSUANT TO SECTION 272

Notice is hereby given that pursuant to section 272 of the Companies Act 1961, the final meeting of members of Vineyard Restaurant Investments Pty. Ltd. will be held at the offices of Sabri Lipins Cooper, 765 Glenferrie Road, Hawthorn on 16 August 1982 at 9.15 a.m. for the purposes of laying before the meeting the liquidator's final account and report and giving any explanation thereof.

Dated 7 July 1982

ERIK LIPINS, Liquidator

Sabri Lipins Cooper, chartered accountants, 765 Glenferrie Road, Hawthorn, 3122 1505

In the Supreme Court of Victoria—In the matter of the Companies (Victoria) Code; and in the matter of MERIDYN PTY. LTD.

Notice is hereby given that a petition for the winding up of the abovenamed Company by the Supreme Court was on 8 July 1982 presented by Eric John Unger, Deputy Commissioner of Taxation of the Commonwealth of Australia and that the said petition is directed to be heard before the Court sitting at the Fifteenth Court, Law Courts, Lonsdale Street, Melbourne, at the hour of 10.30 o'clock in the forenoon on 12 August 1982 and any creditor or contributory of the said company desiring to support or oppose the making of an order on the said petition may appear at the time of hearing by himself or his Counsel for the purpose; and a copy of the said petition will be furnished to any creditor or contributory of the said company requiring the same by the undersigned on payment of the regulated charge for the same.

The Petitioner's official address is 350 Collins Street, Melbourne.

The Petitioner's Solicitor is B. J. O'Donovan, Crown Solicitor for the Commonwealth, of 99 Queen Street, Melbourne.

B. J. O'DONOVAN

NOTE—Any person who intends to appear on the hearing of the said petition must serve on or send by post to the abovenamed B. J. O'Donovan notice in writing of his intention so to do. The notice must state the name and address of the person, or, if a firm, the name and address of the firm, and must be signed by the person or firm, or his, or their solicitor (if any), and must be served, or, if posted, must be sent by post in sufficient time to reach the abovenamed not later than 4.00 in the afternoon of 11 August 1982. 1519

In the Supreme Court of Victoria—In the matter of the Companies (Victoria) Code; and in the matter of G. J. & D. E. FINN PTY. LTD.

Notice is hereby given that a petition for the winding up of the abovenamed Company by the Supreme Court was on 8 July 1982 presented by Eric John Unger, Deputy Commissioner of Taxation of the Commonwealth of Australia and that the said petition is directed to be heard before the Court sitting at the Fifteenth Court, Law Courts, Lonsdale Street, Melbourne, at the hour of 10.30 o'clock in the forenoon on 12 August 1982 and any creditor or contributory of the said company desiring to support or oppose the making of an order on the said petition may appear at the time of hearing by himself or his Counsel for the purpose; and a copy of the said petition will be furnished to any creditor or contributory of the said company requiring the same by the undersigned on payment of the regulated charge for the same.

The Petitioner's official address is 350 Collins Street, Melbourne.

The Petitioner's Solicitor is B. J. O'Donovan, Crown Solicitor for the Commonwealth, of 99 Queen Street, Melbourne.

B. J. O'DONOVAN

NOTE—Any person who intends to appear on the hearing of the said petition must serve on or send by post to the abovenamed B. J. O'Donovan notice in writing of his intention so to do. The notice must state the name and address of the person, or, if a firm, the name and address of the firm, and must be signed by the person or firm, or his, or their solicitor (if any), and must be served, or, if posted, must be sent by post in sufficient time to reach the abovenamed not later than 4.00 in the afternoon of 11 August 1982. 1520

In the Supreme Court of Victoria—No. Co. 12626—In the matter of the Companies Act 1961; and in the matter of CORNERSTONE HOLDINGS PTY. LIMITED

Notice is hereby given that a petition for the winding up of the abovenamed company by the Supreme Court, was, on 2 July 1982 presented by Jennings Industries Limited who carries on business at 650 Springvale Road, Mulgrave, in the State of Victoria and that the said petition is directed to be heard before the Court sitting at Melbourne at the hour of 10.30 o'clock in the forenoon on 5 August 1982; and any creditor or contributory of the said company desiring to support or oppose the making of an order on the said petition may appear at the time of hearing by himself or his Counsel for that purpose; and a copy of the petition will be furnished to any creditor or contributory of the said company requiring the same by the undersigned on payment of the regulated charge for the same.

The Petitioner's address is 690 Springvale Road, Mulgrave, in the State of Victoria.

The Petitioner's Solicitors are Messrs Russell, Kennedy & Cook, of 257 Collins Street, Melbourne.

RUSSELL, KENNEDY & COOK

NOTE—Any person who intends to appear on the hearing of the said petition must serve on or send by post to the abovenamed Solicitors, Messrs Russell, Kennedy & Cook at 257 Collins Street, Melbourne, notice in writing of his intention so to do. The notice must state the name and address of the person, or, if a firm, the name and address of the firm, and must be signed by the person or firm, or his, or their Solicitor (if any) and must be served, or, if posted, must be sent by post in sufficient time to reach the abovenamed not later than 4 o'clock in the afternoon of 4 August 1982. 1521

In the Supreme Court of Victoria—1982 Co. 12629—In the matter of the Companies (Victoria) Code; and in the matter of MOAMA TRADERS-PRODUCE MERCHANTS PTY. LTD.; and in the matter of a Petition dated 7 July 1982

Notice is hereby given that a Petition for the winding up of the abovenamed Company by the Supreme Court was on 7 July 1982 presented by Bunge (Australia) Pty. Ltd. And that the said Petition is directed to be heard before the Court sitting at Melbourne at the hour of 10.30 o'clock in the forenoon on 12 August 1982.

And any creditor or contributory of the said Company desiring to support or oppose the making of an Order on the said Petition may appear at the time of hearing by himself or his counsel for that purpose.

And a copy of the Petition will be furnished to any creditor or contributory of the said Company requiring the same by the undersigned on payment of the regulated charge for the same.

The Petitioner's address is 140 William Street, Melbourne.

The Petitioner's Solicitors are Messrs Middletons, Oswald Burt & Co., of 140 William Street, Melbourne.

MIDDLETONS, OSWALD BURT & CO., solicitors for the petitioner

NOTE—Any person who intends to appear on the hearing of the said petition must serve on or send by post to the abovenamed Messrs Middletons, Oswald Burt & Co. of 140 William Street, Melbourne, notice in writing of his intention so to do. The notice must state the name and address of the person, or, if a firm, the name and address of the firm, and must be signed by the person or firm, or his or their solicitor (if any) and must be served, or, if posted, must be sent by post in sufficient time to reach the abovenamed not later than 4.00 o'clock in the afternoon of 11 August 1982 (the day before the day appointed for the hearing of the petition). 1512

In the Supreme Court of Victoria—In the matter of the Companies (Victoria) Code; and in the matter of TEGAPHS PTY. LTD.

Notice is hereby given that a petition for the winding up of the abovenamed Company by the Supreme Court was on 8 July 1982 presented by Eric John Unger, Deputy Commissioner of Taxation of the Commonwealth of Australia and that the said petition is directed to be heard before the Court sitting at the Fifteenth Court, Law Courts, Lonsdale Street, Melbourne, at the hour of 10.30 o'clock in the forenoon on 12 August 1982 and any creditor or contributory of the said company desiring to support or oppose the making of an order on the said petition may appear at the time of hearing by himself or his Counsel for the purpose; and a copy of the said petition will be furnished to any creditor or contributory of the said company requiring the same by the undersigned on payment of the regulated charge for the same.

The Petitioner's official address is 350 Collins Street, Melbourne.

The Petitioner's Solicitor is B. J. O'Donovan, Crown Solicitor for the Commonwealth, of 99 Queen Street, Melbourne.

B. J. O'DONOVAN

NOTE—Any person who intends to appear on the hearing of the said petition must serve on or send by post to the abovenamed B. J. O'Donovan notice in writing of his intention so to do. The notice must state the name and address of the person, or, if a firm, the name and address of the firm, and must be signed by the person or firm, or his, or their solicitor (if any), and must be served, or, if posted, must be sent by post in sufficient time to reach the abovenamed not later than 4.00 in the afternoon of 11 August 1982. 1516

In the Supreme Court of Victoria—In the matter of the Companies (Victoria) Code; and in the matter of DEBONAIRE AIR CONDITIONING PROPRIETARY LIMITED

Notice is hereby given that a petition for the winding up of the abovenamed Company by the Supreme Court was on 8 July 1982 presented by Eric John Unger, Deputy Commissioner of Taxation of the Commonwealth of

Australia and that the said petition is directed to be heard before the Court sitting at the Fifteenth Court, Law Courts, Lonsdale Street, Melbourne, at the hour of 10.30 o'clock in the forenoon on 12 August 1982 and any creditor or contributory of the said company desiring to support or oppose the making of an order on the said petition may appear at the time of hearing by himself or his Counsel for the purpose; and a copy of the said petition will be furnished to any creditor or contributory of the said company requiring the same by the undersigned on payment of the regulated charge for the same.

The Petitioner's official address is 350 Collins Street, Melbourne.

The Petitioner's Solicitor is B. J. O'Donovan, Crown Solicitor for the Commonwealth, of 99 Queen Street, Melbourne.

B. J. O'DONOVAN

NOTE—Any person who intends to appear on the hearing of the said petition must serve on or send by post to the abovenamed B. J. O'Donovan notice in writing of his intention so to do. The notice must state the name and address of the person, or, if a firm, the name and address of the firm, and must be signed by the person or firm, or his, or their solicitor (if any), and must be served, or, if posted, must be sent by post in sufficient time to reach the abovenamed not later than 4.00 in the afternoon of 11 August 1982. 1517

In the Supreme Court of Victoria—In the matter of the Companies (Victoria) Code; and in the matter of GRANGE PRINTING PTY. LTD.

Notice is hereby given that a petition for the winding up of the abovenamed Company by the Supreme Court was on 8 July 1982 presented by Eric John Unger, Deputy Commissioner of Taxation of the Commonwealth of Australia and that the said petition is directed to be heard before the Court sitting at the Fifteenth Court, Law Courts, Lonsdale Street, Melbourne, at the hour of 10.30 o'clock in the forenoon on 12 August 1982 and any creditor or contributory of the said company desiring to support or oppose the making of an order on the said petition may appear at the time of hearing by himself or his Counsel for the purpose; and a copy of the said petition will be furnished to any creditor or contributory of the said company requiring the same by the undersigned on payment of the regulated charge for the same.

The Petitioner's official address is 350 Collins Street, Melbourne.

The Petitioner's Solicitor is B. J. O'Donovan, Crown Solicitor for the Commonwealth, of 99 Queen Street, Melbourne.

B. J. O'DONOVAN

NOTE—Any person who intends to appear on the hearing of the said petition must serve on or send by post to the abovenamed B. J. O'Donovan notice in writing of his intention so to do. The notice must state the name and address of the person, or, if a firm, the name and address of the firm, and must be signed by the person or firm, or his, or their solicitor (if any), and must be served, or, if posted, must be sent by post in sufficient time to reach the abovenamed not later than 4.00 in the afternoon of 11 August 1982. 1518

GLADYS COOPER MUNTZ, formerly of Ellerslie, 16 Harcourt Street, Hawthorn, but late of Kambermere Private Nursing Home, 23 Derby Street, Camberwell, widow, DECEASED

Creditors, next of kin and others having claims in respect of the estate of the deceased who died on 8 March 1982 are required by The Perpetual Executors and Trustees Association of Australia Limited of 50 Queen Street, Melbourne to send particulars of their claims to the said Company by 30 September 1982 after which date it will convey or distribute the assets, having regard only to the claims of which the Company then has notice.

JAMES HOPPER, solicitor, 409 Whitehorse Road, Balwyn 1440

JAMES LEONARD ELLIOTT (in Will called James Elliott), formerly of Swan Hill, in the State of Victoria, but late of Nurrawee, in the said State, retired contractor, DECEASED (who died on 19 February 1982).

Creditors, next of kin and all other persons having claims against the Estate of the deceased are required by the Executors of the Will, Alice Valencia Elliott and Thomas Bridson Green, to send particulars to them care of the undersigned on or before 9 September 1982, after which date they will distribute the assets having regard only to the claims of which they then have notice.

GARDEN & GREEN, solicitors, 4 McCallum Street,
Swan Hill 1441

RUBY MAY WEEKS, late of Bendigo Home and Hospital for the Aged, Barnard Street, Bendigo, widow, DECEASED

Creditors, next of kin and others having claims against the Estate of the abovenamed deceased who died on 2 April 1982 are required to send particulars thereof to National Trustees Executors and Agency Company of Australasia Limited of 46 Queen Street, Bendigo on or before 15 September 1982 after which date the said Company will distribute the assets of the said deceased having regard only to the claims of which it then has notice 1442

Creditors, next of kin and others having claims against the Estate of John Gordon late of Flat 12, 1231 Malvern Road, Malvern in the State of Victoria, Company Director deceased who died on 17 October 1981 are required to send particulars of their claims to the Executor Kathleen Gordon of care of the undermentioned Solicitors on or before 29 July 1982 after which date the Executor will distribute the assets of the estate having regard only to the claims of which he shall then have notice.

SACKVILLE, WILKS & CO., solicitors, 100 Collins Street, Melbourne 1443

Creditors, next of kin and others having claims in respect of the Estate of John Royce Evans late of 137 Perry Street, Alphington in the State of Victoria, Gentleman, deceased who died on 30 January 1982, are to send particulars of their claims to The Equity Trustees Executors and Agency Company Limited of 472 Bourke Street, Melbourne, the Executor appointed in the deceased's Will, by 15 September 1982, after which date the said company will distribute the assets having regard only to the claims of which it shall then have had notice.

WILLIAM M. SERONG, solicitor, 274 Queens Parade, Clifton Hill, Vic. 3068 1444

Creditors, next of kin and others having claims in respect of the Estate of Leonard Robert Barker late of 1/20 Auburn Grove, Hawthorn Retired deceased who died on 21 May 1982 are to send particulars of their claims to the Executor Gordon David Maurice Goldberg of 305 Bridge Road, Richmond Solicitor care of the undersigned Solicitors by 15 September 1982 after which date the Executor will distribute the assets having regard only to the claims of which he has then had notice.

JOSEPH LYNCH & WINDOW, solicitors, 299 Bridge Road, Richmond 1459

Creditors, next of kin and others having claims against the estate of Howard William Pitcher late of 23 Glen Avenue, Croydon in the State of Victoria, Retired Bank Officer deceased, who died on 18 January 1982 are required by the executor National Trustees Executors and Agency Company of Australasia Limited of 95 Queen Street, Melbourne in the said State, to send particulars of their claims to the said executor by 15 September 1982 after which date the said executor will distribute the assets having regard only to the claims of which the said executor then has notice.

KEVIN POWER & CO., solicitors, 1st Floor, 452 Burwood Highway, Wantirna South 3152 1460

MARY VERA DAWBORN, late of 8 Clendon Court, Toorak, in the State of Victoria, widow, DECEASED

Creditors, next of kin and others having claims in respect of the estate of the deceased, who died on 28 April 1982 are required by the Executors John Kingsley Dawborn of 20 Highfield Road, Canterbury Medical Practitioner, Anne Josephine Kingsley Dawborn of 8 Clendon Court, Toorak Occupational Therapist and The Union-Fidelity Trustee Company of Australia Limited of 100 Exhibition Street, Melbourne to send particulars of their claims to them at 100 Exhibition Street, Melbourne by 16 September 1982 after which date they will distribute and/or convey the assets amongst the persons entitled thereto having regard only to the claims of which they then have notice.

RICHARD K. PITMAN, LL.B., solicitor, of corner of Kingsway and Railway Parade, Glen Waverley 3150 1461

Creditors, next of kin and others having claims in the Estate of Alice Margaret Letts late of Unit 5, 28 Grandview Street, Glenroy, in the State of Victoria, Gentlewoman deceased, who died on 8 April 1982 are to send particulars of their claims to the executrices Irene Margaret Royal and Kathleen Beech care of their Solicitors Le Grand, Randles, Adams & Co. of 644 Sydney Road, Brunswick, by 14 September 1982, after which date they will distribute the assets having regard only to the claims of which they then have notice.

LE GRAND, RANGLES, ADAMS & CO., 644 Sydney Road, Brunswick, the solicitors for the applicant 1462

EDNA JOSEPHINE LAW, late of 22 Abbey Walk, East Vermont, in the State of Victoria, widow, DECEASED

Creditors, next of kin and others having claims against the Estate of the said deceased who died on 8 April 1982 are to send particulars of their claims to Norman Michael Law and Patricia Joan Winter, care of Messrs Mulcahy Mendelson & Round, Solicitors of 536 Whitehorse Road, Mitcham by 30 September 1982 after which date they will distribute the assets having regard only to the claims of which they then have notice.

MULCAHY MENDELSON & ROUND, solicitors, 536 Whitehorse Road, Mitcham 1463

AGNES MONTEITH NEELY, late of 6 Kitchen Street, Mansfield, widow, DECEASED

Creditors, next of kin and others having claims in respect of the deceased who died on 25 December 1981 are required by her Trustees Robert John Neely of 24 Reynolds Street, Mansfield Manager and Douglas Monteith Neely of 20 Marina Drive, Melton Manager to send particulars to them care of the undermentioned firm of Solicitors by 29 September 1982 after which date the Trustees may convey and distribute the assets having regard only to the claims of which they then have notice.

Messrs MAL. RYAN, JACKSON & GLEN, 9 High Street, Mansfield, solicitors for the trustees 1464

Creditors, next of kin and others having claims against the Estate of James Patrick Torpey deceased late of 10 Hollick Street, Richmond in the State of Victoria, Retired, who died on 29 March 1982 are required to send particulars of their claims to the Executor Kevin Daniel Torpey care of the undermentioned solicitors on or before 29 July 1982, after which date the Executor will distribute the assets of the estate having regard only to the claims of which he shall then have notice.

SACKVILLE, WILKS & CO., solicitors, 100 Collins Street, Melbourne 1538

In the Will of ETHEL HORE, late of Gringegalgon, R.S.D., 57 Coleraine, in the State of Victoria, widow, DECEASED

Creditors, next of kin and others having claims against the Estate of the said deceased who died on 2 May 1982 are to send particulars of their claims to Margaret Delange c/- Mulcahy Mendelson & Round solicitors of 536 Whitehorse Road, Mitcham 3132 by 30 September 1982 after which date they will distribute the assets having regard only to the claims of which they then have notice.

MULCAHY MENDELSON & ROUND, solicitors, 536 Whitehorse Road, Mitcham, Victoria 1540

REGINALD MAXFIELD BREWER, late of Chelvey Hollow, Chelvey Batch, Brockley, Bristol, United Kingdom, retired legal clerk, DECEASED

Creditors, next of kin and others having claims in respect of the estate of the deceased who died on 8 October 1981 are required by The Trustees Executors & Agency Co. Ltd. of 401 Collins Street, Melbourne the duly constituted attorney of David Wallace Williams and Richard Kennedy Harvey Gaskell both of 17 Small Street, Bristol United Kingdom the Executors of the Will of the deceased to send particulars to them care of the undermentioned solicitors by 18 September 1982 after which date The Trustees Executors & Agency Co. Ltd. may convey or distribute the assets having regard only to the claims of which they then have notice.

HADEN SMITH & FITCHETT, solicitors, 423 Bourke Street, Melbourne 1556

MARJORIE SMITH, late of Beach House, 81 Nepean Highway, Seaford, widow, DECEASED

Creditors, next of kin and others having claims in respect of the estate of the deceased (who died on 8 April 1982) are required by The Perpetual Executors and Trustees Association of Australasia Limited of 50 Queen Street, Melbourne, to send particulars of their claims to the said Company by 23 September 1982 after which date it will convey or distribute the assets, having regard only to the claims of which the Company then has notice.

DARVALL McCUTCHEON, solicitors, 80 Collins Street, Melbourne 1523

ERNEST CLAUDE HAMILTON BARTLETT, late of 11 Wave Street, Elwood, gentleman, DECEASED

Creditors, next of kin and others having claims in respect of the estate of the deceased who died on 18 May 1982 are required by National Trustees Executors and Agency Company of Australasia Limited of 95 Queen Street, Melbourne, to send particulars to it by 16 September 1982 after which date it may convey or distribute the assets having regard only to the claims of which it then has notice.

J. A. REDMOND, MARTIN & CAMERON, solicitors, 472 Bourke Street, Melbourne 1524

Creditors, next of kin and others having claims in respect to the estate of Marjorie Emily Williams late of 12 Longmore Street, West St. Kilda, home duties deceased who died on 25 April 1982 are required to send particulars of their claims to National Trustees Executors and Agency Company Limited of 95 Queen Street, Melbourne, the Executor appointed by the deceased's Will by 22 September 1982 after which date it will distribute the assets having regard only to the claims of which it then has notice.

G. R. HERBERT & CO., solicitors, 612-614 Balcombe Road, Black Rock 1525

MARY McDONALD, late of Pineville Private Nursing Home, 2 Gertrude Street, Geelong West, in the State of Victoria, widow, DECEASED

Creditors, next of kin and others having claims in respect of the estate of the deceased who died on 6 January 1982 are required by the personal representative The Union-Fidelity Trustee Company of Australia Limited of 100 Exhibition Street, Melbourne, to send particulars to its Melbourne office by 30 September 1982 after which date the personal representative may convey or distribute the assets having regard only to the claims of which it then has notice.

WHYTE JUST & MOORE, solicitors, 27 Malop Street, Geelong 1508

JOHN DAVID FREW, late of Yaapeet, in the State of Victoria, farmer, DECEASED

Creditors, next of kin and others having claims in respect of the estate of the abovenamed deceased who died on 23 December 1981 are required by the trustee the Union-Fidelity Trustee Company of Australia Limited of 101 Lydiard Street North Ballarat in the said State to send particulars to it by 24 September 1982 after which date the trustee may convey or distribute the assets having regard only to the claims of which it then has notice.

ENTWISLE, ROBINSON & CO., solicitors, of 58 Federal Street, Rainbow, 3424 1509

ROSE HANNAH AYRES, formerly of Langville, in the State of Victoria, married woman, but late of Kerang, in the said State, widow, DECEASED

Creditors, next of kin and all other persons having claims against the estate of the said Deceased are required by Terry Robert Ayres of 19 Croton Street, Kerang aforesaid carpenter the Administrator of the estate of the said deceased to send particulars of such claims to him in care of the undermentioned Solicitors on or before 20 September 1982 after which date he will distribute the assets having regard only to the claims to which he then has notice.

BASILE & CO., barristers and solicitors, 46 Wellington Street, Kerang, Vic. 3579 1510

CHARLES VICTOR SHAW, late of 25 Murray Street, Warrnambool, retired gardener, DECEASED

Creditors, next of kin and all others having claims in respect of the abovenamed deceased (who died on 22 April 1982) are required to send particulars of their claims in writing to the Executor Laurence Keith Hose of 42 Hyland Street, Warrnambool care of the undersigned on or before 16 September 1982 after which date he will distribute the assets of the said estate having regard only to the claims of which he then has notice as aforesaid.

DESMOND DUNNE & DWYER, solicitors, Warrnambool 1511

Creditors, next of kin and others having claims in respect of the estate of Greta Gladstone Voros late of 102 Mt. Dandenong Road, East Ringwood in the State of Victoria widow deceased who died on 8 June 1982 are to send particulars of their claims to The Trustees Executors and Agency Company Limited of 401 Collins Street, Melbourne by 17 September 1982 after which date it will distribute the assets having regard only to the claims of which it then has notice.

WILLIAM HARRISON & SON, solicitors, 401 Collins Street, Melbourne 1528

LOUISA ELIZABETH SMITH, late of 6 Temple Street, West Brunswick, in the State of Victoria, widow, DECEASED

Creditors, next of kin and others having claims in respect of the estate of the abovenamed deceased who died on 17 September 1981 are required by Kenneth Edward Chilcott of 229 Melville Road, Pascoe Vale South Solicitor the Executor of the Will of the said deceased to send particulars of their claims to the said Executor care of the undernamed Solicitor by 14 September 1982 after which date he will convey or distribute the assets having regard only to the claims of which he then has notice.

Wednesday, 14 July 1982.

K. E. CHILCOTT, Esq., solicitor, 229 Melville Road, Pascoe Vale South, 3044 1536

DORIS VIOLET BELL, late of 19 Paterson Street, Carrum, widow, DECEASED

Creditors, next of kin and others having claims in respect of the estate of the deceased who died on 21 August 1981 are required by the Trustee National Trustees Executors and Agency Company of Australasia Limited of 95 Queen Street Melbourne to send particulars to it by 27 September 1982 after which date the Trustee may convey or distribute the assets having regard only to the claims of which it then has notice.

MACOBOY, TAYLOR & TAYLOR, solicitors, 32 View Street, Bendigo 1537

BERTHA MARION COATES, late of St. Ives Private Nursing Hospital, 118 Vale Street, East Melbourne, widow, DECEASED

Creditors, next of kin and others having claims in respect of the estate of the deceased who died on 28 December 1981 are required by National Trustees Executors and Agency Company of Australasia Limited of 95 Queen Street Melbourne to send particulars of their claims to the said Company by 21 September 1982 after which date it will convey or distribute the assets, having regard only to the claims of which the Company then has notice.

B. T. E. FLYNN, MURONE & CO., solicitors, 125 Bell Street, Coburg 1465

GEORGE JENNINGS, late of Unit 3, No. 11 Allambee Avenue, Camberwell, in the State of Victoria, gentleman, DECEASED

Creditors, next of kin and others having claims in respect of the estate of the above named deceased (who died on 2 March 1982) are required to send particulars of their claims to the Executors of the Will National Trustees Executors and Agency Company of Australasia Limited and Peter James Jennings care of the said National Trustees Executors and Agency Company of Australasia Limited at 95 Queen Street Melbourne in the State of Victoria on or before 16 September 1982 after which date the Executors will distribute the assets of the said deceased having regard only to the claims of which they then have notice.

PETER HASSETT & CO., solicitors, of 1156 Toorak Road, Hartwell 1481

CLIVE FRANCIS GORDON, late of Cohuna, in the State of Victoria, welder, DECEASED

Creditors, next of kin and all other persons having claims against the said Deceased are required by Pauline Anne Gordon of 13 George Street, Cohuna aforesaid Widow the Executrix of the Estate of the said Deceased to send particulars of such claims to her in care of the under-mentioned Solicitors on or before 15 September 1982 after which date she will distribute the assets having regard only to the claims to which she then has Notice.

WILLAN & MCKENZIE, solicitors, Cohuna, 3568 1482

ROBERT FRANCIS CONNELL, late of Yarrawonga, in the State of Victoria, dairy employee

Creditors, next of kin and others having claims in respect of the Estate of the Deceased, who died on 4 June 1982, are required by Elizabeth Mary Connell of 38 Lynch Street, Yarrawonga, and Michael Ignatius Connell of R.M.B. 2170, Yarrawonga, the Executors of the Will of the late Robert Francis Connell to send particulars to them by 1 September 1982, after which date the Executors may convey or distribute the assets, having regard only to the claims of which they then have notice.

Dated 2 July 1982

HARGREAVES, solicitors, 81 Belmore Street, Yarrawonga 1483

Creditors, next of kin and others having claims in respect of the estate of Alice Beatrice Brown late of Yarrawonga in the State of Victoria, Widow, who died on 5 July 1982 are to send particulars of their claims to Elva Jean Bellis and Stella Merle Hobson care of the under-mentioned Solicitors by 14 September 1982 after which date they will distribute the assets having regard only to the claims of which they then have notice.

Dated 8 July 1982

HARGREAVES, solicitors, 81 Belmore Street, Yarrawonga 3730 1484

MARY ISABEL JARDINE, late of 10 Grimes Road, Point Lonsdale, gentlewoman, DECEASED

Creditors, next of kin and others having claims in respect of the estate of the deceased who died on 19 April 1982 are requested to send particulars of their claims to the Executors Douglas Robinson McIndoe and Victor Shalliker care of the undersigned Solicitors by 30 September 1982 after which date the Executors will proceed to distribute the estate having regard only to the claims of which they then have notice.

DOYLES, 69 Moorabool Street, Geelong 1485

Creditors, next of kin and others having claims in respect of the estate of Frank Braddick late of 13 Naples Street, Box Hill South, stevedore, deceased who died on 3 April 1982 are required to send particulars of their claims to the Executrix, Lois Braddick, of 13 Naples Street, Box Hill South, by 14 September 1982 after which date the Executrix will distribute the assets having regard only to the claims of which she then has notice.

LOIS BRADDICK, 13 Naples Street, Box Hill South 1488

Creditors, next of kin and others having claims in respect of the estate of Reginald Myles Ansett late of Gunyong Valley, Mount Eliza, deceased who died on 23 December 1981 are required to send particulars of their claims to Joan McAuliffe Ansett, Theodore Hertzl Moss, John Keith Simpson and the Equity Trustees Executors and Agency Company Limited the Executors care of the under-mentioned Solicitors by 15 September 1982 after which date the Executors will distribute the assets having regard only to the claims of which they then have notice.

CLARKE RICHARDS GRANT & CO., solicitors, 350 La Trobe Street, Melbourne 1491

Creditors, next of kin and others having claims in respect of the estate of Georgina Amelia Atkinson late of Hilltop Crescent, Mount Evelyn Retired Stenographer deceased who died on 9 January 1982 are to send particulars of their claims to National Trustees Executors and Agency Company of Australasia Limited of 95 Queen Street, Melbourne by 14 September 1982 after which date it will distribute the assets having regard only to the claims of which it then has notice.

COLTMANS, solicitors, 367 Collins Street, Melbourne 1497

Creditors, next of kin and others having claims in respect of the estate of Winifred Goble late of Unit 8, 1 Coles Court, Beaumaris, Widow deceased who died on 30 April 1982 are required to send particulars of their claims to The Equity Trustees Executors and Agency Company Limited of 472 Bourke Street, Melbourne the Executor appointed by the deceased's Will by 22 September 1982 after which date it will distribute the assets having regard only to the claims of which it then has notice.

G. R. HERBERT & CO., solicitors, 612-614 Balcombe Road, Black Rock 1522

In the Supreme Court of the State of Victoria
SALE BY THE SHERIFF

On 26 August 1982 at 2.30 p.m. at the Sheriff's Office, Writs and Warrants Division, 2nd Floor, 241 William Street, Melbourne (unless process be stayed or satisfied).

All the Estate and Interest (if any) of Mavona Nominees Pty. Ltd. of 406 Lonsdale Street, Melbourne as proprietor of an estate in fee simple in the land described in Certificate of Title Volume 8946 Folio 297 which is vacant land with some foundations known as No. 54 Illawarra Crescent, North Dandenong.

Registered Mortgage No. G.883850 affects the said estate and interest.

Terms—Cash only

1557 R. J. MARTIN, Sheriff's Officer

In the Supreme Court of the State of Victoria
SALE BY THE SHERIFF

On 2 September 1982 at 2.30 p.m. at Sheriff's Office, Writs and Warrants Division, 2nd Floor, 241 William Street, Melbourne (unless process be stayed or satisfied).

All the Estate and Interest (if any) of Gaetano Vito Di Pasquale of 25 Oak Street, Hawthorn as joint proprietor with Cheryl Dawn Di Pasquale of an estate in fee simple in the land described in Certificate of Title Volume 3490 Folio 927 upon which is erected a white single storey double fronted solid brick Victorian House known as No. 25 Oak Street Hawthorn.

Registered Mortgage Nos. F.906645 and J.542458 affect the said estate and interest.

Terms—Cash only

1558 R. J. MARTIN, Sheriff's Officer

**NOTICE OF MAKING OF
STATUTORY RULES
WHICH ARE NOT YET
AVAILABLE**

Notice is given of the making of the following Statutory Rules:

- No. *Companies (Application of Laws) Act 1981*
197/1982. *Companies (Application of Laws) Regulations 1982*
- Companies (Application of Laws) Act 1981*
198/182. *Companies (Application of Laws—Regulations) Regulations 1982*
- Companies (Application of Laws) Act 1981*
199/1982. *Companies (Application of Laws—Transitional Provisions) Regulations 1982*
- National Companies and Securities Commission (State Provisions) Act 1981*
202/1982. *National Companies and Securities Commission (State Provisions) Regulations 1982*
- *Education Service Act 1981*
204/1982. *Education Service (Amendment No. 2) Regulations 1982*
- Wildlife Act 1975*
205/1982. *Wildlife (Hog Deer Tag) (Amendment No. 1) Regulations 1982*
- Workers Compensation Act 1958*
207/1982. *Workers Compensation (Amendment) Regulations 1982*
- Pay-roll Tax Act 1971*
208/1982. *Pay-roll Tax Regulations 1982*
- Supreme Court Act 1958*
209/1982. *Solicitors' Renumeration Order 1982*
- Melbourne and Metropolitan Board of Works Act 1958*
210/1982. *Special By-Law No. 24—Water Supply to Non-Rateable Property*
- Swan Hill Pioneer Settlement Act 1974*
211/1982. *Swan Hill Pioneer Settlement Authority (Amendment) Regulations 1982*
- Port of Portland Authority Act 1958*
212/1982. *Port of Portland Authority (Amendment No. 40) Regulations 1982*
- Public Service Act 1974*
213/1982. *Public Service Amendment Regulations (No. 10) 1982*
- Dental Technicians Act 1972*
214/1982. *Advanced Dental Technicians (Licence Fees) Regulations 1982*
- Industrial Safety, Health and Welfare Act 1981*
215/1982. *Industrial Safety Health and Welfare (Machinery) Regulations 1982*
- Industrial Safety, Health and Welfare Act 1981*
216/1982. *Industrial Safety Health and Welfare (General Safety) Regulations 1982*
- Industrial Safety, Health and Welfare Act 1981*
217/1982. *Industrial Safety, Health and Welfare (Tractor Safety) Regulations 1982*
- Industrial Safety, Health and Welfare Act 1981*
218/1982. *Industrial Safety, Health and Welfare (Factories, Shops, Offices and Warehouses) (Amendment) Regulations 1982*
- No. *Industrial Safety, Health and Welfare Act 1981*
219/1982. *Industrial Safety, Health and Welfare (Factories) (Amendment) Regulations 1982*
- Industrial Safety, Health and Welfare Act 1981*
220/1982. *Industrial Safety, Health and Welfare (Timber Industry Forest Operations) Regulations 1982*
- Health Act 1958*
221/1982. *Health (Swimming Pools Water Purification) Regulations 1982*
- Health Act 1958*
222/1982. *Health (Registration Extracts) Regulations 1982*
- Building Control Act 1981*
223/1982. *Uniform Building (Amendment) Regulations 1982, No. 15*
- Local Government Act 1958*
224/1982. *Local Government (House Builders' Liability) (Forms) Amendment Regulations 1982*
- Building Control Act 1981*
225/1982. *Building Control (House Builders' Liability) (Declaration Forms) Regulations 1982*
- Building Control Act 1981*
226/1982. *Uniform Plumbing and Sewerage (Amendment) Regulations 1982, No. 2*
- Building Control Act 1981*
227/1982. *Building Control (Fees) Regulations 1982*
- Building Control Act 1981*
228/1982. *Uniform Building (Amendment) Regulations 1982, No. 16*
- Motor Car Act 1958*
229/1982. *Motor Car (Transfer and Roadworthiness) (Certificates of Roadworthiness) (Fees) Regulations 1982*
- Marine Act 1958*
230/1982. *Amendment To Port Rule (Management of Slipways) 1974*
- State Bank Act 1958*
231/1982. *State Bank (Interest Rates Amendment No. 11) General Orders 1982*

**NOTICE OF MAKING AND
AVAILABILITY OF
STATUTORY RULES**

In pursuance of the provisions of the *Subordinate Legislation Act 1962* and the Regulations made thereunder notice is given of the making and availability of the following Statutory Rules:

- | No. | Weights and Measures Act 1958 | Price |
|-----------|----------------------------------------------------------------------------------------------|-------|
| 181/1982. | <i>Weights and Measures (Amendment No. 16) Regulations 1982</i> | 20c |
| | <i>State Bank Act 1958</i> | |
| 184/1982. | <i>State Bank (Interest Rates Amendment No. 10) General Orders 1982</i> | 20c |
| | <i>Wildlife Act 1975</i> | |
| 186/1982. | <i>Dutson Downs Wildlife Management Co-operative Area (Amendment No. 1) Regulations 1982</i> | 20c |
| | <i>Local Government Act 1958</i> | |
| 192/1982. | <i>Municipal Clerks Board (Amendment) Regulations 1982, No. 1</i> | 20c |

No.	Police Regulation Act 1958	Price	1. Matter submitted to the Executive Council
194/1982.	Police (Constitution Strength Organization and Seniority) (Amendment No. 4) Regulations 1982	20c	Matter, submitted to the Executive Council which requires gazettal will normally be published in the issue of the following week.
200/1982.	Companies (Application of Laws) Act 1981 Companies (Application of Laws—Fees) Regulations 1982	20c	Where urgent gazettal is required, special arrangements should be made with the Gazette officer, Department of the Premier, Third Floor, 1 Treasury Place, Melbourne. Telephone: 651 1706.
201/1982.	Securities Industry (Application of Laws) Act 1981 Securities Industry (Application of Laws—Regulations) Regulations 1982	20c	2. Other matter
203/1982.	Companies (Acquisition of Shares) (Application of Laws) Act 1981 Companies (Acquisition of Shares) (Application of Laws—Regulations) Regulations 1982	20c	(a) All other matter duly certified by a responsible officer for publication should be lodged with the Gazette Officer not later than half-past Nine a.m. on Tuesday.
206/1982.	Wildlife Act 1975 Wildlife (Game) (Amendment No. 1) Regulations 1982	20c	(b) Lengthy or involved notices should be forwarded several days before publication.
			(c) Proofs, which will be supplied only when specifically requested or at the direction of the Gazette Officer, should be returned promptly to avoid delay in publication.
			(d) No additions or amendments to matters for publication will be accepted by telephone.

Copies of these Statutory Rules are available and may be purchased at the Victorian Government Bookshop, located at 7A Parliament Place, Melbourne, 3002. If ordered by mail, remittance should be addressed to "The Government Printer, Box 203, North Melbourne, 3051", and should include 50c delivery and handling fee.

The annual subscription rates for Statutory Rules for the year commencing 1 January 1982, payable in advance are as follows:

*Statutory Rules (other than Public Service Determinations), Pamphlet copies only \$55.00
Public Service Determinations \$33.00

*The Bound Volume of Statutory Rules is not included in the subscription rate.

F. D. ATKINSON
Government Printer

THE "VICTORIA GOVERNMENT GAZETTE"

PUBLICATION—A VICTORIA GOVERNMENT GAZETTE is published every WEDNESDAY EVENING unless advertised otherwise.

SUBSCRIPTIONS—The annual subscription rate, including postage, is \$80, payable in advance.

PRIVATE ADVERTISEMENTS—Advertisements will be received by the Government Printer not later than the day preceding publication—at ordinary rates at or before ONE p.m. and at double rates between ONE p.m. and HALF PAST THREE p.m. The charge for ADVERTISEMENTS is \$1 per line single column and \$2 per line double column. The charge for a full page is \$150. The title forms one or more lines as a heading. On an average ten words make a line of single column. Every signature must likewise be counted as a line. The final words of a paragraph though only portion of a line, must be counted as one line. Signatures (in particular) and proper names must be written very clearly in the text: ONE SIDE ONLY of each sheet of paper should be written upon.

All documents NOT CLEARLY PREPARED will be returned unpublished. Where brands occur, not provided for by the ordinary letters of the alphabet, a written explanatory description also must be furnished.

PAYMENTS—Unless the advertiser has a Credit Account, all payments are required in advance. Remittances should be made by cheque, postal order or money order, payable to "GOVERNMENT PRINTER".

CORRESPONDENCE—All correspondence should be addressed to "The Victorian Government Printer, P.O. Box 203, North Melbourne, 3051".

PUBLICATION OF OFFICIAL MATTER

Attention is invited to the following procedure in relation to the publication of official matter in the Government Gazette:

Publication will be facilitated by the submission of carbon copies for the use of the Gazette officer.

AGENTS FOR THE "VICTORIA GOVERNMENT GAZETTE"

The following have been appointed agents to receive Advertisements and Subscriptions for the Victoria Government Gazette:

ARMSTRONG'S COMMUNICATIONS PTY. LTD., 191 Queen Street, Melbourne, Victoria 3000.

ARNALL & JACKSON, 390 Barkly Street, Brunswick, Victoria 3056.

BAIRNSDALE AUTHORIZED NEWSAGENCY, 132 Main Street, Bairnsdale, Victoria 3875.

BENALLA AUTHORIZED NEWSAGENCY, 45 Bridge Street, Benalla, Victoria 3672.

BLANE'S AUTHORIZED NEWSAGENTS, 162 Murray Street, Colac, Victoria 3250.

CARTER, R. G., ADVERTISING SERVICE PTY. LTD., 129 Church Street, Hawthorn, Victoria 3122.

CORNELL, R. G., 126 Eighth Street, Mildura.

FAROE, S. W. & E. P., 79 Henty Street, Casterton, Victoria 3311.

FRANKS, H., & CO., 184 Ryrie Street, Geelong, Victoria 3220.

GORDON & GOTCH AUSTRALASIA LTD., 25-37 Huntingdale Road, Burwood, Victoria 3125.

HARSTON, PARTRIDGE & CO., PTY. LTD., 455 Little Collins Street, Melbourne, Victoria 3000.

KYNETON GUARDIAN PTY. LTD., P.O. Box 18, Kyneton, Victoria 3444.

LONSDALE NEWSAGENCY, 250 Lonsdale Street, Dandenong, Victoria 3175.

LOVELL'S SHEPPARTON NEWSAGENCY, 246 Wyndham Street, Shepparton, Victoria 3630.

THE MERCANTILE EXCHANGE, 50 Queen Street, Melbourne, Victoria 3000.

MCDONALD'S NEWSAGENCY, 88 Bridge Street, Ballarat, Victoria 3350.

MCGILL'S AUTHORIZED NEWSAGENCY, 183-185 Elizabeth Street, Melbourne, Victoria 3000.

MCAUGHTON, P. R. & L. A., 112-114 Gray Street, Hamilton, Victoria 3300.

POWNEY'S AUTHORIZED NEWSAGENCY, 293 Hargreaves Street, Bendigo, Victoria 3550.

PURDIE, J., & CO., 138 Moorabool Street, Geelong, Victoria 3220.

SALE AUTHORIZED NEWSAGENCY, 292-294 Raymond Street, Sale, Victoria 3850.

VERNONS OF RICHMOND, 261 Bridge Road, Richmond, Victoria 3121.

CONTENTS

	Page
Appointments	2348
Cemeteries—Scale of Fees	2342
Contracts	2345
Estates of Deceased Persons	2332
Government Notices	2332
Lands	2363
Melbourne and Metropolitan Board of Works— Notice	2341
Minerals and Energy	2347
Notice of Making of Statutory Rules	2384
Orders in Council—	
Acts—Local Government; Crown Land (Re- serves); Superannuation; Land; Water; Cemeteries; Port of Portland Auth- ority; Historic Buildings; Geelong Waterworks and Sewerage; Housing; Mildura Irrigation and Water Trusts; Latrobe Valley; Building Societies; Superannuation; Sewerage Districts; Water.	2349 et seq
Private Advertisements	2366
Proclamations	2331
Public Holidays	2331
Resignations	2349
Tenders	2365
Transport Regulation Board—Public Hearings	2335
Waterworks Trust	2341