



[2615]

PUBLISHED BY AUTHORITY
Victoria Government Gazette

No. 81—Wednesday, 24 August 1983

PROCLAMATIONS

Public Highway—CITY OF DONCASTER AND
TEMPLESTOWE

PROCLAMATION

By His Excellency the Governor of the State of Victoria and its Dependencies in the Commonwealth of Australia, &c., &c., &c.

Whereas by the *Local Government Act 1958*, section 519 it is amongst other things enacted that it shall be lawful for the Governor in Council at any time and from time to time upon the request of the council of any municipality by notice in the *Government Gazette* to proclaim any land reserved used or by purchase or exchange acquired for a street road highway thoroughfare bridge square court alley or right-of-way or any street road lane or passage made or laid out or proposed to be made or laid out on any land of which a plan of subdivision delineating that street road lane or passage has been sealed with the seal of the municipality under subdivision (3) of Division 9 of Part XIX of the *Local Government Act 1958* or a corresponding previous enactment to be a public highway and that such land shall thereupon and thenceforth from the date of such proclamation become and be absolutely dedicated to the public as a public highway within the meaning of any law then or thereafter in force.

And whereas the Council of the City of Doncaster and Templestowe has requested that the land hereinafter mentioned, being a street road lane or passage made or laid out or proposed to be made or laid out on land of which a plan of subdivision delineating such street road lane or passage has been sealed with the seal of the municipality under subdivision (3) of Division 9 of Part XIX of the *Local Government Act 1958*, or a corresponding previous enactment be so declared to be a public highway.

Now therefore, I, the Governor of the State of Victoria in the Commonwealth of Australia, by and with the advice of the Executive Council of the said State, do by this proclamation declare that Larne Avenue, Donvale coloured brown on Plan of Subdivision No. 50676 lodged in the Office of Titles shall be a public highway within the meaning of the said Act.

Given under my Hand and the Seal of the State of Victoria aforesaid, at Melbourne, this twenty-third day of August, in the year of Our Lord One thousand nine hundred and eighty-three, and in the thirty-second year of the reign of Her Majesty Queen Elizabeth the Second, Queen of Australia.

(L.S.)

BRIAN MURRAY

By His Excellency's Command

F. N. WILKES

Minister for Local Government

GOD SAVE THE QUEEN!

Vegetation and Vine Diseases Act 1958

REVOCATION OF PROCLAMATIONS DECLARING
PROCLAIMED AREAS FOR THE CONTROL OF FRUIT
FLY

PROCLAMATION

By His Excellency the Governor of the State of Victoria and its Dependencies in the Commonwealth of Australia, &c., &c., &c.

Whereas by the provisions of section 25 of the *Vegetation and Vine Diseases Act 1958*, it is amongst other things enacted that the Governor in Council may amend or revoke any Proclamation made in accordance with the said Act.

And whereas the provisions of section 2 of the said Act provide for the continuity of status operation or effect of any proclamation existing before the commencement of the said Act.

Now therefore I, the Governor of the State of Victoria in the Commonwealth of Australia, by and with the advice of the Executive Council thereof, do by this my Proclamation hereby revoke:

1. The proclamation made under section 3 of the *Vegetation Diseases (Fruit Fly) Act 1947* on 24 January 1956, declaring part of the Parish of Mildura to be a proclaimed area.

2. The proclamation made under section 25 of the said Act on 6 March 1963, declaring parts of the cities of Broadmeadows, Coburg and Essendon to be a proclaimed area.

3. The proclamation made under section 25 of the said Act on 7 December 1965, declaring part of the Parish of Doutra Galla in the County of Bourke, and published in the *Commonwealth Government Gazette* of October 1955 as the Melbourne Airport to be a proclaimed area.

4. The proclamation made under section 25 of the said Act on 11 May 1971, as amended by the proclamations made on 13 July 1971; 6 April 1972; and 4 July 1972; declaring parts of the Counties of Tanjil, Buln Buln, Dargo and Wonnangatta to be a proclaimed area.

5. The proclamation made under section 25 of the said Act on 1 May 1973, declaring the Rural City of Wodonga, the Shires of Towong, Upper Murray, Omeo, Tambo and Orbost, part of the Shire of Bairnsdale, Township of Bairnsdale and the Parish of Bairnsdale to be a proclaimed area.

6. The proclamation made under section 25 of the said Act on 6 April 1976, declaring the City of Sale to be a proclaimed area.

7. The proclamation made under section 25 of the said Act on 22 April 1976, declaring the City of Echuca to be a proclaimed area.

8. The proclamation made under section 25 of the said Act on 7 March 1978, declaring the Township of Myrtleford to be a proclaimed area.

9. The proclamation made under section 25 of the said Act on 6 March 1979, as amended on 12 March 1980, declaring parts of the Cities of Brunswick, Coburg, Northcote, Preston and Fitzroy to be a proclaimed area.

10. The proclamation made under section 25 of the said Act on 3 April 1979, declaring the City of Wangaratta to be a proclaimed area.

11. The proclamation made under section 25 of the said Act on 12 February 1980, declaring part of the Parish of Carlyle to be a proclaimed area.

12. The proclamation made under section 25 of the said Act on 25 March 1980, declaring the City of Benalla to be a proclaimed area.

13. The proclamation made under section 25 of the said Act on 13 January 1981, as amended on 3 March 1981, declaring parts of the Cities of Caulfield and Malvern to be a proclaimed area.

14. The proclamation made under section 25 of the said Act on 10 February 1981, declaring the Township of Yackandandah to be a proclaimed area.

15. The proclamation made under section 25 of the said Act on 24 February 1981, declaring part of the City of Nunawading to be a proclaimed area.

16. The proclamation made under section 25 of the said Act on 24 February 1981, declaring the Township of Chiltern to be a proclaimed area.

17. The proclamation made under section 25 of the said Act on 24 February 1981, declaring the Township of Tangambalanga to be a proclaimed area.

18. The proclamation made under section 25 of the said Act on 17 March 1981, declaring part of the Parish of Myrree to be a proclaimed area.

19. The proclamation made under section 25 of the said Act on 17 March 1981, declaring parts of the Cities of Melbourne, South Melbourne, Prahran and Richmond to be a proclaimed area.

20. The proclamation made under section 25 of the said Act on 17 March 1981, declaring parts of the Parishes of Dederang and Kergunyah to be a proclaimed area.

21. The proclamation made under section 25 of the said Act on 20 October 1981, declaring the Paradise Beach Estate within the Shire of Rosedale to be a proclaimed area.

22. The proclamation made under section 25 of the said Act on 12 January 1982, declaring part of the Shire of Cobram to be a proclaimed area.

23. The proclamation made under section 25 of the said Act on 26 January 1982, declaring part of the Town of Kyabram to be a proclaimed area.

24. The proclamation made under section 25 of the said Act on 3 February 1982, declaring part of the City of Kew to be a proclaimed area.

25. The proclamation made under section 25 of the said Act on 9 February 1982, declaring the area covered by the Numurkah Planning Scheme 1956 to be a proclaimed area.

26. The proclamation made under section 25 of the said Act on 17 February 1982, declaring parts of the Cities of Waverley and Oakleigh to be a proclaimed area.

27. The proclamation made under section 25 of the said Act on 10 March 1982, declaring the Town of Yarrowonga to be a proclaimed area.

28. The proclamation made under section 25 of the said Act on 30 March 1982, declaring the area within a 1 kilometre radius of the Gunbower Post Office to be a proclaimed area.

29. The proclamation made under section 25 of the said Act on 4 May 1982, declaring part of the Parish of Murrabit to be a proclaimed area.

30. The proclamation made under section 25 of the said Act on 4 May 1982, as amended on 11 May 1982, declaring part of the City of Shepparton to be a proclaimed area.

Given under my Hand and the Seal of the State of Victoria aforesaid, at Melbourne, this twenty-third day of August, in the year of Our Lord One thousand nine hundred and eighty-three, and in the thirty-second year of the reign of Her Majesty Queen Elizabeth the Second, Queen of Australia.

(L.S.)

BRIAN MURRAY

By His Excellency's Command

D. E. KENT

Minister of Agriculture

GOD SAVE THE QUEEN!

Vegetation and Vine Diseases Act 1958
DECLARING A PROCLAIMED AREA

PROCLAMATION

By His Excellency the Governor of the State of Victoria and its Dependencies in the Commonwealth of Australia, &c., &c., &c.

Whereas by section 25 of the *Vegetation and Vine Diseases Act 1958*, it is provided that where the Governor in Council is of the opinion that it is necessary to protect the fruit industry of Victoria against the introduction or spread of insects of the family Trypetidae (commonly known as fruit flies), he may by Proclamation declare any portion of Victoria specified therein to be a proclaimed area and require occupiers and owners of land in the proclaimed area to take such action for the prevention of the introduction or spread of fruit fly as is specified in the Proclamation:

Now therefore I, the Governor of the State of Victoria in the Commonwealth of Australia, being of the opinion that it is necessary to protect the fruit industry against the introduction or spread of insects of the family Trypetidae (commonly known as fruit flies) and by and with the advice of the Executive Council of the said State, do by this my Proclamation hereby —

1. Declare those portions of Victoria described in the Schedule to this Proclamation to be a proclaimed area.

2. Require occupiers and owners of land in the proclaimed area to give access to such land at all times to an Inspector with or without assistants for the purpose of inspection and/or placing on such properties any lures or traps and/or applying on such properties any spray material or bait and/or performing such other acts which in the opinion of an Inspector are necessary for the prevention of the introduction or spread of fruit fly.

Schedule

Portions of Victoria declared by this Proclamation to be a Proclaimed Area.

The Cities of Altona, Berwick, Box Hill, Brighton, Broadmeadows, Brunswick, Camberwell, Caulfield, Chelsea, Coburg, Collingwood, Croydon, Dandenong, Doncaster and

Templestowe, Essendon, Fitzroy, Footscray, Frankston, Hawthorn, Heidelberg, Kew, Knox, Malvern, Melbourne, Moorabbin, Mordialloc, Northcote, Nunawading, Oakleigh, Port Melbourne, Prahran, Preston, Richmond, Ringwood, Sandringham, South Melbourne, Springvale, St. Kilda, Sunshine, Waverley and Williamstown.

The Shires of Bulla, Diamond Valley, Eltham, Melton, Werribee and Whittlesea.

The Cities of Mildura, Swan Hill, Echuca, Bendigo, Shepparton, Benalla, Wangaratta, Sale and Traralgon.

The Shires of Mildura, Swan Hill, Kerang, Cohuna, Gordon, Rochester, Huntly, Deakin, Nathalia, Rodney, Shepparton, Numurkah, Cobram, Tungamah, Yarrawonga, Wangaratta, Benalla, Rutherglen, Chiltern, Beechworth, Yackandandah, Towong, Upper Murray, Oxley, Myrtleford, Bright, Avon, Maffra, Bairnsdale, Rosedale, Alberton and Traralgon.

The Towns of Bairnsdale and Kyabram.

The Boroughs of Kerang and Eaglehawk.

Given under my Hand and the Seal of the State of Victoria aforesaid, at Melbourne, this twenty-third day of August, in the year of Our Lord One thousand nine hundred and eighty-three, and in the thirty-second year of the reign of Her Majesty Queen Elizabeth the Second, Queen of Australia.

(L.S.) BRIAN MURRAY

By His Excellency's Command

D. E. KENT

Minister of Agriculture

GOD SAVE THE QUEEN!

Vegetation and Vine Diseases Act 1958
DECLARING A PROCLAIMED AREA

PROCLAMATION

By His Excellency the Governor of the State of Victoria and its Dependencies in the Commonwealth of Australia, &c., &c. &c.

Whereas by section 25 of the *Vegetation and Vine Diseases Act 1958*, it is provided that where the Governor in Council is of the opinion that it is necessary to protect the fruit industry of Victoria against the introduction or spread of insects of the family Trypetidae (commonly known as fruit flies), he may by Proclamation declare any portion of Victoria specified therein to be a proclaimed area and prohibit subject to regulations the removal from any place in the proclaimed area to any place outside that area or from any place in the proclaimed area to any other place in that area of any fruit fly or any fruit or vegetables of a kind or species which in his opinion may provide a host for fruit fly and require occupiers and owners of land in the proclaimed area to take such action for the prevention of the introduction or spread of fruit fly as is specified in the Proclamation:

Now therefore I, the Governor of the State of Victoria in the Commonwealth of Australia, being of the opinion that it is necessary to protect the fruit industry against the introduction or spread of insects of the family Trypetidae (commonly known as fruit flies) and by and with the advice of the Executive Council of the said State, do by this my Proclamation hereby —

1. Declare those portions of Victoria described in the First Schedule to this Proclamation to be a proclaimed area.

2. Require occupiers and owners of land in the proclaimed area to give access to such land at all times to an Inspector with

or without assistants for the purpose of inspection and/or placing on such properties any lures or traps and/or applying on such properties any spray material or bait and/or performing such other acts which in the opinion of an Inspector are necessary for the prevention of the introduction or spread of fruit fly.

3. Prohibit subject to regulations the removal from any place within the proclaimed area to any place outside that area or to any other place in that area of any fruit fly or any fruit or vegetables of a kind or species grown within the proclaimed area and named in the Second Schedule to this Proclamation unless such removal is made on the instruction of an Inspector or with his written permission, provided that fruit or vegetables passing through the proclaimed area may leave the proclaimed area without such instruction if the vehicle carrying such fruit or vegetables does not come to a halt within the proclaimed area except as required by traffic regulations.

First Schedule

Portions of Victoria declared by this Proclamation to be a Proclaimed Area.

1. The Rural City of Wodonga
2. The Shires of Omeo, Tambo and Orbost

Second Schedule

Fruits and Vegetables which in the opinion of the Governor in Council may provide a host for fruit fly —

| | |
|----------------------|---------------|
| Apples | Loquats |
| Apricots | Nectarines |
| Avocadoes | Passion Fruit |
| Banana Passion Fruit | Peaches |
| Cactus | Pears |
| Capsicums | Peppers |
| Chillies | Persimmons |
| Chinese Gooseberries | Plums |
| Citrus Fruits | Pomegranates |
| Egg Fruit | Quinces |
| Feijoas | Tomatoes |
| Figs | Tree Tomatoes |
| Guavas | |

Given under my Hand and the Seal of the State of Victoria aforesaid, at Melbourne, this twenty-third day of August, in the year of Our Lord One thousand nine hundred and eighty-three, and in the thirty-second year of the reign of Her Majesty Queen Elizabeth the Second, Queen of Australia.

(L.S.) BRIAN MURRAY

By His Excellency's Command

D. E. KENT

Minister of Agriculture

GOD SAVE THE QUEEN!

Liquor Control Act 1983

SUSPENSION OF THE OPERATION OF SECTIONS 11 A AND 104 (6) OF THE LIQUOR CONTROL ACT 1968

PROCLAMATION

By His Excellency the Governor of the State of Victoria and its Dependencies in the Commonwealth of Australia, &c., &c. &c.

Whereas section 8 of the *Liquor Control Act 1983* provides that the operation of sections 11 A and 104 (6) of the *Liquor Control Act 1968* may be suspended by Proclamation of the Governor in Council published in the *Government Gazette*:

Now therefore I, the Governor of the State of Victoria in the Commonwealth of Australia, by and with the advice of the

Executive Council of the said State, and in pursuance of the powers conferred by section 8 of the *Liquor Control Act 1983* do by this my Proclamation suspend the operation of sections 11 A and 104 (6) of the *Liquor Control Act 1968* from 24 August 1983.

Given under my Hand and the Seal of the State of Victoria aforesaid, at Melbourne, this twenty-third day of August, in the year of Our Lord One thousand nine hundred and eighty-three, and in the thirty-second year of the reign of Her Majesty Elizabeth the Second, Queen of Australia.

(L.S.) BRIAN MURRAY

By His Excellency's Command

IAN CATHIE
Minister for Economic Development
GOD SAVE THE QUEEN!

Liquor Control Act 1983, No. 9931

DATE OF COMING INTO OPERATION OF SECTION 8

PROCLAMATION

By His Excellency the Governor of the State of Victoria and its Dependencies in the Commonwealth of Australia, &c., &c., &c.

Whereas by an Act of the Parliament of the State of Victoria passed in the thirty-second year of the reign of Her Majesty Elizabeth the Second, Queen of Australia, entitled the *Liquor Control Act 1983, No. 9931*, it is amongst other things enacted that the several provisions of that Act shall come into operation on a day or the respective days to be fixed by proclamation or successive proclamations of the Governor in Council published in the *Government Gazette*:

Now therefore I, the Governor of the State of Victoria in the Commonwealth of Australia, by and with the advice of the Executive Council of the said State do by this my Proclamation fix Wednesday, 24 August 1983 as the day on which section 8 of the *Liquor Control Act 1983, No. 9931*, shall come into operation.

Given under my Hand and the Seal of the State of Victoria aforesaid, at Melbourne, this twenty-third day of August, in the year of Our Lord One thousand nine hundred and eighty-three, and in the thirty-second year of the reign of Her Majesty Elizabeth the Second, Queen of Australia.

(L.S.) BRIAN MURRAY

By His Excellency's Command

IAN CATHIE
Minister for Economic Development
GOD SAVE THE QUEEN!

Reference Areas Act 1978

MINISTRY FOR CONSERVATION
RUTH'S GULLY REFERENCE AREA

PROCLAMATION

By His Excellency the Governor of the State of Victoria and its Dependencies in the Commonwealth of Australia, &c., &c., &c.

I, the Governor of the State of Victoria, in the Commonwealth of Australia, by and with the advice of the Executive Council of the said State and in pursuance of the provisions contained in Section 3 of the *Reference Areas Act 1978* do hereby proclaim the area shown on Plan No. M-250.0041

hereunder, the original of which is lodged at the Ministry for Conservation, 240 Victoria Parade, East Melbourne, 3002, to be the Ruth's Gully Reference Area.

MINISTRY FOR CONSERVATION
REFERENCE AREAS ADVISORY COMMITTEE
RUTH'S GULLY REFERENCE AREA
File No 80-9-16 Plan No 0041

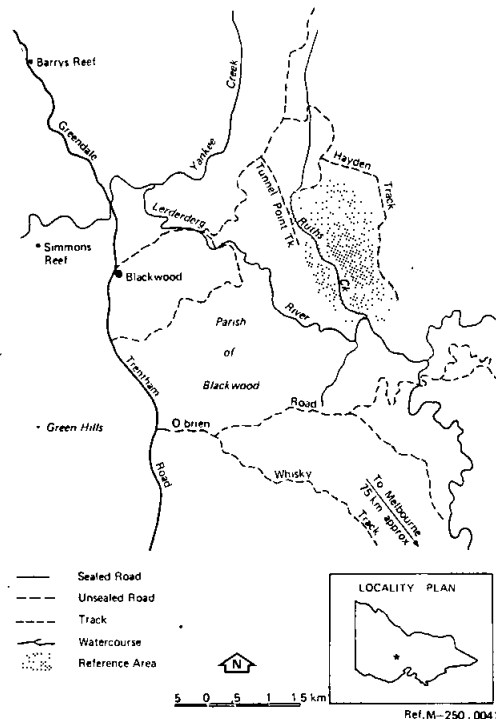

Given under my Hand and the Seal of the State of Victoria aforesaid, at Melbourne, this twenty-third day of August, in the year of Our Lord One thousand nine hundred and eighty-three, and in the thirty-second year of the reign of Her Majesty Queen Elizabeth the Second, Queen of Australia.

(L.S.) BRIAN MURRAY

By His Excellency's Command

EVAN WALKER
Minister for Conservation
GOD SAVE THE QUEEN!

Reference Areas Act 1978

MINISTRY FOR CONSERVATION
BENNIE CREEK REFERENCE AREA

PROCLAMATION

By His Excellency the Governor of the State of Victoria and its Dependencies in the Commonwealth of Australia, &c., &c., &c.

I, the Governor of the State of Victoria, in the Commonwealth of Australia, by and with the advice of the Executive Council of the said State and in pursuance of the provisions

contained in Section 3 of the *Reference Areas Act 1978*, do hereby proclaim the area shown on Plan No. M-250.0040 hereunder, the original of which is lodged at the Ministry for Conservation, 240 Victoria Parade, East Melbourne, 3002, to be the Bennie Creek Reference Area.

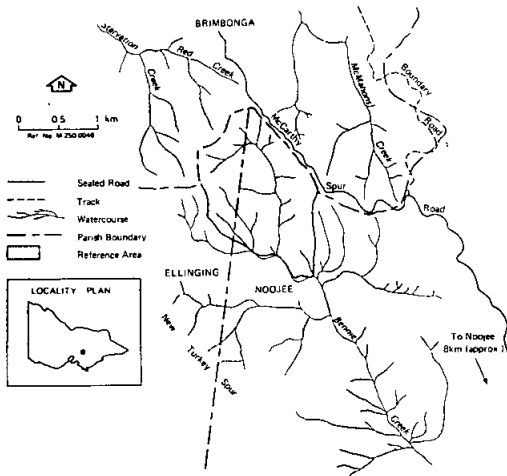
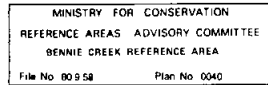

Given under my Hand and the Seal of the State of Victoria aforesaid, at Melbourne, this twenty-third day of August, in the year of Our Lord One thousand nine hundred and eighty-three, and in the thirty-second year of the reign of Her Majesty Queen Elizabeth the Second, Queen of Australia.

(L.S.)

BRIAN MURRAY

By His Excellency's Command

EVAN WALKER
Minister for Conservation

GOD SAVE THE QUEEN!

GOVERNMENT NOTICES

Fuel Prices Regulation Act 1981

ORDER FIXING AND DECLARING THE MAXIMUM PRICE OF DECLARED FUELS UNDER SECTION 7

Whereas by Notice dated 30 July 1982 and published in the *Government Gazette* on 4 August 1982 the Minister declared —

- (a) the whole of Victoria to be a proclaimed area; and
- (b) certain kinds of fuel to be declared fuels.

For the purpose of the *Fuel Prices Regulation Act 1981* with effect as from 4 August 1982:

And whereas, pursuant to Section 7 of the said Act, the Prices Commissioner may, with respect to any declared fuel, from time to time, by Order published in the *Government*

Gazette fix and declare the maximum price at which any such fuel may be sold generally or in any part of the State or in any proclaimed area.

Now therefore, I, Allan Herbert Miller Fels, Prices Commissioner, do hereby fix and declare maximum prices inclusive of existing taxes in the whole of Victoria effective from 22 August 1983.

The maximum prices set out below are applicable except that the prices may be varied by an amount equal to any future increases or decreases in taxes, imposts, customs or excise duty payable pursuant to any act, regulation or by-law of the Commonwealth of Australia (Imposts) directly applicable to the products which are the subject of this Order from the date on which such future increases or decreases become effective providing that —

- (a) any increases do not exceed the actual money amount of any future additional imposts placed upon the particular product;
- (b) the impost can be readily determined as a price adjustment in relation to a specific product and is a precise amount which does not require a calculated apportionment between the products which are the subject of this Order;
- (c) the Commissioner is notified within 24 hours of the increases or decreases in prices which have been adopted or are proposed to be adopted resulting from the imposts;
- (d) any increases or decreases put into effect are of an interim nature and subject to final consideration and confirmation by the Commissioner.

For The Free Delivery Area

Maximum Bulk Wholesale Price to Resellers:

| | |
|-----------------------|----------------------|
| Motor Spirit 97 RON | 41.2 cents per litre |
| Motor Spirit 89 RON | 40.0 cents per litre |
| Automotive Distillate | 42.0 cents per litre |

Maximum Retail Price:

| | |
|-----------------------|----------------------|
| Motor Spirit 97 RON | 45.2 cents per litre |
| Motor Spirit 89 RON | 44.0 cents per litre |
| Automotive Distillate | 46.0 cents per litre |

For Areas Outside the Free Delivery Area:

The same maximum prices as those above apply, plus an amount equivalent to the amount (if any) that, at the time the sale is made, is the freight differential approved by the Petroleum Products Pricing Authority in respect of deliveries of motor spirit or automotive distillate by the vendor to the area where the product is delivered less any subsidy payable under the *States Grants (Petroleum Products) Act 1965*.

This Order supersedes all previous Orders.

18 August 1983

A. H. M. FELS
Prices Commissioner

Prices Commissioner

I, Peter Cornelis Spyker, Minister of Consumer Affairs, hereby inform you that I do not propose to give you a direction not to publish this proposed Order under Section 7 of the *Fuel Prices Regulation Act 1981*.

18 August 1983

P. C. SPYKER
Minister of Consumer Affairs

Private Agents Act 1966

NOTICE OF RECEIPT OF APPLICATIONS FOR LICENCES UNDER THE PROVISIONS OF THE PRIVATE AGENTS ACT 1966

The Clerk(s) of the Magistrates' Court(s) as listed hereunder hereby give notice that applications, as under, have been lodged for hearing by the said Court(s) on the date(s) specified.

Any person desiring to object to any of such applications must—

- (a) lodge with the respective Clerk of the Magistrates' Court a notice in the prescribed form of his objection and of the grounds thereof;
- (b) cause a copy of such notice to be served personally or by post upon the applicant at least three days before the hearing of the application; and
- (c) send or deliver—
 - (i) where the objection is not made by the officer in charge of the police district in which the Court is situated—a copy of the notice to such officer; and
 - (ii) where the objection is not made by the Registrar or Deputy Registrar—a copy to the Registrar.

| <i>Full Name of Applicant*</i> | <i>Place of Abode of Applicant or Nominee</i> | <i>Name of Firm or Corporation</i> | <i>Address for Registration</i> | <i>Type of Licence</i> | <i>Date of Hearing</i> |
|--|---|------------------------------------|----------------------------------|-------------------------|------------------------|
| MAGISTRATES' COURT, WILLIAMSTOWN | | | | | |
| Colson, Lee | 18 Clematis Ave, North Altona | | 18 Clematis Ave, North Altona | Guard Agent | 12.9.83 |
| Dated at Williamstown 15 August 1983 J. COLLINS, Clerk of the Magistrates' Court | | | | | |
| MAGISTRATES' COURT, CHELSEA | | | | | |
| Jones, Russell Douglas | 4/32 Golden Ave, Bonbeach | | 4/32 Golden Ave, Bonbeach | Inquiry Agent | 27.9.83 |
| " " | " " | | " " | Process Server | " |
| Dated at Chelsea 15 August 1983 H. McINNES, Clerk of the Magistrates' Court | | | | | |
| MAGISTRATES' COURT, FRANKSTON | | | | | |
| Collisson, Robert Paul | 17 Gronn Pl, West Brunswick | Ronald Daryl Cole | 176 Bellbird Rd, Mt Eliza | Watchman | 2.9.83 |
| Dated at Frankston 15 August 1983 B. O'TOOLE, Clerk of the Magistrates' Court | | | | | |
| MAGISTRATES' COURT, PRAHRAN | | | | | |
| Ballinger, Laurence Thomas | 8 Dove Crt, Coolaroo | Mayne Nickless | 28 Stephenson St, Richmond | Watchman | 2.9.83 |
| Butler, John Raymond | 27 Quinn St, Prahran | " " | " " | " | " |
| Cunningham, Brian Robert | 1/20 Wheatsheaf Rd, Glenroy | " " | " " | " | " |
| Busse, Martin | 6 Jerico Pl, Rawson via Moe | " " | " " | " | " |
| Pryor, Phillip John | 70 Olivebank Rd, Ferntree Gully | RAW Cranston Investigations | 37 Albion St, Prahran | Commercial Sub-Agent | " |
| Reilly, Barry | 127 Barkers Rd, Dandenong | Mayne Nickless | 28 Stephenson St, Richmond | Watchman | " |
| Dated at Prahran 12 August 1983 V. J. ARDLIE, Clerk of the Magistrates' Court | | | | | |
| MAGISTRATES' COURT, PORT MELBOURNE | | | | | |
| Lawson, William Thomas | 378 Richardson St, Middle Park | Armaguard | 117 Dow St, Port Melbourne | Watchman | 15.9.83 |
| Dated at Port Melbourne 12 August 1983 J. VITALE, Clerk of the Magistrates' Court | | | | | |
| MAGISTRATES' COURT, SPRINGVALE | | | | | |
| Segedin, John Joseph | 1 Sara Crt, Noble Park | | 1 Sara Crt, Noble Park | Process Server | 9.9.83 |
| " " | " " | | " " | Inquiry Agent | " |
| " " | " " | | " " | Guard Agent | " |
| Dated at Springvale 12 August 1983 K. B. O'HARE, Clerk of the Magistrates' Court | | | | | |

*Or in the case of a firm or corporation, of the Nominee

PRIVATE AGENTS—continued

| Full Name of Applicant* | Place of Abode of Applicant or Nominee | Name of Firm or Corporation | Address for Registration | Type of Licence | Date of Hearing |
|--|--|-------------------------------|-------------------------------|-----------------|-----------------|
| MAGISTRATES' COURT, PRESTON | | | | | |
| Chandler, Bernard Russell | 62 O'Connor St, Reservoir | | | Inquiry Agent | 31.8.83 |
| " " | " " | | | Process Server | " |
| Dated at Preston 11 August 1983 T. WILSON, Clerk of the Magistrates' Court | | | | | |
| MAGISTRATES' COURT, OAKLEIGH | | | | | |
| Jones, Paul | 4 Foy Crt, Glen Waverley | Quebec Couriers Pty. Ltd. | Box 184, Mt Waverley | Watchman | 7.9.83 |
| Dated at Oakleigh 15 August 1983 A. G. HARGREAVES, Clerk of the Magistrates' Court | | | | | |
| MAGISTRATES' COURT, SOUTH MELBOURNE | | | | | |
| Schoch, Dale | 1/44 Shelley St, Elwood | Security Protection Pty. Ltd. | 165 Moray St, South Melbourne | Watchman | 21.9.83 |
| McLeod, Robert John | 337 Liberty Pde, West Heidelberg | " " | " " | " | " |
| Dated at South Melbourne 11 August 1983 R. J. McHUGH, Clerk of the Magistrates' Court | | | | | |

*Or in the case of a firm or corporation, of the Nominee

Stock Diseases Act 1968

In pursuance of section 32 (1) of the *Stock Diseases Act 1968*, the name and address of owners of properties, together with the name and location of properties within the footrot control area which are at present under quarantine restrictions because of footrot, are listed below.

| Name | Address | Farm Location |
|--|------------------------|-----------------------------------|
| Bramall, W. L. | "Yering", Digby | Digby Dartmoor Road |
| Cameron, J. & E. & J. | Toolondo | Toolondo |
| Collie, E. J. | Box 38, Dartmoor | Dartmoor |
| Degaris, S.A. | Wallacedale | Wallacedale |
| Kobo Investments P/L | Box 798, Portland | Portland, Lyons, Yaaheet, Kenmare |
| Lewis, D. L. & J. L. | Dunkeld Rd., Cavendish | Woolpooer |
| Loats Family Farm | RSD 208, Hamilton | Yulecart |
| Loats, N. J. A. J & R. E. & Executors of O. G. & B. A. Loats | RSD 208, Hamilton | Yulecart |
| Longbottom, C. N. | Langkoop | Langkoop |
| Nossack, R. | P.O. Box 68, Nhill | Kinamakotka |
| Patzel, I. | "Bamboa", Strathdownie | Strathdownie |
| Russell, I. M. & J. M. | "Carmona", Balmoral | Balmoral |
| Russell, J. B. & G. E. | RMB 5434, Horsham | Nurrabel |
| Tuloona Pastoral Services | Harrow | Harrow |

The following is a list of those properties within the footrot control area which have been released or recommended to be released from quarantine or restriction since March 1 1983.

| Name | Address | Farm Location |
|---------------------------|-----------------------------------|---------------------|
| Dyson, S. R., (estate of) | P.O. Dartmoor | Digby Dartmoor Road |
| Guthrie & Williams | Chetwynd | Chetwynd |
| Pettingill & Higgs | "Palpara 9B", Box 22, Mt. Gambier | Palpara |
| Tobin & Healy | 54 Valda Av, Nth. Box Hill | Tahara |

D. E. HORE
Acting Director-General of Agriculture

Soil Conservation and Land Utilization Act 1958
GELLIBRAND RIVER WATER SUPPLY CATCHMENT
 Notice of Determination of Land Use

Proclaimed in part 5 November 1969, *Victoria Government Gazette* No. 103 dated 12 November 1969, and in part 12 June 1979, *Victoria Government Gazette* No. 49 dated 20 June 1979, pursuant to Section 22 (1) of the *Soil Conservation and Land Utilization Act 1958*.

In pursuance of the provisions of Section 23, sub-section (1) of the *Soil Conservation and Land Utilization Act 1958*, the Soil Conservation Authority, after consultation with the Land Conservation Council, has determined the land use for all that land in the Parishes of Barongarook, Barramunga, Barwongemoong, La Trobe, Moomowroong, Moorbanool, Natte Murrang, Newlingrook, Olangolah, Weeaprounah, Wiridjil, Wyelangta and Yaughner within the boundaries of the Gellibrand River Water Supply Catchment delineated and marked on Plan No. 2297, or within the boundaries of the Gellibrand River (South Otway) Water Supply Catchment delineated and marked on Plan No. S-746.

The area concerned is shown on the locality plan below. All land within this area shall be used in accordance with the particular category of land use to which it has been assigned in the Land Use Determination.

The boundaries of the land use categories are shown on the ten mapsheets of Plan No. S-1297 and are intended as a guide to persons and public authorities involved in land use and management in the area, who should consult with the Soil Conservation Authority before making any changes in land use.

The text and mapsheets of the Land Use Determination may be viewed at or obtained from the offices of the Soil Conservation Authority at Kew and Colac. Landowners and relevant public authorities will be advised by letter.

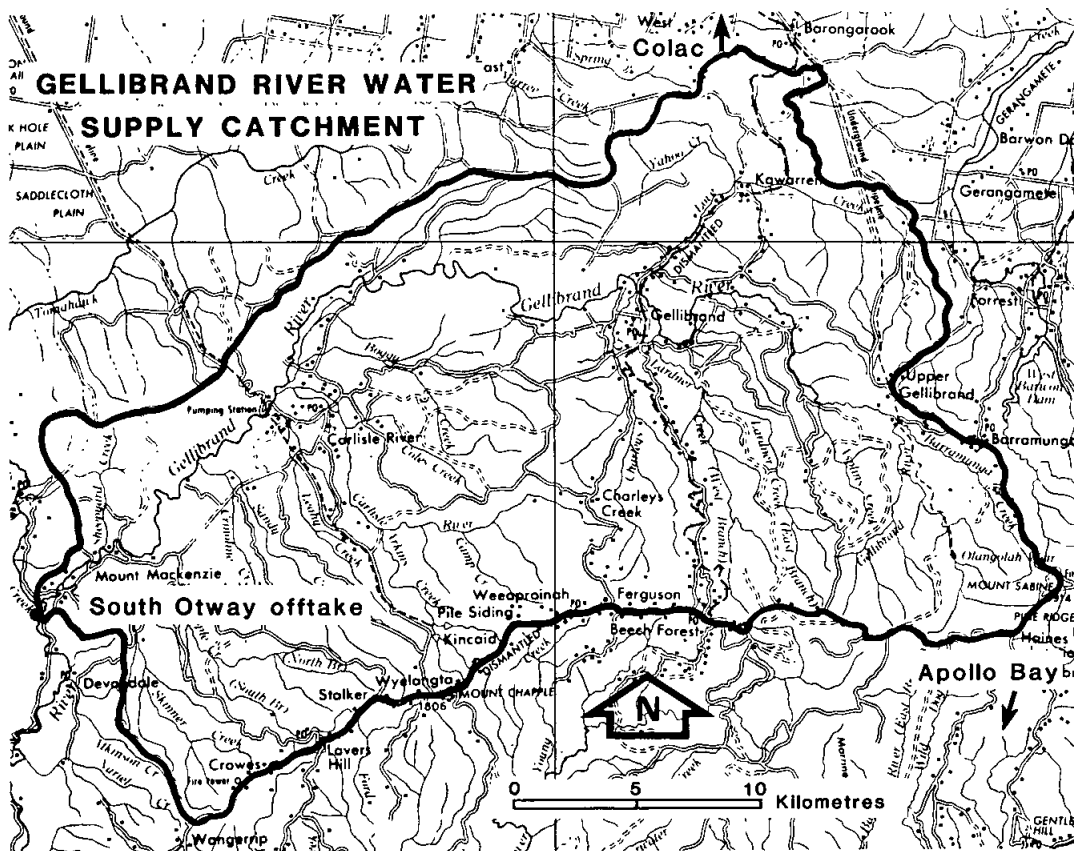

J. COUNIHAN
 Acting Secretary

MELBOURNE AND METROPOLITAN BOARD OF
WORKS
GENERAL NOTICE

The Melbourne and Metropolitan Board of Works having made provision for carrying off the sewage of each and every property which or any part of which is situate in the Sewerage Areas hereinafter described doth hereby declare that on and after 29 August 1983 each and every property so situate shall be deemed to be a seweraged property within the meaning of the *Melbourne and Metropolitan Board of Works Act 1958*.

The Sewerage Areas hereinbefore referred to are:

Sewerage Area No. 4681

City of Knox — This area comprises all lots in Bettina Place, lots 6 to 3 and that piece of land described on Plan of Consolidation No. 154386 Janine Street, that piece of land described on Certificate of Title Volume 8132 Folio 108, lots 20 and 21 Ferntree Gully Road.

Sewerage Area No. 4690

City of Knox — This area comprises lot 2 and that piece of land described on Certificate of Title Volume 9467 Folio 520 Burwood Highway.

Sewerage Area No. 4707

Shire of Whittlesea — This area comprises lot 4 Plenty Road.

Sewerage Area No. 4709

Shire of Eltham — This area comprises that piece of land described on Plan of Consolidation No. 101986 Valley Road.

Sewerage Area No. 4733

City of Chelsea — Commencing at the junction of Nepean Highway and Patterson River, thence southerly and easterly along the boundary of Sewerage Area No. 3843, southerly along Station Street, westerly along Eel Race Road, southerly along Nepean Highway, westerly along the Metropolis Boundary for sewerage purposes, northerly along Port Phillip Bay Foreshore Reserve and easterly along Patterson River to the commencing point.

Sewerage Area No. 4736

City of Moorabbin — This area comprises lots 7 and 8 Hannah Street, lot 6, that piece of land described on Plan of Consolidation No. 155025 and lot 1 Herald Street, lot 2 Warrigal Road.

Sewerage Area No. 4739

City of Sunshine — This area comprises all lots in Ada Court, Lisban Court and Anley Place, lot 4 known as the Sunshine Golf Club, lots 395 and 396 Fitzgerald Road, lots 394 to 374 and 366 Allison Street, lots 361 to 358, 351 to 348 and 341 to 338 Merrivale Avenue, lots 337 to 330 and a Reserve Stanbury Court, a Reserve abutting Ralph Street.

Sewerage Area No. 4740

City of Doncaster and Templestowe — This area comprises all lots in Regina Terrace, lots 1 to 3 Fernlea Crescent, portion of a Tree Reserve abutting Fernlea Crescent, Blackburn Road and Warrandyte Road.

Sewerage Area No. 4745

Shire of Diamond Valley — This area comprises lots part 3, part 2, part 25, 1, 2, 3 to 7, a Reserve, lots 1, 2 and a Reserve Elder Street.

Sewerage Area No. 4752

City of Sunshine — This area comprises lot 2 Western Highway.

Sewerage Area No. 4756

City of Doncaster and Templestowe — This area comprises lot 2 Fullwood Parade, lot 4 known as the Milgate Park Primary School Landscape Drive.

Sewerage Area No. 4757

Shire of Whittlesea — Commencing at the junction of Church Street and Duffy Street, thence northerly along Duffy Street, easterly along Memorial Avenue, southerly along High Street, westerly along Rufus Street, northerly along the western boundary of lot 3 High Street, westerly along Houston Street, northerly along the western boundary of Crown Allotment 2 Section 22 Church Street and westerly along Church Street to the commencing point.

Sewerage Area No. 4759

Shire of Werribee — Commencing at the junction of Aviation Road and Carinza Avenue, westerly along Carinza Avenue and the southern boundary of lot 420 Crellin Avenue, northerly along the western boundaries of lots 420 to 396 and 5 Crellin Avenue, north easterly along Princes Highway, southerly along Ascot Street, easterly along the northern boundary of lot 36 Ascot Street, southerly along the eastern boundaries of lots 36 to 30 Ascot Street, westerly along the southern boundary of lot 30 Ascot Street, northerly along Ascot Street, westerly along the southern boundaries of lot 21 Ascot Street, lots 28 and 21 Ailsa Street, south westerly along the south eastern boundaries of lots 26 and 6 Ayr Street, north westerly along the south western boundaries of lots 6 and 5 Ayr Street, south westerly along the south eastern boundaries of that piece of land described on Plan of Consolidation No. 100702, lots 32 to 27, that piece of land described on Plan of Consolidation No. 151848, lots 3, 4 and a Drainage Reserve, westerly along the southern boundary of the said Drainage Reserve and northerly along Aviation Road to the commencing point.

Sewerage Area No. 4760

City of Chelsea — This area comprises all lots in Willmott Street and Ruvina Street, lots 31 to 18 and 13 to 1 James Avenue, lots 3, 4, 31, 30, 1, that piece of land described on Certificate of Title Volume 5096 Folio 066, lots 5 to 2, 1 and 7 Station Street, lot 8 Pine Crescent, lots 1 to 5, 21, 20 to 18, 12 to 14, 15 to 17, 14, 15, 16, 17, those pieces of land described on Certificates of Titles Volume 6084 Folio 728 and Volume 6031 Folio 160, lots 2 and 1 Mill Street, lots 61 to 46, 45 to 30, 22 and 13 to 17 Mount View Street.

Sewerage Area No. 4774

City of Waverley — This area comprises all lots in Regal Court, Robe Court, Leamington Crescent, Delfin Court and Sussex Court, lot 1, a Reserve, lots 67 to 76 Shepherd Road, lots 52, 26 to 30 and 49 to 47 Wellesley Road, lots 46, 45, 40 to 37, 32 to 29 and 24 to 21 Snowden Drive, lot 1, a further lot 1 and lots 2 to 6 Gallaghers Road, lots 7 to 12, 26, 25, 28, 27, 13, 14 and 63 to 66 Cresmont Drive.

Sewerage Area No. 4780

City of Moorabbin — This area comprises all lots in Wicks Court, lots 1, 2, 17 and 18 Dowling Road, lots 19 to 23 Clarinda Road.

Sewerage Area No. 4784

City of Sunshine — This area comprises lots 480 to 463 and 554 to 544 Denton Avenue.

Sewerage Area No. 4795

City of Keilor — This area comprises lots 54 to 62 Driscolls Road.

Dated 23 August 1983

By order of the Board

H. G. FORD
Director of Administration

SHIRE OF AVON
ROAD DEVIATION ORDER

Pursuant to the provisions of Sections 522 and 526 of the *Local Government Act 1958*, the Council of the Shire of Avon hereby directs that the land in the Parish of Meerlieu indicated by hatching on the plan hereunder, which has been purchased taken or acquired by it, shall be a Public Highway on and from the date of publication of this Order in the *Government Gazette* and declares that such land shall be a Public Highway in lieu of the land indicated by cross-hatching on the said plan.

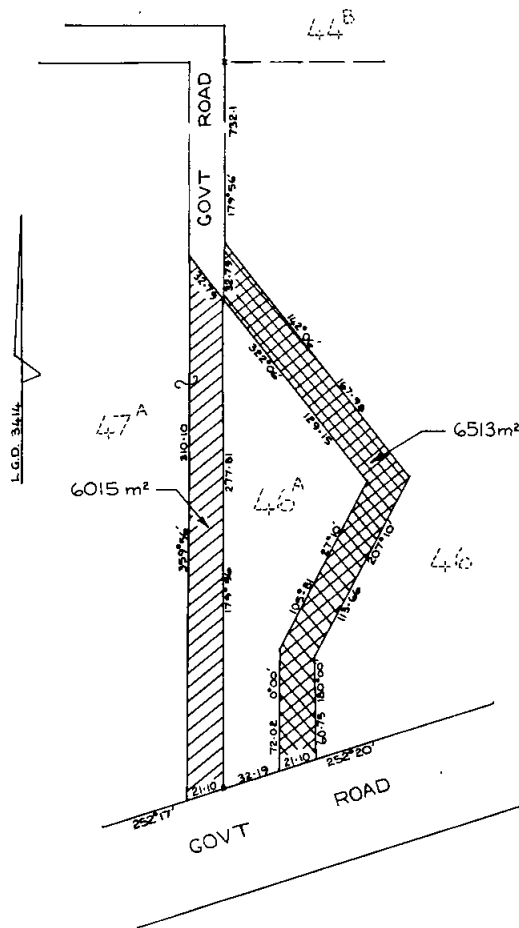

The common seal of the President, Councillors and Rate-payers of the Shire of Avon was hereunto affixed 6 June 1983

(SEAL)

S. D. STOTHERS, President
G. F. HUGHES, Councillor
G. W. BRAYSHAW, Secretary

LOCAL GOVERNMENT DEPARTMENT
ORDER CONFIRMED – SHIRE OF HASTINGS

I, Frank Noel Wilkes, Her Majesty's Minister of the Crown for the time being administering the *Local Government Act 1958*, hereby confirm the Order hereinafter referred to in pursuance of section 514 of the said Act namely:

An Order of the Council of the Shire of Hastings made on 3 May 1983 directing the compulsory taking of the land described in Certificate of Title Volume 4690 Folio 911 for the purpose of providing a place for public resort and recreation. Dated 12 August 1983

F. N. WILKES
Minister for Local Government

Local Government Department
Melbourne (83/3609)

Local Government Act 1958

NOTICE OF CONFIRMATION OF AN ORDER OF THE
COUNCIL OF THE CITY OF NORTHCOTE ADOPTING
A PROPOSAL FOR THE CLOSURE OF A STREET TO
THROUGH TRAFFIC

Pursuant to the provisions of Section 539 C of the *Local Government Act 1958*, the Governor in Council, on 16 August 1983 confirmed an order of the Council of the City of Northcote made on 22 November 1982 adopting a proposal for the closure of Fulham Road, Alphington to through traffic by the erection of a barrier at the location shown on the plan hereunder.

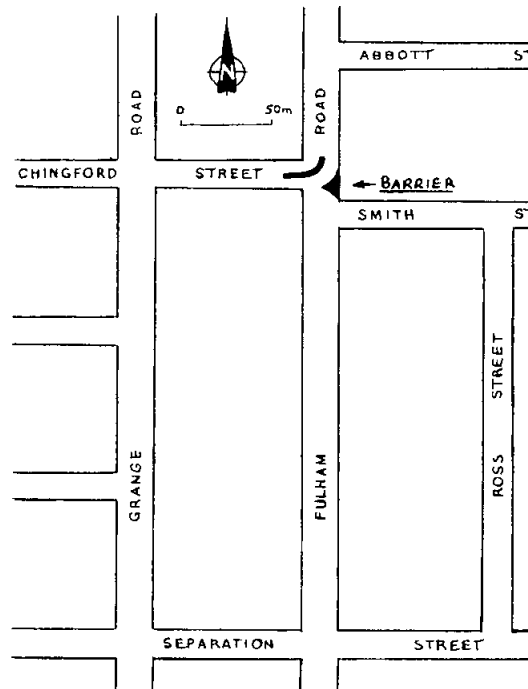

TOM FORRISTAL
Clerk of the Executive Council

Local Government Department
Melbourne (83/0376)

LOCAL GOVERNMENT DEPARTMENT
ORDER CONFIRMED — SHIRE OF HASTINGS

1. Frank Noel Wilkes, Her Majesty's Minister of the Crown for the time being administering the *Local Government Act* 1958, hereby confirm the Order hereinafter referred to in pursuance of section 514 of the said Act namely:

An Order of the Council of the Shire of Hastings made on 3 May 1983 directing the compulsory taking of the land described in Certificate of Title Volume 9307 Folio 740 for the purpose of providing a place of public resort and recreation.

Dated 12 August 1983

F. N. WILKES
Minister for Local Government

Local Government Department
Melbourne (83/3610)

Hospitals and Charities Act 1958

AUSTRALIAN GREEK SOCIETY FOR CARE OF THE
ELDERLY

Petition to Incorporate

It is notified in accordance with the provisions of Section 46 of the *Hospitals and Charities Act* 1958, that the Health Commission of Victoria has received a petition signed by twenty-five contributors to an organization known as Australian Greek Society for care of the Elderly praying that the organization be incorporated as an Institution under the provisions of the said Act.

The organization will have for its objects:

- (a) To erect a Home/s for the poor elderly.
- (b) To raise funds towards the cost of erection of a home or homes for the aged and/or disabled in Melbourne. At least fifty per cent of the initial and all additional accommodation provided by the Society is to be set aside for completely charitable cases, that is, persons of pensionable age who are in necessitous circumstances.
- (c) To purchase and acquire any real and or personal property and to construct and manage a home or homes for the aged and/or disabled and other buildings to be used for that purpose.
- (d) To act as a relief organization in providing relief to aged persons in need or in necessitous circumstances and to participate in Committee work of a philanthropic nature.
- (e) To organize domiciliary services such as home care nursing care and meals-on-wheels for elderly persons.
- (f) To organize elderly citizens clubs and to provide recreational and social opportunities for elderly persons.
- (g) To provide interpreting and communication services for elderly persons.
- (h) To provide consulting and educational information services for elderly persons and for persons wishing to plan for their old age.
- (i) To employ social workers and any other personnel that may be required to achieve these objects.
- (j) To conduct research and surveys into the problems of the aged.
- (k) To co-operate and work with other organizations with similar aims and objects.
- (l) To do all such things that are incidental to and conducive to the attainment of these objects.

If a counter petition signed by an equal or greater number of contributors is not lodged with the aforesaid Commission at 555 Collins Street, Melbourne, within one calendar month of publication of this notice, the Governor in Council may, by Order pursuant to the *Hospitals and Charities Act* 1958, declare the contributors for the time being to Australian Greek Society for Care of the Elderly to be a body corporate by the name set forth in such order.

Dated 11 August 1983

T. ROPER, Minister of Health
Health Commission of Victoria,
Melbourne

Hospitals and Charities Act 1958

WANDIN RUDOLF STEINER CURATIVE HOME

Petition to Incorporate

It is notified in accordance with the provisions of Section 46 of the *Hospitals and Charities Act* 1958, that the Health Commission of Victoria has received a petition signed by thirty contributors to an organization known as Wandin Rudolf Steiner Curative Home praying that the organization be incorporated as an Institution under the provisions of the said Act.

The organization will have for its objects:

- (a) To continuously carry on and maintain at the property and elsewhere in Victoria a residential community and occupation for life for intellectually handicapped persons.
- (b) To adhere to and foster at all times the anthroposophical philosophy and principles of the late Dr. Rudolf Steiner in their application to the welfare, education and training of people in need of special care and to provide and undertake at the property and elsewhere in Victoria amenities, facilities, benefits and services for such people.
- (c) To establish and implement curricula of curative education and vocational training for residents of the Home and other intellectually handicapped persons and to educate and train each such resident or person to the highest standard possible having regard to his or her mental capabilities and condition in life and to this end the Committee referred to in the By-Laws, shall employ as the Superintendent referred to in the By-Laws, a person who has been trained in the curative education methods enunciated by the late Dr. Rudolf Steiner in respect of people in need of special care.
- (d) To conduct, carry out or arrange vocational training and guidance of residents of the Home and provide or arrange farming, art, craft and other suitable activities or occupations for those residents whereby they may be enabled to become self-supporting or partly self-supporting members of the community at large.
- (e) To undertake and ensure the full-time care and well being of residents and to provide a physical, social and cultural community environment consistent with the philosophy and principles of the late Dr. Rudolf Steiner as will enable each such resident to contribute to his or her own individual development and fulfilment to the fullest extent possible.
- (f) To conduct, support or contribute to social, scientific or educational research into the problems of intellectually handicapped persons.

- (g) To encourage the general public to aid and assist in the cause of the intellectually handicapped and to foster and arouse a greater awareness and understanding of the individualities and needs of intellectually handicapped persons.

If a counter petition signed by an equal or greater number of contributors is not lodged with the aforesaid Commission at 555 Collins Street, Melbourne, within one calendar month of publication of this notice, the Governor in Council may, by Order pursuant to the *Hospitals and Charities Act 1958*, declare the contributors for the time being to Wandin Rudolf Steiner Curative Home to be a body corporate by the name set forth in such order.

Dated 11 August 1983

T. ROPER, Minister of Health
Health Commission of Victoria,
Melbourne

Community Welfare Services Act 1970

DECLARATION OF SEVERAL ESTABLISHMENTS AS APPROVED CHILDREN'S HOMES

In pursuance of the powers conferred by Section 29 (1) (b) of the *Community Welfare Services Act 1970*, I do hereby declare the residential units operated by Mercy Family Care Centre at:

- Helen Street, North Geelong (North Unit)
- Helen Street, North Geelong (South Unit)
- 33 Upper Skene Street, Newtown
- 40 Larcombe Street, Highton
- 76 Ruhamah Avenue, Bell Post Hill
- 13 Mernda Parade, Belmont

as approved children's homes for the purposes of the said act.
16 August 1983

PAULINE TONER
Minister

Community Welfare Services Act 1970

DECLARATION OF SEVERAL ESTABLISHMENTS AS APPROVED CHILDREN'S HOMES

In pursuance of the powers conferred by Section 29 (1) (b) of the *Community Welfare Services Act 1970*, I do hereby declare the residential units operated by Glastonbury Children's Home at:

- 4 Colac Road, Belmont
- 72 Tulloh Street, Elliminyt
- 2 Buckland Court, Elliminyt
- 22 The Avenue, Belmont
- 80 Settlement Road, Belmont
- 18 Portsmouth Crescent, Grovedale
- 20 Oberon Drive, Belmont
- 1 Nantes Street, Newtown
- 25 Carnarvon Drive, Grovedale
- 7 Bundoora Crescent, Highton
- 81 Apex Avenue, Belmont

as approved children's homes for the purposes of the said act.
16 August 1983

PAULINE TONER
Minister

Community Welfare Services Act 1970

DECLARATION OF SEVERAL ESTABLISHMENTS AS APPROVED CHILDREN'S HOMES

In pursuance of the powers conferred by Section 29 (1) (b) of the *Community Welfare Services Act 1970*, I do hereby declare the residential units operated by St. Joseph's child care agency at:

- 10 Madeline Street, Burwood
- 27 Epsom Road, Kensington
- 4 Kent Road, Surrey Hills
- 9 Finsbury Street, Flemington
- 13 Finsbury Street, Flemington
- 190 Mount Alexander Road, Flemington

as approved children's homes for the purposes of the said act.
16 August 1983

PAULINE TONER
Minister

Community Welfare Services Act 1970

DECLARATION OF INSTITUTIONS AS APPROVED CHILDREN'S HOMES

In pursuance of the powers conferred by Section 29 (1) (b) of the *Community Welfare Services Act 1970*, I do hereby declare the residential units operated by The Gordon Homes for Boys and Girls at:

- 2 Hillingdon Court, Dingley
- 7 Kingswood Drive, Dingley

as approved children's homes for the purposes of the said act.
16 August 1983

PAULINE TONER
Minister

PROHIBITION OF ENTRY INTO SAFETY ZONE — MACKEREL — 1 SUBSEA WELL

I, David Ronald White, Minister for Minerals and Energy for the State of Victoria, the Designated Authority in respect of the area specified as being adjacent to the State of Victoria, under the provisions of Section 119 of the Act, hereby prohibit from entering into or remaining in, except with my consent in writing, the area of the safety zone described hereunder all vessels other than vessels engaged in or in connexion with petroleum exploration operations or operations for the recovery of petroleum authorised by me in the area concerned.

Description of area in Safety Zone

The area which extends to a distance of five hundred metres measured from a subsea well known as Whiting situated at or about Latitude 38 deg. 14 mins. 7 secs. south, Longitude 147 deg. 53 mins. 1 sec. east and located by means of a wellhead marker buoy described hereunder.

Description of Wellhead Marker Buoy

A yellow buoy fitted approximately three metres above the water line with a radar reflector and a solar actuated lantern having a flashing yellow light showing the letter U in Morse Code at intervals of thirty seconds. The buoy is marked "Esso-Hematite".

Dated 10 August 1983

Made under the *Petroleum (Submerged Lands) Act 1967* of the State of Victoria.

DAVID WHITE
Designated Authority

CONTRACTS ACCEPTED

STAMPS, RUBBER

SCHEDULE No. 1/63

Contract from 1 September 1983 to 31 August 1985

1983/439 — Dial-A-Stamp Pty. Ltd., 210 Lygon St, Brunswick 3057. Telephone 387 7676

Orders to be lodged with contractor. Delivery to be made within seven days. Where stamps required in less than seven days — or requirements not covered by contract — Departments must seek quotation prior to issue of order.

Stamps, Rubber, Wooden Handle and Mount or Alternative, up to 125 mm long, type up to 10 mm high

| Item No. | No. of Lines | Up to 25 mm long | Over 25 mm to 50 mm | Over 50 mm to 75 mm | Over 75 mm to 100 mm | Over 100 mm to 125 mm |
|----------|---------------------------|---------------------|------------------------|------------------------|-------------------------|--------------------------|
| | | \$ | \$ | \$ | \$ | \$ |
| 1 | One line | 0.84 | 0.90 | 1.00 | 1.16 | 1.37 |
| 2 | Two lines | 0.95 | 1.05 | 1.21 | 1.32 | 1.58 |
| 3 | Three lines | 1.05 | 1.21 | 1.42 | 1.53 | 1.79 |
| 4 | Four lines | 1.16 | 1.37 | 1.58 | 1.68 | 2.00 |
| 5 | Over four lines, per line | 0.22 | 0.28 | 0.33 | 0.48 | 0.58 |

Additional charge for rectangular, square, circular or oval stamps, requiring border line not exceeding:

| Item No. | Size | Rectangular or Square | Circular or Oval | Circular or Oval with Interchangeable Date |
|----------|---|--------------------------|------------------|--|
| | | \$ | \$ | \$ |
| 6 | 50 mm x 30 mm | 1.37 | 1.89 | 12.40 |
| 7 | 75 mm x 50 mm | 1.89 | 2.42 | 12.92 |
| 8 | 100 mm x 75 mm | 2.42 | 2.94 | 13.44 |
| 9 | 125 mm x 100 mm | 2.94 | 3.47 | 17.85 |
| 10 | Additional charge for boxes incorporated in above stamps — per box — 0.65 | | | |

Approved — R. A. JOLLY — Treasurer — 10.8.83

CONTRACTS ACCEPTED — (Series 1983-84)

CALCULATORS, ELECTRONIC

SCHEDULE No. 1/71

Contract from 1 August 1983 to 31 July 1984

1983/468 — Datakey Aust. Pty. Ltd., cnr. Johnston and Brunswick Sts, Fitzroy 3065. Telephone 419 5322

1983/450 — Specialty Enterprises Pty. Ltd., 1st Floor, 305 Latrobe St, Melbourne 3000. Telephone 67 8811

| Item No. | Description of Articles | Rate | Name of Contractor |
|----------|---|-------|---------------------------------|
| | | \$ | |
| 1 | Portable — Liquid Crystal Display, 8 digits, floating decimal point, clear display, batteries included, "Sharp EL230" | 5.30 | Datakey Aust. Pty. Ltd. |
| 2 | Desk Top — Liquid Crystal Display, 10 digits, one full memory, floating and decimal point selection, "Casio JL130" | 19.35 | Specialty Enterprises Pty. Ltd. |
| 3 | Printing with Visual Display — 240 Volt AC — 12 digits, percentage, constant, decimal point selection, one full memory, "Sharp CS2189" | 69.00 | Datakey Aust. Pty. Ltd. |

Approved — R. A. JOLLY, Treasurer — 10.8.83

Industrial Relations Act 1979

SECTION 17 (1)

Notice is hereby given that in accordance with the provisions of section 17 (1) of the *Industrial Relations Act 1979* and pursuant to representations made to him by a body of persons appearing to have a bona fide interest, the Acting Minister of Labour and Industry, The Honourable S. M. Crabb, M.P. has referred the awards listed in the following schedule to the Industrial Relations Commission for its consideration having regard to claims which have been or may be lodged in respect of such awards seeking a flow-on of the effect of the impending decision of the Australian Conciliation and Arbitration Commission in the National Wage Case 1983.

Schedule

Actors Television Programmes and Feature Film; Adult Units (Day Training Centres) Instructors; Aerated Water Trade; Agricultural and Pastoral Workers; Agricultural Implements; Ambulance Services; Ambulance Superintendents and Senior Administrative Officers; Animal Manure; Asbestos Cement Workers; Bedstead and Ovenmakers; Biscuit; Boarding School Employees; Boilermakers; Boot; Boot Repairers; Bread Carters; Bread Trade; Bricklayers; Brick Trade; Builder's Labourers; Building Contracts Salesmen; Building Sheets (Compressed Straw); Bulk Grain Workers; Business Equipment (Technical Services); Butchers; Butter Factories and Condenseries; Canteen Workers; Caretakers; Carpenters; Carters and Drivers; Cement; Cement Articles; Cemetery Employees; Chemists Shops; Cigar Trade; Cleaners; Clerks (Building and Housing Societies); Clerks (Credit Societies); Clothing Trades; Clothing and Footwear Shops; Commercial Artists; Commercial Clerks; Commercial Travellers; Confectioners; Cork Trade; Country Fire Authority Officers; Country Fire-Fighters; Country Printers; Dairy Farm Workers; Day Child Care Workers; Dental Technicians; Dockmens; Draughtsmen; Dyers and Clothes Cleaners; Electrical Trade; Electrical, Furniture and Hardware Shops; Electroplaters; Engineers (skilled); Engineers and Brassworkers (unskilled); Engravers; Entertainment Employees (performers); Excavation or Roadwork; Factory-Engine-Drivers; Farriers; Fibrous Plasterers; Filemakers; Fire Brick and Refractories; Fire Brigade's Operational Staff; Fire Brigade's Service Staff; Fish; Flock; Floor Coverings (printed felt base); Food Shops; Frozen Goods; Fruit Growers; Fruit Packing; Furnishing Trades; Garden Employees; Gas Meter; General; General Shops; Glue and Gelatine; Graphic Arts; Grocers Sundries; Hairdressers and Beauty Industry; Health and Sports (Centre) Employees; Horsehair; Hospital Administrative Officers; Hospital and Benevolent Homes; Hospital Dental Officers; Hospital Managers; Hospital Medical Ancillary Services; Hospital Pharmacists; Hospital Resident Medical Officers; Hospital Scientists; Hospital Senior Medical Officers; Hotel, Restaurant and Boarding Houses; Ice; Ice Cream; Industrial Gases; Iron and Steel Rolling; Ironmoulders; Jam Trade; Jewellers; Journalists; Kindergarten and Play Centre Assistants; Kindergarten Teachers; Knitting Trade; Laundry Workers; Law Clerks; Lift; Limeburners; Mannequins and Models; Manufacturing Chemists; Marine Stores; Meat Preservers and Vegetable Oil Processors; Metalliferous Mining; Mineral Earths; Mineral Prospecting and Exploration; Mining Engine-Drivers; Mothercraft Nurses; Motor Drivers; Motor Requisites; Musicians; Nailmakers; Newsvendors; Nickel Ware; Non-Ferrous Metals; Nurserymen; Off-Course Totalizer Employees; Optical Workers; Paint and Colour; Painters; Pastrycooks; Pest Control; Photographers; Photographic Goods; Plasterers; Plaster of Paris; Plastic Moulding; Plumbers; Port Emergency Service; Port Security Officers; Pottery; Poultry; Poultry Farm Workers; Pre-mixed Concrete; Pre-school Play Leaders; Process Engravers; Production Plan-

ning; Professional Engineers; Quarry; Rabbit Processing; Racecallers; Racehorse Trainers Employees; Radio; Real Estate Salesmen; Registered Nurses; Residential Child Care Workers; Retail Dairy; Road Patrolmen's; Rod Rolling (B.H.P.); Roofing Tiles; Rubber Trade; Saddlery, Leather and Canvas Workers; Saltworkers; Sand Pit; Sausage Casings; Scientific and Technical Workers; Seamens; Security Employees; Sewage Distribution; Sewer Builders; Shearing Industry; Slaters and Tilers; Slaughtering for Export; Social and Community Services; Softgoods — Wholesale; Sports Ground Maintenance; Stonecutters; Storemen, Packers and Sorters; Sugar Refiners; Synthetic Filament Yarn; Tanners; Tanners (Furred Skins); Tar and Bitumen; Teachers' (Catholic Schools); Teachers' (Day Training Centres); Teachers' (Girls Schools); Teachers' (Independent Schools); Tea Packing; Television Performers and Session Singers; Tennis Strings; Tilelayers; Tinsmiths; Totalizer Employees; Tow Truck Drivers; Underground Clay Mining; Undertakers; Universities General Staff; Vegetable Growers; Vehicle Building Industry; Veterinary Assistants and Animal Attendants; Watch Cases; Watchmakers; Waterfront Watchmen's; Wharfs and Jetties; Wholesale Grocers; Wholesale Wine and Spirit Stores; Wire Fence and Tubular Gate; Wire Workers; Wireworking (Australian Wire Industries Pty. Ltd.); Woodworkers; Woollen and Cotton Trade.

Notice is also given that this matter is listed for mention (programming and procedure) before the Industrial Relations Commission of Victoria in Full Session at 2.15 p.m. on Monday 29 August 1983 at the hearing room situated on the 5th Floor, Nubrik House, 271 William Street, Melbourne.

A. S. DOWLING, Deputy Registrar
Industrial Relations Commission of Victoria

Industrial Relations Act 1979

INDUSTRIAL RELATIONS COMMISSION OF VICTORIA

AWARD OF THE REGISTERED NURSES
CONCILIATION AND ARBITRATION BOARD (No. 2 of 1983)

Notice is hereby given that an appeal to the Industrial Relations Commission of Victoria has been lodged against the Award (No. 2 of 1983) made on 27 July 1983 by the Registered Nurses Conciliation and Arbitration Board.

The appeal is against the operative date of the variation made to clause 8 of Part I of the Award in so far as it effects the private sector.

Section 16 (3) of the *Industrial Relations Act 1979* provides that when an appeal is brought under this section the award or part of the award appealed against shall be deemed not to have come into operation until the appeal has been dealt with by the Commission.

A. S. DOWLING, Deputy Registrar
Industrial Relations Commission of Victoria

*State Rivers and Water Supply Commission*DESIGNATION OF 1% PROBABILITY FLOOD LEVELS
— SALE

Pursuant to Section 37A of the *Drainage of Land Act 1975*, the State Rivers and Water Supply Commission, as the Drainage Authority, hereby designates the flood levels as more particularly described on Plan No. 141797 (Sheets 1-5) lodged in the Property and Legal Services Branch of the State Rivers and Water Supply Commission office at 590 Orrong Road, Armadale, at its office at Pearson Street, Maffra, Shire of Rosedale

offices at Cansick Street, Rosedale, City of Sale offices, Macalister Street, Sale and at the Shire of Maffra located in Johnson Street, Maffra.

Subject to the provisions of Section 37A (4) of the *Drainage of Land Act 1975*, any person who feels aggrieved by the designation of flood levels may within one month of the publication in the *Gippsland Times* of 26 August 1983 appeal to the Minister of Water Supply setting out the grounds of appeal against that designation.

Dated 16 August 1983

R. BIRD, Secretary

ACT 391 — SECOND SCHEDULE

A statement of trusts having been submitted by the head or authorized representative of the denomination known as The Anglican Church of Australia in the Diocese of Bendigo in Victoria, pursuant to the provisions of the Act to provide for the abolition of State Aid to Religion, for allowance of His Excellency the Governor (the same was allowed by him on 16 August 1983) and the following is the form in which such statement of trusts has been allowed

Statement of Trusts

Description of Land: Site for Church of England purposes, temporarily reserved by Order in Council of 30 January 1865, 4034 square metres, Township of Trentham, Parish of Trentham, County of Dalhousie, being Crown allotment 2, section 2A.

Commencing at a point bearing 90° 35' 10.66 metres from the north-eastern angle of Crown allotment 1, section 2A; bounded thence by Albert Street bearing 90° 35' 47.88 metres; by a line bearing 180° 35' 84.49 metres; by High Street bearing 268° 51' 20.72 metres and 275° 09' 27.16 metres; and thence by a line bearing 0° 35' 82.88 metres to the point of commencement.

Name of Trustee: Church of England Trusts Corporation for the Diocese of Bendigo, 32 Forest Street, Bendigo.

Powers of Disposition: To let, lease, sell, mortgage or exchange the said land or any portion thereof.

Purpose to which Proceeds of Disposition are to be applied: Monies obtained from sales, leases, mortgages or exchanges to be paid to the Church of England Trusts Corporation for the Diocese of Bendigo

As witness, the hand of the Governor of the State of Victoria, 16 August, 1983.

BRIAN MURRAY
Governor of the State of Victoria

ACT 391 — SECOND SCHEDULE

A statement of trusts having been submitted by the head or authorized representative of the denomination known as The Anglican Church of Australia in the Diocese of Bendigo in Victoria, pursuant to the provisions of the Act to provide for the abolition of State Aid to Religion, for allowance of His Excellency the Governor (the same was allowed by him on 16 August 1983) and the following is the form in which such statement of trusts has been allowed

Statement of Trusts

Description of Land: Site for Church of England purposes permanently reserved by Order in Council of 24 August 1874, 6073 square metres, Parish of Burke, County of Talbot, being Crown allotment 17, section 3.

Commencing at the south-western angle of Crown Allotment 18, Section 3; bounded thence by that allotment bearing 90° 00' 90.83 metres; by Crown allotment 16 bearing 180° 00'

42.65 metres; by lines bearing 270° 00' 58.24 metres and 180° 00' 38.02 metres; and thence by roads bearing 270° 00' 56.43 metres and 16° 29' 84.09 metres to the point of commencement.

Name of Trustee: Church of England Trusts Corporation for the Diocese of Bendigo, 32 Forest Street, Bendigo.

Powers of Disposition: To let, lease, sell, mortgage or exchange the said land or any portion thereof.

Purposes to which Proceeds of Disposition are to be applied: Monies obtained from sales, leases, mortgages or exchanges to be paid to the Church of England Trusts Corporation for the Diocese of Bendigo.

As witness, the hand of the Governor of the State of Victoria, 16 August 1983.

BRIAN MURRAY
Governor of the State of Victoria

PUBLIC TRUSTEE ACT 1958, SECTION 17

I hereby give notice that on 13 May 1983, the Public Trustee filed an Election to Administer the following deceased person's estate in accordance with Section 17 of the *Public Trustee Act 1958*:

Setti, Lina, late of Western General Hospital, Footscray, pensioner, died 26 February 1983.

I hereby give notice that on 9 August 1983, the Public Trustee filed Elections to Administer the following deceased persons' estates in accordance with Section 17 of the *Public Trustee Act 1958*:

Battersby, Dulcie Catherine, late of Flat 5, 257 Springfield Road, Nunawading, widow, died 10 June 1983.

Carter, Edith Ellen, also known as Edith Helen Carter, formerly of 14 Lewis Street, Coburg but late of Jedasa House Private Nursing Home, 218 Lower Plenty Road, Rosanna, died 23 May 1983.

Fretten, Rose Beatrice (In will called Beatrice Fretten), late of Flat 17, 261 Glenlyon Road, North Fitzroy, widow, died 14 June 1983.

Lawrence, Ronald McGuigan, late of 5 Kenleigh Grove, Windsor, farm development manager, died 11 June 1983.

Wicks, Elsie Maude, formerly of Flat 11/2 Grandview Grove, East Prahran but late of St. Lawrence Nursing Home, McMillan Street, Morwell, pensioner, died 3 June 1983.

Woolacott, Stella Melinda, formerly of 245 Glen Eira Road, North Caulfield but late of Athol Lodge, 41 Acland Street, St. Kilda, spinster, died 12 May 1983.

I hereby give notice that on 15 August 1983, the Public Trustee filed Elections to Administer the following deceased persons' estates in accordance with Section 17 of the *Public Trustee Act 1958*:

Cox, Doris Evelyn, late of 37 Crispe Street, Reservoir, home duties, died 15 May 1983.

Haagensen, Frederick George, late of Ballarat, pensioner, died 3 June 1983.

Hutton, Ivy Edna, late of 12 Millicent Street, Carrum, widow, died 10 July 1983.

Manser, Patricia Sinclair, late of 72 Erica Street, St. Albans, pensioner, died 11 June 1983.

17 August 1983

168 Exhibition Street,
Melbourne 3000

P. T. SPENCER
Public Trustee

Creditors, next of kin and others having claims against the estate of any of the under-mentioned deceased persons are required to send particulars of their claims to the Public Trustee, 168 Exhibition Street, Melbourne, Vic. 3000, the personal representative, on or before the 31 October 1983, after which date the Public Trustee may convey or distribute the assets having regard only to the claims of which the Public Trustee then has notice:

Battersby, Dulcie Catherine, late of Flat 5, 257 Springfield Road, Nunawading, widow, died 10 June 1983.

Cameron, Vera May, formerly of 26 The Avenue, East Malvern but late of Parkview Nursing Home, 81-83 Burke Road, East Malvern, widow, died 21 May 1983.

Carter, Edith Ellen, also known as Edith Helen Carter, formerly of 14 Lewis Street, Coburg but late of Jedasa House Private Nursing Home, 218 Lower Plenty Road, Rosanna, died 23 May 1983.

Cox, Doris Evelyn, late of 37 Crispie Street, Reservoir, home duties, died 15 May 1983.

Fretten, Rose Beatrice (In the will called Beatrice Fretten), late of Flat 17, 261 Glenlyon Road, North Fitzroy, widow, died 14 June 1983.

Haagensen, Frederick George, late of Ballarat, pensioner, died 3 June 1983.

Hutton, Ivy Edna, late of 12 Millicent Street, Carrum, widow, died 10 July 1983.

Lawrence, Ronald McGuigan, late of 5 Kenleigh Grove, Windsor, farm development manager, died 11 June 1983.

Manser, Patricia Sinclair, late of 72 Erica Street, St. Albans, pensioner, died 11 June 1983.

Muir, Lillian Maude, also known as Muir, Lillian Maud, late of 17 Cresswell Avenue, Niddrie, pensioner, died 29 May 1983.

Setti, Lina, late of Western General Hospital, Footscray, pensioner, died 26 February 1983.

Vajs, Milena, also known as Melena Vajs, late of 42 Wave Street, Elwood, widow, died 7 June 1983.

Webb, Donald Lyall, late of Flat 5, 110 Maltravers Road, Ivanhoe, retired, died 20 June 1983.

Wicks, Elsie Maude, formerly of Flat 11/2 Grandview Grove, East Prahran but late of St. Lawrence Nursing Home, McMillan Street, Morwell, pensioner, died 3 June 1983.

Woolacott, Stella Melinda, formerly of 245 Glen Eira Road, North Caulfield but late of Athol Lodge, 41 Acland Street, St. Kilda, spinster, died 12 May 1983.

17 August 1983

P. T. SPENCER
Public Trustee

BALLAN WATERWORKS TRUST

Increasing the limit of Bank Overdraft

His Excellency the Governor of the State of Victoria by and with the advice of the Executive Council thereof has by Order made on 16 August 1983 increased the total amount of the sums which the Ballan Waterworks Trust may owe at any one time in respect of moneys borrowed by overdraft of current account pursuant to the provisions of Section 288 of the *Water Act 1958*, fixed by the Governor in Council on 3 May 1967 at Seventy Thousand Dollars (\$70 000) to One Hundred Thousand Dollars (\$100 000).

TOM FORRISTAL
Clerk of the Executive Council

At the Executive Council Chamber,
Melbourne, 16 August 1983

Town and Country Planning Act 1961

CITY OF CROYDON PLANNING SCHEME 1961

Amendment No. 123

Notice of Approval

In pursuance of the powers conferred by the *Town and Country Planning Act 1961*, the Governor in Council on 16 August 1983, approved the abovementioned scheme in respect of the municipal district of the City of Croydon and for which the City of Croydon is the Responsible Authority.

The scheme comes into operation on the date this Notice is published in the *Government Gazette*.

The scheme includes the rezoning of land known as Nos. 10-12 Louisa Street, Croydon, from Residential Low 1200 to Special Uses 'A' to facilitate proposed housing for elderly persons in a joint project by the Council of the City of Croydon and Ministry of Housing.

A copy of the documents may be inspected free of charge, during office hours, at the office of the Department of Planning (Plan Inspection Section), 5th Floor, 235 Queen Street, Melbourne and at the office of the City of Croydon, Foch Avenue, Croydon.

JOHN LAWSON
Acting Secretary for Planning

Town and Country Planning Act 1961

SHIRE OF MAFFRA (HEYFIELD TOWNSHIP)

PLANNING SCHEME

Amendment No. 13

Notice of Approval

In pursuance of the powers conferred by the *Town and Country Planning Act 1961*, the Governor in Council on 16 August 1983, approved the abovementioned scheme in respect of the municipal district of the Heyfield Township and for which the Shire of Maffra is the Responsible Authority.

The scheme comes into operation on the date this Notice is published in the *Government Gazette*.

The scheme includes the rezoning of Part of Crown Allotment 54B, Parish of Tinamba, Heyfield from Industrial A to Residential Zone.

A copy of the documents may be inspected free of charge, during office hours, at the office of the Department of Planning (Plan Inspection Section), 5th Floor, 235 Queen Street, Melbourne, and at the office of the Shire of Maffra at Maffra.

J. B. LAWSON
Acting Secretary for Planning

Town and Country Planning Act 1961

SHIRE OF MORNINGTON PLANNING SCHEME 1959

Amendment No. 142, 1981

Notice of Approval

In pursuance of the powers conferred by the *Town and Country Planning Act 1961*, the Governor in Council on 16 August 1983, approved the abovementioned scheme in respect of the municipal district of the Shire of Mornington and for which the Shire of Mornington is the Responsible Authority.

The scheme comes into operation on the date this Notice is published in the *Government Gazette*.

The scheme rezones approximately 91 hectares of land described as Lot 1, PS No. 82512 and located near the corner of Forest Drive and Hearn Road, Mount Martha to Residential Low Density 2 Zone in parts, Residential Low Density 3 Zone in parts and Stream Protection Zone in parts to facilitate subdivision of the subject land.

A copy of the documents may be inspected free of charge, during office hours, at the office of the Department of Planning (Plan Inspection Section), 5th Floor, 235 Queen Street, Melbourne and at the office of the Council of the Shire of Mornington, Shire Office, Queen Street, Mornington.

J. B. LAWSON
Acting Secretary for Planning

Town and Country Planning Act 1961

SHIRE OF MILDURA PLANNING SCHEME

Amendment No. 62, 1983

Notice of Amendment

In pursuance of the powers conferred by the *Town and Country Planning Act 1961*, the Governor in Council on 16 August 1983, amended the abovementioned scheme in respect of the municipal district of the City of Mildura and for which the Council of the City of Mildura is the Responsible Authority.

The amendment comes into operation on the date this Notice is published in the *Government Gazette*.

The amendment rezones an irregular allotment of Public Open Space land on the northern alignment of Kalimna Drive to Residential "A" zone.

A copy of the documents may be inspected free of charge, during office hours, at the office of the Department of Planning (Plan Inspection Section), 5th Floor, 235 Queen Street, Melbourne, and at the office of the Council of the City of Mildura at Mildura.

J. B. LAWSON
Acting Secretary for Planning

Town and Country Planning Act 1961

SHIRE OF MORWELL PLANNING SCHEME 1977

Amendment No. 20

Notice of Amendment

In pursuance of the powers conferred by the *Town and Country Planning Act 1961*, the Governor in Council on 23 August 1983, amended the abovementioned Scheme in respect of the municipal district of the Shire of Morwell and for which the Council of the Shire of Morwell is the Responsible Authority.

The amendment comes into operation on the date this Notice is published in the *Government Gazette*.

The amendment provides for the extension from 25 months to 26 months of the period by which Residential Development Stage Number 2 must be completed.

A copy of the documents may be inspected free of charge, during office hours, at the office of the Department of Planning (Plan Inspection Section), 5th Floor, 235 Queen Street, Melbourne and at the office of the Council of the Shire of Morwell, Civic Centre, Cnr Princes and Midland Highways, Morwell.

J. B. LAWSON
Acting Secretary for Planning

Town and Country Planning Act 1961

SHIRE OF MANSFIELD PLANNING SCHEME

Interim Development Order

Amendment No. 8

Notice of Amendment

In pursuance of the powers conferred by the *Town and Country Planning Act 1961*, the Governor in Council on 23 August 1983, amended the abovementioned Order in respect

of the Shire of Mansfield and for which the Council of the Shire of Mansfield is the Responsible Authority.

The amendment comes into operation on the date this Notice is published in the *Government Gazette*.

The amendment inserts provisions relating to an Alpine Approach Study Zone, rezones certain land, generally between Mansfield and Merimbah and deletes certain provisions relating to determination of zone boundaries by the responsible authority

A copy of the documents may be inspected free of charge, during office hours, at the office of the Department of Planning (Plan Inspection Section), 5th Floor, 235 Queen Street, Melbourne, and at the office of the Council of the Shire of Mansfield.

J. B. LAWSON
Acting Secretary for Planning

Town and Country Planning Act 1961

CITY OF CAMBERWELL PLANNING SCHEME 1954

Amendment No. 51, 1979

Notice of Amendment

In pursuance of the powers conferred by the *Town and Country Planning Act 1961*, the Governor in Council on 16 August 1983, amended the abovementioned scheme in respect of the municipal district of the City of Camberwell and for which the Council of the City of Camberwell is the Responsible Authority.

The amendment comes into operation on the date this Notice is published in the *Government Gazette*.

The amendment reserves land known as Nos. 2-4 Lexia Street and No. 1 Highgate Grove, Ashburton to Public Purpose No. 1 — Car Park, subject to specific conditions.

A copy of the documents may be inspected free of charge, during office hours, at the office of the Department of Planning (Plan Inspection Section), 5th Floor, 235 Queen Street, Melbourne and at the office of the City of Camberwell, Civic Centre, Camberwell.

J. B. LAWSON
Acting Secretary for Planning

Town and Country Planning Act 1961

GIPPSLAND LAKES PLANNING SCHEME INTERIM DEVELOPMENT ORDER

Amendment No. 8

Notice of Amendment

In pursuance of the powers conferred by the *Town and Country Planning Act 1961*, the Governor in Council on 16 August 1983, amended the abovementioned Order for which the Minister for Planning is the Responsible Authority.

The amendment comes into operation on the date this Notice is published in the *Government Gazette*.

The amendment includes correction of minor errors, spelling mistakes, etc.

A copy of the documents may be inspected free of charge, during office hours, at the office of the Department of Planning (Plan Inspection Section), 5th Floor, 235 Queen Street, Melbourne.

JOHN LAWSON
Acting Secretary for Planning

Town and Country Planning Act 1961
CITY OF KNOX PLANNING SCHEME 1965
Amendment No. 248, 1982
Notice of Approval

In pursuance of the powers conferred by the *Town and Country Planning Act 1961*, the Governor in Council on 16 August 1983, approved the abovementioned scheme in respect of the municipal district of the City of Knox and for which the Council of the City of Knox is the Responsible Authority.

The scheme comes into operation on the date this Notice is published in the *Government Gazette*.

The scheme includes the rezoning of Lot 1 on LP 28080 on the east side of Highmoor Avenue, Bayswater from Residential 'B' to Special Uses 'E' (Car Park) and insert sub-clause (c) in Clause 7 (Table of Zones) Zone 22E — Special Uses E (Car Park) of the Ordinance as follows:

"(c) Within that part of the ZONE on the east side of Highmoor Avenue, Bayswater approximately 80 metres south of Mountain Highway being Lot 1 on LP 28080, the following provisions shall apply:

- (i) no access shall be obtained to the site from Highmoor Avenue;
- (ii) a 3 metre landscape buffer shall be provided along the western and southern property boundaries;
- (iii) the layout of the proposed car park shall be to the satisfaction of the Responsible Authority."

A copy of the documents may be inspected free of charge, during office hours, at the office of the Department of Planning (Plan Inspection Section), 5th Floor, 235 Queen Street, Melbourne, and at the office of the City of Knox, Civic Centre, 511 Burwood Highway, Knoxfield.

J. B. LAWSON
Acting Secretary for Planning

Town and Country Planning Act 1961
SHIRE OF MILDURA INTERIM DEVELOPMENT
ORDER No. 5, 1981

Amendment No. 7
Notice of Amendment

In pursuance of the powers conferred by the *Town and Country Planning Act 1961*, the Governor in Council on 16 August 1983, amended the abovementioned Order in respect of part Crown Allotment 15, Section 50, Block F, Parish of Mildura and situated on the north east side of San Mateo Avenue between 16th and 17th Streets, Mildura South, and for which the Council of the Shire of Mildura is the Responsible Authority.

The amendment comes into operation on the date this Notice is published in the *Government Gazette*.

The amendment includes the subdivision of the subject land into two allotments.

A copy of the documents may be inspected free of charge, during office hours, at the office of the Department of Planning (Plan Inspection Section), 5th Floor, 235 Queen Street, Melbourne, and at the office of the Council of the Shire of Mildura at Irymple.

J. B. LAWSON
Acting Secretary for Planning

Town and Country Planning Act 1961
ALBURY/WODONGA (VICTORIA) INTERIM
DEVELOPMENT ORDER 1980

West Wodonga

Notice of Amendment

In pursuance of the powers conferred by the *Town and Country Planning Act 1961*, the Governor in Council on 16 August 1983, amended the abovementioned Order for which the Albury/Wodonga Development Corporation is the Responsible Authority.

The amendment comes into operation on the date this Notice is published in the *Government Gazette*.

The amendment includes the provisions of a Residential 'B' Zone within the Order and the rezoning of land adjoining the eastern boundary of the Wodonga West Golf Course to Residential 'B' Zone.

A copy of the documents may be inspected free of charge, during office hours, at the office of the Department of Planning (Plan Inspection Section), 5th Floor, 235 Queen Street, Melbourne, and Astra House, Jack Hore Place, Wodonga and at the office of the Albury/Wodonga Development Corporation, Hume Highway, Wodonga.

JOHN LAWSON
Acting Secretary for Planning

Town and Country Planning Act 1961
SHIRE OF SHERBROOKE PLANNING SCHEME 1979
(URBAN AREAS)
Amendment 7, 1982
Notice of Approval

In pursuance of the powers conferred by the *Town and Country Planning Act 1961*, the Governor in Council on 16 August 1983, approved the abovementioned scheme in respect of the municipal district of the Shire of Sherbrooke and for which the Council of the Shire of Sherbrooke is the Responsible Authority.

The scheme comes into operation on the date this Notice is published in the *Government Gazette*.

The scheme rezones land fronting Monbulk Road, Belgrave between Cole Avenue and Glen Harrow Heights Road, from General Residential zone to Restricted zone to Restricted Use (1) — Art Gallery.

A copy of the documents may be inspected free of charge, during office hours, at the office of the Department of Planning (Plan Inspection Section), 5th Floor, 235 Queen Street, Melbourne and at the office of the Council of the Shire of Sherbrooke, Shire offices, Glenfern Road, Upwey.

J. B. LAWSON
Acting Secretary for Planning

CONTRACTS ACCEPTED — (Series 1983/84)
PUBLIC WORKS

Ascot Vale — Building works, Ascot Vale Primary School — \$412 792.00 — F. W. Barry-Brown Harrison (Vic.) Pty. Ltd., Mordialloc.

Auburn — Installation of fire service, Auburn Primary School — \$15 800.00 — J. R. and B. L. Kendall, Greensborough.

Boronia — Replace underground heating lines, Boronia Technical School — \$19 431.00 — Allstaff Air-conditioning Pty. Ltd., Cheltenham.

Branxholme — Internal and external repairs and painting. Branxholme Primary School — \$30 331.00 — P. P. Lyons, Colac.

Braybrook — Carpark siteworks, water and fire services. Braybrook Primary School — \$207 073.00 — S. J. Moran Constructions (Aust.) Pty. Ltd., Clayton.

Caulfield — External repairs and painting. Caulfield Primary School — \$33 000.00 — MDT Painting Service Renovation, St. Albans.

Clunes — Building works. Clunes Police Station — \$24 000.00 — A. W. Nicholson Pty. Ltd., Ballarat.

Cobram — External and internal renovations. Cobram Consolidated School — \$65 000.00 — M. and R. K. Skitt, Mooropna.

Dean's Marsh — Building work. Dean's Marsh Primary School — \$24 676.00 — G. N. and E. A. Trevelein Pty. Ltd., Colac.

Glen Waverley — Building work. Glen Waverley Electorate Office — \$12 520.00 — Elecwood Interiors Pty. Ltd., Moorabbin.

Hamilton — Upgrade S/A facilities and various works. Hamilton High School — \$492 094.00 — Fotheringham Investments Pty. Ltd., Warrnambool.

Heidelberg — Provision of covered wash down area and hoist. Heidelberg Technical School — \$16 860.00 — G. C. Bird Constructions, Moorabbin.

Horsham — Mechanical services. Horsham Public Offices — \$45 163.00 — G. K. and L. E. Strange, Ballarat East.

Janefield — Fire services. Janefield Training Centre — \$25 351.00 — Cooke and Dowsett Pty. Ltd., Tullamarine.

Melbourne — Restoration of facades — Cg works. Melbourne, 115 Spring Street (Hotel Windsor) — \$35 604.00 — Concrete Restorations, Burnley.

Melbourne — Alterations 12th floor, 456 Lonsdale Street (Titles) — \$41 640.00 — Consolidated Partition Industries, Maribyrnong.

Melbourne — Cleaning of public offices, 2 Treasury Place, 1.8.83 to 30.6.84 — \$378 137.73 — Initial Service Cleaners (Vic.) Pty. Ltd., Abbotsford.

Melton — Landscape works. Melton S.A.R.C. — \$13 535.00 — Victorian State Schools Horticultural Society, Oakleigh.

Nhill — Building works. Nhill High School — \$252 982.00 — Fivegood Builders, Horsham.

Port Melbourne — Annual furniture contract 1983/84 — \$16 508.00 — Bera Industries Pty. Ltd., Airport West.

Robinvale — Improvement of existing services. Robinvale Consolidated School — \$52 200.00 — DWR Services Pty. Ltd., Mildura.

Shepparton — P.A.B.X. telephone system installation. Shepparton Psychiatric Hospital — \$20 578.00 — Telecom Australia (Commercial Dept.), Melbourne.

Various — Supply of furniture to the P.W.D for the period 1.7.83 to 30.6.84 — at rates — Stem Tubular Industries (Vic.) Pty. Ltd., Boronia.

Warrnambool — Installation of intruder system. Warrnambool High School — \$37 930.00 — Bell Post Sentry Alarms, Bell Post Hill.

Westernport — Annual services. Westernport — \$12 312.00 — Wellcome Australia Ltd., Northcote.

Won Wron — Building work. Won Wron Reforestation Prison — \$20 664.00 A. Alford, Carrajung.

D. J. LITTLE, Director General, 18.8.83

STATE TENDER BOARD — CONTRACTS ACCEPTED
AMENDMENTS

| Schedule Number | Item Number | New Rate | Effective Date |
|--|-------------|--|----------------|
| | | \$ | |
| <i>Chemicals, etc. (Series 1983-84)</i> | | | |
| 1/03 | 1 | 1.10* | 15.8.83 |
| | 3 | 4.09* | |
| | 4 | 15.85* | |
| | 5 | 32.44* | |
| | 56 | 45.25§ | 19.8.83 |
| * Trading terms unchanged | | | |
| § Delete: Purchase (Regulation 84) | | | |
| Add: Ramsay & Treganowan Ltd | | | |
| <i>Bedding and Textiles (Series 1982-84)</i> | | | |
| 1/25 | 29 | 0.93* | 23.7.83 |
| | 30 | 0.96* | |
| | 31 | 0.96* | |
| * Trading terms unchanged | | | |
| <i>Construction Materials, Lime, etc. (Series 1982-84)</i> | | | |
| 1/27 | 1 | 0.2759* | 3.8.83 |
| * Trading terms unchanged | | | |
| <i>Iron (Galvanised) Downpipe, Ridging, Spouting, etc. (Series 1982-84)</i> | | | |
| 1/30 | 2-9 | Lysaght* Brownbuilt Industries Steel Roofing and Walling List 18.7.83 | 18.7.83 |
| * Trading terms unchanged | | | |
| <i>Motor Spirit, Fuel Oils, Lubricants, etc. (Series 1982-83)</i> | | | |
| 1/53B | 4 | 0.3900* | 1.8.83 |
| | 5 | 0.4100* | |
| | 6 | 0.4100* | |
| | 8 | 0.4031* | |
| | 9 | 0.4231* | |
| | 10 | 0.4231* | |
| | 29 | † | |
| | 30 | † | |
| | 31 | † | |
| | 32 | † | |
| * Trading terms unchanged | | | |
| † Delete: Plus \$0.0353 per litre unless diesel fuel exemption certificate number quoted | | | |
| Add: Plus \$0.0361 per litre unless diesel fuel exemption certificate number quoted | | | |
| <i>Tools — General (Series 1983-84)</i> | | | |
| 1/56 | 86 | 13.26* | 22.7.83 |
| | 222 | 6.10 | 29.7.83 |
| | 224 | 10.63 | |
| * Trading terms unchanged | | | |
| <i>Provisions — Melbourne District (Series 1983-84)</i> | | | |
| 2/01 | 72 | 3.21 | 1.8.83 |
| <i>Provisions — Cheese (Series 1983-84)</i> | | | |
| 2/04 | 3 | # | 1.7.83 |
| | 6 | # | |
| | 9 | # | |
| | 11 | # | |
| | 16 | # | |
| # Delete: Sandhurst Trading Co. Pty. Ltd. | | | |
| Add: Apply Tender Board | | | |

| Schedule Number | Item Number | New Rate | Effective Date |
|--|-------------|----------|----------------|
| \$ | | | |
| <i>Provisions — Beechworth District (Series 1983-84)</i> | | | |
| 2/08 (5) | 1 | 3.79 | 1.8.83 |
| | 2 | 1.22 | |
| | 3 | 1.87 | |
| | 4 | 4.51 | |
| | 7 | 25.89 | |
| | 8 | 163.84 | |
| | 9 | 9.61 | |
| | 10 | 34.43 | |
| | 14 | 23.56 | |
| | 15 | 27.45 | |
| | 16 | 3.52 | |
| | 17 | 2.52 | |
| | 18 | 5.29 | |
| | 19 | 17.58 | |
| | 20 | 38.58 | |
| | 24 | 1.57 | |
| | 27 | 1.06 | |
| | 29 | 0.72 | |
| | 30 | 8.42 | |
| | 31 | 13.49 | |
| | 33 | 0.59 | |
| | 34 | 3.02 | |
| | 36 | 6.69 | |
| | 38 | 9.13* | |
| | 40 | 0.57 | |
| | 41 | 0.75 | |
| | 45 | 0.59 | |
| | 46 | 1.27 | |
| | 48 | 38.66 | |
| | 50 | 1.06 | |
| | 51 | 2.04 | |
| | 52 | 2.96 | |

* Change of description

Delete: "Buffalo"
Add: "Imperial"

J. M. PAWSON, Secretary to the Tender Board

APPOINTMENTS AND RESIGNATIONS

APPOINTMENTS

His Excellency the Governor of the State of Victoria, by and with the advice of the Executive Council thereof, has by Orders made on 16 August 1983 been pleased to make the under-mentioned appointments, viz.:

Department of Crown Lands and Survey

Bailiffs of Crown Lands

James Ernest Barclay, Alan William Gardiner and Leslie Grundy
to be bailiffs of Crown Lands, pursuant to the provisions of section 30 of the *Land Act* 1958, in respect of the Crown land in the City of Melbourne deemed to be permanently reserved for a public museum, and with authority to discharge and exercise all the duties and powers of bailiffs of Crown lands.

Health Commission

Member of Poisons Advisory Committee

Allan Douglas Perry

to be a Member of the Poisons Advisory Committee pursuant to the provisions of section 5 (2) (j) of the *Poisons Act* 1962 for the period ending 13 August 1986.

Members of the Committees of Management of Hospitals

Vallancy Rosalind Rowlands, Cohuna District Hospital, 17 August, 1983 to 30 September, 1983.

Robert Fraser Campbell, Thomas McLennan Fawcett, John Christopher McLennan and James Freeman Rattray, The Clunes District Hospital, 27 August, 1983 to 30 September, 1983.

Peter Gunnar Lerstang, Latrobe Valley Hospital, 17 August, 1983 to 30 September, 1983.

Vallancy Rosalind Rowlands, Cohuna District Hospital, 1 October, 1983 to 30 September, 1986.

Robert Fraser Campbell, Thomas McLennan Fawcett, John Christopher McLennan and James Freeman Rattray, The Clunes District Hospital, 1 October, 1983 to 30 September, 1986.

Kenneth Arthur Forsyth Readwin, Essendon and District Memorial Hospital, 17 August, 1983 to 30 September, 1985.

Peter Gunnar Lerstang, Latrobe Valley Hospital, 1 October 1983 to 30 September 1986

to be members of Committees of Management of the abovementioned hospitals pursuant to the provisions of Section 63 F (1) of the *Hospitals and Charities Act* 1958 for the period of office as mentioned above.

TOM FORRISTAL

Clerk of the Executive Council

At the Executive Council Chamber,

Melbourne, 16 August 1983

Liquor Control Act 1968

APPOINTMENT OF LICENSING INSPECTORS

In accordance with the authority conferred upon me by Section 6 of the *Police Regulation Act* 1958, I, Eric Thomas Millar, Deputy Commissioner of Police, do hereby appoint under subsection (1) of Section 22 of the *Liquor Control Act* 1968, the following Officers of Police as Licensing Inspectors for the Divisions of the Police Districts as shown:

| Division Number | Police District | Rank and Name |
|-----------------|------------------|--|
| 2 | Avondale Heights | Inspector Lloyd Robert Harrington, No. 12429 (vice Chief Inspector M. Bruce, No. 10812). |
| 2 | Avondale Heights | Inspector James Terrance Gilbee, No. 14132 (from 21.8.83 to 11.9.83). |
| 4 | Cheltenham | Inspector Donald Henry Guilfoyle, No. 12937 (from 2.8.83 to 3.9.83). |
| 3 | Cheltenham | Inspector Lionel Bruce Schade, No. 12368 (from 7.8.83 to 3.9.83). |
| 4 | Malvern | Inspector Kenneth Martin Olsen, No. 12625 (from 9.8.83 to 12.9.83). |
| 3 | Melbourne | Inspector Daryl Richard Clarke, No. 14330 (from 14.8.83 to 10.9.83). |
| | | E. T. MILLAR Deputy Commissioner |
| 18.8.1983 | | |

RESIGNATIONS

His Excellency the Governor of the State of Victoria, by and with the advice of the Executive Council thereof, has by Orders made on 16 August 1983 accepted the resignations of the persons named hereunder of the office mentioned, viz:

Health Commission

Members of the Committees of Management of Hospitals

Mary Ellen Mulqueen

as Member of the Committee of Management of the Ararat and District Hospital as from 26 July 1983.

John Wallace Ball
as Member of the Committee of Management of the Box Hill
Hospital as from 2 August 1983.

John George Lemmey
as Member of the Committee of Management of the Casterton
Memorial Hospital as from 12 June 1983.

Stanley Walter Konig
as Member of the Committee of Management of the Goulburn
Valley Base Hospital as from 3 August 1983.

Neil Henry Hewson
as Member of the Committee of Management of the Heales-
ville and District Hospital as from 28 July 1983.

Charles Cecil Herbert Castle
as Member of the Committee of Management of the Robin-
vale and District Hospital as from 24 July 1983.

Francis Gordon Muir
as Member of the Committee of Management of the Robin-
vale and District Hospital as from 21 July 1983, in accordance with
the provisions of Section 63G (1) of the Hospitals and Charities
Act.

TOM FORRISTAL
Clerk of the Executive Council

At the Executive Council Chamber,
Melbourne, 16 August 1983

ORDERS IN COUNCIL

GEELONG WATERWORKS AND SEWERAGE TRUST
Consent to Borrowing \$93 700

At the Executive Council Chamber, Melbourne, the
Twenty-sixth day of July, 1983

Present:

His Excellency the Governor of Victoria
Mr Mackenzie | Mr Spyker
Mrs Toner | Mr Kent

Under the powers conferred by the Geelong Waterworks
and Sewerage Act and all other powers enabling him in that
behalf, His Excellency the Governor of the State of Victoria,
by and with the advice of the Executive Council of the said
State, hereby consents to the Geelong Waterworks and Sewer-
age Trust borrowing the sum of Ninety three thousand seven
hundred dollars (\$93,700) to meet the cost of the conversion
of Loan No. A.11.

And the Honourable David Ronald White, Her Majesty's
Minister of Water Supply for the State of Victoria, shall give
the necessary directions herein accordingly.

TOM FORRISTAL
Clerk of the Executive Council

LOCAL GOVERNMENT ACT 1958

At the Executive Council Chamber, Melbourne, the
sixteenth day of August, 1983

Present:

His Excellency the Governor of Victoria
Mr Cathie | Mr Walker
Mr Mathews

ROADS DISCONTINUED - CITY OF BRUNSWICK

Whereas it is provided in section 528 (2) of the *Local Govern-
ment Act 1958*, that where a road (whether or not a public high-
way but not being a road set out on land of the Crown) or any
part thereof is not required for public use, the Governor in
Council on the request of the council of the municipality in
which such road is situated made not less than one month after
publishing in a newspaper generally circulating in the district
and posting to the registered proprietor (if any) of the land and
the owners and occupiers (if any) of lands abutting or immedi-
ately adjacent to the road notice of intention to make such a
request may by Order published in the *Government Gazette*
direct that such road or part shall be discontinued and there-
upon such road or part shall be discontinued accordingly;

And whereas the Council of the City of Brunswick has
requested that the Governor in Council direct that part of a
road off Connolly Street, Brunswick be discontinued and not
less than one month previously has published in a newspaper
generally circulating in the district and posted to the registered
proprietor of the land in the road and to the owners and occu-
piers of lands abutting or immediately adjacent to the road
notice of intention to make such a request.

Now therefore, His Excellency the Governor of the State of
Victoria, by and with the advice of the Executive Council
thereof, hereby directs that the said part of a road which is
shown by hatching on the plan hereunder, shall be discon-
tinued and the land in the said part of the road may be sold
by the Council of the City of Brunswick by agreement.

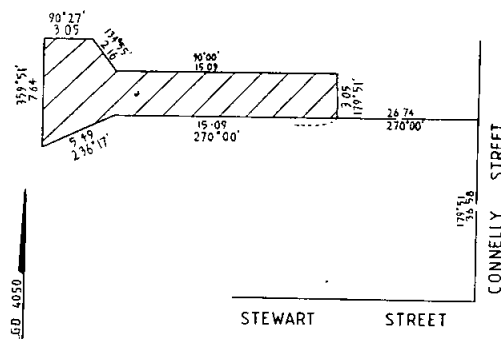

ALL LENGTHS ARE IN METRES

And the Honourable Frank Noel Wilkes, Her Majesty's
Minister for Local Government for the State of Victoria, shall
give the necessary directions herein accordingly.

TOM FORRISTAL
Clerk of the Executive Council

LOCAL GOVERNMENT ACT 1958

At the Executive Council Chamber, Melbourne, the sixteenth day of August, 1983

Present:

His Excellency the Governor of Victoria
 Mr Cathie | Mr Walker
 | Mr Mathews

ROADS DISCONTINUED – CITY OF CAULFIELD

Whereas it is provided in section 528 (2) of the *Local Government Act 1958*, that where a road (whether or not a public highway but not being a road set out on land of the Crown) or any part thereof is not required for public use, the Governor in Council on the request of the council of the municipality in which such road is situated made not less than one month after publishing in a newspaper generally circulating in the district and posting to the registered proprietor (if any) of the land and the owners and occupiers (if any) of lands abutting or immediately adjacent to the road notice of intention to make such a request may by Order published in the *Government Gazette* direct that such road or part shall be discontinued and thereupon such road or part shall be discontinued accordingly;

And whereas the Council of the City of Caulfield has requested that the Governor in Council direct that part of a road off Loch Avenue, St. Kilda East be discontinued and not less than one month previously has published in a newspaper generally circulating in the district and posted to the registered proprietor of the land in the road and to the owners and occupiers of lands abutting or immediately adjacent to the road notice of intention to make such a request.

Now therefore, His Excellency the Governor of the State of Victoria, by and with the advice of the Executive Council thereof, hereby directs:

- (a) that the said part of the road which is shown by hatching on the plan hereunder shall be discontinued;

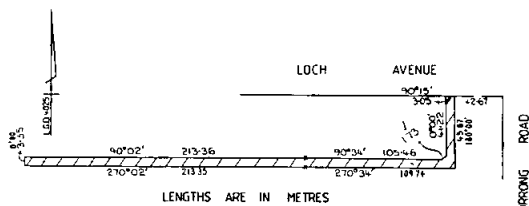

- (b) that notwithstanding such discontinuance the Melbourne and Metropolitan Board of Works shall continue to have and possess the same right title power authority or interest in or in relation to the whole of the land shown by hatching on the said plan as it had or possessed prior to such discontinuance with respect to or in connection with any drains or pipes laid or erected in on or over such land for the purposes of drainage or sewerage;

- (c) that, subject to any such right title power authority or interest the land in the said part of the road may be sold by the Council of the City of Caulfield by agreement.

And the Honourable Frank Noel Wilkes, Her Majesty's Minister for Local Government for the State of Victoria, shall give the necessary directions herein accordingly.

TOM FORRISTAL
 Clerk of the Executive Council

LOCAL GOVERNMENT ACT 1958

At the Executive Council Chamber, Melbourne, the sixteenth day of August, 1983

Present:

His Excellency the Governor of Victoria
 Mr Cathie | Mr Walker
 | Mr Mathews

ROADS DISCONTINUED – CITY OF MELBOURNE

Whereas it is provided in section 528 (2) of the *Local Government Act 1958*, that where a road (whether or not a public highway but not being a road set out on land of the Crown) or any part thereof is not required for public use, the Governor in Council on the request of the council of the municipality in which such road is situated made not less than one month after publishing in a newspaper generally circulating in the district and posting to the registered proprietor (if any) of the land and the owners and occupiers (if any) of lands abutting or immediately adjacent to the road notice of intention to make such a request may by Order published in the *Government Gazette* direct that such road or part shall be discontinued and thereupon such road or part shall be discontinued accordingly;

And whereas the Council of the City of Melbourne has requested that the Governor in Council direct that a road off Elgin Street, Carlton be discontinued and not less than one month previously has published in a newspaper generally circulating in the district and posted to the registered proprietor of the land in the road and to the owners and occupiers of lands abutting or immediately adjacent to the road notice of intention to make such a request.

Now therefore, His Excellency the Governor of the State of Victoria, by and with the advice of the Executive Council thereof, hereby directs that the said road which is shown by hatching on the plan hereunder, shall be discontinued and the land in the said road may be sold by the Council of the City of Melbourne by agreement.

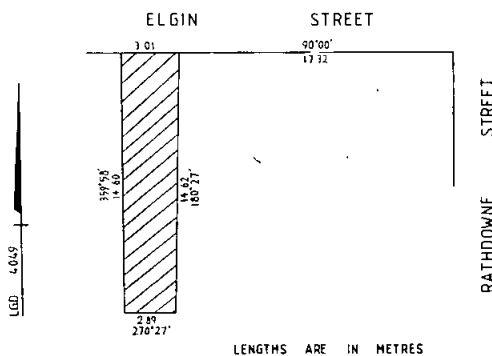

And the Honourable Frank Noel Wilkes, Her Majesty's Minister for Local Government for the State of Victoria, shall give the necessary directions herein accordingly.

TOM FORRISTAL
 Clerk of the Executive Council

LOCAL GOVERNMENT ACT 1958

At the Executive Council Chamber, Melbourne, the sixteenth day of August, 1983

Present:

His Excellency the Governor of Victoria
 Mr Cathie | Mr Walker
 Mr Mathews

ROAD DISCONTINUED – CITY OF BRUNSWICK

Whereas it is provided in section 528 (2) of the *Local Government Act 1958*, that where a road (whether or not a public highway but not being a road set out on land of the Crown) or any part thereof is not required for public use, the Governor in Council on the request of the council of the municipality in which such road is situated made not less than one month after publishing in a newspaper generally circulating in the district and posting to the registered proprietor (if any) of the land and the owners and occupiers (if any) of lands abutting or immediately adjacent to the road notice of intention to make such a request may by Order published in the *Government Gazette* direct that such road or part shall be discontinued and thereupon such road or part shall be discontinued accordingly;

And whereas the Council of the City of Brunswick has requested that the Governor in Council direct that a road off Glenlyon Road, Brunswick be discontinued and not less than one month previously has published in a newspaper generally circulating in the district and posted to the registered proprietor of the land in the road and to the owners and occupiers of lands abutting or immediately adjacent to the road notice of intention to make such a request.

Now therefore, His Excellency the Governor of the State of Victoria, by and with the advice of the Executive Council thereof, hereby directs that the said road which is shown by hatching on the plan hereunder, shall be discontinued and the land in the said road may be sold by the Council of the City of Brunswick by agreement.

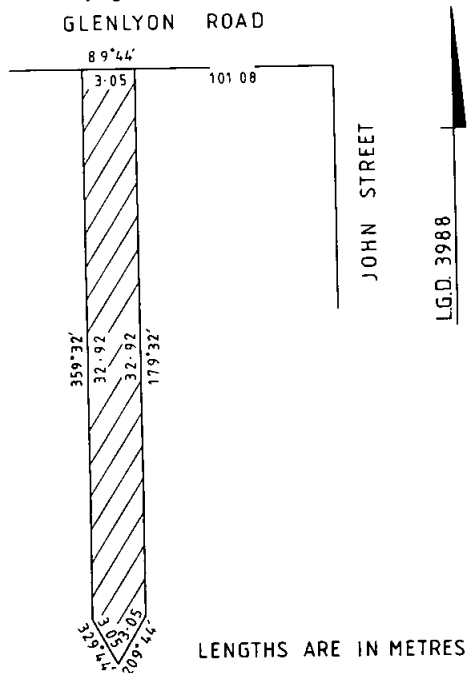

And the Honourable Frank Noel Wilkes, Her Majesty's Minister for Local Government for the State of Victoria, shall give the necessary directions herein accordingly.

TOM FORRISTAL
 Clerk of the Executive Council

LOCAL GOVERNMENT ACT 1958

At the Executive Council Chamber, Melbourne, the sixteenth day of August, 1983

Present:

His Excellency the Governor of Victoria
 Mr Cathie | Mr Walker
 Mr Mathews

CONFIRMATION OF SEPARATE RATE – CITY OF CROYDON

In pursuance of the provisions of section 287 of the *Local Government Act 1958*, His Excellency the Governor of the State of Victoria, by and with the advice of the Executive Council thereof, hereby confirms a separate rate of zero point zero nine seven seven (0.0977) cents in the dollar on the site value of the properties described in the Schedule hereunder which rate was made by the Council of the City of Croydon on 4 July, 1983 for the purpose of sealing the Devon Street carpark.

Schedule

Properties to be rated at 0.0977 cents in the dollar.

- Devon Street – No. 2.
- Hewish Road – Shop 1/3, Shops 2 & 3/3, Shop 4/3, Shop 5/3, Shop 6/3, Shop 7/3, Shop 8/3, Shop 9/3, Shop 10/3, Shop 11/3, Shop 12/3, Shop 13/3, Cinema 3, Office 1/3, Office 2/3, Nos. 2, 4, 6, 8, 10, 10A, 12, 14, 16, 18, 20, 22, 24, 26-28.
- Lacey Street – No. 1.
- Main Street – Nos. 53, 55, 57, 59, 61, 63, 65, 67-69, 71, 73, 75, 77-79, 81, 83, 85, 87, 89, 91, Office 1/87-91, Office 2/87-91, Office 3/87-91, Office 4/87-91, Office 5/87-91, Office 6/87-91, Nos. 93, 95, 97, 99, Office 1/99, Office 2/99, Office 3/99, Office 4/99, Nos. 101, 103, 105, 107, 109, 111-115, 117, 119, 121, 123, 125-129, 131-135, 137-139, 141-145, 147, 149, 151-155, 157, Office 1-3/157, Office 5-6/157, No. 159, Shop 1/161, Shop 2/161, Shop 3/161, Nos. 163, 165-169, 12, 14, 16, 18, 20, 22, 24, 26-28, 30, 32, 34, 36-38, 40, 42, Office 1/30-42, Office 2/30-42, Office 3/30-42, Office 4 and 5/30-42, Office 6/30-42, Nos. 44-46, 48, Office 1/44-48, Office 2/44-48, Office 3/44-48, Store 44-48, Nos. 50-54, Office 1st floor 50-54, Nos. 56-60, Shop 1/62-64, Nos. 66-92, 94-96, 98, 100, 100 Shop, Nos. 102, 104-112, 114, 1/114, 2/114, 116, 118, 120, 122, 126, 128, 130-132, 134-136, 150, 152, 154-156, 158, 160-162, 164, 166, Shop 1/168, Shop 2/168, Shop 3/168, Shop 4/168, Nos. 170-172, 174, 176-178, 180, rear 180, 182, 184, 186, 188, 190, 192.
- Mt. Dandenong Road – Nos. 193, 195, 197, 199, 207, 209.
- Reserve Walk – Nos. 2, 4, 6.
- The Centreway – Shops 3, 4, 5 and 6, 7, 8, 9.
- Thomas Brew Lane – Nos. 12, 14.

And the Honourable Frank Noel Wilkes, Her Majesty's Minister for Local Government for the State of Victoria, shall give the necessary directions herein accordingly.

TOM FORRISTAL
 Clerk of the Executive Council

LOCAL GOVERNMENT ACT 1958

At the Executive Council Chamber, Melbourne, the
sixteenth day of August, 1983

Present:

His Excellency the Governor of Victoria
Mr Cathie | Mr Walker
| Mr Mathews

VESTING OF A RESERVE IN THE FLINDERS SHIRE
COUNCIL

Whereas it is provided in section 569BA of the *Local Government Act 1958*, that where any map or plan has been lodged or deposited with the Registrar of Titles pursuant to section 97 of the *Transfer of Land Act 1958*, or any corresponding previous enactment (whether before or after the commencement of the *Local Government Act 1963*) and any allotment on that map or plan has been transferred the Governor in Council on the request of the council of the municipality may by Order published in the *Government Gazette* direct that the whole or any part of the land comprised in any reserve shown on that map or plan shall vest in the council whereupon such land shall so vest freed and discharged from any mortgage charge lease or sub-lease;

And whereas the Council of the Shire of Flinders has requested that a recreation reserve shown on a plan of subdivision be vested in the Council and an allotment on that plan has been transferred.

Now therefore, His Excellency the Governor of the State of Victoria, by and with the advice of the Executive Council thereof, and in pursuance of the provisions of sub-section 1 of section 569BA of the *Local Government Act 1958* doth by this Order vest in the Council of the Shire of Flinders the Recreation Reserve coloured green on Plan of Subdivision No. 13830 lodged in the Office of Titles.

And the Honourable Frank Noel Wilkes, Her Majesty's Minister for Local Government for the State of Victoria, shall give the necessary directions herein accordingly.

TOM FORRISTAL
Clerk of the Executive Council

LOCAL GOVERNMENT ACT 1958

At the Executive Council Chamber, Melbourne, the
sixteenth day of August, 1983

Present:

His Excellency the Governor of Victoria
Mr Cathie | Mr Walker
| Mr Mathews

ROADS DISCONTINUED - CITY OF DANDENONG

Whereas it is provided in section 528 (2) of the *Local Government Act 1958*, that where a road (whether or not a public highway but not being a road set out on land of the Crown) or any part thereof is not required for public use, the Governor in Council on the request of the council of the municipality in which such road is situated made not less than one month after publishing in a newspaper generally circulating in the district and posting to the registered proprietor (if any) of the land and the owners and occupiers (if any) of lands abutting or immediately adjacent to the road notice of intention to make such a request may by Order published in the *Government Gazette* direct that such road or part shall be discontinued and thereupon such road or part shall be discontinued accordingly;

And whereas the Council of the City of Dandenong has requested that the Governor in Council direct that part of a

road off Rodd Street, Dandenong be discontinued and not less than one month previously has published in a newspaper generally circulating in the district and posted to the registered proprietor of the land in the road and to the owners and occupiers of lands abutting or immediately adjacent to the road notice of intention to make such a request.

Now therefore, His Excellency the Governor of the State of Victoria, by and with the advice of the Executive Council thereof, hereby directs:

- (a) that the said part of the road which is shown by hatching, hatching marked A, cross-hatching and cross-hatching marked A on the plan hereunder shall be discontinued;
- (g) that notwithstanding such discontinuance the Dandenong Sewerage Authority shall continue to have and possess the same right title power authority or interest in or in relation to the whole of the land shown by cross-hatching and cross-hatching marked A on the said plan as it had or possessed prior to such discontinuance with respect to or in connection with any drains or pipes laid or erected in or on or over such land for the purposes of drainage or sewerage;
- (h) that, subject to any such right title power authority or interest the land in the said part of the road shown by hatching marked A and cross-hatching marked A on the said plan may be sold by the Council of the City of Dandenong by agreement and the land in the said part of the road shown by hatching and cross-hatching on the said plan shall be retained by the said Council for municipal purposes.

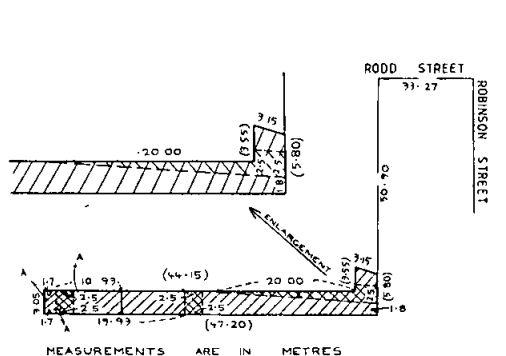

And the Honourable Frank Noel Wilkes, Her Majesty's Minister for Local Government for the State of Victoria, shall give the necessary directions herein accordingly.

TOM FORRISTAL
Clerk of the Executive Council

CROWN LAND (RESERVES) ACT 1978

At the Executive Council Chamber, Melbourne, the sixteenth day of August, 1983

Present:

His Excellency the Governor of Victoria
 Mr Cathie | Mr Walker
 | | Mr Mathews

REVOCATION OF TEMPORARY RESERVATIONS OF LANDS BY ORDERS IN COUNCIL

His Excellency the Governor of the State of Victoria, in the Commonwealth of Australia, by and with the advice of the Executive Council of the said State, pursuant to the provisions of section 10 of the *Crown Land (Reserves) Act 1978*, doth hereby revoke the temporary reservations of lands by Orders in Council hereinafter described, viz.:

CORANGAMITE — The temporary reservation by Order in Council of 18 October 1943 of 2.724 hectares of land in the Parish of Corangamite for Public purposes — (Rs.690)

DRAJURK — The temporary reservation for Road purposes and for affording access to Water and the withholding from sale, leasing and licensing by Order in Council of 13 November 1882 of 24.28 hectares of land in the Parish of Drajurk (adjoining allotment 15A) — (Rs.12483)

FOXHOW — The temporary reservation for affording access to Water and the withholding from sale, leasing and licensing by Order in Council of 24 July 1882 of 2.458 hectares of land in the Township of Foxhow, revoked as to part by Order of 18 May 1982, so far only as the portion thereof containing 1900 square metres, more or less, as defined by description and hatching on plan published in the *Government Gazette* dated 27 July 1983, is concerned — (F 27⁽²⁾) (Rs.11091)

And the Honourable Roderick Alexander Mackenzie, Her Majesty's Minister of Lands for the State of Victoria, shall give the necessary directions herein accordingly.

TOM FORRISTAL
 Clerk of the Executive Council

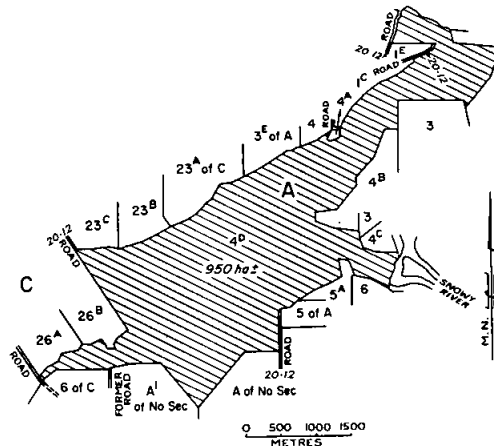

And the Honourable Roderick Alexander Mackenzie, Her Majesty's Minister of Lands for the State of Victoria, shall give the necessary directions herein accordingly.

TOM FORRISTAL
 Clerk of the Executive Council

CROWN LAND (RESERVES) ACT 1978

At the Executive Council Chamber, Melbourne, the sixteenth day of August, 1983

Present:

His Excellency the Governor of Victoria
 Mr Cathie | Mr Walker
 | | Mr Mathews

CROWN LANDS TEMPORARILY RESERVED

His Excellency the Governor of the State of Victoria, in the Commonwealth of Australia, by and with the advice of the Executive Council of the said State, pursuant to the provisions of sections 4 and 7 of the *Crown Land (Reserves) Act 1978*, and being of the opinion that the Crown lands concerned are required for the public purposes respectively mentioned, doth hereby temporarily reserve and also except from prospecting or from occupation for mining purposes under any miner's right, the Crown lands hereinafter described, viz.:

Municipal District of the City of Keilor —
DOUTTA GALLA — For Health Commission purposes — 741 square metres, being Crown allotment C1, section 18, Parish of Doutta Galla, as indicated by hatching on plan hereunder — (D 85⁽⁶⁾) (Rs.12452)

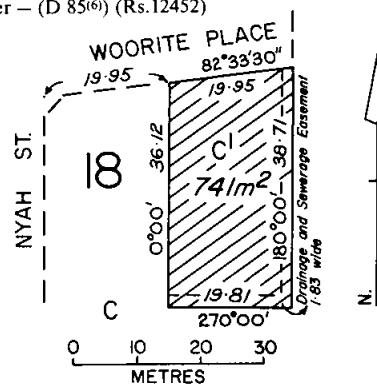

CROWN LAND (RESERVES) ACT 1978

At the Executive Council Chamber, Melbourne, the sixteenth day of August, 1983

Present:

His Excellency the Governor of Victoria
 Mr Cathie | Mr Walker
 | | Mr Mathews

CROWN LAND PERMANENTLY RESERVED

His Excellency the Governor of the State of Victoria, in the Commonwealth of Australia, by and with the advice of the Executive Council of the said State, pursuant to the provisions of sections 4 and 7 of the *Crown Land (Reserves) Act 1978*, and being of the opinion that the Crown land concerned is required for the purpose mentioned, doth hereby permanently reserve and also except from prospecting or from occupation for mining purposes under any miner's right, the Crown lands hereinafter described, viz.:

Municipal District of the Shire of Orbost —
NEWMERELLA — For Management of Wildlife — 950 hectares, more or less, being Crown allotment 4P, section A, Parish of Newmerella, as indicated by hatching on plan hereunder — (N 136⁽⁶⁾) (Rs.11340)

Municipal District of the Shire of Seymour —
TALLAROOK — For Departmental Residence — 678 square metres, being Crown allotment 17A, section I, Parish of Tallarook, as indicated by hatching on plan hereunder — (Parish 3532) (Rs.12429)

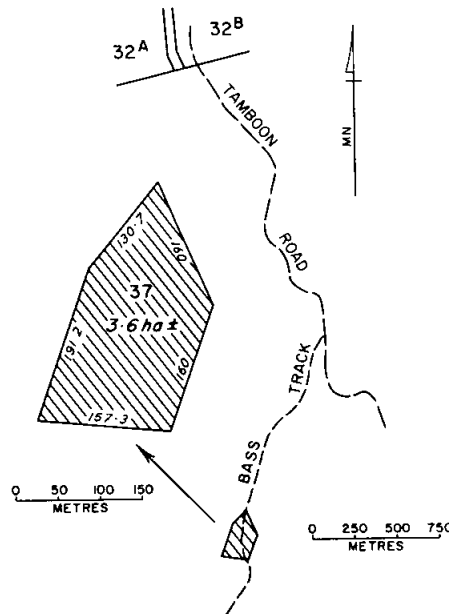
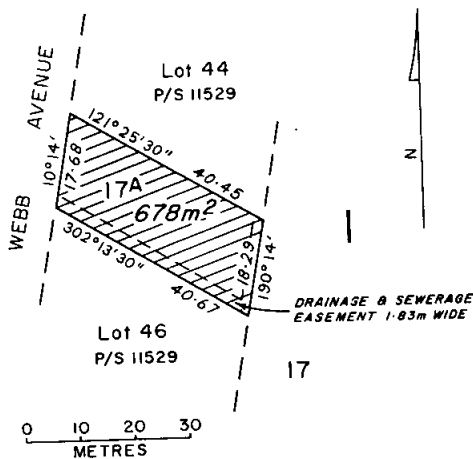

Municipal District of the Shire of Upper Yarra —
WARBURTON — For Victoria State Emergency Service Local Headquarters — 1380 square metres, being Crown allotment 7F, Parish of Warburton, as shown on Certified Plan No. 106108 lodged in the Central Plan Office — (W 348⁽¹⁴⁾) (Rs.12500)

And the Honourable Roderick Alexander Mackenzie, Her Majesty's Minister of Lands for the State of Victoria, shall give the necessary directions herein accordingly.

TOM FORRISTAL
 Clerk of the Executive Council

CROWN LAND (RESERVES) ACT 1978

At the Executive Council Chamber, Melbourne, the sixteenth day of August, 1983

Present:

His Excellency the Governor of Victoria
 Mr Cathie | Mr Walker
 | Mr Mathews

CROWN LANDS TEMPORARILY RESERVED

His Excellency the Governor of the State of Victoria, in the Commonwealth of Australia, by and with the advice of the Executive Council of the said State, pursuant to the provisions of sections 4 and 7 of the *Crown Land (Reserves) Act 1978*, and being of the opinion that the Crown lands concerned are required for the purposes respectively mentioned, doth hereby temporarily reserve and also except from prospecting or from occupation for mining purposes under any miner's right, the Crown lands hereinafter described, viz.:

Municipal District of the Shire of Korong —
INGLEWOOD — For Public Park — 1.3 hectares, more or less, being Crown allotment 30D, section A, Township of Inglewood, as indicated by hatching on plan hereunder — (1 4⁽⁵⁾) (Rs.12464)

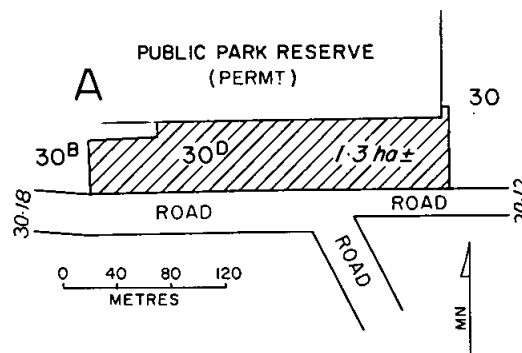

Municipal District of the Shire of Orbost —
TONGHI — For Supply of Gravel — 3.6 hectares, more or less, being Crown allotment 37, Parish of Tonghi, as indicated by hatching on plan hereunder — (T271⁽³⁾) (Rs.12495)

And the Honourable Roderick Alexander Mackenzie, Her Majesty's Minister of Lands for the State of Victoria, shall give the necessary directions herein accordingly.

TOM FORRISTAL
 Clerk of the Executive Council

SUPERANNUATION ACT 1958

*At the Executive Council Chamber, Melbourne, the
sixteenth day of August, 1983*

Present:

His Excellency the Governor of Victoria
Mr Cathie | Mr Walker
Mr Mathews

Pursuant to the powers conferred by the provisions of paragraph (ja) of sub-section (1) of Section 3 of the *Superannuation Act 1958*, His Excellency the Governor of the State of Victoria, by and with the advice of the Executive Council thereof doth by this Order declare that the provisions of the Superannuation Act shall apply to the officers named in the schedule set out hereunder:

Schedule

Tracie Elizabeth Aiken
Motor Accidents Board

Henry Edward Budziszewski
Andrew John Chapman
Kevin Francis Hore
Christopher David Roberts
Robert William Saynor
Road Construction Authority

Richard Norman Barker
Michael Walter Basaranowicz
Petrina Leigh Batt
Brian William Budd
Geoffrey James Burke
Vincent Carbone
Kerry Joy Closter
Percival Noel Da Silva
Robert Gordon Davey
Anne Margaret Dean
Maria Dicurzio
Lourice Michelle Duncan
Kathleen Patricia Elliott
Abdelazim Elmaghraby
Salvatore Failla
Steven Joe Gauci
Greg John Guest
Denise Anne Hocking
Jenette Maree Horwood
Vivian Jansz
Dennis Clyde Jewell
Flavia Lacorcchia
John Michael Loughnan
Cosimo Antonio Marazita
Marina Marguccio
Elizabeth Johanna Marshall
Angelo Risteovski
Debbie June Saville
Maria Seruto
Georgette Shehata
Gordon Francis Smith
Debra Fay Wheeler
Phillip Edward Wilson
Alberto Zapparrata
Road Traffic Authority

Anthony Francis Barratt
Frederick Martin Beale
Peter Frederick Berger
Garron James Buckland
Joseph Calleja
Antonio Capuano
Antoinette Denia

Dinh An Duong
Michael David Henstridge
Loretta Fay Karmistie
Blagoja Mitrevski
Godfrey Basil Parker
Wayne Donald Saunders
Raymond Tanti
Johannes Julius Edward Thiedeman
State Transport Authority

Vicki Lynette Sherriff
Victorian Brown Coal Council

Wendy Ann Clark
Warrnambool Institute of Advanced Education

And the Honourable Robert Allen Jolly, Her Majesty's Treasurer for the State of Victoria, shall give the necessary directions herein accordingly.

TOM FORRISTAL

Clerk of the Executive Council

WORKERS COMPENSATION ACT 1958

*At the Executive Council Chamber, Melbourne, the
sixteenth day of August, 1983*

Present:

His Excellency the Governor of Victoria
Mr Cathie | Mr Walker
Mr Mathews

APPROVAL OF INSURERS

In pursuance of the powers conferred by section 72 of the *Workers Compensation Act 1958*, and all other powers him thereunto enabling, His Excellency the Governor of the State of Victoria, by and with the advice of the Executive Council thereof, doth by this Order:

1. approve the undermentioned companies as "Insurers" for the purposes of the said section from 1 September 1983 to 29 February 1984 —

C. E. Heath Underwriting and Insurance (Australia) Pty. Ltd.
Lombard Insurance Company (Australia) Limited
Manufacturers' Mutual Insurance Limited
The National Insurance Company of New Zealand Limited
National Employers' Mutual General Insurance Association Limited
Preservatrice Skandia Insurance Limited
Provincial Insurance Company Limited
Traders Prudent Insurance Company Limited
Switzerland General Insurance Company Limited; and

2. approve the undermentioned companies as "Insurers" for the purposes of the said section from 1 September 1983 to 31 August 1984 —

A.G.C. Insurances Limited
Allianz Insurance Company Limited
American Home Assurance Company
Ansva Australia Insurance Ltd.
Australian Eagle Insurance Company Limited
The Baltica-Skandinavia Insurance Company Limited
The City Mutual General Insurance Limited
General Accident Fire and Life Assurance Corporation Limited
GRE Insurance Limited
Insurance Company of North America (Australia) Limited
L'Union des Assurances de Paris
The M.L.C. Fire and General Insurance Company Pty. Limited

National and General Insurance Company Limited
 Norwich Winterthur Insurance (Australia) Limited
 Prudential Cornhill Insurance Company of Australia Limited
 Royal Insurance Australia Limited
 Sun Alliance Insurance Limited
 T. & G. Fire and General Insurance Company Limited
 Vanguard Insurance Company Limited
 Zurich Australian Insurance Limited.

And the Honourable Steven Marshall Crabb, Her Majesty's Minister of Transport for the State of Victoria, acting for and on behalf of Her Majesty's Minister of Labour and Industry, shall give the necessary directions herein accordingly.

TOM FORRISTAL
 Clerk of the Executive Council

WORKERS COMPENSATION ACT 1958

At the Executive Council Chamber, Melbourne, the sixteenth day of August, 1983

Present:
 His Excellency the Governor of Victoria
 Mr Cathie | Mr Walker
 | Mr Mathews

APPROVAL OF INSURERS

In pursuance of the powers conferred by section 72 of the *Workers Compensation Act 1958*, and all other powers him thereunto enabling, His Excellency the Governor of the State of Victoria, by and with the advice of the Executive Council thereof, doth by this Order approve the undermentioned companies as insurers for the purposes of the said section until 29 February 1984:

FAI Insurances Limited
 Fire and All Risks Insurance Company Limited.

And the Honourable Steven Marshall Crabb, Her Majesty's Minister of Transport for the State of Victoria, acting for and on behalf of Her Majesty's Minister of Labour and Industry, shall give the necessary directions herein accordingly.

TOM FORRISTAL
 Clerk of the Executive Council

VICTORIAN ARTS CENTRE ACT 1979, No. 9354

At the Executive Council Chamber, Melbourne, the sixteenth day of August, 1983

Present:
 His Excellency the Governor of Victoria
 Mr Cathie | Mr Walker
 | Mr Mathews

APPOINTMENT OF MEMBER OF THE VICTORIAN ARTS CENTRE TRUST

Pursuant to the powers conferred by Section 8 of the *Victorian Arts Centre Act 1979*, No. 9354, His Excellency the Governor of the State of Victoria, by and with the advice of the Executive Council thereof, doth by this Order appoint:

George Seelaf
 to be a Member of the Victorian Arts Centre Trust in accordance with the provisions of sub-section (1) (d) of the said Act, for the period 1 September 1983 to 12 March 1984.

And the Honourable Charles Race Thorson Mathews, Her Majesty's Minister for the Arts for the State of Victoria, shall give the necessary directions herein accordingly.

TOM FORRISTAL
 Clerk of the Executive Council

GEELONG WATERWORKS AND SEWERAGE TRUST

At the Executive Council Chamber, Melbourne, the sixteenth day of August, 1983

Present:
 His Excellency the Governor of Victoria
 Mr Cathie | Mr Walker
 | Mr Mathews

CONSENT TO BORROWING \$2 228 000.00

Under the powers conferred by the Geelong Waterworks and Sewerage Act and all other powers enabling him in that behalf, His Excellency the Governor of the State of Victoria, by and with the advice of the Executive Council of the said State hereby consents to the Geelong Waterworks and Sewerage Trust borrowing the sum of two million two hundred and twenty-eight thousand dollars (\$2 228 000.00) in six separate loans of two hundred thousand dollars (\$200 000.00), one million dollars (\$1 000 000.00), three hundred thousand dollars (\$300 000.00), two hundred and fifty thousand dollars (\$250 000.00), two hundred thousand dollars (\$200 000.00) and two hundred and seventy-eight thousand dollars (\$278 000.00) for the conversion of loan C.11 and to meet the cost of water supply works.

And the Honourable David Ronald White, Her Majesty's Minister of Water Supply for the State of Victoria, shall give the necessary directions herein accordingly.

TOM FORRISTAL
 Clerk of the Executive Council

LAND ACT 1958

At the Executive Council Chamber, Melbourne, the sixteenth day of August, 1983

Present:
 His Excellency the Governor of Victoria
 Mr Cathie | Mr Walker
 | Mr Mathews

UNUSED ROAD CLOSED

His Excellency the Governor of the State of Victoria, in the Commonwealth of Australia, by and with the advice of the Executive Council of the said State, pursuant to the provisions of section 349 of the *Land Act 1958*, and with the concurrence in writing of the council of the municipality concerned and that of any adjoining land owners, doth hereby close the unused road hereinafter described, viz.:

Municipal District of the City of Ballarat —
 Township of Ballarat East, being the road indicated by hatching on plan hereunder — (B 128⁽⁴⁶⁾) (Rs.5838)

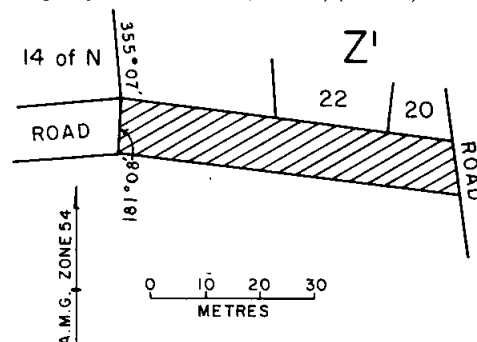

And the Honourable Roderick Alexander Mackenzie, Her Majesty's Minister of Lands for the State of Victoria, shall give the necessary directions herein accordingly.

TOM FORRISTAL
Clerk of the Executive Council

CITY OF PORT MELBOURNE
PARISH OF MELBOURNE SOUTH
COUNTY OF BOURKE

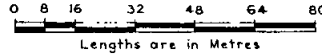

DANDENONG VALLEY AUTHORITY

At the Executive Council Chamber, Melbourne, the
sixteenth day of August, 1983

Present:

| | |
|---|------------|
| His Excellency the Governor of Victoria | |
| Mr Cathie | Mr Walker |
| | Mr Mathews |

CONSENT TO BORROWING \$42 000.00

Under the powers conferred by the Dandenong Valley Authority Act and all other powers enabling him on that behalf, His Excellency the Governor of the State of Victoria, by and with the advice of the Executive Council of the said State, hereby consent to the Dandenong Valley Authority borrowing the sum of forty-two thousand dollars (\$42 000.00) as a conversion loan.

And the Honourable David Ronald White, Her Majesty's Minister of Water Supply for the State of Victoria, shall give the necessary directions herein accordingly.

TOM FORRISTAL
Clerk of the Executive Council

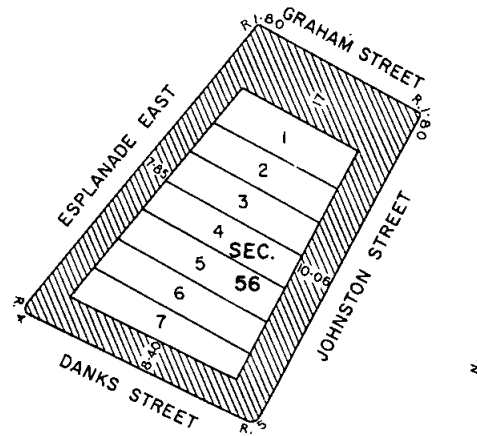

And the Honourable Ian Robert Cathie, Her Majesty's Minister of Housing for the State of Victoria, shall give the necessary directions herein accordingly.

TOM FORRISTAL
Clerk of the Executive Council

HOUSING ACT 1958

At the Executive Council Chamber, Melbourne, the
sixteenth day of August, 1983

Present:

| | |
|---|------------|
| His Excellency the Governor of Victoria | |
| Mr Cathie | Mr Walker |
| | Mr Mathews |

CLOSURE OF PORTIONS OF ROAD – CITY OF
PORT MELBOURNE

Whereas by virtue and in exercise of the powers contained in the *Housing Act 1958* (No. 6275) Housing Commission has recommended to the Governor in Council that the portions of road described in the Schedule hereto be closed.

Now therefore His Excellency the Governor of the State of Victoria, in the Commonwealth of Australia, by and with the advice of the Executive Council of the said State, doth in pursuance of the powers conferred by the said Act and upon such recommendation, consent and by this Order hereby close such portions of road.

Schedule

The portions of road delineated and hachured on the Plan hereunder.

HOUSING ACT 1958

At the Executive Council Chamber, Melbourne, the
sixteenth day of August, 1983

Present:

| | |
|---|------------|
| His Excellency the Governor of Victoria | |
| Mr Cathie | Mr Walker |
| | Mr Mathews |

CLOSURE OF A ROAD – CASTLEMAINE

Whereas by virtue and in exercise of the powers contained in the *Housing Act 1958* (No. 6275) Housing Commission has recommended to the Governor in Council that the road described in the Schedule hereto be closed.

Now therefore His Excellency the Governor of the State of Victoria, in the Commonwealth of Australia, by and with the advice of the Executive Council of the said State, doth in pursuance of the powers conferred by the said Act and upon such recommendation, consent and by this Order hereby close such road.

Schedule

The road delineated and hachured on the Plan hereunder.

PART OF CROWN ALLOTMENT 7
SECTION E
PARISH OF CASTLEMAINE
COUNTY OF TALBOT

SCALE 80 40 0 80 160 FEET

L. P. 33378

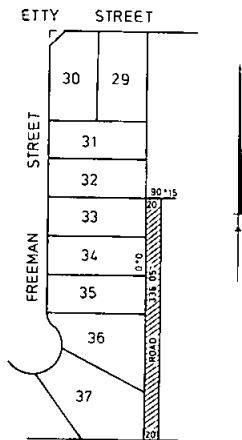

And the Honourable Ian Robert Cathie, Her Majesty's Minister of Housing for the State of Victoria, shall give the necessary directions herein accordingly.

TOM FORRISTAL
Clerk of the Executive Council

WATER ACT 1958
STATE RIVERS AND WATER SUPPLY COMMISSION

At the Executive Council Chamber, Melbourne, the
twenty-third day of August, 1983

Present:

His Excellency the Governor of Victoria

Mr Mackenzie
Mr Simpson

Mr Kent

GOULBURN-MURRAY IRRIGATION DISTRICT —
PORTION EXCISED
RODNEY IRRIGATION AREA — BOUNDARIES
VARIED

Under the powers conferred by the *Water Act 1958* and all other powers enabling him in that behalf, His Excellency the Governor of the State of Victoria, with the advice of the Executive Council of the said State, on the recommendation of the State Rivers and Water Supply Commission, doth hereby declare order and direct that there shall be excised from the Goulburn-Murray Irrigation District the land shown by green colour on a plan approved by the Governor in Council and deposited in the office of the State Rivers and Water Supply Commission at 590 Orrong Road, Armadale (Corr. No. 82/1155) and that the boundaries of the Rodney Irrigation

Area shall be varied to excise therefrom such land which shall be deemed to be excised from the said Irrigation District and Irrigation Area as on and from 31 August 1983.

And the Honourable David Ronald White, Her Majesty's Minister of Water Supply for the State of Victoria, shall give the necessary directions herein accordingly.

TOM FORRISTAL
Clerk of the Executive Council

LANDS DEPARTMENT
NOTICES

APPROACHING LAND SALES

Sale of Crown Land, will be held at the under-mentioned places and dates, viz.:

| | No. of Gazette |
|---|-------------------|
| Colac—Tuesday, 13 September 1983 | 78 |
| Rochester—Monday, 10 October 1983 | 80 |
| Vermont—Saturday, 24 September 1983 | 78 |
| West Meaitan—Tuesday, 13 September 1983 | 72 |

SALE OF CROWN LAND BY AUCTION

The land will be offered for sale subject to the provisions of the Land Act and Regulations thereunder.

The upset price is the sum at which bidding will start, and no bid below that sum can be accepted. The highest bidder at or above that sum shall be the purchaser, subject to signature of contract and any necessary payment.

Terms:

A deposit of at least 12½% of the purchase price must be paid at the sale, either in cash or by cheque.

The residue is payable on 29 December 1983 or may be paid off at any earlier time.

Interest at the rate of 14% per annum is payable on arrears after the due date.

Fees, etc.:

Survey fee is payable at the sale.

Payable with balance of purchase money — Crown Grant fee — \$41.00.

Assurance contribution — One cent in every Five dollars or part thereof of purchase price. (This is to guarantee the validity of freehold titles.)

Transfer of interest prior to completion of payment may be allowed on payment of the prescribed fee and subject to stamp duty.

If unable to attend personally a prospective purchaser may arrange for another person to bid as his agent.

Attention is drawn to section 95, *Land Act 1958*, which provides that the purchaser shall be deemed to be the owner for the purposes of other Acts; also to an amendment to the Local Government Act providing for Government roads, in certain circumstances, to be declared "private streets", thus making the purchaser liable to contribute to the cost of street construction.

R. A. MACKENZIE
Minister of Lands

Department of Crown Land and Survey
Melbourne

UNDERBOOL — Sale (No. 12398) of Crown land, by auction, will be held at the Land Inspector's Office, Mossop Street, Underbool on Friday, 30 September 1983 at 10.30 o'clock a.m. To be conducted by P. J. Richardson, Regional Land Officer, Mildura.

Regulations

RHYLL PUBLIC PARK RESERVE

I, Roderick Alexander Mackenzie, Her Majesty's Minister of Lands in and for the State of Victoria, in pursuance of the powers conferred on me by Section 13 of the *Crown Land (Reserves) Act 1978* do hereby make the following Regulations for or with respect to the Crown land in the Parish of Phillip Island temporarily reserved for a Public Park by Order in Council of 8 February 1983 (vide *Government Gazette* dated 16 February 1983) and hereinafter referred to as the "Reserve".

The Reserve has been placed under the control of the Corporation of the Shire of Phillip Island as Committee of Management (hereinafter referred to as the "Committee") with full power and authority to enforce these Regulations.

Regulations

1. The Reserve shall be open to the public at all times free of charge except on such days as the Committee may set the Reserve or portions thereof aside for the purpose of holding fetes, carnivals, entertainments, musical performances, shows or sports and may grant the use of the portions so set apart to any club, association or person subject to the observance of such terms and conditions and the payment of such fees as may be prescribed by the Committee from time to time.

2. No person shall enter or remain in the Reserve who may offend against decency as regards dress, language or conduct.

3. No person shall damage in any way any tree, shrub or flower in the Reserve, nor light any fire therein without the permission of the Committee.

4. No person shall climb or jump over any gate or fence in or around the Reserve, stick bills thereon, or cut names on or in any way damage or injure any building, gate, fence, seat or tree in the Reserve, nor leave or deposit any glass, paper or rubbish whatsoever therein, or throw any stone or missile of any kind therein except with the permission of the Committee.

5. No person shall put or bring into the Reserve any cattle, horse, sheep, goat, pig or other animal, except any dog controlled by a chain or cord, without the permission of the Committee first obtained.

6. The Committee shall have full power and authority to impound any cattle found trespassing on the Reserve and shall be taken to be the occupier of the Reserve (with all power incidental to that status) within the meaning of any law for the time being in force relating to the impounding of cattle. For the purpose of this clause "cattle" shall mean cattle as interpreted by section 3 of the *Pounds Act 1958*.

7. No person shall camp in the Reserve nor erect therein any dwelling, booth or other structure for the purpose of offering for sale any article whatsoever without the permission, in writing, of the Committee first obtained.

8. No person shall take part in any public entertainment of any sort in the Reserve without the permission of the Committee first obtained.

9. No person shall spit on the paths or on any structure or erection in the Reserve.

10. No person shall bet publicly in any part of the Reserve and every person infringing this Regulation shall be liable to expulsion from the Reserve or parts thereof.

11. Persons occupying or hiring any stand, building, erection or enclosure in the Reserve on the occasions of any fetes, sports or any other holiday amusements may be required to deposit a sum which the Committee may at any time determine, not exceeding \$100, by way of guarantee that due care shall be taken of such stand, building, erection or enclosure, and such Committee, in its absolute discretion, may make good

any damage or loss sustained by such stand, building, erection or enclosure or anything contained therein during such occupancy or hiring and deduct the cost of making good such loss or damage from the sum of money deposited by way of guarantee, and all persons so occupying or hiring shall abide by these Regulations and by any lawful order given by the Committee — (RS808).

Given under my hand at Melbourne on 15 August 1983

R. A. MACKENZIE
Minister of Lands

Every person who contravenes or fails to comply with these Regulations shall be liable to the penalties prescribed in Section 13 of the *Crown Land (Reserves) Act 1978*.

TENDERS

PUBLIC WORKS DEPARTMENT

Tenders are invited for the purposes indicated hereunder and will be received at 2 Treasury Place, Melbourne, 3002, until TWO p.m. on dates shown.

Tenders must be addressed to the Minister of Public Works with the envelope endorsed "Tender for

". Hand-delivered tenders must be placed in the Department's tender box in foyer, Ground Floor, 2 Treasury Place, Melbourne.

Tender documents are available from the Contracts Office, Room 29, 2 Treasury Place, Melbourne and where indicated, at offices of Inspectors of Works.

Tenders for works identified with star () will only be considered from Contractors qualified for repairs and painting works. Any Tenderers wishing to qualify may obtain the application form from the Contracts Office.

Wednesday, 7 September 1983

Building, Electrical and Mechanical Works

BIRCHIP—Woodwork/metalwork, home economics, graphics, art, fabrics, textiles, Community Education Complex. (W.O., Horsham.)

BRUNSWICK SOUTH—Stage 1—Upgrade—2 storey building, improvement of Staff/Admin. and Art/Craft facilities, Primary School.

*LATROBE—Internal repairs and painting to toilets, High School.

ROYAL PARK—Upgrade of main kitchen, supply and installation of stainless steel benchwork and kitchen equipment, Psychiatric Hospital.

WANGARATTA—Installation of an intruder detection system, High School.

Siteworks

GREYTHORN—Removal of trees, High School.

Miscellaneous

LILYDALE—Maintenance cleaning, Soil Conservation Authority Office, Hardy Street, Ministry of Conservation. (Police Station, Lilydale.)

MIDDLE PARK—Maintenance cleaning, 104 Ashworth Street, Health Commission.

BENDIGO—Supply and install curtains T1203/7/9 Psychiatric Centre.

COWES—Maintenance cleaning, Fisheries and Wildlife and Police Station, corner Chapel and Osborne Streets. (Police Station, Cowes.)

DROMANA—Maintenance cleaning, Court House, Codrington Street, Law Department. (W.O., Mornington.)

LARA—Maintenance cleaning, Police Station, Police and Emergency Services. (W.O., Geelong.)

VARIOUS—Supply and delivery of sole plates and brackets, various sites, Education Department.

Wednesday, 14 September 1983

Building, Electrical and Mechanical Works

BROADMEADOWS WEST—Floor coverings, Technical School.
 FAWKNER NORTH—Gas conversion of furnaces for heating systems, Primary School.

KENSINGTON—Installation of an intruder detection system, Primary School.

★SOUTHMOOR—(Re-advertisement)—External cyclic maintenance, Primary School.

★STRATHEWEN—Internal and external repairs and painting, Primary School.

THORNBURY—Floor treatment, High School.

TRARALGON—Improvements to cell block and fencing, Police Station, Kay Street. (W.O., Traralgon.)

VARIOUS—Contract 4, 83/84—Supply and delivery of 55 No. modular buildings, F.O.G., storeyard, 69 Salmon Street, Port Melbourne. (W.O., Bendigo, Ballarat and Geelong.)

Siteworks

NARINGAL—New fire services, Primary School. (W.O., Warrnambool.)

SYDENHAM—Connection of town water, Primary School.

Miscellaneous

MALVERN—Maintenance cleaning, C.I.B. offices, Glenferrie Road, Police and Emergency Services.

MELBOURNE—Maintenance cleaning, 49 Spring Street, Public Offices.

PORT MELBOURNE—Supply of twenty (20) chain saws, store-yard, 69 Salmon Street.

WESTMEADOWS—Maintenance cleaning, Police Station, Police and Emergency Services.

JACK SIMPSON, M.P.
 Minister of Public Works

Public Works Department
 Melbourne, 23 August 1983

LATE NOTICE

Transport Act 1983

**ROAD TRAFFIC AUTHORITY
 PASSENGER FERRY APPLICATIONS**

Notice is hereby given that the following applications will be considered by the State Transport Authority on 13 September 1983.

Notice of any objections should be forwarded to reach the Officer in Charge, Passenger and Goods Division, Road Traffic Authority not later than 7 September 1983.

It will not be necessary for interested parties to appear on the hearing date specified, unless advised in writing by the Road Traffic Authority.

Chelfco 94 Pty. Ltd., Trading as Cowes Ferry Service, Phillip Island.

Application to license two ferries to operate for the carriage of passengers and goods between Cowes, Phillip Island, Tankerton, French Island and Stony Point on the mainland, one with facilities to accommodate 178 passengers and one with facilities to accommodate 50 passengers.

Note:

The applicant provides the existing ferry service between Cowes, Tankerton and Stony Point.

| <i>Fares:</i> | <i>Single</i> | <i>Return</i> |
|---------------|---------------|---------------|
| | \$ | \$ |
| Adults | 3.00 | 5.00 |
| Children | 2.00 | 3.00 |
| Surfboards | .50 | 1.00 |
| Animals | .50 | 1.00 |
| Bikes | 1.00 | 2.00 |

Note:

Group Travel 10 or more a discount of 10%. These rates apply to both French Island and Cowes.

Freight:

| | |
|---------------|-------|
| Up to 5 kg | 1.00 |
| 5 kg to 15 kg | 2.00 |
| Half a tonne | 15.00 |
| One tonne | 30.00 |

Timetable:

| A | <i>Winter</i> | <i>Monday-Saturday</i> | | | | <i>Sunday</i> | | |
|--------|---------------|------------------------|-------------|------------|-----------|---------------|------------|-----------|
| Depart | Stony Point | 9.00 a.m. | 10.15 a.m. | 4.00 p.m. | 5.00 p.m. | 9.00 a.m. | 10.15 a.m. | 5.40 p.m. |
| | Tankerton | 9.20 a.m. | 10.35 a.m. | 4.20 p.m. | 5.20 p.m. | 9.20 a.m. | 10.35 a.m. | 6.05 p.m. |
| Arrive | Cowes | — | 11.00 a.m. | — | — | — | — | 6.30 p.m. |
| Depart | Cowes | — | 11.15 a.m. | — | — | — | — | 4.30 p.m. |
| | Tankerton | 9.20 a.m. | 11.45 a.m. | 4.20 p.m. | 5.20 p.m. | 9.20 a.m. | 10.35 a.m. | 5.00 p.m. |
| Arrive | Stony Point | 9.40 a.m. | *12.00 noon | *4.40 p.m. | 5.40 p.m. | 9.40 a.m. | 11.00 a.m. | 5.20 p.m. |

| B Summer (1 Dec-28 Feb) | | Monday-Saturday | | Sunday | |
|-------------------------|-------------|-----------------|------------|-------------|------------|
| Depart | Cowes | 8.45 a.m. | 3.45 p.m. | 9.45 a.m. | 4.30 p.m. |
| | Tankerton | 9.15 a.m. | 4.15 p.m. | 10.15 a.m. | 5.00 p.m. |
| Arrive | Stony Point | *9.45 a.m. | *4.45 p.m. | *10.45 a.m. | *5.30 p.m. |
| Depart | Stony Point | *10.15 a.m. | *5.10 p.m. | *11.15 a.m. | *5.40 p.m. |
| | Tankerton | 10.45 a.m. | 5.40 p.m. | 11.45 a.m. | 6.05 p.m. |
| Arrive | Cowes | 11.15 a.m. | 6.10 p.m. | 12.15 p.m. | 6.30 p.m. |

*Train connection at Stony Point
Additional service may be provided for groups that pre-book.

J. E. & T. J. Squire, Crib Point

Application to license two ferries, to operate for the carriage of passengers and goods between Stony Point on the mainland and Tankerton Jetty on French Island, one with facilities to accommodate 63 passengers and one with facilities to accommodate 45 passengers.

Note:

The applicant provides the existing ferry service between Stony Point and Tankerton Jetty, French Island.

| Timetable: | Every Day of the Year |
|--------------------|-----------------------|
| Depart Stony Point | Depart French Island |
| 7.00 a.m. | 7.25 a.m. |
| 9.00 a.m. | 9.25 a.m. |
| *10.00 a.m. | *10.25 a.m. |
| 4.00 p.m. | 4.25 p.m. |
| *5.00 p.m. | *5.25 p.m. |

*Service on these trips when required.

| Fares: | Single | Return |
|---------------------|-----------|--------|
| | \$ | \$ |
| Adult | 3.00 | 5.00 |
| Child | 2.00 | 3.00 |
| Child under 5 years | No charge | |

Charges:

| | |
|--------------------------|---------|
| For return carriage | |
| Large road motor cycles | \$15.00 |
| Trail Bikes (full size) | 10.00 |
| Trail Bikes (small size) | 5.00 |
| Pedal Cycles | 2.00 |

Peninsula Searoad Transport Pty. Ltd., Bentleigh

Application to license a passenger and vehicle ferry, to be constructed, to operate between Queenscliff and Sorrento via the southern area of Port Phillip Bay, with facilities to accommodate 260 passengers and 39 vehicles (subject to the size of the vehicles).

Timetable:

Summer Timetable 7 days per week

| Queenscliff | Sorrento | Sorrento | Queenscliff |
|---------------|---------------|---------------|---------------|
| Dep 6.00 a.m. | Arr 6.40 a.m. | Dep 7.00 a.m. | Arr 7.40 a.m. |
| 8.00 a.m. | 8.40 a.m. | 9.00 a.m. | 9.40 a.m. |
| 10.00 a.m. | 10.40 a.m. | 11.00 a.m. | 11.40 a.m. |
| 12.00 noon | 1.40 p.m. | 1.00 p.m. | 1.40 p.m. |
| 2.00 p.m. | 2.40 p.m. | 3.00 p.m. | 3.40 p.m. |
| 4.00 p.m. | 4.40 p.m. | 5.00 p.m. | 5.40 p.m. |

Winter Timetable 7 days per week

| Queenscliff | Sorrento | Sorrento | Queenscliff |
|---------------|---------------|---------------|---------------|
| Dep 8.00 a.m. | Arr 8.40 a.m. | Dep 9.00 a.m. | Arr 9.40 a.m. |
| 12.00 noon | 12.40 p.m. | 1.00 p.m. | 1.40 p.m. |
| 4.00 p.m. | 4.40 p.m. | 5.00 p.m. | 5.40 p.m. |

| Fares: | Single | |
|-------------------|---------|---------------------------------|
| Per Passenger | \$3.00 | |
| Per Vehicle | \$12.00 | (1 vehicle covers 4 Passengers) |
| Per Tourist Coach | \$50.00 | |

Neale Cruisers Pty. Ltd., Sorrento

Application to license two passenger ferries to operate between Sorrento, Portsea and Queenscliff piers, one with facilities to accommodate 190 passengers and one with facilities to accommodate 160 passengers.

Note:

The applicant provides the existing ferry service between Sorrento, Portsea and Queenscliff.

| <i>Fares:</i> | <i>Single</i> | <i>Return</i> |
|---------------------|---------------|---------------|
| | \$ | \$ |
| Adult | 3.00 | 5.00 |
| Pensioner | 2.00 | 4.00 |
| Child | 2.00 | 3.00 |
| Child under 5 years | No Charge | |

*Timetable:**Weekends (Cup Day Weekend to Xmas)*

| | | | | |
|-----|-------------|------------|-----------|-----------|
| Dep | Sorrento | 11.00 a.m. | 1.00 p.m. | 3.00 p.m. |
| | Portsea | 11.15 a.m. | 1.15 p.m. | 3.15 p.m. |
| | Queenscliff | 12.00 noon | 2.00 p.m. | 4.00 p.m. |

*1 Feb to Good Friday**(Xmas Timetable — East Sat. Sun & Mon)*

| | | | | | | |
|-----|-------------|-----------|------------|------------|-----------|-----------|
| Dep | Sorrento | 8.45 a.m. | 10.20 a.m. | 12.10 p.m. | 2.00 p.m. | 4.00 p.m. |
| | Portsea | 9.00 a.m. | 10.35 a.m. | 12.25 p.m. | 2.15 p.m. | 4.15 p.m. |
| | Queenscliff | 9.30 a.m. | 11.10 a.m. | 1.10 p.m. | 3.00 p.m. | 4.50 p.m. |

26 December to 31 January:

| | | | | | | | | | |
|-----|-------------|-----------|------------|------------|------------|------------|-----------|-----------|-----------|
| Dep | Sorrento | 8.30 a.m. | 9.00 a.m. | 10.00 a.m. | 11.00 a.m. | 12.00 noon | 1.00 p.m. | 2.00 p.m. | 3.00 p.m. |
| | Portsea | — | 9.15 a.m. | 10.15 a.m. | 11.15 a.m. | 12.15 p.m. | 1.15 p.m. | 2.15 p.m. | 3.15 p.m. |
| | Queenscliff | 9.00 a.m. | 10.00 a.m. | 11.00 a.m. | 12.00 noon | 1.00 p.m. | 2.00 p.m. | 3.00 p.m. | 4.00 p.m. |
| Dep | Sorrento | 4.00 p.m. | 5.00 p.m. | | | | | | |
| | Portsea | 4.15 p.m. | 5.15 p.m. | | | | | | |
| | Queenscliff | 5.00 p.m. | 5.40 p.m. | | | | | | |

School Holiday

8 May to 22 May, 21 August to 4 September

| | | | | | |
|-----|-------------|------------|------------|-----------|-----------|
| Dep | Sorrento | 9.00 a.m. | 11.00 a.m. | 1.00 p.m. | 3.00 p.m. |
| | Portsea | 9.15 a.m. | 11.15 a.m. | 1.15 p.m. | 3.15 p.m. |
| | Queenscliff | 10.00 a.m. | 12.00 noon | 2.00 p.m. | 4.00 p.m. |

C. J. V. SMITH, Chief General Manager, Registration and Regulation, Corner Lygon and Princes Streets, Carlton 3053, 24 August 1983.

Transport Act 1983

ROAD TRAFFIC AUTHORITY

Commercial Passenger and Goods Vehicle Applications

Notice is hereby given that the following applications will be considered by the Road Traffic Authority on 13 September 1983.

Notice of any objections should be forwarded to reach the Officer in Charge, Passenger and Goods Division not later than 7 September 1983.

It will not be necessary for interested parties to appear on the hearing date specified, unless advised in writing by the Authority.

Notification of the date for consideration of applications which are objected to and which will require determination by the Road Transport Licensing Tribunal will be published by further notice in this *Gazette*.

B. J. Bishop, Epping — Application to license a tow truck, to be purchased, to operate throughout the State of Victoria, in the course of business as a "Motor Wrecker" for the purposes of collecting damaged or disabled motor vehicles, but not to include the ability to attend the scenes of accidents for the purposes of lifting and towing motor vehicles involved in any such accidents.

M. J. P. Bristow, South Yarra — Application for two Special Purpose Vehicle licences in respect of a 1954 Bentley sedan and a 1981 Fairlane sedan each with a seating capacity for four persons, to operate from 5 Howards Street, South Yarra, for the carriage of passengers for wedding parties.

T. K. Brown, Coleraine — Application to license a tow truck to operate throughout the State of Victoria solely:

- (a) For the purpose of lifting and carrying or towing of wrecked or disabled motor vehicles and the carriage of tools and equipment necessary for such purposes; and
- (b) The carriage of spare parts necessary for the repair of disabled motor vehicles to and from the place at which such disablement occurred.

E. A. Bryant, Ceres — Application for one Special Purpose Vehicle licence in respect of a 1971 Rolls Royce saloon with seating capacity for five persons to operate from "Foymount", Barrabool Road, Ceres, for the carriage of passengers associated with weddings, anniversaries and special promotion work.

Donric Pty. Ltd., Sunbury — Application to license one commercial passenger vehicle with large seating capacity, to be purchased, to operate for the carriage of school children between Sunbury and Essendon schools via Sydenham and North Keilor regional colleges, under the same terms and conditions as licence TS 1859. No charter rights are sought in this application.

Eagle Auto Panel Pty. Ltd., Shepparton — Application to license a tow truck, to be purchased, to operate within a 90 km radius of own premises at Shepparton as a Restricted Tow Truck for the purpose of towing wrecked or disabled motor vehicles, spare parts, tools of trade and equipment incidental thereto, excluding the ability to attend the scene of a motor vehicle accident.

R. J. Graham, Newcomb — Application to license a tow truck to operate throughout the State of Victoria as a Class 1 tow truck, with a load capacity of 2 tonnes, for the purpose of lifting and carrying or towing and/or repairing wrecked or disabled motor vehicles, tools of trade, spare parts and materials incidental thereto; but excluding the right to attend the scene of a motor vehicle accident unless bespoken.

K. G. and C. G. Hardie, Queenscliff — Application to license a tow truck to operate within a 30 km radius of Queenscliff for the purpose of lifting and carrying or towing and/or repairing wrecked or disabled vehicles, tools of trade, spare parts and materials incidental thereto.

A. J. Harmer, The Basin — Application to license one double-decker bus with seating capacity for 22 persons, to operate under charter conditions throughout the State of Victoria.

A. R. Harris, Kerang — Application to license a tow truck, to be purchased, to operate throughout the State of Victoria, for the purpose of towing damaged or disabled motor vehicles and tools of trade and spare parts incidental thereto.

L. Kennedy, Ballarat — Application to license a tilt tray tow truck to operate throughout the State of Victoria as a Restricted Tow Truck for the lifting and carrying or towing and/or repairing of wrecked or disabled vehicles, tools of trade, spare parts and materials incidental thereto. Operations shall only occur from the scene of a motor car accident if the owner or certificated driver of the tow truck has been previously bespoken, but not at the scene of such accident by the owner of the damaged or disabled motor car or his agent, or person in charge of the said damaged or disabled motor car.

Langdon's Bus Lines Pty. Ltd., Myrtleford — Application for variation of the conditions of licence TS 620, which authorizes an Education Department school contract service between Buffalo River Road and Myrtleford and charter of Myrtleford and licence TS 205 which authorizes an Education Department school contract service between Nug Nug and Myrtleford, to transfer the charter rights attached to licence TS 620 to licence TS 205. The vehicle licensed by TS 205 would hold a four star rating for charter purposes.

London Transport Bus Tours Pty. Ltd., Aspendale — Application for variation of the conditions of licence TO 88 which authorizes various tours of the Melbourne and Metropolitan area and charter within a 40 km operational radius of the G.P.O. Melbourne to extend the operational radius to 55 km.

A. J. Rae, Koondrook — Application to license a tow truck, to be purchased, to operate as follows:

- (a) Within a 20 km radius of Koondrook for the purpose of towing damaged and disabled motor vehicles.
- (b) Within a 300 km radius of Koondrook, excluding all operations within an 80 km radius of Melbourne, for the purpose of towing damaged and disabled motor vehicles excluding the ability to attend the scene of a motor vehicle accident.

A. R. Saunders, Hurstbridge — Application to license a tow truck, to be purchased, to operate throughout the State of Victoria for the purpose of lifting and carrying or towing and/or repairing of wrecked or disabled vehicles, tools of trade, spare parts and materials incidental thereto, but not to tow from motor vehicle accidents in Metro Zoned Areas System.

Application for renewal of licences as shown by the persons listed hereunder to operate under the same terms and conditions.

W. Daly on behalf of Assumption College, Kilmore — SV 255.

J. W. Gardner, Snake Valley — TS 963.

Point Cook-Werribee Passenger Service Pty. Ltd., Werribee — MC 408, MC506.

R. H. Poynton and C. D. McKenzie, Warburton — CT 70.

T. J. and W. O. Yung, Coleraine — TS 741.

24 August 1983

C. J. V. SMITH, Chief General Manager
Registration and Regulation

**PRIVATE
ADVERTISEMENTS**

CITY OF BROADMEADOWS

Order changing name of street

In accordance with the provisions of Section 535 (4A) of the *Local Government Act 1958*, the Council of the City of Broadmeadows hereby gives notice that at its meeting of 15 August 1983, made an Order changing the name of the following street:

Old Name — (Unnamed)

New Name — O'Mara Street

Location — Between Pitt Street and Frederick Street, Fawkner.
8461 B. D. McGREGOR, Town Clerk

CITY OF BRUNSWICK

Loan No. 135

*Notice of Intention to Borrow the Sum of \$1 000 000 for
Permanent Works and Undertakings*

Notice is hereby given that the Council of the City of Brunswick proposes to borrow the principal sum of \$1 000 000 secured by a charge over the general rates of the municipality, such sum to be raised by the grant of a mortgage in accordance with the provisions of the *Local Government Act 1958*.

1. The maximum rate of interest that may be paid is 14.8 per cent per annum.

2. The purposes for which the loan is to be applied are:

Road Reconstruction and drainage:

| | \$ |
|---|-----------|
| Frith Street | 70 000 |
| Howarth Street (Frith Street to Beith Street) | 50 000 |
| Florence Street | 40 000 |
| Little Miller Street | 30 000 |
| Tinning Street (Sydney Road to Railway Line) | 110 000 |
| Kirkdale Street | 145 000 |
| Stanley Street | 135 000 |
| Prentice Street | 70 000 |
| Union Street (Grantham Street to Manica Street) | 50 000 |
| Albert Street Depot Redevelopment (part cost) | 187 000 |
| Mechanics' Institute Improvements | 45 000 |
| Computer Processing and Office Equipment | 68 000 |
| | 1 000 000 |

3. The period of the loan shall be five years.

4. The monies borrowed shall be repayable by providing out of the Municipal Fund nine half-yearly instalments of \$97 347.41 each including principal and interest on 1 April and 1 October during the currency of the loan and a final instalment of \$768 609.80 on 1 October 1988. The first instalment shall be payable on 1 April 1984.

5. Such monies shall be repayable to the Commonwealth Savings Bank of Australia, Melbourne.

The plans and specifications and the estimate of cost of the proposed works and a statement showing the proposed expenditure of the monies to be borrowed are open for inspection at the office of the Council of the City of Brunswick, at 233 Sydney Road, Brunswick.

8517

K. D. WILSON, Town Clerk

CITY OF FOOTSCRAY

By-Law No. 319

Fencing of Vacant Land By-Law

Notice is hereby given that the Council of the City of Footscray has made and passed a By-Law under the provisions of the *Local Government Act 1958*, entitled Fencing of Vacant Land By-Law and numbered 319 for requiring that vacant land within any area within the municipal district set forth in this By-Law and declared herein to be a populous or residential area shall be enclosed with a substantial fence constructed of such material and in such manner as is prescribed by this By-Law.

A copy of the By-Law is open for inspection free of charge during office hours (Monday to Friday 8.30 a.m.-5.02 p.m.) at the Office of the Council, Town Hall, Napier Street, Footscray.

8462

B. J. WARD, Town Clerk

CITY OF KEILOR

Loan No. 169

Notice of Intention to Borrow the Sum of \$450 000 for Permanent Works and Undertakings

Notice is hereby given that the Council of the City of Keilor intends to borrow the principal sum of \$450 000 secured by a charge over the general rates of the municipality, such sum to be raised by the grant of a mortgage in accordance with the provisions of the *Local Government Act 1958*.

1. The maximum current rate of interest that may be paid is 15.2 percent per annum.

2. Such monies shall be repayable at the Commonwealth Savings Bank of Australia, Niddrie Branch.

3. The loan is to be liquidated by providing initially out of the Municipal Fund nine half-yearly instalments of approximately \$44 477.73 each including principal and interest, and payable on 1 April and 1 October during the currency of the loan. The first such instalment shall be payable on 1 April 1984. On 1 October 1988, a final balance of \$348 387.30 will be re-negotiated at prevailing interest rates for a further five years.

4. The purposes for which the loan is to be applied are:

The redevelopment of the St Albans and East Keilor Swimming Centres incorporating additional recreational facilities (Total Cost \$1 750 000.00) (Part Cost \$450 000).

5. The loan is a five year notional 10 year loan with the balance of \$348 387.30 re-negotiable at the end of five years.

6. The plans, specifications, estimate of the cost of the proposed works and a statement showing the proposed expenditure of the monies to be borrowed are open for inspection at the Municipal Offices, Keilor.

Dated 18 August 1983.

R. F. B. KELLY, Town Clerk/Chief Executive Officer

8476

Town and Country Planning Act 1961

SHIRE OF KILMORE PLANNING SCHEME 1973

Notice that a Planning Scheme has been prepared and is available for inspection.

Amendment No. 55, 1983

Notice is hereby given that the Shire of Kilmore in pursuance of its powers under the *Town and Country Planning Act 1961*, has prepared a Planning Scheme for land described as follows — (east of Freeway). Part of Crown Allotments 30, 33, 35, 22, 18 and 19 and Crown Allotments 26, 27, 52 and 53 being 349 ha (862 acres). Also land (west of Freeway) being part of Crown Allotments 25, 30, 33 and 35 being 51 ha (126 acres), Parish of Wallan Wallan. The purpose of the Scheme is to rezone the said land from its present zoning of Rural A1 to "Tourist Zone (Transport)".

A copy of the said Scheme has been deposited at the office of the Shire of Kilmore, Civic Centre, Sydney Street, Kilmore and at the office of the Department of Planning, 500 Collins Street, Melbourne, and will be open for inspection during office hours by any person free of charge.

Any persons affected by the Planning Scheme are required to set forth in writing all objections they may have addressed to the Shire Secretary, Shire of Kilmore, Civic Centre, Kilmore on or before 26 September 1983 and to state whether they wish to be heard in respect to their objections.

8431

T. K. HAYES, Shire Secretary

SHIRE OF KILMORE

Loan No. 90

Notice of Intention to Borrow the Sum of \$28 000 for Permanent Works and Undertakings

Notice is hereby given that the Council of the Shire of Kilmore proposes to borrow the principal sum of \$28 000 secured by a charge over the general rates of the municipality, such sum to be raised by a grant of a mortgage in accordance with the provisions of the *Local Government Act 1958*.

1. Maximum rate of interest that may be paid is 15% per annum.

2. Purpose for which the loan is to be applied for is:

\$

Stage 3 Development, Kilmore Leisure Centre 8 000
Capital Improvements, Apex Park, Kilmore 20 000

3. The period of the loan shall be four years.

4. The monies borrowed shall be repayable by providing out of the Municipal Funds seven half yearly instalments of \$2 746.58 including principal and interest on 6 April and 6 October each year during the currency of the loan with a residual payment of \$23 992.17. The first instalment shall be repayable on 6 April 1984.

5. Such monies are to be repayable to the National Australia Savings Bank Ltd., Sydney St., Kilmore.

The plans and specifications and the estimates of the costs of the proposed works and a statement showing the proposed expenditure of the monies to be borrowed are open for inspection at the office of the Shire of Kilmore, Cnr. of Sydney and Bourke Streets, Kilmore.

8447

T. K. HAYES, Shire Secretary

SHIRE OF KOWREE

By-Law No. 43

Notice is hereby given that the Council of the Shire of Kowree has resolved to make a By-Law No. 43 for:

- (a) Regulating the management and control of library services provided by the Council;
- (b) Imposing penalties not exceeding \$100 for breaches of this By-Law

and that confirmation of the resolution will be made at the meeting of Council to be held on Monday, 5 September 1983 at 11.30 a.m.

A copy of this By-Law may be inspected at the Shire Office, Elizabeth Street, Edenhope during normal office hours.

8448 D. R. GLISSON, Shire Secretary

SHIRE OF KOWREE

Loan No. 36

Notice of Intention to Borrow the Sum of \$25 000 for Permanent Works and Undertakings

Notice is hereby given that the Council of the Shire of Kowree proposes to borrow the principal sum of \$25 000 secured by a charge over the general rates of the municipality, such sum to be raised by the grant of a mortgage in accordance with the provisions of the *Local Government Act 1958*.

1. The maximum rate of interest that may be paid is 15% per annum.
2. The purpose for which the loan is to be applied is part cost of the provision of footpaths in Elizabeth Street, Edenhope.
3. The period of the loan shall be four years based on a twenty year repayment schedule.
4. The monies borrowed shall be repayable by providing out of the Municipal Fund seven equal half-yearly instalments of \$1 985.01 and one instalment of \$25 835.82 each comprising both principal and interest, on 30 September and 30 March in each year during the currency of the loan. The first instalment shall be repayable on 30 March 1984.
5. Such monies shall be repayable at the National Australia Bank, Melbourne or at the Council's Bankers for the time being at Edenhope.

The plans and specifications and an estimate of cost of the proposed works and a statement showing the proposed expenditure of the monies to be borrowed are open for inspection at the Shire Office, Elizabeth Street, Edenhope.

8449 D. R. GLISSON, Shire Secretary

CITY OF OAKLEIGH

Loan No. 171

Notice of Intention to Borrow

Notice is hereby given that the Council of the City of Oakleigh intends to borrow \$150 000 secured by a charge over the general rates of the municipality, such sum to be raised by the grant of a mortgage in accordance with the provisions of the *Local Government Act 1958* (as amended).

In connection therewith, the following information is stated:

- (a) The amount of the principal monies which it is proposed to borrow is \$150 000.
- (b) The rate of interest that may be paid is 15.8 per centum per annum.
- (c) The times the monies borrowed are to be repayable are 2 May and 2 November during the years 1984 to 1999, and the place monies shall be repayable is the Local Authorities Superannuation Board, Queens Road, Melbourne.

- (d) The purpose for which the loan is to be applied is as follows:

Matching Road Construction Authority Grants \$150 000

- (e) The manner in which the loan is to be liquidated is by the provision out of the Municipal Fund each half year during the currency of the loan of the sum of \$13 198.60 which includes principal and interest.

The plans and specifications and estimate of the cost of works and a statement showing the proposed expenditure of the monies to be borrowed are open for inspection at the Municipal Offices, Atherton Road, Oakleigh.

8477 B. R. PREBBLE, Town Clerk

CITY OF PRAHRAN

Declaration of Land as a Public Highway

Pursuant to the provisions of Section 522 of the *Local Government Act 1958*, the Council of the City of Prahran hereby directs that the land in the Parish of Prahran indicated by the hatching on the diagram hereunder, which has been acquired by the Council, shall be a public highway on and from the date of publication of this Order in the *Government Gazette*.

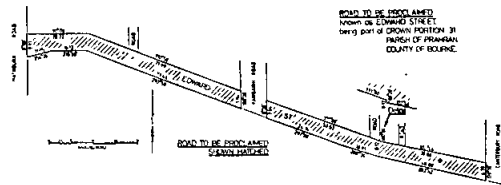

8486 D. G. JESSON, Town Clerk

CITY OF ST. KILDA

Notice of Compulsory Acquisition of Land

Whereas the Council of the City of St. Kilda is expedient to exercise its power of taking compulsorily the land situated at St. Kilda, and being the land described hereunder.

The hiatus shown on the City of St. Kilda plan F257 immediately south of the City of St. Kilda property described in Certificate of Title Volume 1741 Folio 153 being part of Crown Portion 158B East of St. Kilda Parish of Prahran, located 159.63 metres south of Inkerman Street and shown by hatching on the plan at the foot hereof.

The land to be acquired is to be used for the purpose of drainage of stormwater from Chusan Street and other lands draining into the Chusan Street reserve and whereas the Council has cause to prepare a plan and other papers setting out the general description of the drainage undertaking for which the land proposed to be taken, is to be used the description of the land proposed to be taken and the names of the owners or reputed lessees, mortgagees and occupiers of that land so far as those names are known to or, can be ascertained by the Council and whereas the said map and other papers are deposited at the Office of the said Council at St. Kilda and are and shall be open for inspection by all persons interested at all reasonable hours for the space of forty clear days after the publication of this notice in the *Government Gazette* now notice is hereby given to all persons affected by the proposed taking of the said land to set forth in writing addressed to the Council or Town Clerk within forty clear days of the publication of this notice in the *Government Gazette* all objections which they may have to the taking of the said land.

8 August 1983.

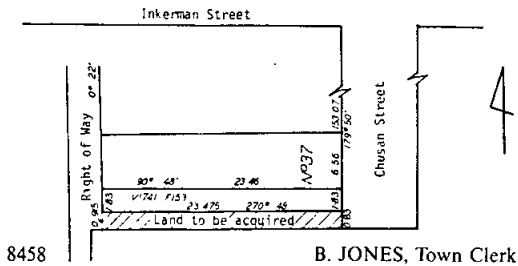

8458 B. JONES, Town Clerk

SHIRE OF BRIGHT
Allocation of Street Names

Notice is hereby given that the Council of the Shire of Bright, pursuant to the provisions of the *Local Government Act 1958*, as amended, has resolved to allocate the following street names:

- (i) Old Name: Un-named Government Road.
New Name: Wilson Court.
Description: The street running in a generally east-west direction off the east side of Hawthorn Lane, Bright, between Cobden Street and Morses Creek, and along the boundary of Crown Allotments 7A and 7F, Section G, Parish of Bright.
- (ii) Old Name: Un-named Government Road.
New Name: Junction Lane.
Description: The lane running in a north-south and then an east-west direction off the south side of the Ovens Highway, Porepunkah, between Crown Allotments 1 and 2, Section 1A, Parish of Porepunkah.

Dated 18 August 1983

H. J. WILLIAMS
Shire Secretary/Chief Executive Officer

Shire Offices, Bright 3741 8478

SHIRE OF MINHAMITE
Prosecuting Officer

Notice is hereby given that Senior Constable Alan Leslie Watt, No. 16324, has been appointed Prosecuting Officer for Shire of Minhamite in lieu of Senior Constable Engburtus Johannes Telgenkamp, No. 15564.

8432 R. J. TOWLER, Shire Secretary

SHIRE OF MORWELL

Notice of the making of a By-Law

By-Law No. 60 Crinigan Road Reserve By-Law

The Council of the Shire of Morwell by resolution made on 7 July 1983 and confirmed on 4 August 1983 has made By-Law No. 60 for the purpose of:

- (a) Preserving public decency.
- (b) Suppressing nuisances.
- (c) Controlling and managing and preserving Commons and Public Reserves of which the management is vested in the Council.
- (d) Regulating the conduct of persons using or being upon or in any grounds or places of public resort or public recreation vested in or rented by the Municipality and requiring such persons to comply with the directions or any signs which the Council has caused to be displayed in the grounds or places.

This By-Law shall come into operation on the day after this notice is published in the *Government Gazette*, viz: 24 August 1983.

A copy of the By-Law is available for inspection, free of charge, during office hours at the Municipal Offices, Civic Centre, Princes Highway, Morwell.

8433 A. R. BAWDEN, Acting Municipal Clerk

SHIRE OF SHERBROOKE

Loan No. 175

Notice of Intention to Borrow the Sum of \$48 000 for Permanent Works and Undertakings

Notice is hereby given that the Council of the Shire of Sherbrooke proposes to borrow the principal sum of \$48 000 secured by a charge over the general rates of the municipality, such sum to be raised by the grant of a mortgage in accordance with the provisions of the *Local Government Act 1958*.

- 1. The maximum rate of interest that may be paid is 15.8 per centum per annum.
- 2. The purpose for which the loan is to be applied is: Stage 2, Belgrave South Multi Purpose Complex \$48 000
- 3. The period of the loan shall be ten years.
- 4. The monies borrowed shall be repayable by providing out of municipal funds half-yearly instalments of approximately \$4 852.29 each including principal and interest on 1 April and 1 October during the currency of the loan.

The first instalment shall be payable on 1 April 1984.

5. Such money shall be repayable to the Commissioners of the State Bank of Victoria at the office of the said Commissioners, 385 Bourke Street, Melbourne.

The plans and specifications and the estimate of the cost of the proposed works and a statement showing the proposed expenditure of the monies to be borrowed are open for inspection at the office of the Council of the Shire of Sherbrooke, Glenfern Road, Upwey.

K. E. MATSON, General Manager and Shire Secretary

8479

SHIRE OF WALPEUP

Loan No. 53

Notice of Intention to Borrow the Sum of \$100 000.00 for Permanent Works and Undertakings.

Notice is hereby given that the Council of the Shire of Walpeup proposes to borrow the principal sum of \$100 000.00, secured by a charge over the general rates of the municipality, such sum to be raised in accordance with the provisions of the *Local Government Act 1958*.

- 1. The maximum rate of interest that may be paid is 15.9 per centum per annum.
- 2. The purpose for which loan funds are to be applied are part cost of Road Grader — \$50 000.00. Purchase and Installation of Computer and Associated Software — \$50 000.00.
- 3. The period of the Loan shall be ten (10) years.
- 4. The moneys borrowed shall be repayable by providing out of the municipal fund twenty (20) half yearly instalments of \$10 147.35 including principal and interest on 1 May and 1 November during the currency of the Loan. The first instalment shall be payable on 1 May 1984.
- 5. Such instalments shall be repayable to the Australian and New Zealand Savings Bank Limited, Oke Street, Ouyen 3490.

The plan and specifications and the estimate of the cost of the proposed works and a statement showing the proposed expenditure of the funds to be borrowed are open for inspection at the office of the Council of the Shire of Walpeup, Oke Street, Ouyen 3490.

8434

B. W. CROSS, Shire Secretary

GEELONG WATERWORKS AND SEWERAGE TRUST

Pursuant to Section 60 of the *Geelong Waterworks and Sewerage Act 1958* (No. 6263) the Trust has prepared plans to indicate the particulars of sewers and underground works, the construction of which the Trust intends to begin, at a date not less than one month after publication of the notices, in or adjacent to the following localities within the Drainage Area.

Lothian Street, North Geelong — Shire of Corio

Malvern Grove, Manifold Heights — City of Geelong West

Notice is hereby given that the plans indicated are open for public inspection at the Trust's Offices, 61-67 Ryrrie Street, Geelong between the hours of 8.10 a.m. and 5.00 p.m. from Monday to Friday (public holidays excepted) by the owners or occupiers of land or premises within the Drainage Area.

8480

R. A. JORDAN, Secretary

MARYSVILLE WATERWORKS TRUST

Notice under Section 207 of *Water Act 1958*

Notice to owners of tenements in Allison Crescent (Lots 17-24 and 31-39 inclusive as shown on LP 51957) and lots 25-27 Martin Road as shown LP 51957.

The main pipe in the said street being laid down, the owners of all tenements situated as above are hereby required on or before 31 October next to cause a proper pipe and stop cocks to be laid so as to supply water within such tenements from the main pipe.

8510

M. S. COCKERELL, Secretary

MARYSVILLE WATERWORKS TRUST

Notice under Section 207 of *Water Act 1958*

Notice to owners of tenements in Sunds Road (Lots 1-3 as shown on LP 123631).

The main pipe in the said street being laid down, the owners of all tenements as situated above are hereby required on or before 31 October next to cause a proper pipe and stop cocks to be laid so as to supply water within such tenements from the main pipe.

8511

M. S. COCKERELL, Secretary

WESTERNPORT WATERWORKS TRUST

Notice to owners of tenements in the undermentioned streets and private streets, lanes, courts and alleys opening thereto. The main pipe in the said street being laid down, the owners of all tenements situated as under are hereby required on or before 1 September 1983 to cause a proper pipe and stop cocks to be laid down so as to supply water within such tenements from the main pipe:

Woolamai Waters (West)

Woolamai Beach Road (between Lantana Road and Princeton Avenue), Lantana Road (between Woolamai Beach Road and Second Avenue), Tampa Road (between Woolamai Beach Road and Second Avenue), Ocean Reach (between Woolamai Beach Road and Second Avenue), Seesburg Street (between Woolamai Beach Road and Second Avenue), Kendall Avenue (between Woolamai Beach Road and Surfers Drive), Surfers Drive (between Woolamai Beach Road and Second Avenue), Princeton Ave. (between Woolamai Beach Road and Second Avenue), First Ave. (between Surfers Drive and Lantana Road), Second Avenue (between Princeton Avenue and Lantana Road).

Ventnor

Fisher Street and connecting through to Flinders Street.

8444

C. F. BEASLEY, Secretary

SUNBURY SEWERAGE AUTHORITY

Notice is hereby given that the above Authority intends to construct sewers and related works in the area immediately north of Gap Road and east of Anderson Street to serve the Salvation Army Complex in Anderson Road.

Maps and plans showing the works to be constructed are open for inspection at the Authority's Office, Municipal Office, Macedon Street, Sunbury, between the hours of 9.00 a.m. and 5.00 p.m., Monday to Friday.

8512

JOHN M. KELLY, Secretary

HEYTESBURY SEWERAGE AUTHORITY

Sewerage Area General Notice

The Heytesbury Sewerage Authority, having made provision for the removal of sewerage for each and every property which or any part of which, is within the sewerage area hereinafter described, hereby declares that on or after 1 October 1983 each and every property, all or any part of which is in the said sewerage area, shall be deemed to be a sewerage property within the meaning of the Sewerage Districts Act of 1958.

Sewerage Area No. 11

The land described as being in the above Sewerage Area is all located in the Cobden Township, Parish of Tandarook being more particularly designated as:

1. Part Crown Allotment 10, Section 29, Mitchell Street
2. South west portion of the Cobden Recreation Reserve and being the area on which the toilet blocks, changerooms and social clubrooms are situated
3. Lots 1 to 7 inclusive L/P 8353, Lots 1 and 2 L/P 93225, Lot 53 L/P 3800, and Part Crown Allotment F2, all situated in Cemetery Road
4. Lots 23 and 24 L/P 4891 Cobden-Stoneyford Road

These areas are shown on a plan which may be inspected at the Authority's Office, Municipal Offices, Cobden.

By order of the Authority

J. S. BLAKE, Chairman
M. L. WHELAN, Secretary

FRANKSTON SEWERAGE AUTHORITY

Commencement of Works

Notice is hereby given that the Authority intends to construct sewers in the following general areas:

- (i) Seaford Road, Frankston/Dandenong Road, Mad-den Street, Stephen Street and Apsley Place, Seaford.
- (ii) Klauer Street, Frankston/Dandenong Road, Braemer Street, Hadley Street, Quinn Street, Frankston.
- (iii) Maple Street, Cane Avenue, East Road, Seaford.

Details of the proposed works are available for inspection at the office of the Authority, Civic Centre Annexe, 34 Davey Street, Frankston between 8.45 a.m. to 4.30 p.m., Tuesday to Friday and 8.45 a.m. to 8.00 p.m. Monday.

8435

A. H. BUTLER, Secretary

DROMANA-ROSEBUD SEWERAGE AUTHORITY**Notice of intention to commence works**

The Dromana-Rosebud Sewerage Authority advise that sewer construction works will soon be carried out in the following areas.

Clacton Estate — Stage 1 — Rosebud

Comprises the construction of sewers to serve properties included in the Shire of Flinders rate recovery sales and adjoining properties, as follows:

- Nos. 129 to 147 First Avenue, Rosebud
- Nos. 120 to 150 Second Avenue, Rosebud
- Nos. 290 to 300 Eastbourne Road, Rosebud
- Nos. 141 to 147 Seventh Avenue, Rosebud
- Nos. 142 to 152 Eighth Avenue, Rosebud

Sewer Reticulation Stage 5F

Comprising approximately 110 properties located south of Boundary Road in Dromana.

The area is bounded on the north side by Boundary Road; on the east side by Manna Street, on the south side by Seaview Street and extends westward to the limit of existing residential development.

Sewer Reticulation Stage 5G

Comprising approximately 190 properties located south of Boundary Road, Dromana.

The area is bounded on the north side by Boundary Road, on the east side by Gracefield Avenue and Dorothy Crescent; on the west side by Caldwell Street and extends southward to the limit of existing residential development.

Sewer Reticulation Stage 6C

Comprising approximately 170 properties located south of the Peninsula Freeway, Dromana.

The area is bounded on the north side by Palmerston Avenue, on the east side by Lugano and Lombardy Avenues, and on the west side by Pine, Aster, Begonia, Boronia and Cosmos Streets.

Any interested person may inspect the plan of works at the Office of the Authority, Nepean Highway, Dromana between 9.00 a.m. and 4.00 p.m., Monday to Friday.

8463 J. O. WILLIAMS, Secretary

NOTICE OF CHANGE OF SURNAME

I, Janette Ann Newman of 19 Phillack Crescent, Rawson in the State of Victoria, heretofore called and known by the name of Janette Ann Wright, hereby give notice that on 17 August 1983, I renounced and abandoned the use of my said Surname of Wright and assumed in lieu thereof the Surname of Newman.

And further such change of name is evidenced by a Deed dated 17 August 1983, duly executed by me and attested and filed in the Office of the Registrar General

Dated 19 August 1983

8481 JANETTE ANN NEWMAN late WRIGHT

Form 1**SECOND SCHEDULE****Notice of Application for a Licence to divert water from the King River at Whitfield, Allotment 16, Parish of Whitfield**

I hereby give notice of an application for a licence empowering me to divert water for a term of 15 years to the extent of 27 megalitres per annum at a maximum rate of two megalitres per day of 24 hours for the irrigation of six hectares of grape vines and to occupy certain Crown lands for diversion works.

Any objection to the granting of this application must be forwarded in writing to reach the State Rivers and Water Supply Commission, 590 Orrong Road, Armadale 3143, before 12 September 1983, being 30 days from the publication of this notice.

8436 HARRY GUY DARLING, Koombahla, Whitfield

ACT 391 — FIRST SCHEDULE

I, John Hazlewood, of 49 Lydiard Street South, Ballarat, head or authorized representative of the denomination known as St. John's Rectory with the consent of Ballarat Diocesan Trustees, of 49 Lydiard Street South, Ballarat, trustees of the land described in the subjoined statement of trusts, and of Denys Tonks of St. John's Rectory being the person entitled to minister in or occupy a building or buildings upon the said land, hereby apply to the Governor of the State of Victoria for leave to dispose of the said land by means and for the purposes mentioned in the said statement of trusts and I hereby certify that the said land was reserved by Order in Council on 12 August 1861 for the purpose of Church of England purposes.

That the only trustees of the said land resident in the State of Victoria are Ballarat Diocesan Trustees.

That the only buildings upon the said land are church, rectory, hall, kindergarten and toilets and that the only person entitled to minister in or occupy the same is the abovenamed Denys Tonks.

Signed by the said John Hazlewood in the presence of P. Rowlands.

J. HAZLEWOOD

We consent to this application.

The Common Seal of the Ballarat Diocesan Trustees was affixed hereto in the presence of us being three of the Trustees authorised to attest the affixing of such seal.

(SEAL) JAMES A. BATCH, Trustee
GRAHAM H. WALDEN, Trustee
P. ROWLANDS, Trustee

Signed by the said Denys Tonks in the presence of P. Rowlands.

DENYS TONKS

Statement of Trusts

Description of Land: 3035 square metres, Township of Ballarat, Parish of Ballarat, County of Grenville being Crown Allotment 16, Section X.

Commencing at the south-western angle of Crown Allotment 17, Section X; bounded thence by that allotment bearing 90° 00' 50-29 metres: by allotment 1, 10 and 11 bearing 180° 00' 60-35 metres: by allotments 14 and 15A bearing 270° 00' 50-29 metres; and thence by Armstrong Street bearing 0° 00' 60-35 metres to the point of commencement.

Name of Trustees: Ballarat Diocesan Trustees of 49 Lydiard Street South, Ballarat.

Powers of Disposition: To permit and suffer so much of the land as shall not be disposed of under the powers hereinafter specified to be used for the purposes for which it was promised or permanently reserved from sale by the Crown. To let lease self mortgage or exchange if concurred in by the said Head or Authorized Representative for the time being, the said land or any portion thereof or any buildings thereon on such terms and conditions as shall be specified by such Head or Representative.

Purposes to which Proceeds of Disposition are to be applied: Money obtained from sales leases mortgages or exchanges to be paid to the Bishop to be dealt with for Church of England purposes as shall be directed by the said Trustees but to be sub-

ject nevertheless to the payment or deduction therefrom of all costs charges and expenses incurred by the Trustee or for which it shall be liable in respect of the trust estate.

8445

Notice is hereby given that the partnership heretofore subsisting between Fiore Cari and Joseph Anthony Care, carrying on business as Video Equipment Retailers and Hirers at Shop 6, Shepparton Safeway Plaza, Benalla Road, Shepparton, under the style or firm name of Plaza Video, has been dissolved as from 17 August 1983. The said business will continue to be carried on under the style or firm name of Plaza Video by the said Fiore Cari of 7 Bradford Road, Shepparton who shall be entitled to all monies due to the said business and responsible for all the debts of the said business.

Dated 17 August 1983

Signed by the said Fiore Cari in the presence of Peter C. Johnson.

Signed by the said Joseph Anthony Care in the presence of Peter C. Johnson.

8513

NOTICE OF RETIREMENT AND ADMISSION OF PARTNERS

Notice is hereby given that the partnership heretofore subsisting between Peter Barry Morgan, Kerry Vincent Morgan, Theo Van Den Berg and Maxwell John Hewitt, carrying on business under the style or firm name of Corio Bay Clay Target Range, has been dissolved as from 13 May 1983 so far as concerns the said Kerry Vincent Morgan, Theo Van Den Berg and Maxwell John Hewitt, who all have retired from the said firm and notice is hereby given that Kathleen Margaret Morgan and Laurence Anthony Morgan have purchased the interests of the retiring partners and have been admitted to the partners in the firm, and the said partnership will be continued under the style and firm name of Corio Bay Clay Target Range as from 13 May 1983.

Dated 13 May 1983

PETER BARRY MORGAN
KERRY VINCENT MORGAN
THEO VAN DEN BERG
MAXWELL JOHN HEWITT
KATHLEEN MARGARET MORGAN
LAURENCE ANTHONY MORGAN

8482

Notice is hereby given that the Partnership hereto subsisting between Ralph Frederick Ludeman of Kamarooka in the State of Victoria, farmer, and Kenneth Henry Ludeman of Kamarooka in the State of Victoria, farmer, carrying on business as Farmers at Kamarooka under the name of R. F. & K. H. Ludeman has been dissolved as from 1 April 1983.

Dated 15 April 1983

8450

Notice is hereby given that the Partnership subsisting between William A. Koppel, Angella M. Zugan, Predrag Cvek and Constantinos Arvanitis carrying on the business known as Transtime at 17 Hedgley Road, Noble Park, has been dissolved as from 19 July 1983, and further take notice that as of the said 19 July 1983 William A. Koppel, Angella M. Zugan and

Predrag Cvek will no longer be responsible for any debts incurred or liabilities incurred on behalf of Transtime or Constantinos Arvanitis.

Dated 17 August 1983

WILLIAM A. KOPPEL
ANGELLA M. ZUGAN
PREDRAG CVEK
CONSTANTINOS ARVANITIS

8451

Take notice that the partnership conducted by Murray McPhee Dyer, Maree Joy Dyer, Douglas Clifford Harry and Kay Rosemary Harry trading a "Mallee Burger" has been dissolved as from 1st May, 1983. The aforesaid Murray McPhee Dyer and Maree Joy Dyer shall continue to trade as "Mallee Burger" as joint proprietors.

8464

Companies (Victoria) Code

INSULROOF MANAGEMENT PTY. LTD.

Notice is hereby given that a Petition for the winding up of the above Company by the Supreme Court was on the 16 August 1983 presented by David Brian Jackson and Lesley Ann Jackson.

And that the said Petition is directed to be heard before the Court sitting at Melbourne at the hour of 10.30 o'clock in the forenoon on Thursday 6 October 1983 and any creditor or contributory of the Company desiring to support or oppose the making of an Order on the said Petition may appear at the time of hearing by himself or his counsel for that purpose and a copy of the Petition will be furnished to any creditor or contributory of the said Company requiring the same by the undersigned on payment of the regulated charge for the same.

The Petitioner's address is 4 Ajana Lane, Frankston.

The Petitioner's solicitors are Messrs. Remington & Co., of 2nd Floor, 60 Albert Road, South Melbourne.

Note — Any persons who intend to appear on the hearing of the said Petition must serve on or send by post to the above-named Solicitors a notice in writing of this intention so to do. The notice must state the name and address of the firm, and must be signed by the person or firm, or his or their solicitor (if any), and must be served, or, if posted, must be sent by post in sufficient time to reach the abovenamed not later than 4 o'clock in the afternoon of 5 October 1983.

8465

Companies (Victoria) Code

386 INKERMAN STREET PTY. LTD. (IN VOLUNTARY LIQUIDATION)

Notice is hereby given that pursuant to Section 411 of the Companies (Victoria) Code final meetings of the members of the abovenamed Company will be held at 7 Matlock Court, Caulfield on Friday 30 September 1983 at 2.00 p.m.

Business: To receive the Liquidator's Accounts.

8466

In the Supreme Court of Victoria, C.O. 13133 — In the matter of the Companies (Victoria) Code; and in the matter of Gilbert & Jones Pty. Ltd.

Notice is hereby given that on 28 April 1983 an Order of the Supreme Court was made and that Robert Eastaugh Ramsay of 5th Floor, 400 Little Collins Street, Melbourne, was appointed Provisional Liquidator.

MESSRS. MACPHERSON & KELLY, solicitors, 8th Floor, 416-420 Collins Street, Melbourne, solicitors for the Petitioner

8518

In the Supreme Court of Victoria, C.O. 13137 — In the matter of the Companies (Victoria) Code; and in the matter of W.F. Montague Coolstores Pty. Ltd.

Notice is hereby given that on 22 June 1983, an Order of the Supreme Court was made and that Robert Eastaugh Ramsay of 5th Floor, 400 Collins Street, Melbourne was appointed Provisional Liquidator.

MESSRS. MACPHERSON & KELLY, solicitors, 8th Floor, 416-420 Collins Street, Melbourne, solicitors for the Petitioner 8519

In the Supreme Court of Victoria, C.O. 13204 — In the matter of the Companies (Victoria) Code; and in the matter of Linmasace Pty. Ltd.

Notice is hereby given that on 31 May 1983, an Order of the Supreme Court was made and that Robert Eastaugh Ramsay of 5th Floor, 400 Collins Street, Melbourne was appointed Provisional Liquidator.

MESSRS. MACPHERSON & KELLY, solicitors, 8th Floor, 416-420 Collins Street, Melbourne, solicitors for the Petitioner 8520

Companies (Victoria) Code

Companies Form 96 — Section 370 (1) (b)

Registered No. C 104082

O.P. DANISH CAKE COMPANY PTY. LTD.

Notice of Winding-up Order

On 28 July 1983 the Supreme Court made an order that the Company be wound up by the Court and appointed me to be Liquidator.

ROBERT ARTHUR WATER, Liquidator

CORNWALL STODART & CO., solicitors for the Applicant. 8514

Notice of Winding-up Order

In the matter of Cardio-Rhythmics Pty. Limited

Winding-up Order: Made 18 August 1983.

Ian Kenneth McKinnon of 576 St. Kilda Road, Melbourne has been appointed Liquidator.

Dated 22 August 1983

PHILLIPS, FOX & MASEL, solicitor for the Applicant 8500

Companies Act 1961

Section 272 (2)

MODULAR TRANSPORT AUSTRALIA PTY. LTD.

(IN LIQUIDATION)

Notice of Final Meeting

Notice is hereby given pursuant to Section 272 (1) of the Companies Act 1961, a general meeting of members and creditors of Modular Transport Australia Pty. Ltd. will be held in the Boardroom, Pannell Kerr Forster, Chartered Accountants, Level 14, 500 Bourke Street, Melbourne on 30 September 1983 at 10.30 a.m. in the forenoon.

The purpose of the meeting is to lay accounts before it showing the manner in which the winding up has been conducted and the property of the company has been disposed of and of hearing any explanation that may be given by the Liquidator. Dated 18 August 1983

P. R. VINE, Liquidator

PANNELL KERR FORSTER, Level 14, 500 Bourke Street, Melbourne, 3000. 8501

In the matter of the Companies Act 1961 and in the matter of Dawste Pty. Ltd. (In Liquidation)

Notice of Final Meeting of Members pursuant to Section 272 and Notice to Creditors to Lodge Claims

Notice is hereby given in pursuance of Section 272 of the Companies Act 1961 that a General Meeting of the members of the above company will be held at the office of Messrs. Coopers & Lybrand, 11th Floor, 460 Bourke Street, Melbourne on 26 September 1983 at 10.30 in the forenoon for the purpose of having an account laid before them showing the manner in which the winding up has been conducted and the property of the company disposed of, and hearing any explanation that may be given by the Liquidator.

Notice is also given that any creditors who have claims which have not yet been satisfied must lodge such claims with me prior to 31 August 1983 or be excluded from settlement.

Dated 24 August 1983

A. N. BIRD, Liquidator

COOPERS & LYBRAND, chartered accountants, 11th Floor, 460 Bourke Street, Melbourne, Vic. 3000. 8502

In the matter of the Companies Act 1961 and in the matter of Kebros Pty. Ltd. (In Liquidation)

Notice of Final Meeting of Members pursuant to Section 272 and Notice to Creditors to Lodge Claims

Notice is hereby given in pursuance of Section 272 of the Companies Act 1961 that a General Meeting of the members of the above company will be held at the office of Messrs. Coopers & Lybrand, 11th Floor, 460 Bourke Street, Melbourne on 26 September 1983 at 10.00 o'clock in the forenoon for the purpose of having an account laid before them showing the manner in which the winding up has been conducted and the property of the company disposed of, and hearing any explanation that may be given by the Liquidator.

Notice is also given that any creditors who have claims which have not yet been satisfied must lodge such claims with me prior to 31 August 1983 or be excluded from settlement.

Dated 24 August 1983

A. N. BIRD, Liquidator

COOPERS & LYBRAND, chartered accountants, 11th Floor, 460 Bourke Street, Melbourne, Vic. 3000. 8503

In the Supreme Court of Victoria, C.O. 13269 — In the matter of the Companies (Victoria) Code; and in the matter of Temjad Holdings Pty. Ltd.

Notice is hereby given that on 23 June 1983 an Order of the Supreme Court was made and that Robert Eastaugh Ramsay of 5th Floor, 400 Little Collins Street, Melbourne, was appointed Provisional Liquidator.

MESSRS. MACPHERSON & KELLEY, solicitors, 8th Floor, 416-420 Collins Street, Melbourne, solicitors for the Petitioner 8525

In the Supreme Court of Victoria, C.O. 13272 — In the matter of the Companies (Victoria) Code; and in the matter of Cyborg Corporation (Aust.) Pty. Ltd.

Notice is hereby given that on 23 June 1983 an Order of the Supreme Court was made and that Robert Eastaugh Ramsay of 5th Floor, 400 Little Collins Street, Melbourne, was appointed Provisional Liquidator.

MESSRS. MACPHERSON & KELLEY, solicitors, 8th Floor, 416-420 Collins Street, Melbourne, solicitors for the Petitioner 8526

In the Supreme Court of Victoria, C.O. 13271 — In the matter of the Companies (Victoria) Code; and in the matter of Astrodyn Corporation (Aust.) Pty. Ltd.

Notice is hereby given that on 23 June 1983 an Order of the Supreme Court was made and that Robert Eastaugh Ramsay of 5th Floor, 400 Little Collins Street, Melbourne, was appointed Provisional Liquidator.

MESSRS. MACPHERSON & KELLEY, solicitors, 8th Floor, 416-420 Collins Street, Melbourne, solicitors for the Petitioner 8527

In the Supreme Court of Victoria, C.O. 13270 — In the matter of the Companies (Victoria) Code; and in the matter of Analytics Corporation (Aust.) Pty. Ltd.

Notice is hereby given that on 23 June 1983 an Order of the Supreme Court was made and that Robert Eastaugh Ramsay of 5th Floor, 400 Little Collins Street, Melbourne, was appointed Provisional Liquidator.

MESSRS. MACPHERSON & KELLEY, solicitors, 8th Floor, 416-420 Collins Street, Melbourne, solicitors for the Petitioner 8528

In the Supreme Court of Victoria, C.O. 13340 — In the matter of the Companies (Victoria) Code; and in the matter of Computer Country Pty. Ltd.

Notice is hereby given that a Petition for the winding-up of the abovenamed company by the Supreme Court was on 29 July 1983 presented by Eric John Unger, Deputy Commissioner of Taxation of the Commonwealth of Australia and that the said Petition is directed to be heard before the Court sitting at the Fifteenth Court, Law Courts, Lonsdale Street, Melbourne at the hour of 10.30 o'clock in the forenoon on 6 October 1983 and any creditor or contributory of the said company desiring to support or oppose the making of an order on the said Petition may appear at the time of hearing by himself or his counsel for that purpose; and a copy of the Petition will be furnished to any creditor or contributory of the said company requiring the same by the undersigned on payment of the regulated charge for the same.

The Petitioners' official address is 350 Collins Street, Melbourne.

The Petitioners' solicitor is B. J. O'Donovan, Crown Solicitor for the Commonwealth of 200 Queen Street, Melbourne.

B. J. O'DONOVAN

Note — Any person who intends to appear on the hearing of the said Petition must serve on or send by post to the abovenamed B. J. O'Donovan notice in writing of his intention to do so. The notice must state the name and address of the person, or, if a firm, the name and address of the firm, and must be signed by the person or firm, or his or their solicitor (if any), and must be served, or, if posted, must be sent by post in sufficient time to reach the abovenamed not later than 4.00 in the afternoon of 5 October 1983 8534

In the Supreme Court of Victoria, C.O. 13246 — In the matter of the Companies (Victoria) Code; and in the matter of R.E.V. Transport Pty. Ltd.

Notice of Winding-up Order

Winding-up Order: Made 18 August 1983.

Name and address of Liquidator: E. H. Niemann, C/- Messrs. Hungerford, Hancock & Offner, 80 Collins Street, Melbourne, 3000.

HOME, WILKINSON & LOWRY, solicitors for the Petitioner 8535

In the Supreme Court of Victoria, C.O. 13354 — In the matter of the Companies (Victoria) Code; and in the matter of Argyle Engineering Pty. Ltd.

Notice is hereby given that an application for the winding up of the abovenamed company by the Supreme Court was on 10 August 1983 presented by Lucar Pty. Ltd. (In Liquidation) and that the said application is directed to be heard before the Court sitting at the Practice Court, Law Courts, Lonsdale Street, Melbourne at the hour of 10.30 o'clock in the forenoon on 29 September 1983; and any creditor or contributory of the said company desiring to support or oppose the making of an order on the said application may appear at the time of hearing by himself or his counsel for the purpose; and a copy of the said application will be furnished to any creditor or contributory of the said company requiring the same by the undersigned on payment of the regulated charge for the same.

The Applicant's full address is c/- the office of the Liquidator, Warwick Allen Leeming of the office of Duesburys, Chartered Accountants, 114 William Street, Melbourne.

The Applicant's Solicitors are Messrs. Weigall & Crowther of 12th Floor, 459 Little Collins Street, Melbourne.

WEIGALL & CROWTHER, solicitors for the Applicant.

Note — Any person who intends to appear on the hearing of the said application must serve on or send by post to the abovenamed Messrs. Weigall & Crowther, notice in writing of his intention so to do. The notice must state the name and address of the person, or, if a firm, the name and address of the firm, and must be signed by the person or firm, or his, or their solicitors (if any) and must be served, or, if posted, must be sent by post in sufficient time to reach the abovenamed not later than four o'clock in the afternoon of 28 September 1983. 8493

In the Supreme Court of Victoria, C.O. 13357 — In the matter of the Companies (Victoria) Code; and in the matter of Waco Trading Pty. Ltd.

Notice is hereby given that an application for the winding up of the abovenamed company by the Supreme Court was on 10 August 1983 presented by Lucar Pty. Ltd. (In Liquidation) and that the said application is directed to be heard before the Court sitting at the Practice Court, Law Courts, Lonsdale Street, Melbourne at the hour of 10.30 o'clock in the forenoon on 29 September 1983; and any creditor or contributory of the said company desiring to support or oppose the making of an order on the said application may appear at the time of hearing by himself or his counsel for the purpose; and a copy of the said application will be furnished to any creditor or contributory of the said company requiring the same by the undersigned on payment of the regulated charge for the same.

The Applicant's full address is c/- the office of the Liquidator, Warwick Allen Leeming of the office of Duesburys, Chartered Accountants, 114 William Street, Melbourne.

The Applicant's Solicitors are Messrs. Weigall & Crowther of 12th Floor, 459 Little Collins Street, Melbourne.

WEIGALL & CROWTHER, solicitors for the Applicant.

Note — Any person who intends to appear on the hearing of the said application must serve on or send by post to the abovenamed Messrs. Weigall & Crowther, notice in writing of his intention so to do. The notice must state the name and address of the person, or, if a firm, the name and address of the firm, and must be signed by the person or firm, or his, or their solicitors (if any) and must be served, or, if posted, must be sent by post in sufficient time to reach the abovenamed not later than four o'clock in the afternoon of 28 September 1983. 8494

In the Supreme Court of Victoria, Company Number C-157316-X — In the matter of the Companies (Victoria) Code; and in the matter of Bristowe and Davidson Pty. Ltd.

Notice is hereby given that a Petition for the winding up of the abovenamed company by the Supreme Court was on 31 May 1983 presented by Patricia Anne Bristowe and that the said Petition is directed to be heard before the Court sitting at Melbourne at the hour of 10.30 a.m. on 8 September 1983 and any creditor or contributory of the said company desiring to support or oppose the making of an order on the said Petition may appear at the time of hearing by himself or his counsel for that purpose and a copy of the Petition will be furnished to any creditor or contributory of the said company requiring the same by the undersigned on payment of the regulated charge for the same.

The Petitioner's address is 901 Geelong Road, Mount Clear, Victoria.

The Petitioner's solicitors are Messrs. Molomby & Molomby of 459 Collins Street, Melbourne as Town Agents for Messrs. Pirie & Sutton, solicitors of 17 Doveton Street North, Ballarat.

Note — Any person who intends to appear on the hearing of the said Petition must serve on or send by post to the abovenamed Petitioner or solicitors notice in writing of his intention so to do. The notice must state the name and address of the person, or, if a firm, the name and address of the firm, and must be signed by the person or firm, or his or their solicitor (if any), and must be served, or, if posted, must be sent by post in sufficient time to reach the abovenamed not later than 4.00 o'clock in the afternoon on 7 September 1983 (the day before the day appointed for the hearing of the Petition or the Friday preceding the day appointed for hearing of the Petition if such day is a Monday or Tuesday following a public holiday). 8483

In the Supreme Court of Victoria, C.O. 13205 — In the matter of the Companies (Victoria) Code; and in the matter of A. W. Dark Pty. Ltd.

Notice is hereby given that a Petition for the winding up of the abovenamed company by the Supreme Court was on 31 May 1983 presented by William Robert Hood, Ida Florence Dark and Hedera Helena Nominees Pty. Ltd., and that the said Petition is directed to be heard before the Court sitting at Melbourne at the hour of 10.30 a.m. on 7 September 1983 and any creditor or contributory of the said company desiring to support or oppose the making of an order on the said Petition may appear at the time of hearing by himself or his counsel for that purpose and a copy of the Petition will be furnished to any creditor or contributory of the said company requiring the same by the undersigned on payment of the regulated charge for the same.

The Petitioner's addresses are William Robert Hood of 21 Wattle Drive, Frankston 3199, Ida Florence Dark of 2941 Nepean Highway, Rye 3941, Hedera Helena Nominees Pty. Ltd., 6 Spring Road, Caulfield 3162.

The Petitioner's solicitors are Messrs. Macpherson & Kelley, 8th Floor, 416-420 Collins Street, Melbourne, Vic., 3000.

Note — Any person who intends to appear on the hearing of the said Petition must serve on or send by post to the abovenamed Petitioner or solicitors notice in writing of his intention so to do. The notice must state the name and address of the person, or, if a firm, the name and address of the firm, and must be signed by the person or firm, or his or their solicitor (if any), and must be served, or, if posted, must be sent by post in sufficient time to reach the abovenamed not later than 4.00 o'clock in the afternoon on 6 September 1983 (the day before the day appointed for the hearing of the Petition or the Friday preceding the day appointed for hearing of the Petition if such day is a Monday or Tuesday following a public holiday). 8487

In the Supreme Court of Victoria, C.O. 13205 — In the matter of the Companies (Victoria) Code; and in the matter of A. W. Dark Pty. Ltd.

Notice is hereby given that on 31 May 1983 an Order of the Supreme Court was made and that Robert Eastaugh Ramsay of 5th Floor, 400 Little Collins Street, Melbourne, was appointed Provisional Liquidator.

MESSRS. MACPHERSON & KELLEY, solicitors, 8th Floor, 416-420 Collins Street, Melbourne, solicitors for the Petitioner 8521

In the Supreme Court of Victoria, C.O. 13278 — In the matter of the Companies (Victoria) Code; and in the matter of Sadiok Pty. Ltd.

Notice is hereby given that on 24 July 1983, an Order of the Supreme Court was made and that Robert Eastaugh Ramsay of 5th Floor, 400 Collins Street, Melbourne was appointed Provisional Liquidator.

MESSRS. MACPHERSON & KELLEY, solicitors, 8th Floor, 416-420 Collins Street, Melbourne, solicitors for the Petitioner 8522

In the Supreme Court of Victoria, C.O. 13277 — In the matter of the Companies (Victoria) Code; and in the matter of Respanra Pty. Ltd.

Notice is hereby given that on 27 June 1983, an Order of the Supreme Court was made and that Robert Eastaugh Ramsay of 5th Floor, 400 Collins Street, Melbourne was appointed Provisional Liquidator.

MESSRS. MACPHERSON & KELLEY, solicitors, 8th Floor, 416-420 Collins Street, Melbourne, solicitors for the Petitioner 8523

In the Supreme Court of Victoria, C.O. 13254 — In the matter of Gasbourne Pty. Ltd.

Notice is hereby given that on 16 June 1983, an Order of the Supreme Court was made and that Robert Eastaugh Ramsay of 5th Floor, 400 Collins Street, Melbourne was appointed Provisional Liquidator.

MESSRS. MACPHERSON & KELLEY, solicitors, 8th Floor, 416-420 Collins Street, Melbourne, solicitors for the Petitioner 8524

In the Supreme Court of Victoria 1983, C.O. 13380 — In the matter of the Companies (Victoria) Code; and in the matter of Moe City Reporter Pty. Ltd.

Notice of Appointment of Provisional Liquidator

Order for the appointment of an Official Liquidator as Provisional Liquidator made Friday, 19 August 1983.

Name and address of the Provisional Liquidator: Alex Neville Bird, 11th Floor, 499 St. Kilda Road, Melbourne. 8498

Notice of Winding-up Order

In the matter of Bishopsgate Insurance Australia Ltd. (in Provisional Liquidation)

Winding-Up Order: Made 18 August 1983.

Name and address of Liquidator: Warwick Allen Leeming, of Messrs. Duesburys, Chartered Accountants, 114 William Street, Melbourne.

ELLISON HEWISON & WHITEHEAD, solicitors for the applicant 8499

In the Supreme Court of Victoria, C.O. 13380 — In the matter of the Companies (Victoria) Code; and in the matter of Moe City Reporter Pty. Ltd.

Notice is hereby given that an application by way of Petition for the winding up of the abovenamed company by the Supreme Court was on 19 August 1983 presented by Latrobe Valley Express Proprietary Limited and that the Petition is directed to be heard before the Court sitting at the Practice Court, Law Courts, Lonsdale Street, Melbourne at the hour of 10.30 a.m. on Thursday, 13 October 1983; and any creditor or contributory of the said company desiring to support or oppose the making of an order on the said Petition may appear at the time of hearing by himself or his counsel for that purpose; and a copy of the Petition will be furnished to any creditor or contributory of the said company requiring the same by the undersigned on payment of the regulated charge for the same.

The Petitioner's address is 21 George Street, Morwell.

The Petitioner's Solicitor is Philip E. Fox, Esq., of 23rd Floor, 367 Collins Street, Melbourne as Melbourne agents for Messrs. Ryan, Verhoeven & Horseman, 17-19 George Street, Morwell.

Note — Any person who intends to appear on the hearing of the said Petition must serve on or send by post to the abovenamed solicitor notice in writing of his intention so to do. The notice must state the name and address of the person, or if a firm, the name and address of the firm and must be signed by the person or firm or his or their solicitors (if any) and must be served, or, if posted, must be sent by post in sufficient time to reach the abovenamed solicitor not later than four o'clock in the afternoon of 12 October 1983. 8497

In the Supreme Court of Victoria, C.O. 13373 — In the matter of the Companies (Victoria) Code; and in the matter of P. & W. Trading Pty. Ltd.

Notice is hereby given that a petition for the winding up of the abovenamed company by the Supreme Court was on 16 August 1983 presented by Burton Cables Pty. Ltd. of 456 Victoria Street, Brunswick in the State of Victoria and that the said petition is directed to be heard before the Court sitting at Melbourne, at the hour of 10.30 o'clock in the forenoon on Thursday, 6 October 1983 and any creditor or contributory of the said company desiring to support or oppose the making of an order on the said petition may appear at the time of hearing by himself or his counsel for that purpose; and a copy of the petition will be furnished to any creditor or contributory of the said company requiring the same by the undersigned on payment of the regulated charge for the same.

The Petitioner's address is care of Thomas H. Bell & Co., Solicitors, 552 Lonsdale Street, Melbourne.

The Petitioner's Solicitors are Thomas H. Bell & Co., 552 Lonsdale Street, Melbourne.

THOMAS H. BELL & CO., solicitors for the said Burton Cables Pty. Ltd.

Note — Any person who intends to appear on the hearing of the said petition must serve on or send by post to the abovenamed Solicitors notice in writing of his intention so to do. The notice must state the name and address of the person, or, if a firm, the name and address of the firm, and must be signed by the person or firm, or his or their solicitors (if any), and must be served, or, if posted, must be sent in sufficient time to reach the abovenamed not later than 4.00 o'clock in the afternoon on 5 September 1983. 8492

DAYLESFORD (NO. 1) CO-OPERATIVE HOUSING SOCIETY LIMITED

Special Resolution

Passed 11 August 1983.

At a special general meeting of the abovenamed society duly convened and held at 12 Albert Street, Daylesford on 11 August 1983, the subjoined special resolution was duly passed:

That the Society having successfully completed its objectives 45 months ahead of its expected term be wound up voluntarily, and that Frederick John Evans of Tessiers Road, Daylesford, be appointed liquidator for the purposes of the winding up.

J. T. WALKER, Chairman of Meeting

8490 F. J. EVANS, Secretary

In the Supreme Court of Victoria, C.O. 13363 — In the matter of the Companies (Victoria) Code; and in the matter of Elliott & Kendall Electrical Services Pty. Ltd.

Notice is hereby given that an application for the winding up of the abovenamed company by the Supreme Court was on 11 August 1983 presented by Kentfield Enterprises Pty. Ltd. and that the said application is directed to be heard before the Court sitting at the Fifteenth Court, Law Courts, Lonsdale Street, Melbourne, at the hour of 10.30 o'clock in the forenoon on 6 October 1983 and any creditor or contributory of the said company desiring to support or oppose the making of an order on the said application may appear at the time of hearing by himself or his counsel for that purpose; and a copy of the said application will be furnished to any creditor or contributory of the said company requiring the same by the undersigned on payment of the regulated charge for the same.

The Applicant's official address is 7th Floor, 128 Exhibition street, Melbourne.

The Applicant's Solicitors are Messrs. Cooke & Cussen of 128 Exhibition Street, Melbourne.

COOKE & CUSSEN, solicitors for the applicant.

Note — Any person who intends to appear on the hearing of the said application must serve on or send by post to the abovenamed Cooke & Cussen notice in writing of his intention so to do. The notice must state the name and address of the person, or, if a firm, the name and address of the firm, and must be signed by the person or firm, or his or their solicitors (if any), and must be served, or, if posted, must be sent by post in sufficient time to reach the abovenamed not later than 4.00 o'clock in the afternoon of 5 October 1983. 8491

Companies Act 1961

Section 272

WINDOW COVERINGS PTY. LTD. (IN LIQUIDATION)

Notice of Final Meeting of Creditors and Members

Notice is hereby given that a meeting of the creditors and members of Window Coverings Pty. Limited (In Liquidation) will be held at the offices of Ernst & Whinney, Level 32, 35 Collins Street, Melbourne, Victoria, 20 September 1983 at 2.00 p.m.

Agenda

To lay before the meeting the liquidator's account showing how the winding up has been conducted and the property of the company has been disposed of, and to give any explanation of the account which may be required.

Dated 22 August 1983

8441

D. O. OLDFIELD, Liquidator

In the Supreme Court of Victoria, C.O. 13133 — In the matter of the Companies (Victoria) Code; and in the matter of Gilbert & Jones Pty. Ltd.

Notice is hereby given that a petition for the winding up of the abovenamed company by the Supreme Court was on 27 April 1983 presented by Edward John Jones and Shirley May Jones and that the said petition is directed to be heard before the Court sitting at Melbourne, at the hour of 10.30 a.m. on 7 September 1983 and any creditor or contributory of the said company desiring to support or oppose the making of an order on the said petition may appear at the time of hearing by himself or his counsel for that purpose and a copy of the petition will be furnished to any creditor or contributory of the said company requiring the same by the undersigned on payment of the regulated charge for the same.

The Petitioners' address is 6 Como Street, Malvern, 3144.

The Petitioners' solicitors are Messrs. Macpherson & Kelley, 8th Floor, 416-420 Collins Street, Melbourne, Vic. 3000.

MACPHERSON & KELLEY, solicitors for the petitioner.

Note — Any person who intends to appear on the hearing of the said petition must serve on or send by post to the abovenamed Petitioner or Solicitors notice in writing of his intention so to do. The notice must state the name and address of the person, or, if a firm, the name and address of the firm, and must be signed by the person or firm, or his or their solicitor (if any), and must be served, or, if posted, must be sent by post in sufficient time to reach the abovenamed not later than 4.00 o'clock in the afternoon on 6 September 1983 (the day before the day appointed for the hearing of the petition or the Friday preceding the day appointed for the hearing of the petition if such day is a Monday or a Tuesday following a public holiday). 8488

In the Supreme Court of Victoria, C.O. 13204 — In the matter of the Companies (Victoria) Code; and in the matter of Linmasace Pty. Ltd.

Notice is hereby given that a petition for the winding up of the abovenamed company by the Supreme Court was on 31 May 1983 presented by Dinez Nominees Pty. Ltd. and that the said petition is directed to be heard before the Court sitting at Melbourne, at the hour of 10.30 a.m. on 7 September 1983 and any creditor or contributory of the said company desiring to support or oppose the making of an order on the said petition may appear at the time of hearing by himself or his counsel for that purpose and a copy of the petition will be furnished to any creditor or contributory of the said company requiring the same by the undersigned on payment of the regulated charge for the same.

The Petitioners' address is at the offices of Messrs. Moules, 28th Floor, 140 William Street, Melbourne, 3000.

The Petitioners' solicitors are Messrs. Macpherson & Kelley, 8th Floor, 416-420 Collins Street, Melbourne, Vic. 3000.

MACPHERSON & KELLEY, solicitors for the petitioner.

Note — Any person who intends to appear on the hearing of the said petition must serve on or send by post to the abovenamed Petitioner or Solicitors notice in writing of his intention so to do. The notice must state the name and address of the person, or, if a firm, the name and address of the firm, and must be signed by the person or firm, or his or their solicitor (if any), and must be served, or, if posted, must be sent by post in sufficient time to reach the abovenamed not later than 4.00 o'clock in the afternoon on 6 September 1983 (the day before the day appointed for the hearing of the petition or the Friday preceding the day appointed for the hearing of the petition if such day is a Monday or a Tuesday following a public holiday). 8489

In the Supreme Court of Victoria, C.O. 13355 — In the matter of the Companies (Victoria) Code; and in the matter of Doned Pty. Ltd.

Advertisement of Application

Notice is hereby given that an application for the winding up of the abovenamed company by the Supreme Court was on 10 August 1983 presented by Lucar Pty. Ltd. (In Liquidation) and that the said application is directed to be heard before the Court sitting at the Practice Court, Law Courts, Lonsdale Street, Melbourne at the hour of 10.30 o'clock in the forenoon on 29 September 1983; and any creditor or contributory of the said company desiring to support or oppose the making of an order on the said application may appear at the time of hearing by himself or his counsel for the purpose and a copy of the said application will be furnished to any creditor or contributory of the said company requiring the same by the undersigned on payment of the regulated charge for the same.

The Applicant's full address is c/- the office of the Liquidator, Warwick Allen Leeming of the office of Duesburys, Chartered Accountants, 114 William Street, Melbourne.

The Applicant's solicitors are Messrs. Weigall & Crowther of 12th Floor, 459 Little Collins Street, Melbourne.

WEIGALL & CROWTHER, solicitors for the Applicant.

Note — Any person who intends to appear on the hearing of the said application must serve on or send by post to the abovenamed Messrs. Weigall & Crowther, notice in writing of his intention so to do. The notice must state the name and address of the person, or if a firm, the name and address of the firm and must be signed by the person or firm or his or their solicitors (if any) and must be served, or, if posted, must be sent by post in sufficient time to reach the abovenamed not later than four o'clock in the afternoon on 28 September 1983. 8495

In the Supreme Court of Victoria, C.O. 13356 — In the matter of the Companies (Victoria) Code; and in the matter of Severus Investments Pty. Ltd.

Advertisement of Application

Notice is hereby given that an application for the winding up of the abovenamed company by the Supreme Court was on 10 August 1983 presented by Lucar Pty. Ltd. (In Liquidation) and that the said application is directed to be heard before the Court sitting at the Practice Court, Law Courts, Lonsdale Street, Melbourne at the hour of 10.30 o'clock in the forenoon on 29 September 1983; and any creditor or contributory of the said company desiring to support or oppose the making of an order on the said application may appear at the time of hearing by himself or his counsel for the purpose and a copy of the said application will be furnished to any creditor or contributory of the said company requiring the same by the undersigned on payment of the regulated charge for the same.

The Applicant's full address is c/- the office of the Liquidator, Warwick Allen Leeming of the office of Duesburys, Chartered Accountants, 114 William Street, Melbourne.

The Applicant's solicitors are Messrs. Weigall & Crowther of 12th Floor, 459 Little Collins Street, Melbourne.

WEIGALL & CROWTHER, solicitors for the Applicant.

Note — Any person who intends to appear on the hearing of the said application must serve on or send by post to the abovenamed Messrs. Weigall & Crowther, notice in writing of his intention so to do. The notice must state the name and address of the person, or if a firm, the name and address of the firm and must be signed by the person or firm or his or their solicitors (if any) and must be sent by post in sufficient time to reach the abovenamed not later than four o'clock in the afternoon on 28 September 1983. 8496

In the Supreme Court of Victoria, C.O. 13349 — In the matter of the Companies (Victoria) Code; and in the matter of Dalterob Pty. Limited — Advertisement of Application.

Notice is hereby given that an application for the winding up of the abovenamed company by the Supreme Court was on 8 August 1983 presented by Diana Richards and the said application is directed to be heard before the Court sitting at the Practice Court, Law Courts, Lonsdale Street, Melbourne at the hour of 10.30 o'clock in the forenoon on 8 September 1983 and any creditor or contributory of the said company desiring to support or oppose the making of an order on the said application may appear at the time by himself or his counsel for that purpose and a copy of the said application will be furnished to any creditor or contributory of the said company requiring the same by the undersigned on payment of the regulated charge for the same.

The Applicant's official address is C/- Messrs. Cooper, Korbl & Co., of 361 Queen Street, Melbourne, Victoria.

The Applicant's Solicitors are Messrs. Cooper, Korbl & Co., of 361 Queen Street, Melbourne.

COOPER, KORBL & CO.

Note — Any person who intends to appear on the hearing of the said application must serve on or send by post to the abovementioned Cooper, Korbl & Co., notice in writing of his intention so to do. The notice must state the name and address of the person, or if a firm the name and address of the firm and must be signed by the person or firm or his or their solicitors (if any) and must be served or if posted, must be sent by post in sufficient time to reach the abovenamed not later than 4.00 p.m. in the afternoon on 7 September 1983. 8439

In the Supreme Court of Victoria, C.O. 13358 — In the matter of the Companies (Victoria) Code; and in the matter of Nu-Craft Furniture Pty. Ltd.

Notice is hereby given that a petition for the winding up of the abovenamed company by the Supreme Court was on 10 August 1983 presented by Halifax Group Pty. Ltd. and that the said petition is directed to be heard before the Court sitting at Law Courts, William Street, Melbourne at the hour of 10.30 o'clock in the forenoon on 6 October 1983; and any creditor or contributory of the said company desiring to support or oppose the making of an order on the said petition may appear at the time of hearing by himself or his counsel for that purpose and a copy of the petition will be furnished to any creditor or contributory of the said company requiring the same by the undersigned on payment of the regulated charge for the same.

The Petitioner's address is 44-50 William Street, Botany, New South Wales.

The Petitioner's Solicitors are Messrs. G. D. Burnett & Co., 37-39 Albert Road, Melbourne.

G. D. BURNETT & CO. Solicitors for the Petitioner.

Note — Any person who intends to appear on the hearing of the said petition must serve on or send by post to the abovenamed solicitors notice in writing of his intention so to do. The notice must state the name and address of the person, or if a firm, the name and address of the firm and must be signed by the person or firm or his or their solicitors (if any) and must be served, or if posted, must be sent by post in sufficient time to reach the abovenamed solicitors not later than four o'clock in the afternoon on 5 October 1983. 8437

Companies (Victoria) Code
IN THE MATTER OF CROSBY HOME FURNISHERS
PTY. LTD.

Notice is hereby given that at a meeting of shareholders of Crosby Home Furnishers Pty. Ltd. held on 15 August 1983 the following resolution was passed as a Special Resolution:

"That that Company be Wound Up Voluntarily and that Mr. Scott Maurice Nunan of Curtain & Nunan, Chartered Accountants of 486 Sydney Road, Coburg be appointed liquidator".

8452

S. M. NUNAN

Companies Act 1981
G. N. COWARD PROPRIETARY LIMITED
(IN LIQUIDATION)

Notice of Final Meeting

Notice is hereby given that a meeting of members of G. N. Coward Proprietary Limited (In Liquidation) will be held at 146 Langtree Avenue, Mildura in the State of Victoria, on 20 September 1983 at ten o'clock in the forenoon for the purpose of laying before the meeting an account showing how the winding up has been conducted and the property of the company disposed of, and giving any explanation thereof.

Dated 10 August 1983

8440

K. G. ROBBINS, Liquidator

In the Supreme Court of Victoria, C.O. 13359 — In the matter of the Companies (Victoria) Code; and in the matter of Trade Ducting & Heating Pty. Ltd.

Notice is hereby given that a petition for the winding up of the abovenamed company by the Supreme Court was on 10 August 1983 presented by F. C. Lovelock Pty. Ltd. and that the said petition is directed to be heard before the Court sitting at Law Courts, William Street, Melbourne at the hour of 10.30 o'clock in the forenoon on 6 October 1983; and any creditor or contributory of the said company desiring to support or oppose the making of an order on the said petition may appear at the time of hearing by himself or his counsel for that purpose and a copy of the petition will be furnished to any creditor or contributory of the said company requiring the same by the undersigned on payment of the regulated charge for the same.

The Petitioner's address is 497 Blackburn Road, Mt Waverley.

The Petitioner's solicitors are Messrs. G. D. Burnett & Co., 37-39 Albert Road, Melbourne.

G. D. BURNETT & CO. Solicitors for the Petitioner.

Note — Any person who intends to appear on the hearing of the said petition must serve on or send by post to the abovenamed solicitors notice in writing of his intention so to do. The notice must state the name and address of the person, or if a firm, the name and address of the firm and must be signed by the person or firm or his or their solicitors (if any) and must be served, or if posted, must be sent by post in sufficient time to reach the abovenamed solicitors not later than four o'clock in the afternoon on 5 October 1983. 8438

Unclaimed Moneys Act 1962

Register of Unclaimed Moneys held by the—

| Name of Owner on Books and Last Known Address | Total Amount Due to Owner | Description of Unclaimed Money | Date when Amount first became Payable |
|--|------------------------------------|-----------------------------------|--|
| \$ | | | |
| LOLOMA LIMITED | | | |
| Brittain, Noel Cameron and June Rosalind, 395 Mulgrave Rd, Cairns, Qld. | 62.00 | Proceeds | 31.3.76 |
| Halberstater, Dr Leslie, Post Office Box 223, Townsville, Qld. | 62.00 | " | " |
| Brownett, Ada Charlotte, 125 Chloride St, Broken Hill, N.S.W. | 93.00 | " | " |
| Pearl, Cyril Altson, care of Ralph Larkins, 21 Euryalus St, Beauty Point, N.S.W. | 155.00 | " | " |
| Sheil, Ellen (estate of), care of Biddulph & Salenger, P.O. Box 344, Milsons Point, N.S.W. | 620.00 | " | " |
| Stephens, Heather Leith F., R.A.D., Tallygaroopna | 115.94 | " | " |
| Stoddart, Ralph J. H. (estate of), care of 86 Smythe Rd, Nedlands, W.A. | 496.00 | " | " |
| Williams, Doris Heather, 2 Francis St, Randwick, N.S.W. | 62.00 | " | " |
| Helaissi, Abdelrahman, 27 Eaton Pl, London, S.W.1, U.K. | 620.00 | " | " |
| 8397 | | | |
| W. B. SIMPSON & SON | | | |
| Lee, Sow Ying, 146 Capel St, North Melbourne | 37.50 | Part Security | 30.1.80 |
| Down, Alex, Flat 12, 202 The Avenue, Parkville | 110.00 | " | 6.1.81 |
| Angel, Peter Robert, 228 Brunswick Rd, Brunswick | 43.60 | " | 30.11.81 |
| Bocquet, Anthony, 228 Brunswick Rd, Brunswick | 43.60 | " | " |
| Foo, Yew Ming, 202 Capel St, North Melbourne | 49.04 | " | 12.3.82 |
| Henry, David Francis, 22 Olympus Dr, Lower Templestowe | 60.00 | " | 15.2.83 |
| Burgher, Robyn, 89 Howard St, North Melbourne | 50.00 | Security | 1.6.77 |
| McMillan, Karen Pamela, 555 Queensberry St, North Melbourne | 150.00 | " | " |
| Ahern, J., 572 Rae St, Fitzroy North | 50.00 | " | 20.11.79 |
| Hazelwood, Richard John, 17 Miller St, West Melbourne | 20.90 | Stamp Duty | 1.5.81 |
| Wynne, Virginia and Szczepanski, Anne, 572 Rae St, North Fitzroy | 48.50 | " | 30.12.80 |
| La, Khai Vinh, 67 Victoria St, Flemington | 12.50 | " | 3.3.80 |
| 8398 | | | |
| HUGH HODSON PTY. LTD | | | |
| Phillips, Jason, "Belmore Park", Tinks Rd, Narre Warren | 20.00 | Bond | 30.7.77 |
| 8474 | | | |
| MICHAELIS BAYLEY LTD. | | | |
| Handbury, Alan J. (estate of), 64 Coppin St, East Malvern | 69.75 | Dividend | 15.4.81 |
| Waters, John F., P.O. Box 3, Neutral Bay Junction, N.S.W. | 75.00 | " | " |
| Waters, May, 7/37 Glen St, Milsons Point, N.S.W. | 37.40 | " | " |
| Hocking, Enid C., 9 Ernie St, Mont Albert | 11.10 | " | 10.11.81 |
| 8475 | | | |

Section 140 (3) (a)

RAYMOND TATE

No. 160 of 1982 Part X

Notice to creditors of intention to declare first dividend

Creditors are advised that it is the intention of the Trustee to declare a first dividend in the above administration on 31 August, 1983.

Creditors who have not yet lodged their Proof of Debt are now requested to do so or be excluded from the Dividend.

E. P. TAYLOR, trustee, 583 Hampton Street, Hampton, telephone 598 7077 8459

Creditors, next of kin or others having claims in respect of the estate of Ronald Ian Niblett, late of 4 Bluewater Avenue, Balnarring, in the State of Victoria, deceased, who died on 22 February 1983, are to send particulars of their claims to the Administratrix care of the undermentioned solicitors by 26 October 1983 after which date the Administratrix will distribute the assets having regard only to the claims of which she then has notice.

DAVID GIBBS & ASSOCIATES, solicitors, 30 Victoria Street, Hastings 8460

LAURENCE JAMES HICKEY, formerly of Benjeroop, but late of Murrabit, in the State of Victoria, farmer, deceased

Creditors, next of kin and all other persons having claims against the estate of the said deceased are required by Allan Hampton Hickey (in the Will referred to as Alan Hampton Hickey) of Church Street, Murrabit aforesaid, Bus Proprietor, the Executor of the estate of the said deceased to send particulars of such claims to him care of the undermentioned solicitors on or before 19 October 1983 after which date he will distribute the assets having regard only to the claims to which he then has notice.

BASILE & CO., barristers & solicitors, 46 Wellington Street, Kerang, Vic. 3579 8467

HUGH McKENZIE, late of 17 East Street, Kerang in the State of Victoria, retired farmer, deceased

Creditors, next of kin and all other persons having claims against the estate of the said deceased are required by Heather-belle Jean Brown of Kerang aforesaid, married woman, Margaret Rose Cartwright of Kerang aforesaid, married woman and Robert Hugh McKenzie of 69 Boundary Street, Kerang aforesaid, shire employee, the Executors of the estate of the said deceased to send particulars of such claims to them. care

of the undermentioned solicitors on or before 19 October 1983 after which date they will distribute the assets having regard only to the claims to which they then have notice.

BASILE & CO., barristers & solicitors, 46 Wellington Street, Kerang, Vic. 3579 8468

Creditors, next of kin and others having claims in respect of the estate of Allan Morris Clarke, late of Flat 4, 7 Glenroy Road, Hawthorn in the State of Victoria, gentleman, deceased (who died on 9 April 1983), are required to send particulars of their claims to The Equity Trustees Executors and Agency Company Limited, of 472 Bourke Street, Melbourne by 22 October 1983 after which date it will distribute the assets of the deceased having regard only to the claims of which it then has notice.

DAWSON, KENNEDY & CO., solicitors, Sunshine. 8469

Creditors, next of kin and others having claims in the intestate estate of Harold Joseph Edwards, late of 366 Albert Road, South Melbourne, in the State of Victoria, supervisor, deceased, who died on 16 March 1983, are to send the notices of their claims to Christine Marian Edwards of Flat 7, 4 Normanby Road, Windsor in the said State, widow, the Administratrix of the intestate estate of the said deceased care of Leo Browne, solicitor of 180 Elgin Street, Carlton in the said state by 31 October 1983 after which date the said Christine Marian Edwards will distribute the estate having regard only to the claims of which she then has notice.

LEO BROWNE, solicitor, 180 Elgin Street, Carlton. 8533

KATHLEEN MARGARET COUNTY, late of 34 Patterson Avenue, Keilor, married woman, deceased

Creditors, next of kin and others having claims in respect of the estate of the deceased, who died 13 June 1983 are required by her executor, George David Harris of 19 Belmont Road, South Croydon, security investigator, to send particulars to him by 26 October 1983 after which date he may convey or distribute the assets, having regard only to the claims of which he then has notice.

McKEAN & PARK, PITCHER & BUTT, 450 Little Collins Street, Melbourne. 8541

Creditors, next of kin and others having claims in respect of the estate of Selina Mary Neal, formerly of 84 Belgrave-Emerald Road, Belgrave, in the State of Victoria, but late of Lot 239 Lake Street, Loch Sport, in the State of Victoria, spinster, who died on 14 May 1983 are required by the Executors, ANZ Executors and Trustee Company Limited to send particulars to the said company at 94 Queen Street, Melbourne, in the said State by 28 October 1983 after which date it will distribute the assets having regard only to the claims of which it then has notice.

F. J. ORAMES & DOWNING, solicitors, 121 William Street, Melbourne. 8542

ARCHIBALD JOHN STEEL, late of 81 Ford Street, Newport, in the State of Victoria, retired metallurgist, deceased

Creditors, next of kin and others having claims in respect of the estate of the deceased (who died on 7 June 1983) are required by The Perpetual Executors and Trustees Association of Australia Limited of 50 Queen Street, Melbourne, to send particulars of their claims to the said Company by 9 November 1983, after which date it will convey or distribute the assets, having regard only to the claims of which the Company then has notice.

MAHONY & GALVIN, solicitors, 85 Queen Street, Melbourne. 8505

HERBERT RANDLE BROWN late of O'Sheas Road, Catani, farmer, deceased

Creditors, next of kin and others having claims in respect to the estate of the deceased who died on 3 May 1983 are required by the trustees Francis James Brown and Herbert Henry Brown to send particulars of their claims to them care of the undersigned solicitors by 28 October 1983, after which date the Trustees may convey or distribute the assets, having regard only to the claims of which they then have notice.

GRAY, FRIEND & LONG, solicitors, Warragul. 8453

EDWARD RODERICK HOPKINS, late of 78 Napier Street, Essendon, gentleman, deceased

Creditors, next of kin and others having claims against the estate of the said deceased, who died on 24 February 1983 are to send particulars of their claims to Roderick McKenzie McLeod and Jessie Kathleen McLeod C/- Messrs. W. Carew Hardham & Gartlan, solicitors of 974 Main Road, Eltham, by 31 October 1983, after which date they will distribute the assets having regard only to the claims of which they then have notice.

W. CAREW HARDHAM & GARTLAN, solicitors, 974 Main Road, Eltham. 8454

Creditors, next of kin and others having claim against the estates specified below are required to send particulars in writing, of such claims to the personal representatives of such estates, in care of Messrs. Morrison & Teare, solicitors, Numurkah on or before 29 November 1983, after which date the assets of the estates will be conveyed or distributed among the persons entitled thereto, having regard only to the claims to which the representatives shall then have had notice:

Kenneth George Napier of Cobram in the State of Victoria, salesman, deceased (died 13 January 1983).

Ethel Mary Doherty of Cobram in the State of Victoria, widow, deceased (died 14 May 1983).

Caterina Orsida of Cobram in the State of Victoria, married woman, deceased (died 6 September 1982).

Salvatore Rocco Orsida of Cobram in the State of Victoria, retired, deceased (died 19 November 1982).

MORRISON & TEARE, solicitors, Numurkah. 8455

MARY IRENE CONSTANCE POOLE, late of 4 Nott Street, East Malvern, Victoria, gentlewoman, deceased

Creditors, next of kin and others having claims in respect of the estate of the abovenamed deceased who died 19 May 1983 are required to send particulars thereof to the Executor of her will The Equity Trustees Executors and Agency Company Limited of 472 Bourke Street, Melbourne, on or before 27 October 1983, after which date it will distribute the assets in the estate having regard only to the claims of which it shall then have notice.

J. M. SMITH & EMMERTON, solicitors, 224 Queen Street, Melbourne. 8456

Creditors, next of kin and others having claims in respect of the will of Loretta Elizabeth Ahern, late of 762 Inkerman Road, Caulfield, home duties, deceased, who died on 6 November 1982 are requested to send particulars of their claims to the Executor John Eudes Stewart care of the undermentioned solicitor by 2 November 1983, after which date he will distribute the assets having regard only as to the claims of which he then has notice.

JOHN STEWART, 290 Racecourse Road, Newmarket. 8457

MARGARET AGNES O'HAGAN, late of 67 Settlement Road, Belmont, widow

Creditors, next of kin and others having claims in respect of the estate of the deceased, who died on 10 August 1983 are required by the Trustees, William Charles Ainsworth of 117 Yarra Street, Geelong, solicitor and Dorothea Eileen MacKay (referred to in the will as Eileen MacKay) of 77 Settlement Road, Belmont, married woman, to send particulars to them by 24 October 1983, after which date the Trustees may convey or distribute the assets, having regard only to the claims of which they then have notice.

MESSRS. AINSWORTH & CO., solicitors, 117 Yarra Street, Geelong. 8315

Creditors, next of kin and others having claims in respect of the estate of Dorothy Constance Trotter, late of 169 Centre Dandenong Road, Dingley, in the State of Victoria, married woman, deceased, who died on 14 December 1982, are required to send particulars to the Executor, care of the undermentioned solicitors by 24 October 1983, after which date he will distribute the assets having regard only to the claims for which notice has been received.

LYTTLETON & GILLARD, solicitors, 51 Marcus Road, Dingley. 8516

THOMAS NORMAN KALMUND, late of Unit 5, 15 Brindisi Street, Mentone, retired, deceased

Creditors, next of kin and others having claims in respect of the estate of the deceased who died on 28 May 1983 are required by The Perpetual Executors and Trustees Association of Australia Limited of 50 Queen Street, Melbourne and Benjamin George Wilson of 242 Warrigal Road, Cheltenham, retired manager, the applicants for a grant of administration, to send particulars of their claims to the said applicants in the care of the said Company by 9 November 1983, after which date they will convey or distribute the assets having regard only to the claims to which they then have notice.

SHIRLEY BURKE, ROCKAWIN & CO., solicitors, 68 Parkers Road, Parkdale. 8506

Creditors, next of kin and others having claims in respect of the estate of the Anna Patricia McBain, late of Flat 9, 13 Doon Road, Horsham, widow, deceased, who died on 19 June 1983, are required by the Executors to send particulars of their claims to National Trustees Executors and Agency Company of Australasia Limited of 95 Queen Street, Melbourne, on or before 26 October 1983, after which date the Executors will distribute the assets having regard only to the claims of which they then have notice.

MOLOMBY & MOLOMBY, solicitors, 459 Collins Street, Melbourne. 8507

STEVEN KOUNTIOS, late of 75 Geach Street, Broadmeadows, in the State of Victoria, storeman, deceased, intestate

Creditors, next of kin, and others having claims in respect of the estate of the deceased (who died on 16 January 1983), are required by Philippos Kountios of 75 Geach Street, Broadmeadows, in the said State, Telecom supervisor, to send particulars to him care of the undermentioned solicitors by 24 October 1983, after which date the Administrator may convey or distribute the assets, having regard only to the claims of which he then has notice.

SLATER & GORDON, solicitors, 636 Bourke Street, Melbourne. 8508

MATTHEW NOONE, late of 18 Hamilton Street, Sea Lake in the State of Victoria, contractor, deceased

Creditors, next of kin and other persons having claims against the estate of the said deceased who died on 3 August 1983 are required to send particulars of the same to the Executrix Ines Cecilia Noone, in care of the undersigned on or before the 18 October 1983, after which date they will distribute the assets, having regard only to the claims of which they then have notice.

DWYER & BENNETT, barristers & solicitors, 194-208 Beveridge Street, Swan Hill. 8470

WILLIAM MURRAY, late of 29 Eddys Grove, Bentleigh in the State of Victoria, gentleman, deceased

Creditors, next of kin and others having claims in respect of the estate of the above-named deceased who died on 15 January 1983 are required by the Executrix Margaret Ann Labb of "Poplar Bend" Main Ridge in the State of Victoria, married woman, to send particulars of any such claim to the Executrix's solicitors, Messrs. N. D. Kelly & Associates, of 437 Centre Road, Bentleigh in the State of Victoria, by the 31 October 1983, after which date the said Executrix may convey or distribute the assets having regard only to claims of which she or her said solicitors then have notice.

Dated 16 August 1983

N. D. KELLY & ASSOCIATES, 437 Centre Road, Bentleigh, solicitors for the Executrix. 8471

ARTHUR NORMAN CALDER late of 152 Hyde Street, Yarraville in the State of Victoria, retired jeweller, deceased

Creditors, next of kin and others having claims in respect of the estate of the deceased who died on 31 July 1983 are required by the Executor Brian Redmond Smyth of 408 Collins Street, Melbourne in the said State, solicitor to send particulars to the undermentioned firm by 15 November 1983, after which date the said Executor may convey or distribute the assets having regard only to the claims of which notice has by then been given.

SETON WILLIAMS & SMYTH, solicitors, 408 Collins Street, Melbourne. 8472

Creditors, next of kin and others having claims in respect of the estate of Godfrey O'Hagan Hayes, late of 115 George Street, East Melbourne in the State of Victoria, antique and art consultant, who died on 8 June 1983 are hereby required to send particulars of their claims to Vernon Wright Cooper, the Executor of his estate, care of the undermentioned solicitors by the 30 November 1983, after which date he will distribute the assets having regard only to the claims of which he then has had notice.

L'ESTRANGE & KENNEDY, solicitors, 291 Bridge Road, Richmond, 3121. 8473

Creditors, next of kin and others having claims in respect of the estate of Aileen Mary Higgins, late of 13 Cameron Road, Essendon in the State of Victoria, married woman, deceased, intestate, who died on 4 April 1983 are required by the Administrator of the estate George Wallace Higgins of 13 Cameron Street, Essendon in the said State, retired, to send particulars to N. C. Gay & Co., Solicitors of 136 Sydney Road, Brunswick by 28 October 1983 after which date the said Administrator may distribute the assets having regard only to claims of which he then has notice.

N. C. GAY & CO., Solicitors, 136 Sydney Road, Brunswick. 8442

BLANCHE AGNES DOWNING, late of Radford Nursing Home, 87 Radford Road, Reservoir, widow, deceased

Creditors, next of kin and others having claims in respect of the estate of the deceased (who died on 6 May 1983) are required by The Perpetual Executors and Trustees Association of Australia Limited of 50 Queen Street, Melbourne, to send particulars of their claims to the said Company by 26 October 1983 after which date it will convey or distribute the assets, having regard only to the claims of which the Company then has notice.

DUDLEY TREGENT & CO., 422 Collins Street, Melbourne. 8217

JOHN JAMES BUBB, late of Springbank, farmer, deceased (who died 30 January 1983)

Creditors, next of kin and all persons having claims against the estate of the deceased are required to send particulars to the Executor, The Union Fidelity Trustee Company of Australia Limited of 101 Lydiard Street North, Ballarat, on or before 25 October 1983, after which date it will distribute the assets having regard only to the claims to which it shall then have notice.

HEINZ & GORDON, solicitors, 6 Dawson Street North, Ballarat. 8484

All persons having claims against the estate of Frank Ezekiel Morris, late of 57 Albert Street, Sebastopol, gentleman, deceased, probate of whose will was granted 21 July 1983 to Robert William Dobson of 52 Lydiard Street South, Ballarat, Solicitor, the Executor appointed by the said will are hereby required to send particulars thereof in writing to the said Executor on or before 1 November 1983, after which date the said Executor will proceed to distribute the assets of the said deceased having regard only to the claims of which he shall then have had notice and the said Executor will not be liable for the assets so distributed or any part thereof to any person of whose claim he shall not then have had notice.

R. G. DOBSON & CO., 52 Lydiard Street, Ballarat, solicitors for the said Executor. 8485

MARGARET PAULINE KERSHAW, formerly of 9 Oak Crescent, Caulfield North, married woman, but late of Royal Freemasons Homes of 313 Punt Road, Prahran, widow, deceased

Creditors, next of kin and others having claims against the estate of the deceased, who died 3 June 1983, are required by the Executor, ANZ Executors & Trustee Company Limited of 94 Queen Street, Melbourne, to send particulars of their claims to the said Company on or before 27 October 1983, after which date it will distribute the assets having regard only to the claims of which it then has notice.

HOME WILKINSON & LOWRY, solicitors, Level 42, Nauru House, 80 Collins Street, Melbourne. 8504

ELLEN MARGARET PRESNELL, late of Flat 9, 14 Brenbeal Street, Balwyn in the State of Victoria, spinster, deceased

Creditors, next of kin and others having claims in respect of the estate of the abovenamed deceased, who died on 31 March 1983 are required by Marjory Johnson-Turner of 92 Peel Street, Kew in the State of Victoria the personal representative of the said deceased, to send particulars of their claims to her by 28 October 1983 after which date she will convey or distribute the assets having regard only to the claims of which she then has notice.

A. B. NATOLI, LL.B., Solicitor of 24 Cotham Road, Kew. 8446

AGNES DUNLOP, late of 22 Forest Street, Spotswood, married woman, deceased, died 16 March 1983

Claims to the Executor George McNaughton of 301 Francis Street, Yarraville by 2 November 1983.

JOHN F. CARROLL, LL.B., solicitor, 4 Paisley Street, Footscray. 8529

WILLIAM HENRY TRELOAR, late of 26 Donald Street, Footscray, retired meat worker, deceased, died 3 May 1983

Claims to the Executrix, Colleen Grace Treloar of 132 Roden Street, West Melbourne by 2 November 1983.

JOHN F. CARROLL, LL.B., solicitor, 4 Paisley Street, Footscray. 8532

Creditors, next of kin and others having claims in respect of the estate of Edgar Stansbury Jarratt, late of Staffa Private Hotel, Nicholson Street, Fitzroy, pensioner, deceased, intestate, who died 2 June 1983, are required by the Administratrix, Ouida Jarratt of 33 Silk Street, Rosanna, widow, to send particulars of their claim to her care of the undermentioned solicitor by 18 November 1983 after which date the said Administratrix will distribute the assets of the deceased having regard only to the claims of which she then shall have notice.

B. J. WILLIAMS, LL.B., solicitor, 1 Ellesmere Parade, Rosanna. 8530

VERA AGNES SCHLICHTING, late of 18 George Street, Spotswood, widow, deceased, died 18 March 1983

Claims to the Executor, Kevin Woodlands Spurling of 93 The Esplanade, Williamstown by 2 November 1983.

JOHN F. CARROLL, LL.B., solicitor, 4 Paisley Street, Footscray. 8531

Creditors, next of kin and others having claims in respect of the estate of Janetta Marion Walker Montgomery, late of 20 Sussex Street, Middle Brighton, gentlewoman, deceased who died on 27 May 1983 are required to send particulars of their claims to the Executor, John Murray Luke of 40 Dudley Street, Melbourne West, Solicitor, by 26 October 1983 after which date the Executor will distribute the assets having regard only to the claims of which he then has notice.

PROUDFOOT, HORTON & COOKE, Solicitors, 40 Dudley Street, Melbourne West. 8443

JOHN ARTHUR KNOWLES, formerly of 9 Vincent Avenue, Geelong, but late of Begonia House Private Nursing Home, 207 Richard Street, Ballarat, retired farmer, deceased

Next of kin and others having claims in respect of the estate of the deceased who died 22 April 1983 are required by The Perpetual Executors and Trustees Association of Australia Limited of 50 Queen Street, Melbourne, to send particulars of their claims to the said company by 26 October 1983, after which date it will convey or distribute the assets, having regard only to the claims of which the company then has notice.

MALESONS, 121 William Street, Melbourne. 3000 8509

In the Supreme Court of the State of Victoria

SALE BY THE SHERIFF

On 6 October 1983 at 2.30 p.m. at the Sheriff's Office, Writs and Warrants Division, 2nd Floor, 241 William Street, Melbourne (unless process be stayed or satisfied).

All the Estate and Interest (if any) of Thomas Albert Johnston and Margaret Pauline Johnston (shown on Certificate of Title as Thomas Albert Johnstone and Margaret Pauline Johnstone) of 11 Maretime Court, Frankston as joint proprietors

of an estate in fee simple in the land described in Certificate of Title Volume 9084 Folio 574 upon which is erected a dwelling and outbuildings known as No. 11 Maretimo Court, Frankston.

Registered Mortgage No. J358649 and Caveat No. J633505 affects the said estate and interest.

Terms — Cash only

8537

L. ROUNTREE, Sheriff's Officer

In the Supreme Court of the State of Victoria

SALE BY THE SHERIFF

AT THE BEST PRICE OFFERED

On 13 October 1983 at 2.30 p.m. at the Sheriff's Office, Writs and Warrants Division, 2nd Floor, 241 William Street, Melbourne (unless process be stayed or satisfied).

All the Estate and Interest (if any) of Ramo Prentic of 14 Colin Avenue, Park Orchards as joint proprietor with Milosava Prentic of an estate in fee simple in the land described in Certificate of Title Volume 8268 Folio 439 upon which is erected a detached dwelling known as No. 14 Colin Avenue, Park Orchards.

Registered Mortgage No. J228276 affects the said estate and interest.

Terms — Cash only — to be sold to the highest bidder — no reserve set.

8538

L. ROUNTREE, Sheriff's Officer

In the Supreme Court of the State of Victoria

SALE BY THE SHERIFF

AT THE BEST PRICE OFFERED

On 13 October 1983 at 2.30 p.m. at the Sheriff's Office, Writs and Warrants Division, 2nd Floor, 241 William Street, Melbourne (unless process be stayed or satisfied).

All the Estate and Interest (if any) of Godfrey Alexander Winston Mansfield of 52 McComb Boulevard, Frankston, as joint proprietor with Heather Mansfield of an estate in fee simple in the land described in Certificate of Title Volume 8581 Folio 319 upon which is erected a concrete brick dwelling known as No. 52 McComb Boulevard, Frankston.

Registered Mortgage Nos. F885813 and K15314 affect the said estate and interest.

Terms — Cash only — to be sold to the highest bidder — no reserve set.

8539

L. ROUNTREE, Sheriff's Officer

In the Supreme Court of the State of Victoria

SALE BY THE SHERIFF

On 20 September 1983 at 12.00 noon at the Police Station, Port Fairy (unless process be stayed or satisfied).

All the Estate and Interest (if any) of John Colee (shown on Certificate of Title as John Wesley Colee) of Albert Road, Port Fairy as joint proprietor with Phillippa Clare Colee of an estate in fee simple in the land described in Certificate of Title Volume 9379 Folio 447 upon which is erected a timber dwelling on the south side of Albert Road approximately 500 metres from the intersection of Princes Highway and Albert Road, Port Fairy.

Registered Mortgage No. K272174 affects the said estate and interest.

Terms — Cash only

8540

J. GREEN, Deputy Sheriff

In the Supreme Court of the State of Victoria

SALE BY THE SHERIFF

On 13 October 1983 at 2.30 p.m. at the Sheriff's Office, Writs and Warrants Division, 2nd Floor, 241 William Street, Melbourne (unless process be stayed or satisfied).

All the Estate and Interest (if any) of Loukas Karaminis and Sophia Karaminis of 57 Stenson Road, Kealba, as joint proprietors of an estate in fee simple in the land described in Certificate of Title Volume 9240 Folio 651 upon which is erected a house known as No. 57 Stenson Road, Kealba.

Registered Mortgage No. H914859 affects the said estate and interest.

Terms — Cash only

8536

J. GREEN, Deputy Sheriff

**NOTICE OF MAKING OF
STATUTORY RULES
WHICH ARE NOT YET
AVAILABLE**

Notice is given of the making of the following Statutory Rules:

| | |
|-----------|---|
| No. | <i>Forests Act 1958</i> |
| 198/1983. | <i>Forests (Mount Dandenong Observatory Reserve) Regulations 1983</i> |
| | <i>Financial Institutions Duty Act 1982</i> |
| 199/1983. | <i>Financial Institutions Duty (Further Amendment) Regulations 1983</i> |
| | <i>Public Service Act 1974</i> |
| 200/1983. | <i>Public Service Amendment Regulations (No. 10) 1983</i> |
| | <i>Public Service Act 1974</i> |
| 201/1983. | <i>Public Service Amendment Regulations (No. 11) 1983</i> |

**NOTICE OF MAKING AND
AVAILABILITY OF
STATUTORY RULE**

In pursuance of the provisions of the *Subordinate Legislation Act 1962* and the Regulations made thereunder notice is given of the making and availability of the following Statutory Rules:

| | | |
|-------------|--|-------|
| No. | <i>Wildlife Act 1975</i> | Price |
| 197/1983. | <i>Wildlife (Game) (Amendment No. 1) Regulations 1983</i> | 20c |
| No. | <i>Public Service Act 1974</i> | Price |
| PSD56/1983. | <i>Public Service Amendment Determinations (No. 56) 1983</i> | 20c |
| PSD57/1983. | <i>Public Service Amendment Determinations (No. 57) 1983</i> | 20c |

Copies of these Statutory Rules are available and may be purchased at the Victorian Government Bookshop, located at 41 St. Andrews Place, East Melbourne (formerly 7A Parliament Place, Melbourne, 3002). If ordered by mail, remittance should be addressed to "The Government Printer, Box 203, North Melbourne, 3051", and should include 50c delivery and handling fee.

The annual subscription rates for Statutory Rules for the year commencing 1 January 1982, payable in advance are as follows:

| | |
|---|---------|
| *Statutory Rules (other than Public Service Determinations), Pamphlet copies only | \$55.00 |
| Public Service Determinations | \$33.00 |

* The Bound Volume of Statutory Rules is not included in the subscription rate.

F. D. ATKINSON
Government Printer

ERRATUM

In *Government Gazette* No. 78 of 10 August 1983 on page 2558 under the heading "Notice of Making of Statutory Rules which are not yet Available", Rule number 195/1983 should be preceded by the heading "*Public Safety Preservation Act 1958*".

STATE ACTS, 1982

Copies of the following Acts of the Parliament of Victoria may be obtained at the Victorian Government Bookshop, 41 St. Andrews Place, East Melbourne, phone 651 2754 or 651 2759, or from any accredited agent, at the price set opposite to each.

A delivery and handling fee must be added to your remittance when ordering by mail as follows:

| Total Value of Acts Ordered | Delivery and Handling Fee |
|-----------------------------|---------------------------|
| 10c-\$2.00 | 0.60c |
| \$2.05-\$5.00 | \$1.00 |
| \$5.05-\$25.00 | \$1.50 |
| \$25.05-\$75.00 | \$2.00 |
| Above \$75.00 | \$3.00 |

Bound Volumes of 1979 State Acts (\$22.00) and the Index to the Bound Volumes (\$10.00) are also available.

The annual subscription rate for State Acts for the year commencing 1 January 1982 is \$50.

| No. | Price |
|--|--------|
| 9723. The Commercial Bank of Australia Limited (Merger) | \$0.80 |
| 9724. The Commercial Banking Company of Sydney Limited (Merger) | \$0.80 |
| 9725. Stamps (Matrimonial Settlements) | \$0.20 |
| 9726. Stamps (First Purchases of Land) | \$0.40 |
| 9727. Metropolitan Fire Brigades (Amendment) | \$0.20 |
| 9728. Howard Florey Institute of Experimental Physiology and Medicine | \$0.20 |
| 9729. Building Societies (Control) | \$0.20 |
| 9730. Constitution (Executive Council Expenses) | \$0.20 |
| 9731. Appeals Cost Fund (Amendment) | \$0.20 |
| 9732. Supply (1982-83, No. 1) | \$0.40 |
| 9733. Pay-roll Tax (Amendment) | \$0.40 |
| 9734. West Gate Bridge Authority (Transfer of Functions) | \$0.80 |
| 9735. Melbourne and Metropolitan Board of Works (Differential Rating) | \$0.20 |
| 9736. Psychological Practices (Scientology) | \$0.20 |
| 9737. Health (Private Hospitals) | \$0.20 |
| 9738. Racing (Payment of Dividends) | \$0.20 |
| 9739. Optometrists Registration (Amendment) | \$0.20 |
| 9740. Motor Car (Breath Analysing Instruments) | \$0.20 |
| 9741. Victorian Arts Centre (Guarantees) | \$0.20 |
| 9742. Transport Regulation (Tow Trucks) | \$0.20 |
| 9743. Superannuation (Amendment) | \$0.20 |
| 9744. Local Government (City of Richmond) | \$0.40 |
| 9745. Victorian Economic Development Corporation (Amendment) | \$0.60 |
| 9746. Public Authorities (Sinking Funds) | \$0.20 |
| 9747. Workers Compensation (Benefit Rates) | \$0.20 |
| 9748. Transport Regulation (Vehicles) | \$0.20 |
| STATE ACTS, 1982—continued | |
| No. | Price |
| 9749. Weights and Measures (Time for Verification) | \$0.20 |
| 9750. Bourke Street Mall | \$0.60 |
| 9751. Local Authorities Superannuation (Amendment) | \$0.80 |
| 9752. State Employees Retirement Benefits (School Council Employees) | \$0.20 |
| 9753. Parliamentary Superannuation | \$0.20 |
| 9754. Melbourne and Metropolitan Board of Works (Offices) | \$0.20 |
| 9755. Water and Sewerage Districts (Amendment) | \$0.20 |
| 9756. Hospitals Superannuation (Amendment) | \$0.20 |
| 9757. Abattoir and Meat Inspection (Amendment) | \$0.20 |
| 9758. Environment Protection (Penalties) | \$0.20 |
| 9759. Baxter Technical School Land | \$0.60 |
| 9760. Environment Protection (Lead in Petrol) | \$0.20 |
| 9761. Companies (Consequential Amendments) | \$0.40 |
| 9762. Pipelines (Amendment) | \$0.20 |
| 9763. Melbourne Corporation (Election of Council) | \$1.60 |
| 9764. Hospital Benefits (Levy) | \$0.40 |
| 9765. Parliamentary Committees (Joint Investigatory Committees) | \$1.00 |
| 9766. Evidence (Commissions) | \$0.40 |
| 9767. Town and Country Planning (Amendment) | \$0.40 |
| 9768. Lotteries Gaming and Betting (Advertisements) | \$0.20 |
| 9769. Local Government (Board of Review) | \$1.00 |
| 9770. Public Account (Cash Management Account) | \$0.40 |
| 9771. Local Government (General Amendment) | \$1.00 |
| 9772. Petroleum (Submerged Lands) | \$3.20 |
| 9773. Constitution (Governor's Salary) | \$0.20 |
| 9774. Burrumbeet (Russell Reserve) Land | \$0.20 |
| 9775. Seeds | \$1.00 |
| 9776. Co-operative Housing Societies and Co-operation (Amendment) | \$0.20 |
| 9777. Industrial and Provident Societies (Amendment) | \$0.20 |
| 9778. Council of Law Reporting in Victoria | \$0.20 |
| 9779. Dentists (Fees) | \$0.20 |
| 9780. Domicile (Amendment) | \$0.20 |
| 9781. Local Government Department (Director-General for Local Government) | \$0.20 |
| 9782. Health (Amendment) | \$0.20 |
| 9783. Road Traffic (Amendment) | \$0.20 |
| 9784. Health (Privileges) | \$0.20 |
| 9785. Public Lands and Works (Public Projects) | \$0.20 |
| 9786. Residential Tenancies (Amendment) | \$0.20 |
| 9787. Local Government (Pecuniary Interests of Councillors) | \$0.40 |
| 9788. Education Service (Amendment) | \$0.60 |
| 9789. Ethnic Affairs Commission | \$0.40 |
| 9790. Public Account (Amendment) | \$0.20 |
| 9791. Pounds (Amendment) | \$0.40 |
| 9792. Victorian Tobacco Growers (Disposal of Assets) | \$0.40 |
| 9793. Sewerage Districts (Sewerage Schemes) | \$0.40 |
| 9794. Appropriation (1982-83, No. 1) | \$5.60 |
| 9795. Geelong Performing Art Centre Trust (Amendment) | \$0.20 |
| 9796. Aboriginal Lands (Aborigines' Advancement League) (Wall Street, Northcote) | \$0.20 |
| 9797. Pipelines (Fees) | \$0.20 |
| 9798. Closer Settlements (Winding-up) | \$0.20 |
| 9799. Ministry of Transport (Amendment) | \$0.20 |
| 9800. Works and Services Appropriation | \$1.00 |
| 9801. Electoral Commission | \$0.40 |
| 9802. Motor Car (Penalties) | \$0.60 |
| 9803. Environment Protection (Air Pollution Control) | \$0.40 |
| 9804. Liquor Control (Booth Licences) (Amendment) | \$0.20 |
| 9805. Land (Amendment) | \$0.20 |
| 9806. Werribee South Water Supply (Validation) | \$0.20 |
| 9807. Superannuation (Railway Service Employees) | \$0.20 |
| 9808. Film Victoria (Reconstitution) | \$0.20 |
| 9809. State Electricity Commission (Financial Arrangements) | \$0.20 |
| 9810. Motor Car (Registration and Drivers' Licences) | \$0.80 |
| 9811. Local Government (House Builders' Liability) (Amendment) | \$0.80 |
| 9812. Victorian College of Agriculture and Horticulture | \$0.60 |
| 9813. Judges Salaries | \$0.20 |

STATE ACTS, 1982—continued

| No. | Price | |
|--|--------|---|
| 9814. Lotteries Gaming and Betting (Amendment) | \$0.20 | BLANE'S AUTHORIZED NEWSAGENTS, 162 Murray Street, Colac, Victoria 3250. |
| 9815. Public Account (State Development Account) | \$0.20 | CARTER, R. G., ADVERTISING SERVICE PTY. LTD., 129 Church Street, Hawthorn, Victoria 3122. |
| 9816. Trustee (Authorized Investments) | \$0.20 | CORNELL, R. G., 126 Eighth Street, Mildura. |
| 9817. Abattoir and Meat Inspection (Further Amendment) | \$0.20 | FAROE, S. W. & E. P., 79 Henty Street, Casterton, Victoria 3311. |
| 9818. Labour and Industry (Shops) | \$0.20 | FRANKS, H., & CO., 184 Ryrie Street, Geelong, Victoria 3220. |
| 9819. Wheat Marketing (Amendment) | \$0.40 | GORDON & GOTCH AUSTRALASIA LTD., 25-37 Huntingdale Road, Burwood, Victoria 3125. |
| 9820. Water (Penalties and Borrowing Powers) | \$0.60 | HARSTON, PARTRIDGE & CO., PTY. LTD., 455 Little Collins Street, Melbourne, Victoria 3000. |
| 9821. Cemeteries (Amendment) (Commencement) | \$0.20 | KYNETON GUARDIAN PTY. LTD., P.O. Box 18, Kyneton, Victoria 3444. |
| 9822. Eastern Railway Construction (Repeal) | \$0.20 | LONSDALE NEWSAGENCY, 250 Lonsdale Street, Dandenong, Victoria 3175. |
| 9823. Farm Produce Merchants and Commission Agents (Amendment) | \$0.40 | LOVELL'S SHEPPARTON NEWSAGENCY, 246 Wyndham Street, Shepparton, Victoria 3630. |
| 9824. Melbourne and Metropolitan Board of Works (Administration) | \$0.60 | THE MERCANTILE EXCHANGE, 50 Queen Street, Melbourne, Victoria 3000. |
| 9825. Construction Industry (Electrical and Metal Trades) Long Service Leave | \$0.20 | McDONALD'S NEWSAGENCY, 88 Bridge Street, Ballarat, Victoria 3350. |
| 9826. Constitution (Qualification of Electors) | \$0.20 | MCGILL'S AUTHORIZED NEWSAGENCY, 183-185 Elizabeth Street, Melbourne, Victoria 3000. |
| 9827. Railways (Amendment) | \$0.40 | McNAUGHTON, P. R. & L. A., 112-114 Gray Street, Hamilton, Victoria 3300. |
| 9828. Hospitals and Charities (Amendment) | \$0.20 | POWNEY'S AUTHORIZED NEWSAGENCY, 293 Hargreaves Street, Bendigo, Victoria 3550. |
| 9829. Veterinary Surgeons (Amendment) | \$0.40 | PURDIE, J., & CO., 138 Moorabool Street, Geelong, Victoria 3220. |
| 9830. Educational Grants (Continuation) | \$0.20 | SALE AUTHORIZED NEWSAGENCY, 292-294 Raymond Street, Sale, Victoria 3850. |
| 9831. Local Government Acts (Miscellaneous Amendments) | \$0.40 | VERNONS OF RICHMOND, 261 Bridge Road, Richmond, Victoria 3121. |
| 9832. River Entrance Docks Railway Construction (Amendment) | \$0.20 | VIEW POINT AUTHORIZED NEWSAGENCY, 4 View Point, Bendigo, Victoria 3550. |
| 9833. Groundwater (Amendment) | \$0.20 | |
| 9834. Victorian Tourism Commission | \$0.80 | |
| 9835. Country Roads (Lands) | \$0.20 | |
| 9836. Queen Victoria Medical Centre (Guarantees) | \$0.20 | |
| 9837. Pay-roll Tax (Further Amendment) | \$0.60 | |
| 9838. Mildura Irrigation and Water Trusts (Amendment) | \$0.40 | |
| 9839. Metropolitan Fire Brigades Superannuation (Eligibility) | \$0.20 | |
| 9840. Workers Compensation (Amendment) | \$0.20 | |
| 9841. St. Nicholas Hospital (Sale of Land) | \$0.20 | |
| 9842. Land Tax (Amendment) | \$0.20 | |
| 9843. Equal Opportunity (Discrimination against Disabled Persons) | \$1.00 | |
| 9844. Flood Plain Management | \$0.40 | |
| 9845. Fisheries (Fees) | \$0.20 | |
| 9846. Energy Consumption Levy | \$1.40 | |
| 9847. Administration and Probate (Survival of Actions) | \$0.20 | |
| 9848. Director of Public Prosecutions | \$0.60 | |
| 9849. Melbourne College of advanced Education | \$1.20 | |
| 9850. Financial Institutions Duty | \$2.40 | |
| 9851. Wildlife (Fees) | \$0.20 | |
| 9852. Motor Car (General Amendment) | \$0.40 | |
| 9853. State Electricity Commission (Amendment) | \$0.80 | |
| 9854. Egg Industry Stabilization (Amendment) | \$0.20 | |
| 9855. Revocation and Excision of Crown Reservations | \$0.40 | |
| 9856. Wrongs (Dependants) | \$0.20 | |
| 9857. State Bank (Amendment) | \$0.40 | |
| 9858. Sale of Land (Amendment) | \$0.80 | |
| 9859. Freedom of Information | \$1.40 | |
| 9860. Human Tissue | \$1.20 | |
| 9861. Public Account (Trust Funds) | \$1.40 | |
| 9862. River Murray Waters | \$1.40 | |
| 9863. State Law Revision (Repeals) | \$1.60 | |

PUBLICATION OF OFFICIAL MATTER

Attention is invited to the following procedure in relation to the publication of official matter in the *Government Gazette*:

Publication will be facilitated by the submission of carbon copies for the use of the *Gazette* Officer.

1. *Matter submitted to the Executive Council*

Matter submitted to the Executive Council which requires gazettal will normally be published in the issue of the following week.

Where urgent gazettal is required, special arrangements should be made with the *Gazette* Officer, Department of the Premier, Third Floor, 1 Treasury Place, Melbourne. Telephone: 651 2440.

2. *Other matter*

(a) All other matter duly certified by a responsible officer for publication should be lodged with the *Gazette* Officer not later than half-past Nine a.m. on Tuesday.

(b) Lengthy or involved notices should be forwarded several days before publication.

(c) Proofs, which will be supplied only when specifically requested or at the direction of the *Gazette* Officer, should be returned promptly to avoid delay in publication.

(d) No additions or amendments to matters for publication will be accepted by telephone.

AGENTS FOR THE "VICTORIA GOVERNMENT GAZETTE"

The following have been appointed agents to receive Advertisements and Subscriptions for the *Victoria Government Gazette*.

ARMSTRONG'S COMMUNICATIONS PTY. LTD., 191 Queen Street, Melbourne, Victoria 3000.

ARNALL & JACKSON, 390 Barkly Street, Brunswick, Victoria 3056.

BAIRNSDALE AUTHORIZED NEWSAGENCY, 132 Main Street, Bairnsdale, Victoria 3875.

BENALLA AUTHORIZED NEWSAGENCY, 45 Bridge Street, Benalla, Victoria 3672.

| |
|-----------------|
| CONTENTS |
|-----------------|

| | Page |
|---|----------------|
| Appointments | 2634 |
| Contracts | 2627, 2632 |
| Estates of Deceased Persons | 2629 |
| Government Notices | 2619 |
| Lands | 2644 |
| Late Notices | 2647 |
| Melbourne and Metropolitan Board of Works— Notice | 2623 |
| Notice of Making of Statutory Rules | 2667 |
| Orders in Council— | |
| Acts—Geelong Waterworks and Sewerage; Local Government; Crown Land (Reserves); Superannuation; Workers Compensation; Victorian Arts Centre; Geelong Waterworks and Sewerage; Land; Dandenong Valley Authority; Housing; Water | 2635 et seq |
| Private Advertisements | 2650 |
| Proclamations | 2615 |
| Resignations | 2634 |
| State Rivers and Water Supply Commission | 2628 |
| Tenders | 2646 |
| Transport Regulation Board—Public Hearings | 2647 |
| Waterworks Trust | 2630 |



Victoria Government Gazette

No. 82—Thursday, 25 August 1983

Fuel Prices Regulation Act 1981

ORDER FIXING AND DECLARING THE MAXIMUM PRICE OF DECLARED FUELS UNDER SECTION 7

Whereas by Notice dated 30 July 1982 and published in the *Government Gazette* on 4 August 1982 the Minister declared—

- (a) the whole of Victoria to be a proclaimed area; and
- (b) certain kinds of fuel to be declared fuels—

for the purpose of the *Fuel Prices Regulation Act 1981* with effect as from 4 August 1982.

And whereas, pursuant to section 7 of the said Act, the Prices Commissioner may, with respect to any declared fuel, from time to time, by order published in the *Government Gazette* fix and declare the maximum price at which any such fuel may be sold generally or in any part of the State or in any proclaimed area.

Now, therefore, I Allan Herbert Miller Fels, Prices Commissioner, do hereby fix and declare maximum prices inclusive of existing taxes as set out below in the whole of Victoria effective from 12.01 a.m., Thursday, 25 August 1983.

FOR THE FREE DELIVERY AREA

Maximum Bulk Wholesale Price to Resellers:

Motor Spirit 97 RON 43.5 cents per litre
 Motor Spirit 89 RON 42.3 cents per litre
 Automotive Distillate 44.3 cents per litre

Maximum Retail Price:

Motor Spirit 97 RON 47.5 cents per litre
 Motor Spirit 89 RON 46.3 cents per litre
 Automotive Distillate 48.3 cents per litre

FOR AREAS OUTSIDE THE FREE DELIVERY AREA

The same maximum prices as those above apply, plus an amount equivalent to the amount (if any) that, at the time the sale is made, is the freight differential approved by the Petroleum Products Pricing Authority in respect of deliveries of motor spirit or automotive distillate by the vendor to the area where the product is delivered less any subsidy payable under the *States Grants (Petroleum Products) Act 1965*.

This Order supersedes all previous orders.
 24 August 1983

A. H. M. FELS
 Prices Commissioner

PRICES COMMISSIONER

I, Peter Cornelis Spyker, Minister of Consumer Affairs, hereby inform you that I do not propose to give you a direction not to publish this proposed Order under section 7 of the *Fuel Prices Regulation Act 1981*.
 24 August 1983

P. C. SPYKER
 Minister of Consumer Affairs

