



[2939]

PUBLISHED BY AUTHORITY

Victoria Government Gazette

No. 92—Wednesday, 14 September 1983

PROCLAMATIONS

Local Government (Pecuniary Interests of Councillors) Act 1982
No. 9787

DATE OF COMING INTO OPERATION

PROCLAMATION

By His Excellency the Governor of the State of Victoria and its Dependencies in the Commonwealth of Australia, &c., &c., &c.

Whereas by an Act of Parliament of the State of Victoria passed in the thirty-first year of the reign of Her Majesty Elizabeth the Second, Queen of Australia, entitled the *Local Government (Pecuniary Interests of Councillors) Act 1982* (No. 9787), it is amongst other things enacted that the provisions of the said Act shall come into operation on the day or on the respective days to be fixed by proclamation or successive proclamations of the Governor in Council published in the *Government Gazette*.

Now therefore, I, the Governor of the State of Victoria in the Commonwealth of Australia, by and with the advice of the Executive Council of the said State, do by this my proclamation fix Tuesday 8 November 1983 as the day on which the said *Local Government (Pecuniary Interests of Councillors) Act 1982* (No. 9787) shall come into operation.

Given under My Hand and the Seal of the State of Victoria aforesaid, at Melbourne, this sixth day of September in the year of Our Lord One thousand nine hundred and eighty-three and in the thirty-second year of the reign of Her Majesty Queen Elizabeth the Second, Queen of Australia.

(L.S.)

BRIAN MURRAY

By His Excellency's Command

F. N. WILKES
Minister for Local Government

GOD SAVE THE QUEEN!

Land Act 1958 ROAD PROCLAIMED

PROCLAMATION

By His Excellency the Governor of the State of Victoria and its Dependencies in the Commonwealth of Australia, &c., &c., &c.

I, the Governor of the State of Victoria, in the Commonwealth of Australia, by and with the advice of the Executive Council of the said State, pursuant to the provisions of Section 25 (3) (c) of the *Land Act 1958*, do hereby proclaim as road the Crown land hereinafter described, viz:

Municipal District of the Shire of Whittlesea —

Parish of Keelbundora, being the land indicated by hatching on plan hereunder — (K25⁽⁵⁾) (L11-3707)

No. 92—67690/83—Price 60 cents, delivered \$1.20. Subscription rate: \$80 per annum

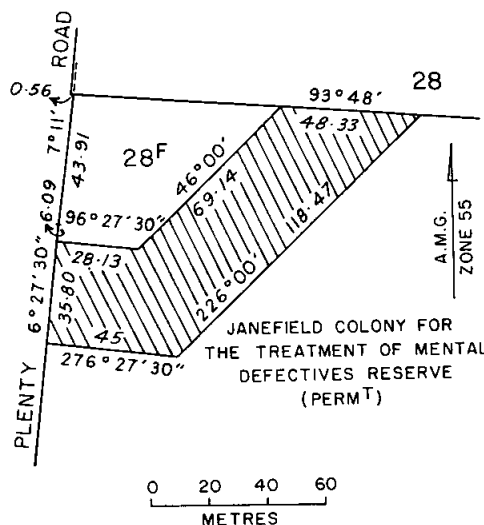

Given under my Hand and the Seal of the State of Victoria aforesaid, at Melbourne, this sixth day of September, in the year of our Lord One thousand nine hundred and eighty-three, and in the thirty-second year of the reign of Her Majesty Queen Elizabeth the Second, Queen of Australia.

(L.S.)

BRIAN MURRAY

By His Excellency's Command

R. A. MACKENZIE
Minister for Conservation
Forests and Lands

GOD SAVE THE QUEEN!

Land Act 1958 ROADS PROCLAIMED

PROCLAMATION

By His Excellency the Governor of the State of Victoria and its Dependencies in the Commonwealth of Australia, &c., &c., &c.

I, the Governor of the State of Victoria, in the Commonwealth of Australia, by and with the advice of the Executive Council of the said State, pursuant to the provisions of Section 25 (3) (c) of the *Land Act 1958*, do hereby proclaim as roads the Crown lands hereinafter described, viz:

Municipal District of the Shire of Kowree —

Township of Edenhope, being the land indicated by hatching on plan hereunder — (E91 (4) (Rs 2365)

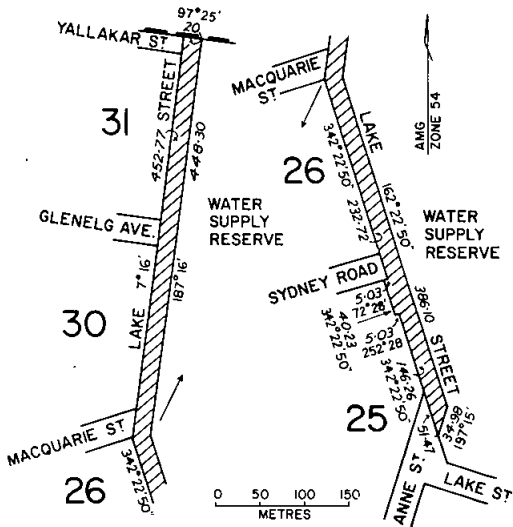

Municipal District of the Shire of Kowree —
Parish of Edenhope, being the land indicated by hatching on plan hereunder — (E91 (5) (Rs 2365))

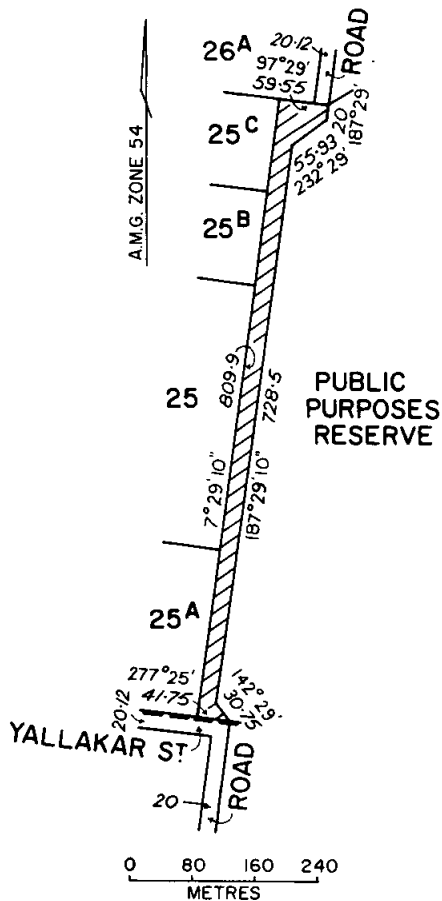

Given under my Hand and the Seal of the State of Victoria aforesaid, at Melbourne, this sixth day of September, in the year of our Lord One thousand nine hundred and eighty-three, and in the thirty-second year of the reign of Her Majesty Queen Elizabeth the Second, Queen of Australia.

(L.S.)

BRIAN MURRAY

By His Excellency's Command

R. A. MACKENZIE
Minister for Conservation
Forests and Lands

GOD SAVE THE QUEEN!

GOVERNMENT NOTICES

Housing Act 1958

NOTICE OF RESOLUTION UNDER SECTION 99 (4) OF ACT 6275

Notice is hereby given that Housing Commission on 18 July 1983 resolved as follows:

"Whereas the Housing Commission in respect of the lands described in the Schedule hereto has given notice to the parties interested under section 9 of the *Lands Compensation Act 1958* as incorporated with the *Housing Act 1958* the lands described in the Schedule hereto are finally appropriated for the purpose of the *Housing Act 1958*.

Schedule

All that piece of land situated in the County of Bourke Parish of Nunawading being part of Allotment A of Portion 48 and being the land described in memorial of Conveyance No. 332 Book 580 in the Office of the Registrar-General at Melbourne".

N. GREEN
Manager, Administration

Water Act 1958

**STATE RIVERS & WATER SUPPLY COMMISSION
OTWAY RURAL DISTRICT**

Notice Pursuant to Section 207A (3)

Notice is given to owners of tenements in the Otway Rural District described in the Schedule to this Notice that the notice published in the *Victorian Government Gazette* on 21 July 1971 pursuant to section 207 (1) is amended insofar as the land described in the schedule hereto is excised from that notice.

Schedule

Description as published in notice of 21 July 1971:—

Crown Allotment 2 Section 23
Parish of Colongulac

known at date of this notice as:—

Lot 6, on L.P. 114901, C.P. A Sec. 14
Parish of Colongulac

Melbourne, 6 September 1983

R. BIRD, Secretary, State Rivers and Water Supply Commission.

ERRATUM

In *Government Gazette* No. 81 of 24 August 1983 on page 2631, column one, ninth line, the words "Shire of Mildura Planning Scheme" should read "City of Mildura Planning Scheme".

Private Agents Act 1966

NOTICE OF RECEIPT OF APPLICATIONS FOR LICENCES UNDER THE PROVISIONS OF THE PRIVATE AGENTS ACT 1966

The Clerk(s) of the Magistrates' Court(s) as listed hereunder hereby give notice that applications, as under, have been lodged for hearing by the said Court(s) on the date(s) specified.

Any person desiring to object to any of such applications must—

- (a) lodge with the respective Clerk of the Magistrates' Court a notice in the prescribed form of his objection and of the grounds thereof;
- (b) cause a copy of such notice to be served personally or by post upon the applicant at least three days before the hearing of the application; and
- (c) send or deliver—
 - (i) where the objection is not made by the officer in charge of the police district in which the Court is situated—a copy of the notice to such officer; and
 - (ii) where the objection is not made by the Registrar or Deputy Registrar—a copy to the Registrar.

Full Name of Applicant*	Place of Abode of Applicant or Nominee	Name of Firm or Corporation	Address for Registration	Type of Licence	Date of Hearing
MAGISTRATES' COURT, HEIDELBERG					
Trothe, Peter John	132 High St, Doncaster West	Racing Security Services	132 High St, Doncaster West	Guard	13.10.83
Dated at Heidelberg 6 September 1983 J. ISAACS, Clerk of the Magistrates' Court					
MAGISTRATES' COURT, PRAHRAN					
Brown, Frederick William	20 Chelmsford Cres, St Albans	Mayne Nickless Ltd	28 Stephenson St, Richmond	Watchman	23.9.83
Davies, Wayne	27 Mudgee St, East Burwood	" "	" "	"	"
Floyd, Albert Barry	17 Marklyn St, Cranbourne	" "	" "	"	"
Hartney, Peter Roy	5 Buffalo Dve, Lalor	" "	" "	"	16.9.83
Hind, James Francis Lewis	7 Mallory Crt, Cranbourne	" "	" "	"	23.9.83
Meyer, Leonard Anthony Rose	26 Ruby St, Balwyn	" "	" "	"	30.9.83
Mowes, Bruce John	12 Bellara Cres, Kealba	" "	390 St Kilda Rd, Melbourne	"	23.9.83
Richmond, Michael Conrade	44 Soudan Rd, West Footscray	" "	28 Stephenson St, Richmond	"	"
Dated at Prahran 2 September 1983 B. MEEHAN, Clerk of the Magistrates' Court					
MAGISTRATES' COURT, WARRNAMBOOL					
Faneco, Glenn	206 Lava St, Warrnambool	George Laurens (Vic) Pty Ltd	182 Lava St, Warrnambool	Process Server	27.9.83
Dated at Warrnambool 6 September 1983 P. LIVINGSTONE, Clerk of the Magistrates' Court					
MAGISTRATES' COURT, MELBOURNE					
Bassindale, Stanley	42 Hadley St, Frankston		340 Abbotsford St, North Melbourne	Watchman	21.9.83
Holland, Shane Francis	95 Barnford Ave, West Meadows		54 Racecourse Rd, North Melbourne	"	"
Dated at Melbourne 6 September 1983 M. QUIRK, Clerk of the Magistrates' Court					
MAGISTRATES' COURT, ELTHAM					
McFarlane, Kevin Gerard	64 Parkstone Ave, Pascoe Vale South		64 Parkstone Ave, Pascoe Vale South	Guard Agent	28.9.83
Dated at Eltham 6 September 1983 S. McMILLAN, Clerk of the Magistrates' Court					

*Or in the case of a firm or corporation, of the Nominee

PRIVATE AGENTS—continued

Full Name of Applicant*	Place of Abode of Applicant or Nominee	Name of Firm or Corporation	Address for Registration	Type of Licence	Date of Hearing
MAGISTRATES' COURT, DROMANA					
Jennings, Ernest John	17 Glenvue Rd, Rye		17 Glenvue Rd, Rye	Guard Agent	20.9.83
" "	" "		" "	Inquiry Agent	"
" "	" "	Rye Investments Pty Ltd. T/AS Nepean Security Service	" "	Process Server	"
" "	" "		" "	Guard Agent	"
Jennings, Betty Alice	" "		" "	"	"
Dated at Dromana 31 August 1983 M. LEA, Clerk of the Magistrates' Court					
MAGISTRATES' COURT, OAKLEIGH					
Chaffield, Terry F.	73 Drummond St, Oakleigh	Compensation Investigation Corp. Pty Ltd.	73 Drummond St, Oakleigh	Process Server	30.9.83
" "	" "		" "	Guard Agent	"
" "	" "		" "	Inquiry Agent	"
Dated at Oakleigh 30 August 1983 A. HARGREAVES, Clerk of the Magistrates' Court					
MAGISTRATES' COURT, MELBOURNE					
Loader, Robert Louis	1 Suffolk Place, Cambellfield	TNT	54 Racecourse Rd, North Melbourne	Watchman	14.9.83
Newton, Russell Arthur	6 Kilby Cl, Epping	Wormalds	340 Abbotsford St, North Melbourne	"	"
Pratt, Malcolm Robert	65 Hedderwick St, Essendon	TNT	54 Racecourse Rd, North Melbourne	"	"
Dated at Melbourne 31 August 1983 M. QUIRK, Clerk of the Magistrates' Court					
MAGISTRATES' COURT, LILYDALE					
Cox, Gerald Bruce	Lot 38 Nugent St, Monbulk		26 North Rd, Lilydale	Watchman	29.9.83
Dated at Lilydale 23 August 1983 D. REES, Clerk of the Magistrates' Court					
MAGISTRATES' COURT, LILYDALE					
Iuan, John Terry	20 Ferris St, Yarra Glen		26 North Rd, Lilydale	Watchman	29.9.83
Dated at Lilydale 31 August 1983 D. REES, Clerk of the Magistrates' Court					
MAGISTRATES' COURT, PRESTON					
Pittway, William Jesse	5 Lennox Cres, Bundoora		5 Lennox Cres, Bundoora	Watchman	28.9.83
Dated at Preston 1 September 1983 T. WILSON, Clerk of the Magistrates' Court					
MAGISTRATES' COURT, MORWELL					
Dyson, Bernard Joachim Edward	5 Walker Pde, Churchill		Lot 4, Old Melbourne Rd, Morwell	Watchman	23.9.83
Dated at Morwell 31 August 1983 K. McMAHON, Clerk of the Magistrates' Court					
MAGISTRATES' COURT, SPRINGVALE					
Nicholson, Kimberley David	15 Hilton Ave, Springvale	M.B.M. Security Service	58 Glendale Rd, Springvale	Watchman	23.9.83
Dated at Springvale 31 August 1983 G. EBERT, Clerk of the Magistrates' Court					

*Or in the case of a firm or corporation, of the Nominee

PRIVATE AGENTS—continued

Full Name of Applicant*	Place of Abode of Applicant or Nominee	Name of Firm or Corporation	Address for Registration	Type of Licence	Date of Hearing
		MAGISTRATES' COURT, WODONGA			
Thompson, Barry James	63 William St, Wodonga		653 Queensberry St, Melbourne	Watchman	27.9.83
		Dated at Wodonga 2 September 1983 P. DODGSON, Clerk of the Magistrates' Court			
		MAGISTRATES' COURT, CHELSEA			
Parry, Alexander John	47 Walkers Rd, Carrum		47 Walkers Rd, Carrum	Guard Agent	11.10.83
		Dated at Chelsea 5 September 1983 H. McINNIS, Clerk of the Magistrates' Court			
		MAGISTRATES' COURT, OAKLEIGH			
Menz, Desmond	6 Devon Crt, Mt. Waverley		6 Devon Crt, Mt. Waverley	Inquiry Agent	30.9.83
		Dated at Oakleigh 5 September 1983 A. HARGREAVES, Clerk of the Magistrates' Court			
		MAGISTRATES' COURT, MORWELL			
Dale, Thomas Frederick	41 Loch Park Rd, Traralgon		Lot 2, Toners Lane, Morwell	Watchman	30.9.83
		Dated at Morwell 1 September 1983 K. McMAHON, Clerk of the Magistrates' Court			
		MAGISTRATES' COURT, PRESTON			
Conybear, Ernest Stanley	Doyles Rd, Reedy Creek		Doyles Rd, Reedy Creek	Watchman	28.9.83
		Dated at Preston 2 September 1983 T. WILSON, Clerk of the Magistrates' Court			

*Or in the case of a firm or corporation, of the Nominee

Co-operation Act 1981

BANYULE PRIMARY SCHOOL CO-OPERATIVE LIMITED
 BLUE GUM PRESS CO-OPERATIVE LIMITED
 DIAMOND CREEK STATE SCHOOL CO-OPERATIVE LIMITED
 IST UPWEY BOY SCOUTS CO-OPERATIVE LIMITED
 FOSTER DISTRICT HIGH SCHOOL CO-OPERATIVE LIMITED
 MACARTHUR AND DISTRICT A.B. CO-OPERATIVE LIMITED
 MERRIGUM FRUIT PRODUCERS CO-OPERATIVE SOCIETY LIMITED
 SPRINGVALE HOMING CLUB CO-OPERATIVE LIMITED
 STRANGWAYS SCHOOL CAMP CO-OPERATIVE SOCIETY LIMITED
 THIRD TWELFTH GLEN WAVERLEY SCOUT CO-OPERATIVE LIMITED
 WATTLE PARK PARISH CO-OPERATIVE CREDIT SOCIETY LIMITED

Notice is hereby given in pursuance of section 192 (8) of the *Co-operation Act 1981* and section 459 (2) of the Companies (Victoria) Code, that, at the expiration of three months from the date hereof the names of the aforementioned societies will, unless cause is shown to the contrary, be struck off the register and the societies will be dissolved.

Dated at Melbourne this 6 September 1983

P. J. ROGAN
Deputy Registrar of Co-operative Societies

Co-operation Act 1981

BENALLA HIGH SCHOOL CO-OPERATIVE LIMITED
 COLIAN FILM CO-OPERATIVE LIMITED
 CREDIT CO-OPERATIVE ASSOCIATION (GEELONG) LIMITED
 CROYDON WEST HIGH SCHOOL CO-OPERATIVE LIMITED
 DROUIN GOLF CLUB CO-OPERATIVE LIMITED
 FERNTREE GULLY BOWLING CLUB CO-OPERATIVE LIMITED
 GLEN WAVERLEY GIRL GUIDES CO-OPERATIVE SOCIETY LIMITED
 KNOX DOG CLUB CO-OPERATIVE LIMITED
 MONTMORENCY PRIMARY SCHOOL ART AND CRAFT CENTRE CO-OPERATIVE LIMITED
 RINGWOOD CO-OPERATIVE CREDIT SOCIETY LIMITED
 SPRINGVALE INTERNATIONAL SHOOTING CO-OPERATIVE LIMITED
 TALINGA HOME BUYERS CO-OPERATIVE 4B LIMITED
 TELSTAR CO-OPERATIVE LIMITED
 WAVERLEY HIGH SCHOOL CO-OPERATIVE ADVANCEMENT SOCIETY LIMITED

Notice of Dissolution of Societies

Notice is hereby given that I have this day registered the dissolution of the abovenamed societies and cancelled their registration under the abovenamed Act.

Dated at Melbourne this 6 September 1983

P. J. ROGAN
Deputy Registrar of Co-operative Societies

Co-operation Act 1981

CHANGE OF NAME OF A SOCIETY

Notice is hereby given that Tramways Employees Credit Co-operative Limited which was incorporated as a Credit Society under the abovenamed Act on 23 June 1969 has registered a change of its name and is now incorporated under the name of Metropolitan Transit Authority Employees Credit Co-operative Limited under the said Act.

Dated at Melbourne this 12 August 1983

P. J. ROGAN

Deputy Registrar of Co-operative Societies

Petroleum (Submerged Lands) Act 1967

COMMONWEALTH OF AUSTRALIA

PROHIBITION OF ENTRY INTO SAFETY ZONE —
WHITING — 1 SUBSEA WELL

I, David Ronald White, Minister for Minerals and Energy for the State of Victoria, the Designated Authority in respect of the area specified as being adjacent to the State of Victoria, under the provisions of Section 119 of the Act hereby prohibit from entering into or remaining in, except with my consent in writing, the area of the safety zone described hereunder all vessels other than vessels engaged in or in connexion with petroleum exploration operations or operations for the recovery of petroleum authorised by me in the area concerned.

Description of Area in Safety Zone

The area which extends to a distance of five hundred metres measured from a subsea well known as Whiting situated at or about Latitude 38 deg. 14 mins. 07 secs. south, Longitude 147 deg. 53 mins. 01 sec. east and located by means of a well head marker buoy described hereunder.

Description of Wellhead Marker Buoy

A yellow buoy fitted approximately three metres above the water line with a radar reflector and a solar actuated lantern having a flashing yellow light showing the letter U in Morse Code at intervals of thirty seconds. The buoy is marked "Esso-Hematite".
Dated this 11 August 1983

Made under the *Petroleum (Submerged Lands) Act 1967* of the Commonwealth of Australia.

DAVID WHITE, Designated Authority

Labour and Industry Act 1958

ORDER OF EXEMPTION UNDER SECTION 80C

Pursuant to the provisions of section 80C of the *Labour and Industry Act 1958*, I, Steven Marshall Crabb, Minister of Transport, acting for and on behalf of the Minister of Labour and Industry, having considered an application from the Council of the Shire of Sherbrooke in relation to premises occupied as a shop by M. Grimwade and H. Mill at 387 Mt Dandenong Tourist Road, Sassafras, and being satisfied that the goods being offered for sale in the shop are attractive to tourists, hereby make this Order granting exemption to—

M. Grimwade and H. Mill, 387 Mt Dandenong Tourist Road, Sassafras

in the shire of Sherbrooke from being required to close and keep closed the shop on—

Saturdays between the hours of 1 p.m. and 8 p.m., and

Sundays and Public Holidays between the hours of 9 a.m. and 8 p.m. — provided that the exemption shall not apply to Good Friday and Anzac Day.

30 August 1983

S. M. CRABB, Minister of Transport, Acting for and on behalf of the Minister of Labour and Industry.

*Town and Country Planning Act 1961*TOWN OF KYABRAM PLANNING SCHEME 1963 —
AMENDMENT NO. 26

Notice of Amendment

In pursuance of the powers conferred by the *Town and Country Planning Act 1961*, the Governor in Council on 13 September 1983 amended the abovementioned scheme in respect of the municipal district of the Town of Kyabram and for which the Council of the Town of Kyabram is the Responsible Authority.

The amendment comes into operation on the date this Notice is published in the *Government Gazette*.

The amendment includes provision for the Council of the Town of Kyabram to enter into agreements with owners.

A copy of the documents may be inspected free of charge, during office hours, at the office of the Ministry for Planning and Environment (Plan Inspection Section), 5th Floor, 235 Queen Street, Melbourne and at the office of the Town of Kyabram, Municipal Offices, Lake Road, Kyabram.

J. B. LAWSON, Acting Secretary for Planning and Environment.

Town and Country Planning Act 1961

MELBOURNE METROPOLITAN PLANNING SCHEME

Notice that a Planning Scheme has been Prepared and is Available for Inspection

Amending Scheme No. 232.

Notice is hereby given that the Melbourne and Metropolitan Board of Works in pursuance of its powers under the *Town and Country Planning Act 1961*, has prepared a Planning Scheme which proposes to amend and vary the Ordinance and to reserve land and to amend and vary land use zonings and reservations of land within the planning area of the Melbourne Metropolitan Planning Scheme which was approved by the Governor in Council on 30 April 1968 and notice thereof published in the *Government Gazette* on 22 May 1968.

A copy of the Amending Scheme has been deposited at the office of the Melbourne and Metropolitan Board of Works, 625 Little Collins Street, Melbourne, at the office of the Ministry for Planning and Environment (Plan Inspection Section), 5th Floor, 235 Queen Street, Melbourne, and as to so much of the Amending Scheme as relates to land within the municipal district of any municipality at the office of such municipality, and will be open for inspection during office hours by any person free of charge.

Any persons affected by the Amending Scheme are required to set forth in writing, any submissions they may wish to make with respect to the Amending Scheme, addressed to the Director of Administration, Melbourne and Metropolitan Board of Works, Box 4342, Melbourne 3001, by 14 December 1983 and to state whether they wish to be heard in respect of their submissions.

Dated 13 September 1983

H. G. FORD, Director of Administration, Melbourne and Metropolitan Board of Works, 625 Little Collins Street, Melbourne 3000.

COUNTRY FIRE AUTHORITY ACT
PERMISSION TO HOLD FIRE BRIGADE
DEMONSTRATION

In pursuance of the provisions of Section 103 of the *Country Fire Authority Act 1958*, the Country Fire Authority has granted approval for the holding of a fire brigade demonstration as under:—

Rural Fire Brigades

At Clyde on Saturday 8 October 1983.

8 September 1983

L. A. CRUICKSHANK, Acting Secretary

CONTRACTS ACCEPTED—(Series 1983-84)

Schedule No. 4/01

Annex to Contract No. 1983/412

LIGHT AIRCRAFT CHARTER SERVICE

Contract from 1 September 1983 to 30 June 1985

1983/412—Campbell-Hicks Airways Pty. Ltd. trading as S.A.S. Southern Air Services

Aircraft Type	Engine	Passenger Capacity	Rate per Flying Hour — 1 pilot	Rate per Flying Hour — 2 pilot
			\$	\$
Cessna 172	Single	3	102.00	—
Beechcraft A36 Bonanza	Single	5	123.00	—
Beechcraft Duchess	Twin	3	151.00	184.00
Cessna 340	Twin	5	176.00	209.00
Piper Navajo	Twin	7	214.00	247.00
Cessna 402B	Twin	9	214.00	247.00
Beechcraft Queenair	Twin	9	281.00	314.00

Detention Time/Rate:

Flying Time Per Day	Detention Time Rate Per Hour
	\$
less than 2 hours	14.00
less than 3 hours	12.00
less than 4 hours	10.00
4 hours or more	nil

Minimum Hiring Charge: nil

Pilots' Overnight Expenses: meals \$17.00/bed \$32.00

Insurance: Indemnity to the Government in relation to:

- (1) Injured passenger: \$100 000 per passenger
- (2) Injury or damage to third parties other than passenger: \$5 000 0000
- (3) Damage to or loss of freight: \$10 000
- (4) Additional personal insurance: \$15.00 per passenger per flight per \$30 000 cover

Alternative Transport:

If aircraft is diverted due to mechanical difficulties a replacement aircraft will be provided. For diversion due to weather, surface transport will be arranged as required at cost.

Minimum Notice:

- Provision of service .. 1½ hours
- Cancellation of flight .. 1½ hours

Approved—R. A. Jolly, Treasurer, 29/8/83.

CONTRACTS ACCEPTED—(Series 1983-84)

Schedule No. 1/78

TYPEWRITERS, MANUAL

Contract from 1 September 1983 to 30 June 1984

1983/434—Olivetti Australia Pty. Ltd., 568 St. Kilda Road, Melbourne. Telephone 529 7299

1983/436—Pacific Typewriter Co. Pty. Ltd., 270 Lonsdale Street, Melbourne. Telephone 663 1444

Item No.	Description of Articles	Rate	Name of Contractor
		\$	
	Typewriters—	each	
1	Foolscap size		
	“Olivetti Linea 98” — 341 mm	280.00*	Olivetti Australia Pty. Ltd.
	“Erika” — 305 mm	245.00*	
2	Brief size, “Erika” — 350 mm	265.00*	Pacific Typewriter Company
3	Policy size, “Erika” — 455 mm	285.00*	Pty. Ltd.

* Machines are guaranteed for a period of 12 months against faulty parts or workmanship. Trading terms are net 30 days.

Approved R. A. Jolly, Treasurer, 8/9/83.

CONTRACTS ACCEPTED—(Series 83-84)**PUBLIC WORKS**

His Excellency the Governor of the State of Victoria by and with the advice of the Executive Council thereof has by Order made on 6 September 1983 approved of the acceptance by the Minister of Public Works of the under-mentioned offers without public tenders being invited, viz:

Offer of I. & M. Stiglic for building works to caretakers residence, Ripponlea Primary School, for the sum of fourteen thousand nine hundred and seventy dollars (\$14,970.00)—125823/1.

Offer of P. Slattery & Co. Pty. Ltd. for professional services (Quantity Surveying) at Westmeadows Heights High School for the sum of forty-four thousand dollars (\$44,000.00)—120167P.

Offer of Tracey Brunstrom & Hammond Pty. Ltd. for professional services (Programmer) at the Rialto Project, 487-505 Collins Street, Melbourne, for the sum of thirteen thousand dollars (\$13,000.00)—P.118399/5.

TOM FORRISTAL
Clerk of the Executive Council

At the Executive Council Chamber,
Melbourne, 6 September 1983

CONTRACTS ACCEPTED—(Series 1983-84)**PUBLIC WORKS**

CLEELAND—cyclic maintenance, High School — \$199 874.82 — I. & M. Stiglic, Endeavour Hills.

FOOTSCRAY — construction building works, Footscray TAFE College — \$3 673.80 — Watts Holdings Ltd., Hawthorn.

HEIDELBERG WEST — PABX telephone system, Education Department Regional Headquarters — \$58 742.00 — Telecom Australia, Melbourne.

KALLISTA — building work, Primary School — \$18 212.00 — John Trotter & Son Pty. Ltd., Boronia.

KEW — audiometric testing room, Kew Children's Cottage — \$10 500.00 — R. & E. Singer, Glen Waverley.

MELBOURNE — adaptations fitting out works, Proposed Word Processing Areas, Floors 2 and 5 — \$43 319.00 — Schiavello Bros. (Vic.) Pty. Ltd., Tullamarine.

MOORABBIN — alterations/improvements and internal painting, College of TAFE — \$44 900.00 — M.D.M. Batarilo, Noble Park.

OXLEY SHIRE — internal and external renovations and extensions, Byrne Primary School — \$18 577.00 — Rose City Homes Pty. Ltd., Benalla.

SEA LAKE — building works, Police Station — \$10 955.00 — Onley's Holdings Pty. Ltd., Donald.

SERENDIP — cleaning of conservation, 1 September 1983 to 31 August 1986 — \$13 026.00 — Cachia Cleaning Service, West Footscray.

SEYMOUR SHIRE — repairs and painting, Tallarook Primary School — \$18 400.00 — Ballard Painting Services, West Meadows.

TIMBOON — interior and exterior painting and renovations, High School — \$119 400.00 — F. & L. Boschini Holdings Pty. Ltd., Bentleigh East.

WALKERVILLE — transfer, re-erection and renovation, Primary School — \$10 250.00 — N. B. & H. H. Schack, Toora.

WINCHELSEA — interior and exterior repairs and painting, Higher Elementary School — \$98 862.00 — H. & J. Knevit, Belmont.

WYCHEPROOF SHIRE — building works, Sea Lake Police Station — \$10 955.00 — Onley's Holdings Pty. Ltd., Donald.

D. J. LITTLE, Director General, 5.9.1983

Police Offences Act 1958, No. 6337

DIVISION 1A — STATE CLASSIFICATION OF PUBLICATIONS BOARD

Take note that the State Classification of Publications Board has classified the following publications in accordance with the provisions of Section 180H (1) of the *Police Offences Act 1958*.

Each publication shall be subject to the following restrictions:

- (a) It shall not be offered for sale, sold or delivered to any person under the age of 18 years;
- (b) It shall not be made available for inspection or perusal by any person under the age of 18 years;
- (c) It shall not be exhibited or displayed in any place to which persons under the age of 18 years have access or so that it is visible from any such place;
- (d) It shall not be advertised in any manner whatsoever.

Schedule of Publications

<i>Title</i>	<i>Distributor</i>
Bondage Annual, No. 4	View Productions Pty. Ltd.
Centurians, No. 17	View Productions Pty. Ltd.

J. ROGERSON, Secretary
State Classification of Publications Board

Police Offences Act 1958, No. 6337

DIVISION 1A — STATE CLASSIFICATION OF PUBLICATIONS BOARD

Take note that the State Classification of Publications Board has classified the following publications in accordance with the provisions of Section 180H (1) of the *Police Offences Act 1958*.

Each publication shall be subject to the following restrictions:

- (a) It shall not be offered for sale, sold or delivered to any person under the age of 18 years;
- (b) It shall not be made available for inspection or perusal by any person under the age of 18 years.

Schedule of Publications

<i>Title</i>	<i>Distributor</i>
About Love, Vol. 1	View Productions Pty. Ltd.
American Gentlemen	Gordon & Gotch Ltd.
Big Boobs, November 1983	Gordon & Gotch Ltd.
Blueboy, September 1983	Gordon & Gotch Ltd.
Blue Video, Vol. 1 No. 1	Gordon & Gotch Ltd.
Buf, November 1983	Gordon & Gotch Ltd.
Club International, Vol. 12 No. 9	Gordon & Gotch Ltd.
Couples — Bedside Companion — November 1983	Gordon & Gotch Ltd.
Fiesta, Vol. 17 No. 9	Gordon & Gotch Ltd.
Forum, October 1983	Gordon & Gotch Ltd.
Giant Rapier Talks, No. 7	View Productions Pty. Ltd.
The 'Girl Next Door', November 1983	Gordon & Gotch Ltd.
The Girls of Penthouse, No. 8	Gordon & Gotch Ltd.
Knave, Vol. 15 No. 8	Gordon & Gotch Ltd.
Mandate, October 1983	Gordon & Gotch Ltd.
Mayfair, Vol. 18 No. 9	Gordon & Gotch Ltd.
Men Only, Vol. 48 No. 9	Gordon & Gotch Ltd.
Penthouse, October 1983	Gordon & Gotch Ltd.
Playboy, October 1983	Gordon & Gotch Ltd.
Playgirl, October 1983	Gordon & Gotch Ltd.
Razzle, Vol. 1 No. 6	Gordon & Gotch Ltd.
Senses	View Productions Pty. Ltd.
Soldier of Fortune, October 1983	Gordon & Gotch Ltd.

J. ROGERSON, Secretary
State Classification of Publications Board

Police Offences Act 1958, No. 6337

DIVISION 1A — STATE CLASSIFICATION OF PUBLICATIONS BOARD

Take note that the State Classification of Publications Board has classified the following publications in accordance with the provisions of Section 180H (1) of the *Police Offences Act 1958*.

Each publication shall be subject to the following restrictions:

- (a) It shall not be offered for sale, sold or delivered to any person under the age of 18 years;
- (b) It shall not be made available for inspection or perusal by any person under the age of 18 years;
- (c) It shall not be exhibited or displayed in any place to which persons under the age of 18 years have access or so that it is visible from any such place.

Schedule of Publications

<i>Title</i>	<i>Distributor</i>
Bizarre, Vol. 1 No. 2	View Productions Pty. Ltd.
Color Climax, No. 122	Media Distributors of Victoria Pty. Ltd.
Freedom In Marriage, Vol. 2	View Productions Pty. Ltd.
Hot Talk — The Best of Forum Letters	Gordon & Gotch Ltd.
John Holmes and Seka's Sex Party	View Productions Pty. Ltd.
Milky Mom, No. 1	View Productions Pty. Ltd.
New Cunts, No. 27	Media Distributors of Victoria Pty. Ltd.
Piss & Anal, No. 4	Claredale Holdings Pty. Ltd.
Teenage Sex, No. 26	Claredale Holdings Pty. Ltd.
Velvet Talks! No. 11	Gordon & Gotch Ltd.

J. ROGERSON, Secretary
State Classification of Publications Board

Farm Produce Merchants and Commission Agents Act 1965
(No. 7274)

LIST OF NAMES AND ADDRESSES OF LICENCE HOLDERS TO WHOM LICENCES HAVE BEEN ISSUED DURING AUGUST 1983

In accordance with the above Act, those issued with a Merchant's or Commission Agent's licence have paid the prescribed contribution to the Farm Produce Merchants and Commission Agents Guarantee Fund. All licences, unless earlier surrendered or cancelled, shall continue in force until 30 June 1984.

MERCHANTS

Name; Principal place of business

- Athanasi, T. and M., and Sons, "B" Store No. 238, Melbourne Wholesale Fruit and Vegetable Market, Footscray 3011.
- Bellarine Fruit Supply, 11 Tanner Street, Breakwater 3219.
- Central Export Packers Pty. Ltd., Store 344 Melbourne Wholesale Fruit and Vegetable Market, Footscray 3011.
- Express Foods, 3 Reilly Street, Ringwood 3134.
- Granieji and Company Pty. Ltd., Stores 204-205 Melbourne Wholesale Fruit and Vegetable Market, Footscray 3011.
- Heba, T.L. and A.C., Curlewis Road, Curlewis 3222.
- Jet-Pak International Pty. Ltd., 1-13 Husseys Lane, South Warrendyte 3134.
- *Nanango Pty. Ltd., trading as Ireland's Florist, 96 Flinders Street, Melbourne 3000. *Licence transferred from Flowers and Plants.
- Napoleone, J. M., Creek Road, Wandin East 3139.
- North West Wholesale Fruit & Vegetable Company, 21 McFie Street, Devonport 7310.

Rodney J. Cartledge and Company, 35 Peel Street South, Ballarat 3350.

T. & G. Produce, 16-18 Olympic Street, Griffith 2680.

Velisha Bros., Store 216, Melbourne Wholesale Fruit and Vegetable Market, Footscray 3011.

Warral Apiaries, Dempsey Street, Myers Flat 3556.

COMMISSION AGENTS

Name; Principal place of business

B. and P. Sunshot Exports Pty. Ltd., Midland Highway, Mooropna 3629.

Blue Moon Exports Pty. Ltd., Toolamba Road, Mooropna 3629.

Luciano, E. and Son, Melbourne Wholesale Fruit and Vegetable Market, Footscray 3011.

McKenzie Fruits, 3 Pine Ridge, Donvale 3111.

*Robertson, A. R., Victoria Street, Trentham 3458.

*Exempt from prescribed contribution to the Guarantee Fund under Regulation 9 (1) of the Farm Produce Merchants and Commission Agents Regulations 1966.

Vizzarri, G. and M., Koo Wee Rup Road, Koo Wee Rup 3981.

SECONDARY WHOLESALERS

Name; Principal place of business

Golden Gardenia, 17 Church Street, Morwell 3840.

Kingfruit — G. Hume, 7 Forest Road, Orbost 3888.

Noel Uren Wholesale, 5 Station Street, Koo Wee Rup 3981.

D. E. HORE

Acting Director-General of Agriculture

Melbourne and Metropolitan Board of Works

NOTICE TO THE OWNERS OF TENEMENTS IN THE UNDERMENTIONED STREETS AND THE PRIVATE STREETS, LANES, COURTS AND ALLEYS OPENING THERETO

The main pipe in the said streets being laid down, the owners of all tenements situated as under are hereby required on or before 17 October 1983 to cause a proper pipe and stop cocks to be laid so as to supply water within such tenements from the main pipe.

Berwick

Raymond McMahon Boulevard, from Hellyer Way westwards and northwestwards 275 metres.

Merryn Close, the total street from Raymond McMahon Boulevard southwestwards.

Derry Close, the total street from Raymond McMahon Boulevard northwards.

Nyora Close, the total street from Raymond McMahon Boulevard southwestwards.

Garner Court, the total street from Raymond McMahon Boulevard northwards.

Shafer Court, the total street from Kinkead Crescent southwestwards.

Diamond Valley

Collendina Crescent, from 40 metres north of Eastgate Drive northeastwards and eastwards 217 metres.

Wayland Court, from 200 metres east of Everleigh Drive further northeastwards 85 metres.

Doncaster and Templestowe

Santa Rosa Boulevard, from 45 metres west of Moor Park Crescent further westwards 76 metres.

Warner Court, from Craig Road northwards 272 metres.

Keilor

Sunshine Avenue, from Biggs Street to William Street.

Sunshine Avenue, from William Street northwestwards 240 metres.

Biggs Street, from Glyndon Avenue to Sunshine Avenue.

Anderson Street, from Biggs Street to Perrett Avenue.
 William Street, from Sunshine Avenue to Anderson Street.
 William Street, from Anderson Street westwards 270 metres.
 Perrett Avenue, from the eastern arm of Anderson Street to William Street.

Knox

Barmah Road, from the south building line of Tanderra Crescent northwards 51 metres.

Pacific Close, the total street from 34 metres west of Barmah Road northwards.

Tanderra Crescent, from 5 metres southwest of Quixley Grove, further southwestwards 116 metres.

Danielle Court, the total street from Tanderra Crescent northwards.

Virgo Place, the total street from Cornelius Drive northwards.

Libra Court, the total street from Cornelius Drive southwards.

Leo Close, from Cornelius Drive northeastwards 57 metres.

Cornelius Drive, from 30 metres north of St Bernards Court northeastwards, eastwards and southeastwards 293 metres.

Whittlesea

Marshall Drive, from 15 metres northeast of Childs Road further northeastwards 260 metres.

Thompson Circuit (Western Arm) from Marshall Drive northwards 36 metres.

Thompson Circuit (Eastern Arm) from Marshall Drive northwards 35 metres.

Hope Court, the total street from Marshall Drive southeastwards.

Wright Court, the total street from Marshall Drive southeastwards.
 6 September 1983

H. G. FORD
 Director of Administration

MELBOURNE AND METROPOLITAN BOARD OF WORKS
 Amendment

Notice of Declaration of Sewerage Areas appearing in the *Victoria Government Gazette* No. 72, dated 20 July 1983 is amended as follows:

Sewerage Area No. 4658

Shire of Diamond Valley — For the expression 'and 322 Liddesdale Grove' there shall be substituted the expression 'and 332 Liddesdale Grove'.

H. G. FORD, Director of Administration

PUBLIC TRUSTEE ACT 1958, SECTION 17

I hereby give notice that on 29 August 1983, the Public Trustee filed an Election to Administer the following deceased person's estate in accordance with Section 17 of the *Public Trustee Act* 1958:

Elwell, George Hunt, formerly of No. 15 War Haven Homes, Cairns, Queensland, but late of Chadstone Gardens Retirement Centre, 597 Warrigal Road, Ashwood, retired aircraft inspector, died 9 November 1982.

I hereby give notice that on 31 August 1983, the Public Trustee filed Elections to Administer the following deceased persons' estates in accordance with Section 17 of the *Public Trustee Act* 1958:

Brealey, Arthur Lewis, late of Beechworth, retired, died 18 May 1983.

Carstens, Mabel Lydia Ann, also known as Mabel Lydia Carstens, formerly care of 23 Canterbury Street, Moonee Ponds, but late of Alima Private Nursing Home, 34 Scott Street, Essendon, widow, died 26 July 1983.

Hotchin, Francis Joseph, formerly of 24 Barnfather Street, East Geelong, but late of Grace McKellar House, 45-95 Ballarat Road, North Geelong, pensioner, died 4 July 1983.

James, Hugh John, late of 68 Lisbeth Avenue, Mitcham, draughtsman, died 25 May 1983.

McGowan, Thomas Greville, late of 10 Upton Street, Altona, retired storeman, died 29 May 1983.

Vickers, William, late of 26 Larch Street, Blackburn, pensioner, died 3 July 1983.

7 September 1983

168 Exhibition Street,
 Melbourne 3000

P. T. SPENCER
 Public Trustee

Creditors, next of kin and others having claims against the estate of any of the undermentioned deceased persons are required to send particulars of their claims to the Public Trustee, 168 Exhibition Street, Melbourne, Victoria 3000, the personal representative, on or before 21 November 1983 after which date the Public Trustee may convey or distribute the assets having regard only to the claims of which the Public Trustee then has notice:—

Bastfield, David, late of 19 Yew Tree Road, Hasbury, Halesowen, England, retired, died 20 June 1969.

Brealey, Arthur Lewis, late of Beechworth, retired, died 18 May 1983.

Carstens, Mabel Lydia Ann, also known as Mabel Lydia Carstens, formerly care of 23 Canterbury Street, Moonee Ponds, but late of Alima Private Nursing Home, 34 Scott Street, Essendon, widow, died 26 July 1983.

Chambers, Winifred, formerly of 48 Auburn Avenue, Northcote, but late of Regent Private Nursing Home, 44 Regent Street, Preston, widow, died 29 June 1983.

Eager, Jean Doris, late of Hokitika, New Zealand, widow, died 11 May 1983.

Elwell, George Hunt, formerly of No. 15 War Haven Homes, Cairns, Queensland, but late of Chadstone Gardens Retirement Centre, 597 Warrigal Road, Ashwood, retired aircraft inspector, died 9 November 1982.

Green, William Henry, late of 59 Walsh Street, Coburg East, retired railway employee, died 24 April 1983.

Hotchin, Francis Joseph, formerly of 24 Barnfather Street, East Geelong, but late of Grace McKellar House, 45-95 Ballarat Road, North Geelong, pensioner, died 4th July 1983.

Hunter, Maxwell, late of 47 Woodhouse Street, Invercargill, New Zealand, freezing worker, died 28 July 1982.

James, Hugh John, late of 68 Lisbeth Avenue, Mitcham, draughtsman, died 25 May 1983.

Luttrell, Geoffrey Law, late of Bundoora, pensioner, died 28 December 1982.

McGowan, Thomas Greville, late of 10 Upton Street, Altona, retired storeman, died 29 May 1983.

Pengelly, James Foster, late of 9 Fincham Street, Ballarat, builder, died 25 March 1983.

Vickers, William, late of 26 Larch Street, Blackburn, pensioner, died 3 July 1983.

Melbourne, 7 September 1983

P. T. SPENCER
 Public Trustee

HEALTH ACT

The Health Commission of Victoria has received from the following proprietors of the Special Accommodation Houses listed below, applications for exemption from all or any of the requirements of Division 3A of Part XII of the *Health Act* 1958 and the regulations made under Division 1, 2 and 3A of the same Part.

The Commission is satisfied that:

1. The subject premises will not be used to accommodate more than four people exclusive of the family of the proprietor; and that

2. The proprietors have no interest in the ownership, management or conduct of any other Special Accommodation House or in any company which is the proprietor of any other Special Accommodation House.

The Commission hereby grants the above exemptions to the proprietors listed in respect of the premises named herein subject to the following conditions:

- (a) the proprietor shall comply at all times with paragraph (1) and (2) above;
- (b) no more than four residents are accommodated at one time;
- (c) a responsible person is always available and on the premises for residents to contact in any emergency;
- (d) an emergency bell is always available to residents;
- (e) medications are distributed by the proprietor or a responsible person nominated by him or her;
- (f) a resident who is suffering from a condition such as would require him or her to be lodged in a hospital or nursing home shall not remain in the premises;
- (g) a record is kept of each resident's full name, date of birth, next of kin, pension number, attending doctor and medications;
- (h) that adequate fire precautions are maintained;
- (i) this exemption will be reviewed from time to time but will continue until this certificate is revoked.

Subject Premises	Proprietor(s)	Exemption No.
743 Warrigal Road, South Oakleigh	Mrs G. Robertson	18

Dated at Melbourne this day, 19 August 1983

B. P. McCLOSKEY, Director, Public Health Division, Health Commission of Victoria.

Nurses Act 1958 (No. 6328)

ELECTION OF PERSONS FOR APPOINTMENT TO THE VICTORIAN NURSING COUNCIL

Nursing Council Regulations

At an election held on 19 August 1983 the undermentioned persons were elected for appointment as members of the Victorian Nursing Council.

- (i) six (6) registered general nurses to be elected by registered general nurses holding current annual practising certificates as such:—
 - Dorothy Rae Anstee
 - Joyce Buckland
 - Mary Elizabeth Patten
 - Elsie June Allen
 - Bernadette Ann Gilmartin
 - Margaret Mary McKinnon
- (ii) one (1) registered mental retardation nurse or psychiatric nurse to be elected by registered mental retardation nurses or psychiatric nurses holding current annual practising certificates as such:—
 - Michael Andrew Leighton
- (iii) two (2) registered State enrolled nurses to be elected by registered State enrolled nurses holding current annual practising certificates as such:—
 - Ricky John Parker
 - Kathleen Grace Bailey

- (iv) one (1) registered midwife to be elected by registered midwives holding current annual practising certificates as such:—

Thelma Jean Matson

- (v) one (1) registered mothercraft nurse to be elected by registered mothercraft nurses holding current annual practising certificates as such:—

Mardi Joy Hatherll.

7 September 1983

J. A. BUSUTTIL, Returning Officer
Victorian Nursing Council Elections

Transport Act 1983

ORDER TO TRANSFER ASSETS

I, Steven Marshall Crabb, Minister of Transport, after causing investigations to be made and after consulting with the Road Construction Authority and the Road Traffic Authority, pursuant to the powers vested in me by Section 81 (1) of the *Transport Act 1983* do hereby order that the assets of the Road Construction Authority listed in the Schedule attached hereto be transferred to the Road Traffic Authority.

Schedule of Assets

Motor vehicles, registered numbers —

AOT 844	BNU 686
AOX 184	BNY 791
BDY 667	BNY 936
BDY 728	BNZ 883
BGG 756	BNZ 951
BGR 485	BON 491
BGY 518	BON 492
BHR 032	BOS 115
BHR 033	BOS 116
BIG 618	BPJ 796
BLK 690	BPK 379
BLM 622	BPU 308
BLO 943	

together with associated equipment with each vehicle including two-way radios, portable weighing devices, measuring rods, measuring tapes, stop signs and torches, stationery and other material ancillary to the performance of the policing of mass and dimensions function and the issue of permits in relation thereto.

Dated 29 August 1983

S. M. CRABB
Minister of Transport

APPOINTMENTS AND RESIGNATIONS

APPOINTMENTS

His Excellency the Governor of the State of Victoria by and with the advice of the Executive Council thereof has by Orders made on 6 September 1983 been pleased to make the undermentioned appointments, viz.:

Department of Community Welfare Services

Honorary Probation Officers

Dianne Patricia Duggan, 1/83 Holmes Road, Moonee Ponds,
Robert Gary Hunt, Spratlings Road, Ross Creek,
Anna Langley, 903 Dana Street, Ballarat,
Bevan Robert Miller, 903 Dana Street, Ballarat,
Stewart Pike, 8 Soyuz Court, Mt. Clear,
James Edward Reeves, Dawson Street South, Ballarat,
Anthony Mark Searle, R.S.D. R505, Ballarat,
Ian Snow, Room 15, Hampton House, 24 Grey Street, St. Kilda,
Anthony John Waldon, 8 Amaroo Crescent, Wodonga,
Virginia Wellard, 903 Dana Street, Ballarat.

Yvonne Young, P.O. Box 149, Werribee, and Julie Zurawiecki, 8 Strathmore Crescent, Hoppers Crossing, to be Honorary Probation Officers for all Adult and Children's Courts in the State of Victoria pursuant to the provisions of Section 507 (2) of the *Crimes Act* 1958 and Section 9 of the *Children's Court Act* 1973 from and inclusive of 30 August 1983.

Department of Crown Lands and Survey

Bailiffs of Crown Lands

Robert Walter Birt and Graham Murphy to be bailiffs of Crown lands, pursuant to the provisions of Section 30 of the *Land Act* 1958, in respect of the reserved Crown lands in the Parish of Wonthaggi known as Cape Paterson Beach Reserve, and with authority to enforce all the Regulations made with respect to the care, protection and management of the said Reserve.

Rs.4057

John Rogers, an employee of the Department of Crown Lands and Survey, to be a bailiff of Crown lands, pursuant to the provisions of Section 30 of the *Land Act* 1958, in respect of all Crown lands in the State of Victoria, and with authority to discharge and exercise all the duties and powers of bailiffs of Crown lands.

X.16^B.

William Ramsay to be a bailiff of Crown lands, pursuant to the provisions of Section 30 of the *Land Act* 1958, in respect of the Crown land in the City of Port Melbourne temporarily reserved for Public Recreation and known as West Gate Park together with the land in the Parish of Melbourne South which is subject to a licence issued pursuant to Section 138 of the *Land Act* 1958 to Stanzo Constructions Company Pty. Ltd. for the purpose of Depositing of Materials (No. 02909/138), and with authority to discharge and exercise all the duties and powers of bailiffs of Crown lands.

Rs.11299.

Health Commission

Member of the Committee of Management of Hospital

Leslie George Judd, as a Member of the Committee of Management of the Oakleigh District Community Hospital pursuant to the provisions of Section 63F (1) of the *Hospitals and Charities Act* 1958, the period of office expiring on 31 December, 1983.

Law Department

Justices of the Peace

Dennis Alan Belcher, 99 Brown Street, Hamilton, Denis Gerard Connors, 37 High Street, Lancefield, David Alexander Coutts, "Moolort", Maryborough, Joan Hardy, 21 Orrong Road, Elsternwick, Peter John Howard, 34 Lee Parade, Leongatha, William Charles McRoberts, 79 George Street, Morwell, Thomas Peter Synan, 19 Stawell Street, Sale, Kay Frances Viola, 11 Heaton Avenue, Elwood, Gordon Charles Walton, Burumbeet, and Robert Murray Williams, 7 High Street, Lancefield, to be Justices of the Peace for the State of Victoria.

Commissioners for Taking Declarations, etc.

Joseph Delooze, 31 Calista Avenue, Clayton, Doreen Joan Foden, 20 Lyell Road, Boronia West, Margaret Osborne, 5/2 Lawson Grove, South Yarra, Geoffrey Hugh Williams, 105 Newlands Road, Coburg, and Frank Wositzky, C.A.B. Offices, Lonsdale Street, Dandenong, to be Commissioners for taking Declarations and Affidavits under the *Evidence Act* 1958.

Bailiff of the Supreme Court

Alan Vernard Bell, 241 William Street, Melbourne, to be a Bailiff of the Supreme Court pursuant to Section 185 (1) of the *Supreme Court Act* 1958 and a Bailiff of Magistrates Courts pursuant to Section 31A of the *Magistrates Courts Act* 1971.

TOM FORRISTAL

Clerk of the Executive Council

At the Executive Council Chamber
Melbourne, 6 September 1983

Liquor Control Act 1968

APPOINTMENT OF LICENSING INSPECTORS

In accordance with the authority conferred upon me by Section 6 of the *Police Regulation Act* 1958, I, John Roderick Hall, Deputy Commissioner of Police, do hereby appoint under subsection (1) of Section 22 of the *Liquor Control Act* 1968, the following Officers of Police as Licensing Inspectors for the Divisions of the Police Districts as shown:—

<i>Division Number</i>	<i>Police District</i>	<i>Rank and Name</i>
4	Altona	Inspector Lawrence Dillon, No. 13836 (from 1.9.83 to 30.9.83).
1	Loddon	Chief Inspector Bryan John Grumley, No. 11782 (from 2.10.83 to 29.10.83).
3	Prahan	Chief Inspector Russell Louis Bertram, No. 12215 (from 21.8.83 to 17.9.83).
2	Heidelberg	Chief Inspector William Benson Macrae, No. 11681 (vice Superintendent McMenemy, No. 10637).

J. R. HALL

9.9.1983 Deputy Commissioner (Administration)

Explosives Act 1960

The Public Service Board, pursuant to the provisions of Section 5 (1) of the *Explosives Act* 1960, hereby appoints John Woods, Keeper of Magazines and Technical Assistant, Third Division, Department of Minerals and Energy, as an Inspector of Explosives, without additional salary.

DR. E. W. RUSSELL, Secretary, Department of Minerals and Energy.

REVOCATION OF APPOINTMENTS

His Excellency the Governor of the State of Victoria, by and with the advice of the Executive Council thereof, has by Orders made on 6 September 1983, revoked the appointments of the persons named hereunder to the offices mentioned, viz.:

Law Department

Bailiffs of the Supreme Court

Leo Kenneth Charles, David Joseph Draper, Owen Victor Daly, James Forsyth, Warwick Lawrence Roach, Bernard Ewart Smith, Allan Alfred Cameron, Thomas Ainsworth Egerton, Colin Paul Jones and David Pomfret as Bailiffs of the Supreme Court pursuant to Section 185 (1) of the *Supreme Court Act* 1958 and Bailiffs of Magistrates Courts pursuant to Section 31A of the *Magistrates Courts Act* 1971.

TOM FORRISTAL

Clerk of the Executive Council

At the Executive Council Chamber,
Melbourne, 6 September 1983

RESIGNATIONS

His Excellency the Governor of the State of Victoria by and with the advice of the Executive Council thereof has by Orders made on 6 September 1983 accepted the resignations of the persons named hereunder of the offices mentioned, viz.:

Law Department

Commissioners for Taking Declarations, Etc.

Bernard John Curtin, Neal John Fitzgerald and Francis Carlton Ralph as Commissioners for taking declarations and affidavits under the *Evidence Act 1958*,

TOM FORRISTAL
Clerk of the Executive Council

At the Executive Council Chamber,
Melbourne, 6 September 1983

ORDERS IN COUNCIL

GEELONG WATERWORKS AND SEWERAGE TRUST

At the Executive Council Chamber, Melbourne, the thirtieth day of August, 1983

Present:

His Excellency the Governor of Victoria
Mr Simpson | Mrs Toner
Mr Mackenzie | Mr White

APPOINTMENT OF A COMMISSIONER

Under the power conferred by the *Geelong Waterworks and Sewerage Act 1958*, and all other powers enabling him in that behalf, His Excellency the Governor of the State of Victoria, by and with the advice of the Executive Council thereof, hereby appoints Raymond Wallace Whiteside to be a Commissioner of the Geelong Waterworks and Sewerage Trust for a period of four years as from 26 September 1983.

And the Honourable David Ronald White, Her Majesty's Minister of Water Supply for the State of Victoria, shall give the necessary directions herein accordingly.

TOM FORRISTAL
Clerk of the Executive Council

LOCAL GOVERNMENT ACT 1958

At the Executive Council Chamber, Melbourne, the sixth day of September, 1983

Present:

His Excellency the Governor of Victoria
Mrs Toner | Mr Wilkes
Mr Jolly | Mr Kent

ROAD DISCONTINUED — SHIRE OF CORIO

Whereas it is provided in section 528(2) of the *Local Government Act 1958*, that where a road (whether or not a public highway but not being a road set out on land of the Crown) or any part thereof is not required for public use, the Governor in Council on the request of the council of the municipality in which such road is situated made not less than one month after publishing in a newspaper generally circulating in the district and posting to the registered proprietor (if any) of the land and the owners and occupiers (if any) of lands abutting or immediately adjacent to the road notice of intention to make such a request may by Order published in the Government Gazette direct that such road or part shall be discontinued and thereupon such road or part shall be discontinued accordingly.

And whereas the Council of the Shire of Corio has requested that the Governor in Council direct that a road between Edison and Picadilly Streets and Viewmont Crescent, Bell Post Hill be discontinued and not less than one month previously has published in a newspaper generally circulating in the district and posted to the registered proprietor of the land in the road and to the owners and occupiers of lands abutting or immediately adjacent to the road notice of intention to make such a request.

Now therefore, His Excellency the Governor of the State of Victoria, by and with the advice of the Executive Council thereof, hereby directs:

- (a) that the said road which is shown by hatching and cross hatching on the plan hereunder shall be discontinued;

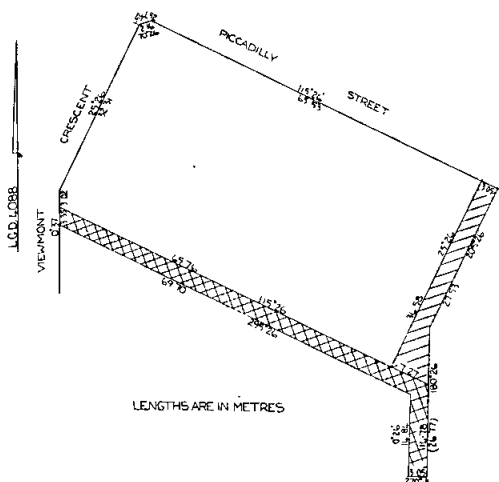

- (b) that notwithstanding such discontinuance the Geelong Waterworks and Sewerage Trust shall continue to have and possess the same right title power authority or interest in or in relation to the whole of the land shown by cross hatching on the said plan as it had or possessed prior to such discontinuance with respect to or in connection with any drains or pipes laid or erected in on or over such land for the purposes of drainage or sewerage;
- (c) that, subject to any such right title power authority or interest the land in the said road may be sold by the Council of the Shire of Corio by agreement.

And the Honourable Frank Noel Wilkes, Her Majesty's Minister for Local Government for the State of Victoria, shall give the necessary directions herein accordingly.

TOM FORRISTAL
Clerk of the Executive Council

LOCAL GOVERNMENT ACT 1958

At the Executive Council Chamber, Melbourne, the sixth day of September, 1983

Present:

His Excellency the Governor of Victoria
Mrs Toner | Mr Wilkes
Mr Jolly | Mr Kent

CONSENT TO SALE OF RESERVE BY THE OAKLEIGH CITY COUNCIL

Whereas certain land being the Reserve for Public Purposes on Plan of Subdivision No. 63811 lodged in the Office of Titles was transferred to the Council of the City of Oakleigh pursuant to the provisions of section 569B (8A)(a) of the *Local Government Act*

1958, and the said Council is now of the opinion that the land is no longer required for the purposes for which it was reserved and has requested that consent be given to the sale of that land.

- (a) has published in a newspaper generally circulating in the municipal district a notice describing the land and the proposal for the sale of the land and stating that at the next ordinary meeting of the Council after the expiration of forty days after publication of the notice the Council would consider any objections to the proposal and receive any representations as to the disposal of any purchase money;
- (b) being the registered proprietor of the land in question and there being no mortgagee chargee or lessee thereof has posted a similar notice upon the land.

And Whereas no objection has been made against the proposal and no representations have been made as to the disposal of any purchase money.

Now therefore, His Excellency the Governor of the State of Victoria, by and with the advice of the Executive Council thereof and in pursuance of the provisions of sub-section (2) of section 569BA of the *Local Government Act 1958* doth hereby consent to the Council of the City of Oakleigh selling by private treaty the Reserve for Public Purposes coloured green on Plan of Subdivision No. 63811 lodged in the Office of Titles.

And the Honourable Frank Noel Wilkes, Her Majesty's Minister for Local Government for the State of Victoria, shall give the necessary directions herein accordingly.

TOM FORRISTAL
Clerk of the Executive Council

LOCAL GOVERNMENT ACT 1958

At the Executive Council Chamber, Melbourne, the sixth day of September, 1983

Present:

His Excellency the Governor of Victoria	
Mrs Toner	Mr Wilkes
Mr Jolly	Mr Kent

VESTING OF A RESERVE IN THE FLINDERS SHIRE COUNCIL

Whereas it is provided by section 569BA of the *Local Government Act 1958*, that where any map or plan has been lodged or deposited with the Registrar of Titles pursuant to section 97 of the *Transfer of Land Act 1958*, or any corresponding previous enactment (whether before or after the commencement of the *Local Government Act 1963*) and any allotment on that map or plan has been transferred the Governor in Council on the request of the council of the municipality may by Order published in the Government Gazette direct that the whole or any part of the land comprised in any reserve shown on that map or plan shall vest in the council whereupon such land shall so vest freed and discharged from any mortgage charge lease or sub-lease;

And whereas the Council of the Shire of Flinders has requested that a reserve shown on plan of subdivision be vested in the Council and a lot on that plan has been transferred.

Now therefore, His Excellency, the Governor of the State of Victoria, by and with the advice of the Executive Council thereof and in pursuance of the provisions of sub-section 1 of section 569BA of the *Local Government Act 1958* doth by this Order vest in the Council of the Shire of Flinders the drainage and recreation reserve coloured purple on Plan of Subdivision No. 14581 lodged in the Office of Titles.

And the Honourable Frank Noel Wilkes, Her Majesty's Minister for Local Government for the State of Victoria, shall give the necessary directions herein accordingly.

TOM FORRISTAL
Clerk of the Executive Council

CROWN LAND (RESERVES) ACT 1978

At the Executive Council Chamber, Melbourne, the sixth day of September, 1983

Present:

His Excellency the Governor of Victoria	
Mrs Toner	Mr Wilkes
Mr Jolly	Mr Kent

REVOCAION OF TEMPORARY RESERVATIONS OF LANDS BY ORDERS IN COUNCIL

His Excellency the Governor of the State of Victoria, in the Commonwealth of Australia, by and with the advice of the Executive Council of the said State, pursuant to the provisions of section 10 of the *Crown Land (Reserves) Act 1978*, doth hereby revoke the temporary reservations of lands by Orders in Council hereinafter described, viz.:

BALNARRING — The temporary reservation by Order in Council of 16 June 1954 of 2.251 hectares, more or less, of land in the Parish of Balnarring (adjoining allotment 66A) for Supply of Gravel — (Rs.7252)

BALLARAT EAST — The temporary reservation by Order in Council of 16 January 1905 of 2496 square metres of land in the Township of Ballarat East (in section 53) for Drainage purposes, so far only as the portion thereof containing 920 square metres, more or less, as defined by description and hatching on plan published in the *Government Gazette* dated 17 August 1983, is concerned — (B128(41) (Rs.3771)

And the Honourable Roderick Alexander Mackenzie, Her Majesty's Minister for Conservation Forests and Lands for the State of Victoria, shall give the necessary directions herein accordingly.

TOM FORRISTAL
Clerk of the Executive Council

CROWN LAND (RESERVES) ACT 1978

At the Executive Council Chamber, Melbourne, the sixth day of September, 1983

Present:

His Excellency the Governor of Victoria	
Mrs Toner	Mr Wilkes
Mr Jolly	Mr Kent

CROWN LAND PERMANENTLY RESERVED

His Excellency the Governor of the State of Victoria, in the Commonwealth of Australia, by and with the advice of the Executive Council of the said State, pursuant to the provisions of sections 4 and 7 of the *Crown Land (Reserves) Act 1978*, and being of the opinion that the Crown land concerned is required for the purpose mentioned, doth hereby permanently reserve and also except from prospecting or from occupation for mining purposes under any miner's right, the Crown land hereinafter described, viz.:

Municipal District of the Shire of Wangaratta—

TARRAWINGEE—For Conservation of an Area of Natural Interest—10.58 hectares, being Crown allotment 13^B, section A, Parish of Tarrawingee, as shown on Certified Plan No. 106105 lodged in the Central Plan Office—(Parish 3560) (Rs.11365)

And the Honourable Roderick Alexander Mackenzie, Her Majesty's Minister for Conservation Forests and Lands for the State of Victoria, shall give the necessary directions herein accordingly.

TOM FORRISTAL
Clerk of the Executive Council

CROWN LAND (RESERVES) ACT 1978

At the Executive Council Chamber, Melbourne, the sixth day of September, 1983

Present:

His Excellency the Governor of Victoria

Mrs Toner	Mr Wilkes
Mr Jolly	Mr Kent

CROWN LANDS TEMPORARILY RESERVED

His Excellency the Governor of the State of Victoria, in the Commonwealth of Australia, by and with the advice of the Executive Council of the said State, pursuant to the provisions of sections 4 and 7 of the *Crown Land (Reserves) Act 1978* and being of the opinion that the Crown lands concerned are required for the purposes respectively mentioned, doth hereby temporarily reserve and also except from prospecting or from occupation for mining purposes under any miner's right, the Crown lands hereinafter described, viz.:

Municipal District of the City of Echuca—
 ECHUCA—For Public Recreation—7020 square metres, being Crown allotment 4, section 67, Township of Echuca, as indicated by hatching on plan hereunder—(E3(7) (Rs.5756).

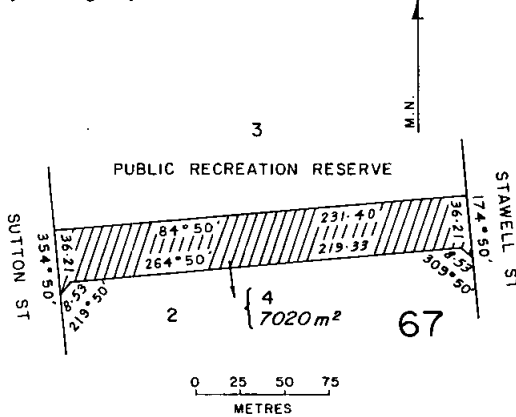

Municipal District of the Shire of Huntly—
 KAMAROOKA—For Public Hall—8094 square metres, being Crown allotment 88A, Parish of Kamarooka, as indicated by hatching on plan hereunder—(K14(2) (Rs.11246).

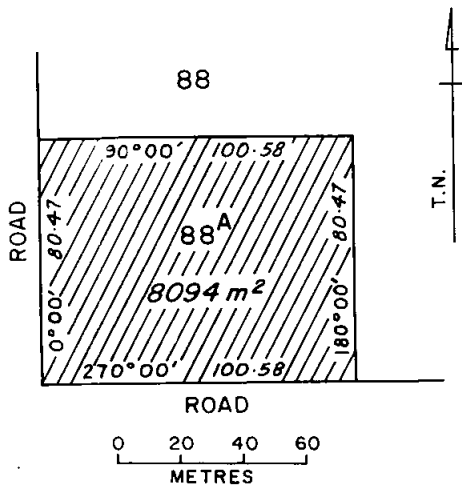

Municipal District of the Shire of Bulla—
 SUNBURY—For Public Recreation—1.770 hectares, being Crown allotment 2, section 3, Township of Sunbury, as shown on Certified Plan No. 103749 lodged in the Central Plan Office—(S351(6) (Rs.10222).

Municipal District of the Shire of Rodney—
 TATURA—For Public Recreation—6.637 hectares, being Crown allotment 2, section 25, Township of Tatura, as shown on Certified Plan No. 106400 lodged in the Central Plan Office—(Rs.1319).

Municipal District of the Shire of Bright—
 WERMATONG—For Supply of Gravel—5.401 hectares, being Crown allotment 9A, section 6, Parish of Wermatong, as shown on Certified Plan No. 106376 lodged in the Central Plan Office—(W350(3) (Rs.12511).

Municipal District of the Shire of Bright—
 WERMATONG—For Conservation of an Area of Natural Interest—7.6 hectares, more or less, being Crown allotments 9B and 9C, section 6, Parish of Wermatong, as shown on Certified Plan No. 106376 lodged in the Central Plan Office—(W350(3) (Rs.12510).

And the Honourable Roderick Alexander Mackenzie, Her Majesty's Minister for Conservation Forests and Lands for the State of Victoria, shall give the necessary directions herein accordingly.

TOM FORRISTAL
 Clerk of the Executive Council

CROWN LAND (RESERVES) ACT 1978

At the Executive Council Chamber, Melbourne, the sixth day of September, 1983

Present:

His Excellency the Governor of Victoria

Mrs Toner	Mr Wilkes
Mr Jolly	Mr Kent

CROWN LAND PLACED UNDER THE CONTROL AND MANAGEMENT OF THE MELBOURNE AND METROPOLITAN BOARD OF WORKS

His Excellency the Governor of the State of Victoria, in the Commonwealth of Australia, by and with the advice of the Executive Council of the said State, pursuant to the provisions of section 18(1) of the *Crown Land (Reserves) Act 1978*, doth hereby place under the control and management of the Melbourne and Metropolitan Board of Works, the Crown land hereinafter described, viz.:

TARNEIT—Land in the Parish of Tarneit, being Crown allotment 9B, section B, temporarily reserved for Sewerage purposes by Order in Council of 12 July 1983 (see *Government Gazette* dated 13 July 1983)—(Rs.12478)

And the Honourable Roderick Alexander Mackenzie, Her Majesty's Minister for Conservation Forests and Lands for the State of Victoria, shall give the necessary directions herein accordingly.

TOM FORRISTAL
 Clerk of the Executive Council

CROWN LAND (RESERVES) ACT 1978

At the Executive Council Chamber, Melbourne, the sixth day of September, 1983

Present:

His Excellency the Governor of Victoria
 Mrs Toner | Mr Wilkes
 Mr Jolly | Mr Kent

CROWN LANDS TEMPORARILY RESERVED

His Excellency the Governor of the State of Victoria, in the Commonwealth of Australia, by and with the advice of the Executive Council of the said State, pursuant to the provisions of sections 4 and 7 of the *Crown Land (Reserves) Act 1978*, and being of the opinion that the Crown lands concerned are required for the public purposes respectively mentioned, doth hereby temporarily reserve and also except from prospecting or from occupation for mining purposes under any miner's right, the Crown lands hereinafter described, viz.:

Municipal District of the Shire of Swan Hill—
 LAKE BOGA—For Community Centre—9596 square metres, being Crown allotment 34, Township of Lake Boga, as shown on Certified Plan No. 106533 lodged in the Central Plan Office—(L8(3) (Rs.12525).

Municipal District of the Shire of Morwell—
 MIRBOO—For Departmental Residence—943 square metres, being Crown allotment 9P, Parish of Mirboo, as indicated by hatching on plan hereunder—(M517(16) (Rs.8227).

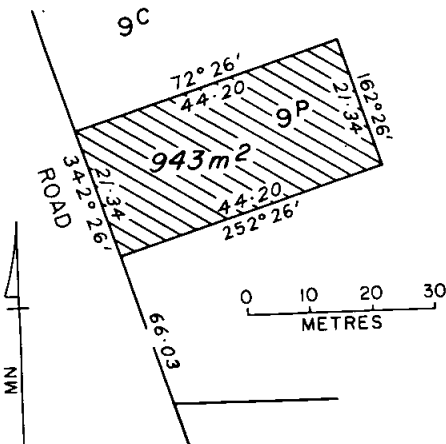

And the Honourable Roderick Alexander Mackenzie, Her Majesty's Minister for Conservation Forests and Lands for the State of Victoria, shall give the necessary directions herein accordingly.

TOM FORRISTAL
 Clerk of the Executive Council

CROWN LAND (RESERVES) ACT 1978

At the Executive Council Chamber, Melbourne, the sixth day of September, 1983

Present:

His Excellency the Governor of Victoria
 Mrs Toner | Mr Wilkes
 Mr Jolly | Mr Kent

CROWN LAND PERMANENTLY RESERVED

His Excellency the Governor of the State of Victoria, in the Commonwealth of Australia, by and with the advice of the Executive Council of the said State, pursuant to the provisions of

sections 4 and 7 of the *Crown Land (Reserves) Act 1978*, and being of the opinion that the Crown Land concerned is required for the purpose mentioned, doth hereby permanently reserve and also except from prospecting or from occupation for mining purposes under any miner's right, the Crown land hereinafter described, viz.:

Municipal District of the Shire of Hampden —

CORANGAMITE AND TAARAAK—For Management of Wildlife—80 hectares, more or less, being Crown allotments 40C and 40D, Parish of Corangamite, and 250 hectares, more or less, being Crown allotments 47C, 59C, 60C, 61C and 51C, Parish of Taarak, as indicated by hatching on plans hereunder — (C 296(4) (T 139(2) (Rs. 12163)

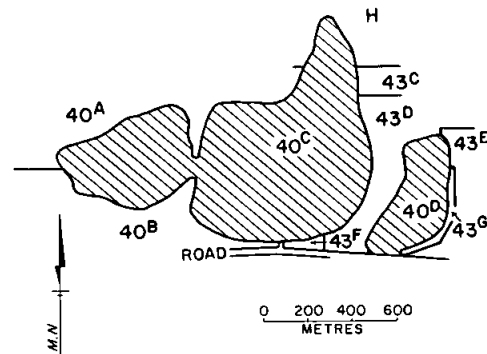
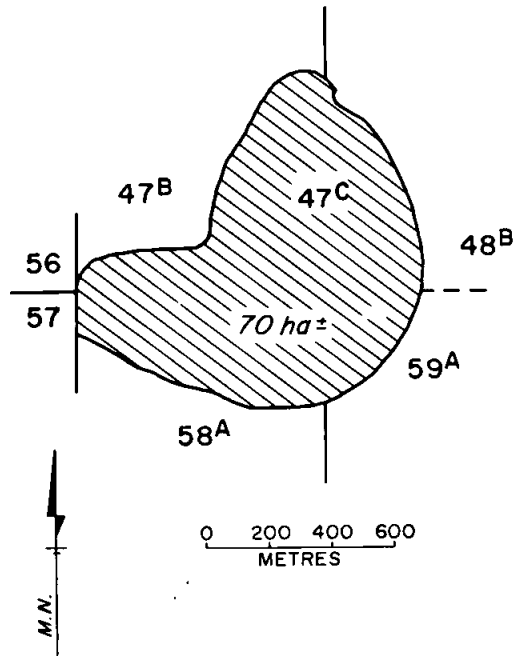

Total area of hatched portions 80 ha ±

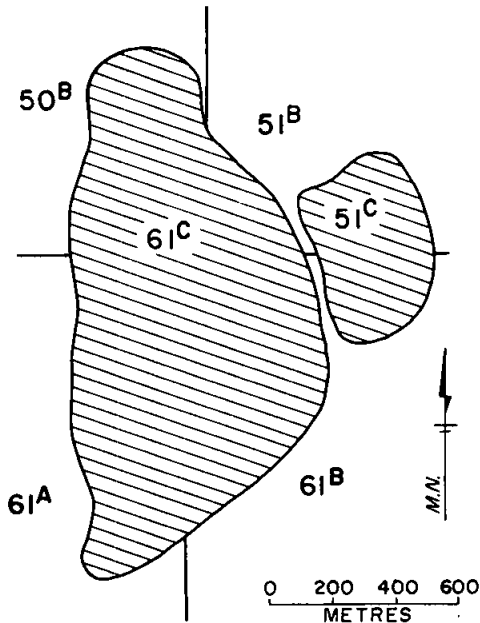

Total area of hatched portions 110 ha ± 49B

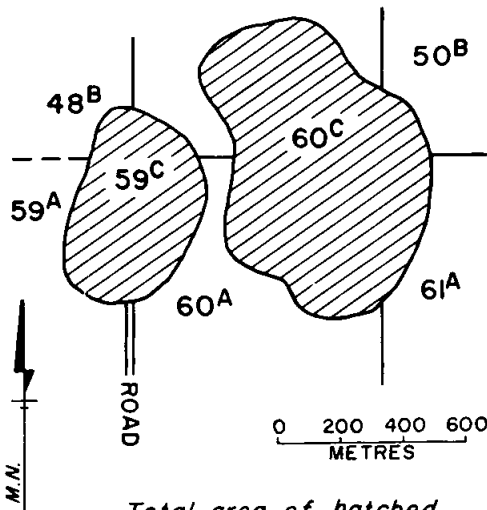

Total area of hatched portions 70 ha ±

And the Honourable Roderick Alexander Mackenzie, Her Majesty's Minister for Conservation Forests and Lands for the State of Victoria, shall give the necessary directions herein accordingly.

TOM FORRISTAL
Clerk of the Executive Council

CROWN LAND (RESERVES) ACT 1978

At the Executive Council Chamber, Melbourne, the sixth day of September, 1983

Present:

His Excellency the Governor of Victoria
Mrs Toner | Mr Wilkes
Mr Jolly | Mr Kent

CROWN LAND TEMPORARILY RESERVED

His Excellency the Governor of the State of Victoria, in the Commonwealth of Australia, by and with the advice of the Executive Council of the said State, pursuant to the provisions of sections 4 and 7 of the *Crown Land (Reserves) Act 1978*, and being of the opinion that the Crown land concerned is required for Public purposes, doth hereby temporarily reserve and also except from prospecting or from occupation for mining purposes under any miner's right, the Crown land hereinafter described, viz.:

Municipal District of the Shire of Swan Hill—

BUMBANG—For Public purposes — 3237 square metres, being Crown allotment 3H, section C, Parish of Bumbang, as indicated by hatching on plan hereunder — (B660(10) (Rs.5615)

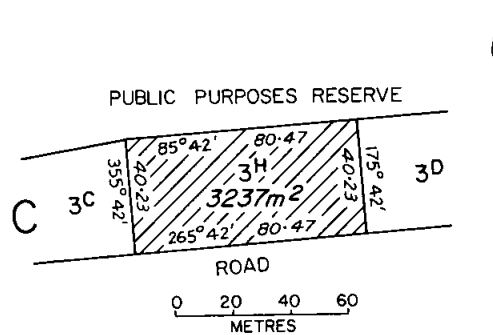

And the Honourable Roderick Alexander Mackenzie, Her Majesty's Minister for Conservation Forests and Lands for the State of Victoria, shall give the necessary directions herein accordingly.

TOM FORRISTAL
Clerk of the Executive Council

CROWN LAND (RESERVES) ACT 1978

At the Executive Council Chamber, Melbourne, the sixth day of September, 1983

Present:

His Excellency the Governor of Victoria
Mrs Toner | Mr Wilkes
Mr Jolly | Mr Kent

CROWN LAND TEMPORARILY RESERVED FOR THE ADDITIONAL PURPOSE OF PUBLIC RECREATION

His Excellency the Governor of the State of Victoria, in the Commonwealth of Australia, by and with the advice of the Executive Council of the said State, pursuant to the provisions of section 4 of the *Crown Land (Reserves) Act 1978*, and being of the opinion that the Crown land concerned is required for the additional purpose of Public Recreation, doth hereby temporarily reserve the Crown land hereinafter described for the said additional purpose, viz.:

Municipal District of the Shire of Bright—

HARRIETVILLE—For Public Recreation — 4.586 hectares, being Crown allotment 7, section E, Township of Harrietville and

being the remaining portion of the land temporarily reserved for Camping purposes by Order in Council of 13 March 1968 (see Government Gazette dated 20 March 1968), as indicated by hatching on plan hereunder — (H125(6) (Rs.3617).

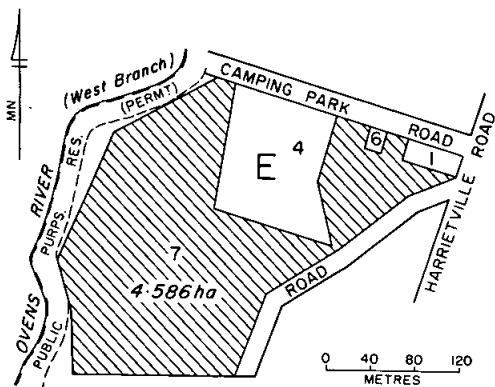

And the Honourable Roderick Alexander Mackenzie, Her Majesty's Minister for Conservation Forests and Lands for the State of Victoria, shall give the necessary directions herein accordingly.

TOM FORRISTAL
Clerk of the Executive Council

HOUSING ACT 1958

At the Executive Council Chamber, Melbourne, the sixth day of September, 1983

Present:

His Excellency the Governor of Victoria

Mrs Toner	Mr Wilkes
Mr Jolly	Mr Kent

DECLARATION OF PRIVATE STREETS AS PUBLIC HIGHWAYS WITHIN THE SHIRE OF MORWELL

Whereas pursuant to Section 107 of the *Housing Act 1958* it is among other things enacted that where works have been carried out in accordance with an agreement for the full construction of any roads, pavements, culverts or drains made pursuant to the provisions of the said Section 107 such roads, pavements, culverts or drains shall be under the care and management of the Municipality which shall be liable for the cost of any maintenance, repair, alteration or reconstruction thereof and the Governor in Council may by order published in the *Government Gazette* declare any road so constructed to be a public highway.

And whereas by Order dated 1 July 1980, the Governor in Council consented to an agreement regarding street and drainage construction in Keats Court, Symons Court and part Vary Street in the Morwell-Vary Street Estate situated in the municipality of the Shire of Morwell and the carrying out of the works enumerated in the said Agreement.

And whereas the works of road pavements, culvert and drainage construction have now been carried out in accordance with the said Agreement between the Housing Commission and the Shire of Morwell.

Now therefore His Excellency the Governor of the State of Victoria by and with the advice of the Executive Council of the said State and in pursuance of the powers conferred by Section 107 of the *Housing Act* and upon recommendation of the Housing Commission doth by this order declare the streets more particularly delineated and shown hatched on the plan hereunder to be absolutely dedicated to the public as Public Highways within the

meaning of any law now or hereafter in force and that the Council of the Municipality in which the streets are situate shall hereafter be liable for all cost of any maintenance, repair, alteration or reconstruction thereof.

PART OF CROWN ALLOTMENT 74

PARISH OF MARYVALE

COUNTY OF BULN BULN

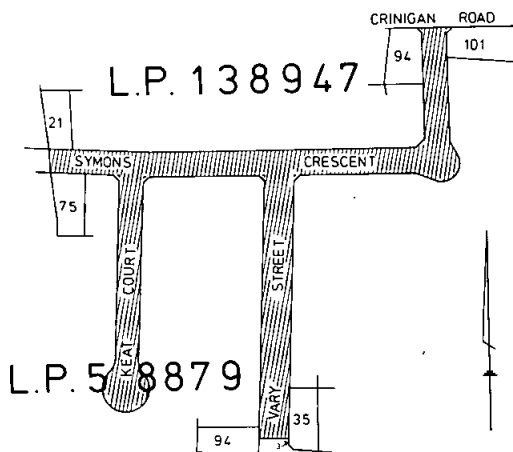
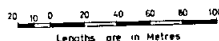

And the Honourable Ian Robert Cathie, Her Majesty's Minister of Housing for the State of Victoria, shall give the necessary directions herein accordingly.

TOM FORRISTAL
Clerk of the Executive Council

FIRST MILDURA IRRIGATION TRUST
MILDURA URBAN WATER TRUST

At the Executive Council Chamber, Melbourne, the sixth day of September, 1983

Present:

His Excellency the Governor of Victoria

Mrs Toner	Mr Wilkes
Mr Jolly	Mr Kent

SEVERANCE OF A PORTION OF THE FIRST MILDURA IRRIGATION TRUST DISTRICT AND ANNEXATION TO THE MILDURA URBAN WATER TRUST DISTRICT

Under the powers conferred by the Mildura Irrigation and Water Trusts Act and all other powers enabling him in that behalf, His Excellency the Governor of the State of Victoria, by and with the advice of the Executive Council of the said State, doth hereby declare, order and direct that as on and from the date hereof the land shown by red colour on the plan approved by the Governor in Council and deposited in the office of the State Rivers and Water Supply Commission, Melbourne (Corr. No. 80/4325/55) shall be severed from the District of the First Mildura Irrigation Trust and annexed to the District of the Mildura Urban Water Trust.

And the Honourable David Ronald White, Her Majesty's Minister of Water Supply for the State of Victoria, shall give the necessary directions herein accordingly.

TOM FORRISTAL
Clerk of the Executive Council

SHIRE OF BACCHUS MARSH LOCAL GOVERNING BODY

*At the Executive Council Chamber, Melbourne, the
sixth day of September, 1983*

Present:

His Excellency the Governor of Victoria	
Mrs Toner	Mr Wilkes
Mr Jolly	Mr Kent

EXTENT OF WATER SUPPLY DISTRICT INCREASED

Under the powers conferred by the Water Act and all other powers enabling him in that behalf, His Excellency the Governor of the State of Victoria, by and with the advice of the Executive Council of the said State, doth hereby declare, order and direct that the extent of the Water Supply District of the Shire of Bacchus Marsh Local Governing Body be increased by adding thereto the lands shown by red colour on the plan approved by the Governor in Council, by and with this Order and deposited in the Office of the State Rivers and Water Supply Commission, Melbourne (Corr. No. 81/2459/70) and as on and from the date hereof such above-mentioned alterations shall be and be deemed to be approved accordingly.

And the Honourable David Ronald White, Her Majesty's Minister of Water Supply for the State of Victoria, shall give the necessary directions herein accordingly.

TOM FORRISTAL
Clerk of the Executive Council

SHIRE OF BACCHUS MARSH LOCAL GOVERNING BODY

*At the Executive Council Chamber, Melbourne, the
sixth day of September, 1983*

Present:

His Excellency the Governor of Victoria	
Mrs Toner	Mr Wilkes
Mr Jolly	Mr Kent

EXTENT OF WATER SUPPLY DISTRICT INCREASED
SITE OF PIPELINE APPROVED

Under the powers conferred by the Water Act and all other powers enabling him in that behalf, His Excellency the Governor of the State of Victoria, by and with the advice of the Executive Council of the said State, doth hereby declare, order and direct that the extent of the Water Supply District of the Shire of Bacchus Marsh Local Governing Body be increased by adding thereto the lands shown by red colour and also approves of the site of works for a pipeline as shown by orange line on the plan approved by the Governor in Council, by and with this Order and deposited in the Office of the State Rivers and Water Supply Commission, Melbourne (Corr. No. 81/2459/71) and as on and from the date hereof such above-mentioned alterations shall be and be deemed to be approved accordingly.

And the Honourable David Ronald White, Her Majesty's Minister of Water Supply for the State of Victoria, shall give the necessary directions herein accordingly.

TOM FORRISTAL
Clerk of the Executive Council

HOSPITALS AND CHARITIES ACT 1958
SECTION 43B

*At the Executive Council Chamber, Melbourne, the
sixth day of September, 1983*

Present:

His Excellency the Governor of Victoria	
Mrs Toner	Mr Wilkes
Mr Jolly	Mr Kent

Whereas by Section 43B of the *Hospitals and Charities Act* 1958 (hereinafter referred to as the "Act") a scheduled hospital may enter into agreements with a benevolent society or institution established to undertake the relief of aged, disabled or handicapped persons.

And whereas any such agreement may, amongst other things, provide for the appointment, transfer or retention of any property, income, assets, rights or liabilities vested in the hospital.

And whereas any such agreement shall not be given effect to until approved by the Governor in Council.

And whereas St. Arnaud District Hospital is a scheduled hospital within the meaning of the Act.

And whereas St. Arnaud Elderly Persons Hostel Society is a benevolent society within the meaning of the Act established to undertake the relief of aged, disabled or handicapped persons.

And whereas St. Arnaud District Hospital has entered into an agreement with St. Arnaud Elderly Persons Hostel Society for the transfer of the sum of Fifty Thousand Dollars (\$50,000) from the Hospital to the Society towards the cost of erection of a proposed Hostel for the relief of aged, disabled or handicapped persons.

Now therefore His Excellency the Governor of the State of Victoria, by and with the advice of the Executive Council of the said State, doth by this Order approve of the agreement entered into between St. Arnaud District Hospital and St. Arnaud Elderly Persons Hostel Society for the transfer of the said funds from the Hospital to the Society.

And the Honourable Thomas William Roper, Her Majesty's Minister of Health for the State of Victoria, shall give the necessary directions herein accordingly.

TOM FORRISTAL
Clerk of the Executive Council

VICTORIAN INSTITUTE OF MARINE SCIENCES ACT 1974

*At the Executive Council Chamber, Melbourne, the
sixth day of September, 1983*

Present:

His Excellency the Governor of Victoria	
Mrs Toner	Mr Wilkes
Mr Jolly	Mr Kent

Appointment of a member to fill a casual vacancy on the Council of the Victorian Institute of Marine Sciences.

In pursuance of the powers conferred by the provisions of Section 9 (5) of the *Victorian Institute of Marine Sciences Act* 1974, and all other powers him thereunto enabling, His Excellency the Governor of the State of Victoria, by and with the advice of the Executive Council thereof, doth by this Order appoint Peter J. Hanna to be a member of the Council of the Victorian Institute of Marine Sciences during the period ending 2 March 1984, being the residue of the term of R. Nelson as the nominee of the Council of Deakin University.

And the Honourable Evan Walker, Her Majesty's Minister for Conservation for the State of Victoria, shall give the necessary directions herein accordingly.

TOM FORRISTAL
Clerk of the Executive Council

URBAN RENEWAL ACT 1970

At the Executive Council Chamber, Melbourne, the sixth day of September, 1983

Present:

His Excellency the Governor of Victoria	
Mrs Toner	Mr Wilkes
Mr Jolly	Mr Kent

TERMINATION OF THE PREPARATION AND IMPLEMENTATION OF URBAN RENEWAL PROPOSALS

Pursuant to the powers conferred by Section 4(6) and 8A(3) of the *Urban Renewal Act 1970* and all other powers therein enabling, His Excellency the Governor of the State of Victoria, by and with the advice of the Executive Council thereof, doth by this order direct that the preparation and implementation of the undermentioned urban renewal proposals by the Housing Commission be terminated in respect of the areas indicated in the Schedule hereunder, as from the date of the Order.

Schedule

Municipality in which preparation of proposal shall cease — City of Kew.

Municipality in which implementation of proposal shall cease — Shire of Woorayl (Leongatha).

Urban Renewal Area — As defined on the Maps lodged with the offices of the municipalities listed and the Housing Commission.

And the Honourable Ian Robert Cathie, Her Majesty's Minister of Housing for the State of Victoria, shall give the necessary directions herein accordingly.

TOM FORRISTAL
Clerk of the Executive Council

POST-SECONDARY EDUCATION (AMENDMENT) ACT
No. 9933

At the Executive Council Chamber, Melbourne, the sixth day of September, 1983

Present:

His Excellency the Governor of Victoria	
Mrs Toner	Mr Wilkes
Mr Jolly	Mr Kent

Whereas sub-section 1 of Section 122 of the *Post-Secondary Education (Amendment) Act No. 9933* provides that the Governor-in-Council may, on the recommendation of the Minister appoint eight persons to the Technical and Further Education Accreditation Board.

And whereas sub-section 3 of Section 122 of the said Act provides that the Governor-in-Council may appoint one member of the Technical and Further Education Board as its chairman and another as its deputy chairman.

And whereas the Minister has recommended—

Brian N. R. Clarke
Peter F. Furniss
Robert W. Grose
Brian E. Lloyd (Chairman)
William Roebuck
Malcolm Swaine (Deputy-Chairman)
Raymond H. Way

Now therefore, His Excellency the Governor of the State of Victoria by and with the advice of the Executive Council thereof and on the recommendation of the Minister doth hereby appoint the above-mentioned persons to the Technical and Further Accreditation Board and further, appoints —

Brian E. Lloyd as Chairman and
Malcolm Swaine as Deputy Chairman of the said Board.

And the Honourable Robert Clive Fordham, Her Majesty's Minister of Education for the State of Victoria, shall give the necessary directions herein accordingly.

TOM FORRISTAL
Clerk of the Executive Council

EDUCATION ACT 1958

At the Executive Council Chamber, Melbourne, the thirteenth day of September, 1983

Present:

His Excellency the Governor of Victoria	
Mr Trezise	Mr Spyker

AMENDMENT TO THE CONSTITUTION OF COUNCIL OF GIPPSLAND INSTITUTE OF ADVANCED EDUCATION

Whereas the Governor in Council has pursuant to sub-section 1 of Section 29A of the Education Act made an Order which was published in the *Government Gazette* of 25 September 1968, and which amongst other matters constituted a council by the name of "Council of the Yallourn Technical College":

And whereas the Governor in Council by a subsequent Order published in the *Government Gazette* of 1 July 1970, changed such name to "Council of the Gippsland Institute of Advanced Education":

And whereas the Governor in Council by a subsequent Order published in the *Government Gazette* of 21 February 1973, amended the provisions of the Order published in the *Government Gazette* of 25 September 1968:

And whereas sub-section 5 of Section 29A of the *Education Act 1958* provides that the Governor in Council after the making of an Order pursuant to sub-section 1 of Section 29A of the Act may on the recommendation of the Minister made after consulting the council of the institution concerned by any subsequent Order make further provision for or with respect to the membership powers duties and functions of the Council or amend or vary any such provisions of a previous order:

And whereas the Minister has consulted the Council of the Gippsland Institute of Advanced Education:

Now therefore, His Excellency the Governor of the State of Victoria, by and with the advice of the Executive Council thereof, and on the recommendation of the Minister does by this Order amend the provisions of the said Order published in the *Government Gazette* of 21 February 1973, to provide as follows:

In sub-section (1) of section 2, for the expression "twenty-three" there shall be substituted the expression "twenty-four".

After sub-section (1) (h) of Section 2 there shall be added the following sub-section:

"(i) One shall be a member of the full-time general staff of the College elected by the full-time general staff from among their number in a manner determined by the Council."

And the Honourable Robert Clive Fordham, Her Majesty's Minister of Education for the State of Victoria, shall give the necessary directions herein accordingly.

TOM FORRISTAL
Clerk of the Executive Council

WATER ACT 1958

At the Executive Council Chamber, Melbourne, the
thirteenth day of September, 1983

Present:

His Excellency the Governor of Victoria

Mr Trezise

Mr Spyker

**SHEPPARTON URBAN WATERWORKS TRUST —
EXTENT OF WATERWORKS DISTRICT AND AREA OF
SHEPPARTON URBAN DISTRICT INCREASED**

Under the powers conferred by the *Water Act 1958* and all other powers enabling him in that behalf, His Excellency the Governor of the State of Victoria, with the advice of the Executive Council of the said State, doth hereby declare, order and direct that the extent of the Waterworks District of the Shepparton Urban Waterworks Trust and the area of the Shepparton Urban District of the said Trust be increased by adding to the said Districts the land shown by blue colour on a plan approved by the Governor in Council and deposited in the office of the State Rivers and Water Supply Commission at 590 Orrong Road, Armadale, (Corr. No. 78/980) and as on and from the 1st day of October, 1983, the extent of the said Waterworks District and the area of the said Urban District shall be deemed to be so increased.

And the Honourable David Ronald White, Her Majesty's Minister of Water Supply for the State of Victoria, shall give the necessary directions herein accordingly.

TOM FORRISTAL
Clerk of the Executive Council

**WATER ACT 1958
STATE RIVERS AND WATER SUPPLY COMMISSION**

At the Executive Council Chamber, Melbourne, the
thirteenth day of September, 1983

Present:

His Excellency the Governor of Victoria

Mr Trezise

Mr Spyker

**GOULBURN-MURRAY IRRIGATION DISTRICT —
PORTION EXCISED
SHEPPARTON IRRIGATION AREA — BOUNDARIES
VARIED**

Under the powers conferred by the *Water Act 1958* and all other powers enabling him in that behalf, His Excellency the Governor of the State of Victoria, with the advice of Executive Council of the said State, on the recommendation of the State Rivers and Water Supply Commission, doth hereby declare order and direct that there shall be excised from the Goulburn-Murray Irrigation District the land shown by green colour on a plan approved by the Governor in Council and deposited in the office of the State Rivers and Water Supply Commission at 590 Orrong Road, Armadale, (Corr. No. 78/980) and that the boundaries of the Shepparton Irrigation Area shall be varied to excise therefrom such land which shall be deemed to be excised from the said Irrigation District and Irrigation Area as on and from 30 September 1983.

And the Honourable David Ronald White, Her Majesty's Minister of Water Supply for the State of Victoria, shall give the necessary directions herein accordingly.

TOM FORRISTAL
Clerk of the Executive Council

**LANDS DEPARTMENT
NOTICES**

APPROACHING LAND SALES

Sale of Crown Land, will be held at the under-mentioned places and dates, viz.:

	No. of Gazette
Castlemaine—Monday, 17 October 1983	81
Hamilton—Wednesday, 9 November 1983	86
Rochester—Monday, 10 October 1983	80
Underbool—Friday, 30 September 1983	81
Vermont—Saturday, 24 September 1983	78

SALE OF CROWN LANDS BY AUCTION

The land will be offered for sale subject to the provisions of the Land Act and Regulations thereunder.

The upset price is the sum at which bidding will start, and no bid below that sum can be accepted. The highest bidder at or above that sum shall be the purchaser, subject to signature of contract and any necessary payment.

Terms

A deposit of at least 12½ per cent of the purchase price must be paid at the sale, either in cash or by cheque.

The residue is payable on _____ or may be paid off at any earlier time.

Interest at the rate of 14 per cent per annum is payable on arrears after the due date.

Fees, etc.

Payable with balance of purchase money — Crown Grant fee — \$41.00.

Assurance contribution — one cent in every Five dollars or part thereof of purchase price (this is to guarantee the validity of the Crown Grant).

Transfer of interest prior to completion of payment may be allowed on payment of the prescribed fee and subject to stamp duty.

If unable to attend personally a prospective purchaser may arrange for another person to bid as his agent.

Attention is drawn to Section 95, *Land Act 1958*, which provides that the purchaser shall be deemed to be the owner for the purposes of other Acts; also to an amendment to the Local Government Act providing for Government roads, in certain circumstances, to be declared "private streets", thus making the purchaser liable to contribute to the cost of street construction.

R. A. MACKENZIE
Minister for Conservation
Forests and Lands

Department of Crown Lands and Survey
Melbourne

HATTAH — Sale (No. 12402) of Crown land, by auction, will be held on site, corner Calder and Murray Valley Highways, Hattah on Tuesday 29 November 1983 at 11.00 a.m. To be conducted by P. J. Richardson, Regional Land Officer, Mildura.

Lot 1 — Parish of Mournpoul — adjacent to the store at Hattah. Upset price \$1800.00 the lot. Area 1.8 hectares more or less. Allotment 21^E.

Special condition — Pipeline easement 4.83 metres wide.

Enquiries — Regional Land Office, Mildura. Phone (050) 23 2543, — (L5-1360).

**PROPOSED REVOCATION OF TEMPORARY
RESERVATION OF LAND BY ORDER IN COUNCIL**

In pursuance of the provisions of Section 10 of the *Crown Land (Reserves) Act 1978*, notice is hereby given that it is the intention of the Governor in Council to revoke the temporary reservation of land by Order in Council hereunder referred to, viz.:

WERRIBEE—The temporary reservation for Railway purposes by Order in Council of 18 April 1864 of 5·600 hectares of land in the Township of Werribee (called Parish of Mambourin in Order) — (Rs.12527).

ELDORADO—The temporary reservation for State School purposes and the withholding from sale, leasing and licensing by Order in Council of 29 December 1874 of 2·023 hectares of land in the Parish of Eldorado (called Parish of Beechworth in Order) (in Section 10) — (L8-3037).

BULLAROOK—The temporary reservation by Order in Council of 15 May 1956 of 4047 square metres of land in the Parish of Bullarook (in Section B) for Public Recreation — (Rs.1445).

R. A. MACKENZIE
Minister for Conservation
Forests and Lands

Department of Crown Lands and Survey
Melbourne

TENDERS

PUBLIC WORKS DEPARTMENT

Tenders are invited for the purposes indicated hereunder and will be received at 2 Treasury Place, Melbourne, 3002, until **TWO** p.m. on dates shown.

Tenders must be addressed to the Minister of Public Works with the envelope endorsed "Tender for".

Hand-delivered tenders must be placed in the Department's tender box in foyer, Ground Floor, 2 Treasury Place, Melbourne.

Tenders documents are available from the Contracts Office, Room 29, 2 Treasury Place, Melbourne and where indicated, at offices of Inspectors of Works.

* Tenders for works identified with star (*) will only be considered from Contractors qualified for repairs and painting works. Any Tenderers wishing to qualify may obtain the application form from the Contracts Office.

Wednesday, 21 September 1983

Miscellaneous

MELBOURNE—Supply screens—T1253/21/9, Corporate Affairs Office—471 Little Bourke Street.

Wednesday, 28 September 1983

Building, Electrical and Mechanical Services

* **ALTONA EAST**—Internal and external repairs, Primary School.

* **BAL WYN**—(Re-advertised and amended)—Internal repairs and painting and roof repairs to nurses quarters, St. Gabriels Hospital.

* **BENDIGO EAST**—External repairs and painting—Primary School. (W.O. Bendigo.)

INVERLOCH—Relocatable complex, siting of relocatables and construction of gallery and demolition work, Primary School. (W.O. Korumburra.)

MELBOURNE—Alterations to 1st Floor, County Court Building, 223 William Street, Law Department.

MELBOURNE—Machining of sandstone, State Library/Science Museum, Ministry for the Arts.

WARRNAMBOOL—Replacement of locks, Brierly Mental Hospital. (W.O. Warrnambool and Geelong.)

Miscellaneous

BLACK ROCK—Armour Rock wall south side of Black Rock Yacht Club, Half Moon Bay—Ports and Harbors Division.

CHILTERN—Maintenance cleaning, Police Station—Police and Emergency Services. (Police Station, Chiltern.)

CORRYONG—Maintenance cleaning, Police Station—Police and Emergency Services. (Police Station, Corryong.)

CROYDON NORTH—Maintenance cleaning, Upper Yarra Valley and Dandenong Ranges Authority Office, Old Melbourne Road. (Office, Upper Yarra Valley and Dandenong Ranges Authority.)

FRANKSTON—Maintenance cleaning, 30-44 Young Street—Community Welfare Services. (Police Station, Frankston.)

KYNETON—Maintenance cleaning, Public Offices. (W.O. Kyneton.)

MELBOURNE—Maintenance cleaning, Police Station, 380 William Street—Police and Emergency Services.

PORT MELBOURNE—Supply of coir mats, P.W.D. Storeyard, 69 Salmon Street.

RUSHWORTH—Maintenance cleaning, Police Station—Police and Emergency Services. (Police Station, Rushworth.)

Wednesday, 5 October 1983

Building, Electrical and Mechanical Services

MITCHAM—Intruder Detection System, Primary School.

MITCHAM—Intruder Detection System, High School.

MOOMBA PARK—Upgrade of students toilets, Primary School.

MORWELL—Internal renovations including air conditioning, Police Station. (W.O. Traralgon.)

PARKVILLE—Lighting facilities to various buildings, Turana Youth Training Centre.

SHEPPARTON—Intruder Detection System, Primary School.

* **SPRINGVALE WEST**—(Re-advertised and amended)—External repairs and painting, internal toilet repairs and painting, Primary School.

SUNBURY—Provision of new roof to existing library building, High School.

Siteworks

WESTMEADOWS—New asphalt road, Police Driving School. Police and Emergency Services.

EVAN WALKER, M.P.
Minister of Public Works

Public Works Department
Melbourne, 13 September 1983

LATE NOTICES

BANK HOLIDAYS ACT 1958

**ALTERATION OF DAY APPOINTED AS A BANK
HOLIDAY**

PROCLAMATION

By His Excellency the Governor of the State of Victoria and its Dependencies in the Commonwealth of Australia, &c., &c., &c.

Whereas by section 4 of the *Bank Holidays Act 1958*, the last Thursday in September shall be observed as a bank holiday throughout the municipalities listed in the Second Schedule to the said Act:

And whereas it is made to appear to the Governor in Council expedient that the said day should not be a bank holiday throughout the said municipalities:

Now therefore I, the Governor of the State of Victoria, in the Commonwealth of Australia, by and with the advice of the Executive Council of the said State, and in pursuance of the powers conferred by sections 5 and 7 of the *Bank Holidays Act 1958*, do by this my Proclamation—

1. declare that the said day shall not be a bank holiday throughout the said municipalities; and

2. appoint Thursday, 22 September 1983 to be a bank holiday throughout the municipalities specified hereunder:

Cities:

Altona	Kew
Berwick	Knox
Box Hill	Malvern
Brighton	Melbourne
Broadmeadows	Moorabbin
Brunswick	Mordialloc
Camberwell	Northcote
Caulfield	Nunawading
Chelsea	Oakleigh
Coburg	Port Melbourne
Collingwood	Prahran
Croydon	Preston
Dandenong	Richmond
Doncaster and Templestowe	Ringwood
Essendon	St Kilda
Fitzroy	Sandringham
Footscray	South Melbourne
Frankston	Springvale
Hawthorn	Sunshine
Heidelberg	Waverley
Keilor	Williamstown

Shires:

Bacchus Marsh
Bulla
Cranbourne
Diamond Valley
Eltham
Hastings
Lillydale
Melton
Mornington
Pakenham
Romsey (except for the Townships of Romsey and Lancefield)
Sherbrooke
Werribee
Whittlesea

Given under my Hand and the Seal of the State of Victoria aforesaid, at Melbourne, this thirteenth day of September, in the year of our Lord One thousand nine hundred and eighty-three, and in the thirty-second year of the reign of Her Majesty Elizabeth the Second, Queen of Australia.

(L.S.)

BRIAN MURRAY

By His Excellency's Command,

S. M. CRABB

Minister of Labour and Industry

GOD SAVE THE QUEEN!

PUBLIC SERVICE ACT 1974

PUBLIC HOLIDAYS

PROCLAMATION

By His Excellency the Governor of the State of Victoria and its Dependencies in the Commonwealth of Australia, &c., &c., &c.

In pursuance of the provisions contained in Section 71 (2) of the *Public Service Act 1974*, I, the Governor of the State of Victoria, in the Commonwealth of Australia, by and with the advice of the Executive Council of the said State, do by this my Proclamation appoint the days and dates mentioned hereunder to be observed as Public Holidays or Public Half-Holidays (as the case may be) at the places respectively specified:

Public Holidays

Thursday, 22 September 1983 throughout the Wallan Riding within the Shire of Kilmore.

Thursday, 6 October 1983 within the Shire of Warracknabeal.

Friday, 7 October 1983 throughout the Shire of Shepparton.

Wednesday, 12 October 1983 in that part of the Shire of Walpeup, westerly from the Township of Linga to the Shire of Boundary.

Tuesday, 18 October 1983 within the Shire of Karkaroc.

Wednesday, 19 October 1983 within the City of Geelong.

Public Half-Holidays from the Hour of Twelve noon

Tuesday, 4 October 1983 throughout the Borough of Kerang.

Tuesday, 4 October 1983 within the Shire of Kerang.

Wednesday, 5 October 1983 within the Shire of Cranbourne.

Monday, 10 October 1983 within the Shire of Birchip.

Tuesday, 11 October 1983 throughout the North Riding of the Shire of Dimboola.

Wednesday, 12 October 1983 throughout the Centre Riding of the Shire of Dimboola.

Wednesday, 12 October 1983 throughout the North and Tyrrell Ridings of the Shire of Wycheproof.

Thursday, 13 October 1983 within the Shire of Lowan.

Friday, 14 October 1983 within the City of Echuca.

Wednesday, 19 October 1983 throughout the South and Central Ridings of the Shire of Wycheproof.

Given under my Hand and the Seal of the State of Victoria aforesaid, at Melbourne, this thirteenth day of September in the year of our Lord One thousand nine hundred and eighty-three and in the thirty-second year of the reign of Her Majesty Elizabeth the Second, Queen of Australia.

(L.S.)

BRIAN MURRAY

By His Excellency's Command,

S. M. CRABB

Minister of Labour and Industry

GOD SAVE THE QUEEN!

BANK HOLIDAYS ACT 1958

BANK HOLIDAYS

PROCLAMATION

By His Excellency the Governor of the State of Victoria and its Dependencies in the Commonwealth of Australia, &c., &c., &c.

In pursuance of the provisions of the *Bank Holidays Act 1958*, I, the Governor of the State of Victoria, in the Commonwealth of Australia, do by this my Proclamation appoint the days and dates mentioned hereunder as special days to be observed as Bank Holidays or Bank Half-Holidays (as the case may be) at the places respectively specified:

Bank Holidays

Monday, 19 September 1983 at Romsey and Lancefield within the Shire of Romsey.

Thursday, 6 October 1983 within the Shire of Warracknabeal.

Friday, 7 October 1983 within the City of Shepparton.

Thursday, 13 October 1983 throughout the Township of Nhili within the Shire of Lowan.

Wednesday, 19 October 1983 at Geelong, Geelong West, North Geelong and East Geelong within the City of Geelong.

Wednesday, 19 October 1983 at Belmont, Grovedale and High-ton within the City of South Barwon.

Wednesday, 19 October 1983 at Lara and Norlane within the Shire of Corio.

Wednesday, 19 October 1983 at Newcomb and Whittington within the Shire of Bellarine.

Tuesday, 1 November 1983 within the Shire of Avoca.

Tuesday, 1 November 1983 at Healesville and Yarra Glen within the Shire of Healesville.

Wednesday, 2 November 1983 within the Shire of Kyneton.

Bank Half-Holidays from the Hour of Eleven a.m.

Wednesday, 14 September 1983 within the Shire of Kilmore.

Monday, 24 October 1983 throughout the Shire of Kilmore.

Tuesday, 1 November 1983 at Wedderburn within the Shire of Korong.

Given under my Hand and the Seal of the State of Victoria aforesaid, at Melbourne, this thirteenth day of September in the year of our Lord One thousand nine hundred and eighty-three and in the thirty-second year of the reign of Her Majesty Elizabeth the Second, Queen of Australia.

(L.S.)

BRIAN MURRAY

By His Excellency's Command,

S. M. CRABB

Minister of Labour and Industry

GOD SAVE THE QUEEN!

PUBLIC SERVICE ACT 1974
ALTERATION OF DAY APPOINTED AS A PUBLIC
HOLIDAY

PROCLAMATION

By His Excellency the Governor of the State of Victoria and its Dependencies in the Commonwealth of Australia, &c., &c., &c.

Whereas by section 71 of the *Public Service Act 1974*, the fourth Thursday in September shall be observed as a public holiday throughout the municipalities listed in the Fifth Schedule to the said Act:

And whereas it is made to appear to the Governor in Council expedient that the said day should not be a public holiday throughout the Shires of Bacchus Marsh, Gisborne and Romsey:

Now therefore I, the Governor of the State of Victoria, in the Commonwealth of Australia, by and with the advice of the Executive Council of the said State, and in pursuance of the powers conferred by section 71 of the *Public Service Act 1974*, do by this my Proclamation declare that the said day shall not be a public holiday throughout the Shires of Bacchus Marsh, Gisborne and Romsey.

Given under my Hand and the Seal of the State of Victoria aforesaid, at Melbourne, this thirteenth day of September, in the year of our Lord One thousand nine hundred and eighty-three, and in the thirty-second year of the reign of Her Majesty Elizabeth the Second, Queen of Australia.

(L.S.)

BRIAN MURRAY

By His Excellency's Command,

S. M. CRABB

Minister of Labour and Industry

GOD SAVE THE QUEEN!

ACTS OF PARLIAMENT

PROCLAMATION

By His Excellency the Governor of the State of Victoria and its Dependencies in the Commonwealth of Australia, &c., &c., &c.

I, the Governor of the State of Victoria, in the Commonwealth of Australia, do hereby declare that I have this day assented, in Her Majesty's name, to the Bills passed by the Parliament of the

said State, the titles whereof are hereunder set forth, together with the short titles, that is to say:—

No. 9938—“An Act to amend the ‘*Superannuation Act 1958*’ and Section 8C of the ‘*Pensions Supplementation Act 1966*’.”
(*Superannuation (Fund Contributions) Act 1983*)

No. 9939—“An Act to authorize the Treasurer of Victoria to assign certain copyright and trade marks and for other purposes.”
(*Crown Intellectual Property (Assignment) Act 1983*)

No. 9940—“An Act to provide for the payment of certain fees under the ‘*Associations Incorporation Act 1981*’, to exempt from stamp duty certain instruments giving effect to the vesting of land in incorporated associations, for those purposes to amend the ‘*Associations Incorporation Act 1981*’ and for other purposes.”

(*Associations Incorporation (Amendment) Act 1983*)

Given under my Hand and the Seal of the State of Victoria aforesaid, at Melbourne, this thirteenth day of September, in the year of our Lord One thousand nine hundred and eighty-three and in the thirty-second year of the reign of Her Majesty Queen Elizabeth II.

(L.S.)

BRIAN MURRAY

By His Excellency's Command,

JOHN CAIN

Premier

GOD SAVE THE QUEEN!

No. 9938—This Act shall come into operation on a day to be fixed by proclamation of the Governor in Council published in the *Government Gazette*.

No. 9939—This Act shall come into operation on the day on which it receives the Royal Assent.

No. 9940—This Act shall come into operation on the day on which it receives the Royal Assent.

Co-operation Act 1981

CHANGE OF NAME OF A SOCIETY

Notice is hereby given that St Albans Soccer Club Co-operative Limited which was incorporated as a Community Advancement Society under the abovenamed Act on 11 December 1979 has registered a change of its name and is now incorporated under the name of St Albans Dinamo Soccer Club Co-operative Limited under the said Act.

Dated at Melbourne this 8 September 1983

P. J. ROGAN

Deputy Registrar of Co-operative Societies

NOTICE TO MARINERS

No. 39T of 1983

AUSTRALIA — VICTORIA

BARWON HEADS

LIGHT EXTINGUISHED

The quick flashing red light on the Barwon Heads Entrance Light-buoy, Lat. 38°17'3"S., Long. 144°30'2"E. (Approx.) has been temporarily extinguished.

Further Notice will issue.

Charts temporarily affected: AUS 143, AUS 350, AUS 788.

A. J. WAGGLEN

Port Officer

Ports and Harbors Division

168 Exhibition Street

Melbourne 3000

8 September 1983

Transport Act 1983
ROAD TRAFFIC AUTHORITY
COMMERCIAL PASSENGER AND GOODS VEHICLE
APPLICATIONS

Notice is hereby given that the following applications will be considered by the Road Traffic Authority on 4 October 1983.

Notice of any objections should be forwarded to reach the Officer in Charge, Passenger and Goods Division not later than 28 September 1983.

It will not be necessary for interested parties to appear on the hearing date specified, unless advised in writing by the Authority.

Notification of the date for consideration of applications which are objected to and which require determination by the Road Transport Licensing Tribunal will be published by further notice in this *Gazette*.

Donric Pty. Ltd., Sunbury—Application to license one commercial passenger vehicle with seating capacity for 45 persons to operate as follows:—

- (a) For the carriage of school children between Tullamarine and Salesian College, Sunbury, commencing at the intersection of Melrose Drive and Mickleham Road, Tullamarine via Mickleham Road, Somerton Road, Wildwood Road, Sunbury Road and Macedon Street to the College.

Timetable: Depart Tullamarine 7.45 a.m.; Arrive College 8.10 a.m.; Depart College 4.00 p.m.; Arrive Tullamarine 4.25 p.m.

Fares:— To be determined.

- (b) Under the same terms and conditions as contained in permit number 7211 which authorises a service between Station Street, Sunbury and the Catholic Regional Colleges at Sydenham and North Keilor and various Essendon Schools.
- (c) Under charter conditions from within a 20km pick-up radius of Sunbury.

Note (i) The vehicle to be licensed would hold a 2 star rating for charter purposes.

- (ii) This application replaces a previous application which appeared in *Victoria Government Gazette* No. 81 dated 24 August 1983.

R. K. and F. E. Elias, Wodonga—Application to license a vehicle to be purchased to operate as a Country Hire car from "Kinross", Ebdon.

Note:

- (i) This application replaces a previous application which appeared in the *Victoria Government Gazette* No. 26 dated 23 March 1983.
- (ii) The application was lodged following a Conference of Interested Parties held on 7 September 1983.

R. K. and F. E. Elias, Wodonga—Application to license a vehicle to be purchased, to operate as a Country Taxi with a 5km pick-up radius of the Ebdon Post Office.

Mrs G. Hellman, Wodonga—Application to license a 1979 Ford Sedan with seating capacity for 5 persons to operate as a Country Hire car from 263 High Street, Wodonga.

Note:

- (i) This application replaces a previous application which appeared in the *Victoria Government Gazette* No. 26 dated 23 March 1983.
- (ii) The application was lodged following a Conference of Interested Parties held on 7 September 1983.

Mrs J. D. Irvine, Deer Park—Application to license one commercial passenger vehicle with seating capacity for 6 persons, to operate as a Touring Omnibus on the following tours:—

- (a) Full Day Tour of The Blue Dandenongs. Depart Melbourne Hotels at 9.15 a.m. via the Eastern Suburbs along the South Eastern Freeway and the Burwood Highway

to Monbulk, stopping at the Inferny Nursery for the Kookaburra Show then on to the Fern Grotto for an inspection of the garden setting and the exotic world of ferns. Then a scenic drive to Burnham Beeches Country House Hotel for lunch and an inspection of the estate. Then on to the Alfred Nicholas Memorial Gardens and the Australian Stockade for an inspection. Departing for Hotels in Melbourne at 4.30 p.m. Fare:— \$40.00 per person. (The cost of lunch is included in the fare.)

- (b) Full Day Tour to Ballarat. Depart Melbourne Hotels at 9.15 a.m. via the Western Highway stopping at St Anne's Winery, Myrning then on to Ballarat for an inspection of Lake Wendouree, the Eureka Stockade and Sovereign Hill Gold Mining Town stopping for lunch at the United States Hotel, Sovereign Hill. Departing for Motels in Melbourne at 4.15 p.m. Fare:— \$40.00 per person (the cost of lunch and admittance charges are included in the fare).

Note:

- (i) This application replaces a previous application which appeared in *Victoria Government Gazette* No. 20 dated 2 March 1983.
- (ii) The application was lodged following a Conference of Interested Parties held on 1 September 1983.

Pulfran Constructions Pty. Ltd., Belgrave—Application to license one commercial passenger vehicle with seating capacity for 39 persons, to operate a service for the carriage of school children between Olinda and Knoxfield College, Wantirna South, as follows:—

Route:— Commencing from the Bus Terminal at the Mt Dandenong Hotel, Olinda via Mt Dandenong Tourist Road, Sherbrooke Road, Monbulk Road, Belgrave-Hallam Road, Benson Street, Station Street, McNicol Road, Clifford Grove, Glenfern Road, Morris Road, Old Belgrave Road, Edward Street, Johns Street, Dawson Street and Burwood Highway to Knoxfield College. Return via reverse of the above route.

There will be no pick-up at the township of Kallista and the service will operate express between Dawson Street, Upper Fern-tree Gully and the College.

Timetable: Depart Olinda 8.00 a.m.; Depart Knoxfield College 3.30 p.m.

Fares:— To the College from:—

Olinda \$200.00 per term; Sherbrooke Junction \$190.00 per term; Kallista \$180.00 per term; Belgrave \$170.00 per term; Upper Fire Station \$160.00 per term; Dawson Street UFG \$150.00 per term.

Note:

- (i) This application replaces a previous application which appeared in *Victoria Government Gazette* No. 26 dated 23 March 1983.
- (ii) The application was lodged following a Conference of Interested Parties held on 1 September 1983.

Application for renewal of licences as shown by the persons listed hereunder to operate under the same terms and conditions.

A. Asproptomitis, Greensborough, ST 6521.

Olympic Tyre & Rubber Co. Pty. Ltd., Campbellfield, SV 254.
14 September 1983

C. J. V. SMITH, Chief General Manager
Registration and Regulation

ERRATUM

In *Government Gazette* No. 90 of 9 September 1983 the heading "Minister of the Crown — Resignations" should read "Ministers of the Crown".

Country Fire Authority Act

PERMISSION TO HOLD FIRE BRIGADE DEMONSTRATION

In pursuance of the provisions of Section 103 of the *Country Fire Authority Act 1958*, the Country Fire Authority has granted approval for the holding of a fire brigade demonstration as under:—

Rural Fire Brigades

At Newbridge on Sunday 13 November 1983.
12 September 1983

L. A. CRUICKSHANK, Acting Secretary

Veterinary Surgeons Act 1958 (As Amended)

Notice is given that at a hearing conducted by the Veterinary Board of Victoria held on Wednesday 6 July 1983, Dr Emily F. Maudsley, a Registered Veterinary Surgeon, of 60 Scoresby Street, Kerang, Victoria, was found guilty of breaching the provisions of Regulation 33 of the *Veterinary Surgeons Regulations 1969* in that she had in connection with the practice of her profession or business advertised in a manner prohibited by the Regulations and was ordered to pay a fine of \$100.00.

L. M. TROUNCE, Registrar,
Veterinary Board of Victoria

CONTRACTS ACCEPTED — (Series 83-85)

Schedule No. 1/72

CARBON PAPERS AND TYPEWRITER RIBBONS

Contract from 1 September 1983 to 31 August 1985

- 1983/538 Adler Business Machines, 35 Albert Road, Melbourne. Telephone 267 5311.
- 1983/540 Carnassey Carbons & Ribbons Mfg. Pty. Ltd., 593 Gardeners Road, Mascot, N.S.W. Telephone (02) 667 2431.
- 1983/541 Columbia Products Ltd., 706 Mowbray Road, Lane Cove, N.S.W. Telephone (02) 427 0311.
- 1983/544 IBM Australia Ltd., 211 Sturt St., South Melbourne. Telephone 699 3699.
- 1983/547 Scribal Pty. Ltd., 37 Thistlethwaite Street, South Melbourne. Telephone 699 2777

All supplies under this Schedule will be ordered by the Stores Officer, Education Department and must be delivered as directed by him.

Item No.	Description of Articles	Unit of Measure	Rate	Name of Contractor
			\$	
	CARBON PAPERS			
	For Typewriters, blue and black, in packets of 100 sheets			
1.	5 copies, standard weight, all size	per pkt	2.00	Columbia Products Ltd.
2.	12 copies, light weight. All size	per pkt	2.25	
3.	Pencil—in packets of 100 sheets. All size, blue or black	per pkt	2.63	
4.	Pens—in packets of 100 sheets, all size blue or black	per pkt	2.49	Carnassey Carbons & Ribbons Manufacturing Pty. Ltd.
4.(a)	Film Carbon—in packets of 100 sheets, A4, plastic backed, black standard weight (up to 5 copies)	per pkt	6.50	
	TYPEWRITER RIBBONS			
	Standard Nylon Fabric Ribbon			
5.	Black, 13mm wide and approx. 10m long—to fit both manual and electric	per each	..	Apply Tender Board
6.	Red and black, 13mm wide and approx. 10m long—to fit both manual and electric	per each	..	Apply Tender Board
7.	Black—14.3mm wide and approx. 10m long to suit IBM electric	per each	..	Purchase Regulation 84
	FILM CARBON RIBBONS			
8.	Black, 8mm wide and approx. 210mm long, 89mm dia. to suit electric machines except IBM type	per each	0.48	Columbia Products Ltd.
9.	Black, 14.3mm wide and approx. 10m long, twin spool, to suit IBM Selectric 71	per each	0.60	Columbia Products Ltd.
10.	Black correctable cartridge, to suit Golf Ball machine	per each	..	Apply Tender Board
12.	Black, correctable, cartridge to suit Adler Daisy wheel machine	per each	3.90	Adler Business Machines
13.	Black, correctable, cartridge to suit IBM Selectric III	per each	4.29	IBM Australia Ltd.
	LIFT OFF TAPES:			
14.	Clear—for use on Golf Ball machines	per each	0.36	Columbia Products Ltd.
15.	Clear—for use on Adler Daisy Wheel machines	per each	..	Apply Tender Board
16.	White—for use on IBM Golf Ball machines	per each	0.45	Scribal Pty. Ltd.

Departments to note: Trading terms are nett 30 days unless otherwise stated.

Approved: R. A. JOLLY, Treasurer 6.9.83

STATE TENDER BOARD — CONTRACTS ACCEPTED AMENDMENTS				Schedule Number	Item Number	New Rate	Effective Date
Schedule Number	Item Number	New Rate	Effective Date				
		\$				\$	
					16	0.4356†	
						0.4581‡	23.8.83¶
						0.4593‡	24.8.83
					17	0.4206	
					18	0.4356†	
						0.4581‡	23.8.83¶
						0.4593‡	24.8.83
						0.4604#	
					19	0.4244 (D)	
						0.4394 (S/Stn)	
					20	0.4244 (D)	
						0.4394† (S/Stn)	
						0.4594# (S/Stn)	
					21	0.5655	
					22	0.4335*	
					23	0.5273	
					24	0.3973*	
					25	0.5458*	
						0.4742*	29.8.83
					28	0.3728*	24.8.83
					29	0.3721*	
					30	0.3921*	
					31	0.3921*	
					32	0.3948*	
					33	269.39*	
					34	0.3821	
					41	1.0577 (M)*	5.9.83
						1.2077 (C)*	
					42	1.0707 (M)*	
						1.2207 (C)*	
					43	1.2217 (M)*	
						1.3717 (C)*	
					44	0.9948 (M)*	
						1.1448 (C)*	
					45	0.9268 (M)*	
						1.0768 (C)*	
						* Trading Terms Unchanged	
						† The Shell Company of Australia Limited	
						‡ Caltex Oil (Australia) Pty. Limited	
						¶ New rates only to apply to purchases made after 8.00 p.m.	
						# BP Australia Limited	
<i>Industrial Gases (In Cylinders) (Series 1983/85)</i>							
110	Departments to note: All orders for contract items supplied by Liquid Air Australia Limited under this Schedule are to be forwarded to: Liquid Air Australia Limited, 2-6 Rutland Street, Braybrook, Vic. 3019						
<i>Cordage, Ropes, Twine, etc. (Series 1982/84)</i>							
1/28	13	2.094	20.7.83				
	14	1.598					
	15	0.980					
	16	0.826					
	17	0.647					
	18	0.554					
	19	0.418					
	20	0.418					
	21	0.305					
	22	0.227					
	24	0.172					
	26	0.092					
	28	0.058					
	32	1.077					
	33	0.949					
	34	0.704					
	35	0.567					
	36	0.491					
	37	0.396					
	38	0.340					
	39	0.257					
	40	0.198					
	41	0.171					
	42	0.122					
	43	0.108					
	45	0.064					
	47	0.037					
	54	48.90					
	55	44.34					
<i>Motor Spirit (Bulk) — State Petrol Centre (Series 1983)</i>							
1/53A	1	0.3925	24.8.83				
	2	0.4056					
<i>Motor Spirit, Fuel Oils, Lubricants, etc. (Series 1982/83)</i>							
1/53B	3	0.4005	24.8.83				
	4	0.4060					
	5	0.4260*					
	6	0.4260*					
	7	0.4136					
	8	0.4191					
	9	0.4391*					
	10	0.4391*					
	11	0.4075					
	12	0.4225†					
		0.4431‡	23.8.83¶				
		0.4443‡	24.8.83				
	13	0.4075					
	14	0.4225†					
		0.4431‡	23.8.83¶				
		0.4443‡	24.8.83				
		0.4474#					
	15	0.4206					
<i>Hand Tools — General (Series 1983/84)</i>							
1/56	5	12.45(a)	1.9.83				
	6	14.68(a)					
	7	‡					
	8	17.36(b)					
	9	19.86(b)					
	10	21.95(b)					
	16	0.95*	11.8.83				
	19	10.00(c) (18mm)	1.9.83				
		10.00(c) (24mm)					
		10.00(c) (32mm)					
		12.00(c) (18mm)					
		12.00(c) (24mm)					
		12.00(c) (32mm)					
	20	31.60(d) (18mm)					
		31.60(d) (24mm)					
		31.60(d) (32mm)					
		31.60(d) (18mm)					
		31.60(d) (24mm)					
		31.60(d) (32mm)					
	21	15.12(e) (12inch)					
		17.58(e) (14inch)					

Schedule Number	Item Number	New Rate	Effective Date
		\$	
	26	1.05(f) (10mm) 1.20(f) (13mm) 1.35(f) (15mm) 1.68(f) (19mm) 1.98(f) (21mm) 2.31(f) (25mm)	
	27	3.71(g) (6mm) 3.71(g) (10mm) 3.92(g) (13mm) 4.14(g) (15mm) 4.14(g) (19mm) 4.36(g) (25mm) 5.88(g) (31mm) 7.84(g) (38mm) 9.07(g) (44mm) 11.26(g) (50mm)	
	28	3.10(h) (6mm) ‡ (10mm) 3.16(h) (13mm) 3.26(h) (15mm) 3.41(h) (19mm) 3.57(h) (25mm) 3.88(h) (31mm) ‡ (38mm) ‡ (44mm) ‡ (50mm)	
	29	4.11(i) (6mm) 4.16(i) (10mm) 4.47(i) (13mm) 4.72(i) (15mm) 4.88(i) (19mm) 5.13(i) (25mm) 6.88(i) (31mm) 7.52(i) (38mm) 12.29(i) (44mm) 13.85(i) (50mm)	
	47	Stubbs (j) Price List less 35%	
	205	16.19(k)	
	237	‡	
	238	‡	
	239	‡	
	316	6.22(l)	

- (a) Delete: Apply Tender Board
Add: "Cyclone" — Eliza Tinsley (Aust.) Pty. Ltd.
- ‡ Delete: Apply Tender Board
Add: Purchase Regulation 84
- (b) Delete: Apply Tender Board
Add: "Kelly" — Eliza Tinsley (Aust.) Pty. Ltd.
- * Trading Terms Unchanged
- (c) Delete: Apply Tender Board
Add: "Stead" — Eagle & Globe Steel Ltd.
- (d) Delete: Apply Tender Board
Add: "per hundred" — "Stanley" — Industrial Hardware ¶
- (e) Delete: Apply Tender Board
Add: "per 10" — "P & N" — Dane Taylor & Co. ¶
- (f) Delete: Apply Tender Board
Add: "Evro" — Dane Taylor & Co. ¶
- (g) Delete: Apply Tender Board
Add: "Footprint" — Howard F. Hudson Pty. Ltd. ¶
- (h) Delete: Apply Tender Board
Add: "Toledo" — F. Lowe & Co. Pty. Ltd. ¶
- (i) Delete: Apply Tender Board

Schedule Number	Item Number	New Rate	Effective Date
		\$	
		Add: "Marples" — Industrial Hardware Pty. Ltd. ¶	
(j)	Delete: Apply Tender Board Add: "Stubbs" — A. J. Calder Industrial Supplies ¶		
(k)	Delete: Apply Tender Board Add: Industrial Hardware Pty. Ltd. ¶		
(l)	Delete: Apply Tender Board Add: "Kemtex Red" — O. T. Lempriere & Co. Limited		
¶ Subject to same trading terms as existing contract items supplied by these firms.			
<i>Provisions—Melbourne and Metropolitan District (Series 1983/84)</i>			
2/01	56	2.54 Ω	1.8.83
Ω Change of Description: Delete: "per litre" Add: "per jar"			
<i>Provisions — Butter (Series 1983/84)</i>			
2/03	2	44.19	1.8.83
	3	44.19	
	7	44.19	
	8	44.19	

J. M. PAWSON
Secretary to the Tender Board

Labour and Industry Act 1958

ORDER OF EXEMPTION ISSUED UNDER THE PROVISIONS OF SECTION 80F

Pursuant to the provisions of section 80F of the *Labour and Industry Act 1958*, I, Steven Marshall Crabb, Minister of Labour and Industry, having considered an application from the City of South Melbourne, hereby make this Order exempting shopkeepers of shops in the "Emerald Hill Estate" bounded by Clarendon, Park, Cecil and Market Streets in the City of South Melbourne from being required to close and keep closed their shops in accordance with Part VI of the said Act during a "Community Festival" to be conducted by the South Melbourne Chamber of Commerce from 10.00 a.m. to 5.00 p.m. on Sunday 25 September 1983.

8 September 1983

S. M. CRABB
Minister of Labour and Industry

Labour and Industry Act 1958

ORDER OF EXEMPTION ISSUED UNDER THE PROVISIONS OF SECTION 80F

Pursuant to the provisions of section 80F of the *Labour and Industry Act 1958*, I, Steven Marshall Crabb, Minister of Labour and Industry, having considered an application from the Council of the City of Moorabbin, hereby make this Order exempting shopkeepers of shops in Centre Road, East Bentleigh between the intersection with Tucker Road and No. 801 and those shops in East Boundary Road within 100 metres of Centre Road which form part of the East Bentleigh Shopping Centre, from being required to close and keep closed their shops during a Community Festival from 12.00 noon until 6.00 p.m. on Saturday 29 October 1983.

This Order does not operate to permit the sale or disposal of liquor within the meaning of the *Liquor Control Act 1968* by any shopkeeper at any time when he would, but for this Order, be required to close and keep closed his shop in accordance with Part VI.

8 September 1983

S. M. CRABB
Minister of Labour and Industry

State Electricity Commission Act No. 6377

State Electricity Commission (Amendment) Act 1979, No. 9296

Pursuant to the Sixth Schedule of the *State Electricity Commission Act 1958* as amended, the State Electricity Commission hereby gives notice of the supplementary terms and conditions on which the State Electricity Commission of Victoria supplies electricity to customers who elect to take Standby and Parallel Supplies (Cogeneration) Tariff S or All Purposes Contract Demand (High Voltage) Tariff H. These conditions are in addition to the standard tariff conditions listed in the *Victorian Government Gazette* No. 80 — 17 August 1983 which may be amended from time to time.

STANDBY AND PARALLEL SUPPLIES: HIGH VOLTAGE SUPPLEMENTARY TARIFF CONDITIONS

1. *General*

1.1 These conditions apply to installations in which all or part of the total electricity requirements are generated from private generation which, subject to the approval by the Supply Authority, is operated in parallel with the Supply Authority System.

1.2 Standby is available only to high voltage customers who take standard contract or maximum demand tariffs (Tariffs H or M respectively) for the normal portion of their supply.

1.3 These conditions, which are supplementary to the Standard Tariff Conditions for Victoria, may be varied by the Supply Authority from time to time.

2. *Definitions*

2.1 Standby supply is one which is required from the Supply Authority for the operation of electrical equipment normally supplied from power plant owned by the customer.

2.2 Maximum Contract Demand (MCD) is the demand in kilowatts negotiated or taken by the customer under the current contract and is the sum of two components, viz—

- The Normal Contract Demand (NCD) which is the demand in kilowatts up to which the standard tariff (Tariff H or Tariff M as appropriate) may apply for both demand and energy quantities.
- The Standby Contract Demand (SCD) is the demand in kilowatts nominated by the customer to be his standby requirement and as agreed by the Supply Authority. Tariff S shall apply to both SCD and to energy quantities which are in excess of NCD. The customer may elect to have the SCD between zero and the MCD provided that the SCD does not exceed the nameplate rating of the customer's installed private generation plant.

3. *Contract Period*

Customers taking supply at voltages from 6.6 kV to 66 kV inclusive, shall enter into a contract to take supply on the tariff for a minimum period of five years. Special contractual conditions apply for 220 kV supplies.

4. *Changes to Contract Demands*

The Contract Demands are established by negotiation between the customer and the Supply Authority. They may be changed by subsequent re-negotiation, or by the metered maximum demand in a month exceeding the Maximum Contract Demand. In either event, unless a higher MCD is subsequently established, or unless special exemptions apply as detailed in Item 4.2 (b) below, a MCD shall apply for a period of not less than 12 months.

A customer first taking supply under these conditions will be allowed three months operational experience before selecting firm Contract Demand quantities to apply for the following 12 months. Within this three-month period, the customer may modify his Contract Demand quantities after each month's operation, but such modification shall take effect on supply received following the next meter reading after request for such modification.

Any increase in MCD will be subject to the necessary capacity being available in the Supply Authority System.

4.1 *Negotiated Changes*

Where a customer requires an increase in the MCD, written advice should be lodged with the Supply Authority at the earliest opportunity to enable, if required, augmentation of the supply system.

Where a customer requires a reduction in the MCD or a change to NCD or SCD, 12 months written notice shall be given to the Supply Authority. Such changes shall apply to supply provided after the meter reading date first following the expiration of the 12 months' notice.

Any reduction in MCD shall be conditional upon such reduced MCD being not exceeded for 12 months following its application. Any MCD recorded within the 12 months' period which exceeds such reduced MCD shall become the MCD retrospectively for the full period.

4.2 *Changes Following MCD being Exceeded*

In the event that a new MCD is established by the recording of a higher demand, the following shall apply:

- (a) A corresponding increase shall apply to the Normal Contract Demand.
- (b) The new MCD shall apply for at least 12 months unless exempted under either of the following circumstances:
 - If it is a fault on the customer's electrical installation which caused a new MCD to be established, the MCD may be reduced back to the previous level after three months provided that the customer can demonstrate to the Supply Authority's satisfaction the cause of the fault and that the fault has been corrected; or
 - Where the capacity of the existing electricity supply system is inadequate to make supply available at a higher rate on a continuous basis. In this case the customer shall be advised that the new MCD would only apply for the month in which it was established, pending augmentation of the supply system and re-negotiation of revised contract demands. The MCD thereafter would be limited to the available capacity, as determined by the Supply Authority, of the existing supply system by suitable load limiting equipment installed by the customer to the satisfaction of the Supply Authority.

5. *Buy Back Provision*

The Supply Authority may purchase energy from private generation at the rates as determined under Tariff S (Buy Back Component). Suitable protection and control equipment shall be installed by the customer to the satisfaction of the Supply Authority to limit the buy back demand to the Buy Back Contract Demand as specified in the Supply Agreement.

6. *Conditions for Parallel Supply*

6.1 A customer may operate generators in parallel with the supply grid with or without standby subject to the following conditions:

- The requirements of SEC Wiring Regulations 1981 are satisfied.
- The technical conditions of parallel operation as required by the Supply Authority are satisfied.

6.2 *Programmed Outages of Units Greater than 50 MW*

A customer taking supply under Tariff S who has individual alternators of 50 MW or greater nameplate rating, will be required to maintain close co-operation with the Commission in matters relating to scheduling of plant maintenance. Details of these requirements will be included in the Supply Contract.

7. *Other Conditions*

7.1 *Normal Contract Demand Component — Tariffs H or M*

Rates for this component are those effective for the standard demand tariff for high voltage supply.

- A customer supplied under Tariff M may select Tariff H or elect to remain on Tariff M.
- A new customer, or customer previously supplied on other than Tariff M, shall be supplied under Tariff H for this component.

7.2 The minimum charge shall be the sum of four charges—

- Minimum demand charge under Tariffs H or M as appropriate (for Tariff H, 1000 kW or NCD whichever is the greater; for Tariff M, 500 kW or 60 per cent of NCD whichever is the greater).
- The product of the Standby Contract Demand and the demand charge under Tariff S.
- The energy charge under Tariffs H or M as appropriate for all energy consumption up to the NCD (or corrected NCD if appropriate).
- The energy charge under Tariff S for all energy in excess of the NCD.

7.3 The prescribed off-peak hours under Tariff S, and Tariff H if applicable, shall be Standard Time except during periods of daylight saving when such times shall be Summer Time.

TARIFF H SUPPLIES

SUPPLEMENTARY TARIFF CONDITIONS

These Conditions which are supplementary to the Standard Tariff Conditions for Victoria may be varied by the Supply Authority from time to time.

1 *Changes to Contract Demand*

The Contract Demand which is established by negotiation between the customer and the Supply Authority may be changed by subsequent renegotiation, or by the metered maximum demand in a month exceeding the Contract Demand. In either event, unless a higher Contract Demand is subsequently established, or unless special exemptions apply as detailed in Item 1.2 below, a Contract Demand shall apply for a period of not less than 12 months.

1.1 *Negotiated Changes*

Where a customer requires an increase in the Contract Demand, written advice should be lodged with the Supply Authority at the earliest opportunity to enable, if required, augmentation of the supply system. An increase in Contract Demand will be subject to capacity being available in the Supply Authority System.

Where a customer requires a reduction in the Contract Demand, 12 months' written notice shall be given to the Supply Authority. Such reduction shall apply to supply provided after the meter reading date first following the expiration of the 12 months' notice.

Any reduction in Contract Demand shall be conditional upon such reduced Contract Demand being not exceeded for 12 months following its application. Any demand recorded within the 12 months' period which exceeds such reduced Contract Demand shall become the Contract Demand retrospectively for the full period.

1.2 *Changes Following Contract Demand Being Exceeded*

In the event that a new Contract Demand is established by recording of a higher demand, the following shall apply:

The new Contract Demand shall apply for at least 12 months unless exempted under either of the following circumstances:

- If it is a fault on the customer's electrical installation which caused a new MCD to be established, the MCD may be reduced back to the previous level after three months provided that the customer can demonstrate to the Supply Authority's satisfaction the cause of the fault and that the fault has been corrected; or
- Where the capacity of the existing electricity supply system is inadequate to make supply available at a higher rate on a continuous basis. In this case the customer shall be advised that the new MCD would only apply for the month in which

it was established, pending augmentation of the supply system and re-negotiation of revised contract demands. The MCD thereafter would be limited to the available capacity, as determined by the Supply Authority, of the existing supply system by suitable load limiting equipment installed by the customer to the satisfaction of the Supply Authority.

2 *Metering Changes*

An existing customer electing to transfer to Tariff H must agree to pay the costs of any necessary metering change.

3 *Multiple Supplies*

Normally, a single high voltage supply should be adequate to satisfy a customer's total needs for electricity on a property. Where, in accordance with Tariff Rulings, multiple supplies are provided to a property, each supply would normally be separately metered and billed under a separate Contract Demand for each supply.

However, where the following conditions apply, combined metering may be offered to enable the application of a coincident Contract Demand to such multiple supplies:

- Where multiple supplies are taken from and metered at a single Supply Authority substation, switch, metering or other single enclosure containing Supply Authority supply terminations. A single enclosure is defined as one which is not separated into two or more parts by customer land or equipment and includes adjacent unenclosed structures displaced by no greater distance than if they were to be in a single enclosure.
- Where multiple supplies are provided to an installation which may be operated as a single interconnected electrical installation.
- The customer must agree to pay all Supply Authority costs in excess of those for a single supply, in particular—

- additional metering costs;
- capital costs of any feeder capacity reserved in excess of the Contract Demand;
- if required by the Supply Authority, the operating and maintenance costs associated with such reserve feeder capacity.

4 *Standard Time*

The times nominated for off-peak rates, notwithstanding the operation of Summer Time, are Standard Time.

However, except in the case of Standby and Parallel Supply customers where special conditions apply, Summer Time may be applied where—

- suitable metering is available to enable Summer Time to be applied without cost to the Supply Authority; or
- where the customer agrees to reimburse the Supply Authority for any changes to the metering to adjust for the Summer Time/Standard Time changeovers.

A. J. FORRESTER, Secretary
State Electricity Commission of Victoria

DEPARTMENT OF MINERALS AND ENERGY APPLICATIONS FOR MINING LEASES DECLARED ABANDONED

No. 989; Rupert Charles Bilston; 1 ha, Parish of Amherst.
No. 1026; Albert Britten and Dale Thomas Watts; 21 ha, Parish of Tchuterr.

MINING LEASES EXPIRED

No. 510; Graeme John Bond and Dianne Marie Bond; 21 ha, Parish of Banu Bonyit.
No. 550; Samuel Phillip Farley; 2 ha, Parish of Budgerum East.

EXPLORATION LICENCES GRANTED

- No. 1276: Eastern Resources No Liability; 66 km², comprising Graticular Block No. 829 Melbourne Map Sheet.
- No. 1355: John Morton Brady; 66 km², comprising Graticular Block No. 747 Melbourne Map Sheet.
- No. 1360: Hardrock Exploration Pty. Ltd.; 132 km², comprising Graticular Blocks Nos. 1109 and 1181 Melbourne Map Sheet.
- No. 1362: CRA Exploration Pty. Limited; 264 km², comprising Graticular Blocks Nos. 556, 628, 698 and 699 Hamilton Map Sheet.

TERMS OF EXPLORATION LICENCES EXTENDED

- No. 1205: Castlemaine Engineering & Mining Co. Pty. Limited; 198 km², comprising Graticular Blocks Nos. 937, 938 and 939 Melbourne Map Sheet.
- No. 1238: Western Mining Corporation Limited and BP Mining Australia Pty. Ltd.; 462 km², comprising Graticular Blocks Nos. 404, 405, 547, 548, 619, 620 and 621 Melbourne Map Sheet.
- No. 1239: Western Mining Corporation Limited and BP Mining Australia Pty. Ltd.; 330 km², comprising Graticular Blocks Nos. 406, 477, 478, 549, and 550 Melbourne Map Sheet.
- No. 1242: Western Mining Corporation Limited; 396 km², comprising Graticular Blocks Nos. 507, 579, 580, 651, 652 and 724 Melbourne Map Sheet.
- No. 1243: Western Mining Corporation Limited; 396 km², comprising Graticular Blocks Nos. 506, 577, 578, 649, 650 and 723 Melbourne Map Sheet.
- No. 1244: Western Mining Corporation Limited; 132 km², comprising Graticular Blocks Nos. 921 and 922 Hamilton Map Sheet.
- No. 1245: Western Mining Corporation Limited; 462 km², comprising Graticular Blocks Nos. 849, 850, 851, 923, 993, 994, and 995 Hamilton Map Sheet.
- No. 1248: Golden Eagle Mining Pty. Limited; 120 km², comprising Graticular Block Nos. 45 Melbourne Map Sheet and Graticular Blocks Nos. 3429 and 3430 Canberra Map Sheet.
- No. 1268: International Oil Proprietary; 64 km².

SEARCH LICENCE EXPIRED

- Nos. 2435 and 2436: Clarence William Davis and John Balmain Griffiths; 33 ha and 26 ha respectively, Parishes of Moondarra and Numbruk.

TAILINGS LICENCE GRANTED

- No. 4892: Forests Commission Victoria; to remove tailings from the "Tonsil Mine" situated in the Parish of Derril.

TAILINGS LICENCES EXPIRED

- No. 4595: Jeffrey MacCallum; to remove tailings from the "Nuggetty Mine Dump" situated at Maldon.
- No. 4664: Keith Lakey; to remove tailings from the "Nuggetty Mine Dump" situated at Maldon.
- No. 4728: James Leonard Nevill; to remove tailings from the "North Ajax Dump" situated north west of Daylesford.
- No. 4749: Shire of Bet Bet; to remove tailings from an area along Burnt Creek at Bromley and approx. 2 km south east of Dunolly.
- No. 4755: Gregory Newton, Raymond Newton and Christopher Newton; to remove tailings from "Welshman's Reef Dump" situated at Stawell.

- No. 4756: John Valentine Wallace; to remove tailings from the "Central Ajax Mine" situated at Daylesford.
- No. 4759: Brian Burton; to remove tailings from the site of McFarlane's Treatment Works situated in the Parish of Sandhurst.
- No. 4764: Kevin Thomas Wilson; to remove tailings from a sand tailings dump located in Long Gully just south of the South Wattle Gully mine at Chewton South.
- No. 4902: Bendigo Gold Associates; to remove tailings from the "Catherine Reef United Dump" situated in the Parish of Sandhurst.

ADDENDUM

Extractive Industry Licence No. 791-1 appearing under the heading of "Extractive Industry Licence Granted" in the *Government Gazette* of 31 August 1983 is hereby amended to read Extractive Industry Licence No. 791-2.

D. R. WHITE

Minister for Minerals and Energy

COMMONWEALTH OF AUSTRALIA

Petroleum (Submerged Lands) Act 1967

NOTICE OF GRANT OF A PIPELINE LICENCE

Hematite Petroleum Pty. Ltd. and Esso Exploration and Production Australia Inc., of 140 William Street, Melbourne and care of Price Waterhouse Nominees (Victoria) Pty. Ltd., 447 Collins Street, Melbourne respectively have been granted Pipeline Licence No. VIC/PL19 in respect of the construction of a 250 mm pipeline along the route and in the position described hereunder for the conveyance of liquid hydrocarbons between the Snapper platform and the Marlin platform, situated as described below in Licence Areas VIC/L10 and VIC/L3 respectively, of which they are registered holders.

Route and Position of the Pipeline

Between the Snapper platform at or about Latitude 38 deg. 11 min. 44 sec. South, Longitude 148 deg. 01 min. 28 sec. East and the Marlin platform situated at or about Latitude 38 deg. 13 min. 55 sec. South, Longitude 148 deg. 13 min. 09 sec. East along the sea bed.

Dated this 7 September 1983

Made under the *Petroleum (Submerged Lands) Act 1967* of the Commonwealth of Australia.

DAVID WHITE

Designated Authority

Town and Country Planning Act 1961

SHIRE OF MALDON PLANNING SCHEME 1980

Notice of Approval

In pursuance of the powers conferred by the *Town and Country Planning Act 1961*, the Governor in Council on 13 September 1983 approved the abovementioned scheme in respect of the municipal district of the Shire of Maldon and for which the Council of the Shire of Maldon is the Responsible Authority.

The scheme comes into operation on the date this Notice is published in the *Government Gazette*.

The Scheme replaces the existing Interim Development Order and that part of the Lake Cairn Curran Planning Scheme that covers the Shire of Maldon. It includes 5 zones and a number of special control areas.

A copy of the Planning Scheme as approved may be inspected free of charge, during office hours, at the office of the Ministry for Planning and Environment (Planning Information Section), 5th Floor, 235 Queen Street, Melbourne and at the office of the Shire of Maldon, High Street, Maldon.

J. B. LAWSON, Acting Secretary for Planning and Environment.

Auction Sales Act 1958

Hamilton—Notice is hereby given that the Annual Meeting of Justices, for the Licensing of Auctioneers, will take place at the Hamilton Magistrates' Court on Tuesday 22 November 1983 at 10 a.m.

K. E. CROTTY, Clerk of Courts

**PRIVATE
ADVERTISEMENTS**

CITY OF FOOTSCRAY

Loan No. 169

*Notice of Intention to Borrow the Sum of \$1,500,000 for
Permanent Works and Undertakings*

Notice is hereby given that the Council of the City of Footscray proposes to borrow the sum of One Million and Five Hundred Thousand Dollars (\$1,500,000) secured by a charge over the general rates of the Municipality, such sum to be raised by the grant of a mortgage in accordance with the provisions of the *Local Government Act 1958*.

1. The maximum rate of interest that may be paid is 15.2 per centum per annum.
2. The period of the loan shall be five years.
3. The loan is to be liquidated by providing out of the Municipal Fund nine equal consecutive half-yearly instalments of \$148,259.10, and a tenth final instalment of \$1,161,291.07 at the end of five years including principal and interest, payable on 1 April and 1 October in each year during the currency of the loan. The first instalment shall be payable on 1 April 1984.
4. Such moneys shall be repayable at the office of the Commonwealth Savings Bank of Australia, Footscray.
5. The purposes for which the loan is to be applied are:—

Municipal Offices — Stage 2 Extensions (part cost)	500,000
Footscray Recreation Centre/Footscray West Senior Citizens Centre Building Development (part cost)	350,000
Purchase of Ring Road Properties	150,000
Electricity Supply Department — purchase of Capital Equipment	500,000

The plans and specifications, the estimate of the cost of the proposed works and a statement showing the proposed expenditure of the moneys to be borrowed are open for inspection at the Town Hall, Footscray.

Dated at Footscray 13 September 1983

8802 B. J. WARD, Town Clerk

**CITY OF KNOX
RENAMING OF ROAD**

Notice is hereby given that pursuant to the provisions of Section 535 (4) of the *Local Government Act 1958*, that the Council of the City of Knox did, by resolution on 6 September 1983, change the name of Bettina Place, Scoresby to Keith Campbell Court, Scoresby.

The abovementioned change of name is to take effect from 1 November 1983.

8818 T. J. NEVILLE, Town Clerk

CITY OF RICHMOND

By-Law No. 191

Council Legislation Review By-Law

A By-Law of the City of Richmond made under Section 228 of the *Local Government Act 1958* and numbered 191 for the purpose of repealing certain By-Laws made by the City of Richmond.

In pursuance of the powers conferred by the *Local Government Act 1958* (as amended) and any and every other power thereunto enabling the Mayor, Councillors and Citizens of the City of Richmond order as follows:

1. This By-Law shall be known as the Council Legislation Review By-Law.
2. The By-Laws made by the City of Richmond as listed in the Schedule to this By-Law are hereby repealed.

SCHEDULE

Number	Short Title or Description	Date of Council Confirmation	Date of Gazetteal
14/16	Imposing Rates for Years 1859/60-1861/62	Unknown	Unknown
18	Rates for Year 1862/63	Unknown	Unknown
19	Establishment of Slaughter Houses	20/11/1862	Unknown
21	Rates for Year 1863/64	Unknown	Unknown
23	Lighting of Vehicles	19/10/1871	7/11/1871
24	Stands for Wood Carts	11/1871	Unknown
25	Appointment of Auditor 1875	Unknown	Unknown
26	Appointment of Auditor 1876	Unknown	Unknown
29	Town Market	7/6/1877	15/6/1877
30	Vehicle Crossing Street Intersections	Unknown	Unknown
32	Traffic and Processions	26/11/1885	4/12/1885
33	Draper's Shops Hours	Unknown	Unknown
34	Penalties for Offences against Shop Closing By-Laws	Unknown	Unknown
35	Furniture Shop Hours	July 1876	Unknown
36	Draper's Shops Hours	Sept. 1886	Unknown
37	Ironmongers Shops	April, 1887	Unknown
38	Crockery Shops Hours	June, 1887	Unknown
40	Carrying of Offensive Materials	6/4/1892	14/4/1892
41	Meat Carts	3/11/1892	23/12/1892
42	Repealing Clause 22 of By-Law 12	Unknown	Unknown
43	Secondhand Clothes Dealers Shop Hours	Aug., 1893	Unknown
44	Butchers' Shop Hours	Feb., 1894	Unknown
45	Abattoirs Management and Fees	20/2/1896	28/2/1896
46	No record	Unknown	Unknown
47	Grocers' Shop Hours	Jan., 1896	Unknown
48	Ironmongers' Shop Hours	July, 1896	Unknown
49	Baths By-Law	24/6/1897	26/2/1902
50	Amending By-Law No. 12	Unknown	Unknown
52	Repealing By-Law No. 39	Unknown	2/7/1902
53	Spitting and Expectoring on Footpaths	13/7/1903	21/10/1903
54	Meeting Procedure & Powers of Council	24/3/1904	4/5/1904
55	Use of "Machines" Traffic	2/6/1904	15/6/1904
56	Writing on Footpaths	14/7/1904	10/8/1904
57	Coal and Firewood	June, 1905	Unknown
58	Bedding and Rags	11/1/1906	21/2/1906
59	Amending By-Law No. 57	June, 1906	Unknown
60	Coal and Firewood	Oct., 1907	Unknown
61	Fowlyards	12/12/1907	22/1/1908
62	Market Dues	14/5/1908	3/6/1908
63	Town Market	20/12/1909	2/2/1910
64	Grazing Cattle	1/3/1909	10/3/1909
65	Bathing Attire — River Yarra	20/12/1909	2/2/1910

Number	Short Title or Description	Date of Council Confirmation	Date of Gazettal
66	Fruit/Vegetable Rubbish	17/1/1910	10/8/1910
67	Sweeping Shops, Delivering Handbills, etc.	6/11/1911	20/12/1911
69	Quarry Explosives	4/12/1911	20/12/1911
69	Night Soil Hours	23/4/1912	15/5/1912
71	Hat Pins	4/11/1912	27/11/1912
72	Bathing Costumes, City Baths	2/12/1912	18/12/1912
74	Regulating Horse Drawn Vehicles	20/7/1914	5/8/1914
75	Hand Trucks, etc.	3/7/1916	18/11/1916
76	Advertisements & Hordings	4/12/1916	17/1/1917
77	Amending By-Law 75	Unknown	2/8/1916
79	Vehicle Ramps	24/4/1917	9/5/1917
80	Rubbish	5/11/1917	21/11/1917
82	Wagon Loads	8/11/1920	1/12/1920
85	Removal Soil	11/4/1921	20/4/1921
86	Motor Garages	19/6/1922	25/10/1922
87	Building Allotments	10/9/1923	10/10/1923
90	No record	Unknown	Unknown
91	Abattoirs	19/5/1924	11/6/1924
92	Childrens Playgrounds Ross & Flevill Streets	16/6/1924	9/7/1924
93	Control Tennis Courts	19/5/1924	23/7/1924
95	Residential Areas	Unknown	Unknown
98	Building	16/11/1925	13/1/1926
99	Rubbish	26/7/1926	11/8/1926
100	Keeping of Animals	23/8/1926	17/11/1926
102	Traffic	30/4/1928	16/5/1928
103	Childrens Playgrounds	15/4/1929	22/5/1929
104	Traffic	21/1/1922	13/2/1923
105	Petrol Pumps	3/9/1929	2/10/1929
106	Driving Cattle	3/3/1930	2/4/1930
108	Traffic	28/7/1930	6/8/1930
109	Use of Buildings Classes of Trade	29/12/1930	Unknown
110	Erection and Use of Buildings Amending By-Law 107	10/11/1930	21/1/1931
111	Petrol Pumps Amending By-Law 105	30/12/1931	13/1/1932
112	Playgrounds — Victoria Street	8/5/1933	24/10/1934
113	Traffic — Parking	11/9/1933	27/9/1933
114	Signs & Hordings	31/1/1934	16/5/1934
116	No record	Unknown	Unknown
119	Good Order & Decency, Municipal Buildings	17/6/1935	17/7/1935
120	No record	Unknown	Unknown
121	No record	Unknown	Unknown
124	Alteration of Residential Area	13/12/1937	16/2/1938
125	Building	31/10/1938	21/2/1939
128	Residential Areas	24/6/1940	27/11/1940
130	Residential Areas	4/5/1942	6/1/1943
131	No record	Unknown	Unknown
132	No record	Unknown	Unknown
133	Residential Areas West Ward	17/5/1942	6/8/1943
134	Removal & Destruction of Refuse or Rubbish	7/2/1944	5/4/1944
137	Fees for Chilling Chambers	15/4/1946	17/7/1946
138	No record	Unknown	Unknown
139	No record	Unknown	Unknown
140	City Abattoirs Management	12/3/1948	4/8/1948
141	No record	Unknown	Unknown
143	No record	Unknown	Unknown
145	Residential Area No. 8	9/5/1949	10/8/1949
146	No record	Unknown	Unknown
147	Fees Abattoirs Chilling Chambers	7/11/1949	8/3/1950
148	No record	Unknown	Unknown
149	Residential Area No. 8	31/6/1950	27/9/1950

Number	Short Title or Description	Date of Council Confirmation	Date of Gazettal
150	No record	Unknown	Unknown
151	No record	Unknown	Unknown
152	No record	Unknown	Unknown
153	No record	Unknown	Unknown
154	Residential Area No. 8	24/9/1951	5/12/1951
155	Residential Areas	11/3/1952	18/6/1952
156	Residential Area No. 8	19/5/1952	18/6/1952
157	Residential Area No. 3	3/6/1952	18/6/1952
158	Street Traffic	11/2/1952	9/4/1952
159	Residential Area No. 3	21/4/1952	20/8/1952
160	Residential Area No. 11	11/8/1952	22/10/1952
161	Street Traffic	9/2/1953	Unknown
164	Abattoirs Fees	20/9/1954	26/1/1955
169	Derelict Vehicles	5/11/1958	16/12/1958
170	Standing Places for Motor Cars	15/12/1958	Unknown
173	Fees for Abattoirs & Chilling Chambers	31/1/1961	11/4/1961
175	Dog Act Fees	7/5/1962	6/6/1962
178	Playgrounds	9/8/1965	24/8/1965
179	Registration of Premises	20/11/1967	19/12/1967
181	No record	Unknown	Unknown
182	Fees for Abattoirs & Meat Inspection	28/3/1973	16/5/1973
183	Noise	12/8/1974	Unknown

Resolution for passing this By-Law agreed to by the Council on 8 August 1983 and confirmed on 5 September 1983.

SEALED WITH THE COMMON SEAL OF THE MAYOR, COUNCILLORS AND CITIZENS OF THE CITY OF RICHMOND, 8 September 1983, in the presence of

(SEAL) A. G. GILLON, Commissioner
D. G. WILLIAMS, Town Clerk 8805

BOROUGH OF PORT FAIRY

Change of Street Name

Notice is hereby given that by resolution of the Council dated 30 August 1983, the name of the road contained in certificate of titles Vol. 9498 Folio 096; Vol. 9405, Folio 460, and Vol. 9405, Folio 461 and being commonly known as Nagle Place, has been changed and will be henceforth named and known as Belfast Close.

I. C. PATIENCE, Town Clerk

8803

SHIRE OF BANNOCKBURN

Road Naming

Notice is given that the road east of Brunel Street which leads to the Lethbridge Recreation Lake in the Township of Lethbridge in the County of Grant, was named by Council on 8 September as "Reservoir Street".

K. L. SPILLER, Shire Secretary

8855

SHIRE OF BELLARINE

Pursuant to Section 535 of the *Local Government Act* 1958, the Council of the Shire of Bellarine resolved at a meeting held on 17 August 1983 that the name of the following road as set out hereunder be changed:

Old Name: Quarry Road.

New Name: Becks Road.

Locality: Drysdale.

G. L. PEARCE, Shire Manager

8819

SHIRE OF BULN BULN

Loan No. 128

Notice of Intention to Borrow the Sum of \$75 000 for Permanent Works and Undertakings

Notice is hereby given that the Council of the Shire of Buln Buln proposes to borrow the principal sum of \$75 000 secured by

a charge over the general rates of the municipality, such sum to be raised by the grant of a mortgage in accordance with the provisions of the *Local Government Act 1958*.

1. The maximum rate of interest that may be paid is 15·8 per cent per annum.

2. The purpose for which the loan is to be applied is — Purchase of Land — Parish of Jindivick — containing road-making materials (part cost).

3. The period of the loan shall be 15 years.

4. The moneys borrowed shall be repayable by providing out of the Municipal Fund half-yearly instalments of approximately \$6599.31 each including principal and interest on 1 November and 1 May during the currency of the loan. The first instalment shall be payable on 1 May 1984.

5. Such moneys shall be repayable to the Commissioners of the State Bank of Victoria at the office of the said Commissioners, 385 Bourke Street, Melbourne.

The plans and specifications and the estimate of the cost of the proposed works and a statement showing the proposed expenditure of the moneys to be borrowed are open for inspection at the office of the Council of the Shire of Buln Buln, at Drouin.

8806 K. A. PRETTY, Shire Secretary

Form 2.1

Town and Country Planning Act 1961

SHIRE OF BUNGAREE PLANNING SCHEME

Amendment No. 13

Notice that a Planning Scheme has been Prepared and is Available for Inspection

Notice is hereby given that the Shire of Bungaree in pursuance of its powers under the *Town and Country Planning Act 1961* has prepared a scheme for:—

the subdivision of Lot 1, L.P. 95178, Slatey Creek Road, Invermay into two allotments.

A copy of the scheme has been deposited at the Bungaree Shire Offices, Western Highway, Leigh Creek 3352, at the Office of the Department of Planning, State Government Offices, Corner Mair and Doveton Streets, Ballarat and at the Office of the Department of Planning (Plan Inspection Section), 5th Floor, 235 Queen Street, Melbourne, and will be open for inspection during office hours by any person free of charge.

Any persons affected by the scheme are required to set forth in writing any submission they may wish to make with respect to the scheme addressed to the Shire Secretary, Shire of Bungaree, Shire Offices, R.S.D., Leigh Creek 3352, by 14 October 1983 and state whether you wish to be heard in respect of your submission.

14 September 1983
8807 W. P. RUSSELL, Planning Officer

SHIRE OF COLAC

Loan No. 51

Notice of Intention to Borrow the Sum of \$150 000 for Permanent Works and Undertakings

Notice is hereby given that the Council of the Shire of Colac proposes to borrow the principal sum of One Hundred and Fifty Thousand Dollars secured by a charge over the general rates of the municipality, such sum to be raised by the grant of a mortgage in accordance with the provisions of the *Local Government Act 1958*.

1. The maximum rate of interest that may be paid is 15 per centum per annum.

2. The purpose for which the loan is to be applied is:—

	\$
Construction of Plant Sheds (Garages)	80 000
Construction of Workshop and Store	70 000
	\$150 000

3. The period of the loan shall be 4 years, based on a 15 year repayment schedule.

4. The moneys borrowed shall be repayable by providing out of the Municipal Fund 7 half-yearly instalments of approximately \$12 700.69 each including principal and interest on 28 April and 28 October each year during the currency of the loan and a final instalment of \$147 546.25 which includes principal and interest. The first instalment will be payable on 28 April 1984.

5. Such moneys shall be payable to the National Australia Savings Bank Ltd., Melbourne.

The plans, specifications and estimates of cost of the works and a statement showing the proposed expenditure of the money to be borrowed are open for inspection at the Office of the Council of the Shire of Colac, Shire Hall, Murray Street, Colac.

8808 W. J. MAUNSELL, Shire Secretary

Form 2.1

Town and Country Planning Act 1961

SHIRE OF FLINDERS PLANNING SCHEME 1962

Amendment No. 160, 1983

Notice that a Planning Scheme has been Prepared and is Available for Inspection

Notice is hereby given that the Council of the Shire of Flinders in pursuance of its powers under the *Town and Country Planning Act 1961* has prepared a scheme for the zoning of land described as Pt. Lots 1 and 13, L/P 119852, 1 and 2 Colchester Road, Rosebud, from Garden Industry Zone to Urban Related Industry Zone.

A copy of the scheme has been deposited at the office of the Shire of Flinders, Boneo Road, Rosebud, and at the office of the Department of Planning (Plan Inspection Section), 5th Floor, 235 Queen Street, Melbourne, and will be open for inspection during office hours by any person free of charge.

Any persons affected by the scheme are required to set forth in writing any submission they may wish to make with respect to the scheme addressed to:

The Shire Secretary, Shire of Flinders, P.O. Box 1000, Rosebud 3939

by 14 October 1983 and state whether you wish to be heard in respect of your submission.

7 September 1983
8840 G. W. WHITE, Shire Secretary

SHIRE OF MINHAMITE

Loan No. 17

Notice of Intention to Borrow the Sum of \$60 000 for Permanent Works and Undertakings

Notice is hereby given that the Council of the Shire of Minhamite proposes to borrow the principal sum of \$60 000 secured by a charge over the general rates of the municipality, such sum to be raised by the grant of a mortgage in accordance with the provisions of the *Local Government Act 1958*.

1. The maximum rate of interest that may be paid is 14·8% per annum.

2. The purposes for which the loan is to be applied is road reconstruction and kerbing and channelling (half-cost) in Russell Street, Macarthur.

3. The period of the loan shall be four years.

4. The money borrowed shall be repayable by providing out of the Municipal Fund seven half-yearly instalments of \$5030.91 and a final instalment of \$58 880.27 each including principal and interest on 1 May and 1 November during the currency of the loan. The first instalment shall be payable on 1 May 1984.

5. Such moneys shall be repayable to the National Australia Savings Bank Limited, 271/285 Collins Street, Melbourne.

The plans, specifications and estimate of the cost of the proposed works, and a statement showing the proposed expenditure of the moneys to be borrowed are open for inspection at the Shire Hall, Dawson Street, Hawkesdale, during office hours.
8846 R. J. TOWLER, Shire Secretary

**PLAN OF LOT 1
PART OF CROWN ALLOTMENT 13
SECTION 7
PARISH OF BUNGAMERO
COUNTY OF DELATITE**

SCALE
40 20 0 40 80 120
LENGTHS ARE IN METRES

Town and Country Planning Act 1961
**SHIRE OF MORNINGTON PLANNING SCHEME 1958
(AS AMENDED)**
Notice that a Planning Scheme has been Prepared and is Available for Inspection

Notice is hereby given that the Shire of Mornington in pursuance of its powers under the *Town and Country Planning Act 1961* has prepared a Scheme for the area bounded generally by Sunshine Avenue, Lempriere Avenue, Prescott Avenue and Irvine Avenue, Mount Martha, to rezone from Residential Low Density 1 to Residential Low Density 2 Zone.

A copy of the Scheme has been deposited at the Council Offices, 78 Queen Street, Mornington, and at the Office of the Department of Planning (Plan Inspection Section), 5th Floor, 235 Queen Street, Melbourne, and will be open for inspection during office hours by any person free of charge.

Any persons affected by the Scheme are required to set forth in writing any submission they may wish to make with respect to the Scheme addressed to Shire Secretary, P.O. Box 78, Mornington 3931, by 14 October 1983 and state whether you wish to be heard in respect of your submission.

8 September 1983
8841 D. G. COLLINGS, Shire Secretary

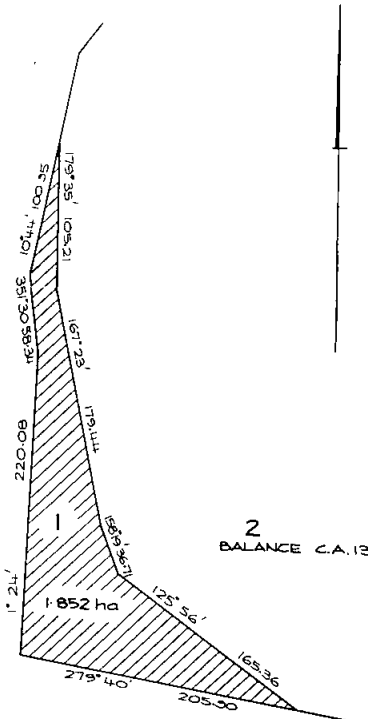

SHIRE OF OXLEY

Proclamation of Waterworks District and Urban District and Construction of Works for Supply of Water to the Township of Oxley.

Notice is hereby given that the Shire of Oxley has made application to the Honourable The Minister of Water Supply for the proclamation of a Waterworks District and Urban District and for the construction, maintenance and continuance of Water Supply Works within those Districts under the provisions of the Water Act.

A general plan and description of the proposed works have been submitted with the application, and copies of same may be seen at the Shire Office at 22 Rowan Street, Wangaratta.

Dated 7 September 1983
8670 E. F. VAN LEEUWEN, Shire Secretary

SHIRE OF OXLEY

DECLARATION OF PUBLIC HIGHWAY

Pursuant to the powers conferred by Section 522 of the *Local Government Act 1958*, the Council of the Shire of Oxley hereby directs that the land being part of Crown Allotment 19, Section 7, Parish of Bungamero, shown hatched on the plan hereunder which has been purchased or acquired by it shall be a Public Highway on and from the date of publication of this Order in the *Victoria Government Gazette*.

The Common Seal of the President, Councillors and Ratepayers of the Shire of Oxley was hereunto affixed on 7 September 1983 in the presence of:

(SEAL) T. G. WADLEY, President
A. C. SWINBURNE, Councillor
E. F. VAN LEEUWEN, Shire Secretary
8815

BALLAN WATERWORKS TRUST

Extension of Waterworks District, Proclamation of Urban District and Construction of Works for supply of Water to Blackwood

Notice is hereby given that the Ballan Waterworks Trust has made application to the Honourable, the Minister of Water Supply for the extension of its Waterworks Districts, proclamation of the Blackwood Urban District, and for the construction, maintenance and continuance of Water Supply Works within those Districts under the provision of the Water Act.

A general plan and description of the proposed works have been submitted with the application, and copies of same may be seen at the Trust's Office at Steiglitz Street, Ballan, or at the Blackwood Public Hall, Cnr. Golden Point & Byers Roads, Blackwood.

Dated at Ballan, 31 August 1983
8632 JEREMY JOHNSON, Trust Secretary

MOE SEWERAGE AUTHORITY

Plans have been prepared for the laying of sewer mains to serve the following streets in the City of Moe.

Job No. 111/189 Sewers to serve Stage 3 Ollerton Park.

The plans are available for inspection during normal working hours at the office of the Authority, 44 Albert Street, Moe.

8847 A. DEWAR, Secretary

FRANKSTON SEWERAGE AUTHORITY

DECLARATION OF SEWERED AREAS NOS. 269 TO 273
INCLUSIVE

That the Frankston Sewerage Authority having made provision for carrying off sewage from each and every property, which or any part of which is within the sewerage areas hereinafter described, doth hereby declare that on and after 1 October 1983, each and every property, which or any part of which is within the said sewerage areas, shall be deemed to be a seweraged property within the meaning of the *Sewerage Districts Act 1958*.

The boundaries of the sewerage areas hereinbefore referred to are:

Area No. 269

Commencing at the intersection of Silvertop Crescent and Silvertop Crescent, Frankston, on the boundary of Declared Area No. 52 then easterly along the boundaries of Declared Areas Nos. 52, 36 and 28 to the boundary of Declared Area No. 113 then southerly and westerly along the boundary of Declared Area No. 113 to the boundary of Declared Area No. 30 then northerly and north-westerly along the boundary of Declared Area No. 30 to the point of commencement. 51 houses and 5 vacant lots.

Area No. 270

Comprises Lots 287, 288, 289, 290 and 291 L.P.133750 Jinchilla Avenue, Frankston. 5 vacant lots.

Area No. 271

Commencing at the junction of Wattletree Lane and Lipton Drive, Frankston, on the boundary of Declared Area No. 110 then south-westerly along Lipton Drive to Narambi Crescent then north-westerly along Narambi Crescent to the south-eastern corner of Lot 188 L.P.90254 then westerly along the southern boundary of the said Lot 188 then north-westerly along the south-western boundaries of Lots 188 and 187, L.P.90254 and Lots 150 to 145 L.P.85409 inclusive then south-westerly along the south-eastern boundaries of Lots 142 and 141, L.P.85409, then westerly along the southern boundary of the said Lot 141 to Kimba Avenue, then generally south along Kimba Avenue to the boundary of Declared Area No. 65 then northerly, easterly and northerly along the boundaries of Declared Areas Nos. 65 and 49 to Cranbourne Road then east along Cranbourne Road to the boundary of Declared Area No. 207 then south and east along the boundary of Declared Area No. 207 to Wattletree Lane on the boundary of Declared Area No. 93 then south along the boundaries of Declared Area Nos. 93 and 110 to the point of commencement. 104 houses and 7 vacant lots.

Area No. 272

Comprises Lots 9, 10 and 11 L.P.97140 situated off Mein Place, Frankston. 2 houses and 1 vacant lot.

Area No. 273

Comprises Lot 38 L.P.40704 situated off Humphries Road, Frankston. 1 house.

By order of the said Authority

H. MAMERS, Chairman

8881

A. H. BUTLER, Secretary

Take notice that the partnership of Gary Norman Viccars and Betty Alma Viccars, the proprietors of the business known as "Victorian Kyokushin Karate Headquarters", situate at 159 Malop Street, Geelong is hereby dissolved as from 20 May 1983 as from such date the said Gary Norman Viccars will continue the business on his own account.

MESSRS. ANDREW SENIA AND ASSOC., solicitors, 94 Gheringhap Street, Geelong. 8789

The partnership of Messrs C. R. Dyer, H. S. Davies and J. A. Kelly who practiced under the name of Don & Edney, Solicitors, at 24-26 Riddell Parade, Elsternwick has been dissolved. Messrs C. R. Dyer and J. A. Kelly will continue to practice under the name of Don & Edney at new premises at 255 Glenhunty Road, Elsternwick. The post office box and telephone number of the firm remain unchanged. 8789

Notice is hereby given that the Partnership subsisting between Debra Lee Eccles and Peter John Eccles who carry on a business under the business name J.D. (Jewellery) Products at 90 Auburn Road, Hawthorn has been dissolved as at 1 July 1983. All debts due and owing by the said firm will be received and paid respectively by Peter John Eccles who will continue to carry on the business under the business name J.D. (Jewellery) Products.

RICHARDSON CULBARD JONES & CO, solicitors, of 499 St. Kilda Road, Melbourne. 8790

Companies Act 1961, Section 271

GILVOY (VIC.) PTY. LTD. (IN LIQUIDATION)

Notice of Meeting of Members and Creditors

Notice is hereby given that a general meeting of the members and creditors of Gilvoy (Vic.) Pty. Ltd. (In Liquidation) will be held at the offices of V. R. Dye & Co., Chartered Accountants, 159 Springvale Road, Nunawading 3131 on Monday 26 September 1983 at 11.00 a.m. to receive an account of my acts and dealings and of the conduct of the winding up during the year ended 27 June 1983.

Dated this 8 September 1983

8830

V. R. DYE, Liquidator

Companies Act 1961, Section 272 (2)

BRIAN ZOUCHE PUBLICATIONS PTY. LTD.

(IN LIQUIDATION)

Notice of Final Meeting

Notice is hereby given that pursuant to Section 272 (2) of the *Companies Act 1961* the Final Meeting of Members and Creditors of the Company will be held at 2nd Floor, 335 Flinders Lane, Melbourne on 15 October 1983 at 10.45 a.m. for the purpose of laying before the Meeting the account of the winding up and any explanation thereof.

Dated this 14 September 1983

PAUL M. O'REILLY, Liquidator, 335 Flinders Lane, Melbourne, Victoria 3000. 8831

The Companies Act 1961, Section 272

ADREM PTY. LTD. (IN LIQUIDATION)

Notice is hereby given that in pursuance of Section 272 of the *Companies Act 1961*, the Final Meeting of the members of the abovenamed Company will be held at the office of Wallace, McMullin & Smail, 499 St Kilda Road, Melbourne on Tuesday 11 October 1983 at 11.00 a.m.

Dated this 6 September 1983

8832

J. Y. ROBERTS, Liquidator

Unclaimed Moneys Act 1962

Register of Unclaimed Moneys held by the—

<i>Name of Owner on Books and Last Known Address</i>	<i>Total Amount Due to Owner</i>	<i>Description of Unclaimed Money</i>	<i>Date when Amount first became Payable</i>
\$			
BENNETT AND KESSNER PTY. LTD.			
Taylor, Shane	144.00	Loan	28.7.80
Green, T. W. and L. J., Old Sale Rd, Buln Buln 8801	37.50	Sale	4.6.77
Form 92 Companies Regulations			
SEPTHEY NOMINEES PTY. LTD. (RECEIVER AND MANAGER APPOINTED)			
Notice is hereby given that a meeting of creditors of Septhey Nominees Pty. Ltd., will be held at the Settling Room, The Victorian Club, 141 Queen Street, Melbourne, on Friday 16 September 1983 at 10.30 a.m. in the forenoon.			
<i>Agenda</i>			
1. To receive the Official Liquidator's Report.			
2. To fix the remuneration of the Official Liquidator.			
3. To consider, if thought fit, the appointment of members of a Committee of Inspection.			
Dated this 26 August 1983			
R. D. WIDDOWS, 703 South Road, Moorabbin 3189. Telephone 555 7430. 8820			
<i>The Companies Act 1961</i>			
BOARDGAMES WHOLESALE PTY. LTD. (IN LIQUIDATION)			
Notice is hereby given that a Meeting of Creditors of Boardgames Wholesale Pty. Ltd. (In Liquidation) will be held at the offices of Touche Ross & Co., 11th Floor, 440 Collins Street, Melbourne on 26 September 1983 at 3.00 p.m.			
<i>Agenda</i>			
1. To receive a report from the Liquidator on the Affairs of the Company and upon the progress of the winding up.			
2. To approve the remuneration of the Liquidator.			
3. Any other business.			
Dated this 7 September 1983			
8828 G. O. HARRISON, Liquidator			
<i>The Companies Act 1961</i>			
GILVOY (VIC.) PTY. LTD. (IN LIQUIDATION)			
Notice is hereby given that as Liquidator of the abovenamed company I have fixed Monday 26 September 1983 as the day on or before which creditors of the company are to prove their debts or claims and to establish any title they may have to priority under Section 292 or be excluded from the benefit of a first and final distribution made before such debts are proved or as the case may be from objecting to such distribution.			
Dated this 8 September 1983			
V. R. DYE, Liquidator			
V. R. DYE & CO., Chartered Accountants, 159 Springvale Road, Nunawading 3131. 8829			
DEVLIN CONSTRUCTIONS PTY. LTD. IN VOLUNTARY LIQUIDATION			
Notice of Extra-Ordinary General Meeting of Shareholders			
Notice is hereby given of a Meeting of Shareholders to be held at the office of Stannard, Coghlan & Jackson of 4th Floor, 457 St. Kilda Road, Melbourne on 10 October 1983 at 5.30 p.m.			
<i>Business</i>			
To receive the Liquidation Account of Receipts and Payments and Statement of the Position in the Winding Up. 8804			
<i>The Companies Act 1961</i>			
BOARDGAMES WHOLESALE PTY. LTD. (IN LIQUIDATION)			
Notice is hereby given that a first dividend is intended to be declared in the above matter. Creditors who have not proved their debts by 30 September 1983 may be excluded from this dividend.			
Dated this 7 September 1983			
G. O. HARRISON, Liquidator			
TOUCHE ROSS & CO., Chartered Accountants, 440 Collins Street, Melbourne 3000. 8822			
In the Supreme Court of Victoria, 1983 No. Co. 13279—In the matter of the Companies (Victoria) Code; and in the matter of A & W Industrial Sales Pty. Ltd.—Notice of Making of Winding Up Order—			
Notice is hereby given that on 1 September 1983 it was ordered that A & W Industrial Sales Pty. Ltd. be wound up and that Alfred Neville Bird, of 499 St Kilda Road, Melbourne be appointed Liquidator.			
Dated 5 September 1983			
TURNER, NESS & DAVIS, Solicitors acting as Melbourne Agents for the Applicant. 8824			
In the Supreme Court of Victoria, 1983 Co. No. 13281—In the matter of the Companies (Victoria) Code 1982; and in the matter of Iglu Australia Pty. Limited—Notice of Appointment of Liquidator			
In the matter of Iglu Australia Pty. Limited Order for the appointment of Liquidator made 1 September 1983.			
Name and Address of Liquidator, James Manson Poulton, care of Messrs. Peat Marwick Mitchell & Co., 500 Bourke Street, Melbourne.			
MESSRS. MADGWICKS			
MESSRS. MADGWICKS, of 440 Collins Street, Melbourne, Solicitors for the Petitioner. 8826			

In the Supreme Court of Victoria, 1983 Co. No. 13384—In the matter of the Companies (Victoria) Code; and in the matter of Curmor Pty. Ltd.; and in the matter of an Application by Mondial Trading Pty. Ltd.

Notice is hereby given that an Application for the winding up of the abovenamed company by the Supreme Court was on 24 August 1982 presented by Mondial Trading Pty. Ltd. and that the said Application is directed to be heard before the Court sitting at the Practice Court, Law Courts, Lonsdale Street, Melbourne at the hour of 10.30 o'clock in the forenoon on 13 October 1983 and any creditor or contributory of the said company desiring to support or oppose the making of an order on the said Application may appear at the time of hearing by himself or his Counsel for the purpose; and a copy of the said Application will be furnished to any creditor or contributory of the said company requiring the same by the undersigned on payment of the regulated charge for the same.

The Applicant's official address is 538 Collins Street, Melbourne, Victoria.

The Applicant's Solicitors are Messrs. Pavey Whiting & Byrne, of 360 Collins Street, Melbourne, Victoria.

PAVEY WHITING & BYRNE

Note—Any person who intends to appear on the hearing of the said Application must serve on or send by post to the abovenamed Pavey Whiting & Byrne, notice in writing of his intention so to do. The notice must state the name and address of the person, or, if a firm, the name and address of the firm, and must be signed by the person or firm, or his, or their solicitors (if any), and must be served, or, if posted, must be sent by post in sufficient time to reach the abovenamed not later than 4.00 o'clock in the afternoon of 12 October 1983.

8842

In the Supreme Court of Victoria, 1983 Co. No. 13385—In the matter of the Companies (Victoria) Code; and in the matter of R.C. & V.M. Investments Pty. Ltd.; and in the matter of an Application by Mondial Trading Pty. Ltd.

Notice is hereby given that an Application for the winding up of the abovenamed company by the Supreme Court was on 24 August 1982 presented by Mondial Trading Pty. Ltd. and that the said Application is directed to be heard before the Court sitting at the Practice Court, Law Courts, Lonsdale Street, Melbourne at the hour of 10.30 o'clock in the forenoon on 13 October 1983 and any creditor or contributory of the said company desiring to support or oppose the making of an order on the said Application may appear at the time of hearing by himself or his Counsel for the purpose; and a copy of the said Application will be furnished to any creditor or contributory of the said company requiring the same by the undersigned on payment of the regulated charge for the same.

The Applicant's official address is 538 Collins Street, Melbourne, Victoria.

The Applicant's Solicitors are Messrs. Pavey Whiting & Byrne, of 360 Collins Street, Melbourne, Victoria.

PAVEY WHITING & BYRNE

Note—Any person who intends to appear on the hearing of the said Application must serve on or send by post to the abovenamed Pavey Whiting & Byrne, notice in writing of his intention so to do. The notice must state the name and address of the person, or, if a firm, the name and address of the firm, and must be signed by the person or firm, or his, or their solicitors (if any), and must be served, or, if posted, must be sent by post in sufficient time to reach the abovenamed not later than 4.00 o'clock in the afternoon of 12 October 1983.

8843

In the Supreme Court of Victoria, C.O. 13438—In the matter of the Companies (Victoria) Code; and in the matter of Mathkin Truck Sales Pty. Ltd.

Notice is hereby given that a petition for the winding up of the above-named Company by the Supreme Court was on 8 September 1983 presented by Eric John Unger, Deputy Commissioner of Taxation of the Commonwealth of Australia, and that the said petition is directed to be heard before the Court sitting at the Fifteenth Court, Law Courts, Lonsdale Street, Melbourne at the hour of 10.30 o'clock in the forenoon on 24 November 1983 and any creditor or contributory of the said Company desiring to support or oppose the making of an order on the said petition may appear at the time of hearing by himself or his Counsel for the purpose; and a copy of the said petition will be furnished to any creditor or contributory of the said Company requiring the same by the undersigned on payment of the regulated charge for the same.

The Petitioner's official address is: 350 Collins Street, Melbourne.

The Petitioner's Solicitor is: T. A. Sherman, Acting Crown Solicitor for the Commonwealth, of 200 Queen Street, Melbourne.

T. A. SHERMAN

Note—Any person who intends to appear on the hearing of the said petition must serve on or send by post to the abovenamed T. A. Sherman notice in writing of his intention to do so. The notice must state the name and address of the person, or, if a firm, the name and address of the firm, and must be signed by the person or firm, or his or their solicitor (if any), and must be served, or, if posted, must be sent by post in sufficient time to reach the abovenamed not later than 4.00 in the afternoon of 23 November 1983.

8864

In the Supreme Court of Victoria, C.O. 13439—In the matter of the Companies (Victoria) Code; and in the matter of David Michael (Properties) Proprietary Limited

Notice is hereby given that a petition for the winding up of the above-named Company by the Supreme Court was on 8 September 1983 presented by Eric John Unger, Deputy Commissioner of Taxation of the Commonwealth of Australia, and that the said petition is directed to be heard before the Court sitting at the Fifteenth Court, Law Courts, Lonsdale Street, Melbourne at the hour of 10.30 o'clock in the forenoon on 24 November 1983 and any creditor or contributory of the said Company desiring to support or oppose the making of an order on the said petition may appear at the time of hearing by himself or his Counsel for the purpose; and a copy of the said petition will be furnished to any creditor or contributory of the said Company requiring the same by the undersigned on payment of the regulated charge for the same.

The Petitioner's official address is: 350 Collins Street, Melbourne.

The Petitioner's Solicitor is: T. A. Sherman, Acting Crown Solicitor for the Commonwealth, of 200 Queen Street, Melbourne.

T. A. SHERMAN

Note—Any person who intends to appear on the hearing of the said petition must serve on or send by post to the abovenamed T. A. Sherman notice in writing of his intention to do so. The notice must state the name and address of the person, or, if a firm, the name and address of the firm, and must be signed by the person or firm, or his or their solicitor (if any), and must be served, or, if posted, must be sent by post in sufficient time to reach the abovenamed not later than 4.00 in the afternoon of 23 November 1983.

8865

In the Supreme Court of Victoria, C.O. 13436—In the matter of the Companies (Victoria) Code; and in the matter of Import (Sport) Pty. Limited

Notice is hereby given that a petition for the winding up of the above-named Company by the Supreme Court was on 8 September 1983 presented by Eric John Unger, Deputy Commissioner of Taxation of the Commonwealth of Australia, and that the said petition is directed to be heard before the Court sitting at the Fifteenth Court, Law Courts, Lonsdale Street, Melbourne at the hour of 10.30 o'clock in the forenoon on 24 November 1983 and any creditor or contributory of the said Company desiring to support or oppose the making of an order on the said petition may appear at the time of hearing by himself or his Counsel for the purpose; and a copy of the said petition will be furnished to any creditor or contributory of the said Company requiring the same by the undersigned on payment of the regulated charge for the same.

The Petitioner's official address is: 350 Collins Street, Melbourne.

The Petitioner's Solicitor is: T. A. Sherman, Acting Crown Solicitor for the Commonwealth, of 200 Queen Street, Melbourne.

T. A. SHERMAN

Note—Any person who intends to appear on the hearing of the said petition must serve on or send by post to the abovenamed T. A. Sherman notice in writing of his intention to do so. The notice must state the name and address of the person, or, if a firm, the name and address of the firm, and must be signed by the person or firm, or his or their solicitor (if any), and must be served, or, if posted, must be sent by post in sufficient time to reach the abovenamed not later than 4.00 in the afternoon of 23 November 1983. 8862

In the Supreme Court of Victoria, C.O. 13440—In the matter of the Companies (Victoria) Code; and in the matter of Lonsdale Promotions Pty. Ltd.

Notice is hereby given that a petition for the winding up of the above-named Company by the Supreme Court was on 8 September 1983 presented by Eric John Unger, Deputy Commissioner of Taxation of the Commonwealth of Australia, and that the said petition is directed to be heard before the Court sitting at the Fifteenth Court, Law Courts, Lonsdale Street, Melbourne at the hour of 10.30 o'clock in the forenoon on 1 December 1983 and any creditor or contributory of the said Company desiring to support or oppose the making of an order on the said petition may appear at the time of hearing by himself or his Counsel for the purpose; and a copy of the said petition will be furnished to any creditor or contributory of the said Company requiring the same by the undersigned on payment of the regulated charge for the same.

The Petitioner's official address is: 350 Collins Street, Melbourne.

The Petitioner's Solicitor is: T. A. Sherman, Acting Crown Solicitor for the Commonwealth, of 200 Queen Street, Melbourne.

T. A. SHERMAN

Note—Any person who intends to appear on the hearing of the said petition must serve on or send by post to the abovenamed T. A. Sherman notice in writing of his intention to do so. The notice must state the name and address of the person, or, if a firm, the name and address of the firm, and must be signed by the person or firm, or his or their solicitor (if any), and must be served, or, if posted, must be sent by post in sufficient time to reach the abovenamed not later than 4.00 in the afternoon of 30 November 1983. 8866

In the Supreme Court of Victoria, C.O. 13437—In the matter of the Companies (Victoria) Code; and in the matter of Webb Warships Pty. Ltd.

Notice is hereby given that a petition for the winding up of the above-named Company by the Supreme Court was on 8 September 1983 presented by Eric John Unger, Deputy Commissioner of Taxation of the Commonwealth of Australia, and that the said petition is directed to be heard before the Court sitting at the Fifteenth Court, Law Courts, Lonsdale Street, Melbourne at the hour of 10.30 o'clock in the forenoon on 24 November 1983 and any creditor or contributory of the said Company desiring to support or oppose the making of an order on the said petition may appear at the time of hearing by himself or his Counsel for the purpose; and a copy of the said petition will be furnished to any creditor or contributory of the said Company requiring the same by the undersigned on payment of the regulated charge for the same.

The Petitioner's official address is: 350 Collins Street, Melbourne.

The Petitioner's Solicitor is: T. A. Sherman, Acting Crown Solicitor for the Commonwealth, of 200 Queen Street, Melbourne.

T. A. SHERMAN

Note—Any person who intends to appear on the hearing of the said petition must serve on or send by post to the abovenamed T. A. Sherman notice in writing of his intention to do so. The notice must state the name and address of the person, or, if a firm, the name and address of the firm, and must be signed by the person or firm, or his or their solicitor (if any), and must be served, or, if posted, must be sent by post in sufficient time to reach the abovenamed not later than 4.00 in the afternoon of 23 November 1983. 8863

In the Supreme Court of Victoria, C.O. 13441—In the matter of the Companies (Victoria) Code; and in the matter of Australian Bicycle Company Pty. Ltd.

Notice is hereby given that a petition for the winding up of the above-named Company by the Supreme Court was on 8 September 1983 presented by Eric John Unger, Deputy Commissioner of Taxation of the Commonwealth of Australia, and that the said petition is directed to be heard before the Court sitting at the Fifteenth Court, Law Courts, Lonsdale Street, Melbourne at the hour of 10.30 o'clock in the forenoon on 1 December 1983 and any creditor or contributory of the said Company desiring to support or oppose the making of an order on the said petition may appear at the time of hearing by himself or his Counsel for the purpose; and a copy of the said petition will be furnished to any creditor or contributory of the said Company requiring the same by the undersigned on payment of the regulated charge for the same.

The Petitioner's official address is: 350 Collins Street, Melbourne.

The Petitioner's Solicitor is: T. A. Sherman, Acting Crown Solicitor for the Commonwealth, of 200 Queen Street, Melbourne.

T. A. SHERMAN

Note—Any person who intends to appear on the hearing of the said petition must serve on or send by post to the abovenamed T. A. Sherman notice in writing of his intention to do so. The notice must state the name and address of the person, or, if a firm, the name and address of the firm, and must be signed by the person or firm, or his or their solicitor (if any), and must be served, or, if posted, must be sent by post in sufficient time to reach the abovenamed not later than 4.00 in the afternoon of 30 November 1983. 8867

In the Supreme Court of Victoria, C.O. 13442—In the matter of the Companies (Victoria) Code; and in the matter of Central Bricklaying Pty. Ltd.

Notice is hereby given that a petition for the winding up of the above-named Company by the Supreme Court was on 8 September 1983 presented by Eric John Unger, Deputy Commissioner of Taxation of the Commonwealth of Australia, and that the said petition is directed to be heard before the Court sitting at the Fifteenth Court, Law Courts, Lonsdale Street, Melbourne at the hour of 10.30 o'clock in the forenoon on 1 December 1983 and any creditor or contributory of the said Company desiring to support or oppose the making of an order on the said petition may appear at the time of hearing by himself or his Counsel for the purpose; and a copy of the said petition will be furnished to any creditor or contributory of the said Company requiring the same by the undersigned on payment of the regulated charge for the same.

The Petitioner's official address is: 350 Collins Street, Melbourne.

The Petitioner's Solicitor is: T. A. Sherman, Acting Crown Solicitor for the Commonwealth, of 200 Queen Street, Melbourne.

T. A. SHERMAN

Note—Any person who intends to appear on the hearing of the said petition must serve on or send by post to the abovenamed T. A. Sherman notice in writing of his intention to do so. The notice must state the name and address of the person, or, if a firm, the name and address of the firm, and must be signed by the person or firm, or his or their solicitor (if any); and must be served, or, if posted, must be sent by post in sufficient time to reach the abovenamed not later than 4.00 in the afternoon of 30 November 1983. 8868

In the Supreme Court of Victoria, C.O. 13443—In the matter of the Companies (Victoria) Code; and in the matter of Mercantile Futures Pty. Ltd.

Notice is hereby given that a petition for the winding up of the above-named Company by the Supreme Court was on 8 September 1983 presented by Eric John Unger, Deputy Commissioner of Taxation of the Commonwealth of Australia, and that the said petition is directed to be heard before the Court sitting at the Fifteenth Court, Law Courts, Lonsdale Street, Melbourne at the hour of 10.30 o'clock in the forenoon on 1 December 1983 and any creditor or contributory of the said Company desiring to support or oppose the making of an order on the said petition may appear at the time of hearing by himself or his Counsel for the purpose; and a copy of the said petition will be furnished to any creditor or contributory of the said Company requiring the same by the undersigned on payment of the regulated charge for the same.

The Petitioner's official address is: 350 Collins Street, Melbourne.

The Petitioner's Solicitor is: T. A. Sherman, Acting Crown Solicitor for the Commonwealth, of 200 Queen Street, Melbourne.

T. A. SHERMAN

Note—Any person who intends to appear on the hearing of the said petition must serve on or send by post to the abovenamed T. A. Sherman notice in writing of his intention to do so. The notice must state the name and address of the person, or, if a firm, the name and address of the firm, and must be signed by the person or firm, or his or their solicitor (if any), and must be served, or, if posted, must be sent by post in sufficient time to reach the abovenamed not later than 4.00 in the afternoon of 30 November 1983. 8869

In the Supreme Court of Victoria, 1983 No. Co. 13381—In the matter of the Companies (Victoria) Code; and in the matter of Computer Country (Nationwide) Pty. Ltd.

Notice is hereby given that a Petition for the winding up of the above-named company by the Supreme Court was on 19 August 1983 presented by the Petitioner, Computer Country (Nationwide) Pty. Ltd., and that the said Petition is directed to be heard before the Supreme Court sitting at Melbourne at the hour of 10.30 o'clock in the forenoon on 13 October 1983 and any creditor or contributory of the said company desiring to support or oppose the making of an order on the said Petition may appear at the time of the hearing by himself or his Counsel for that purpose; and a copy of the Petition will be furnished to any creditor or contributory of the said company requiring the same by the undersigned on payment of the regulated charge for the same.

The Petitioner's address is Ground Floor, 338 Queen Street, Melbourne.

The Petitioner's solicitors are Messrs. MacNab & Archer, of 7th Floor, 491 Bourke Street, Melbourne.

MACNAB & ARCHER

Note—Any person who intends to appear on the hearing of the said Petition must serve on or send by post to the above-named Messrs. MacNab & Archer notice in writing of his intention so to do. The notice must state the name and address of the person, or, if a firm, the name and address of the firm and must be signed by the person or the firm or his or their solicitor (if any) and must be served, or if posted, must be sent by post in sufficient time to reach the above-named no later than 4.00 o'clock in the afternoon of 12 October 1983. 8849

In the Supreme Court of Victoria, 1983 No. Co. 13404—In the matter of the Companies (Victoria) Code; and in the matter of Craidon Homes Pty. Limited

Notice is hereby given that a petition for the winding up of the above-named company by the Supreme Court was, on 1 September 1983, presented by Lauri Edwin Penttila and that the said petition is directed to be heard before the Court sitting at Melbourne at the hour of 10.30 in the forenoon, on 20 October 1983; and any creditor or contributory of the said company desiring to support or oppose the making of an order on the said petition may appear at the time of hearing by himself or his Counsel for that; and a copy of the petition will be furnished to any creditor or contributory of the said company requiring the same by the undersigned on payment of the regulated charge for the same.

The Petitioner's address is 867 Sydney Road, Moreland 3058.

The Petitioner's Solicitors are Messrs. Penttila & Co., of 867 Sydney Road, Moreland 3058.

MR. LAURI EDWIN PENTTILA

Note—Any person who intends to appear on the hearing of the said petition must serve on or send by post to the above-named petitioner or his Solicitors notice in writing of his intention to do so. The notice must state the name and address of the person, or, if a firm, the name and address of the firm, and must be signed by the person or firm, or his or their Solicitor (if any) and must be served, or if posted, must be sent by post in sufficient time to reach the above-named not later than four o'clock in the afternoon of 19 October 1983 (the day before the day appointed for the hearing of the Petition or the Friday preceding the day appointed for the hearing of the Petition if such day is a Monday or a Tuesday following a public holiday. 8850

Companies (Victoria) Code
NOTICE OF MEETING OF MEMBERS PURSUANT TO
SECTION 411

Notice is hereby given that pursuant to Section 411 of the Companies (Victoria) Code the final meeting of members of Gurney Investments Pty. Ltd. (In Voluntary Liquidation) will be held at the office of Messrs. Middletons, Oswald Burt & Co., 140 William Street, Melbourne on Monday 10 October 1983 at 9.00 a.m. for the purposes of laying before the meeting the Liquidator's final account and report and giving any explanation thereof.

Dated this 26 August 1983

8851 K. T. M. ROUTLEY, Liquidator

In the Supreme Court of Victoria, C.O. 13288—In the matter of the Companies (Victoria) Code; and in the matter of Travel Vision Pty. Ltd.—Notice of Winding-Up Order

Winding-Up Order: Made 8 September 1983.

Name and address of Liquidator: Douglas Orson Oldfield, 35 Collins Street, Melbourne, Victoria 3000.

T. A. SHERMAN, Acting Crown Solicitor for the Commonwealth and Solicitor for the Petitioner. 8857

In the Supreme Court of Victoria, 1983 No. Co. 13283—In the matter of the Companies (Victoria) Code; and in the matter of P. & P. Transport Pty. Ltd.—Before the Honourable Mr Justice Starke, 25 August 1983

Upon the Petition of South Coast Oils (Queensland and New South Wales) Pty. Limited on 29 June 1983 proffered unto the Court coming on to be heard before this Court on this day and upon hearing Mr Alston of Counsel for the Petitioner there being no appearance for the abovenamed Company and upon reading the said Petition, the Affidavit of John Douglas Bonnor sworn 24 June 1983 and the Affidavit of Andrea Judith Tabart sworn 14 July 1983 respectively all filed herein and the exhibits thereto and the Master's Certificate issued 18 August 1983 this Court doth order:—

1. That the abovenamed Company be wound up by the Court under the provisions of the Companies (Victoria) Code.

2. That Anthony George Hodgson be appointed liquidator for the purposes of the winding up.

3. That the bank in which the liquidator is to open a trust account be the branch of the Westpac Banking Corporation Limited at 447 Collins Street, Melbourne.

By the Court S. S. BREW, Master

Entered 6 September 1983

P. E. LEWIS, Deputy Prothonotary

Note—It will be the duty of such of the persons as are liable to make out or concur in making out a statement of affairs as the Liquidator may require to attend on him at such time and place as he may appoint and to give him all information he may require. 8848

The Companies Act 1961

EUROPE SPORTSWEAR PTY. LTD. (IN LIQUIDATION)
Notice Convening Final Meeting of the Company Pursuant to
Section 272 (1)

Notice is hereby given that the Final Meeting of Members and Creditors of the abovenamed Company will be held at the offices of Touche Ross & Co., 12th Floor, 440 Collins Street, Melbourne, Victoria on 12 October 1983 at 10.30 a.m. for the purpose of laying before the Meeting an account showing how the winding up has been conducted and the property of the Company has been disposed of and giving any explanation thereof.

Dated this 6 September 1983

G. O. HARRISON and R. M. H. COLE, Joint and Several Liquidators. 8833

In the Supreme Court of Victoria, C.O. 13284—In the matter of the Companies (Victoria) Code; and in the matter of S. Hunter & Associates Pty. Ltd.—Notice of Winding-Up Order

Winding-Up Order: Made 8 September 1983.

Name and address of Liquidator: Alan Murray Horsborough, 499 St Kilda Road, Melbourne, Victoria 3000.

T. A. SHERMAN, Acting Crown Solicitor for the Commonwealth and Solicitor for the Petitioner. 8858

In the Supreme Court of Victoria, C.O. 13285—In the matter of the Companies (Victoria) Code; and in the matter of Janval Distributors Pty. Limited—Notice of Winding-Up Order

Winding-Up Order: Made 8 September 1983.

Name and address of Liquidator: Ian Kenneth MacKinnon, 4th Floor, 576 St Kilda Road, Melbourne, Victoria 3004.

T. A. SHERMAN, Acting Crown Solicitor for the Commonwealth and Solicitor for the Petitioner. 8859

In the Supreme Court of Victoria, C.O. 13286—In the matter of the Companies (Victoria) Code; and in the matter of Master Spares Pty. Ltd.—Notice of Winding-Up Order

Winding-Up Order: Made 8 September 1983.

Name and address of Liquidator: Ernest Harding Niemann, 80 Collins Street, Melbourne, Victoria 3000.

T. A. SHERMAN, Acting Crown Solicitor for the Commonwealth and Solicitor for the Petitioner. 8860

In the Supreme Court of Victoria, C.O. 13287—In the matter of the Companies (Victoria) Code; and in the matter of Nine George Court Pty. Ltd.—Notice of Winding-Up Order

Winding-Up Order: Made 8 September 1983.

Name and address of Liquidator: Michael Joseph O'Keefe, 66 High Street, Glen Iris, Victoria 3146.

T. A. SHERMAN, Acting Crown Solicitor for the Commonwealth and Solicitor for the Petitioner. 8861

In the Supreme Court of Victoria, 1983 Co. No. 13399—In the matter of the Companies (Victoria) Code; and in the matter of Fun and Leisure Products Pty. Ltd.—Advertisement of Application

Notice is hereby given that an Application for the Winding Up of the abovenamed Company by the Supreme Court was on 30 August 1983 presented by Fiber Glass International Pty. Ltd. and that the said Application is directed to be heard before the Court sitting at the Practice Court, Law Courts, Lonsdale Street, Melbourne at the hour of 10.30 o'clock in the forenoon on 20 October 1983 and any Creditor or contributory of the said Company desiring to support or oppose the making of an Order on the said Application may appear at the time of hearing by himself or his Counsel for the purpose; and a copy of the said Application will be furnished to any Creditor or contributory of the said Company requiring the same by the undersigned on payment of the regulated charge for the same.

The Applicant's official address is 277 Dundas Street, Preston.

The Applicant's Solicitors are Messrs. McKean & Park with Pitcher & Butt, of 2nd Floor, 450 Little Collins Street, Melbourne.

McKEAN & PARK WITH PITCHER & BUTT

Note—Any person who intends to appear on the hearing of the said Application must serve on or send by post to the abovenamed McKean & Park with Pitcher & Butt notice in writing of its intention to do so. The Notice must state the name and address of the person or if a firm the name and address of the firm and must be signed by the person or firm or his or their Solicitors (if any) and must be served or if posted must be sent by post in sufficient time to reach the abovenamed not later than 4.00 o'clock in the afternoon of 19 October 1983. 8823

In the Supreme Court of Victoria, C.O. 13400—In the matter of the Companies (Victoria) Code 1981; and in the matter of Dawfran Pty. Ltd.

Notice is hereby given that a Petition for the winding up of the abovenamed company by the Supreme Court was, on 31 August 1983, presented by Poulos Bros. (Wholesale) Pty. Ltd. and that the said Petition is directed to be heard before the Court sitting at Law Courts, William Street, Melbourne at the hour of 10.30 o'clock on 20 October 1983; and any Creditor or contributory of the said company desiring to support or oppose the making of an Order on the said Petition may appear at the time of hearing by himself or his Counsel for that purpose; and a copy of the Petition will be furnished to any Creditor or Contributory of the said Company requiring same by the undersigned on payment of the regulated charge for same.

The Petitioner's address is 1-3 Lord Street, Botany, in the State of New South Wales.

The Petitioner's solicitors are Messrs. Haines and Polites, of 8th Floor, 150 Queen Street, Melbourne.

HAINES & POLITES

Note—Any person who intends to appear on the hearing of the said Petition must serve on or send by post to the abovenamed Messrs. Haines and Polites Notice in writing of his intention to do so. The Notice must state the name and address of the person, or if a firm, the name and address of the firm and must be signed by the person or firm, or his or their solicitor (if any), and must be served, or, if posted, must be sent by post in sufficient time to reach the abovenamed not later than 4.00 o'clock in the afternoon of 19 October 1983.

8810

Companies (Victoria) Code

M.B.F. CARRIERS (GEELONG) PTY. LTD.

Notice is hereby given that at an Extraordinary General Meeting of Members of the abovenamed company held on 2 September 1983 it was resolved that the company be wound up voluntarily and that Mr Russell Graeme Peake, Chartered Accountant and Registered Liquidator, of Day, Neilson, Jenkins & Johns, Chartered Accountants, 177 Moorabool Street, Geelong be appointed Liquidator.

Dated at Geelong, 6 September 1983

8811

D. FIELDER, Director

BOOROONDARA HOME SITES CO-OPERATIVE NO. 1 LTD. (IN LIQUIDATION)

Notice of Final Meeting of Members and Creditors pursuant to Section 192 of the *Co-operation Act* 1981 and Section 272 of the *Companies Act* 1961.

Notice is hereby given that the final meeting of Members and Creditors of Booroondara Home Sites Co-operative No. 1 Ltd. (In Liquidation) will be held at the meeting room of the Toorak/South Yarra Library, 338 Toorak Road, South Yarra on Thursday 13 October 1983 at 5.30 p.m.

Agenda

1. To receive from the Liquidator his final accounts showing how the winding up has been conducted and the property of the Co-operative disposed of and receiving any explanation thereof.
2. To propose and if thought fit, pass the following resolution: "That the books and records of the Co-operative be destroyed at the expiration of six months after the date of the final meeting."

Dated this 12 September 1983

M. A. Webb & Co.,
4th Floor,
286 Toorak Road,
South Yarra 3141

8870

MICHAEL A. COPPINS, Liquidator

The Companies Act 1961

B.N.C. APPLIANCES PTY. LTD. (IN LIQUIDATION)

Notice is hereby given that a first dividend is intended to be declared in the above matter. Creditors who have not proved their debts by 30 September 1983 may be excluded from this dividend.

Dated this 13 September 1983

Touche Ross & Co.,
Chartered Accountants,
440 Collins Street,
Melbourne 3000.

G. O. HARRISON and R. M. H. COLE, Joint and Several Liquidators. 8871

In the Supreme Court of Victoria, 1983 Co. No. 13282—In the matter of the Companies (Victoria) Code 1982; and in the matter of Cotarex Australia Pty. Limited—Notice of Appointment of Liquidator

In the matter of Cotarex Australia Pty. Limited Order for the appointment of Liquidator made 1 September 1983.

Name and Address of Liquidator, Warwick Allen Leeming, care of Messrs. Duesburys, 114 William Street, Melbourne.

MESSRS. MADGWICKS

MESSRS. MADGWICKS, of 440 Collins Street, Melbourne, Solicitors for the Petitioner. 8825

In the Supreme Court of Victoria, C.O. 197897A—In the matter of the Companies (Victoria) Code 1982; and in the matter of Afrad Pty. Ltd.

Notice is hereby given that a petition for the winding up of the abovenamed Company by the Supreme Court was on 18 August 1983 presented by Statewide Commercial Carpets Pty. Ltd. and that the said petition is directed to be heard before the Court sitting at the Practice Court, Law Courts, Lonsdale Street, Melbourne, at the hour of 10.30 a.m. on 13 October 1983 and any creditor or contributory of the said company desiring to support or oppose the making of an order on the said petition may appear at the time of hearing by himself or his counsel for that purpose; and a copy of the petition will be furnished to any creditor or contributory of the said company requiring the same by the undersigned on payment of the regulated charge for the same.

The Petitioner's address is 19A Queen Street, Mitcham in the State of Victoria.

The Petitioner's Solicitors are Messrs Harle and Murphy, of 112 James Street, Templestowe.

HARLE & MURPHY

Note—Any person who intends to appear on the hearing of the said petition must serve on or send by post to the abovenamed Harle and Murphy notice in writing of his intention so to do. The notice must state the name and address of the person or, if a firm, the name and address of the firm, and must be signed by the person or firm or his or their solicitor (if any), and must be served or, if posted, must be sent by post in sufficient time to reach the abovenamed not later than four o'clock in the afternoon of 12 October 1983 (the day before the day appointed for the hearing of the petition). 8791

ALFRED ERNEST MONCRIEFF, late of 1 Flett Street, Preston, retired, deceased

Creditors, next of kin and others having claims in respect of the estate of the deceased, who died on 30 March 1982, are required to send particulars of their claims to Donald Claude Moncrieff care of Walsh, Johnston & Co., solicitors, 452 High Street, Northcote before 9 November 1983 after which date he will distribute the assets having regard only to the claims of which he then has notice.

WALSH, JOHNSTON & CO., solicitors, 452 High Street, Northcote. 8800

Creditors, next of kin or others having claims in respect of the estate of Alice Amy Pell late of Kyabram deceased who died on 2 February 1983 are to send particulars of their claims to the Executors care of the under-mentioned Solicitors by 22 November 1983 after which date the Executors will distribute the assets having regard only to the claims of which they then have notice.

MORRISON AND SAWERS, Kyabram, solicitors for the executors 8882

Creditors, next of kin and others having claims in respect of the Estate of Aileen Mary Higgins, late of 13 Cameron Road, Essendon in the State of Victoria, married woman, deceased intestate, who died on 4 April 1983, are required by the Administrator of the Estate George Wallace Higgins, of 13 Cameron Road, Essendon in the said State of Victoria, retired, to send particulars to N. C. Gay & Co., solicitors, of 136 Sydney Road, Brunswick by 30 November 1983 after which date the said Administrator may distribute the assets having regard only to claims of which he then has notice.

N. C. GAY & CO., solicitors, 136 Sydney Road, Brunswick. 8796

LEWIS, DOROTHY VERA, late of 23 Victoria Avenue, Canterbury, widow

Creditors, next of kin and others having claims in respect of the estate of the deceased (who died on 23 July 1983) are required by The Perpetual Executors and Trustees Association of Australia Limited, of 50 Queen Street, Melbourne to send particulars of their claims to the said Company by 24 November 1983 after which date it will convey or distribute the assets, having regard only to the claims of which the Company then has notice.

HENDERSON & BALL, 430 Little Collins Street, Melbourne. 8812

Creditors, next of kin and others having claims in respect of the Estate of Thomas Douglas Williamson, late of 19 Byron Street, Elwood, retired, deceased, who died on 26 May 1983 and Probate of whose Will has been granted to Dulcie Marguerite Williamson, of 19 Byron Street, Elwood, widow, are required to send particulars of their claims to the said Executrix care of the undermentioned Solicitors by 14 November 1983 after which date she will distribute the assets having regard only to the claims of which she then has notice.

PEARCE & WEBSTER, solicitors, 430 Little Collins Street, Melbourne. 8813

Creditors, next of kin and others having claims against the estate of James Hope, late of Barton Avenue, Marysville, Forests Commission employee, deceased, who died on 14 April 1983, are required by the Executrix, Athlea Hope, to send particulars of their claims in writing to her care of the undermentioned firm of solicitors by 21 November 1983 after which date the executrix will distribute the assets having regard only to the claims of which she then has notice.

MAL. RYAN, JACKSON & GLEN, solicitors, 81 Grant Street, Alexandra. 8814

JOHN GOULD TAYLOR GUILFOYLE, late of "Yatama" Penshurst, farmer, deceased

Creditors, next of kin and others having claims in respect of the estate of the abovenamed deceased (who died on 17 May 1983) are required to send particulars of their claims to the executors Helen Lewis Guilfoyle of "Yatama" Penshurst, widow and Robert Russell Aitken of 114 William Street, Melbourne, solicitor care of the undermentioned solicitors by the 15 November 1983 after which date they may convey or distribute the assets having regard only to the claims of which they then have notice.

AITKEN WALKER & STRACHAN, solicitors, 114 William Street, Melbourne 3000. 8792

Creditors, next of kin and others having claims against the Estate of Lorna Katherine Scott Playle, late of 37 Rockbeare Grove, Ivanhoe in the State of Victoria, married woman, deceased, who died on 3 July 1983, are required by the Executor, The Union-Fidelity Trustee Company of Australia Limited, of 100 Exhibition Street, Melbourne to send particulars of their claims addressed to the said Executor, The Union-Fidelity Trustee Company of Australia Limited, of 100 Exhibition Street, Melbourne aforesaid before 14 November 1983 after which date the said Company will distribute the Estate having regard only to the claims of which it then has notice.

ROMUALD J. MARTIN, of 100 Exhibition Street, Melbourne, solicitor. 8816

KAZYS JANKUS, late of Begonia Nursing Home, 207-215 Richards Street, Ballarat East in the State of Victoria, pensioner, deceased

Creditors, next of kin and others having claims in respect of the estate of the deceased, who died on 9 October 1982, are required by the executors, Russell James Higgins and Miro Schimana, both of 47 Yarra Street, Geelong in the State of Victoria, solicitors, to send particulars to them care of Price, Higgins & Fidge, 47 Yarra Street, Geelong aforesaid by 20 November 1983 after which the executors may distribute the assets of the estate having regard only to the claims of which they then have notice.

Dated 6 September 1983

PRICE, HIGGINS & FIDGE, barristers and solicitors, 47 Yarra Street, Geelong, Victoria 3220. 8821

NORMAN GREVILLE SIMPSON, late of "Yooroobla" Jerilderie in New South Wales, grazier, deceased

Creditors, next of kin and others having claims in respect of the estate of the abovenamed deceased (who died on 11 September 1982) are required to send particulars of their claims to the executors Mary Osborne Simpson widow and George Andrew Norman Simpson grazier both of "Yooroobla" Jerilderie in New South Wales and Mary Kathleen Agnes Withers married woman of "Nanangroe" Coolac in New South Wales care of the undermentioned solicitors by 15 November 1983 after which date they may convey or distribute the assets having regard only to the claims of which they then have notice.

AITKEN WALKER & STRACHAN, solicitors, 114 William Street, Melbourne 3000. 8793

ARTURO PORTO, late of 174 Queen Street, Altona, contractor, deceased

Creditors, next of kin and others having claims in respect of the estate of the deceased, who died on 12 February 1983 are required by Lidia Porto, of 174 Queen Street, Altona, widow the executor to whom Probate of the Will of the said deceased was granted by the Supreme Court of Victoria to send particulars care of the undersigned by 21 November 1983 after which date the said Executor may convey or distribute the assets having regard only to the claims to which she then has notice.

PATRICK J. CANNON, TESTRO & COBURN, solicitors, 117 Durham Road, Sunshine. 8794

Creditors, next of kin and others having claims in respect of the Estate of Kathleen Annie Good, late of 63 Breed Street, Traralgon, widow, deceased, who died on 22 June 1983 and Probate of whose Will was granted by the Supreme Court of Victoria on 19 August 1983 to Joan Veronica Oates of 37A Moore Street, Traralgon, married woman, and Eileen Mary Downey, of 80 Henry Street, Traralgon, widow, are to send particulars of their claims to the said Executors care of the below mentioned Solicitors by 18 November 1983 after which date they will distribute the assets of the deceased having regard only to the claims of which they then have notice.

LITTLETON HACKFORD & MALKIN, solicitors, Law Chambers, 115-119 Hotham Street, Traralgon. 8797

JESSIE MARY STEELE, late of 27. Alexandra Street, East St Kilda, spinster, deceased

Creditors, next of kin and others having claims in respect of the estate of the deceased, who died on 4 May 1983, are required by Paul William Brochie, of 2 Sheringham Drive, Glen Waverley, solicitor, to send particulars to him care of the undermentioned Solicitors by 18 November 1983 after which date the Executor may convey or distribute the assets having regard only to the claims of which he then has notice.

HADEN SMITH & FITCHETT, solicitors, 423 Bourke Street, Melbourne. 8836

ANNE MARIE JOSEPHE METZ-GLISE (otherwise known as Anne Marie Josephe Glise), late of Trompstraat 7 Flat 5, Zandvoort in the Netherlands, married woman, deceased intestate

Creditors, next of kin and others having claims in respect of the estate of the deceased, who died on 24 April 1973, are required by the personal representatives, Mark Nicholas Cerche and Graeme Dean John Henshaw, both of 447 Collins Street, Melbourne, solicitors, to send particulars to them by 27 November 1983 after which date the personal representatives may convey or distribute the estate having regard only to the claims of which they then have notice.

ARTHUR ROBINSON & CO., solicitors, 447 Collins Street, Melbourne. 8837

KARLHEINZ EISENMENGER, late of Obersontheim-Untersontheim, West Germany, company director, deceased intestate

Creditors, next of kin and others having claims in respect of the estate of the deceased, who died on 26 September 1976, are required by the personal representatives, Mark Nicholas Cerche and Graeme Dean John Henshaw, both of 447 Collins Street, Melbourne, solicitors, to send particulars to them by 27 November 1983 after which date the personal representatives may convey or distribute the estate having regard only to the claims of which they then have notice.

ARTHUR ROBINSON & CO., solicitors, 447 Collins Street, Melbourne. 8838

CATHERINE MABEL AMY EASTHAM, late of 53 Charles Street, East Brighton, widow, deceased

Creditors, next of kin and others having claims in respect of the estate of the deceased, who died on 3 January 1983, are required by The Perpetual Executors and Trustees Association of Australia Limited, of 50 Queen Street, Melbourne, and James Charles Osborne Eastham, of 53 Charles Street, East Brighton, company representative, the Applicants for a grant of administration to send particulars of their claims to the said Applicants in the care of the said Company by 16 November 1983 after which date they will convey or distribute the assets having regard only to the claims of which they then have notice.

CLARKE RICHARDS GRANT & CO., 350 La Trobe Street, Melbourne, Victoria 3000. 8844

Creditors, next of kin or others having claims in respect of the estate of Muriel Ivy Badcock, formerly of Flat 1, Yallambee Village, Gwalia Street, Traralgon in the State of Victoria, but late of Traralgon District Nursing Home in the said State, pensioner, deceased, who died on 6 August 1983, are to send particulars of their claims to the executrix care of the undermentioned Solicitors by 12 November 1983 after which date the executrix will distribute the assets having regard only to the claims of which she then has notice.

D. C. DAVINE & ASSOCIATES, solicitors, 39 Breed Street, Traralgon. 8845

ALICE LOUISA JACKSON, formerly of 12 Bambury Street, Boronia, but late of 800 Mt. Dandenong Road, Montrose, spinster, deceased

Creditors, next of kin and others having claims in respect of the estate of the deceased, who died on 25 August 1983, are required by the Executors John Allan Brown of 9 Turana Street, Doncaster, divisional manager and Raymond Dawson of 18 Russell Street, Surrey Hills, retired, to send particulars to the undermentioned firm by 4 December 1983 after which date the said Executors may convey or distribute the assets having regard only to the claims of which notice has by then been given.

SETON WILLIAMS & SMYTH, solicitors, 408 Collins Street, Melbourne. 8799

BERYL MAY CROOKE, late of Unit 3, 3 Anzac Street, Murrumbena in the State of Victoria, spinster, deceased

Creditors, next of kin and others having claims in respect of the estate of the deceased, who died on 12 April 1983, are required by the personal representatives, Charles Leslie Morrow, of 4 Camp Crescent, Castlemaine in the said State, hospital orderly, and Leslie William Bell, of 337 Koornang Road, Carnegie in the said State, retired, to send particulars to them by 15 November 1983 after which date the personal representatives may convey or distribute the assets having regard only to the claims of which they then have notice.

WEIGALL & CROWTHER, of 459 Little Collins Street, Melbourne, solicitors for the estate. 8835

HARRY KURTZ, formerly of 285 Alma Road, Caulfield in the State of Victoria, manufacturer, but late of 619 St Kilda Road, St Kilda in the said State, retired manufacturer, deceased

Creditors, next of kin and others having claims in respect of the estate of the deceased, who died on 10 May 1982, are required by Solomon Kurtz, of 82 Lumeah Road, Caulfield in the said State, company director, and Emmanuel Herszkowicz, of 279 Domain Road, South Yarra in the said State, company director, the executors named in the Will of the said deceased, to send particulars of their claims to the said executors care of Oakley Thompson & Co., of 205 King Street, Melbourne, solicitors, by 24 November 1983 after which date the Executors may convey or distribute the assets having regard only to the claims of which they then have notice.

OAKLEY THOMSON & CO., solicitors, 205 King Street, Melbourne 3000. 8856

Creditors, next of kin and others having claims in respect of the estate of Muriel Christina King, late of "Strathlea" Glengarry, married woman, deceased, who died on 15 June 1983 and Probate of whose Will was granted by the Supreme Court of Victoria on 19 August 1983 to George Ian King of "Strathlea" Glengarry, farmer, Kay Christine Baxter of Fraser's Lane, Glengarry, married woman and Ian Douglas King, of "Strathlea" Glengarry, farmer, are to send particulars of their claims to the said Executors care of the below mentioned Solicitors by 18 November 1983 after which date they will distribute the assets of the deceased having regard only to the claims of which they then have notice.

LITTLETON HACKFORD & MALKIN, solicitors, Law Chambers, 115-119 Hotham Street, Traralgon. 8798

Creditors, next of kin and others having claims in respect of the estate of Jessie Margaret Bruce Montgomerie, late of 62 MacGregor Street, East Malvern, gentlewoman, deceased, who died on 3 June 1983, are required to send particulars of their claims to the Executor National Trustees Executors and Agency Company of Australasia Limited, of 95 Queen Street, Melbourne by 17 November 1983 after which date the executor will distribute the assets having regard only to the claims of which it then has notice.

8795

HAROLD THORNTON GRIMWADE, late of "Urara", Lismore, Victoria, grazier, deceased

Creditors, next of kin and others having claims in respect of the Estate of the deceased, who died on 1 December 1982, are required by the personal representatives, Constance Rosemary Crozier-Durham, of "Urara", Lismore, Deborah Rutherford Cunliffe, of "Yallambie", Pringles Road, Anakie, and John Stuart Cockburn Mercer, of "Elephant North", Derrinallum, to send particulars to them care of G. I. Stevenson & Co., 406 Collins Street, Melbourne by 18 November 1983 after which date the personal representatives may convey or distribute the assets of the Estate, having regard only to the claims of which they then have notice.

HEDDERWICK, FOOKES & ALSTON, 121 William Street, Melbourne. 8872

CHARLES LLOYD COGHLAN, late of 20 Docker Street, Wangaratta, medical practitioner, deceased

Creditors, next of kin and others having claims in respect of the estate of the deceased, who died on 25 March 1983, are requested to send particulars of their claims to the Executrix, Enid Sterckx Coghlan, care of the undersigned Solicitor by 15 November 1983 after which date the said Executrix will proceed to distribute the Estate having regard only to the claims of which she then has notice.

MARJORY C. COATES, solicitor, of 422 Collins Street, Melbourne 3000. 8834

Creditors, next of kin and others having claims in respect of the Will of Ileen Muriel Costigan, late of 18 Clive Street, East Brighton, widow, who died on 20 June 1983, are requested to send particulars of their claims to the Executors, Adrian Joseph Costigan and National Trustees Executors and Agency Company of Australasia Limited, care of National Trustees Executors and Agency Company of Australasia Limited, of 95 Queen Street, Melbourne by 23 November 1983 after which date they will distribute the assets having regard only as to the claims of which they then have notice.

EDWARD CURMI, 440 Victoria Street, North Melbourne. 8852

Creditors, next of kin or others having claims in respect of the estate of Michael Balzan, formerly of Senglea in Malta, then of Yalourn North in the State of Victoria, but late of 227 Sanctuary Street, Zabbar in Malta, unemployed, deceased, who died on 25 March 1982, are to send particulars of their claims to the administratrix care of the undermentioned Solicitors by 15 November 1983 after which date the administratrix will distribute the assets having regard only to the claims of which she then has notice.

D. C. DAVINE & ASSOCIATES, solicitors, 39 Breed Street, Traralgon. 8853

Creditors, next of kin and others having claims against the Estate of George Valentine Arnott, late of 54 Beresford Road, Lilydale, retired, deceased (who died on 9 June 1983) are required by Patrick Francis Toohey, the Executor of the Will of the said deceased, to send to him care of the undersigned Solicitors particulars thereof by 30 November 1983 after which date he will distribute the assets having regard only to the claims of which he shall then have notice.

GAVAN DUFFY & KING, solicitors, 95 Queen Street, Melbourne. 8854

In the Supreme Court of the State of Victoria
SALE BY THE SHERIFF

On 27 October 1983 at 2.30 p.m. at the Sheriff's Office, Writs and Warrants Division, 2nd Floor, 241 William Street, Melbourne (unless process be stayed or satisfied).

All the Estate and Interest (if any) of Pasquale Morlacci, of 44 Morris Street, Reservoir as proprietor of an estate in fee simple in the land described in Certificate of Title Volume 8472 Folio 950 upon which is erected a cream brick veneer house known as No. 44 Morris Street, Reservoir.

Registered Mortgage Nos. F488224 and H559502 and Caveat No. H891793 affect the said estate and interest.

Terms—Cash only

8876

L. ROUTREE, Sheriff's Officer

In the Supreme Court of the State of Victoria
SALE BY THE SHERIFF

On 27 October 1983 at 2.30 p.m. at the Sheriff's Office, Writs and Warrants Division, 2nd Floor, 241 William Street, Melbourne (unless process be stayed or satisfied).

All the Estate and Interest (if any) of Bartholomew Degen and Gail Robyn Degen, of 3 Gumtree Grove, Belgrave Heights as joint proprietors of an estate in fee simple in the land described in Certificate of Title Volume 8704 Folio 709 upon which is erected a dwelling house known as No. 3 Gumtree Grove, Belgrave Heights.

Registered Mortgage No. G884200 and Caveat No. J946046 affect the said estate and interest.

Terms—Cash only

8877

L. ROUNTREE, Sheriff's Officer

In the Supreme Court of the State of Victoria
SALE BY THE SHERIFF

On 27 October 1983 at 2.30 p.m. at the Sheriff's Office, Writs and Warrants Division, 2nd Floor, 241 William Street, Melbourne (unless process be stayed or satisfied).

All the Estate and Interest (if any) of Peter James Flynn, of 317 Mascoma Street, Strathmore as joint proprietor with Averil Elizabeth Flynn, of an estate in fee simple in the land described in Certificate of Title Volume 8559 Folio 269 upon which is erected a double storey brick veneer house known as No. 317 Mascoma Street, Strathmore.

Registered Mortgage No. J937 and Caveat Nos. K344784 and K430087 affect the said estate and interest.

Terms—Cash only

8878

J. GREEN, Deputy Sheriff

In the Supreme Court of the State of Victoria
SALE BY THE SHERIFF

On 27 October 1983 at 2.30 p.m. at the Sheriff's Office, Writs and Warrants Division, 2nd Floor, 241 William Street, Melbourne (unless process be stayed or satisfied).

All the Estate and Interest (if any) of David John Thomas, of 34 Beatrice Street, Cheltenham as sole proprietor of an estate in fee simple in the land described in Certificate of Title Volume 8742 Folio 311 upon which is erected a brick veneer house known as No. 34 Beatrice Street, Cheltenham.

Registered Mortgage Nos. F592238 and G412366 and Caveat No. K458272 affect the said estate and interest.

Terms—Cash only

8879

J. GREEN, Deputy Sheriff

In the Supreme Court of the State of Victoria
SALE BY THE SHERIFF

On 27 October 1983 at 2.30 p.m. at the Sheriff's Office, Writs and Warrants Division, 2nd Floor, 241 William Street, Melbourne (unless process be stayed or satisfied).

All the Estate and Interest (if any) of Peter Edward Favaloro, of corner of Long View Road and Pleasant Rise, South Croydon as joint proprietor with Eleanor Frances Favaloro of an estate in fee simple in the land described in Certificate of Title Volume 8657 Folio 411 upon which is erected a two storey brick house known as corner Longview Road and Pleasant Rise, South Croydon.

Registered Mortgage Nos. J695261 and J695262 affect the said estate and interest.

Terms—Cash only
 8880

J. GREEN, Deputy Sheriff

In the Supreme Court of the State of Victoria
SALE BY THE SHERIFF

On 27 October 1983 at 2.30 p.m. at the Sheriff's Office, Writs and Warrants Division, 2nd Floor, 241 William Street, Melbourne (unless process be stayed or satisfied).

All the Estate and Interest (if any) of Leondrew Holdings Pty. Ltd., of 8 Creighton Way, Yarrambat as proprietor of an estate in fee simple in the land described in Certificate of Title Volume 9134 Folio 773 upon which is erected a dwelling known as No. 8 Creighton Way, Yarrambat.

Registered Mortgage No. H836239 and the Covenant contained in Transfer G324613 affect the said estate and interest.

Terms—Cash only
 8873

L. ROUNTREE, Sheriff's Officer

In the Supreme Court of the State of Victoria
SALE BY THE SHERIFF

On 31 October 1983 at 2.30 p.m. at State Public Offices, corner Fenwick and Lt. Malop Streets, Geelong (unless process be stayed or satisfied).

All the Estate and Interest (if any) of Henricus Antonius Te Wierik (shown on Certificate of Title as Hendrikus Antonius Te Wierik), of 12 Adelaide Street, Highton.

Firstly: as proprietor of an estate in fee simple in the land described in Certificate of Title Volume 8789 Folio 089 upon which is erected a three bedroom brick veneer home known as No. 18 Fryers Road, Highton.

Registered Mortgage No. F82906 and Caveat No. K147513 affect the said estate and interest.

Secondly: as proprietor of an estate in fee simple in the land described in Certificate of Title Volume 8817 Folio 748 upon which is vacant land known as Nos. 27, 29, 31, 33 and 35 Tower Road, Portarlington.

Registered Mortgage No. F82907 and Caveat No. K147512 affect the said estate and interest.

Thirdly: as proprietor as tenants in common in equal shares with Franciscus Bernadus Te Wierik, Albertus Jozef Te Wierik, Wilhelmus Te Wierik and Fredericus Wilhelmus Te Wierik of an estate in fee simple in the land described in Certificates of Title Volume 8845 Foliros 641, 642 and 643 which is vacant land known as Nos. 237, 239 and 241 Mount Pleasant Road, Highton.

Registered Caveat Nos. K147509, K147510 and K147511 affect the said estate and interest.

Terms—Cash only
 8874

L. ROUNTREE, Sheriff's Officer

In the Supreme Court of the State of Victoria
SALE BY THE SHERIFF

On 27 October 1983 at 2.30 p.m. at the Sheriff's Office, Writs and Warrants Division, 2nd Floor, 241 William Street, Melbourne (unless process be stayed or satisfied).

All the Estate and Interest (if any) of C. W. Murphy (shown on Certificate of Title as William Murphy), of 12 Alma Place, St Kilda as joint proprietor with Lorraine Dorothy Kay, of an estate in fee simple in the land described in Certificate of Title Volume 8492 Folio 648 upon which is erected a brick house known as No. 12 Alma Place, St Kilda.

Registered Mortgage Nos. H91421 and J542284 affect the said estate and interest.

Terms—Cash only
 8875

L. ROUNTREE, Sheriff's Officer

**NOTICE OF MAKING OF
 STATUTORY RULES
 WHICH ARE NOT YET
 AVAILABLE**

Notice is given of the making of the following Statutory Rules:

- No. *Chiropodists Act 1968*
 213/1983. *Chiropodists (Registration Fees) Regulations 1983*
Racing Act 1958
 214/1983. *Racing (Mixed Sports Gatherings) (No. 3) Regulations 1983*

**NOTICE OF MAKING AND
 AVAILABILITY OF
 STATUTORY RULE**

In pursuance of the provisions of the *Subordinate Legislation Act 1962* and the Regulations made thereunder notice is given of the making and availability of the following Statutory Rules:

- | | | |
|-------------|--|-------|
| No. | <i>Environment Protection Act 1970</i> | Price |
| 208/1983. | <i>Environment Protection (Motor Car Noise) (Amendment) Regulations 1983</i> | 20c |
| | <i>Motor Boating Act 1961</i> | |
| 210/1983. | <i>Motor Boating (Lake Narracan) Regulations 1983</i> | 20c |
| | <i>Land Act 1958</i> | |
| 211/1983. | <i>Land Act (Fees) Regulations 1983</i> | 20c |
| | <i>Mt. Hotham Alpine Resort Act 1972</i> | |
| 212/1983. | <i>Mt. Hotham Alpine Resort (Fees) Regulations 1983</i> | 20c |
| | <i>Public Service Act 1974</i> | Price |
| PSD61/1983. | <i>Public Service Amendment Determinations (No. 61) 1983</i> | 20c |

Copies of these Statutory Rules are available and may be purchased at the Victorian Government Bookshop, located at 41 St. Andrews Place, East Melbourne (formerly 7A Parliament Place, Melbourne, 3002). If ordered by mail, remittance should be addressed to "The Government Printer, Box 203, North Melbourne, 3051", and should include 50c delivery and handling fee.

The annual subscription rates for Statutory Rules for the year commencing 1 January 1982, payable in advance are as follows:

*Statutory Rules (other than Public Service Determinations), Pamphlet copies only	\$55.00
Public Service Determinations	\$33.00

* The Bound Volume of Statutory Rules is not included in the subscription rate.

F. D. ATKINSON
Government Printer

STATE ACTS, 1983

Copies of the following Acts of the Parliament of Victoria may be obtained at the Victorian Government Bookshop, 41 St. Andrews Place, East Melbourne, phone 651 2754 or 651 2759, or from any accredited agent, at the price set opposite to each.

A delivery and handling fee must be added to your remittance when ordering by mail as follows:

Total Value of Acts Ordered	Delivery and Handling Fee
10c-\$2.00	0.60c
\$2.05-\$5.00	\$1.00
\$5.05-\$25.00	\$1.50
\$25.05-\$75.00	\$2.00
Above \$75.00	\$3.00

Bound Volumes of 1979 State Acts (\$22.00) and the Index to the Bound Volumes (\$10.00) are also available.

The annual subscription rate for State Acts for the year commencing 1 January 1982 is \$50.

No.	Price
9864. Minerals and Energy Fees	\$0.60
9865. Administrative Law (Amendment)	\$0.20
9866. Local Government (Investments)	\$0.40
9867. Motor Accidents (Amendment)	\$0.40
9868. Motor Car (Learner Drivers)	\$0.80
9869. The Constitution Act Amendment (Temporary Provisions)	\$0.20
9870. Constitution (Local Government)	\$0.40
9871. Local Government (Municipal Council Elections)	\$1.00
9872. Chiropodists (Amendment)	\$0.20
9873. Liquor Control (Amendment)	\$0.20
9874. Land Settlement (Amendment)	\$0.20
9875. Juries (Amendment)	\$0.20
9876. Health (Consultative Council)	\$0.20
9877. Companies (Administration) (Amendment)	\$0.20
9878. Scout Association	\$1.20
9879. Community Welfare Services (Amendment)	\$1.00
9880. Lotteries Gaming and Betting (Administration)	\$0.20
9881. Prisoners (Interstate Transfer)	\$1.00
9882. Decentralized Industry Incentive Payments (Amendment)	\$0.40
9883. Film Victoria (Amendment)	\$0.20
9884. Limitation of Actions (Personal Injury Claims)	\$0.40
9885. Business Franchise Acts (Amendment)	\$0.40
9886. Motor Boating (Amendment)	\$0.20
9887. Public Authorities (Contributions) (Amendment)	\$0.20
9888. Hospital Benefits (Levy) (Amendment)	\$0.20
9889. Health (Radiation Safety)	\$0.80
9890. Historic Buildings (Amendment)	\$0.80
9891. Railways (Amendment)	\$0.20
9892. Constitution (Electoral Provinces and Districts)	\$0.20
9893. Management and Budget	\$0.20
9894. Electoral Commission (Amendment)	\$0.20
9895. Water and Sewerage Authorities (Restructuring)	\$2.00
9896. Geelong Waterworks and Sewerage (Bellarine Water Supply)	\$0.40

STATE ACTS, 1983—continued

No.	Price
9897. Road Traffic (Amendment)	\$0.20
9898. ANZ Executors and Trustee Company	\$0.40
9899. Industrial Relations (Amendment)	\$0.20
9900. Supply (1983-84, No. 1)	\$0.40
9901. Works and Services (Supply 1983-84)	\$1.00
9902. Statute Law Revision	\$1.20
9903. Museums	\$1.20
9904. Grain Elevators (Amendment)	\$0.20
9905. Motor Accidents (Applications)	\$0.20
9906. Police Regulation (Amendment)	\$0.20
9907. Mental Health (Amendment)	\$0.20
9908. Historic Buildings (Further Amendment)	\$0.20
9909. Consumer Affairs Committee	\$0.20
9910. Town and Country Planning (Amendment)	\$0.40
9911. Stamps (Amendment)	\$0.60
9912. Legal Profession Practice (Solicitors' Guarantee Fund)	\$0.20
9913. Community Welfare Services (Attendance Centre Permits)	\$0.20
9914. St. Andrew's Hospital (Guarantee) (Amendment)	\$0.20
9915. Supporting Parents Concession	\$0.20
9916. Administrative Arrangements	\$0.40
9917. Public Account (Advances)	\$0.20
9918. Medical Practitioners (Amendment)	\$0.40
9919. Beer Prices Regulation (Temporary Provisions)	\$0.20
9920. Rural Finance and Settlement Commission (Penalties)	\$0.20
9921. Transport	\$5.20
9922. Revocation and Excision of Crown Reservation	\$0.60
9923. Nuclear Activities (Prohibitions)	\$0.40
9924. Racing (Amendment)	\$0.80
9925. Estate Agents (Reconstitution)	\$0.20
9926. Pipelines (Amendment)	\$0.40
9927. State Insurance Office (Extension of Franchise)	\$0.40
9928. Fire Authorities	\$0.40
9929. State Board of Education	\$0.60
9930. Barley Marketing (Amendment)	\$0.20
9931. Liquor Control	\$0.80
9932. Firearms (Amendment)	\$1.00
9933. Post-Secondary Education (Amendment)	\$1.60
9934. Hospitals and Charities (Committees of Management)	\$0.60
9935. Construction Industry Long Service Leave	\$2.00
9936. Mines (Amendment)	\$4.40

THE "VICTORIA GOVERNMENT GAZETTE"

PUBLICATION—A VICTORIA GOVERNMENT GAZETTE is published every WEDNESDAY EVENING unless advertised otherwise.

SUBSCRIPTIONS—The annual subscription rate, including postage, is \$80, payable in advance.

PRIVATE ADVERTISEMENTS—Advertisements will be received by the Government Printer not later than the day preceding publication—at ordinary rates at or before ONE p.m. and at double rates between ONE p.m. and HALF PAST THREE p.m. The charge for ADVERTISEMENTS is \$3.20 per single column centimetre or part centimetre and \$6.40 per double column centimetre or part centimetre. The charge for a full page is \$150. On an average, there are thirty words in each single column centimetre. Signatures (in particular) and proper names must be written very clearly in the text: ONE SIDE ONLY of each sheet of paper should be written upon.

All documents NOT CLEARLY PREPARED will be returned unpublished. Where brands occur, not provided for by the ordinary letters of the alphabet, a written explanatory description also must be furnished.

PAYMENTS—Unless the advertiser has a Credit Account, all payments are required in advance. Remittances should be made by cheque, postal order or money order, payable to "GOVERNMENT PRINTER".

CORRESPONDENCE—All correspondence should be addressed to "The Victorian Government Printer, P.O. Box 203, North Melbourne, 3051".

CONTENTS

	Page
Acts of Parliament	2962
Appointments	2949
Auction Sales Act	2970
Bank Holidays	2960
Contracts	2945, 2964
Estates of Deceased Persons	2948
Government Notices	2940
Lands	2959
Late Notices	2960
Melbourne and Metropolitan Board of Works— Notice	2947
Minerals and Energy	2968
Notice to Mariners	2962
Notice of Making of Statutory Rules	2984
Orders in Council—	
Acts—Geelong Waterworks and Sewerage; Local Government; Crown Land (Reserves); Housing; Mildura Irriga- tion and Water Trusts; Water; Hospi- tals and Charities; Victorian Institute of Marine Sciences; Urban Renewal; Post-Secondary Education (Amend- ment); Education; Water	2951 et seq
Private Advertisements	2970
Public Holidays	2961
Resignations	2951
State Rivers and Water Supply Commission	2940
Tenders	2960
Transport Regulation Board—Public Hearings	2949, 2963