



Victoria Government Gazette

No. 43—Wednesday, 1 May 1985

PROCLAMATIONS

Water Act 1958

FIXING OF PERCENTAGE RATES OF INTEREST AND REDEMPTION IN URBAN DISTRICTS

PROCLAMATION

By His Excellency the Governor of the State of Victoria and its Dependencies in the Commonwealth of Australia, &c., &c., &c.

In pursuance of the powers conferred by section 81 of the *Water Act 1958*, I, the Governor of the State of Victoria in the Commonwealth of Australia, by and with the advice of the Executive Council of the said State, do hereby proclaim that in relation to the cost of works charged to the Urban Districts of the Rural Water Commission—

- (i) for the purposes of section 81, the proportion of interest and redemption taken into account to ascertain rates and charges for the year ending 30 June 1985, shall be:
 - (a) in respect of redemption, one quarter of one percent per annum of the cost of works charged to the Urban Districts;
 - (b) in respect of interest, eight percent per annum of the balance outstanding of the cost of works charged to the Urban Districts after deducting the amount of accumulated redemption paid.
- (ii) the matters referred to in this proclamation shall commence on 1 July 1984.

Given under my Hand and the Seal of the State of Victoria aforesaid, at Melbourne, this twenty-third day of April in the year of our Lord One thousand nine hundred and eighty-five and in the thirty-fourth year of the reign of Her Majesty Queen Elizabeth the Second, Queen of Australia.

(L.S.)

B. S. MURRAY

By His Excellency's Command

A. McCUTCHEON
Minister for Water Resources

GOD SAVE THE QUEEN!

Water Act 1958

FIXING OF PERCENTAGE RATES OF INTEREST AND REDEMPTION IN IRRIGATION, WATERWORKS, RURAL AND FLOOD PROTECTION DISTRICTS

PROCLAMATION

By His Excellency the Governor of the State of Victoria and its Dependencies in the Commonwealth of Australia, &c., &c., &c.

In pursuance of the powers conferred by section 81 of the *Water Act 1958*, I the Governor of the State of Victoria in the Commonwealth of Australia, by and with the advice of the Executive Council of the said State, do hereby proclaim that in relation to the cost of works charged to the Irrigation Waterworks, Rural and Flood Protection Districts of the Rural Water Commission—

- (i) for the purposes of section 81, the proportion of interest and redemption taken into account to ascertain rates and charges for the year ending 30 June 1985, shall be:
 - (a) in respect of redemption, one quarter of one percent per annum of the cost of works charged to the Irrigation, Waterworks, Rural and Flood Protection Districts;
 - (b) in respect of interest, three percent per annum of the balance outstanding of the cost of works charged to the Irrigation, Waterworks, Rural and Flood Protection Districts after deducting the amount of accumulated redemption paid.
- (ii) the matters referred to in this proclamation shall commence on 1 July 1984.

Given under my Hand and the Seal of the State of Victoria aforesaid, at Melbourne, this twenty-third day of April in the year of our Lord One thousand nine hundred and eighty-five and in the thirty-fourth year of the reign of Her Majesty Queen Elizabeth the Second, Queen of Australia.

(L.S.)

B. S. MURRAY

By His Excellency's Command

A. McCUTCHEON
Minister for Water Resources

GOD SAVE THE QUEEN!

**PUBLIC HIGHWAY—SHIRE OF
YACKANDANDAH**

PROCLAMATION

By His Excellency the Governor of the State of Victoria and its Dependencies in the Commonwealth of Australia, &c., &c., &c.

Whereas by the *Local Government Act* 1958, section 519 it is amongst other things enacted that it shall be lawful for the Governor in Council at any time and from time to time upon the request of the council of any municipality by notice in the *Government Gazette* to proclaim any land reserved used or by purchase or exchange acquired for a street road highway thoroughfare bridge square court alley or right-of-way or any street road lane or passage made or laid out or proposed to be made or laid out on any land of which a plan of subdivision delineating that street road lane or passage has been sealed with the seal of the municipality under subdivision (3) of Division 9 of Part XIX of the *Local Government Act* 1958 or a corresponding previous enactment to be a public highway and that such land shall thereupon and thenceforth from the date of such proclamation become and be absolutely dedicated to the public as a public highway within the meaning of any law then or thereafter in force.

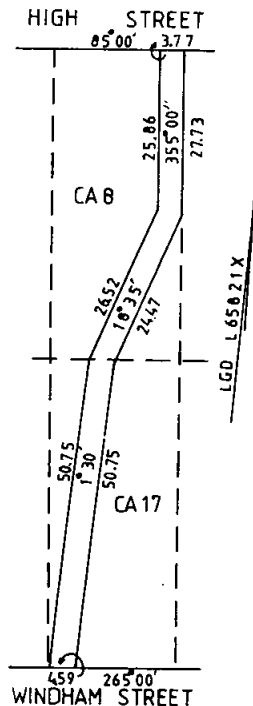

And whereas the Council of the Shire of Yackandandah has requested that the land hereinafter mentioned, reserved and used for a road, be so declared to be a public highway.

Now therefore, I, the Governor of the State of Victoria in the Commonwealth of Australia, by and with the advice of the Executive Council of the said State, do by this proclamation declare that Schlenkers Lane, Yackandandah as shown on the plan hereunder, shall be a public highway within the meaning of the said Act.

Given under my Hand and the Seal of the State of Victoria aforesaid, at Melbourne, this twenty-third day of April in the year of our Lord One thousand nine hundred and eighty-five and in the thirty-fourth year of the reign of Her Majesty Queen Elizabeth the Second, Queen of Australia.

(L.S.) B. S. MURRAY

By His Excellency's Command

J. L. SIMMONDS
Minister for Local Government

GOD SAVE THE QUEEN!

PUBLIC HIGHWAY—SHIRE OF DIMBOOLA

PROCLAMATION

By His Excellency the Governor of the State of Victoria and its Dependencies in the Commonwealth of Australia, &c., &c., &c.

Whereas by the *Local Government Act* 1958, section 519 it is amongst other things enacted that it shall be lawful for the Governor in Council at any time and from time to time upon the request of the council of any municipality by notice in the *Government Gazette* to proclaim any land reserved used or by purchase or exchange acquired for a street road highway thoroughfare bridge square court alley or right-of-way or any street road lane or passage made or laid out or proposed to be made or laid out on any land of which a plan of subdivision delineating that street road lane or passage has been sealed with the seal of the municipality under subdivision (3) of Division 9 of Part XIX of the *Local Government Act* 1958 or a corresponding previous enactment to be a public highway and that such land shall thereupon and thenceforth from the date of such proclamation become and be absolutely dedicated to the public as a public highway within the meaning of any law then or thereafter in force.

And whereas the Council of the Shire of Dimboola has requested that the land hereinafter mentioned, reserved and used for a road, be so declared to be a public highway.

Now therefore, I, the Governor of the State of Victoria in the Commonwealth of Australia, by and with the advice of the Executive Council of the said State, do by this proclamation declare that the land shown by hatching on the plan hereunder, shall be a public highway within the meaning of the said Act.

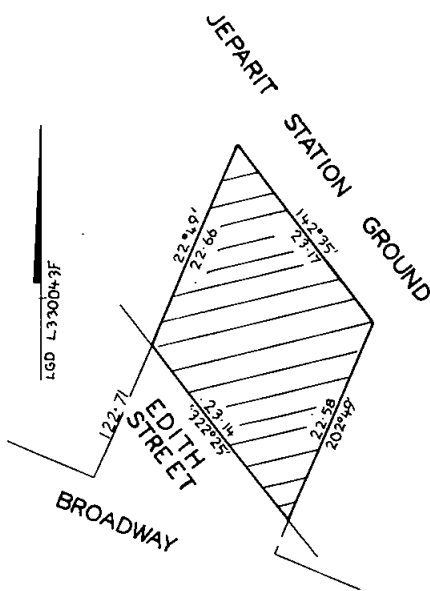

Given under my Hand and the Seal of the State of Victoria aforesaid, at Melbourne, this twenty-fourth day of April in the year of our Lord One thousand nine hundred and eighty-five and in the thirty-fourth year of the reign of Her Majesty Queen Elizabeth the Second, Queen of Australia.

(L.S.) B. S. MURRAY
By His Excellency's Command S. M. CRABB
Minister for Employment and Industrial Affairs
GOD SAVE THE QUEEN!

ACT OF PARLIAMENT

PROCLAMATION

By His Excellency the Governor of the State of Victoria and its Dependencies in the Commonwealth of Australia, &c., &c., &c.

I, the Governor of the State of Victoria, in the Commonwealth of Australia, do hereby declare that I have this day assented, in Her Majesty's name, to the Bill passed by the Parliament of the said State, the title whereof is hereunder set forth together with the short title, that is to say:

No. 10172. "An Act to amend section 82 of the *Labour and Industry Act 1958. (Labour and Industry (Anzac Day)) Act 1985.*

Given under my Hand and the Seal of the State of Victoria aforesaid, at Melbourne, this twenty-fourth day of April in the year of our Lord One thousand nine hundred and eighty-five and in the thirty-fourth year of the reign of Her Majesty Queen Elizabeth the Second, Queen of Australia.

(L.S.) B. S. MURRAY
By His Excellency's Command JOHN CAIN
Premier
GOD SAVE THE QUEEN!

No. 10172. This Act shall come into operation on the day on which it receives the Royal Assent.

Given under my Hand and the Seal of the State of Victoria aforesaid, at Melbourne, this twenty-third day of April in the year of our Lord One thousand nine hundred and eighty-five and in the thirty-fourth year of the reign of Her Majesty Queen Elizabeth the Second, Queen of Australia.

(L.S.) B. S. MURRAY
By His Excellency's Command J. L. SIMMONDS
Minister for Local Government
GOD SAVE THE QUEEN!

Bank Holidays Act 1958
BANK HOLIDAYS

PROCLAMATION

By His Excellency the Governor of the State of Victoria and its Dependencies in the Commonwealth of Australia, &c., &c., &c.

In pursuance of the powers conferred by the *Bank Holidays Act 1958*, I, the Governor of the State of Victoria, in the Commonwealth of Australia, do by this my Proclamation appoint the day and date mentioned hereunder to be observed as a Bank Half-Holiday at the places respectively specified:

Bank Half-Holiday from the hour of eleven a.m.
Thursday, 2 May 1985 within the City of Warrambool
Thursday, 2 May 1985 throughout the Borough of Port Fairy

PUBLIC HIGHWAY—SHIRE OF COLAC

PROCLAMATION

By His Excellency the Governor of the State of Victoria and its Dependencies in the Commonwealth of Australia, &c., &c., &c.

Whereas by the *Local Government Act 1958*, section 519 it is amongst other things enacted that it shall be lawful for the Governor in Council at any time and from time to time upon the request of the council of any municipality by notice in the *Government Gazette* to proclaim any land reserved used or by purchase or exchange acquired for a street road highway thoroughfare bridge square court alley or right-of-way

or any street road lane or passage made or laid out or proposed to be made or laid out on any land of which a plan of subdivision delineating that street road lane or passage has been sealed with the seal of the municipality under subdivision (3) of Division 9 of Part XIX of the *Local Government Act 1958* or a corresponding previous enactment to be a public highway and that such land shall thereupon and thenceforth from the date of such proclamation become and be absolutely dedicated to the public as a public highway within the meaning of any law then or thereafter in force.

And whereas the Council of the Shire of Colac has requested that the land hereinafter mentioned, being a street road lane or passage made or laid out or proposed to be made or laid out on land of which a plan of subdivision delineating such street road lane or passage has been sealed with the seal of the municipality under subdivision (3) of Division 9 of Part XIX of the *Local Government Act 1958*, or a corresponding previous enactment be so declared to be a public highway.

Now therefore, I, the Governor of the State of Victoria in the Commonwealth of Australia, by and with the advice of the Executive Council of the said State, do by this proclamation declare that that road coloured brown on Plans of Subdivision 125751, 125752, shall be a public highway within the meaning of the said Act.

Given under my Hand and the Seal of the State of Victoria aforesaid, at Melbourne, this twenty-third day of April in the year of our Lord One thousand nine hundred and eighty-five and in the thirty-fourth year of the reign of Her Majesty Queen Elizabeth the Second, Queen of Australia.

(L.S.) B. S. MURRAY

By His Excellency's Command

J. L. SIMMONDS
Minister for Local Government

GOD SAVE THE QUEEN!

GOVERNMENT NOTICES

TAFE TEACHING SERVICE

Election for members of the TAFE Teaching Service Discipline Appeals Board.

An election for members at the Teacher classification level to the TAFE Teaching Service Discipline Appeals Board has been conducted, the closing date being 4.00 p.m. on Friday 19 April 1985. As a result of this election, I declare the following members of the TAFE Teaching Service duly elected.

John Francis Hanley (Yallourn College of TAFE).

Pamela Dorothy Caven (Swinburne College of TAFE).

RON DEDMAN, Returning Officer

Transport Act 1983 ROAD TRAFFIC AUTHORITY

Commercial Passenger and Goods Vehicle Applications

Notice is hereby given that the following applications will be considered by the Road Traffic Authority on 21 May 1985.

Notice of any objections should be forwarded to reach the Manager, Vehicle Licensing Branch not later than 15 May 1985.

It will not be necessary for interested parties to appear on the hearing date specified, unless advised in writing by the Authority.

Notification of the date for consideration of applications which are objected to and which require determination by the Road Transport Licensing Tribunal will be published by further notice in this Gazette.

Benders Busways Pty. Ltd., Geelong North. Application for variation of UO and UC licence conditions to operate an additional tour as follows: *Tour*: Geelong to Airey's Inlet via Highton, Deakin University, Waurn Ponds, Anglesea to Airey's Inlet and return via Torquay. Tour includes meal at Airey's Inlet Hotel. *Timetable*: Depart Geelong 11.00 a.m. Return Geelong 5.30 p.m. *Fares*: \$24.00 per person (meal included).

Croydon Bus Service (Belgrave) Pty. Ltd., Croydon. Application for variation of the conditions of licences MC 114, MC 115, MC 147, MC 187 and MC 666 which authorizes day tours under permit commencing at Lilydale, Mooroolbark, Croydon and/or Ringwood Railway Stations or similar accessible points in the local area, to: (a) Operate additional tours to the following places: (i) Cumberland Valley. (ii) Melbourne Zoo. (iii) Darum Musical Village. (iv) Mt Dandenong Rhododendron Gardens/Silvan Tulip Farm. (v) French Island. (vi) Sandhurst Town/Bendigo. (vii) Wilsons Promontory. (viii) Hepburn Springs. (ix) Puffing Billy/Emerald Lake. (b) Vary existing tours as follows: (i) Tour to Mornington Peninsula—to include Sorrento Beach. (ii) Tour to Queenscliff and Bellarine Peninsula—to include Geelong. *Fares*: To be determined.

H. F. & M. M. George, Kilmore. Application for variation of the conditions of licence CT 21, which authorizes taxi operations from Kilmore, to increase the pick-up radius from 8 km to 15 km radius of the Post Office at Kilmore. *Note*: This application replaces a previous application by H. F. & M. M. George, published in the *Victoria Government Gazette*, No. 10 of 6 february 1985.

Hilton Hotels of Australia (Melbourne) Pty. Ltd., East Melbourne. Application to license one commercial passenger vehicle with seating capacity for 11 persons, to operate a courtesy bus service for guests of the Hilton Hotel, free of charge, on a round route departing the Hotel in Wellington Parade via Wellington Parade, Flinders Street, Exhibition Street, Collins Street, Elizabeth Street, Lonsdale Street, Albert Street, Clarendon Street and Wellington Parade to the Hotel. *Timetable*: (Monday to Friday) Depart Hotel a.m. 8.20,

8.45, 9.10, 10.00, 10.45, 11.30 p.m. 12.15, 2.50, 3.30, 4.15, 4.55, 5.25, 5.50. *Note:* This application replaces a previous application which appeared in the *Victoria Government Gazette*, No. 17 of 13 March 1985.

K. Holloway, Dandenong. Application to license a class 1 tow truck to operate throughout the State of Victoria from a depot located at 10 Kirkham Road, Dandenong for the purpose of lifting and carrying or towing damaged or disabled motor vehicles. *Note:* The purpose of this application is to change the operational address of tow truck licence No. 771 from 63 Bennett Street, Dandenong to 10 Kirkham Road, Dandenong.

Lakeside Caravan Park Pty. Ltd., Bonnie Doon. Application to license two commercial passenger vehicles, one with seating capacity for 18 persons and one with seating capacity for 22 persons to operate as follows: (i) For the carriage of guests or residents accommodated at Lakeside Caravan Park, Bonnie Doon to areas and places of interest in the north eastern area of Victoria, within a 90 km radius of Boonie Doon. (ii) For the carriage of guests of the Lakeside Caravan Park between the Melbourne metropolitan area and the caravan park. *Note:* Passengers to be carried will be pre-booked at the caravan park under a package deal arrangement which will include accommodation, transport and meals. *Fares:* To be determined.

Lonsdale Nominees Pty. Ltd., Caulfield. Application for one Special Purpose Vehicle licence in respect of a 1975 Rolls Royce sedan with seating capacity for 5 persons to operate from 32 Queens Avenue, Caulfield for the carriage of entertainers and business-men using the security service provided by Lonsdale Nominees Pty. Ltd.

R. Micallef and T. Drewitz, Melton West. Application to license one commercial passenger vehicle with seating capacity for 18 persons to operate under charter conditions from within a 20 km pick-up radius of Melton.

G. D. Sandlant, Landsborough. Application to license one commercial passenger vehicle with seating capacity for 45 or 49 persons, to be purchased, to operate under charter conditions from within a 20 km pick-up radius of Ararat Post Office.

G. Scott, Warrandyte. Application for two Special Purpose Vehicle licences in respect of 1963-1966 Leyland "London Taxi" sedans each with seating capacity for 6 persons to operate from 24 Drysdale Road, Warrandyte for the carriage of passengers for wedding parties and special tours.

1 May 1985

C. J. V. SMITH

Chief General Manager, Registration and Regulation

Transport Act 1983

ROAD TRAFFIC AUTHORITY

Commercial Passenger Vehicle Applications

Notice is hereby given that applications by the following parties, previously gazetted and objected to, will be considered by the Road Transport Licensing Tribunal, as follows:

(i) Commencing at 10.30 a.m. on Thursday 16 May 1985 in the City of Shepparton, Council Chambers, 90 Welsford Street, Shepparton.

<i>Applicant</i>	<i>Previous Gazette No.</i>	<i>Date</i>
C. W. & G. A. Baker	123	31.10.84
L. G., H. T. & R. G. Cardwell	119	24.10.84

(ii) Commencing at 2.30 p.m. on Tuesday, 21 May 1985 in the City of Sale, Mayor's Chamber, Macalister Street, Sale.

<i>Applicant</i>	<i>Previous Gazette No.</i>	<i>Date</i>
G. M. Noble	119	24.10.84

(iii) Commencing at 9.30 a.m. on Wednesday, 22 May 1985 in the Shire of Bairnsdale, Council Chambers, McCulloch Street, Bairnsdale.

<i>Applicant</i>	<i>Previous Gazette No.</i>	<i>Date</i>
A. J. Henderson	4	23.1.85
G. C. Richardson	4	23.1.85

1 May 1985

C. J. V. SMITH

Chief General Manager, Registration and Regulation

Town and Country Planning Act 1961

MELBOURNE METROPOLITAN PLANNING SCHEME

Amendment No. 344

Notice of Amendment

In pursuance of the powers conferred by the *Town and Country Planning Act 1961*, the Governor in Council on 23 April 1985, amended the abovementioned scheme in respect of the municipal district of the City of St. Kilda and for which the Melbourne and Metropolitan Board of Works is the Responsible Authority.

The amendment comes into operation on the date this Notice is published in the *Government Gazette*.

The amendment amends Clause 24 (21) (a) of the planning scheme ordinance to allow the responsible authority to permit a proposed dwelling at 29-33 Bath Street, St. Kilda.

A copy of the documents may be inspected free of charge, during office hours, at the office of the Ministry for Planning and Environment (Plan Inspection Section), 5th Floor, 235 Queen Street, Melbourne, and at the office of the Melbourne and Metropolitan Board of Works, 625 Little Collins Street, Melbourne.

DAVID YENCKEN

Secretary for Planning and Environment

Town and Country Planning Act 1961

SHIRE OF ROMSEY INTERIM DEVELOPMENT ORDER 1977

Amendment No. 9

Notice of Amendment

In pursuance of the powers conferred by the *Town and Country Planning Act 1961*, the Governor in Council on 23 April 1985, amended the abovementioned order in respect of Lot 2, Lodged Plan

86217, Melbourne—Lancefield Road, Romsey and for which the Romsey Shire Council is the Responsible Authority.

The amendment comes into operation on the date this Notice is published in the *Government Gazette*.

The amendment includes the rezoning of the above land from 'Public Purposes Council Owned Land' to General Urban.

A copy of the documents may be inspected free of charge, during office hours, at the office of the Ministry for Planning and Environment (Plan Inspection Section), 5th Floor, 235 Queen Street, Melbourne, and at the office of the Council of the Shire of Romsey at Romsey.

DAVID YENCKEN
Secretary for Planning and Environment

Town and Country Planning Act 1961
SHIRE OF ROMSEY INTERIM DEVELOPMENT
ORDER 1977

Amendment No. 10
Notice of Amendment

In pursuance of the powers conferred by the *Town and Country Planning Act 1961*, the Governor in Council on 23 April 1985, amended the abovementioned Order in respect of part Crown Allotment 13, Hamilton Road, Parish of Kerrie, Shire of Romsey and for which the Romsey Shire Council is the Responsible Authority.

The amendment comes into operation on the date this Notice is published in the *Government Gazette*.

The amendment includes the rezoning of the above land from Light Industrial to General Farming Zone.

A copy of the documents may be inspected free of charge, during office hours, at the office of the Ministry for Planning and Environment (Plan Inspection Section), 5th Floor, 235 Queen Street, Melbourne, and at the office of the Council of the Shire of Romsey.

DAVID YENCKEN
Secretary for Planning and Environment

Town and Country Planning Act 1961
CITY OF MELBOURNE (CENTRAL CITY)
INTERIM DEVELOPMENT ORDER 1982

Amendment No. 28
Notice of Amendment

In pursuance of the powers conferred by the *Town and Country Planning Act 1961*, the Governor in Council on 23 April 1985, amended the abovementioned order in respect of land situated at and known as 430 to 436 Little Collins Street, Melbourne and for which the Ministry for Planning and Environment is the Responsible Authority.

The amendment comes into operation on the date this Notice is published in the *Government Gazette*.

The amendment includes details of a redevelopment proposal for the land for the purposes of residential accommodation and ancillary purposes.

A copy of the documents may be inspected free of charge, during office hours, at the office of the Ministry for Planning and Environment (Plan Inspection Section), 5th Floor, 235 Queen Street, Melbourne.

DAVID YENCKEN
Secretary for Planning and Environment

Town and Country Planning Act 1961
MELBOURNE METROPOLITAN PLANNING
SCHEME

Amendment No. 278, Part 4
Notice of Approval

In pursuance of the powers conferred by the *Town and Country Planning Act 1961*, the Governor in Council on 30 April 1985, approved the abovementioned scheme for which the Melbourne and Metropolitan Board of Works is the Responsible Authority.

The scheme comes into operation on the date this Notice is published in the *Government Gazette*.

The scheme proposes (i) the rezoning of land on the Nepean Highway, Cheltenham to Restricted Business to allow the establishment of a community market; and (ii) to extend Urban Conservation controls over selected areas in the Cities of Fitzroy and St. Kilda.

A copy of the documents may be inspected free of charge, during office hours, at the office of the Ministry for Planning and Environment (Plan Inspection Section), 5th Floor, 235 Queen Street, Melbourne and at the office of the Melbourne and Metropolitan Board of Works, 625 Little Collins Street, Melbourne.

DAVID YENCKEN
Secretary for Planning and Environment

Office of Minerals and Energy
INTENTION TO RENEW A MINING LEASE

No. 490-1; A. R. Freeman, Executor for Estate of Robert W. Bennett and Wendy J. Bennett, trading as Northern Gypsum; 140.2 ha, Parish of Wewin.

MINING LEASE EXPIRED

No. 680; Noel T. Burns, Robert Burns and Paul J. Burns; 12.4 ha, Parish of Weston.

APPLICATION FOR MINING LEASE
WITHDRAWN

No. 1195; Seaham Exploration Pty. Ltd.; 141 ha, Parishes of Painswick and Dunolly.

APPLICATION FOR MINING AREA LICENCE
WITHDRAWN

No. 1; Western Mining Corporation Limited; 36.6 ha, Parish of Stawell.

APPLICATIONS FOR WATERLINE LICENCES
WITHDRAWN

No. 2; Western Mining Corporation Limited; 2000 metres, Parish of Stawell.

No. 3; Western Mining Corporation Limited; 1400 metres, Parish of Stawell.

APPLICATIONS FOR TAILINGS TREATMENT LICENCES WITHDRAWN

- No. 238; K. R. Dunlop; to treat tailings situated approximately 8 km south of Carisbrook in the Parish of Craigie.
- No. 250; Coemo Kirsten Pty. Ltd.; to treat tailings situated in the north west corner of Havelock/Betley Road and Bet Bet Road, Betley in the Parish of Bet Bet.

APPLICATIONS FOR TAILINGS REMOVAL LICENCES REFUSED

- No. 5011; Wesley R. Pearce; to remove tailings from the "Prince of Wales Dump"—Williams Road, Eaglehawk in the Parish of Nerring.
- No. 5012; Bendigo Gold Associates Pty. Ltd.; to remove tailings from the "Virginia and Specimen Hill Dumps"—Eaglehawk in the Parish of Nerring, for treatment elsewhere.
- No. 5017; Bendigo Gold Associates Pty. Ltd.; to remove tailings from the "Iron Bark Battery Tailings" in Hayes Street, Bendigo, in the Parish of Sandhurst.
- No. 5018; Bendigo Gold Associates Pty. Ltd.; to remove tailings from Specimen Hill, Bendigo, in the Parish of Sandhurst.

TAILINGS REMOVAL LICENCES GRANTED

- No. 4967; Shire of Strathfieldsaye; to remove tailings situated on SEC Easement off Shelton's Road in the Parish of Mandurang.
- No. 4976; Sambas Gold Mining Pty. Ltd.; to remove tailings from the Shamrock Creek, north west of Harrierville below Old Rose Thistle Shamrock Battery in the Parish of Harrierville.
- No. 4993; Shire of Avoca; to remove tailings from the Gravel Reserves in the Parish of Rathscar.
- No. 5003; Sambas Gold Mining Pty. Ltd.; to remove tailings from the Growlers Creek west branch above and below the Myrtle Battery site in the Parishes of Bright and Freeburgh.
- No. 5009; Sambas Gold Mining Pty. Ltd.; to remove tailings from the Growlers Creek, Wandiligong west branch below the Phoenix Battery site in the Parish of Freeburgh.
- No. 5014; Shire of Wangaratta; to remove tailings from the Reedy Creek, Eldorado township, in the Parish of Byawatha.

EXPLORATION LICENCE EXPIRED

- No. 813; CRA Exploration Pty. Ltd.; 508 km², Counties of Bourke and Grant.
- The above area will become available again for Exploration Licence on 1 October 1985.

EXPLORATION LICENCE TRANSFERRED

- No. 1191; From 3 D's Gold Mine NL to Bendigo Mining NL.

APPLICATION FOR EXPLORATION LICENCE WITHDRAWN

- No. 1387; George R. Taylor, Denis R. Brown and Brian W. Cuffley; 66 km², County of Bogong.

APPLICATION FOR EXPLORATION LICENCE DECLARED ABANDONED

- No. 1411; Resource Technology Pty. Ltd.; 83.5 km², Counties of Delatite and Bogong.

INTENTION TO GRANT AN EXPLORATION LICENCE

- No. 1454; Samedan Oil Corporation; 389.5 km², County of Croajingolong.

EXPLORATION LICENCES GRANTED

- No. 1497; Ben Yeoman Pty. Ltd.; area retained 26 km², area refused nil, County of Wonnangatta.
- No. 1509; Western Mining Corporation Limited; area retained 49.25 km² area refused 2.75 km², County of Bendigo.

EXTRACTIVE INDUSTRY LICENCE GRANTED

- No. 1172; Granite Rock Quarries; 3.39 ha, Parish of Sarsfield.

EXTRACTIVE INDUSTRY SEARCH PERMIT EXPIRED

- No. 115; Leonard Thompson trading as Sun Haulage and Contracting; 5 km², Parish of Woodend.

ROBERT FORDHAM
Minister for Industry, Technology and Resources

CONTRACTS ACCEPTED—(Series 1984/85)

PUBLIC WORKS

Ballaarat City—Construction of external R. & P. Parklands Clinic. Ballarat Lakeside Mental Hospital—\$98 800.00—T. & B. Radosavljevic, Gladstone Park.

Bannockburn Shire—Civil Works. Bannockburn Primary School—\$51 000.00—P. Krnjaic, Bell Post Hill.

Benalla City—Internal and external renovations. Benalla Public Offices—\$84 329.00—Southwell Constructions, Wangaratta.

Box Hill City—External repairs and painting. Box Hill North Primary School—\$58 325.00—C. & L. Krstev, Bundoora.

Box Hill City—Cyclic maintenance. Koonung High School—\$78 000.00—R. & M. B. Fredriksson Pty. Ltd., Doncaster East.

Box Hill City—Cyclic maintenance. Koonung Heights Primary School—\$83 300.00—C. & L. Krstev, Bundoora.

Brunswick City—External repairs. Brunswick West Primary School—\$52 127.00—B. & D. Eastern Contractors, Kilsyth.

Bulla Shire—Electrical upgrade. Sunbury Caloola Training Centre—\$83 200.00—R. H. Bernhardt Pty. Ltd., Richmond.

Bulla Shire—Construction of new police station. Sunbury Police Station—\$2 087 189.00—Lewis Construction Co. Pty. Ltd., Melbourne.

Buln Buln Shire—Construction of new police station. Neerim South Police Station—\$88 900.00—C. & N. Marshall, Neerim South.

Croydon City—Building extensions. Croydon Police Station—\$104 310.00—Florentin Construction Co., Surrey Hills.

Dunmunkle Shire—Construction of one man station and residence. Minyip Police Station—\$198 891.00—Onley's Holdings Pty. Ltd., Donald.

Essendon City—Upgrade of fire service—Stage Two. Buckley Park High School—\$80 351.00—Cooke and Dowssett Pty. Ltd., Tullamarine.

Footscray City—Construction of new toilet block. Footscray Primary School—\$120 569.00—Cappellin and Co. Pty. Ltd., Brunswick East.

Kew City—Lint collection units—laundry. Kew Willsmere Psychiatric Hospital—\$73 178.00—A. & V. Hart Pty. Ltd., Greenborough.

Knox City—Staff administration upgrade. The Basin Primary School—\$101 230.00—D. P. and B. Cullen, Montrose South.

Lilydale Shire—Extension to police station. Lilydale Primary School—\$59 546.00—Floline Decorative Finishes Pty. Ltd., Kilsyth.

Melbourne City—Alterations to building. Debney Park High School—\$55 888.00—R. & S. Developments Pty. Ltd., Riddells Creek.

Melbourne City—Internal and external repairs and painting. Melbourne William Angliss College—\$119 400.00—J. & D. Mazzetti, Balwyn North.

Melbourne City—Repairs to core. Melbourne State Offices—1 Treasury Place—\$232 710.00—John R. & E. Seccull Pty. Ltd., Moorabbin.

Melton Shire—Cyclic maintenance. Melton Primary School—\$59 113.00—Pilgrim Painting and Renovations, Footscray.

Mildura Shire—Construction of new toilet block. Irymple Primary School—\$56 329.00—J. T. King and L. S. Hudswell, Mildura.

Mirboo Shire—Internal and external renovations and painting. Mirboo North Primary School—\$127 700.00—G. K. Marinkovic, Yarraville.

Moorabbin City—Staff administration, classroom upgrade, science room upgrade. Moorabbin City Technical High School—\$1 289 859.00—P. M. Versteegen and Sons Pty. Ltd., Ringwood.

Mordialloc City—Library administration upgrade. Mentone Girls High School—\$521 160.00—E. & R. Roberts Pty. Ltd., Dandenong North.

Nunawading City—Staff administration upgrade. Laburnum Primary School—\$89 950.00—D. P. and B. Cullen, Montrose South.

Northcote City—Hydraulic services. Fairlea Women's Prison—\$64 986.00—Cappellin and Co. Pty. Ltd., Brunswick East.

Oakleigh City—Internal maintenance. Huntingdale Primary School—\$58 081.00—Floline Decorative Finishes Pty. Ltd., Kilsyth.

Portland Town—Cyclic maintenance. Portland High School—\$310 000.00—G. K. Marinkovic, Yarraville.

Pakenham Shire—Staff administration upgrade. Cockatoo Primary School—\$455 682.00—R. J. Grills Pty. Ltd., Surrey Hills.

Sherbrooke Shire—Construction of new oval and hardcourts. Emerald Post Primary School—\$212 474.00—P. M. Versteegen and Sons Pty. Ltd., Ringwood.

South Melbourne—Partitioning. Melbourne 412 St. Kilda Road (Police)—\$256 110.25—P. M. Versteegen and Sons Pty. Ltd., Ringwood.

South Barwon City—Upgrade and internal cyclic maintenance. Oberon Primary School—\$494 674.00—E. J. Lyons and Sons Pty. Ltd., Geelong South.

Swan Hill Shire—Internal and external repairs and renovations. Robinvale Police Station—\$78 028.00—D. M. and P. M. Carmichael, Swan Hill.

Tambo Shire—Building works. Lakes Entrance Post Primary School—\$1 443 252.49—Lucknow Plant Hire Pty. Ltd., Bairnsdale.

Various—Supply and delivery of relocatable buildings. Various sites—\$316 864.00—R. M. and J. C. Hunter, Bendigo.

Various—Supply and delivery of relocatable buildings. Various sites—\$519 776.00—Modkon Construction Pty. Ltd., Ballarat.

Various—Supply and delivery of relocatable buildings. Various sites—\$723 110.00—L. & J. McNamara, Bendigo.

Various—Supply and delivery of relocatable buildings. Various sites—\$1 187 781.00—Cemac Associated Ltd., Reservoir.

Various—Supply and delivery of relocatable buildings. Various sites—\$2 247 180.00—Ebir by Zarock, Brunswick.

Wangaratta City—Internal and external renovations. Wangaratta West Primary School—\$99 850.00—Roy O. Tobias, Wangaratta.

Wangaratta Shire—Construction of new school. Wangaratta South Primary School—\$232 652.00—F. & D. Jensen Constructions, Beechworth.

Warrnambool Shire—New steam boilers, building and mechanical services. Warrnambool Brierly Mental Hospital—\$652 815.00—J. C. Taylor and Sons. (Aust.) Pty. Ltd., South Melbourne.

Winchelsea Shire—Replacement of roof. Lorne Erskine House—\$50 310.00—Corio Bay Plumbing, North Geelong.

Werribee Shire—Construction of new building. Werribee Water Training Centre (Water)—\$445 887.00—John Belani Pty. Ltd., Carlton.

Dated 23 April 1985

D. J. LITTLE
Director General of Public Works

STATE TENDER BOARD
CONTRACTS ACCEPTED
Amendments

Schedule Number	Item Number	New Rate	Effective Date
		\$	
Steel (Mild)			
1/35	2	*	
* Delete: Elders Metals Ltd. Add: Steelmark—A Division of the ANI Corporation Ltd.			

Schedule Number	Item Number	New Rate	Effective Date
		\$	
<i>Hand Tools (General)</i>			
1/56	74	1.66	18.3.85
	75	2.23	
	94	3.70	
	95	4.00	
	271	2.49†	1.3.85
† Substitution: Delete: "AOK" Add: "Pressol"			
<i>Motor Vehicles</i>			
1/58J	3	12 078.00	3.4.85
Delivery Charge: 74.20			
<i>General Stationery and School Requisites</i>			
1/64	34	2.76	10.4.85
<i>Dictation Equipment</i>			
1/73	2(a)	125.57	2.4.85
	3(a)	218.35	
	(b)Footswitch	24.67	
	Headset	14.46	
<i>Provisions—Melbourne and Metropolitan District</i>			
2/01	27	29.63*	1.3.85
	52	3.65	
	66	10.87	
	103	24.70	
	104	23.25	
	105	23.25	
	108	23.25	
	109	17.17	
	110	25.51	
	111	16.33	
	112	24.80	
	113	16.33	
	114	24.80	
	116	27.03	
* Delete: "Gold Crest" Add: "AFS"			
<i>Provisions—Butter</i>			
2/03			*
* Delete: La Trobe Valley Wholesalers Pty. Ltd. Add: Campbells Cash and Carry Pty. Ltd.			
<i>Provisions—Cheese</i>			
2/04			*
* Delete: La Trobe Valley Wholesalers Pty. Ltd. Add: Campbells Cash and Carry Pty. Ltd.			
<i>Provisions—Morwell River Reforestation Prison</i>			
2/18(4)			*
* Delete: La Trobe Valley Wholesalers Pty. Ltd. Add: Campbells Cash and Carry Pty. Ltd.			
<i>Provisions—Sale Gaol</i>			
2/20(4)			*

* Delete: La Trobe Valley Wholesalers Pty. Ltd.
Add: Campbells Cash and Carry Pty. Ltd.

Provisions—Traralgon, Hobson Park Hospital
2/24(4) *

* Delete: La Trobe Valley Wholesalers Pty. Ltd.
Add: Campbells Cash and Carry Pty. Ltd.

Provisions—Won Wron Reforestation Prison
2/27(4) *

* Delete: La Trobe Valley Wholesalers Pty. Ltd.
Add: Campbells Cash and Carry Pty. Ltd.

Meat—Ballarat District
3/07(2) 147 *

Victoria Government Gazette, No. 35 dated 17 April 1985.

*Delete: Item No. 147

J. M. PAWSON
Secretary to the Tender Board

Police Offences Act 1958, No. 6337

DIVISION 1A—STATE CLASSIFICATION OF PUBLICATIONS BOARD

Take note that the State Classification of Publications Board has classified the following publications in accordance with the provisions of section 180H (1) of the *Police Offences Act 1958*.

Each publication shall be subject to the following restrictions:

- It shall not be offered for sale, sold or delivered to any person under the age of 18 years;
- It shall not be made available for inspection or perusal by any person under the age of 18 years;
- It shall not be exhibited or displayed in any place to which persons under the age of 18 years have access or so that it is visible from any such place;
- It shall not be advertised in any manner whatsoever.

<i>Title</i>	<i>Distributor</i>
Latent Image—Vol. 6, No. 5	Venus Enterprises Pty. Ltd.

R. V. DOOLEY
Acting Secretary
State Classification of Publications Board

Police Offences Act 1958, No. 6337

DIVISION 1A—STATE CLASSIFICATION OF PUBLICATIONS BOARD

Take note that the State Classification of Publications Board has classified the following publications in accordance with the provisions of section 180H (1) of the *Police Offences Act 1958*.

Each publication shall be subject to the following restrictions:

- It shall not be offered for sale, sold or delivered to any person under the age of 18 years;
- It shall not be made available for inspection or perusal by any person under the age of 18 years;

<i>Title</i>	<i>Distributor</i>	
Best of Club International, The—No. 8	Gordon and Gotch Ltd.	(a) It shall not be offered for sale, sold or delivered to any person under the age of 18 years;
Best of "Genesis"—Letters—Summer 1985	Gordon and Gotch Ltd.	(b) It shall not be made available for inspection or perusal by any person under the age of 18 years;
Buf—May 1985	Gordon and Gotch Ltd.	(c) It shall not be exhibited or displayed in any place to which persons under the age of 18 years have access or so that it is visible from any such place.
Club International—Vol. 14 No. 5	Gordon and Gotch Ltd.	
Erotic X—Film Guide—June 1985	Gordon and Gotch Ltd.	<i>Title</i>
Escort—Vol. 5, No. 4	Gordon and Gotch Ltd.	<i>Distributor</i>
Gallery—June 1985	Gordon and Gotch Ltd.	Cavalier—March 1985
Gung-Ho—April 1985	Gordon and Gotch Ltd.	Chic—April 1985
Hustler Humor—March 1985	Gordon and Gotch Ltd.	Cinema Blue—February 1985
Iron Horse—June 1985	Gordon and Gotch Ltd.	Cinema Blue—May 1985
Knave—Vol. 17, No. 4	Gordon and Gotch Ltd.	Harvey—March 1985
Mandate—May 1985	Gordon and Gotch Ltd.	Hustler—April 1985
Max—March 1985	Gordon and Gotch Ltd.	Hustler—June 1985
Mr Male Review—Vol. 1, No. 6—May 1985	Gordon and Gotch Ltd.	Juggs—February 1985
Numbers—April 1985	Gordon and Gotch Ltd.	Leg Show—March 1985
Sexlaugh Cartoons	Gordon and Gotch Ltd.	Live! April 1985
Soldier of Fortune—March 1985	Gordon and Gotch Ltd.	Live! May 1985
Soldier of Fortune—May 1985	Gordon and Gotch Ltd.	Oui—Baseball '85 Special—Vol. 4, No. 55
Survive—May 1985	Gordon and Gotch Ltd.	Oui—May 1985
Swank—June 1985	Gordon and Gotch Ltd.	Playguy—February 1985
Torso—February 1985 (Valentine Special Issue)	Gordon and Gotch Ltd.	Stag—June 1985
Couples Today—June 1985	Gordon and Gotch Ltd.	Very Best of High Society, The—No. 2 (Special Collector's Edition)
Penthouse Variations—May 1985	Gordon and Gotch Ltd.	Video—X—February 1985
Turn-on Letters—Vol. 4, No. 22	Gordon and Gotch Ltd.	Best of Turn-Ons—No. 5
Chubby Cheeks	Venus Enterprises Pty. Ltd.	Family Affairs—May 1985
Gang Babes—No. 4	Venus Enterprises Pty. Ltd.	Family Letters—March 1985
Prime—No. 4	Venus Enterprises Pty. Ltd.	First Hand—April 1985
		Special Edition—No. 13
		Hustler Fantasies—April 1985
		Letters—March 1985
		Manscape—May 1985
		Options—Vol. 4, No. 20
		Turn-Ons—June 1985
		Turn-On Letters—Vol. 4, No. 23
		Cock Hungry Pussy—Premiere Issue
		Cock Lovers
		Crazy For Cock
		Cum Suckers
		Double Fucking
		Foxy Fucking Females
		Fuck Festival
		Horny Chicks
		Lez Be Friends

Police Offences Act 1958, No. 6337

DIVISION 1A—STATE CLASSIFICATION OF PUBLICATIONS BOARD

Take note that the State Classification of Publications Board has classified the following publications in accordance with the provisions of section 180H (1) of the *Police Offences Act 1958*.

Each publication shall be subject to the following restrictions:

Love-In—No. 1	Venus Enterprises Pty. Ltd.	Titty Fruity—2/3	Venus Enterprises Pty. Ltd.
Love-In—No. 2	Venus Enterprises Pty. Ltd.	Tongue In Pussy—No. 1	Venus Enterprises Pty. Ltd.
Love-In—No. 3	Venus Enterprises Pty. Ltd.		R. V. DOOLEY Acting Secretary
Love-In—No. 4	Venus Enterprises Pty. Ltd.		State Classification of Publications Board
Porno Special	Venus Enterprises Pty. Ltd.		
Anal Thrust—The Insatiables—No. 13	Venus Enterprises Pty. Ltd.		
Black Pharaohs	Venus Enterprises Pty. Ltd.		
Brotherly Fuck	Venus Enterprises Pty. Ltd.		
Built To The Hilt	Venus Enterprises Pty. Ltd.		
Cocksure—No. 1	Venus Enterprises Pty. Ltd.		
Con Job	Venus Enterprises Pty. Ltd.		
Cum-Sucking Vixens	Venus Enterprises Pty. Ltd.		
Diamond Special—No. 1 (Gourmet Edition—No. 47)	Venus Enterprises Pty. Ltd.		
Dirty Blondes	Venus Enterprises Pty. Ltd.		
Double Fucked Special (Gourmet Special—No. 32)	Venus Enterprises Pty. Ltd.		
Doomed Courier, The And An Undertaker's Treasure	Venus Enterprises Pty. Ltd.		
Fourgy	Venus Enterprises Pty. Ltd.		
For Members Only	Venus Enterprises Pty. Ltd.		
Horny Hole—No. 1	Venus Enterprises Pty. Ltd.		
Hot Fucking She—Males	Venus Enterprises Pty. Ltd.		
Hot Lez No. 1	Venus Enterprises Pty. Ltd.		
Inside Curve	Venus Enterprises Pty. Ltd.		
Juicy Lucy—No. 1	Venus Enterprises Pty. Ltd.		
Lesbian Cocksuckers—No. 1	Venus Enterprises Pty. Ltd.		
Licken Lezzies—No. 1	Venus Enterprises Pty. Ltd.		
Rubber Suckers	Venus Enterprises Pty. Ltd.		
Seducers, The	Venus Enterprises Pty. Ltd.		
'69' Fuckers—No. 1	Venus Enterprises Pty. Ltd.		
Sorority Suck—No. 1	Venus Enterprises Pty. Ltd.		
Spread 'Em	Venus Enterprises Pty. Ltd.		
Tender Ass—No. 1	Venus Enterprises Pty. Ltd.		

The Constitution Act Amendment Act 1958

REGISTRATION OF POLITICAL PARTIES

Notice is hereby given that the political parties listed hereunder have been registered as political parties in accordance with the provision of Division 1A of Part V. of *The Constitution Act Amendment Act 1958*—

Name of registered political party:

Australian Democrats (Victoria Division)

Abbreviation of name of party (optional)

Democrats

Name and address of registered officer

L. S. Bates, 22 Kalmaine Court, Diamond Creek, Vic., 3089.

Name of registered political party:

Australian Labor Party—Victorian Branch.

Abbreviation of name of party (optional)

Australian Labor Party

Name and address of registered officer

P. Batchelor, 23 Drummond Street, Carlton South, Vic., 3053.

Name of registered political party:

Call to Australia

Abbreviation of name of party (optional)

C.T.A.

Name and address of registered officer

V. E. Renkema, 5 Lansell Close, North Ringwood, Vic., 3134.

Name of registered political party:

Democratic Labor Party (DLP) of Australia

Abbreviation of name of party (optional)

Democratic Labor Party (DLP)

Name and address of registered officer

J. V. Mulholland, 82 Huxley Avenue, Mulgrave, Vic., 3170.

Name of registered political party:

Liberal Party of Australia—Victoria Division

Abbreviation of name of party (optional)

Liberal

Name and address of registered officer

J. S. Ridley, 104 Exhibition Street, Melbourne, Vic., 3000.

Name of registered political party:

National Party of Australia—Victoria

Abbreviation of name of party (optional)

National Party

Name and address of registered officer

J. W. Cuming, 24 Collins Street, Melbourne, Vic., 3000.

Name of registered political party:

Nuclear Disarmament Party (Victorian Branch)

Abbreviation of name of party (optional)

Nuclear Disarmament Party

Name and address of registered officer

S. C. Melzer, 4 Grace Street, Camberwell, Vic., 3124.

Name of registered political party:

Weekend Trading Party

Abbreviation of name of party (optional)

Weekend Trading Party

Name and address of registered officer

F. W. Penhalluriack, 345 Hawthorn Road, South Caulfield, Vic., 3162.

E. L. RICHARDSON
Chief Electoral OfficerPROPOSED REVOCATION OF TEMPORARY
RESERVATION OF LAND BY ORDER IN
COUNCIL

In pursuance of the provisions of section 10 of the *Crown Land (Reserves) Act 1978*, notice is hereby given that it is the intention of the Governor in Council to revoke the temporary reservation of land by order in Council hereunder referred to, viz:

Evansford—The temporary reservation by Order in Council of 26 November 1866 of 8094 square metres of land in the Township of Evansford (adjoining allotment 79) for Common School purposes—(E106(2) (Rs.6081)).

Evansford—The temporary reservation by Order in Council of 11 August 1873 of 2681 square metres of land in the Township of Evansford for State School—(E106(2) (Rs.6081)).

Doutta Galla (Ascot Vale)—The temporary reservation by Order in Council of 21 August 1979 of 1060 square metres, more or less, of land in the Parish of Doutta Galla, being Crown allotment 10A, section 4, for Social Welfare purposes—(D85(6) (Rs.10652)).

J. E. KIRNER
Minister for Conservation, Forests and Lands

REGULATIONS

Public Purposes Reserve, Parish of Narree Worrان

I, Joan Elizabeth Kirner, Her Majesty's Minister for Conservation, Forests and Lands in and for the State of Victoria in pursuance of the powers conferred on me by section 13 of the *Crown Land (Reserves) Act 1978* do hereby substitute the following Regulation for Regulation No. 2 made on 27 March 1984 (vide *Government Gazette* dated 4 April 1984) for or with respect to the above mentioned Reserve:

Regulation No. 2 of the said Regulations shall now read:

2. Any member of the public shall be permitted to enter upon and play golf on any specified portion of the Reserve on the following terms and conditions and on payment of the fees as shown:

(a) For every 18 holes on the 18 hole course on Saturdays, Sundays, and Public Holidays—\$6.00.

(b) For every 9 holes on the 18 hole course on Saturdays, Sundays, and Public Holidays—\$3.60.

(c) For every 18 holes on the 18 hole course on weekdays except Public Holidays—\$5.00.

(d) For every 9 holes on the 18 hole course on weekdays except Public Holidays—\$3.00.

(e) For every 9 holes on the 9 hole course on Saturdays, Sundays, and Public Holidays—\$1.90.

(f) For every 9 holes on the 9 hole course on weekdays except Public Holidays—\$1.60; Pensioners \$1.15.

(g) For every student playing on weekdays—one half of the fees applicable to the course played.

(h) The first and tenth tees of the 18 hole course shall not be available for play to members of the public between the following hours—

(i) 7.00 a.m. and 1.00 p.m. on Saturdays.

(ii) 9.30 a.m. and 1.00 p.m. on Sundays and Public Holidays.

(iii) 9.00 a.m. and 12 noon on Wednesdays between the months of February and November both inclusive—(Rs.8820).

Given under my hand at Melbourne on 26 April 1985

JOAN E. KIRNER
Minister for Conservation, Forests and Lands

REGULATION

Bushland Reserve—Parish of Scoresby

I, Joan Elizabeth Kirner, Her Majesty's Minister for Conservation, Forests and Lands in and for the State of Victoria, in pursuance of the powers conferred on me by section 13 of the *Crown Land (Reserves) Act 1978* do hereby apply the Regulations made on 5 September 1984 (vide *Government Gazette* dated 12 September 1984) for or with respect to the land in the Parish of Gembrook permanently reserved for the Conservation of an Area of Natural Interest, to the land in the Parish of Scoresby deemed to be temporarily reserved for the Conservation of an Area of Natural Interest or Beauty or of Historical or Scientific Interest as shown on Department of Conservation, Forests and Lands correspondence No. Rs12926.

26 April 1985

JOAN E. KIRNER
Minister for Conservation, Forests and Lands

REGULATIONS

Maribyrnong Valley Metropolitan Park

I, Joan Elizabeth Kirner, Her Majesty's Minister for Conservation, Forests and Lands in and for the State of Victoria, in pursuance of the powers conferred on me by section 13 of the *Crown Land (Reserves) Act 1978* do hereby apply the Regulations made on 3 May 1978 for or with respect to the land in the Parish of Bulleen permanently reserved for a Public Park by Order in Council of 18 March 1982 (vide *Government Gazette* dated 24 March 1982) to the lands in the Parish

of Maribyrnong temporarily reserved for a Public Park by Orders in Council of 6 February 1979, 27 March 1984 and 30 October 1984 (vide *Government Gazettes* dated 14 February 1979, 4 April 1984 and 7 November 1984 respectively).

26 April 1985

JOAN E. KIRNER

Minister for Conservation, Forests and Lands

REGULATIONS

“Penguin Reserve”—Parish of Phillip Island

I, Joan Elizabeth Kirner, Her Majesty's Minister for Conservation, Forests and Lands in and for the State of Victoria, in pursuance of the powers conferred on me by section 13 of the *Crown Land (Reserves) Act 1978* do hereby apply the Regulations made on 8 March 1983 (vide *Government Gazette* dated 16 March 1983) for or with respect to the above mentioned Reserve, to the land in the Parish of Phillip Island temporarily reserved for the Conservation of Wildlife and Public Recreation by Order in Council of 5 March 1985 (vide *Government Gazette* dated 13 March 1985)—(Rs.7419).

26 April 1985

JOAN E. KIRNER

Minister for Conservation, Forests and Lands

REGULATIONS

“Caulfield Park” Reserve

I, Joan Elizabeth Kirner, Her Majesty's Minister for Conservation, Forests and Lands in and for the State of Victoria, in pursuance of the powers conferred on me by section 13 of the *Crown Land (Reserves) Act 1978* do hereby rescind the Regulations made on 11 August 1975 for or with respect to the land in Parish of Prahran permanently reserved for Public Park, Gardens and Public Recreation by Order in Council of 23 August 1966 (vide *Government Gazette* dated 31 August 1966) in so far only as they relate to the portion of the Reserve vested in the Corporation of the City of Caulfield pursuant to section 16 of the *Crown Land (Reserves) Act 1978* being Crown Allotment 32A.

26 April 1985

JOAN E. KIRNER

Minister for Conservation, Forests and Lands

Cemeteries Act 1958

SCALE OF FEES OF THE PANMURE PUBLIC CEMETERY

In pursuance of the powers conferred upon them by the Cemeteries Act the trustees of the Panmure Public Cemetery hereby make the following scale of fees, which shall come into operation upon publication in the *Government Gazette*, and from and after such publication every scale of fees heretofore made by the said trustees shall be and is hereby rescinded to the extent to which it conflicts with this scale.

Public Graves

Interment in Grave without exclusive right—Stillborn Child	\$ 30.00
--	----------

Interment in Grave without exclusive right—Others	50.00
Number Peg or Label	15.00

Private Graves

Land, 2.44m × 1.22m	75.00
Own selection of land (extra)	55.00

Sinking Charges for Private Graves

Sinking grave 1.83m deep	110.00
Each additional 0.3m	25.00
Sinking oversize grave	40.00
Cancellation of order to sink (if commenced)	25.00
Reopening grave (no cover)	110.00
Reopening grave (with cover)	120.00

Miscellaneous Charges

Interment fee	35.00
Interment outside prescribed hours, or on Saturdays, Sundays or Public Holidays or without due notice	45.00
Certificate of Right of Burial	10.00
Number Plate or Brick	15.00
Permission to erect a headstone or monument—5% of cost with a minimum of \$15.00	
Exhuming the remains of a body (when authorized)	300.00
Interment of ashes in a private grave	35.00

C. MOONEY, Trustee

W. BOURKE, Trustee

H. HASTINGS, Trustee

Approved by the Governor in Council, 23 April 1985—L. G. HOUSTON, Clerk of the Executive Council

Cemeteries Act 1958

SCALE OF FEES OF THE EMERALD PUBLIC CEMETERY

In pursuance of the powers conferred upon them by the Cemeteries Act the trustees of the Emerald Public Cemetery hereby make the following scale of fees, which shall come into operation upon publication in the *Government Gazette*, and from and after such publication every scale of fees heretofore made by the said trustees shall be and is hereby rescinded to the extent to which it conflicts with this scale.

	\$
Land, 2.44m × 1.22m	80.00
Sinking grave 2.13m deep	100.00
Sinking grave 2.13m deep for casket	110.00
Re-opening grave	70.00
Monumental fee	10.00

D. BEVAN, Trustee

K. HOGAN, Trustee

A. LATTE, Trustee

G. RYBERG, Trustee

Approved by the Governor in Council, 23 April 1985—L. G. HOUSTON, Clerk of the Executive Council

Cemeteries Act 1958

SCALE OF FEES OF THE ROBINVALE PUBLIC CEMETERY

In pursuance of the powers conferred upon them by the Cemeteries Act the trustees of the Robinvale Public Cemetery hereby make the following scale of fees, which shall come into operation upon publication in the *Government Gazette*, and from and after such publication every scale of fees heretofore made by the said trustees shall be and is hereby rescinded to the extent to which it conflicts with this scale.

Public Graves

	\$
Interment in grave without exclusive right—stillborn child	35.00
Interment in grave without exclusive right—others	70.00
Number peg or label	7.00

Private Graves

Land, 2.44m × 1.22m	65.00
Own selection of site (extra)	30.00

Sinking Charges for Private Graves

Sinking grave 1.8m deep	70.00
Each additional 0.3m deep	20.00
Sinking oversize grave (extra)	40.00
Cancellation of order to sink (if commenced)	25.00
Reopening grave (no cover)	85.00
Reopening grave (with cover or kerb)	100.00

Miscellaneous Charges

Interment fee	30.00
Interment not in the prescribed hours or on Saturdays, Sundays or Public Holidays or without due notice	46.00
Late fee where less than eight hours (working hours) notice is given	30.00
Certificate of Right of Burial	6.00
Number plate or brick	12.00
Annual maintenance (single grave) if required by holder of Right of Burial (optional)	35.00
Permission to erect a monument up to \$5000.00	80.00
Permission to erect a monument over \$5000.00	230.00
Permission to construct or to erect any stone kerb, brick tilework or concrete	25.00
Grave renovations or additional inscription	12.00
Exhuming the remains of a body (when authorized)	230.00
Interment of ashes in a private grave	35.00

T. R. NEEMAN, Trustee
L. K. HARROP, Trustee
L. ENGLEFIELD, Trustee

Approved by the Governor in Council, 23 April 1985—L. G. HOUSTON, Clerk of the Executive Council

Cemeteries Act 1958

SCALE OF FEES OF THE BROADFORD PUBLIC CEMETERY

In pursuance of the powers conferred upon them by the Cemeteries Act the trustees of the Broadford Public Cemetery hereby make the following scale of fees, which shall come into operation upon publication in the *Government Gazette*, and from and after such publication every scale of fees heretofore made by the said trustees shall be and is hereby rescinded to the extent to which it conflicts with this scale.

Lawn Section

Land 2.44m × 1.22m including first interment, Bronze Plaque 381mm × 279mm, as supplied by the Trust, with inscription, and interment and digging.	500.00
Re-open grave	130.00
Reservation of lawn grave site (not including plaque or interment fee)	330.00

Monumental Section

Land 2.44m × 1.22m	50.00
Sinking of grave	130.00
Re open of grave	130.00
Re open of grave with a cover	150.00

Miscellaneous

Interment fee	25.00
Interment of Ashes in a private grave	25.00
Interment on Weekends or Public Holiday—extra	30.00
Sinking oversize grave—extra	30.00
Permission to erect a headstone or monument—5% of cost with minimum of \$ 15.00	
Permission to construct brick grave or erect any form of kerb, tile work or concrete—5% of cost with minimum of \$15.00	

A. R. McDOUGALL, Trustee
S. WILLS, Trustee
H. L. BALMER, Trustee

Approved by the Governor in Council, 23 April 1985—L. G. HOUSTON, Clerk of the Executive Council

Cemeteries Act 1958

SCALES OF FEES OF THE CRANBOURNE PUBLIC CEMETERY

In pursuance of the powers conferred upon them by the Cemeteries Act the trustees of the Cranbourne Public Cemetery hereby make the following scale of fees, which shall come into operation upon publication in the *Government Gazette*, and from and after such publication every scale of fees heretofore made by the said trustees shall be and is hereby rescinded to the extent to which it conflicts with this scale.

Public Graves

	\$
Interment in grave without exclusive right—stillborn child	35.00

Interment in grave without exclusive right— others	65.00	Land for private grave 2.44m × 1.22m	\$ 60.00
		Sinking grave 1.83m deep	100.00
		Sinking grave 2.13m deep	120.00
		Reopening grave	65.00
		Interment fee	20.00
		Reopening fee	20.00
		Permission to erect a headstone or monument—5% of cost	
			N. M. ERWIN, Trustee E. L. LADSON, Trustee J. S. STEVENS, Trustee

Approved by the Governor in Council, 23 April 1985—L. G. HOUSTON, Clerk of the Executive Council

<i>Cemeteries Act 1958</i>			
SCALE OF FEES OF THE LEONGATHA PUBLIC CEMETERY			
In pursuance of the powers conferred upon them by the Cemeteries Act, the trustees of the Leongatha Public Cemetery hereby make the following scale of fees, which shall come into operation upon publication in the <i>Government Gazette</i> , and from and after such publication every scale of fees heretofore made by the said trustees shall be and is hereby rescinded to the extent to which it conflicts with this scale.			
			\$
Interment fees	35.00	Lawn grave, 2.44m × 1.22m, including first interment, plaque and vase	430.00
Interment outside prescribed hours, or on Saturdays, Sundays or Public Holidays or without due notice	45.00	Reopening lawn grave	290.00
Certificate of right of burial	10.00	Monumental grave, 2.44m × 1.22m, including first interment	290.00
Number plate or brick	15.00	Reopening monumental grave	210.00
Permission to erect a headstone or monument—5 per cent of cost with a minimum of \$25.00		Exhuming the remains of a body (when authorized)	200.00
Permission to construct a brick grave or to erect any stone kerb, brick tile work or concrete—5 per cent of cost with a minimum of \$25.00		Land for Public grave (sinking extra)	25.00
Exhuming the remains of a body (when authorized)	300.00	Interment of ashes in a private grave	30.00
Interment of ashes in a private grave	35.00	Permission to erect a headstone or monument—5% of cost with a minimum of \$10.00	
			H. E. MARSHMAN, Trustee R. MURPHY, Trustee H. K. WIGHTMANS, Trustee

J. ALLEN, Trustee
P. QUIRKE, Trustee
E. J. MARRIOT, Trustee

Approved by the Governor in Council, 23 April 1985—L. G. HOUSTON, Clerk of the Executive Council

Approved by the Governor in Council, 23 April 1985—L. G. HOUSTON, Clerk of the Executive Council

Cemeteries Act 1958
SCALE OF FEES OF THE PYRAMID HILL PUBLIC CEMETERY

In pursuance of the powers conferred upon them by the Cemeteries Act the trustees of the Pyramid Hill Public Cemetery hereby make the following scale of fees, which shall come into operation upon publication in the *Government Gazette*, and from and after such publication every scale of fees heretofore made by the said trustees shall be and is hereby rescinded to the extent to which it conflicts with this scale.

Cemeteries Act 1958
SCALE OF FEES OF THE WINCHELSEA PUBLIC CEMETERY

In pursuance of the powers conferred upon them by the Cemeteries Act the trustees of the Winchelsea Public Cemetery hereby make the following scale of fees, which shall come into operation upon publication in the *Government Gazette*, and from and after such publication every scale of fees heretofore made by the said trustees shall be and is hereby rescinded to the extent to which it conflicts with this scale.

	Main Cemetery	Lawn Cemetery	Miscellaneous	
	\$	\$		
Land for Private Grave 2.44m × 1.22m	120	150	Interment fee	35.00
Interment fee (per burial)	30	30	Interment not in prescribed hours or on Saturdays, Sundays, Public Holidays or without due notice	50.00
Burials carried out or involving grave digging or attendance on Saturdays, Sundays and public holidays—extra fee	50	50	Late fee (per half hour or part thereof in excess of first fifteen minutes)	10.00
Exhumation (when authorised)	300	300	Certificate of Right of Burial	7.00
Fee for permit for erection of any fence, vault, tomb headstone or other monument	20	20	Number Plate or Brick	12.00
Interment of ashes in designated areas:			Annual maintenance (single grave) if required by holder of Right of Burial (Optional)	35.00
Land (one lot)	50		Permission to erect a headstone or monument—5% of cost with a minimum of \$10.00	
Supply and erection of plaque and base	100		Permission to construct a brick grave or to erect any stone kerb, brick tilework or concrete	25.00
All sinking of graves for interments and exhumations (when authorized) are arranged by the Funeral Director.			Grave renovations or additional inscription	15.00
J. V. GUYE, Trustee			Interment of ashes in a private grave	35.00
J. W. CALDOW, Trustee			Memorial Wall Niche (40 year tenure)	80.00
G. M. CROUCH, Trustee			Bronze Plaque with Standard 3 lines of lettering	40.00
Approved by the Governor in Council, 23 April 1985—L. G. HOUSTON, Clerk of the Executive Council			Extra line of lettering	6.00
			Interment of Ashes in a Memorial Wall	20.00
			Niche Vase	20.00

J. B. MACDONALD, Trustee

G. D. RILEY, Trustee

J. M. TURNER, Trustee

R. J. BROWN, Trustee

Approved by the Governor in Council, 23 April 1985—L. G. HOUSTON, Clerk of the Executive Council

Cemeteries Act 1958

SCALE OF FEES OF THE DROMANA AND FLINDERS PUBLIC CEMETERIES

In pursuance of the powers conferred upon them by the Cemeteries Act the trustees of the Dromana and Flinders Public Cemeteries hereby make the following scale of fees, which shall come into operation upon publication in the *Government Gazette*, and from and after such publication every scale of fees heretofore made by the said trustees shall be and is hereby rescinded to the extent to which it conflicts with this scale.

Public Graves

	\$
Interment in grave without exclusive right—stillborn child	35.00
Interment in grave without exclusive right—other	70.00
Number Peg or Label	10.00

Private Graves

Land, 2.44m × 1.22m	180.00
Own selection of site (extra)	60.00
<i>Sinking Charges for Private Graves</i>	
Sinking grave 1.83m deep	180.00
Each additional 0.3m	30.00
Sinking oversize grave (extra)	50.00
Cancellation of order to sink (if commenced)	50.00
Reopening grave (no cover)	180.00
Reopening grave (with cover or kerb)	200.00

NOTICE TO MARINERS

No. 20r of 1985

AUSTRALIA—VICTORIA

The following information which has been received from the Harbor Master, Geelong is published for general information.

Port of Geelong Authority

Geelong—Victoria

Point Wilson—Works in Progress

Position: Point Wilson Explosives Pier Back Lead Lat. 38° 05' 9" S Long. 144° 32' 1" E (approx.)

Area: A line at right angles to the pier, 021° T, 305 m from the above position, thence 291° T, to the shore. This area comprises the north westerly segment of the prohibited area adjacent to the pier.

Details: Within this area floating plant will be moored, and will be marked by fixed riding lights and a buoy showing a white flashing light. Boats should not enter the area.

R. M. PERRY

Port Officer

Port of Corner Inlet and Port Albert

Ports and Harbors Division
168 Exhibition Street
Melbourne, 3000, 17 April 1985

NOTICE TO MARINERS
No. 19 of 1985

AUSTRALIA—VICTORIA
Corner Inlet
Lewis Channel

No. 4 Pile Light—Construction Completed
Former Notice: No. 45 T of 1984 refers and is cancelled.

Date: On or about 29 April 1985.

Details: Construction on the new No. 4 Pile Light structure (Lat. 38° 44. 8' S., Long 146° 25. 6' E. approx.) has been completed.

The height of the light has been increased to 9.5 metres. Other characteristics remain unchanged.

Abridged Description: Iso. 2 s. 9. 5 m 8 M.

The old No. 4 Pile Light structure will be removed when the new No. 4 Pile Light is operative.

Charts Affected: Aus. 181, Aus. 182.

Publication Affected: *Sailing Directions, Victoria* 1970. Pages 449, 465, 664.

R. M. PERRY
Port Officer
Port of Corner Inlet and Port Albert

Ports and Harbors Division
168 Exhibition Street
Melbourne, 3000, 15 April 1985

RURAL WATER COMMISSION
Water Restrictions—Brim

As from Saturday, 20 April 1985, until further notice, Stage 2 of Water Restrictions By-Law No. 5937 as amended by By-Law No. 5968 will apply in Brim (being part of the Southern Wimmera Urban District). These restrictions require that water will not be used:

- (a) to water any private garden or any commercial and industrial garden by means of fixed sprinklers except between 7.00 a.m. and 10.00 a.m.;
- (b) to water any public garden or any sports ground by means of fixed sprinklers except between 7.00 a.m. and 10.00 a.m. provided however that where an automatically controlled watering system has been installed 12 midnight and 3.00 a.m. shall be substituted for the foregoing hours;
- (c) to water any nursery or market garden or to cool any commercial poultry building by means of fixed sprinklers except between 6.00 a.m. and 9.00 p.m.;
- (d) to fill any tanker unless such water is required for domestic use or stock and taken from a standpipe hydrant stopcock or other point of supply authorized by the Commission and only between 8.00 a.m. and 8.00 p.m. on any day provided however that—
 - (i) water for purposes other than for domestic use or stock may be taken between the

foregoing hours subject to the prior written authority of the Commission to such filling being first obtained; and

- (ii) where such water is required to fight any fire or to flush any street gutter or drain for public health purposes, filling may occur at any time;
- (e) to operate any fountain or water display.

Penalty for Infringement

Persons who are detected misusing water while these restrictions are in force are liable to a maximum fine of \$1000 and may have the supply of water to their properties cut off.

Any enquiries should be directed to the Rural Water Commission, Murtoa, Office phone No. 85 2240.

D. J. CONSTABLE
General Manager

Department of Conservation, Forests and Lands
Reference Areas Act 1978

DIRECTIVES FOR MANAGEMENT

Korong Vale Reference Area—Plan No. M-250.0059

The boundary of the above Reference Area is shown in the plan quoted above which is in the Department of Conservation, Forests and Lands, Drafting Service Branch, 250 Victoria Parade, East Melbourne.

The above Reference Area was proclaimed by the Governor in Council on 19 March 1985 and published in the *Victoria Government Gazette* on 20 March 1985.

The plan for protection, control and management of the Reference Area has been approved by the Minister for Conservation, Forests and Lands and a copy of the plan is lodged and is available for inspection at the Department of Conservation, Forests and Lands, 240 Victoria Parade, East Melbourne.

The Minister for Conservation, Forests and Lands has issued the following directives for management of the Reference Area:

Directives

1. The managing authority is to comply with the prescriptions for protection, control and management of the reference area contained in the plan which has been approved by the Minister for Conservation, Forests and Lands.
2. Entry of persons into the reference area is prohibited, except for management personnel and others approved by the Minister.
3. Research work in the reference area is to be carried out in accordance with conditions set down by the Minister.
4. Grazing, mining, mineral exploration, harvesting of forest produce, quarrying, bee-keeping, educational use, recreation activities, and all forms of harvesting (except water from the areas) are prohibited.

JOAN E. KIRNER
Minister for Conservation, Forests and Lands

*Private Agents Act 1966*NOTICE OF RECEIPT OF APPLICATIONS FOR LICENCES UNDER THE PROVISIONS OF THE
PRIVATE AGENTS ACT 1966

The Clerk(s) of the Magistrates' Court(s) as listed hereunder hereby give notice that applications, as under, have been lodged for hearing by the said Court(s) on the date(s) specified.

Any person desiring to object to any of such applications must—

- (a) lodge with the respective Clerk of the Magistrates' Court a notice in the prescribed form of his objection and of the grounds thereof;
- (b) cause a copy of such notice to be served personally or by post upon the applicant at least three days before the hearing of the application; and
- (c) send or deliver—
 - (i) where the objection is not made by the officer in charge of the police district in which the Court is situated—a copy of the notice to such officer; and
 - (ii) where the objection is not made by the Registrar or Deputy Registrar—a copy to the Registrar.

<i>Full Name of Applicant*</i>	<i>Place of Abode of Applicant or Nominee</i>	<i>Name of Firm or Corporation</i>	<i>Address for Registration</i>	<i>Type of Licence</i>	<i>Date of Hearing</i>
MAGISTRATES' COURT, FRANKSTON					
Richards, Ian John	33 Swanpool Ave, Chelsea		33 Swanpool Ave, Chelsea	Process Server	10.5.85
Cresp, Rohan Paul	58 Seaford St, Seaford		113 Monterey Bvd, Frankston	Watchman	4.6.85
Cumisky, Brian	31 Meerlu Ave, Frankston		"	"	"
Smith, Davina Louise	4 Camp St, Chelsea		"	"	"
Van Der Wilde, Carolyn	11 Walkers Rd, Mt. Eliza		"	"	"
Wright, Andrew C.	246 Baxter—Tooradin Rd, Baxter		"	"	"
Fraser, John Alex	46 Moreton St, Frankston		"	"	"
Mathers, Dean L. B.	28 Medina Rd, Glen Waverley		"	"	"
Jarvie, Douglas Shane	6 Milford Cres, Karingal		"	"	"
Chapman, Ian Scott	3 Bush Crt, Frankston		"	"	5.6.85
Tucker, Anthony William	10 Mereweather Ave, Frankston		"	"	"
Callow, Scott Charles	24 Beleura Hill Rd, Morningson		"	"	"
Blackman, Sarah Jane	49 Fairbairn Ave, Mt. Martha		"	"	"
Roper, Peter Richard	Bentons Rd, Morningson		"	"	"
Newland, Phillip Ian	3/53-55 Frankston—Flinders Rd, Frankston		"	"	"
Boothey, Mark Shane	1066 Nepean Hwy, Morningson		"	"	"
Reilly, Ian Walter	28 Winona Rd, Mt Eliza		"	"	"
White, Karen Joy	37 Brunning Cres, Frankston		"	"	7.6.85
Pain, Christopher Basil	1/15 Reservoir Rd, Frankston		"	"	"

*Or in the case of a firm or corporation, of the Nominee

PRIVATE AGENTS—*continued*

<i>Full Name of Applicant*</i>	<i>Place of Abode of Applicant or Nominee</i>	<i>Name of Firm or Corporation</i>	<i>Address for Registration</i>	<i>Type of Licence</i>	<i>Date of Hearing</i>
MAGISTRATES' COURT, FRANKSTON—<i>continued</i>					
Berry, Maxine Joanne	1/14 Beatty Pde, Morningson		113 Monterey Bvd, Frankston	Watchman	7.6.85
Ross, Gary Ramon	40 Spring Rd, South Springvale		"	"	"
Norman, Lynette Alice	11 Bundy Crt, Frankston		"	"	"
Matthews, Stephen John	231 Hastings Rd, Somerville		"	"	"
Davis, Anne	67 Kirkwood Ave, Seaford		"	"	"
Marshall, Wayne Alan	7 Ajana La, Frankston		"	"	8.6.85
Jamieson, Melinda	24 Pastoral St, Frankston		"	"	"
Ray, Russell George	11 Sanderling Cres, Morningson		"	"	"
Lalor, Anthony George	24 Prince Edward Ave, McKinnon		"	"	"
Leithhead, Glendon Ian	23 Emanuel Dve, Seaford		"	"	"
Pratt, Jeffrey William	13 Candlebark Cres, Frankston		"	"	"
Caudry, Robyn Ann	7 Royle St, Frankston		"	"	"
Dated at Frankston 2 April 1985 F. J. MORTIMER, Clerk of the Magistrates' Court					
MAGISTRATES' COURT, KORUMBURRA					
Misale, Vincent Joseph	D. M. Scotts Rd, Korumburra		D. M. Scotts Rd, Korumburra	Process Server	23.5.85
Dated at Korumburra, 23 April 1985 J. McSWEENEY, Clerk of the Magistrates' Court					
MAGISTRATES' COURT, BROADMEADOWS					
Hines, Ronald Alan	9 Inverloch Cres, Dallas		Broadmeadows Army Camp	Watchman	16.5.85
Dated at Broadmeadows, 18 April 1985 R. BOURKE, Clerk of the Magistrates' Court					
MAGISTRATES' COURT, ALEXANDRA					
Hauser, Bruce John	Lot 51 Steavenson Rd, Buxton		23 Myrtle St, Alexandra	Watchman	3.5.85
Dated at Mansfield, 11 April 1985 W. FROUDE, Clerk of the Magistrates' Court					
MAGISTRATES' COURT, MORWELL					
Sandall, Frederick William	Lot 2 Blue Rock Rd, Willow Grove		653 Queensbury St, North Melbourne	Watchman	10.5.85
Dated at Morwell, 10 April 1985 K. G. McMAHON, Clerk of the Magistrates' Court					

*Or in the case of a firm or corporation, of the Nominee

PRIVATE AGENTS—continued

<i>Full Name of Applicant*</i>	<i>Place of Abode of Applicant or Nominee</i>	<i>Name of Firm or Corporation</i>	<i>Address for Registration</i>	<i>Type of Licence</i>	<i>Date of Hearing</i>
MAGISTRATES' COURT, OAKLEIGH					
Kiousis, Arthur Basil	Unit 1, 28 James St, Box Hill		1388 Dandenong Rd, Oakleigh	Watchman	10.5.85
Dated at Oakleigh 17 April 1985 S. WEBSTER, Clerk of the Magistrates' Court					
MAGISTRATES' COURT, SPRINGVALE					
Breen, Michael Anthony	4/26 Wilgah St, St. Kilda		11 Wardale Rd, Springvale	Commercial Sub-Agent	17.5.85
Bartils, Kevin Gordon	Lot 1 Kerry Rd, Warranwood		42 Fairview St, Springvale	Watchman	„
Dated at Springvale 18 April 1985 I. R. SIGG, Clerk of the Magistrates' Court					
MAGISTRATES' COURT, OAKLEIGH					
MacLean, Walter Thomas	70 Power Rd, Doveton		1388 Dandenong Rd, Oakleigh	Watchman	3.5.85
Dated at Oakleigh 15 April 1985 S. WEBSTER, Clerk of the Magistrates' Court					
MAGISTRATES' COURT, TRARALGON					
Parker, Glenn Andrew	Flat 1, 56 Grey St, Traralgon	T.C.M. Security	11 Wardale Rd, Springvale	Watchman	24.5.85
Dated at Traralgon 19 April 1985 T. A. GRANT, Clerk of the Magistrates' Court					
MAGISTRATES' COURT, HEIDELBERG					
Ball, Derek	24 Pine Cl, Broadmeadows		13 Bainbridge Dve, Eltham	Watchman	16.5.85
Dated at Heidelberg 10 April 1985 P. DWYER, Clerk of the Magistrates' Court					
MAGISTRATES' COURT, GEELONG					
Deppeler, Russell Hortip	Barrabool Rd, Ceres	R. Deppeler	Barrabool Rd, Ceres	Process Server	6.5.85
Dated at Geelong 15 April 1985 A. DUNLOP, Clerk of the Magistrates' Court					
MAGISTRATES' COURT, GEELONG					
Sareevic, Tom	14 May St, Hamlyn Heights		14 May St, Hamlyn Heights	Guard Agent	8.5.85
Dated at Geelong 17 April 1985 A. DUNLOP, Clerk of the Magistrates' Court					
MAGISTRATES' COURT, NORTHCOTE					
Elasmar, Walid	116 Bastings St, Northcote		116 Bastings St, Northcote	Inquiry Agent	10.5.85
„ „	„		„	Guard Agent	„
„ „	„		„	Process Server	„
Dated at Northcote 18 April 1985 R. MALONEY, Clerk of the Magistrates' Court					

*Or in the case of a firm or corporation, of the Nominee

PRIVATE AGENTS—*continued*

<i>Full Name of Applicant*</i>	<i>Place of Abode of Applicant or Nominee</i>	<i>Name of Firm or Corporation</i>	<i>Address for Registration</i>	<i>Type of Licence</i>	<i>Date of Hearing</i>
MAGISTRATES' COURT, MELBOURNE					
Williams, Marg Eward	50 Meander Rd, Hurstbridge	Wormald Security	340 Abbotsford St, North Melbourne	Watchman	15.5.85
Stavretis, Halina	6 Jolie Vue Rd, North Balwyn	TNT Security Guards	54 Racecourse Rd, North Melbourne	"	"
Rowlands, Adlai P.	6 Stella Dve, Thomastown	Wormald Security	340 Abbotsford St, North Melbourne	"	"
Osborne, Norman Francis	30 Beaconsfield Rd, Briar Hill		"	"	"
Oakford, John	11/262 Barkly St, North Fitzroy	TNT Group 4 Pty. Ltd.	11/262 Barkly St, North Fitzroy	"	"
Mayariou, Edward John	12 Percival St, Oak Park		"	"	"
Muarem, Rui	Raxedale Cres, Endeavour Hills	Roden Security Pty. Ltd.	52 Oxford St, Collingwood	"	"
McIver, Jeanette Mooneyan	42 Notre Dame Dve, Sunbury	TNT Security Guards	54 Racecourse Rd, North Melbourne	"	"
Hutcheson, Glen Richard	Unit 2/94 McLeod St, Carrum		"	"	"
Farrugia, George Anthony	3/19-21 McPherson St, East Keilor		"	"	"
Drinkwater, Walter George	14 Oldfield Gve, Gladstone Park	Wormald Security	340 Abbotsford St, North Melbourne	"	"
Charteris, James Charles	5 Innellan Rd, Murrumbena		"	"	"
Carroll, Robert Keith	6/295 Nepean Hwy, Edithvale	TNT Group 4 Pty. Ltd.	54 Racecourse Rd, North Melbourne	"	"
Carey, Brian Gregory	Apollo Caravan Park, Ballarat Rd, Sunshine	Wormald Security	340 Abbotsford St, North Melbourne	"	"
Brooks, Ingrid Maria	12 Bramwell St, Lilydale	TNT Group 4 Pty. Ltd.	54 Racecourse Rd, North Melbourne	"	"
Boumeester, John David	13 Armstrong St, Laverton	Wormald Security	340 Abbotsford St, North Melbourne	"	"
Bell, Craig Richard	26 Gregg St, Diamond Creek		"	"	"

Dated at Melbourne 16 April 1985
L. W. HUSSEY, Clerk of the Magistrates' Court

MAGISTRATES' COURT, SPRINGVALE

Oswald, David McLeod	118 Fountain Dve, Narre Warran	Armaguard	42 Fairview St Springvale	Watchman	17.5.85
----------------------	--------------------------------	-----------	---------------------------	----------	---------

Dated at Springvale 16 April 1985
B. DOBSON, Clerk of the Magistrates' Court

*Or in the case of a firm or corporation, of the Nominee

PRIVATE AGENTS—continued

Full Name of Applicant*	Place of Abode of Applicant or Nominee	Name of Firm or Corporation	Address for Registration	Type of Licence	Date of Hearing
MAGISTRATES' COURT, SPRINGVALE					
Coleman, Rodney James	11/1199 Heatherton Rd, Noble Park		11 Wardale Rd, Springvale South	Inquiry Agent	17.5.85
"	"		"	Process Server	"
Dated at Springvale, 10 April 1985 B. DOBSON, Clerk of the Magistrates' Court					
MAGISTRATES' COURT, FERNTREE GULLY					
Cowton, Gary P.	5 Athena Cl, Tullamarine		Thomas Richards & Co. Pty. Ltd., Suite 2, 5-7 Chandler Rd, Boronia	Watchman	8.5.85
Dated at Ferntree Gully, 3 April 1985 J. T. FERGUSON, Clerk of the Magistrates' Court					
MAGISTRATES' COURT, MORWELL					
Roach, Alan William	35 Reeve St, Sale		Toners Ln, Morwell	Watchman	8.5.85
Dated at Morwell, 15 April 1985 K. G. McMAHON, Clerk of the Magistrates' Court					
MAGISTRATES' COURT, PRAHRAN					
Harris, Alan Richard	2/150 Grange Rd, Fairfield	Mayne Nickless Ltd.	390 St. Kilda Rd, Melbourne	Watchman	17.5.85
Harvey, Stephen Douglas	14/55 Buckley St, Essendon	"	"	"	"
Parsons, Raymond Wesley	24 Railway Cres, Moonee Ponds	"	"	"	"
Villamar, Romeo	1/112 Walpole St, Kew	"	"	"	"
Thompson, Glen Darrell	14 Reno Rd, Sandringham	Armaguard	769 Glenferrie Rd, Hawthorn	"	"
Webb, Brian Stephen	74 Bowen Rd, East Doncaster	"	"	"	"
Constanti, Sodorri	40 Glencairn Ave, Coburg	"	749 Glenferrie Rd, Hawthorn	Process Server	"
"	"	"	"	Guard Agent	"
"	"	"	"	Inquiry Agent	"
Stamopoulos, Nicholas Steven	2 Geum St, Glenroy	"	749 Glenferrie Rd, Hawthorn	Process Server	"
"	"	"	"	Guard Agent	"
"	"	"	"	Inquiry Agent	"
Dated at Prahran, 4 April 1985 B. MEEHAN, Clerk of the Magistrates' Court					
MAGISTRATES' COURT, BOX HILL					
McNamara, Thomas Raymond	32 Cornfield Gve, Box Hill South		32 Cornfield Gve, Box Hill South	Watchman	2.5.85
Dated at Box Hill 11 April 1985 P. O'FARRELL, Clerk of the Magistrates' Court					

*Or in the case of a firm or corporation, of the Nominee

PRIVATE AGENTS—continued

Full Name of Applicant*	Place of Abode of Applicant or Nominee	Name of Firm or Corporation	Address for Registration	Type of Licence	Date of Hearing
MAGISTRATES' COURT, PRAHRAN					
French, John Martin	160 Main St, Romsey	Mayne Nickless Ltd.	390 St. Kilda Rd, Melbourne	Watchman	17.5.85
Holden, Theodore Francis	43 Henry St, Kensington	"	"	"	"
McDonald, Brian Robert	135 Gwinear Crt, Rawson	"	"	"	"
Oakes, Richard Keith	4 Shaw St, Springvale South	"	"	"	"
Parker, Norman Ross	2 Baxter St, Elsternwick	"	"	"	"
Pryor, William Joseph	6 Bullarto St, Chadstone	"	"	"	"
Berryman, Steven George	1/19 Narone Rd, Caulfield	Robert Emmett Stack	329 Punt Rd, Richmond	Commercial Sub-Agent	"
Berryman, Steven George	" "	"	"	Process Server	"
Birch, Geoffrey Mervyn	10 Kendall St, Elwood	"	10 Kendall St, Elwood	"	"

Dated at Prahran 12 April 1985
B.MEEHAN, Clerk of the Magistrates' Court

*Or in the case of a firm or corporation, of the Nominee

Drainage Areas Act 1958
NOTICE OF APPROVAL OF SPECIAL MAINTENANCE CHARGE MADE BY THE COUNCIL OF THE SHIRE OF MINHAMITE IN RESPECT OF THE CONDAH SWAMP NO. 1 DRAINAGE AREA

Notice is hereby given that on 23 April 1985 in accordance with the provisions of section 36 of the *Drainage Areas Act 1958*, the Governor in Council approved the estimate of the cost of proposed maintenance works in the Condah Swamp No. 1 Drainage Area submitted by the Council of the Shire of Minhamite and the making by the Council of a special maintenance charge on properties within the said Drainage Area for the year ending 30 September 1985.

L. G. HOUSTON
Clerk of the Executive Council

Drainage Areas Act 1958
NOTICE OF APPROVAL OF SPECIAL MAINTENANCE CHARGE MADE BY THE COUNCIL OF THE SHIRE OF MINHAMITE OF THE NORTHERN EUMERALLA DRAINAGE AREA

Notice is hereby given that on 23 April 1985 in accordance with the provisions of section 36 of the *Drainage Areas Act 1958*, the Governor in Council approved the estimate of the cost of proposed maintenance works in the Northern Eumeralla Drainage Area submitted by the Council of the Shire of Minhamite and the making by the Council of a

special maintenance charge on properties within the said Drainage Area for the year ending 30 September 1985.

L. G. HOUSTON
Clerk of the Executive Council

Co-operation Act 1981
**COMPOST CO-OPERATIVE LIMITED
APPLETREE HILL PRE-SCHOOL CO-OPERATIVE LIMITED
SIMPSON PRIMARY SCHOOL CO-OPERATIVE LTD.**

Notice is hereby given in pursuance of section 192 (8) of the *Co-operation Act 1981* and section 459 (2) of the Companies (Victoria) Code, that, at the expiration of three months from the date hereof, the names of the aforementioned societies will, unless cause is shown to the contrary, be struck off the register and the societies will be dissolved.

Dated at Melbourne 16 April 1985

W. J. KILPATRICK
Registrar of Co-operative Societies

Industrial Relations Act 1979
INDUSTRIAL RELATIONS COMMISSION OF VICTORIA

Extension of the Jurisdiction of the Hospital Pharmacists Conciliation and Arbitration Board

Notice is hereby given that an application has been lodged on behalf of the Association of Hospital Pharmacists of Victoria for an extension of the

jurisdiction of the Hospital Pharmacists Conciliation and Arbitration Board to include the occupation of pharmacists in Community Health Centres.

Notice is also given that this matter is listed for hearing before the Industrial Relations Commission of Victoria in Full Session at 9.30 a.m. on Friday, 10 May 1985 in Hearing Room No. 1, Level 18, Nauru House, 80 Collins Street, Melbourne.

A. S. DOWLING, Deputy Registrar
Industrial Relations Commission of Victoria

Co-operation Act 1981

CHANGE OF NAME OF A SOCIETY

Notice is hereby given that Monbulk Tennis Club Co-operative Limited which was incorporated as a Community Advancement Society under the above-named Act on 9 July 1968 has registered a change of its name and is now incorporated under the name of Moores Road Tennis Co-operative Limited under the said Act.

Dated at Melbourne 15 April 1985

K. J. NOLAN
Acting Deputy Registrar of Co-operative Societies

Creditors, next of kin, and others having claims against the estate of any of the undermentioned deceased persons are required to send particulars of their claims to the Public Trustee, 168 Exhibition Street, Melbourne, Vic., 3000, the personal representative, on or before 4 July 1985 after which date the Public Trustee may convey or distribute the assets having regard only to the claims of which the Public Trustee then has notice:

Bishop, William Arthur, late of St. Catherines Private Nursing Home, 7 Collins Street, Mentone, pensioner, died 21 December 1984.

Bown, John Edward, late of Flat 8, 18 Miller Street, North Fitzroy, pensioner, died 5 March 1985.

Boyd, Leonard George, late of 2/54 Chaucer Street, St. Kilda, retired, died 9 February 1985.

Cardell, Robert, formerly of 2 Liardet Street, Port Melbourne, but late of Centennial House, K.15 Raleigh Street, Windsor, railway employee, died 22 February 1985.

Crosbie, Frederick Gerald, late of 83 Eglinton Street, Moonee Ponds, gentleman, died 27 February 1985.

Guslinski, Jacek, Flat 8, 156 Station Street, Fairfield, waiter, died 9 February 1985.

Hall, Barry Douglas, also known as Harry Douglas Hall, late of 207 Moor Street, Fitzroy, building superintendent, died 6 December 1984.

Hickman, Matilda Jane, formerly of 1 Rogers Street, Coburg, but late of Kew, widow, died 12 February 1985.

Jones, Edith Irene, formerly of Flat 4, 35 Mitford Street, St. Kilda, but late of South Port Community Nursing Home Society, 18-30 Richardson Street, Albert Park, spinster, died 31 January 1985.

Keating, Marguerite Elizabeth, formerly of 11 Richmond Terrace, Richmond, but late of Banksia Court Private Nursing Home, 391-393 Maroondah Highway, Croydon, pensioner, died 27 January 1985.

Maybury, James Edward Francis, also known as James Maybury, late of Corpus Christi, 21 Mickleham Road, Greenvale, pensioner, died 14 June 1984.

Miller, Thomas, late of Flat 3, 9 Wando Grove, East St. Kilda, pensioner, died 14 December 1984.

Morrison, Kathleen Mary, late of c/o Elanora Home and Hospital, 7 Mair Street, Brighton, widow, died 16 January 1985.

Pearce, Horace Clyde, late of 4 Ethel Street, Wodonga, pensioner, died 8 January 1985.

Poultney, Robert James, formerly of "Arden Lodge", Arden Street, North Melbourne, but late of Eleanor Private Nursing Home, 582 Lower Heidelberg Road, Heidelberg, pensioner, died 7 February 1985.

Sefton, Marjorie Jessie, also known as Marjorie Sefton, formerly of 33 Havelock Street, St. Kilda, but late of Jenmar Private Nursing Home, 2 Chilcote Avenue, Malvern, widow, died 28 February 1985.

Taylor, Charlotte, formerly of Flat 50, 200 Pascoe Vale Road, Essendon, but late of Flat 50, 1 Moreland Road, Lionsville Essendon, spinster, died 8 February 1985.

Thomas, Ronald Selwyn, late of Kingston Centre, Geriatric Hospital, Warrigal Road, Cheltenham, pensioner, died 22 December 1984.

Tutty, Mary Catherine, late of 11 Creswell Avenue, Niddrie, spinster, died 20 January 1985.

Vanderklift, Dirk, late of Flat 1/16 Milne Street, Seaford, engineer, died 17 March 1985.

Vickery, Horace George, formerly of 3 Westbourne Street, Prahran, but late of Mont Park, pensioner, died 15 January 1985.

Wallace, Valda Clarice, also known as Balda Clarice Wallace, late of Ballarat, pensioner, died 26 November 1984.

Whitehead, James Alexander, formerly of 83 Woodland Street, Essendon, but late of Centennial House, 15 Raleigh Street, Windsor, retired railways employee, died 5 September 1976.

Whitmore, Robert Alexander, formerly of 34 Athol Street, Moonee Ponds, but late of Flat 2, 5 Dunlop Street, Ascot Vale, retired electrical mechanic, died 8 February 1985.

Wilson, Evelyn Ruth, late of Ballarat, pensioner, died 29 January 1985.

24 April 1985

P. T. SPENCER
Public Trustee

Creditors, next of kin and others having claims against the estate of any of the undermentioned deceased persons are required to send particulars of their claims to the Public Trustee, 168 Exhibition Street, Melbourne, Vic., 3000 or to Norman Perrin Embley of 27 Oravel Street, North Balwyn, Victoria 3103 the personal representatives on or before 4 July 1985 after which date the Public Trustee and Norman Perrin

Embley may convey or distribute the assets having regard only to the claims of which they then have notice.

Embley, Joan Edwina, late of 27 Oravel Street, North Balwyn, married woman, died 27 November 1983.
Melbourne, 24 April 1985

P. T. SPENCER
Public Trustee

Police Regulation Act Section 122

SALE OF UNCLAIMED MOTOR VEHICLE

An owner is required for a Red and Tan 1972 model Chrysler Sedan Registration No. MD 566 (W.A.) engine number A221BO1440.

The vehicle came into possession of the Police on 8 December 1984, and if not claimed, will be sold by public auction at the St. Albans Police Station Cnr. Main Rd, West and Mitchell St, St. Albans, on Tuesday, 4 June 1985 at 10.00 a.m.

S. I. MILLER
Chief Commissioner of Police

Consumer Affairs Act 1972

ORDER PROHIBITING THE SUPPLY OF
DANGEROUS GOODS

Whereas John David Hall, Director of Consumer Affairs, after having fully investigated the matter has recommended to me that the supply of goods, namely:

"A toy aeroplane with a launching device which propels the aeroplane by means of a helical spring and where, through use, the aeroplane can break to form a projectile capable, when so launched, of causing injury".

should, by reason of their being dangerous, be prohibited.

Now, therefore I, Peter Cornelis Spyker, Minister for Consumer Affairs pursuant to the powers conferred on me by Part IV, Division 1 of the *Consumer Affairs Act 1972* hereby make an Order prohibiting the supply in Victoria of goods, to wit:

"A toy aeroplane with a launching device which propels the aeroplane by means of a helical spring and where, through use, the aeroplane can break to form a projectile capable, when so launched, of causing injury".

Dated 29 April 1985

PETER CORNELIS SPYKER
Minister for Consumer Affairs

State Tender Board
Tenders for the Service
CARTAGE OF GOODS AND PARCELS
(METROPOLITAN)
Schedule No. 4/05

Tenders will be received until 8.30 a.m. on Friday, 17 May 1985 for the cartage and delivery of goods and parcels up to 30 kg. maximum weight within an area of 40 kilometre radius from the Elizabeth Street G.P.O., Melbourne, as may be sent to and/or from the various

State Government Departments from 1 July 1985 to 30 June 1986 upon the terms and conditions specified in the Schedule.

In the event of the contractor carrying out the service to the satisfaction of the Tender Board the contract may, at the option of the Board and with the consent of the contractor be extended for a further period of twelve months from 1 July 1986.

Particulars may be obtained from the Secretary to the Tender Board, by whom also any information will be afforded to persons tendering.

Tenders enclosed in the envelope provided, must be deposited in the tender-box at the Tender Board Offices, 3rd Floor, 49 Spring Street, Melbourne, 3000, or, if sent by post, postage must be prepaid and the tenders addresses to the Chairman of the Tender Board, Tender Board Offices, 49 Spring Street, Melbourne, 3000, which office they must reach not later than by first post on the date of closing of tenders. Under no circumstances will tender details be accepted by telephone.

J. M. PAWSON
Secretary to the Tender Board

APPOINTMENTS AND
RESIGNATIONS

APPOINTMENTS

His Excellency the Governor of the State of Victoria by and with the advice of the Executive Council thereof has by Order made on 23 April 1985 been pleased to make the under-mentioned appointments, viz:

Department of Conservation, Forests and Lands

Bailiff of Crown Lands

Stephen BARLOW,

to be a bailiff of Crown lands, pursuant to section 30 of the *Land Act 1958*, in respect of the Sidney Myer Music Bowl and the environs as shown hatched red on plan marked "A/18.1.85" attached to Department of Conservation, Forests and Lands correspondence No. Rs.12955, and with authority to enforce all the Regulations made with respect to the care, protection and management of the said lands.

Health Commission

Dental Technicians Licensing Committee

John Frederick ZETTL,

to be a member of the Dental Technicians Licensing Committee, pursuant to section 3 (1) (c) of the *Dental Technicians Act 1972* for a period ending 7 May 1985.

Members of the Committees of Management of Hospitals

Walter Rex IRVING,
Edenhope and District Memorial Hospital,
30 September 1985

Lalla Nanette DRYSDALE,
West Gippsland Hospital,
30 September 1985

Horst Otto Oscar RIEGER,
Eildon and District Community Hospital,
30 September 1985

Louise Mary GOURLAY,
Royal Children's Hospital,
30 September 1985

Frances Teresa WARREN,
Dandenong and District Hospital,
30 September 1985

Andrew John MARTIN,
Manangatang and District Hospital,
30 September 1985

Kerrie Anne CROFT,
Manangatang and District Hospital,
30 September 1987

to be members of the Committees of Management of the abovementioned hospitals pursuant to the provisions of section 63H (2) of the *Hospitals and Charities Act 1958*, the period of office expiring on the dates indicated.

Horst Otto Oscar REIGER,
Eildon and District Community Hospital,
1 October 1985 to 30 September 1988

to be a member of the Committee of Management of the abovementioned hospital pursuant to the provisions of section 63H (2) of the *Hospitals and Charities Act 1958*, the period of office indicated.

Members of Public Cemetery Trusts

Dorothy WHARTON,
Emerald Cemetery Trust, vice Clifford Little
(resigned).

Patrick QUIRKE,
Cranbourne Cemetery Trust, additional trustee.

Barry CHESTER,
Bridgewater Cemetery Trust, additional trustee.

Russell Ellison MACCUMBER,
Trustee of the Blackwood Cemetery Trust,
additional trustee.

Appointments pursuant to section 3 (1) of the *Cemeteries Act 1958*.

Law Department

Bailiff of the Supreme Court

Pauline SIMPSON-WHITE,
to be a Bailiff of the Supreme Court pursuant to the provisions of section 185 (1) of the *Supreme Court Act 1958* and as a Bailiff of Magistrates' Courts pursuant to the provisions of section 31A of the *Magistrates Court Act 1971*.

L. G. HOUSTON
Clerk of the Executive Council
At the Executive Council Chamber
Melbourne, 23 April 1985

Liquor Control Act 1968

APPOINTMENT OF LICENSING INSPECTORS

In accordance with the authority conferred upon me by section 6 of the *Police Regulation Act 1958*, I, Eric Archibald Mudge, Deputy Commissioner of Police, do hereby appoint under sub-section (1) of section 22 of the *Liquor Control Act 1968*, the following Officers of Police as Licensing Inspectors for the Divisions of the Police Districts as shown:

Division Number	Police District	Rank and Name
2	Glenelg	Inspector Ronald James Cronin, 13398 (vice Inspector K. W. Read, 10932 from 12.2.85)
2	Maroondah	Inspector Alan Kingsley Frowd, 13219 (from 24.3.85 to 13.4.85)
1	Moonee Ponds	Superintendent Keith Edward Preston Morahan, 11017 (vice Chief Superintendent T. P. Gilmore, 10049)
3	Westernport	Inspector Malcolm Wesson, 13259 (from 24.3.85 to 30.3.85 (continuation)) (from 21.4.85 to 11.5.85)

Dated 19 April 1985

E. A. MUDGE
Deputy Commissioner (Administration)

Liquor Control Act 1968

APPOINTMENT OF LICENSING INSPECTORS

In accordance with the authority conferred upon me by section 6 of the *Police Regulation Act 1958*, I, Eric Archibald Mudge, Deputy Commissioner of Police, do hereby appoint under sub-section (1) of section 22 of the *Liquor Control Act 1968*, the following Officers of Police as Licensing Inspectors for the Divisions of the Police Districts as shown:

Division Number	Police District	Rank and Name
1	Avondale Heights	Inspector Norman Thomas McGill, 13683 (from 5.5.85 to 1.6.85)
3	Prahran	Inspector James Greaves Simpson, 12919 (vice Chief Inspector B. J. Ritchie, 12473)

Dated 24 April 1985

E. A. MUDGE
Deputy Commissioner (Administration)

RESIGNATIONS

His Excellency the Governor of the State of Victoria by and with the advice of the Executive Council thereof has by orders made on 23 April 1985 accepted the resignations of the persons named hereunder of the offices mentioned, viz:

Health Commission

Members of the Committees of Management of Hospitals

Raye FERRIER,
as Member of the Committee of Management, Casterton Memorial Hospital as from 19 February 1985.

Raymond Charles NIGHTINGALE,
as Member of the Committee of Management, Southern Peninsula Hospital as from 10 October 1984.

Helen Joan OHLHOFF,
as Member of the Committee of Management, Healesville and District Hospital as from 6 March 1985.

Ian Laurence SCOTT,
as Member of the Committee of Management, Mildura Base Hospital as from 10 April 1985.

John Sydney STEPHEN,
as Member of the Committee of Management, Kaniva District Hospital as from 13 March 1985.

Clive John WALKER,
as Member of the Committee of Management, Healesville and District Hospital as from 8 March 1985.

Ronald Arthur Patrick YOUNG,
as Member of the Committee of Management, Healesville and District Hospital as from 13 December 1984

Harry MADDOX,
as Member of the Committee of Management, Castlemaine District Community Hospital as from 11 April 1985.

In accordance with the provisions of section 63G (1) of the *Hospitals and Charities Act 1958*.

L. G. HOUSTON
Clerk of the Executive Council

At the Executive Council Chamber
Melbourne, 23 April 1985

ORDERS IN COUNCIL

Land Act 1958

At the Executive Council Chamber, Melbourne, the
twenty-third day of April 1985

PRESENT:

His Excellency the Governor of Victoria
Mr Cathie | Mr Wilkes
Mrs Kirner | Mr Jolly

UNUSED ROADS CLOSED

His Excellency the Governor of the State of Victoria, in the Commonwealth of Australia, by and with the advice of the Executive Council of the said State, pursuant to the provisions of section 349 of the *Land Act 1958* and with the concurrence in writing of the council of the municipality concerned and that of any adjoining land owners, doth hereby close the unused roads hereinafter described, viz.:

Municipal District of the Shire of Bairnsdale—Parish of Goon Nure, being the roads indicated by hatching on plan hereunder—(Parish 2702) (Rs 12876).

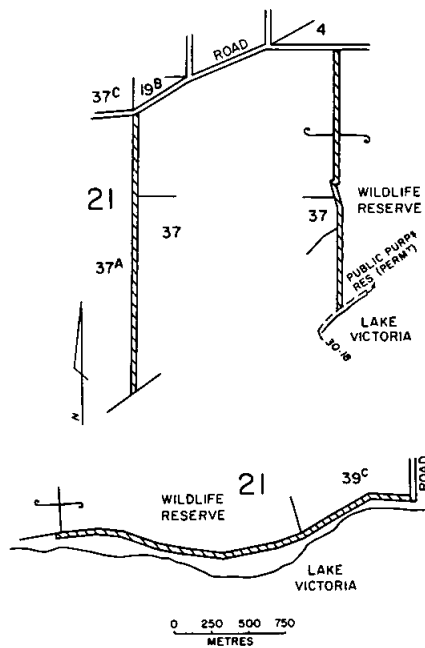

And the Honourable Joan Elizabeth Kirner, Her Majesty's Minister for Conservation, Forests and Lands for the State of Victoria, shall give the necessary directions herein accordingly.

L. G. HOUSTON
Clerk of the Executive Council

Land Act 1958

At the Executive Council Chamber, Melbourne, the
twenty-third day of April 1985

PRESENT:

His Excellency the Governor of Victoria
Mr Cathie | Mr Wilkes
Mrs Kirner | Mr Jolly

UNUSED ROAD CLOSED

His Excellency the Governor of the State of Victoria, in the Commonwealth of Australia, by and with the advice of the Executive Council of the said State, pursuant to the provisions of section 349 of the *Land Act 1958* and with the concurrence in writing of the council of the municipality concerned and that of any adjoining land owners, doth hereby close the unused road hereinafter described, viz:

Municipal District of the Shire of Ararat—Parish of Moyston, being the road indicated by hatching on plan hereunder—(M299(F3)) (J19957).

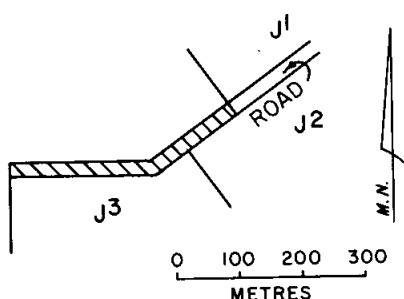

And the Honourable Joan Elizabeth Kirner, Her Majesty's Minister for Conservation, Forests and Lands for the State of Victoria, shall give the necessary directions herein accordingly.

L. G. HOUSTON
Clerk of the Executive Council

CROWN LAND (RESERVES) ACT 1978

At the Executive Council Chamber, Melbourne, the twenty-third day of April 1985

PRESENT:

His Excellency the Governor of Victoria	
Mr Cathie	Mr Wilkes
Mrs Kirner	Mr Jolly

REVOCAION OF TEMPORARY RESERVATIONS OF LANDS BY ORDERS IN COUNCIL

His Excellency the Governor of the State of Victoria, in the Commonwealth of Australia, by and with the advice of the Executive Council of the said State, pursuant to the provisions of section 10 of the *Crown Land (Reserves) Act 1978*, hereby revokes the temporary reservations of lands by Orders in Council hereinafter described, viz.

Smythesdale—The temporary reservation by Order in Council of 20 November 1865 of 174 hectares, more or less, of land in the Parish of Smythesdale for a Drainage Area of a Reservoir for Water Supply to Smythesdale, revoked as to part by various Orders, so far as regards the balance thereof is concerned—(Rs. 5077).

Smythesdale—The temporary reservation by Order in Council of 6 November 1865 of 330 hectares of land in the Parish of Smythesdale for Drainage Area of a Reservoir for Supplying Water to Smythesdale, revoked as to part by various Orders, so far as regards the balance thereof is concerned—(C71778).

And the Honourable Joan Elizabeth Kirner, Her Majesty's Minister for Conservation, Forests and Lands for the State of Victoria, shall give the necessary directions herein accordingly.

L. G. HOUSTON
Clerk of the Executive Council

CROWN LAND (RESERVES) ACT 1978

At the Executive Council Chamber, Melbourne, the twenty-third day of April 1985

PRESENT:

His Excellency the Governor of Victoria	
Mr Cathie	Mr Wilkes
Mrs Kirner	Mr Jolly

REVOCAION OF TEMPORARY RESERVATIONS OF LANDS BY ORDERS IN COUNCIL

His Excellency the Governor of the State of Victoria, in the Commonwealth of Australia, by and with the advice of the Executive Council of the said State, pursuant to the provisions of section 10 of the *Crown Land (Reserves) Act 1978*, doth hereby revoke the temporary reservations of lands by Orders in Council hereinafter described, viz.

Ararat—The temporary reservation by Order in Council of 26 May 1970 of 1.517 hectares, more or less, of land in the Township and the Parish of Ararat for Public Purposes (Drainage purposes), so far only as regards the portion thereof containing 2850 square metres, more or less, as defined by description and hatching on plan published in the *Government Gazette* dated 3 April 1985, is concerned—(A148(10)) (A149(28)) (Rs.9322).

Kerang—The temporary reservation by Order in Council of 17 July 1962 of 23.87 hectares, more or less, of land in the Parish of Kerang (in section B) for Municipal purposes, so far only as regards the portion thereof containing 5997 square metres as shown on Certified Plan No. 107011 lodged in the Central Plan Office, is concerned—(K19(9)) (Rs.8138).

Koetong (Shelley)—The temporary reservation by Order in Council of 6 September 1949 of 1.214 hectares of land in the Parish of Koetong for State School purposes, revoked as to part by Order of 5 December 1967, so far as regards the balance thereof containing 6880 square metres, is concerned—(Rs.6421).

Portland—The temporary reservation by Order in Council of 16 August 1960 of 26.30 hectares, more or less, of land in the Township of Portland (in section D) for Public Recreation, so far only as regards the portion thereof containing 2.011 hectares, as defined by description and hatching on plan published in the *Government Gazette* dated 3 April 1985, is concerned—(P69(7)) (Rs.3901).

Yackandandah—The temporary reservation by Order in Council of 20 January 1868 of 4.704 hectares, more or less, of land in the Township of Yackandandah (in section 10) for Police purposes, revoked as to part by Various Orders, so far as regards the balance thereof containing 3.247 hectares, more or less, is concerned—(Y45(17)) (Rs.1590).

St Arnaud—The temporary reservation by Order in Council of 31 March 1905 of 2023 square metres of land in the Township of St Arnaud (in section E1) for Public Gardens—(S206(10)) (Rs.527).

Terang—The temporary reservation by Order in Council of 18 July 1924 of 835 square metres, more or less, of land in the Township of Terang (in section 1) for Court House—(T85(3)) (Rs.2972).

Tyabb (Hastings)—The temporary reservation by Order in Council of 25 August 1953 of 885 square metres of land in the Parish of Tyabb (in section 94) for Police purposes—(Rs.7150).

Wongan (Lake Wongan)—The temporary reservation by Order in Council of 18 February 1890 of 230 hectares, more or less, of land in the Parish of Wongan for Public purposes—(Rs.12804).

Yackandandah—The temporary reservation by Order in Council of 2 March 1874 of 2.023 hectares of land in the Parish of Yackandandah (adjoining allotment A12) for State School purposes—(L8-3722).

And the Honourable Joan Elizabeth Kirner, Her Majesty's Minister for Conservation, Forests and Lands for the State of Victoria, shall give the necessary directions herein accordingly.

L. G. HOUSTON
Clerk of the Executive Council

CROWN LAND (RESERVES) ACT 1978

At the Executive Council Chamber, Melbourne, the twenty-third day of April 1985

PRESENT:

His Excellency the Governor of Victoria	
Mr Cathie	Mr Wilkes
Mrs Kirner	Mr Jolly

CROWN RESERVE VESTED IN THE CORPORATION OF THE SHIRE OF WALPEUP

His Excellency the Governor of the State of Victoria, in the Commonwealth of Australia, by and with the advice of the Executive Council of the said State, pursuant to section 16 (1) of the *Crown Land (Reserves) Act 1978*, hereby directs that the Crown land described in the Schedule hereunder be vested in the Corporation of the Shire of Walpeup on trust for the purposes for which the land has been reserved, and, pursuant to section 16 (2) of the said Act, also empowers the said Corporation to grant leases or licences for a term not exceeding 21 years in respect of the land for the purposes of the reservation.

Schedule

Municipal District of the Shire of Walpeup—Parish of Ouyen, being Crown allotment 29A and being the land temporarily reserved for Public Recreation by Order in Council of 19 March 1985, published in the *Government Gazette* dated 27 March 1985 (page 813)—(Rs.12865).

And the Honourable Joan Elizabeth Kirner, Her Majesty's Minister for Conservation, Forests and Lands for the State of Victoria, shall give the necessary directions herein accordingly.

L. G. HOUSTON
Clerk of the Executive Council

SUPERANNUATION ACT 1958

At the Executive Council Chamber, Melbourne, the twenty-third day of April 1985

PRESENT:

His Excellency the Governor of Victoria	
Mr Cathie	Mr Wilkes
Mrs Kirner	Mr Jolly

Pursuant to the powers conferred by the provisions of paragraph (ja) of sub-section (1) of section 3 of the *Superannuation Act 1958*, His Excellency the Governor of the State of Victoria, by and with the advice of the Executive Council thereof doth by this Order declare that the provisions of the Superannuation Act shall apply to the officers named in the schedule set out hereunder.

Schedule

Evans, Jane Susan
Ministry for Police and Emergency Services.
Broadhurst, Warren Leonard
Bunthong, Kosal
Cook, William George
Corso, Giuseppe
Heenan, Michael Joseph
Howarth, Leigh Ivan James
Howell, Stephen Roy
Jordon, Glenn Francis
Jukes, John
Langley-Bates, Peter Harry
Lloyd, Brian Phillip
Mascurine, Thomas
Maslen, George William
Millar, James Martin
McGouan, Gray Stephen
Negruj, Nikola
Parker, Brett Andrew
Parsons, Gary Thomas
Thompson, Rodney Williams
West, Gregor William
Metropolitan Transit Authority
Blakeman, Narelle
Brosnan, Bernard
Curtis, Philip
McCutcheon, Clelia
Pavic, Denise
Geach, Barbara
Giles, Derek
Howard, Leanne
Jenkins, Heather
White, Kira
Prahran College of TAFE.
Axton, Peter Leslie
Hughes, Carol Anne
Footscray College of TAFE.

Robinson, Michael
Moorabbin College of TAFE.

Lowe, Robyn Louise
Allan, John Martin
Todd, Lynette Joy
Bake, Robyn Frances
Richardson, Shelley Madeleine
Causon, Suzanne Maree
Bendigo College of TAFE.

Fowler, Janene Susan
Box Hill College of TAFE.

Marii, Mario Peter
Melbourne College of Textiles.

Kean, Francis John
Dean, Steven John
Bourke, John Charles
Road Construction Authority.

Cosier, Ian Leslie
Warrnambool Institute of Advanced Education.

Scott, Carol Ann
Gippsland Institute of Advanced Education.

Arthur, Neill Fleming
Coal Corporation of Victoria.

Nolan, Ronald Patrick
Victorian Ministry of the Arts.

Walsh, Mary Grace
Footscray Institute of Technology.

And the Honourable Robert Allen Jolly, Her Majesty's Treasurer for the State of Victoria, shall give the necessary directions herein accordingly.

L. G. HOUSTON
Clerk of the Executive Council

Water Act 1958
RURAL WATER COMMISSION OF VICTORIA

*At the Executive Council Chamber, Melbourne, the
twenty-third day of April 1985*

PRESENT:

His Excellency the Governor of Victoria	
Mr Cathie	Mr Wilkes
Mrs Kirner	Mr Jolly

DERRINAL RECREATIONAL AREA—
BOUNDARIES VARIED

Under the powers conferred by the *Water Act 1958* and all other powers enabling him in that behalf, His Excellency the Governor of the State of Victoria, with the advice of the Executive Council of the said State, on the recommendation of the Rural Water Commission of Victoria, doth hereby declare, order and direct that the boundaries of the Derrinal Recreational Area be varied by adding to the said Area the land shown by green colour on a plan numbered 6128A approved by the Governor in Council and lodged in the Plan Room of the Rural Water Commission of Victoria, at 590 Orrong Road, Armadale, and as on and from the date hereof, the boundaries of such Area shall be so varied.

And the Honourable Andrew McCutcheon, Her Majesty's Minister for Water Resources for the State of Victoria, shall give the necessary directions herein accordingly.

L. G. HOUSTON
Clerk of the Executive Council

Water Act 1958
RURAL WATER COMMISSION OF VICTORIA

*At the Executive Council Chamber, Melbourne, the
twenty-third day of April 1985*

PRESENT:

His Excellency the Governor of Victoria	
Mr Cathie	Mr Wilkes
Mrs Kirner	Mr Jolly

KIMBOLTON RECREATIONAL AREA—
BOUNDARIES VARIED

Under the powers conferred by the *Water Act 1958* and all other powers enabling him in that behalf, His Excellency the Governor of the State of Victoria, with the advice of the Executive Council of the said State, on the recommendation of the Rural Water Commission of Victoria, doth hereby declare, order and direct that the boundaries of the Kimbolton Recreational Area be varied by excising from the said Area the land shown by green colour on a plan numbered 6119B approved by the Governor in Council and lodged in the Plan Room of the Rural Water Commission of Victoria, at 590 Orrong Road, Armadale, and as on and from the date hereof, the boundaries of such Area shall be so varied.

And the Honourable Andrew McCutcheon, Her Majesty's Minister for Water Resources for the State of Victoria, shall give the necessary directions herein accordingly.

L. G. HOUSTON
Clerk of the Executive Council

Parliamentary Committees Act 1968, No. 7727
REFERENCE TO THE NATURAL RESOURCES
AND ENVIRONMENT COMMITTEE

*At the Executive Council Chamber, Melbourne, the
thirtieth day of April 1985*

PRESENT:

His Excellency the Governor of Victoria	
Mr McCutcheon	Mr Kennan
Mr Spyker	

INQUIRY INTO ACCESS TO VICTORIA'S PARKS

Whereas in section 4F of the *Parliamentary Committees Act 1968* it is amongst other things provided that a Joint Investigatory Committee is required to inquire into, consider and report to the Parliament on any proposal, matter or thing relevant to the functions of the Committee which is referred to the Committee by Order of the Governor in Council published in the *Government Gazette*.

Now therefore, His Excellency the Governor of the State of Victoria in the Commonwealth of Australia, by and with the advice of the Executive Council of the said State, and in pursuance of the powers conferred by the *Parliamentary Committees Act 1968*, doth by this Order refer the following matter to the Natural Resources and Environment Committee; namely:

To consider, make recommendations and make a final report to the Parliament before 30 June 1987 on—

1. factors influencing public usage of parks for recreational and educational purposes;
2. ways in which access to parks can be improved for all sections of community including the disadvantaged and the aged;
3. the environmental impact of park use and any usage factors affecting the long-term integrity of parks;
4. the distribution of the various categories of parks and the appropriateness of this distribution to serve community needs.

And the Honourable Joan Elizabeth Kirner, Her Majesty's Minister for Conservation, Forests and Lands for the State of Victoria, shall give the necessary directions herein accordingly.

L. G. HOUSTON
Clerk of the Executive Council

URBAN LAND AUTHORITY ACT 1979

At the Executive Council Chamber, Melbourne, the thirtieth day of April 1985

PRESENT:

His Excellency the Governor of Victoria
Mr McCutcheon | Mr Kennan
Mr Spyker

TRANSFER OF LAND—COOLAROO

Under the powers conferred by section 19 (1) of the *Urban Land Authority Act 1979*, His Excellency the Governor of the State of Victoria by and with the advice of the Executive Council thereof hereby declares that all that piece of land being part of Crown Portion G section 4 Parish of Yuroke County of Bourke, and being the whole of the land more particularly described in Certificate of Title Volume 9595 Folio 264 be transferred to the Urban Land Authority.

And the Honourable Frank Wilkes, Her Majesty's Minister for Housing for the State of Victoria, shall give the necessary directions herein accordingly.

L. G. HOUSTON
Clerk of the Executive Council

TENDERS

PUBLIC WORKS DEPARTMENT

Tenders are invited for the purposes indicated hereunder and will be received at 2 Treasury Place, Melbourne, 3002, until TWO p.m. on the dates shown.

Tenders must be addressed to the Minister of Public Works with the envelope endorsed "Tender for"

Tenders forwarded either by mail, telegram or telex, which arrive after the closing time, will be accepted provided that the official Telecom or Australia Post time and date stamping indicates dispatch prior to the closing time. (TIME AND DATE STAMPING MUST BE REQUESTED AT SOME POST OFFICES.)

NOTE: Telegram or telex submissions must be confirmed in writing.

Hand-delivered tenders must be placed in the Department's tender box in foyer, Ground Floor, 2 Treasury Place, Melbourne.

Tender documents are available from the Contracts Office, Room 29, Ground Floor, 2 Treasury Place, Melbourne and, where indicated, at offices of Inspector of Works.

★Tenders identified with a star (★) will only be considered from contractors qualified for repairs and painting works. Any tenderers wishing to qualify may obtain the application form from the Contracts Office.

Wednesday, 15 May 1985

Building, Electrical and Mechanical Services

HUNTINGDALE—Mechanical Services, Technical School.

HUNTINGDALE—Electrical Services, Technical School.

MONT PARK—Supply and installation of new dishwashing machines to wards F7-10 and F13, Mental Hospital.

MONT PARK—Supply and installation of new dishwashing machines to Wards F4, M3 and M4, Mental Hospital.

MONT PARK—Supply and installation of new dishwashing machines to Wards F2, F3, F14, M1 and M2, Mental Hospital.

★SUNBURY—Re-advertised: Internal Cyclic Maintenance to Residential Units M5A, M6, M8A (Gym), Caloola Training Centre.

Wednesday, 22 May 1985

Building, Electrical and Mechanical Services, etc.

★CHADSTONE—External Maintenance, High School.

EXHIBITION—Restoration of Facades, High School.

IRYMPLE—Trade Wing Evaporative Cooling/Heating System, Technical School. (W. O. Mildura, Swan Hill and Bendigo)

MELBOURNE—Alterations to Fifth and Eighth Floors, 221 Queen Street—Law Department.

★MIRBOO NORTH—Re-advertised: Internal and External Renovations and Painting, Primary School (W. O. Traralgon).

★PRINCES HILL—External Maintenance, High School.

PORT MELBOURNE—Contract 10, 84/85: Supply and Delivery of Modular Buildings, F.O.G., P.W.D. Storeyard—69 Salmon Street (W.O. Ballarat, Bendigo and Geelong).

Wednesday, 29 May 1985

Building, Electrical and Mechanical Services

FORREST—Erection of a New Brick Veneer Residence and Site Works, Police Residence (W.O. Geelong).

RONALD W. WALSH
Minister of Public Works

Public Works Department
Melbourne, 22 April 1985

**PRIVATE
ADVERTISEMENTS**

Town and Country Planning Act 1961

CITY OF BENALLA PLANNING SCHEME

Notice that a Planning Scheme has been Prepared and is Available for Inspection

Amendment No. 40

Notice is hereby given that the City of Benalla, in pursuance of its powers under the *Town and Country Planning Act 1961*, has prepared a scheme for including in the Planning Scheme reservations for:

- (a) No. 15 Mair Street from Residential "B" Zone to a Reserve for Public Purposes (Local Government);
- (b) Biralli House and the Carrier Street Infant Welfare Centre from Residential "B" to a Reserve for Public Purposes (Local Government);
- (c) Carrier Street Senior Citizens' Clubrooms to be rezoned from a Reserve for Public Purposes (Local Government) to a Residential "B" Zone;
- (d) The existing Crown Land Reserves for Hospital Purposes, sited in Melrose Street between Nos. 14 and No. 16 (South side) and Nos. 13 and No. 15 (North side), from Residential "B1" Zone to a Reserve for Public Purposes (Hospital).

A copy of the scheme has been deposited at the Civic Offices, Fawckner Drive, Benalla, and at the office of the Department of Planning (Plan Inspection Section), 5th Floor, 235 Queen Street, Melbourne, and will be open for inspection during office hours by any person free of charge.

Any persons affected by the Scheme are required to set forth in writing any submission they may wish to make with respect to the scheme addressed to the Town Clerk, Civic Offices, Fawckner Drive, Benalla, by 7 August 1985, and state whether they wish to be heard in respect of their submissions.

7861

JOHN F. SHAW, Town Clerk

CITY OF BOX HILL

Notice of Intention to Apply for Orders in Council Under the "*Electric Light and Power Act 1958*"

The Mayor, Councillors and Citizens of the City of Box Hill acting by and through the Council of that municipality and herein called "the applicant", hereby give notice that, for the purpose of enabling the applicant to supply consumers within the area of supply under the Shire of Nunawading Electric Lighting and Power Order No. 77 dated 20 June 1912, with electricity to be taken in bulk from Zone Sub-stations of the State Electricity Commission of Victoria, situated at Alexandra Avenue, Surrey Hills and Highbury Road in East Burwood and Burwood, the applicant intends to apply to the Governor in Council of the State of Victoria for an order under sections 10 and 11 of the *Electric Light and Power Act 1958*, authorizing the applicant to lay down or place, and to use and maintain electric lines for the above purpose within an area comprising part of Alexandra Road, Surrey Hills (City of Camberwell) and Highbury Road at East Burwood and Burwood (City of Waverley) as follows:

1. Area of Supply: (In City of Waverley). Commencing at the eastern boundary of substation "BW", thence in an easterly direction for approximately 6 metres, thence in a northerly direction for approximately 30 metres to the centre portion of Highbury Road (the common municipal boundary between the City of Waverley and the City of Box Hill).

2. Area of Supply: (In City of Camberwell).

(a) All that part of the right-of-way approximately 6 metres in width abutting upon the north boundary of the Commission's substation "SH" situated at Canterbury Road—Alexandra Avenue, Surrey Hills, for a distance of approximately 34 metres west from the western boundary of Alexandra Avenue; and

(b) All that part of Alexandra Avenue commencing at the east end of the said right-of-way and extending east therefrom approximately 10 metres to the municipal boundary of the City of Box Hill.

3. Area of Supply: (In City of Waverley). Commencing at the northern boundary of substation "EB", thence in a northerly direction for approximately 15 metres to the centre portion of Highbury Road (the common municipal boundary between the City of Waverley and the City of Nunawading).

There are no tramways or railways which the applicant proposes to break up or interfere with in accordance with the special power to be inserted in that behalf in the proposed Orders.

Copies of the draft Order and of the Order, when made can be obtained by any person at the price of One Dollar each, at the office of the Town Clerk, Municipal Office, City of Box Hill, and at the office of the State Electricity Commission of Victoria, No. 15 William Street, Melbourne.

Notices of objection and other documents may be served at the office of the applicant as aforesaid.

Every Council, company, person or persons, desirous of bringing before the State Electricity Commission of Victoria, by whom the *Electric Light and Power Act*

1958 is administered, any objection respecting the application, must do so within three months from the date of the *Government Gazette* containing this advertisement, by notice addressed to the Secretary, State Electricity Commission of Victoria, 15 William Street, Melbourne, marked on the outside of the cover enclosing it "Electric Light and Power Act 1958". A copy of every such notice must also be forwarded to the applicant for the Order.

Dated 1 May 1985

Municipal Offices, Box Hill

7894

I. G. PORT, Town Clerk

CITY OF BRUNSWICK
Road Discontinued

Whereas it is provided in section 528 (2) of the *Local Government Act 1958* that where a road (whether or not a public highway but not being a road set out on land of the Crown) or any part thereof is not required for public use, the Council of the Municipality in which such a road is situated may, not less than one month after publishing in a newspaper generally circulating in the district and posting to the registered proprietor (if any) of the land and the owners and occupiers (if any) of lands abutting or immediately adjacent to the road notice of intention to resolve that such road or part shall be discontinued.

And whereas the Council of the City of Brunswick having published or posted such notice of intention as aforesaid and having considered any objections to the proposal, has resolved that part of a road abutting 448 Moreland Road, Brunswick be discontinued.

Now therefore the Council of the City of Brunswick hereby directs that:

- (a) The said road which is shown by hatching on the plan hereunder shall be discontinued;

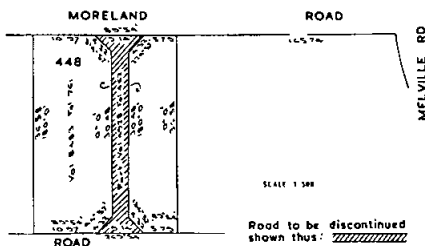

- (b) Notwithstanding such discontinuance, the Melbourne and Metropolitan Board of Works shall continue to have and possess the same right, title, power, authority or interest in or in relation to the whole of the land shown hatched on the said plan as it had or possessed prior to such discontinuance with respect to or in connection with any drains or pipes laid or erected in or over such land for the purposes of drainage or sewerage;

- (c) The publication of this resolution be effected in the *Government Gazette*; and
- (d) Thereafter subject to any such right, title, power, authority, or interest, the said part be sold to the abutting owner by private treaty.

7919

K. D. WILSON, Town Clerk

CITY OF BRUNSWICK
Road Discontinued

Whereas it is provided in section 528 (2) of the *Local Government Act 1958* that where a road (whether or not a public highway but not being a road set out on land of the Crown) or any part thereof is not required for public use, the Council of the Municipality in which such a road is situated may, not less than one month after publishing in a newspaper generally circulating in the district and posting to the registered proprietor (if any) of the land and the owners and occupiers (if any) of lands abutting or immediately adjacent to the road notice of intention to resolve that such road or part shall be discontinued.

And whereas the Council of the City of Brunswick having published or posted such notice of intention as aforesaid and having considered any objections to the proposal, has resolved that part of a road at the rear of 19 and 21 De Carle Street, Brunswick be discontinued.

Now therefore the Council of the City of Brunswick hereby directs that:

- (a) The said road which is shown by hatching on the plan hereunder shall be discontinued;

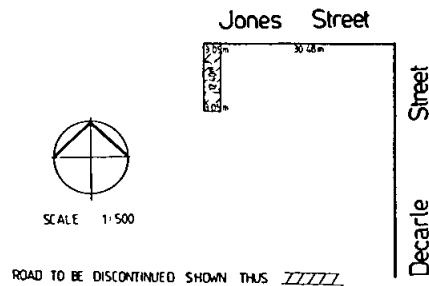

- (b) Notwithstanding such discontinuance, the Melbourne and Metropolitan Board of Works shall continue to have and possess the same right, title, power, authority or interest in or in relation to the whole of the land shown hatched on the said plan as it had or possessed prior to such discontinuance with respect to or in connection with any drains or pipes laid or erected in or over such land for the purposes of drainage or sewerage;
- (c) The publication of this resolution be effected in the *Government Gazette*; and
- (d) Thereafter subject to any such right, title, power, authority, or interest, the said part be sold to the abutting owner by private treaty.

7918

K. D. WILSON, Town Clerk

CITY OF MOORABBIN

Whereas the Council of the City of Moorabbin:

1. Is of the opinion that the Right-of-way which is shown by hatching on the plan at the foot hereof is not reasonably required as a road for public use;
2. Has consulted with the public statutory corporations referred to in section 528 (2) (e);
3. Has not less than one month before the date of this meeting published a public notice in the newspaper and given written notice to the registered proprietors of the land and the owners and occupiers of the land abutting or immediately adjacent to the said road in accordance with section 528 (2) (a) (iii);
4. Has considered objections to the proposal in accordance with section 193A.

Now the Council does hereby direct—

- (a) that the said road which is shown by hatching on the plan herewith shall be discontinued upon publication of this resolution in the *Government Gazette*;

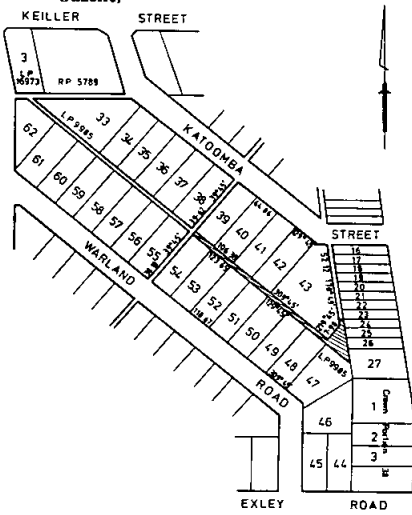

SECTION TO BE CLOSED SHOWN HATCHED

Not to Scale

- (b) that notwithstanding such discontinuance the Melbourne and Metropolitan Board of Works shall continue to have and possess the same right title power authority or interest in or in relation to the whole of the land shown by hatching on the said plan as it had or possessed prior to such discontinuance with respect to or in connection with any drains or pipes laid or erected in on or over such land for the purposes of drainage or sewerage;
- (c) that subject to any such right title power authority or interest the land in the said road shall vest in the municipality until it is sold by private treaty.

7862

CITY OF PRESTON

Road Discontinuance

Pursuant to section 528 (2) of the *Local Government Act 1958*, the Council of the City of Preston at its Ordinary Meeting of Council held on 27 August 1984, resolved that the road shown hatched on the plan below, be discontinued and sold by private treaty.

OAKOVER ROAD

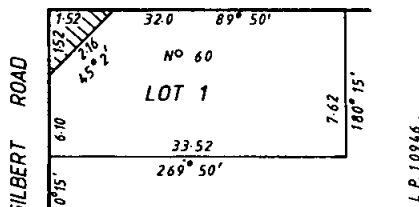

7895

D. O. McLEAN, Chief Executive Officer

CITY OF SUNSHINE

Road Discontinuance

Pursuant to section 528 (2) of the *Local Government Act 1958*, the Council of the City of Sunshine passed the following resolution at its Ordinary Meeting held on 2 April, 1985:

"This Council being of the opinion that the part of the road shown hatched and cross-hatched on the plan hereunder is not reasonably required as a road for public use, having consulted with any relevant public Statutory Authority, having published and given the notices required by section 528 (2) of the *Local Government Act 1958*, and having considered any objections to the proposal, does hereby resolve and direct that:

- (a) Such part be discontinued;
- (b) Notwithstanding such discontinuance, the Melbourne and Metropolitan Board of Works shall continue to have and possess the same right, title, power, authority or interest in or in relation to the whole of the land shown cross-hatched on the said plan as it had or possessed prior to such discontinuance with respect to or in connection with any drains or pipes laid or erected in, on or over such land for the purposes of drainage or sewerage;

DIAGRAM FOR ROAD CLOSURE

PART OF CROWN ALLOTMENT D
SECTION 7
PARISH OF MARIBYRNONG
COUNTY OF BOURKE

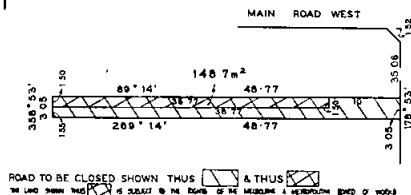

THE LAND SHOWN THUS IS SUBJECT TO THE RIGHTS OF THE MELBOURNE & METROPOLITAN BOARD OF WORKS

- (c) Publication of this resolution be effected in the *Government Gazette*; and
 (d) Thereafter, subject to any such right, title, power, authority or interest, the said part be sold to abutting owners by private treaty."

7839 G. S. PEASON, Town Clerk.

RURAL CITY OF WODONGA

In accordance with section 119 of the Sewerage Districts Act, notice is hereby given that a sewermain will be constructed through part of Lot D of L.P. No. 146115 (Federation Park—Stage 5).

Plans of the proposed works may be inspected at the Council Offices, hovell Street, Wodonga, during normal working hours.

7840 R. I. O'TOOLE, Town Clerk

SHIRE OF COBRAM

Closure of Road to Through Traffic

Notice is hereby given that the Shire of Cobram has adopted an Order pursuant to the provisions of section 539C of the *Local Government Act 1958* for the closure of River Road Cobram (Between Churr Street and Boorin Street) to vehicular traffic by the construction of a post and rail barrier as indicated on the following diagram and further that the Order shall come into operation on 13 May 1985.

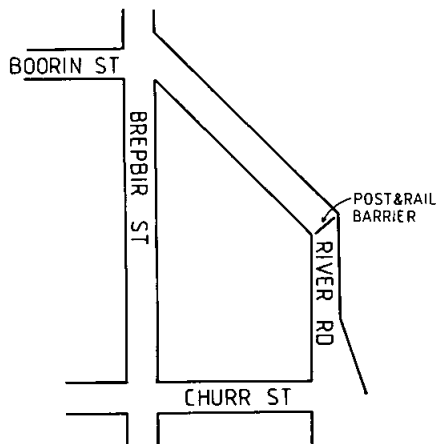

7896 W. LENYSZYN, Shire Secretary

SHIRE OF CRANBOURNE SEWERAGE AUTHORITY General Notice

The abovementioned Sewerage Authority, having made provision for carrying off the sewage from each and every property which, or any part of which, is within the Sewerage Areas, hereinafter described doth hereby declare that on and after 1 May 1985, each and every property which or any part of which, is within

the said Sewerage Area, shall be deemed to be a sewered property within the meaning of the *Sewerage Districts Act 1958* (as amended to date).

The boundaries of the Sewerage Areas hereinafter referred to are:

Declared Areas:

No. 92: Comprising Lots 1 to 19 inclusive on L.P. 28675 together with Lots 20 to 33 inclusive on L.P. No. 43292. Elizabeth Street/Huon Park Area, Cranbourne.

No. 93: Comprising Lots 1 to 64 inclusive in Seaview Drive, Bainbridge, Capri and Talba Courts being stage 1 of the Ballarto Road Estate off Ballarto Road, Carrum Downs.

No. 94: Comprising Lots 364 to 369 inclusive, Lots 380 to 388 inclusive and Lots 390-425 inclusive in the Burgess Drive, Cuneata Close, Clematis Court area being Stage 4C and 4D1 of the Langwarrin Park Subdivision, Langwarrin.

No. 95: Comprising Lots 1 to 17 inclusive in Colin Court being Stage 1 of the Cranhaven Road Subdivision, Langwarrin.

No. 96: Comprising Lots 4 to 11 inclusive together with Lots 59, 60, 65, 66 and 71, Kerry Street together with Lots 72 to 85 inclusive in Kate Court being Stage 1 of the Pine Ridge Estate situated off Cranbourne-Frankston Road, Langwarrin.

7921 T. VICKERMAN
Secretary

Form 2.1

Town and Country Planning Act 1961 SHIRE OF HEALESVILLE INTERIM DEVELOPMENT ORDER 1976

Notice that an Amendment has been Prepared and is Available for Inspection
Amendment No. 23

Notice is hereby given that the Shire of Healesville in pursuance of its powers under the *Town and Country Planning Act 1961* has prepared an Amendment for the Purpose of Incorporating Management Plans for the following areas within the Special Study Zone, into the Interim Development Order: Kalamunda Terrace Area; Lowes Road Area; Baden Powell Drive Estate; Beverley Drive/Dorothy Street Area; Juliet Crescent/Graceburn Avenue Area; Maroondah Highway/Quarry Reserve Area.

A copy of the Amendment has been deposited at the Shire Office, 231 Maroondah Highway, Healesville, at the office of the Upper Yarra Valley and Dandenong Ranges Authority, Old Melbourne Road, Lilydale West and at the office of the Ministry for Planning and Environment (Plan Inspection Section), 5th Floor, 235 Queen Street, Melbourne and will be open for inspection during office hours by any person free of charge.

Any persons affected by the Amendment are required to set forth in writing any submission they may wish to make with respect to the Amendment, addressed to The Shire Secretary, Shire of Healesville, P.O. Box 222, Healesville, 3777 by 15 June 1985 and state

whether you wish to be heard in respect of your submission.

Dated 1 May 1985

G. R. PEACOCK
Shire Secretary

7920

SHIRE OF FLINDERS

Discontinuance of Road Esplanade, Sorrento

The Council being of the opinion that the road shown shaded on the plan below is not required for public use and having consulted with the various public Statutory Authorities and published and served the notice prescribed in section 528 (2) of the Local Government Act and there being no objection, hereby directs:

- (a) that such road be discontinued;
- (b) that notwithstanding such discontinuance the Shire of Flinders shall continue to have and possess the same right or interest in or in relation to the whole of the land on the said plan as it had or possessed prior to such discontinuance with respect to any drain laid on such land for drainage purposes;
- (c) that subject to such right or interest the land be sold by private treaty.

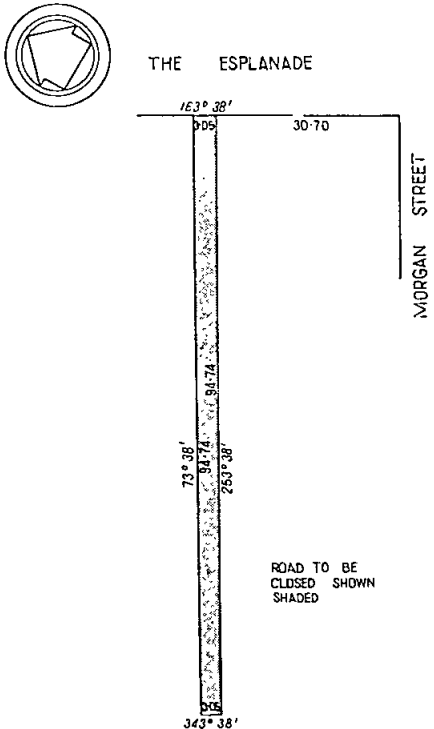

7897 LARRY M. JONES, Shire Secretary

SHIRE OF MAFFRA
Vesting of Reserve

Whereas it is provided by section 569BA of the Local Government Act 1958, that where any map or plan has been lodged or deposited with the Registrar of Titles pursuant to section 97 of the Transfer of Land Act 1958, whether before or after the commencement of this section and any allotment on that plan has been transferred, the Council may by resolution direct that the whole or any part of the land comprised in any Reserve shown on that map or plan shall vest in the Council and upon publication of that resolution in the Government Gazette, that land shall vest in the Municipality freed and discharged from any mortgage, charge, lease or sub-lease.

Accordingly, the Council resolved on 16 April 1985 that the Reserve coloured green on the plan of Subdivision No. 91483 lodged in the office of Titles shall vest in the Council of the Shire of Maffra.

7841 J. RENNICK, Shire Secretary

SHIRE OF NARRACAN
Resolution Discontinuing a Road

The Council of the Shire of Narracan being of the opinion that the road described in the schedule is no longer required for public use and is not set out in land of the Crown, and having complied in all respects with Sub-Section (a) (iii) of section 528 of the Local Government Act 1958, and there being no objections to the proposed discontinuance of the said road, doth hereby resolve that the said road be discontinued and the land being the road so discontinued shall vest in the Shire of Narracan and be sold by agreement.

Schedule

All that piece of land containing 690 square metres shown as hatched on the Plan hereunder being part of Crown Allotment 104 Parish of Moe and being part of the land in Certificate of Title Volume 3532 Folio 260.

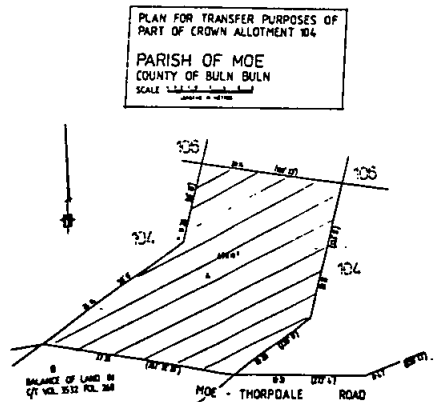

Municipal Chambers
Trafalgar, 3824
7898 W. F. NELSON, Shire Secretary

SHIRE OF NARRACAN
Willow Grove Sewerage District
Declaration of Sewered Area No. 1

The Shire of Narracan having made provision for carrying off the sewage from each and every property which or any part of which is within the sewerage area hereinafter described doth hereby declare that on and after 1 May 1985 each and every property which or any part of which is within the said sewerage area shall be deemed to be a sewered property within the meaning of the *Sewerage Districts Act 1958*.

The boundaries of the sewerage area hereinbefore referred to are shown on Plan No. 2116/24 held in the Municipal Offices, Princes Highway, Trafalgar and described as Sewered Area No. 1.

Further particulars regarding the streets or part of streets in which sewers have been laid may be ascertained on enquiry at the Municipal Office, Trafalgar.

7899 W. F. NELSON, Shire Secretary

Form 2. 1
Town and Country Planning Act 1961
SHIRE OF PAKENHAM PLANNING SCHEME
PART 1, AMENDMENT No. 39
Notice that a Planning Scheme has been Prepared and is Available for Inspection

Notice is hereby given that the Shire of Pakenham in pursuance of its powers under the *Town and Country Planning Act 1961* has prepared a Scheme for the rezoning of land being:

Portion of the Parish of Nar Nar Goon as shown on Map 25 of the Principal Scheme and being the land included in Crown Allotment 8, section A, Lots 1 and 2, L.P. 77061, and part Crown Allotment 88D in the said Parish with frontage to Carney Street, Nar Nar Goon from Part Commercial 1 and Part Residential 4 to Residential 2 zone.

A copy of the Scheme has been deposited at the Shire Offices, Henty Way, Pakenham, 3810 and at the office of the Ministry of Planning and Environment (Plan Inspection Section), 5th Floor, 235 Queen Street, Melbourne, and will be open for inspection during office hours by any person free of charge.

Any persons affected by the scheme are required to set forth in writing any submission they may wish to make with respect to the Scheme addressed to the Shire Secretary, Shire of Pakenham, P.O. Box 7 Pakenham, Victoria 3810 by 5 June 1985 and state whether you wish to be heard in respect of your submission.

7842 B. J. WALLIS, Shire Secretary

SHIRE OF ROSEDALE
By-Law No. 59

Building Regulations By-Law

Notice is hereby given that the Shire of Rosedale has made By-Law No. 59 under the *Building Control Act 1981* and the Victorian Building Regulations 1983 for:

- (a) adopting the requirements specified in column 3 of Table 11.6 of the said Regulations as the minimum requirements applying to an allotment and the siting of any class I building thereon;

- (b) adopting the requirements specified in column 5 of Table 11.6 of the said Regulations as the minimum requirements applying to an allotment and the siting of any class II building thereon;
- (c) specifying the minimum distance of the outer walls of any class I or II buildings from frontage in excess of that provided in Table 11.6 of the said Regulations;
- (d) exempting any class Xb or Xc building which is to be constructed on farm land and used for farming purposes;
- (e) repealing By-Laws Nos. 31 and 53.

The resolution for passing this By-Law was agreed to by Council on 17 December 1984 and was confirmed on 21 January 1985.

A copy of the By-Law is open for inspection at the Shire Offices, Cansick Street, Rosedale.

7900 P. L. TATTERSON, Shire Secretary

SHIRE OF ROMSEY
By-Law No. 39

A By-Law made under the Victoria Building Regulations 1983, and numbered 39 for the purpose of specifying siting requirements for Class I, II and X Buildings.

The resolution for passing this By-Law was agreed to on Wednesday, 13 February 1985 and confirmed on Wednesday, 17 April 1985.

A copy of the By-Law is open for inspection free of charge, during office hours at the Office of the Council, Main Street, Romsey.

Dated 18 April 1985

The common seal of the President, Councillors and Ratepayers of the Shire of Romsey was hereunto affixed in the presence of—

J. T. GREEN, President
R. M. CLEMENT, Councillor
B. F. CARNE, Shire Secretary

7843

SHIRE OF ROMSEY
Section 569BA (1) *Local Government Act 1958*,
Vesting Order

Whereas plan of subdivision number 128897 was sealed by the Shire of Romsey on 12 July 1978, and lodged with the Registrar of Titles pursuant to section 97 of the *Transfer of Land Act 1958* and whereas Lot 1 of the plan was transferred to S. J. & M. E. Newland on 4 April 1979, the Council of the Shire of Romsey hereby directs that the whole of the land on the plan comprised within the area shown as "Reserve for Municipal Purposes" shall vest in the Council.

Dated 17 April 1985

The common seal of the President, Councillors and Ratepayers of the Shire of Romsey was hereunto affixed in the presence of—

J. T. GREEN, President
R. M. CLEMENT, Councillor
B. F. CARNE, Shire Secretary

7844

Notice—Erratum
SHIRE OF WERRIBEE

Vesting of Reserve Adjacent to the Werribee River and forming part of Crown Allotments D, E and F Section 1 Parish of Tarneit County of Bourke

On page 3197 of the *Victoria Government Gazette*, No. 96 published on 12 September 1984 a vesting order pursuant to the provisions of section 569 (B) (A) of the *Local Government Act 1958* was published in respect of the abovementioned reserve. That order referred to Lodged Plan No. 144774 which should have been Lodged Plan No. 144775.

7845

J. T. KERR, Shire Secretary

GEELONG AND DISTRICT WATER BOARD

Pursuant to section 60 of the *Geelong Waterworks and Sewerage Act 1958* (No. 6263) the Board has prepared plans to indicate the particulars of sewers and underground works, the construction of which the Board intends to begin at a date not less than one month after publication of the notices, in or adjacent to the following localities within the Drainage Area.

Edol and Dunn Streets, North Geelong, Shire of Corio.

Braund Avenue, Ward Street, Bell Post Hill, Shire of Corio.

Notice is hereby given that the plans indicated are open for public inspection at the Board's Offices, 61-67 Ryrie Street, Geelong between the hours of 8.10 a.m. and 5.00 p.m. from Monday to Friday (public holidays excepted) by the owners or occupiers of land or premises within the Drainage Area.

7901

R. A. JORDAN, Secretary

DR CHING TSIANG/MORNINGSIDE PTY. LTD.

The owner of the premises at 412 Toorak Road, Toorak.

We, Graeme Victor Warne and Beryl Ruth Warne give you notice pursuant to clause 3 (f) of the lease of the property known as Suite 5, 412 Toorak Road Toorak dated 6 January 1983 that we wish to renew the said lease for a further term commencing on 6 January 1986 at a rental to be determined in accordance with clause 3 (f) of the said lease.

Dated 22 April 1985

7902

G. V. WARNE
B. R. WARNE

BALLARAT WATER BOARD

Pursuant to section 119 (2) of the *Sewerage Districts Act 1958*, (No. 6368) notice is hereby given of the intention to construct a sewer for property situated in the vicinity of the following streets:

Shire of Grenville

Glenelg Highway and Valerie Court

City of Ballarat

Valentine and Winter Streets

Richards and Fussell Streets

Sturt and Raglan Streets

more particularly as shown on plans which are open for inspection at this Office between the hours of 8.45 a.m. and 4.30 p.m., Monday to Friday, inclusive.

7939

B. E. LEACH, Secretary

Notice is hereby given that M.T.S.H. Nominees Pty. Ltd. has applied for a lease pursuant to section 135 *Land Act 1958* for a term of 5 years in respect of Allotment 1c section B Parish of Doutta Galla City of Melbourne for storage of Vehicles and Equipment.

7863

Notice is given that the partnership between Momir Popovic, Georgina Lalicic and Tomislav Stankovic who conducted the business of the "Rubin Queen" restaurant at 90A Acland Street, St. Kilda was dissolved by mutual consent on 1 April 1985. All debts due and owing by the late firm will be received and paid by Momir Popovic who will continue to carry on the business at the same place.

Dated 25 April 1985

7903

NOTICE OF DISSOLUTION

Notice is hereby given that the partnership heretofore subsisting between Con Skapetis, Sia Skapetis and Cuggi (Aust.) Pty. Ltd., carrying on business as manufacturers under the business name of Consia Knitting at 17 Norfolk Court, North Coburg, has been dissolved by Cuggi (Aust.) Pty. Ltd., with effect from 22 July 1985.

Dated 22 April 1985

ISSAC BROTT & CO., solicitors, 113-115 Victoria Street, Fitzroy, Tel. 419 4277

7904

NOTICE OF DISSOLUTION

Notice is hereby given that the partnership heretofore subsisting between Con Skapetis, Sia Skapetis and Cuggi (Aust.) Pty. Ltd., carrying on business as manufacturers under the business name of Consia Knitting at 17 Norfolk Court, North Coburg, has been dissolved by Con Skapetis with effect from 22 July 1985.

Dated 22 April 1985

ISSAC BROTT & CO., solicitors, 113-115 Victoria Street, Fitzroy, Tel. 419 4277

7905

Companies (Victoria) Code

Sub-regulation 137 (1)

Notice of Intention to Declare a Dividend
KEITH WILSON GROUP PTY. LTD. (IN
LIQUIDATION)

A first and final dividend is to be declared on 7 June 1985 in respect of the Company.

Creditors whose debts or claims have not already been admitted are required on or before 24 June 1985 formally to prove their debts or claims. In default, they will be excluded from the benefit of the dividend.

Dated 24 April 1985

R. M. H. Cole, Liquidator

Robert M. H. Cole & Co., 499 Bourke Street, Melbourne, 3000

7869

Unclaimed Moneys Act 1962

Register of Unclaimed Moneys held by the—

<i>Name of Owner on Books and Last Known Address</i>	<i>Total Amount Due to Owner</i>	<i>Description of Unclaimed Money</i>	<i>Date when Amount first became Payable</i>
\$			
AMATIL LIMITED			
Adair, Meredith J., 387 Erica Rd, Heathfield, S.A.	75.60	Cheque	18.3.83
Aiken, Amy C. W., P.O. Box 227, Port Macquarie, N.S.W.	786.24	"	"
Allen, Marion B. (estate of), c/o P. S. Shadforth & Son, G.P.O. Box 591F, Hobart, Tas.	144.00	"	"
Anderson, Wendy S. M., 11 Golden Grv, Red Hill, A.C.T.	14.40	"	"
Archos, Dr Keith R., 499 Old Cleveland Rd, Camp Hill, Qld.	46.64	"	15.2.84
Armit, Colin E. (estate of), c/o Jagelman & Small, Level 40, Tower Bld, Australia Square, Sydney, N.S.W.	447.72	"	18.8.83
Baker, Ernest R. G. (estate of), c/o J. C. Petrie & Co, 2nd Floor, 139 King St, Sydney, N.S.W.	75.60	"	"
Bampton, Jane R., 29 Mikado St, Hamilton, Qld.	110.00	"	15.2.84
Barnes, Ellen R., cnr Peek & Plant Sts, Charters Towers, Qld.	22.40	"	18.8.83
Beazly, Rodger A., 51 Parkhurst Rd, Bexley, Kent, England	10.75	"	15.2.84
Bellbrook Investments Pty. Limited, Junction St, Nowra, N.S.W.	40.48	"	"
Bellman, Charles S., 28 Mettam St., Trigg, W.A.	47.04	"	18.8.83
Bentley, Charles D., c/o 30 Hale St, North Beach, W.A.	30.24	"	"
Berriman, David W., 2A Rooke Lne, Hunters Hill, N.S.W.	22.40	"	"
Bing, Susan G. J. and Davidson, Rodney D., c/o Home Wilkinson & Lowry, 401 Collins St, Melbourne	59.40	"	15.2.84
Bool, Arthur K., 763 High St, Epping	14.40	"	18.8.83
Bourke, Patricia M., c/o G.P.O. Box 145, Sydney, N.S.W.	56.28	"	"
Boyce, Michael, c/o Share Department, G.P.O. Box 145, Sydney, N.S.W.	30.66	"	"
Bradley, Alison W., Ongaonga, No. 1 RD, Waipawa, Hawkes Bay, N.Z.	21.32	"	15.2.84
Bradley, Ian W., 17/234 Pacific Hwy, Lindfield, N.S.W.	120.96	"	18.8.83
Broderick, Alice V., 3 Laura St, Brunswick	13.20	"	15.2.84
Broderick, Leslie G., 3 Laura St, Brunswick	13.20	"	"
Browne, Edith A., 35 Regent St, Maitland, N.S.W.	19.80	"	"
Buckley, Eric N., c/o G.P.O. Box 145, Sydney, N.S.W.	236.04	"	18.8.83
Bush, A. (estate of) and M. M. (estate of), c/o Elrington & Elrington, P.O. Box 15, Yass, N.S.W.	36.00	"	"
Cameron, Philip J., 10 Cowper St, Longueville, N.S.W.	24.00	"	"
Carmine, Alban B., 64 Herbert St, Masterton, N.Z.	1056.72	"	"
Carmine, Alban B. and Catherine A., 64 Herbert St, Masterton, N.Z.	411.26	"	"
Carmine, David, c/o Alban B. Carmine, 64 Herbert St, Masterton, N.Z.	77.11	"	"
Carmine, Stephen, c/o Alban B. Carmine, 64 Herbert St, Masterton, N.Z.	179.93	"	"
Chalmers, Robyn L., Lot 16, Caroline Cres, Hurstbridge	30.24	"	"
Chen, Elanor, 537 Kent St, Sydney, N.S.W.	396.00	"	15.2.84
Chirlian, Brian N., "Chanbry", Wallabadah, via Quirindi, N.S.W.	47.04	"	18.8.83
Clarke, Ethel R., c/o E. E. Ellis, 34 Lucinda Ave, Wahroonga, N.S.W.	31.68	"	15.2.84
Clifford-Baynes, Mary S., Chested Farm, Chiddingstone, Near Edenbridge, Kent, England	114.58	"	18.8.83
Collard, Sarah J. and Rev Richard McD., 82 Lyons St, Carnegie	56.10	"	"
Cotton, Elizabeth S., Woodgrange, Downpatrick, Co Down, Ireland	27.62	"	30.4.83
Crombie, Esther K., P.O. Box 8, Nuhaka, Hawkes Bay, N.Z.	23.56	"	18.8.83
Davies, Mabel, c/o Share Department, G.P.O. Box 145, Sydney, N.S.W.	42.21	"	"
Dean, Wilfred E., 7 Courtenay Rd, Rosebay, N.S.W.	72.00	"	"
Drummond, Annie G. and Faber, Ronald F., c/o New Zealand Insurance Company Limited, P.O. Box 953, Whangarei, N.Z.	286.70	"	"

Unclaimed Moneys Act 1962

Register of Unclaimed Moneys held by the—

<i>Name of Owner on Books and Last Known Address</i>	<i>Total Amount Due to Owner</i>	<i>Description of Unclaimed Money</i>	<i>Date when Amount first became Payable</i>
\$			
AMATIL LIMITED— <i>continued</i>			
Ducrou, Audrey M. (estate of), 2/9 Lockwood St, Asquith, N.S.W.	30.24	Cheque	18.3.83
Duncan, Constance I. A. (estate of), c/o Johnston & Tinsey, P.O. Box 104, Warialda, N.S.W.	62.20	"	"
Elb, Florence M. (estate of), c/o C. P. White & Sons, Manchester Unity Building, 160 Castlereagh St, Sydney, N.S.W.	100.80	"	"
Ellerker, Dennis A. W., 8 Ryrie St, Mosman, N.S.W.	13.86	"	15.2.84
Ellis, Andrew G., 98 Flemington Rd, Parkville	37.80	"	18.8.83
Eslick, Alva R., Point Rd, Mooney Mooney, N.S.W.	177.40	"	"
Evans, Sheila M. and Murphy, Margaret P., 8 Keating St, Lidcombe, N.S.W.	28.00	"	"
Everitt, Eleanore H., 14/20-22 Coogee Bay Rd, Randwick, N.S.W.	72.00	"	"
Evans, Margaret N., 7 Briar Ave, Medindie, S.A.	99.75	"	"
Ferguson, Elsie C. (estate of), c/o Share Department, G.P.O. Box 145, Sydney, N.S.W.	51.87	"	"
Field, Deborah J., 5 Walker St, Doncaster	19.80	"	15.2.84
Fischer, Simon H., 46 Streeton Cres, East Ivanhoe	55.00	"	"
Flynn, Katherine I., c/o S. H. Henderson, 195 Macquarie St, Sydney, N.S.W.	30.24	"	18.8.83
Gilbert, Graeme L., 2 Fenton Rd, Enfield, S.A.	315.00	"	"
Girling, David T., 37 Belmont Ave, Wollstonecraft, N.S.W.	347.76	"	"
Gleeson, Pauletta, 34 Roseberry Rd, Killara, N.S.W.	40.40	"	"
Goldberg, Joan A., c/o National Bank of Australasia Ltd., Canberra, A.C.T.	33.10	"	"
Gordon, George H. and Hone, Geoffrey W., c/o Blake & Riggall, 140 William St, Melbourne	39.65	"	30.4.83
Graham, Geoffrey H., P.O. Box 111, Queen Victoria Building, Sydney, N.S.W.	15.40	"	18.8.83
Graham-Stewart, John C., Mulberry Grange, St. Boniface Rd, Ventnor, Isle of Wight, England	14.02	"	15.2.84
Grimwade, Gay L. N., "Boolarong", Nagambie	90.72	"	18.8.83
Hall, Edward G., 23 Nelson St, Petone, N.Z.	35.87	"	"
Harrison, Julie A., c/o M. McNeven, Macgregor, Qld.	10.78	"	15.2.84
Hayne, Charles G. and Janet M., Torakina, P.O. Box 98, Keith, S.A.	66.00	"	"
Heath, Elizabeth A., 48 Lower Iluka Rd, Mosman, N.S.W.	62.80	"	18.8.83
Heller, Ernest, and Josephine, 36 King St, Caloundra, Qld.	143.00	"	15.2.84
Henshaw, Gordon W., c/o Share Department, G.P.O. Box 145, Sydney, N.S.W.	60.48	"	18.8.83
Herbert Park Pty. Ltd., c/o A. E. Cobcroft, 14-17 Albert St, Edgecliff, N.S.W.	231.84	"	"
Hess, Margaret V., 1/35 Young St, Neutral Bay, N.S.W.	95.04	"	15.2.84
Hill, Raymond, c/o Bank of N.S.W., 341 George St, Sydney, N.S.W.	60.48	"	18.8.83
Holm, Clifford N., 65 Wallace St, West Brunswick	21.42	"	"
Humphreys, Lorraine M. A. and Thomas A., P.O. Box 39, Galston, N.S.W.	57.75	"	"
Hunt, Barbara J., 41/341 Bowen Tce, New Farm, Qld.	98.60	"	"
Hunt, Hamlyn R., "North Toolburra", Warwick, Qld.	98.60	"	"
Hunter, Alma C., 37 Taro St, Blakehurst, N.S.W.	14.60	"	"
Hutchinson, Ian K., 9 Plucks Rd, Arana Hills, Qld.	23.80	"	"
Irwin, William, 6 Doveton St, Ballarat	129.60	"	"
Jackson, Eileen E., 39/21 Johnson St, Chatswood, N.S.W.	98.40	"	30.4.83
Johnson, June E., 17 Towerhill Rd, Frankston	70.80	"	18.8.83

Unclaimed Moneys Act 1962

Register of Unclaimed Moneys held by the—

<i>Name of Owner on Books and Last Known Address</i>	<i>Total Amount Due to Owner</i>	<i>Description of Unclaimed Money</i>	<i>Date when Amount first became Payable</i>
\$			
AMATIL LIMITED— <i>continued</i>			
Johnston, Barbara J., More Cottage, 10 Park Lane, Reigate, Surrey, England	105.09	Cheque	15.2.84
Johnston, Roderick S. S., More Cottage, Park Lane, Reigate, Surrey, England	64.26	"	18.8.83
Knott, Roy M., c/o Coastal Stores, Post Office, Cape Rodney, P.N.G.	41.89	"	15.2.84
Knox, Stella L., c/o P.O. Box 121, Fremantle, W.A.	10.01	"	"
Kootong Holdings Pty. Ltd., 8th Floor, 160 Queen St, Melbourne	99.00	"	"
Lackey 3rd, Frank D., 81 Farm St, Dover, Massachusetts, 02030 U.S.A.	93.50	"	"
Leslie, Keith W., 32 Westbourne Ave, Drummoyne, N.S.W.	14.40	"	18.8.83
Lindsay, Jeanne M., 8 Queen St, North Ward, Townsville, Qld.	19.50	"	30.4.83
Little, Christopher R., c/o Lloyds Bank Ltd. Uckfield, Sussex, England	72.25	"	18.8.83
Littlejohn, Helen M., c/o Blake & Riggall, B.H.P. House, 140 William St, Melbourne	32.50	"	30.4.83
Lowe, Roslyn D., Manaleuka Raby Rd, Minto, N.S.W.	28.56	"	18.8.83
Luker, Annie L. (estate of), c/o W. Luker, 28 Beach Rd, Collaroy, N.S.W.	68.86	"	15.2.84
MacDonald, Eustace J. (estate of), c/o Robinson Cox, G.P.O. Box P1214, Perth, W.A.	252.00	"	18.8.83
Madden, Mary, 21 Gordon Gve, South Yarra	26.40	"	15.2.84
Marshall, Albert C. (estate of), c/o Jaques & Pawson, P.O. Box 842, Geelong	26.40	"	"
Martin, Yvonne, 4 Lea St, Croydon, N.S.W.	27.93	"	18.8.83
Matile, Eric M., 23 Baracchi Cres, Giralang, A.C.T.	10.00	"	"
McCann, Edeline D. H., 54 Canterbury Tce, East Victoria Park, W.A.	41.14	"	15.2.84
McCappin, Sallyanne C., 5 Duke St, Subiaco, W.A.	67.40	"	18.8.83
McGrath, Joan, 77 Alexander St, Greymouth, N.Z.	23.75	"	15.2.84
McGregor, Brigid M., Mount Linton Ohai, Southland, N.Z.	32.72	"	18.8.83
McManamey, William J., c/o Hardings, 4 Bridge St, Sydney, N.S.W.	49.98	"	"
Middleton, Ian D., 5 Lambert St, Ermington, N.S.W.	21.60	"	"
Munro, William A. (estate of), c/o A. C. Morrison & Richards, 18 Bon-Accord Cres, Aberdeen AB9 1XL, Scotland, U.K.	41.77	"	"
Murray, Stephen B., 25 Bowfell Rd, London W6, England	168.30	"	15.2.84
Naple, Alexander E., P.O. Box 3, Rose Bay, N.S.W.	22.00	"	18.8.83
Naughton, Claude B., P.O. Box 315, Surfers Paradise, Qld.	189.00	"	"
Newbury, Ann, 6 Shetland Ave, Marion, S.A.	127.28	"	30.4.83
North, Peter M., 29/147 March St, Richmond, N.S.W.	11.00	"	15.2.84
O'Brien, Mabel V. (estate of), c/o National Trustees Exec. & Agency Co. of Australasia Ltd, G.P.O. Box 2819AA, Melbourne	17.20	"	18.8.83
Orchard-Lisle, Rhona, Old Gaylors, Westmill Nr Buntingford, Herts SG9 9LB, England	41.44	"	31.10.83
Partridge, Marjorie J. (estate of), c/o Breeze & Wyles, 263 Green Lanes, Palmers Green, London N13 4XE, England	58.72	"	15.2.84
Peacock, John K., Unit 6, 10 Alexandra Rd, Ringwood East	134.80	"	18.8.83
Redford, Arthur L. and Marion, 3 Jamner St, Chapel Hill, Qld.	100.00	"	"
Rheuben, Peter A., Smith, Leonard R. and McLean, Allan I., c/o Rydalmer Wholesalers Pty. Ltd., 14A Clyde St, Rydalmer, N.S.W.	56.71	"	31.10.83
Rhodes, Ronald D., 6 Waiatarua Rd, Auckland 5, N.Z.	20.94	"	15.2.84
Riarda Pty. Ltd., 1 Vista Ave, Balgowlah Heights, N.S.W.	1109.04	"	29.7.83
Richards, Ronald H., 160 Castlereagh St, Sydney, N.S.W.	131.88	"	18.8.83
Roberts, Francis H., 716 Gladstone Rd, Gisborne, N.Z.	55.35	"	15.2.84
Rutherford, Arthur A., P.O. Box 3, Bargo, N.S.W.	30.24	"	18.8.83

Unclaimed Moneys Act 1962

Register of Unclaimed Moneys held by the—

<i>Name of Owner on Books and Last Known Address</i>	<i>Total Amount Due to Owner</i>	<i>Description of Unclaimed Money</i>	<i>Date when Amount first became Payable</i>
\$			
AMATIL LIMITED— <i>continued</i>			
Ryan, Betty I., P.O. Box 79, Balwyn North	57.60	Cheque	18.3.83
Ryan, Patricia, 6 Astor Crt, cnr Wharf & Leichhardt Sts, Brisbane, Qld.	94.08	"	"
Sanders, Herbert B., 45 Palace Rd, Llandaff Cardiff, Wales	121.36	"	15.2.84
Sanderson, Charles J. and John A., Survivors in Joint A/C with Kenneth J. (dec.), 16 Hampden Rd, Russell Lea, N.S.W.	140.82	"	31.10.83
Sarroff, John, Suite 1108, 11th Floor, 67 Castlereagh St, Sydney, N.S.W.	14.40	"	18.8.83
Saunders, Enid A. E., 3-5 Ocean Ave, Edgecliff, N.S.W.	97.30	"	"
Shields, Eileen, 9 Woodbine Rd, Black Rock, Co. Dublin Eire	43.96	"	"
Simmons, Frank L., 10 Horton St, Marrickville, N.S.W.	21.63	"	"
Simonsen, Harold R., 10 Norman Ave, San Souci, N.S.W.	30.24	"	"
Skurr, John E. (estate of), c/o Wynn Williams & Co, P.O. Box 22,205, Christchurch, N.Z.	74.43	"	"
Smith, Harold S., 1/340 Mt Eden Rd, Auckland 3, N.Z.	53.55	"	"
Smith, Marie, 29 Wybalena Rd, Hunters Hill, N.S.W.	47.04	"	"
Smith, Stella M. (estate of), c/o E. J. Smith, Lousley & Smith, P.O. Box 193, Dunedin, N.Z.	26.93	"	15.2.84
Speight, Helen L., 20 Murray Rd, Beecroft, N.S.W.	151.20	"	18.8.83
Stacey, Ruth L., 14/159 Balaclava Rd, Willandra Village, Marsfield, N.S.W.	70.50	"	7.3.83
Stevenson, Evelyn E. M., 40 South Park, Sevenoaks, Kent, England	58.53	"	15.2.84
Stewart, William R., 20 Shortland St, Christchurch, N.Z.	11.49	"	30.4.83
Stretch, Herbert W., 9 Central Tce, Alicetown L H, N.Z.	30.60	"	18.8.83
Summers, Horace B., 25 Birdwood Pde, Dalkeith Nedlands, W.A.	169.40	"	"
Sumner, Michael G. C. (estate of), c/o McGuren Allen & Holt, Level 42, MLC Centre, Martin Place, Sydney, N.S.W.	453.60	"	"
Suter, Charles K. (estate of), c/o G.P.O. Box 145, Sydney, N.S.W.	37.80	"	"
Sutton, Elaine J., 132 Cowper St, Dickson, A.C.T.	75.60	"	"
Taverner, Lewin G. M. (estate of), c/o Goodman Taylor & Co., P.O. Box 190, Marton, N.Z.	240.62	"	"
Terry, Leonard M., Hounville, Tas.	264.60	"	"
Thomas, Herbert F. M., 3 Chepstow Crt, Chepstow Crescent, London W11 3ED, England	130.64	"	"
Survivor, Jennis E. T., In Joint A/C with Leslie George Thomas (estate of), 72 Blackborne Rd, Dagenham, Essex, England	10.28	"	15.2.84
Tierney, Angelena G., 16 South Valley Rd, Highton	79.20	"	"
Tout, Katherine E., 33 Golf Links Rd, Buderim, Qld.	253.44	"	"
Tralian Pty. Ltd., P.O. Box 121, Broken Hill, N.S.W.	329.49	"	18.8.83
Troughton, Veronica, 4 Stanhope Mews South, Gloucester Rd, London SW7, England	12.71	"	31.10.83
Turnbull, Hilda J., 5 Denvegan House, Christchurch Park, Sutton Surrey SM2 5UA, England	83.89	"	18.8.83
Vance, Robert B. and Skinner, Keith A. R., c/o Wilson Bishop Bowes & Croig, 271 William St, Melbourne	23.76	"	15.2.84
Walter, Kenneth G., 4 Auvergne Ave, New Town, Tas.	412.65	"	18.8.83
Warner, Edwin A., 103 Springvale Rd, Killara, N.S.W.	971.30	"	15.2.84
Welford, Muriel J. M., 9505 Midwood Rd, Silver Spring, Maryland, 20910, U.S.A.	37.68	"	"
West, Norman G. N., 27 Eden Ave, Turrumurra, N.S.W.	24.70	"	18.8.83
White, Blanche (estate of), c/o C. J. Diamond, 206 Commercial Rd, Prahran	228.69	"	"

Unclaimed Moneys Act 1962

Register of Unclaimed Moneys held by the—

<i>Name of Owner on Books and Last Known Address</i>	<i>Total Amount Due to Owner</i>	<i>Description of Unclaimed Money</i>	<i>Date when Amount first became Payable</i>
\$			
AMATIL LIMITED—continued			
White, Charles E. and Alma M., 15 Currawong Ave, Palm Beach, N.S.W.	68.04	Cheque	18.3.83
Whitehouse, Melanie A., c/o Barclays Bank Ltd., 81 Fleet St, London EC4, England	42.48	"	"
Wilson, Donald and Rheuben, Peter and Smith, Leonard, c/o Rydalmere Wholesalers Pty. Ltd., 14A Clyde St, Rydalmere, N.S.W.	28.80	"	"
Worrall, Arthur E. and Gwendoline E. O., 76 Mann St, Numbucca Heads, N.S.W.	44.80	"	"
Wrench, Peter C. C., 33 Upper Cliff Ave, Northbridge, N.S.W.	37.80	"	"
Wrigley, Natalie B., c/o Post Office, Upper Hutt, N.Z.	203.66	"	"
Wyatt, Donald S., P.O. Box 149, Port Lincoln, S.A.	12.00	"	"
Yerbury, Coral E., 73 General Holmes Dve, Brighton Le Sands, N.S.W. 7688	44.80	"	"
A. J. BARCLEY PTY. LTD.			
Verhoven, J., 2/132 Mitford St, Elwood	74.00	Security	—12.83
MacCrury, L., 25 Chanak St, Malvern	373.00	"	"
Carter, W., 5/18 Orange Gve, East St. Kilda	100.00	"	"
Talbot, I., 6/27 Gourlay St, East St. Kilda	75.00	"	"
Fry, E., 7/27 Gourlay St, East St. Kilda	55.70	"	"
Duncan, J., 1/34 Longmore St, St. Kilda	114.60	"	"
Brown, 1/38 Howitt St, Hawksburn	90.30	"	"
Czarski, 8/34 Carlisle St, St. Kilda	19.44	"	"
Nikulaidis, A., 8/312 Beaconsfield Pde, Albert Park	87.29	"	"
O'Neill, G. (estate of), 4/27 Gourlay St, East St. Kilda 7444	230.00	"	"
UNION INVESTMENT COMPANY LIMITED			
Fleay, A. E. B., Wickepin, W.A.	11.40	Dividend	26.10.83
Fleay, E. W., W. W., E. H. York, W.A. 7442	22.80	"	"
VACC HOLDINGS LIMITED			
Bradley, David G., P.O. Box 167, Willoughby, N.S.W.	15.40	Dividend	26.4.83
Broughan, Margaret A., 261 Glenferrie Rd, Malvern	15.40	"	"
Chong, Cheng C., 7/5 Stanley St, Randwick, N.S.W.	15.40	"	"
Cottrell, John S., G.P.O. Box E 269, Perth, W.A.	30.89	"	"
Robinson, Sidney H., P.O. Box 45, Avalon Beach, N.S.W. 7443	20.98	"	"
THE CORPORATE CLEARING HOUSE PTY. LTD.			
Anderson, Graham Harris, 27 Bentley Road, Stoneville, W.A.	760.90	Return	6.6.83
Whitney, Ormond Andrew, Chamliir Street, Berrigan, N.S.W.	221.39	Return	28.6.83
Higgs, Glenda Jean, 100 Grange Road, Glenhantly	164.40	Return	"
Bracher, Peter Barrington, 16 Urquhardt Street, Parap, N.T.	94.58	Return	29.6.83
Smith, Raymond Maxwell, Lot 1, Brinsmead Lane, Leopold	193.00	Return	29.6.83
Reddy, William E., 18 Granford Ave, St. Ives, N.S.W. 7441	201.15	Return	29.6.83

Unclaimed Moneys Act 1962

Register of Unclaimed Moneys held by the—

<i>Name of Owner on Books and Last Known Address</i>	<i>Total Amount Due to Owner</i>	<i>Description of Unclaimed Money</i>	<i>Date when Amount first became Payable</i>
\$			
DUNLOP OLYMPIC LIMITED			
Adams, Mary L., P.O. Box 411, Bairnsdale	15.00	Cheque	9.12.83
Alexander, Janet, 67 Old Orchard Dve, South Wantirna	11.00	"	"
Allison, James J., Greton, No. 2 R.D., Rangiora, N.Z.	46.75	"	"
De Pledge, Thomas D., Alston, Yanrey Station, Carnarvon, W.A.	12.15	"	"
Arbuthnot, James D., c/o Fimco, Frances Creek, N.T.	15.00	"	"
Associate Developments Pty. Ltd., 1306 Hay St, Perth, W.A.	20.00	"	"
Atkin, Edith M., 730 Pacific Hwy, Gordon, N.S.W.	45.90	"	"
Bachtin, Maria P., 10 Scott St, Croydon, N.S.W.	61.30	"	"
Baird, John H., 28 Woolwich Rd, Hunters Hill, N.S.W.	217.00	"	"
Bakewell, Ann-Marie, Flat 3, 131 Young St, Neutral Bay, N.S.W.	18.00	"	"
Balmain, Nanette E., c/o Allens Private Hotel, 28 Lower Wycombe Rd, Neutral Bay, N.S.W.	47.40	"	"
Bannister, Margaret (Sr), 2/32 Orient Ave, Mitcham	22.00	"	"
Barber, Janet M., 40 Princes St, Ryde, N.S.W.	18.40	"	"
Barnes, June N., 66 Bancroft Ave, Roseville, N.S.W.	50.00	"	"
Bartu, Friedrich A., 14 Harley St, Highgate, W.A.	15.00	"	"
Beck, Frederick D., 254 Bay St, Brighton	55.20	"	"
Bell, Stephen A., Box 9514, Newmarket, Auckland, N.Z.	19.12	"	"
Benson, Richard E., 20 Mark St, Hunters Hill, N.S.W.	50.00	"	"
Bentley, Charles D., 182A Lawley St, Yokine, W.A.	23.70	"	"
Bentley, Peter M. J., 4/10 Cecil St, Ashfield, N.S.W.	15.00	"	"
Bird, Marcia M., 10 Victoria St, Antanton Hill, Townsville, Qld.	40.25	"	"
Bladen, Alfred G., c/o R. M. Bladen and Company, P.O. Box 422, Campbelltown, N.S.W.	152.80	"	"
Lempriere, Anne L., Blair, P.O. Box 486, Benalla	56.65	"	"
Bloom, Maurice and Luba, 2/442 Dandenong Rd, Caulfield	11.00	"	"
Boehm, Kenneth A., Box 332, Port Moresby, PNG	17.76	"	"
Boyd, Jessie A., c/o ANZ Executors and Trustee Co. Ltd., G.P.O. Box 389D, Melbourne	133.90	"	"
Brandham, Vera M., 20 The Quarterdeck, Tweed Heads, N.S.W.	25.00	"	"
British Law Executor and Trustee Company (Guernsey) Limited, a/c GW1066, Tower Hill House, Bordage St, Peter Port, Guernsey, CI	13.82	"	"
Britto, Julius and Maria L., 189 Victoria St, Ashfield, N.S.W.	37.50	"	"
Brown, Janice, 99 Skene St, Newtown	11.00	"	"
Bunnett, Thelma M., c/o Arthur Phillips and Just, P.O. Box 261, Collins St, Post Office, Melbourne	128.95	"	"
Burgess, Helene B. (estate of), c/o V. M. Lamb, P.O. Box 159, Geelong	23.85	"	"
Byrne, Margaret M., 3/24 Parnell St, Elsternwick	96.00	"	"
Calvert, James L., Myanbah, Uralla, N.S.W.	125.00	"	"
Carlyle, Dawn A., 19 Sunrise Blvd, Surfers Paradise, Qld.	15.00	"	"
Ceylon, Charles, 9/2A Penkivil St, Bondi, N.S.W.	45.00	"	"
Chong, Chu Fong, 11 Brentleigh Crt, South Vermont	100.00	"	"
Chong, Chu Fong, Statewide Permanent Building Society, a/c 10127744, Mahoney Rd, Forest Hill	"	"	"
Clancy, Adelaide F. (estate of), c/o Public Trust Office, P.O. Box 660, Newcastle, N.S.W.	18.75	"	"
Clark, John G. (estate of), B. J. Clark, P.O. Box 555, Launceston, Tas.	33.00	"	"
Clasper, Ella, 449 Geelong Rd, West Footscray	10.80	"	"
Cochrane, Shirley, 93 Queen St, Westfort, N.Z.	42.07	"	"
Coffey, Michael C. and Margaret, 49 Glengarriff Dve, Floreat Park, W.A.	33.00	"	"

Unclaimed Moneys Act 1962

Register of Unclaimed Moneys held by the—

<i>Name of Owner on Books and Last Known Address</i>	<i>Total Amount Due to Owner</i>	<i>Description of Unclaimed Money</i>	<i>Date when Amount first became Payable</i>
\$			
DUNLOP OLYMPIC LIMITED— <i>continued</i>			
Colditz, Paul B., 3/8 Pitt St, Randwick, N.S.W.	15.00	Cheque	9.12.83
Colquhoun, Helen L., P.O. Box 71, South Yarra	20.70	"	"
Condon, Gweneth D., 20 Monaro Rd, Kooyong	14.55	"	"
Corrigan, John L., 206 Victoria St, Ballarat	10.35	"	"
Coutts, Lesley A., Cooma, Mt. Beckworth via Creswick	137.50	"	"
Cowburn, Catherine, Cherwell House, Mill End, Kidlington, Oxford, England	12.75	"	"
Cox, Peter H., 20 Calbrina Rd, Northbridge, N.S.W.	12.00	"	"
Crane, Peter C., 48 Edwin St, Croydon, N.S.W.	17.55	"	"
Cranwell, Nellie R., c/o R. J. Cranwell, 61 Quinlan Ave, St. Marys, S.A.	50.00	"	"
Creer, Dahlis V., 14 Geelway Pl, Deakin, ACT	18.00	"	"
Cudmore, James M., 29 Burlington St, Walkerville, S.A.	36.70	"	"
Culley, Kelvyn M., 17 Wattle Tce, Plympton Park, S.A.	18.75	"	"
Currie, Elizabeth A., c/o Lionel R. Stewart Brown, c/o P.O. Box 627, Chatswood, N.S.W.	60.00	"	"
Currie, William R., 43 Apex Ave, Moorabbin	19.80	"	"
Dawson, Fiona D., 39 Liverpool St, Paddington, N.S.W.	36.70	"	"
Dharmalingam, Saunthari, Juliet, c/o 21 Crystal Cres, Wyong, N.S.W.	31.50	"	"
Dixon, Michael A., 20 Longwood Rd, Stirling, S.A.	15.00	"	"
Doherty, Jack, Flat 6, 444 Canterbury Rd, Nunawading	26.75	"	"
Dorsel Holdings Pty. Ltd., 278 Old Northern Rd, Castle Hill, N.S.W.	91.70	"	"
Downes, Ruth J., 16 Heights Cres, Middle Cove, N.S.W.	15.00	"	"
Duncan, James and MacDermott, Charles F., c/o C. F. MacDermott, 15 Fitzherbert Tce, Wellington, N.Z.	15.30	"	"
Dupont, G. E. A., and Y. E., and R. A., and L., De Desinfectants Laboratoires, Marocain Rue Medecin Major, Ayrand Casablanca, Moroc	81.48	"	"
Earls, Mary D. (estate of), c/o 310 Blaxland Rd, Ryde, N.S.W.	12.30	"	"
Edmonds, Keith M., 161 Balcombe Rd, Mentone	11.85	"	"
Edwards, Janice, 43 Wilson St, Broken Hill, N.S.W.	16.50	"	"
Evans, Irene M., c/o John I. Sullivan, Chisholm and Associates, P.O. Box 35, Caulfield South	29.50	"	"
Eves, Lola C., P.O. Box 279, Forster, N.S.W.	33.75	"	"
Field, Prudence V., 5 Walker St, Doncaster	18.40	"	"
Foletta, Henry C., Woodside, Bonds Rd, Lower Plenty	15.00	"	"
Foletta, Judith A., 5/86 Cromwell Rd, South Yarra	35.00	"	"
Francis, Barbara M., 24 Shamrock St, South Launceston, Tas.	11.55	"	"
Gainger, Cecilia C., 42 Grace St, Melton South	38.50	"	"
Gala Holdings Pty. Limited, 96 Flinders St, Melbourne	33.00	"	"
Galvin, Robert, 107 Moree St, Stafford, Qld	25.00	"	"
Gates, Marion D., 29 Fitzwilliam St, Kew	12.30	"	"
Gelman, Colin, 97 Rose St, Fitzroy	13.75	"	"
Gill, Veronica M., 12 Drummond St, Blackburn South	40.50	"	"
Glase, Rene, 2/12 Golf Ave, Mona Vale, N.S.W.	41.25	"	"
Glisson, Jann, 54 St. Elmo Pde, Kingsgrove, N.S.W.	16.20	"	"
Goldman, Sarah, 28 Ravensdale Rd, Stamford Hill, London N 16, U.K.	15.94	"	"
Goldsmith, Gerald, P.O. Box M3, Sydney Mail Exchange, Sydney, N.S.W.	75.00	"	"
Grainger, Henry T., 15 Truganini St, Burnie, Tas	13.00	"	"

Unclaimed Moneys Act 1962

Register of Unclaimed Moneys held by the—

<i>Name of Owner on Books and Last Known Address</i>	<i>Total Amount Due to Owner</i>	<i>Description of Unclaimed Money</i>	<i>Date when first became Payable</i>
\$			
DUNLOP OLYMPIC LIMITED— <i>continued</i>			
Lang, Diana, 11 Tintern Ave, Toorak	37.50	Cheque	9.12.83
Lation Enterprises Proprietary Limited, 10 Chatfield Ave, Balwyn	25.00	"	"
Lawless, Burnett R., Boonbyjan, Goomeri, Qld	69.00	"	"
Laxton, Ernest G., 186-188 Smith St, Collingwood	50.45	"	"
Lee, Teong K., 91 Nicholson St, Carlton	45.00	"	"
Legge, Jean G., 18 Parriwi Rd, Mosman, N.S.W.	50.10	"	"
Lenko, Alexander, 4 Montgomery St, East Brighton	11.00	"	"
Leone, Priscilla M., 74 Fordham Ave, Camberwell	118.50	"	"
Lewis, Vera B., 29 Pasadena St, Kogarah, N.S.W.	14.00	"	"
Livesley, Joyce H., 3 Pratten Ave, Ryde, N.S.W.	21.75	"	"
Lloyd, Stewart C., Officers Mess, Army School of Transport, Puckapunyal	11.00	"	"
Lockhart, Basil J., 40 North St, Devonport, Tas.	20.20	"	"
MacIntosh, William K., P.O. Box 34, Blackbutt, Qld	97.50	"	"
Madill, Floyd D. J. and Judith M., P.O. Box 666, Prosperine, Qld	11.85	"	"
Mann, Carolyn S., 16 Shaw St, Springvale South	21.00	"	"
Marshall, Valmai, 183 Evans St, Rozelle, N.S.W.	36.70	"	"
Mason, Lorna E., 8 Middle Rd, Camberwell	101.25	"	"
McAdam, George M., Unit One, 41 Alma Rd, St. Kilda	21.75	"	"
McCarthy, Charles D., 9 Daniel Crt, Scarborough, Qld	10.20	"	"
McCaughlan, Allan C., 9 Mt. Sion Pl, Glenbrook, N.S.W.	11.15	"	"
McIvor, Sonia J., 85 Crystall St, Petersham, N.S.W.	27.00	"	"
McLennan, Iain A., c/o Manion McCosker, Temple Court, 75 Elizabeth St, Sydney, N.S.W.	97.80	"	"
McNeill, Marjory P., 295 Military Rd, Dover Heights, N.S.W.	30.60	"	"
Michell, Beatrice E., Unit 1, 2 Crossing St, St. Georges, S.A.	33.00	"	"
Mimosa Estates Pty. Ltd., P.O. Box 394, Double Bay, N.S.W.	145.00	"	"
Mitchell, Betty W., 36 Henderson St, Eastwood, N.S.W.	15.00	"	"
Mitchell Dulcie, c/o Rev. James Osborne Mitchell, 21 Handon St, Mansfield, Qld	30.60	"	"
Mitchell, William B., Post Office Box 87, Rose Bay, N.S.W.	12.45	"	"
Moeller, Charles H., P.O. Box 624, Surfers Paradise, Qld	18.75	"	"
Moloney, Peter J., 659 Flinders St, Extension, Melbourne	23.55	"	"
Moore, Alan U., 35 York St, Dundas, N.S.W.	11.00	"	"
Moses Lydal M., Albury St, Harden, N.S.W.	14.80	"	"
Mott, Margaret J., 13 Atkinson St, Templestowe	50.30	"	"
Muirhead, Donald R., c/o Post Office, Bluewater, Qld	10.00	"	"
Mulmore Investments Pty. Ltd., 26 White St, Lilyfield, N.S.W.	100.00	"	"
Neilson, Nancy (estate of), 4 Fraser Ct, Whyalla Stuart, S.A.	15.00	"	"
O'Brien, Danny J., 10 Lambourne St, Surrey Hills	15.00	"	"
O'Connor, Brian J., 29 Churchill Cres., Cammeray, N.S.W.	100.00	"	"
Osborne, Beryl B. I., 24/282 New South Head Rd, Edgecliff N.S.W.	470.15	"	"
Owen, Mavis M., and Edward D., 33 King St, St. Marys, N.S.W.	11.85	"	"
Palmer, Jan L., 1/71 Bruce Ave., Belfield, N.S.W.	13.30	"	"
Parker, Ida, G.P.O. Box 135, Sydney, N.S.W.	54.45	"	"
Patrick, James W. A., P.O. Box 206, Pymble, N.S.W.	13.50	"	"
Paul, Geoffrey, 185 Hope St, Bathurst, N.S.W.	18.00	"	"
Persson, Conrad L., 2 Glenrock Ave, East Wahroonga, N.S.W.	18.75	"	"
Pert, Rowan A., c/o Markay Veterinary Surgery, 58 Nebo Road, Mackay Qld	12.90	"	"
Phillips, Yvonne S., P.O. Box, 183, Manjimup, W.A.	15.15	"	"

Unclaimed Moneys Act 1962

Register of Unclaimed Moneys held by the—

<i>Name of Owner on Books and Last Known Address</i>	<i>Total Amount Due to Owner</i>	<i>Description of Unclaimed Money</i>	<i>Date when Amount first became Payable</i>
\$			
DUNLOP OLYMPIC LIMITED— <i>continued</i>			
Pilgrim, Athole J. (estate of), c/o Public Trust Office, Trustee House, 444 Queen St, Brisbane, Qld	11.85	Cheque	9.12.83
Pillars, Winifred, 1047 Malvern Road, Toorak	10.00	"	"
Podbury, Murray B., 5 Vanessa Crt, Frankston	80.10	"	"
Pring, Douglas B. and Veronica, 19 Geisel St, Dalby, Qld	100.00	"	"
Pritchard, Isobel, Lot 13, Kerr St, Ballina, N.S.W.	11.85	"	"
Probert, Barry J., 3 Corinda Ave, Kensington Park, S.A.	18.40	"	"
Pura, Lionel M., Unit 1/171 Wattle Valley Rd, Camberwell	22.50	"	"
Purchas, Elizabeth F., 8 Mackenzie St, Bondi Junction, N.S.W.	15.75	"	"
Purdy Associates Pty. Ltd., P.O. Box 89, West Perth, W.A.	50.45	"	"
Quah, Peng C., 11A Lawanna Dve, Lower Templestowe	610.00	"	"
Robert, Winifred E., 16 Stanhope Gve, Camberwell	37.35	"	"
Robertson, Veronica A., 140 Pentecost Ave, Turramurra, N.S.W.	45.90	"	"
Robinson, John C., P.O. Box 1213, Kota Kinabalu, Sabah, East Malaysia	13.60	"	"
Davies-Roe, Paul E., 1 Orchard St, Thornleigh, N.S.W.	18.00	"	"
Roffman, Louis, Riverside, County of Riverside, California, U.S.A.	10.07	"	"
Roget, Mabel E. (estate of), c/o 16 Glassford St, Armadale	25.65	"	"
Rosenberg, Keith J., Flat 24, Burnie Crt, Lyons, A.C.T.	33.00	"	"
Runnel, Valdu, 337 Montague Rd, Para Vista, S.A.	67.90	"	"
Scannell, Michael F., 25 Elsmere St, Kensington, N.S.W.	165.40	"	"
Schmidt, Harry P., 68 Virginia St, Mt. Waverley	13.95	"	"
Scott, Peter H., 216 Spit Rd, Mosman, N.S.W.	30.00	"	"
Sear, Duncombe, 12 Ashfield Crt, Margaret St, Sandy Bay, Tas.	33.75	"	"
Shearer, Peter D., 257 Hawkin Dve, St. Lucia, Qld.	15.00	"	"
Shepherd, Alwyn A., 177 Ruahine St, Palmerston North, N.Z.	15.30	"	"
Silcock, John H., c/o Bank of New South Wales, corner Murray and William Sts, Perth, W.A.	37.50	"	"
Sleat, Ian L D., Flat 4, The Grange, 10 Grange Hill, London, SE 25, U.K.	17.34	"	"
Smith, June H., 5 Narveno Crt, Hawthorn	26.30	"	"
Smith, Robert W. and Curry, Roberta, 42 Ducat St, Tweed Heads, N.S.W.	242.10	"	"
South Parade Pty. Limited, P.O. Box 164, Concord, N.S.W.	275.00	"	"
Stoney, Elizabeth A., 5 Moore St, Hawthorn	150.70	"	"
Street, Dermont C., 34 Muritai Rd, Takapuna, Auckland 9, N.Z.	15.43	"	"
Stubbs, John R., 3 Power St, St. Marys, N.S.W.	11.85	"	"
Summers, Frank H., 37 Elmo Ave, Westbourne Park, S.A.	16.95	"	"
Swindell, Yvonne V. M., c/o R. M. Black & Assoc., G.P.O. Box L888, Perth, W.A.	43.15	"	"
Syme, Heather Y., 11 Bulleen Rd, North Balwyn	15.40	"	"
Symons, Milton C., Bank of New South Wales, Wentworth Street Branch, Wentworth Hotel, Sydney, N.S.W.	11.25	"	"
Tan, Dr Tiong C., P.O. Box 5855, Boroko, Port Moresby, N.G.	63.75	"	"
Thompson, Marjorie B., 11 Quinton Rd, Manly, N.S.W.	65.10	"	"
Turrarport Pty. Ltd., c/o John McDowell, 60 Warrangi St, Turramurra, N.S.W.	141.70	"	"
Vautin, John S., 10 Balmaringa Ave, Turramurra, N.S.W.	18.05	"	"
Walker, Dorothy E. (estate of), c/o Shirley D. Minchin and Ingus, D. G., 3 Manningtree Rd, Hawthorn	60.50	"	"

Unclaimed Moneys Act 1962

Register of Unclaimed Moneys held by the—

<i>Name of Owner on Books and Last Known Address</i>	<i>Total Amount Due to Owner</i>	<i>Description of Unclaimed Money</i>	<i>Date when Amount first became Payable</i>
--	--	---	--

\$

DUNLOP OLYMPIC LIMITED—continued

Walker, Edward G., 183 Station St, Fairfield	65.00	Cheque	9.12.83
Waterfield, Glen, 41 Surrey Cres, Grey Lynn, Auckland, N.Z.	12.75	"	"
Waters, Paula N., "Noojee", Walla Walla, N.S.W.	18.75	"	"
Way, Lewis M. (estate of), c/o Northcote & Co., P.O. Box 548, Copthall Cl, London, EC2P 2JJ, U.K.	44.37	"	"
Weeks, Forster B., Tanga House, 5 Princes Rd, Tamavua, Suva, Fiji	52.50	"	"
Weeks, Roger B., 7th Floor, Kayamally Building, 22 Queens Rd, Central, Hong Kong	31.50	"	"
Wells, Antony D. and Burley, Edmund A., 13 Charlbury Way, Eden Hill, W.A.	27.00	"	"
West Aust Tee Exor & Agcy Co. Ltd. & Emily E. Klein & Rita A. Honner & Clement W. Honner, 135 St. Georges Tce, Perth	165.00	"	"
Whittle, Margaret F. (estate of), c/o J. W. Whittle, 50 Tennyson St, Kew	20.00	"	"
Wild, Dr John P., 3 Strathfield Ave, Strathfield, N.S.W.	18.00	"	"
Williams, Robert P., 362 Commercial Rd, Yarram	12.10	"	"
Williamson, Elizabeth M., 29 Ebor Ave, Mile End, S.A.	30.00	"	"
Willson, Beverley I., P.O. Box 253, Gisborne, N.Z.	76.50	"	"
Wise, Robert E., 13 Wharf Rd, Longueville, N.S.W.	86.20	"	"
Wiseman, Dr Michael A., 22 Kendal Crt, Shoot-Up-Hill, NW2, England	234.68	"	"
Zimmerman, Stanley, 6 Turnstone St, Doncaster East 7733	25.00	"	"

G.U.D. HOLDINGS LIMITED

Boyd, Stephen J., 11 John St, Ringwood	11.20	Dividend	25.11.83
Poltrock, Amy B., 22 Young St, Balaclava	119.10	"	"
Rudd, Phillip J. and Helen, 355 Swann Rd, St. Lucia, Qld	27.00	"	"
Weber, Caroline E., 14/26 Highended Rd, East St. Kilda	67.50	"	"
Scott, Malcolm C., 65 Lawrence Cres, Manurewa, Auckland, N.Z. 7596	15.64	"	"

A.M.P. FIRE AND GENERAL INSURANCE COMPANY LIMITED

Clark, Robert G., c/o Thermoflare Pty. Ltd., 6 Walter St, Moorabbin	117.41	Policy	17.6.83
Hug, Bernard W. and Margaret A., 12 Martell St, Broadmeadows	100.00	Claim	24.10.83
Jay, A. R., 21 Wellington St, Richmond	42.98	Policy	27.5.83
Lopes, N. T., 51 Leopold St, South Yarra	10.60	"	25.3.85
Mitchell, Shane J., 16 Viewhill Cres, Eltham	52.12	Commission	2.8.83
Monger, K. S. and J. A., 31 Griffith Rd, Upwey	18.78	Policy	8.4.83
Nehill, Frances E., 658 Station St, North Carlton	28.00	"	11.8.83
Old, K., 4 Marion Ave, Mooroolbark	81.18	"	29.4.83
Olle, L. F. and G. D., 7 Hilton St, Mount Waverley	126.23	"	7.9.83
Roach, Janet M., Room 1, Ground Floor, 354 Tooronga Rd, East Hawthorn	31.95	"	8.3.83
Sheehan, Terrance J., c/o ANZ Bank, 210 Summer St, Orange, N.S.W.	48.70	"	28.4.83
Scullino, N., 34 Lantana Ave, Thomastown	20.80	"	28.3.83
Taylor, J. M., 33 Wave Ave, Mount Waverley	109.61	"	21.5.84
Trovarelli, Anthony J., 53 Tyrone St, Werribee	132.68	"	31.3.83
Williams, L. L., 3 Hilton St, Clifton Hill	110.57	"	8.9.83
Zaffino, Frank, 3/14 Fulham Rd, Alphington	11.07	"	25.3.83

Unclaimed Moneys Act 1962

Register of Unclaimed Moneys held by the—

<i>Name of Owner on Books and Last Known Address</i>	<i>Total Amount Due to Owner</i>	<i>Description of Unclaimed Money</i>	<i>Date when Amount first became Payable</i>
\$			
CRA GROUP SHARE REGISTRY			
Adams, Hilary M., 10 Brodrick St, Karrinyup, W.A.	26.46	Dividend	5.5.83
Allen, Barry, 1 Tecoma Rd, Risdon Vale, Tas.	27.00	"	"
Anderson, Keith D. (estate of), c/o W. K. Anderson, 33 Chapel St, St. Kilda	48.33	"	"
Annandale-James, John A., and Patricia E., 5 Renwick St, South Perth, W.A.	28.68	"	"
Archer, Ian M., c/o E. W. Tod, P.O. Box 18, Tumut, N.S.W.	57.96	"	"
Arthurson, Susan G., Flat 7, 47 Elizabeth St, Norwood, S.A.	22.50	"	"
Ash, Donald H., 18 Kokoda Ave, Wahroonga, N.S.W.	17.60	"	"
Aston, Frank and Smith, Henry J., and Ockerby, William T., 93 Simpson St, Mt. Isa, Qld.	150.00	"	"
Audoa, Eve L., c/o University of Papua New Guinea, P.O. Box 4694, Port Moresby, P.N.G.	10.43	"	"
Austin, Mary M., 12 Humphries Rd, Frankston	45.19	"	"
Barber, Irene A., "Lunesdale", 2 Laburnum Dve, Fulwood Preston, Lancs, U.K.	12.08	"	"
Barbour, George R., Bolesworth Castle, Tattenhall, Chester, U.K.	143.43	"	"
Baumert, Wilhelm H., and Christine B., Sturt Hwy, Lyndoch, S.A.	11.12	"	"
Bentley-Phillips, Christopher B., Suite 18, 3rd Floor, 193 Macquarie St, Sydney, N.S.W.	30.00	"	"
Bibbings, John G., 119 Chandag Rd, Keynsham, Bristol, U.K.	10.71	"	"
Boskovic, Nicola, 10 Watson Ave, Box Hill North	15.64	"	"
Bowen, Michael S., Flat 3, 13 Narong Rd, Caulfield North	15.64	"	"
Bradfield, Geoffrey G., 34 Mills St, Hampton	13.36	"	"
Breesow, Gary L., P.O. Box, Nairne, S.A.	23.88	"	"
Brice, Sheila M., Flat 11, 97 Chomley St, Windsor	10.43	"	"
Brissoni, Giuseppe, P.O. Box 1247, Boroko, P.N.G.	13.04	"	"
Britchford, Anthony G., and Daphne, P.O. Box 22, Athi River, Kenya	13.49	"	"
Brooks, Barry R., c/o McGirr & Associates Pty. Ltd., 20 Loftus St, Sydney, N.S.W.	21.73	"	"
Brown, Alan B., c/o T. A. F. McCarthy & Son, P.O. Box 59, Moss Vale, N.S.W.	44.64	"	"
Brown, Tara D. and Mitchell A., 212 Yarra St, Hawthorn	23.18	"	"
Browning, Robert, 5 Belfairs St, Robertson, Qld.	14.48	"	"
Buderus, Margaret H., c/o Papua Agencies, P.O. Box 126, Port Moresby, P.N.G.	10.43	"	"
Burke, Harry K., c/o Stearns-Roger Inc., Min. & Met. Div., P.O. Box 5888, Denver, Colo 80217, U.S.A.	52.17	"	"
Burnside, Cecilia A., 157 St. Helena Rd, Greensborough	11.04	"	"
Burt, Kenneth J., 14 Healey St, Craigieburn	14.48	"	"
Bush, Jeffrey R., 314 McLeod St, Cairns, Qld.	17.39	"	"
Butfield, George H., 124 Carrington Ave, Hurstville, N.S.W.	17.97	"	"
Byrne, Carmel M., Rose St, Moranbah, Via Mackay, Qld.	15.00	"	"
Carroll, John K., 60 South Rd, Brighton	11.20	"	"
Chambers, Esther, c/o D. Bleakley, 65 Braeside St, Wahroonga, N.S.W.	15.00	"	"
Chaytor, Anthony D. C., Marshlands, Blenheim Rd 3, N.Z.	42.84	"	"
Chee, Cedric, c/o C. & B. Chee Pty. Ltd., P.O. Box 214, Lae, P.N.G.	10.43	"	"
Christian, Charles H. (estate of), c/o Ralph W. King & Yuill, G.P.O. Box 5320, Sydney, N.S.W.	21.73	"	"
Cline, Bernard W. and Beth T., 344 Berkley Ave, East Carbon, Utah, 84520, U.S.A.	13.38	"	"

Unclaimed Moneys Act 1962

Register of Unclaimed Moneys held by the—

Name of Owner on Books and Last Known Address	Total Amount Due to Owner	Description of Unclaimed Money	Date when Amount first became Payable
\$			
CRA GROUP SHARE REGISTRY— <i>continued</i>			
Collingridge, Francis H., c/o Bank of N.S.W., Royal Exchange, Sydney, N.S.W.	23.40	Dividend	5.5.83
Cox, Daryl W. J., 405 Collins St, Melbourne	86.94	"	"
Cox, Jennifer A., 4 Emerald Rd, Belgrave	13.60	"	"
Cranford, Roland H., 20 Fifty Second St, Gulfport, Mississippi, U.S.A.	11.16	"	"
Creter, Samuel N., c/o Bechtel Wke, P.O. Box 12, Kieta, P.N.G.	10.43	"	"
Crosstrees Pty. Ltd., Unit 2, 7 Binnie St, Brighton East	31.32	"	"
Crowley, Peter R. O. (estate of), c/o Public Trustee, J. J. Bowlen Bldg, 620-7th Avenue S W, Calgary, Alberta, Canada	11.74	"	"
Currie, John B., 8 Lower Boyle St, Cremore N.S.W.	25.86	"	"
Curtis, Ross P., 11 Amos Pl, Marayong, N.S.W.	224.79	"	"
Dalziel, Dorothy, P.O. Box 40, Mt. Hagen WHD, P.N.G.	10.43	"	"
Davidson, Ronald S., P.O. Box 50E, Ballarat East	89.74	"	"
Dawson, Frederick A., Post Office, Glenella, Qld.	21.73	"	"
De'Andrade, Murillo, 6 Monaro Cres, Red Hill, A.C.T.	15.20	"	"
Deletang, Pierre R. and Claudie G., 7802 Benton St, Hurstville, Ala 35802, U.S.A.	11.22	"	"
Dellitt, Leigh-Anne, c/o Henderson and Knox, Cunningham St, Dalby, Qld.	14.48	"	"
Deloraine Holdings Pty. Ltd., c/o T. H. E. Macey, 604 Stafford Rd, Stafford, Qld.	15.00	"	"
Dentland Pty. Ltd., c/o Eric G. Morris, 762 King Georges Rd, Penshurst, N.S.W.	13.23	"	"
Dillon, John V., c/o Dept. Aboriginal and Island Affairs, Weipa South, Qld.	10.00	"	"
Donohue, Aileen M., 608 Harris St, Ultimo, N.S.W.	13.04	"	"
Downer, Jane F., 19A High St, Portsmouth, Hants, U.K.	17.39	"	"
Drane, Francis H., c/o J. E. Drane, 55/29 Gerard St, Cremorne, N.S.W.	10.01	"	"
Dunkley, Harry B., Fairmont, Devonshire, Bermuda	11.76	"	"
Earley, Betty A., 17 Matthews St, Stafford, Qld	10.43	"	"
E. G. & H. Nominees Pty. Ltd., 421 Bourke St, Melbourne	22.25	"	"
Ehrlich, Michael J. and Wright, Pamela A., P A/C Hill House, 37 Hendon Ave, Finchley, London N3, U.K.	12.75	"	"
El-Daher, Samira, c/o Embassy of Lebanon, 2 Trelawney St, Woollahra, N.S.W.	15.00	"	"
Emery, David L., Unit 3, 303 Montacute Rd, Athelstone, S.A.	10.43	"	"
Etheridge, Albert J., 7 Olive St, Malvern East	13.66	"	"
Eyre, Jane E., 31 Shawfield St, London SW3, U.K.	10.48	"	"
Fahey, Simon J., 2 Guilford St, Kensington Park, S.A.	36.30	"	"
Farrelly, Keith J., c/o J. G. Farrelly, Casuarina Ave, Lae, P.N.G.	10.43	"	"
Fevere, Marianne, 199 Esplanade, Machans Beach, Cairns, Qld.	14.48	"	"
Finlay, Ronald and Jennifer, 34 Wyadra Ave, Harbord, N.S.W.	30.00	"	"
Fisher, Richard W., c/o Lloyds Bank, Belgrave Road Branch, 68 Warwick Square, London SW1V 2A5, U.K.	35.70	"	"
Fitzgerald, Edward A., c/o R. A. Smith, 25 Bassett Ave, Southampton, Hants, U.K.	21.73	"	"
Foletta, Henry G., 34 St. Georges Rd, Toorak	168.82	"	"
Ford, Kenneth L. S., 231 Fernberg Rd, Paddington, Qld.	41.42	"	"
Ford, Muriel B., 13 Dencourt Cres, Basildon, Essex, U.K.	17.44	"	"
Forge, Keith C. G. (estate of), c/o Arthur Young, G.P.O. Box 1518N, Melbourne	22.74	"	"

Unclaimed Moneys Act 1962

Register of Unclaimed Moneys held by the—

<i>Name of Owner on Books and Last Known Address</i>	<i>Total Amount Due to Owner</i>	<i>Description of Unclaimed Money</i>	<i>Date when Amount first became Payable</i>
\$			
CRA GROUP SHARE REGISTRY— <i>continued</i>			
Fox, Edward D., P.O. Box 63, Mt. Hagen, P.N.G.	10.43	Dividend	5.5.83
Fox, John S. (estate of), c/o Russell Hay, P.O. Box 3537, Port Moresby, P.N.G.	10.43	"	"
Fox, Nollith E., P.O. Box 63, Mt. Hagen, P.N.G.	10.43	"	"
Frydman, Elizabeth, 16 Mawby Rd, Bently East	15.00	"	"
Fulton, David R., Lake Cottage, St. Fillans, Perthshire PH6 2NF, U.K.	28.56	"	"
Furness, Richard D., 30 Shaftesbury Rd, Wilton Salisbury Wilts, U.K.	13.51	"	"
Gabriel, Jennifer A., 26 Kevin St, Whitfield, Cairns, Qld.	10.43	"	"
Gairns, Stuart B., P.O. Box 162, Esperance, W.A.	19.71	"	"
Galt, Jean L., 13 Banole Ave, Prahran East	14.36	"	"
Garland, Lynette M., 18 Richardson Ave, Claremont, W.A.	52.17	"	"
Gascoigne, Margaret E., P.O. Box 101, Lawson, N.S.W.	20.85	"	"
Gavan McDonnell & Co. Pty. Ltd., 41 McLaren St, North Sydney, N.S.W.	15.00	"	"
Geddes, David J., "4 Ways", Kelvin, N.S.W.	12.81	"	"
Geddes, Edwin G., P.O. Box 55, Maryborough, Qld	36.00	"	"
Geddes, Lois J., "4 Ways", Kelvin, N.S.W.	12.00	"	"
Gho, Lian C., 57 Warburton Rd., Canterbury	20.00	"	"
Gibson-Watt, Robin, 9 Torres St., Red Hill, A.C.T.	44.00	"	"
Glasson, Lynne C., 108 Third Ave, Mt. Lawley, W.A.	16.35	"	"
Gleeson, Kim B., P.O. Box 6, Noosa Heads, Qld	30.00	"	"
Gooch, Neville T., 30 Mitre St, St Lucia, Qld	10.43	"	"
Goodman, Susan, 8A Wattle St, Killara, N.S.W.	12.00	"	"
Gordon, Keith, 111 Crown St, Wollongong, N.S.W.	11.60	"	"
Gordon, Keith B., c/o The Manager, Bank of N.S.W., 111 Crown St, Wollongong, N.S.W.	16.52	"	"
Grattidge, Rex W., c/o Dept. of Forests, Cape Hoskins, New Britain, P.N.G.	12.75	"	"
Green, Kelsey A., P.O. Box 2097, Laurel, Miss. 39440, U.S.A.	21.81	"	"
Greenwood, Phyllis, 52 The Ridgeway, Golders Green, London N.W.11, U.K.	11.42	"	"
Hales, Archibold T., Flat 201, Marine Towers, 34 Sol Harris Cres, Durban, S. Africa	12.96	"	"
Hamilton, Jane, 32 Wollombi Rd, Bilgola Plateau, N.S.W.	19.50	"	"
Hammond, Robert J., 39 Solar St, Coorparoo, Qld	75.00	"	"
Hannah, David Jnr., St Helena, Armidale, N.S.W.	13.38	"	"
Hardy, Edward T., 6 Province St, Boondall Heights, Qld	10.43	"	"
Harel, Monique, 22 Kingsway, Nedlands, W.A.	41.73	"	"
Harlip, Monte R., 45 New Bond St, London W1, U.K.	11.37	"	"
Harvey, Patricia I. J., c/o Scrimgeour Kemp-Gee & Co., 20 Copthall Ave, London EC2R 7J5, U.K.	32.64	"	"
Hasker, Peter J. S., 416 Mains Rd, Sunnybank, Qld	10.43	"	"
Hatrick, Albert, c/o Carruthers & Co., 44 Hunter St, Sydney, N.S.W.	11.59	"	"
Hauser, Lynette E., 64 Rosemount Rd, Nambour, Qld	10.89	"	"
Helderman, Cornelius, 12 Amperelaan, Haarlem T22014, Netherlands	28.98	"	"
Hillhouse, Mary-Ann, and Drury, Jane, c/o M. Hillhouse, 3/8 Darling St, South Yarra	27.00	"	"
Hole, George T., "Kala Pattar", No. 4 The Lea, Laithes, Penrith CA11 0AZ, U.K.	33.53	"	"
Holmes, James S., 35 Hilary St, Mt. Isa, Qld	30.00	"	"
Hudson, Bobby J., RT 1, Box 224, Collins, Miss. 39428, U.S.A.	13.71	"	"

Unclaimed Moneys Act 1962

Register of Unclaimed Moneys held by the—

<i>Name of Owner on Books and Last Known Address</i>	<i>Total Amount Due to Owner</i>	<i>Description of Unclaimed Money</i>	<i>Date when Amount first became Payable</i>
\$			
CRA GROUP SHARE REGISTRY— <i>continued</i>			
Hudson, Peter R., and Graeme A., 37 Telegraph Rd, Pymble, N.S.W.	32.01	Dividend	5.5.83
Hui, Wai K., G.P.O. Box 1138J, Melbourne	15.00	"	"
Hull, Jeannie D., 265 The Esplanade, Mt. Pleasant, W.A.	12.00	"	"
Humphreys, Francis G., 70 Somerlayton Cres, Fawkner	16.69	"	"
Hutchison, Bridget C., 35 Maning Ave, Sandy Bay, Tas.	15.00	"	"
Jackshell, Pty. Ltd., 32 Lyndhurst Cres, Hunters Hill, N.S.W.	14.77	"	"
Jackson, Sheila J., "Chelsea Park", Kenthurst Rd, Kenthurst, N.S.W.	10.43	"	"
Jameson-Evans, Dr Ann, 12 St James Tce, Winchester, Hants, U.K.	26.16	"	"
Jarvie, Marion A., Brewer, Michelle D. and Jones, Fay D., 14 Railway Pde, Caboolture, Qld	15.00	"	"
Jarvie, Peter J., 75 Harold Rd, Springvale South	75.00	"	"
Johnston, David M., P.O. Box 3, Aspley, Qld	15.00	"	"
Johnston, Jean C. B., "Forest Lodge", Glenora, Tas.	35.04	"	"
Johnston, Judith M., 20 Monmouth Rd, Westbourne Park, S.A.	38.80	"	"
Johnstone, Colin, Room 305, 590 George St, Sydney, N.S.W.	10.50	"	"
Jones, Alice C. M. and Price, Alice N. I., Plas Penucha Caerwys Mold, CLWYD CH7 5BH, U.K.	22.95	"	"
Jones, Colin E., Apartment 307A, 6533 Seaview Ave NW, Seattle, Wash. 98117, U.S.A.	12.75	"	"
Jones, Sheila W., Intelligence & Security Group, 6 (P1) CO BFPO 40, West Germany	14.28	"	"
Kay, Marie T., 617 Port Hacking Rd, Caringbah, N.S.W.	75.00	"	"
Kazimieras, Gvalda, 14 Helm St, Aspendale	75.00	"	"
Kearney, Jessie A. E., c/o L. Yung, 70 Thirteenth St, Warragamba, N.S.W.	17.39	"	"
Keith, Rosemary A., 17 Bridge Lane, London SW11 3AD, U.K.	76.50	"	"
Kennelly, John B., 405 Grand Junction Rd, Wingfield, S.A.	1 304.13	"	"
Khurana, Paresh K., Room 207, Colombo Crt, P.O. Box 171, Singapore 6, Singapore	211.47	"	"
Kiely, James, 31 Penn St, Mackay, Qld.	14.48	"	"
King Gardiner Investments Pty. Ltd., c/o John D. H. Arnott & Co., 88 Pitt St, Sydney, N.S.W.	20.87	"	"
King, Graeme D., P.O. Box 1034, Boroko, P.N.G.	10.43	"	"
King, Richard W. F., 19 Howitt St, Glen Iris	15.99	"	"
King, Thelma, 11 Werona Ave, Killara, N.S.W.	33.48	"	"
Kirby, Patrick B., Bayswater Hotel, Bayswater, W.A.	77.45	"	"
Kluge, Robert E. G., P.O. Box N 1704, Nassau, Bahamas	28.98	"	"
Knight, Rosie, 9 Kamiva St, Rochedale, Qld.	10.43	"	"
Knott, Roy McIver, c/o Business Development, P.O. Box 8, Kupiano CP, P.N.G.	46.42	"	"
Kramer, Karl J. T., P.O. Box 270, Wewak, P.N.G.	10.43	"	"
Lawless, Daphne E., 48 Langson Ave, Figtree, N.S.W.	12.50	"	"
Leahy, Matthew J., P.O. Box 425, Toowoomba, Qld.	10.43	"	"
Lee, Chui and Lynn, 14 Cervantes St, MacGregor, Qld.	13.04	"	"
Lewis, Anthony G., 10E Bracknell Gardens, Hampstead, London NW3, U.K.	21.27	"	"
Lim Dr, Phaik-Lim, 2C Tavoy Cl, Penang, Malaysia	28.98	"	"
Lim, Phang Y., Flat 1, 6 Houston Rd, Kensington, N.S.W.	15.00	"	"
Lindquist, Robert H., 109 McDonald St, Kalgoorlie, W.A.	16.80	"	"
Lindrup, Betty, Dunham Woods, Charcoal Rd, Bowdon Cheshire, U.K.	26.16	"	"

Unclaimed Moneys Act 1962

Register of Unclaimed Moneys held by the—

<i>Name of Owner on Books and Last Known Address</i>	<i>Total Amount Due to Owner</i>	<i>Description of Unclaimed Money</i>	<i>Date when Amount first became Payable</i>
\$			
CRA GROUP SHARE REGISTRY—continued			
Lockwood, Laurence R., Flat 8, 746 Beaufort St, Mt. Lawley, W.A.	12.90	Dividend	5.5.83
Loh, William, 1 Mildura St, Killara, N.S.W.	10.50	"	"
Lovett, Mary, c/o Wall Lehmann & Will, 109 Pitt St, Sydney, N.S.W.	64.48	"	"
Lyle, Julee H., 11 Moncur St, Woollahra, N.S.W.	16.02	"	"
Lyons, Norman R., Flat 4, 4 Ormond Gardens, Coogee, N.S.W.	15.00	"	"
Mace, Jennifer M., "Bimbimbi", Blackwater, Qld.	60.00	"	"
MacGibbon, John B., P.O. Box 1763, Christchurch, N.Z.	13.59	"	"
Macrae, Valerie B., c/o Harrison Knox and Leslie, G.P.O. Box 266, Sydney, N.S.W.	12.00	"	"
Maloney, Janet M., 109 Alexandra Rd, Ascot, Qld	21.73	"	"
Maloney, Peter F., P.O. Box 49, Port Moresby, P.N.G.	10.43	"	"
Maloney, Robert S., P.O. Box 49, Port Moresby, P.N.G.	10.43	"	"
Manser, Peter F., P.O. Box 635, Madang, P.N.G.	10.43	"	"
Mason, Harold P. and Dowling, Denise M. D., Flat 2, 63 Kitchener Rd, Ascot, Qld	30.00	"	"
McDonald, Laureen, 24 Wewak Pde, Heidelberg West	30.00	"	"
McDowall, Helen, Berry's Creek Rd, Mirboo North	20.56	"	"
McFadyen, Donald C. (estate of), c/o Currie & Cabarrus, 17 George St, Parramatta, N.S.W.	10.88	"	"
McGeoch, Robert H., 135 Parkway Ave, Hamilton, N.S.W.	15.00	"	"
McGuinness, John H., and Mary P., P.O. Box 543, Arawa, P.N.G.	25.94	"	"
McJannet, Alan H. D., 45 Drumalbyn Rd, Bellevue Hill, N.S.W.	10.26	"	"
McKnoulty, Patrick J. and Sheila, P.O. Box 416, Townsville, Qld	10.08	"	"
McLeod, Frances P., 27 Petmar St., The Gap, Qld	58.28	"	"
McNally, Max D., Pattison St, Emu Park, Qld	63.10	"	"
Meehan, Winifred, 126 Mooney St., Gulliver, Townsville	15.78	"	"
Menard Pty. Ltd., Flat 2, 18 The Avenue, Rose Bay, N.S.W.	15.00	"	"
Mengel, Joseph T., Apt 113, Carol Woods, Chapel Hill, North Carolina, U.S.A.	65.20	"	"
Merrill Richard, P.O. Box 180, Elsinore, California, U.S.A.	25.50	"	"
The Micharon Pastoral Co. Pty. Ltd., P.O. Box 169, Toronto, N.S.W.	17.39	"	"
Milko, Leonard, C/- P.N.G. Forestry Product, P.O. Box 71, Bulolo, P.N.G.	230.94	"	"
Miller, Jessie U. (estate of), C/- Colin J. James, 244 Forest Rd, Hurstville, N.S.W.	17.73	"	"
Mills Margaret A., 1/13 Sweet St, Mundingburra, Qld	97.50	"	"
Mills, Michael J., Flat 75, 30 Moore Rd, Harbord, N.S.W.	72.00	"	"
Mitchell, John P., "Marcourt", Lovett St, Manly Vale, N.S.W.	16.02	"	"
Mitrakos, Christos, 192 Concord Rd, Concord West, N.S.W.	300.00	"	"
Moffat, William and Jane N., 2201 Ambassador Rd, Albuquerque, U.S.A.	21.35	"	"
Morganstern, Carol J., G.P.O. Box 2737X, Melbourne	45.00	"	"
Muldownie, Dennis J., Post Office, Tom Price, W.A.	10.43	"	"
Murray, Michael F., and Gina A., Westminster School, Marion, S.A.	11.30	"	"
Murray, Thomas F. VI, Unit 1, 128 Forrester St, Peppermint Grove, W.A.	11.59	"	"
Neo, Koh Lian, C/- Seagroatt & Campbell, P.O. Box 790, Kuala Lumpur, Malaysia	144.90	"	"
Ng, David S. C. and Dorothy I. K., 7 Dei Tiong Ham Pk, Singapore	25.50	"	"
Nicholls, Graham, C/- Curragh Queensland Mining Ltd., G.P.O. Box 807 Brisbane, Qld	28.98	"	"

Unclaimed Moneys Act 1962

Register of Unclaimed Moneys held by the—

<i>Name of Owner on Books and Last Known Address</i>	<i>Total Amount Due to Owner</i>	<i>Description of Unclaimed Money</i>	<i>Date when Amount first became Payable</i>
\$			
CRA GROUP SHARE REGISTRY— <i>continued</i>			
Nicol, Margaret A., P.O. Box 2274, Darwin, N.T.	17.39	Dividend	5.5.83
Nicol, Robert G., P.O. Box 2274, Darwin, N.T.	17.39	"	"
Nicoll, David A., William St, Beaudesert, Qld	97.31	"	"
O'Brien, John, "Marionvale", Hughenden, Qld	226.70	"	"
O'Donnell, Denis, 134 Slade Lane, Manchester, U.K.	25.50	"	"
O'Keeffe, Christine, 15 Brown St, Toowoomba, Qld	10.43	"	"
O'Riordan, Richard A., Unit 1, 120 Stafford Rd, Kedron, Qld	15.00	"	"
Ogilvy, Ian MacK., 73 York St, Richmond	20.87	"	"
Oliver, Sarah, 93 Mill Hill Rd, Acton, London, U.K.	10.20	"	"
Ottaway Thomas V., and Ellis Maureen I., C/- McCay & Thwaites, 321 Camberwell Rd, Camberwell	14.50	"	"
Overseas Nominee Co. Inc., C/- Citybank, N.A., 20 Exchange Pl, New York, U.S.A.	15.30	"	"
Page, Frederick and Thomas and Robert Jnr, Stow Acres Country Club Inc., Randall Rd, Stow Mass., U.S.A.	14.28	"	"
Paine, John E., 39 Shakespeare Cres, Fraser, A.C.T.	21.57	"	"
Pakula, Irena, 20 Need St, Enfield, S.A.	21.73	"	"
Palgrave-Brown, Alan and Alastair and Ian, Flat 81, 15 Portman Sq, London, U.K.	13.59	"	"
Patterson, Eileen, C/- Supply and Transport, Posts and Telegraph, P.O. Box 6352, Boroko, P.N.G.	10.43	"	"
Paul, Desmond D., P.O. Box 153, Mackay, Qld	49.39	"	"
Peat, Leonie, Flat 1, 2 Edgecliff Ave, Coogee South, N.S.W.	16.00	"	"
Peckover, Anne, 35 Maldon St, Penrith, N.S.W.	10.43	"	"
Penington, Anthony J., 78 Bell St, Fitzroy	17.40	"	"
Penola Holdings Pty. Ltd., P.O. Box 105, Penola, S.A.	100.08	"	"
Perrin, Marilyn, Flat 19, 35 Walsh St, South Yarra	15.99	"	"
Peter, Alma A., (estate of), c/o H. A. Whiting & Co., 177 Buckley St, Essendon	10.64	"	"
Pinalli, Edward, c/o Cwth Trading Bank, Mt. Isa, Qld	15.00	"	"
Pitt, Georgia F., 93 Kooyong Koot Rd, Hawthorn	10.43	"	"
Podmore, Linda A., 1 Falcon Plc, Wagga Wagga, N.S.W.	11.36	"	"
Pope, Matthew W., c/o Smiths Dry Cleaners, 244 Hannan St, Kaigoorlie, W.A.	15.00	"	"
Porcella, Richard, 2611 S. W. Adams, Seattle, Washington, U.S.A.	10.43	"	"
Pretsch, Felix H., 127 Cabana Apts, 516E Glenn Ave, Auburn, Alabama 36830, U.S.A.	21.42	"	"
Puehringer, Franz X., 10 Kinglake Rd, Whittlesea	28.98	"	"
Ray, Edward, 94 Macquarie Gve, Caves Beach, N.S.W.	26.43	"	"
Read, Peter H., c/o Laura Johnson Home, Mt. Isa, Qld	30.00	"	"
Renshaw, Margaret, 1 Alfred Place, Turrumurra South, N.S.W.	21.73	"	"
Ridgway, Evelyn M., Orchard Cottage, Gorey, Jersey, Channel Islands	12.43	"	"
Rivero, Paula D., Avenida De Escaleritas 38, Box 98, Las Palmas, Spain	10.43	"	"
RJP Pty. Ltd., 58 Dalgetty Rd, Beaumaris	57.03	"	"
Robinson, John G. E., 203 Tryon Rd, Lindfield, N.S.W.	10.39	"	"
Robinson, Sidney H., P.O. Box 45, Avalon Beach, N.S.W.	63.99	"	"
Rollo, Helen L., 203 Domain Rd, South Yarra	11.05	"	"
Roper, Rita, P.O. Box 1131, Townsville, Qld	13.14	"	"
Royal London Mutual Insurance Society Limited, Royal London House, Middleborough, Colchester CO1 1RA, U.K.	115.92	"	"

Unclaimed Moneys Act 1962

Register of Unclaimed Moneys held by the—

<i>Name of Owner on Books and Last Known Address</i>	<i>Total Amount Due to Owner</i>	<i>Description of Unclaimed Money</i>	<i>Date when Amount first became Payable</i>
\$			
CRA GROUP SHARE REGISTRY—continued			
Rudd, Margaret, Flat 9, 201 Lake St, Cairns, Qld	17.39	Dividend	5.5.83
Rudder, Alan J., 72 Quirk St, Dee Why, N.S.W.	15.00	"	"
Rudolph, Peter C., 16 Bridge View Cres, Forestville, N.S.W.	30.73	"	"
Ryott, Rome S., 1 East Hill, Lymington, Hants, U.K.	15.30	"	"
Sampson, Mary K., 19 Jean St, McKinnon	104.33	"	"
Sanderson, John S. S., 7 De Bevoir Square, London N1, U.K.	12.75	"	"
Sanderson, Theonilla G., 4 Doubell Cl, Glen Waverley	10.43	"	"
Sawoff, Irene, 54 Alexandra St, South Yarra	39.11	"	"
Scanlon, Ann V., P.O. Box 31, Surrey Hills	15.00	"	"
Scanlon, Margaret C., 12 Monterey St, Wacol, Qld	75.00	"	"
Schofield, Guy R., P.O. Box 1791, Boroko, P.N.G.	10.43	"	"
Schofield, Roland B., P.O. Box 1791, Boroko, P.N.G.	10.43	"	"
Scotis, Peter J., and Sandra P., 4 Daniell Plc, Kew	70.40	"	"
Seeto, Jenny L. K., 374 Capalaba Rd, Mt. Gravatt, Qld.	10.43	"	"
Seeto, Richard and Wendy, Flat 1, 4/10 Darling St, Kensington, N.S.W.	20.87	"	"
Seeto, Thomas W. S., P.O. Box 41, Lae, P.N.G.	10.43	"	"
Sekiguchi, Koyo, c/o Mitsubishi Corp., 6-3 Marunouchi 2-Chome Chiyoda-Ku, Tokyo, Japan	12.75	"	"
Setu, Ami C., P.O. Box 62, Emerald, Qld	17.75	"	"
Shaker, Jack, 5 The Strand, Williamstown	43.46	"	"
Shelley, Josephine M., 43 Observatory Rd, Mt. Dandenong	14.27	"	"
Shields, David H., 161 Brownside Rd, Burnside, Rutherglen, Glasgow, U.K.	13.77	"	"
Simpson, Warwick E., Clarksville, Milton Rd 2, Otago, N.Z.	10.43	"	"
Sinclair, Brian J., c/o Cwth Banking Corp., Moorabool and Mallop Sts, Geelong	10.43	"	"
Smith, John A. and Pamela E., Singh St, Woolbrook, N.S.W.	15.00	"	"
Smith, Walter P., 11 Charles St, Ryde, N.S.W.	750.00	"	"
Sobieska Pty. Ltd., P.O. Box 75, Carlton South	52.17	"	"
Soetens, Nettie, P.O. Box 551, Brookvale, N.S.W.	30.00	"	"
Sommerville, Peter, 133/69 St. Marks Rd, Randwick, N.S.W.	15.00	"	"
Sorrell, John L., 105-D Meyer Crt, Meyer Rd, Singapore 15, Singapore	45.69	"	"
Spring, James, Flat 5, 28 Bland St, Ashfield, N.S.W.	75.00	"	"
Squire, William J., P.O. Box 110, Panguna, P.N.G.	19.07	"	"
Stephen, Ernest A. and Dorothy J., South West Highway, Donnybrook, W.A.	75.00	"	"
Stephens, Donald G., Lot 4, Nyari Rd, Kenthurst, N.S.W.	10.43	"	"
Storer, Ronald D., P.O. Box 341, Magill, S.A.	26.08	"	"
Street, Charles, P.O. Box 5614, Boroko, P.N.G.	10.43	"	"
Tacheci, Vicki A., P.O. Box 380, Canberra City, A.C.T.	30.00	"	"
Taylor, Jennette D., 30 Crowther Ave, Greenwich, N.S.W.	15.00	"	"
Tela Pty. Ltd., c/o A. R. Styles, Flat 21, 50 Upper Pitt St, Kirribilli, N.S.W.	304.44	"	"
Thio, Sauw H., 207 Christo Rd, Waratah, N.S.W.	30.00	"	"
Thomason, Stephen R. and Aileen F., 1378 Gympie Rd, Aspley, Qld	20.24	"	"
Tout, Marjory L., 17 Cremorne Rd, Cremorne, N.S.W.	24.00	"	"
Trevor, Charles M., 15 Clarke St, Hendra, Qld	15.00	"	"
Trinity College of Music, London, 11 Mandeville Plc, London W1M 6AQ, U.K.	20.40	"	"
Trotter, Timothy N., "Kirston", 23 Rupert St, Windsor, Qld	13.04	"	"
Turner, Archie C., 229 Owen Boulevard, Willowdale, Ontario, Canada	52.17	"	"

Unclaimed Moneys Act 1962

Register of Unclaimed Moneys held by the—

<i>Name of Owner on Books and Last Known Address</i>	<i>Total Amount Due to Owner</i>	<i>Description of Unclaimed Money</i>	<i>Date when Amount first became Payable</i>
\$			
CRA GROUP SHARE REGISTRY—continued			
Turner, Ronald M. (estate of), c/o Kleinworth Benson Ltd., The Lawn, Bath Rd, Newbury, Berk RG13, 1QN, U.K.	16.75	Dividend	5.5.83
Twin, Mervyn R., 96 Butler St, Mt. Isa, Qld	15.16	"	"
Ulster Bank Provident Fund Investments Limited A A/C, 35 Waring St, Belfast, Northern Island	434.71	"	"
Vartuli, Jeffrey, 583 Williams St, Broken Hill, N.S.W.	14.48	"	"
Virgin, James T., 10 Park Cres, Caulfield	30.00	"	"
Wadge, Dorothea C., "Beckington", Doyle Rd, St. Peter Port, Guernsey, Channel Islands	10.50	"	"
Ward, Adrian G., P.O. Box 84, Rabaul, P.N.G.	57.96	"	"
Ward, Petrah, P.O. Box 84, Rabaul, P.N.G.	57.96	"	"
Waringah Theatres Pty. Ltd., P.O. Box 45, Avalon Beach, N.S.W.	32.01	"	"
Webster, Thomas E. (estate of), c/o Penney Castello Carlebach & Co., 21 Dublin St, Edinburgh, U.K.	27.20	"	"
Weston, Noel P., Unit 2, 19A Arthur St, Northfield, S.A.	173.88	"	"
Whitcomb, Arthur and Chiltem-Hunt, Percy and Eileen, c/o Barclays Bank Limited, 72 Cheapside, London EC2, U.K.	14.96	"	"
Whitman, Jeffrey A. and Julie E., 51 Fisher St, Myrtle Bank, S.A.	10.08	"	"
Wicks, John S. (estate of), c/o Buddle Findlay, P.O. Box 2694, Wellington, N.Z.	35.70	"	"
Williams, Betty, 31A Young St, Wahroonga, N.S.W.	26.08	"	"
Williams, Christine I., Swallow St, Slade Point, Qld	17.04	"	"
Williams, John, Hesworth, Fittleworth, Pulborough, Sussex, U.K.	27.25	"	"
Williams, Stanley D. N., P.O. Box 668, Lae, P.N.G.	10.43	"	"
Wong, Denis, 18 Campbell St, Sydney, N.S.W.	75.00	"	"
Wong, Lawrence, c/o Jackson Graham Moore & Ptns, 56 Pitt St, Sydney, N.S.W.	15.00	"	"
Woolcock, Peter W., 5 High St, Launceston, Tas.	15.00	"	"
Wren, Kathleen R., Residence No. 2, Balimo, P.N.G.	10.43	"	"
Wright, John M. W. and Park, John M., Newtown House, St. Margarets, Dublin, Eire	10.16	"	"
Yag Holdings Pty. Ltd., 55 Hallam Belgrave Rd, Belgrave	15.00	"	"
Yarwood, Arthur (estate of), c/o Dean & Co., 62 Hagley Rd, Stourbridge DY8 1QD, U.K.	30.19	"	"
Kue Yen, Hew and Sew, Conzinc Rio Tinto, Malaysia SDN BHD, P.O. Box 202, Dengkil, Kajang, Selangor, Malaysia	10.43	"	"
Chong, Yeow F., 38 Conway Dve, Singapore 1955, Singapore	43.46	"	"
Ziesing, Peter R., P.O. Box 776, Port Moresby, P.N.G.	10.43	"	"
Albert G. Hanson Pty. Ltd., 16 Pacific Blvd, Beaumaris	24.00	"	3.11.83
Allpress, Charles F., Carus Park, Lancaster LA2 6BN, U.K.	17.44	"	"
Anderson, Keith D., (estate of), c/o W. K. Anderson, 33 Chapel St, St. Kilda	48.33	"	"
Anderson, Ruth, 10A John Islip St, London SW1, U.K.	17.21	"	"
Andrews, Roger E., RMB 418, Boyup Brook, W.A.	34.78	"	"
Annandale-James, John A., and Patricia E., 5 Renwick St. South Perth, W.A.	53.22	"	"
Archer, Beryl, 1456A Pacific Hwy, Turramurra, N.S.W.	14.66	"	"
Aston, Frank and Smith, Henry J., and Ockerby, William T., 93 Simpson St, Mt. Isa, Qld.	70.00	"	"
Audoa, Eve L., c/o University of Papua New Guinea, P.O. Box 4694, Port Moresby, PNG	19.35	"	"

Unclaimed Moneys Act 1962

Register of Unclaimed Moneys held by the—

<i>Name of Owner on Books and Last Known Address</i>	<i>Total Amount Due to Owner</i>	<i>Description of Unclaimed Money</i>	<i>Date when Amount first became Payable</i>
§			
CRA GROUP SHARE REGISTRY— <i>continued</i>			
Bachem, Hans E., 29 Avenue D'Arbere, F-01220, Divonne-Les-Bains, France	193.55	Dividend	3.11.83
Baker, Linda J., 27 Astrop Rd, King's Sutton, Banbury, Oxon, U.K.	15.60	"	"
Baker, Masako, 84-967 Ogien Gomatsudo Futo, Ito City, Shizuoka-Ken, Japan	12.75	"	"
Barnes, Neil J., 13 Latina Ave, Seven Hills, Qld.	64.52	"	"
Barnes, Richard G., The Mount, Fernyhalgh Lane, Fulwood, Preston, Lanc, U.K.	19.50	"	"
Benschler & Sons Pty. Ltd., 1611 Botany Rd, Botany, N.S.W.	70.00	"	"
Berger, Felix, P.O. Box 85, Gnowangerup, W.A.	12.15	"	"
Bisar, Udil, Mapor Village, Karkar Is Madang, P.N.G.	19.35	"	"
Bloom, Geoffrey S., c/o M. Bloom, 10th Floor, 307 Pitt St, Sydney, N.S.W.	10.75	"	"
Buskovic, Nicola, 10 Watson Ave, Box Hill North	29.03	"	"
Bowen, George H., P.O. Box 328, Milsons Point, N.S.W.	110.99	"	"
Bracey, Ian F., & Whiteaway, George B., 17 Childs Pl, London SW5 9RB, U.K.	10.71	"	"
Bradfield, Frances H., 4 Lot Lane, Hunters Hill, N.S.W.	15.33	"	"
Bradfield, Geoffrey G., 34 Mills St, Hampton	20.06	"	"
Bradley, David G., P.O. Box 327, Parramatta, N.S.W.	12.93	"	"
Braine, Margaret J., 15 Callington Ave, City Beach South, W.A.	26.88	"	"
Bressow, Gary L., P.O. Box, Nairne, S.A.	28.14	"	"
Brice, Sheila M., Flat 11, 97 Chumley St, Windsor	19.35	"	"
Brissoni, Bruna, P.O. Box 1247, Boroko, P.N.G.	16.13	"	"
Brissoni, Giuseppe, P.O. Box 1247, Boroko, P.N.G.	24.19	"	"
Brooks, Barry R., c/o McGirr & Associates Pty. Ltd., 20 Loftus St, Sydney, N.S.W.	40.32	"	"
Brothers, William M., 14001 Goldmark, Suite 212, Dallas, Texas 75240, U.S.A.	10.75	"	"
Brown, Tara D., & Brown, Mitchell A., 212 Yarra St, Hawthorn	43.01	"	"
Brunstrom, Betty G., 12660 Shorewood Drive SW, Seattle, Wash 98146, U.S.A.	19.94	"	"
Brynervall, Ove, Tappgatan 11B, Sodertalje S-15133, Sweden	10.20	"	"
Buderus, Margaret H., c/o Papua Agencies, P.O. Box 126, Port Moresby, P.N.G.	19.35	"	"
Cahn, Michele, c/o Whitney National Bank Trust Dept., P.O. Box 61260, New Orleans, LA 70161, U.S.A.	16.13	"	"
Calder, Charlotte B., 12 Terry St, Balmain, N.S.W.	19.11	"	"
Carey, Russell J., 76 Buck St, Broken Hill, N.S.W.	14.51	"	"
Case, Virginia & Case, Jonathan & Catherine, Cove House, 24 Esplanade South, George Town, Tas.	11.13	"	"
Chambers, David, c/o Midland Bank Limited, Library Pl, St. Helier, Jersey, Channel Islands	10.08	"	"
Charlton, Freda c/o R. G. A. McGaw, 6 Barnfield, Iver, Bucks, U.K.	11.47	"	"
Chayter, Irene, 16 Cooper Ave, Moorebank, N.S.W.	15.00	"	"
Chee, Cedric c/o C. & B. Chee Pty. Ltd., P.O. Box 214, Lae, P.N.G.	19.35	"	"
Cheetham, John A., 2005 Asian House, Hong Kong, Hong Kong	19.59	"	"
Chester, Irene E., Camelford, Campbell Town, Tas.	44.74	"	"
Chiplin, Toni R., 10 McLeod St, Hurstville, N.S.W.	51.08	"	"
Christian, Charles H. (estate of), c/o Ralph W. King & Yuill, G.P.O. Box 5320, Sydney, N.S.W.	40.32	"	"

Unclaimed Moneys Act 1962

Register of Unclaimed Moneys held by the—

<i>Name of Owner on Books and Last Known Address</i>	<i>Total Amount Due to Owner</i>	<i>Description of Unclaimed Money</i>	<i>Date when Amount first became Payable</i>
§			
CRA GROUP SHARE REGISTRY—continued			
Clarke, Douglas K., Geranium, S.A.	102.60	Dividend	3.11.83
Clarke, Gwenneth M., Flat 3, 28 Kensington Rd, South Yarra	32.26	"	"
Coffey, Frances L., 212 Auburn Rd, Hawthorn	19.35	"	"
Coghlan, William, 32 Rowland St, Kew	16.13	"	"
Colegrove, John W., G.P.O. Box 4981, Sydney, N.S.W.	16.13	"	"
Connor, Priscilla J., 145 Faulkner St, Armidale, N.S.W.	38.28	"	"
Creighton, Rex, c/o S. Chaplin, Larrass Lee via Molong N.S.W.	12.90	"	"
Cretser, Samuel N., c/o Bechtel Wke, P.O. Box 12, Kieta, P.N.G.	19.35	"	"
Crostrom Pty. Ltd., Unit 2, 7 Binnie St, Brighton East	31.32	"	"
Cubasch, Vulker, 1 Hope St, Pymble, N.S.W.	53.76	"	"
Curran, Henry G. Snr, and Curran, Henry G. Jnr, and Curran, Nicholas, c/o H. G. Curran Jnr, 103 Arbuelo Way, Los Altos, CA 94022, U.S.A.	23.80	"	"
D'Albora, Olive M., 81 Fitzwilliam St, Kew	11.15	"	"
Davies, Edwin L. P., 405 The Terrace, Port Pirie, S.A.	13.58	"	"
Davis, Linda P., 70 West Main St, North Boro, Massachusetts 01532, U.S.A.	12.75	"	"
Dawson, Frederick A., Post Office, Glenella, Qld	40.32	"	"
Deletang, Pierre R. and Deletang Claudie G., 7802 Benton St, Hurstville, ALA 35802, U.S.A.	11.22	"	"
Dewhurst, Roger H., P.O. Box 2142, Rotorua, N.Z.	18.64	"	"
Dillon, John V., c/o Dept Aboriginal and Island Affairs, Weipa South, Qld	10.00	"	"
Djokovic, Erik D., P.O. Box 782, Arawa, P.N.G.	16.47	"	"
Dodworth, Eva (estate of) and Dodworth, Paul A. C. and Price, Leonard H., c/o Wannop and Falconer, 14 Sudley Rd, Bognor Regis, PO 21, 1 EX, U.K.	11.47	"	"
Donaldson, Angus F., c/o Clydesdale Bank Limited, 29 George St., Edinburgh EH2 2NL, U.K.	12.15	"	"
Downer, Jane F., 19A High St, Portsmouth, Hants, U.K.	32.26	"	"
Drane, Francis H., c/o J. E. Drane, 55/29 Gerard St, Cremorne, N.S.W.	13.75	"	"
Duveen, John O., c/o Westminster Bank Ltd., 1 Cavendish Square, London W1, U.K.	30.19	"	"
E. G. and H. Nominees Pty. Ltd., 421 Bourke St, Melbourne	27.03	"	"
Ellis, Kathleen R., 50 Austral Tce, Malvern, S.A.	24.96	"	"
Emery, David L., Unit 3, 303 Montacute Rd, Athelstone, S.A.	19.35	"	"
Everingham, Ian A. and Lloyd, Margaret E. and Skujins, Andrew, 92 Rutledge St, Eastwood, N.S.W.	10.75	"	"
Eyre, Jane E., 31 Shawfield St, London SW3, U.K.	13.02	"	"
Farrelly, Keith J., c/o J. G. Farrelly, Casuarina Ave, Lae, P.N.G.	19.35	"	"
Faulkner, William G., 32 The Avenue, McCrae	53.76	"	"
Ferner, Martin H. and Ferner Eleanor J., 75 Nicholson Rd, Wellington, N.Z.	50.31	"	"
Fielden, Arthur and Fielden, Kay A., 16 Rankin St, Campbell, A.C.T.	10.89	"	"
Finch, Lois A. K., c/o Cazenove & Co., 12 Tokenhouse Yard, London EC2R 7AN, U.K.	51.00	"	"
Finlay, Ronald and Finlay, Jennifer, 34 Wyadra Ave, Harbord, N.S.W.	14.00	"	"
Fisher, Gladys C., 8 Young St, Wahroonga, N.S.W.	30.00	"	"
Fitzgerald, Edward A., c/o R. A. Smith, 25 Bassett Ave, Southampton, Hants, U.K.	40.32	"	"
Foletta, Henry G., 34 St. Georges Rd, Toorak	255.38	"	"

Unclaimed Moneys Act 1962

Register of Unclaimed Moneys held by the—

Name of Owner on Books and Last Known Address	Total Amount Due to Owner	Description of Unclaimed Money	Date when Amount first became Payable
\$			
CRA GROUP SHARE REGISTRY—continued			
Ford, Muriel B., 13 Dencourt Cres, Basildon, Essex, U.K.	17.44	Dividend	3.11.83
Forwood, Barbara M. L., (estate of) c/o Northcote & Co., P.O. Box 548, Cophthall Cl, London EC2P, 2JJ, U.K.	47.60	"	"
Fox, Edward D., P.O. Box 63, Mt. Hagen, P.N.G.	19.35	"	"
Fox, John S., c/o Russell Hay, P.O. Box 3537, Port Moresby, P.N.G.	19.35	"	"
Friedl, Frank, 1 Docker St, Elwood	16.13	"	"
Gairns, Stuart B. (Dr.) P.O. Box 162, Esperance, W.A.	19.71	"	"
Galetto, Robyn D., c/o Comalco Limited, 95 Collins St, Melbourne	14.51	"	"
Garland, Lynette M., 18 Richardson Ave, Claremont, W.A.	96.77	"	"
Garsia, Anthony R., Hilltop, Old Gympie Rd, Kallangur, Qld.	19.35	"	"
Gascoigne, Margaret E., P.O. Box 101, Lawson, N.S.W.	32.66	"	"
Geddes, David J., "4 Ways", Kelvin, N.S.W.	12.81	"	"
Geddes, Jane Mac., 32 Days Ave, Yeronga, Qld.	15.81	"	"
Geddes, Lois J., "4 Ways", Kelvin, N.S.W.	12.00	"	"
Gee, Peter, 115 Celtic Cres, Ellerslie, Auckland 5, N.Z.	16.13	"	"
Gethin, Alexander W., c/o Scrimgeour Kemp-Gee & Co., 20 Cophthall Ave, London EC2R 7JS, U.K.	50.31	"	"
Gho, Lian C., 57 Warburton Rd, Canterbury	20.00	"	"
Gibbons, Aileen M., (estate of) c/o Thorne, Beckett & Crofts, Old Bank Chm, Lich Gates, Wolverhampton, WV1 1UA, U.K.	12.75	"	"
Gibbs, Nellie E., c/o M. E. Fuller, 6 Castlefield St, Bondi Beach, N.S.W.	570.49	"	"
Gilbert, Robert R., Hawthorn Rd, Mt. Barker, S.A.	16.13	"	"
Glasson, Lynne C., 108 Third Ave, Mt. Lawley, W.A.	15.05	"	"
Gleeson, Kim B., P.O. Box 6, Noosa Heads, Qld.	14.00	"	"
Gooch, Neville T., 30 Mitre St, St. Lucia, Qld.	19.35	"	"
Goodrick, John P., P.O. Box 76, Te Awamuto, N.Z.	19.35	"	"
Gordon, Keith B., c/o The Manager, Bank of N.S.W., 111 Crown St, Wollongong, N.S.W.	20.19	"	"
Goudie, Peter J., c/o P. T. International Nickel Indonesia, 50 Robinson Rd, 10-00, Singapore 0106, Singapore	35.17	"	"
Kendall, Christopher F., Granger, The White House, Hickling, Melton Mowbray, Leics, U.K.	30.19	"	"
Grant, Stanley W., 12 Lawrie Park Cres, Sydenham, London SE26, U.K.	28.63	"	"
Green, Lois M., 44 Brooks St, Lane Cove, N.S.W.	39.45	"	"
Greig, Aaron T., 36 Pelham Rd, Port Pirie, S.A.	12.10	"	"
Greiner, Carlton (Fr.) P.M.B. Catholic Mission, Kuraio, via, Kieth N.S.F., P.N.G.	64.52	"	"
Hallett, Maude A., Flat 2, 2 Wilky Crt, Fulham Gardens, S.A.	19.35	"	"
Hamilton, Jane, 32 Wollombi Rd., Bilgola Plateau, N.S.W.	19.50	"	"
Hammond, Robert J., 39 Solar St, Coorparoo, Qld.	35.00	"	"
Hannah David (jnr), St. Helena, Armidale, N.S.W.	13.38	"	"
Harel, Monique, 22 Kingsway, Nedlands, W.A.	77.41	"	"
Harrison, Ronald R., and Margaret H., 95 Kenmore Rd, Kenmore, Qld.	53.76	"	"
Hauser, Lynette E., 64 Rosemount Rd, Nambour, Qld.	10.89	"	"
Havard, Mary B., 6 St. Katherines Precinct, Regents Park, London NW1 4HH, U.K.	29.93	"	"
Hayes, Barry M., and Valerie J., P.O. Box 494, Lac, P.N.G.	14.51	"	"

Unclaimed Moneys Act 1962

Register of Unclaimed Moneys held by the—

<i>Name of Owner on Books and Last Known Address</i>	<i>Total Amount Due to Owner</i>	<i>Description of Unclaimed Money</i>	<i>Date when Amount first became Payable</i>
\$			
CRA GROUP SHARE REGISTRY— <i>continued</i>			
Hayne, Albert S., 18 Lille St, New Lambton, N.S.W.	64.52	Dividend	3.11.83
Herkenhoff, Frederick A. (Capt.) P.O. Box 617, Fremantle, W.A.	89.89	"	"
Hicks, Marion I., 10 McKinlay St, Narrabundah, A.C.T.	10.49	"	"
Hillhouse, Mary-Ann and Drury, Jane L., c/o M. Hillhouse, 3/8 Darling St, South Yarra	27.00	"	"
Hines, John R., 2621 Trentwood Blvd, Orlando, FLA 32809, U.S.A.	10.75	"	"
Hirai, Takau, 27 Clonmore St, Beaumaris	14.51	"	"
Hodge, Christopher P., 22 Brown St, Norwood, S.A.	22.41	"	"
Hohnen, Geoffrey G., 14 Thomas St, McMahon's Point, N.S.W.	11.69	"	"
Holmes, James S., 35 Hilary St, Mt Isa, Qld	14.00	"	"
Hudson, Peter R. and Graeme A., 37 Telegraph Rd, Pymble, N.S.W.	32.01	"	"
Humphreys, Francis G., 70 Somerlayton Cres, Fawkner	30.97	"	"
Hutchison, Bridget C., 35 Maning Ave, Sandy Bay, Tas.	15.00	"	"
Ian Partridge Pty. Ltd., P.O. Box 13, Brunswick Junction, W.A.	12.81	"	"
Ireland, Christine U., 173 Esplanade, Cairns, Qld.	22.41	"	"
Irvine-Fortescue, Bridget U. (estate of), c/o Wood and Awdry, 3 St Mary St, Chippenham SN15 3JL, U.K.	120.97	"	"
Itzhaki, Dr Shaul, 468 Parris Wood Rd, East Didsbury, Manchester M20 0QQ, U.K.	80.65	"	"
Jackshell Pty. Ltd., 32 Lyndhurst Cres., Hunters Hill, N.S.W.	27.41	"	"
Jackson, Sheila J., "Chelsea Park", Kenthurst Rd, Kenthurst, N.S.W.	19.35	"	"
Annandale-James, John A. and Patricia E., P.O. Box 67, Leinster, W.A.	13.35	"	"
Jameson-Evans, Dr Anne, 12 St James Tce, Winchester, Hants., U.K.	26.16	"	"
Jarvie, Peter J., 75 Harold Rd, Springvale South	35.00	"	"
Johnson, Tom D. (estate of), c/o J. Johnson, Hunt and Hunt, 54 Carrington St, Sydney, N.S.W.	12.15	"	"
Johnstone, Colin, Room 305, 590 George St, Sydney, N.S.W.	10.50	"	"
Jones, Thomas (estate of), c/o Lupton Fawcett Bell Cumming and Co., 29 Bond St, Leeds LS1 5BG, U.K.	11.06	"	"
Kaufmann, Eileen M. H., "Benerembah", Fellows Rd, Pt Lonsdale	24.69	"	"
Kay, Marie T., 617 Port Hacking Rd, Caringbah, N.S.W.	35.00	"	"
Kazimieras, Gvalda, 14 Helm St., Aspendale	35.00	"	"
Kearney, Jessie A. E., c/o L. Yung, 70 Thirteenth St, Warragamba, N.S.W.	32.26	"	"
Kennon, Eleanor C., 60 Union St, Northcote	16.13	"	"
Kestle, Helen M., 2 Akoonah Pl., Peakhurst, N.S.W.	35.36	"	"
King, Richard W. F., 19 Howett St, Glen Iris	15.99	"	"
Kingham, Hugh J., c/o Hamilton Veterinary Supplies, Te Rapa Rd, Hamilton, N.Z.	10.75	"	"
Kipluks, John P., 9 Chacago St, Maribyrnong	13.60	"	"
Kirby, Patrick B., Bayswater Hotel, Bayswater, W.A.	26.02	"	"
Kirk, Michael (estate of), c/o Capel-Cure Myers, Bath House, Holborn Viaduct, London, EC1A 2EU, U.K.	12.45	"	"
Knott, Roy McL., c/o Business Development, P.O. Box 8, Kupiano CP, P.N.G.	46.42	"	"
Kramer, Karl J. T., P.O. Box 270, Wewak, P.N.G.	19.35	"	"
Lachlan, Clarence F., "Malabar Flats", 133 Smith Street, West Darwin, N.T.	11.06	"	"
Laird, Audrey C. and Kenneth J., c/o K. J. Laird, P.O. Box 583, Gisborne, N.Z.	47.94	"	"

Unclaimed Moneys Act 1962

Register of Unclaimed Moneys held by the—

Name of Owner on Books and Last Known Address	Total Amount Due to Owner	Description of Unclaimed Money	Date when Amount first became Payable
\$			
CRA GROUP SHARE REGISTRY—continued			
Lam; Hui Sai Kuan, 2 Rutland Quadrant, Kowloon, Hong Kong	12.72	Dividend	3.11.83
Langley, David W., 31 Avondale St, Hampton	16.66	"	"
Latham, John A. and Wilmot E., 15 Seaview Rd, Frankston	38.71	"	"
Lawless, Daphne E., 48 Langson Ave, Figtree, N.S.W.	12.50	"	"
Le Mare, Sarah J., 605 Upper Brookfield Rd, Upper Brookfield, Qld	16.13	"	"
Leahy, Matthew J., P.O. Box 425 Toowoomba, Qld	19.35	"	"
Lennon, Paul A., Austin Hospital, Heidelberg	11.61	"	"
Lewis, Anthony G., 10E Bracknell Gardens, Hampstead, London NW3, U.K.	21.27	"	"
Lockwood, Laurence R., Flat 8, 746 Beaufort St, Mt. Lawley, W.A.	12.90	"	"
Loh, William, 1 Mildura St, Killara, N.S.W.	10.50	"	"
Lohberger, John, c/o Taxation Department, P.O. Box 777, Port Moresby, P.N.G.	16.13	"	"
Lyle, Julee H., 11 Moncur St, Woollahra, N.S.W.	16.02	"	"
Mace, Jennifer M., "Bimbimbi", Blackwater, Qld.	28.00	"	"
Mackie, William, P.O. Box 465, Bowen, Qld.	72.00	"	"
MacKinnon, Muriel J., "Langi Willi", Linton	32.97	"	"
Mallaby, Richard J., 33 Watkins Rd, Wangi, N.S.W.	11.52	"	"
Maloney, Janet M., 109 Alexandra Rd, Ascot, Qld.	40.32	"	"
Maloney, Peter F., P.O. Box 49, Port Moresby, P.N.G.	19.35	"	"
Maloney, Robert S., P.O. Box 49, Port Moresby, P.N.G.	19.35	"	"
Manser, Peter F., P.O. Box 635, Madang, P.N.G.	19.35	"	"
Martin, Margaret, c/o Kings Cross Internat Store, 64 Darlinghurst, Kings Cross, N.S.W.	16.13	"	"
Martin, William A., Correspondence School, PB, Wellington 1, N.Z.	15.04	"	"
Mason, Harold P. and Dowling Denise M., Flat 2, 63 Kitchener Rd, Ascot, Qld.	14.00	"	"
Mather, Donald J., P.O. Box 50142, Porirua, N.Z.	16.13	"	"
Matthews, Margaret D., 29 Gerald Cl, Burgess Hill, RH15 ONB, U.K.	10.61	"	"
McCarry, Olivine, M., Unit 2, 95 Princes Lane, Newport Beach, N.S.W.	40.32	"	"
McDermott, Hedda M., c/o Julius S. Holt, 9 Lisbuoy Cr, Toorak	10.01	"	"
McDowall, Helen, Berry's Creek Rd, Mirboo North	24.65	"	"
McGinness, John and Mary, P.O. Box 543, Arawa, P.N.G.	42.95	"	"
McGrath, William A., 25 Adrian St, Mackay, Qld.	16.52	"	"
McJannett, Alan H. D., 45 Drumalbyn Rd, Bellevue Hill, N.S.W.	10.26	"	"
McMahon, Dellas, P.O. Box 55, Potts Point, N.S.W.	40.32	"	"
McMann, David, "Longreaves", Lon St. Efraid, Trearddur Bay, Holyhead Anglesey, North Wales, U.K.	14.51	"	"
McNally, Kenneth F., Keravat High School, Rabaul, P.N.G.	16.93	"	"
McNally, Max D., Pattison St, Emu Park, Qld.	55.49	"	"
McNamara, Diann L., 66 Gaffney St, Broken Hill, N.S.W.	23.26	"	"
Meehan, Winifred, 126 Mooney St, Gulliver, Townsville, Qld.	15.78	"	"
Mengel, Joseph T. Jnr., Apart 108, 7200 York Ave, SO, Edina MN 55435, U.S.A.	16.13	"	"
Merrill, Richard (estate of), c/o H. C. Merrill, P.O. Box 180, Elsinore, CA 92330, U.S.A.	25.50	"	"
Milku, Leonard, c/o P.N.G. Forestry Product, P.O. Box 71, Bulolo, P.N.G.	416.82	"	"
Millar, Iain R., 2 John St, Payneham, S.A.	14.51	"	"
Miller, Gary and Nona, P.O. Box 124, Lincoln, New Mexico 88338, U.S.A.	10.75	"	"

Unclaimed Moneys Act 1962

Register of Unclaimed Moneys held by the—

<i>Name of Owner on Books and Last Known Address</i>	<i>Total Amount Due to Owner</i>	<i>Description of Unclaimed Money</i>	<i>Date when Amount first became Payable</i>
\$			
CRA GROUP SHARE REGISTRY— <i>continued</i>			
Miller, Jessie U. (estate of), c/o Colin J. James, 244 Forest Rd, Hurstville, N.S.W.	32.89	Dividend	3.11.83
Mills, Margaret A., 1/13 Sweet St, Mundingburra, Qld.	45.50	"	"
Mitchell, Katrina, Unit 11, 25 Marshall St, Manly, N.S.W.	11.99	"	"
Mitrakos, Christos, 192 Concord Rd, Concord West, N.S.W.	140.00	"	"
Morganstern, Carol J., G.P.O. Box 2737x, Melbourne	21.00	"	"
Muir, Laurence M., Meadow End, Kyla Park, Tuross Head, N.S.W.	34.98	"	"
Muldownie, Dennis J., Post Office, Tom Price, W.A.	19.35	"	"
Mumford, Peter G., P.O. Box 14, Port Vincent, S.A.	22.68	"	"
Murray, Michael F. and Gina A., Westminster School, Marion, S.A.	16.89	"	"
Murray—IV, Thomas F., Unit 1, 128 Forrest St, Peppermint Grove, W.A.	21.51	"	"
National Westminster Bank Nominees, (Jersey) Limited, P.O. Box 11, 16 Library Pl, St. Helier, Jersey, Channel Islands	10.50	"	"
Naylor, Cheryl and Barry, 41 Gregory St, Wembley, W.A.	18.03	"	"
Neo, Koh L., c/o Seagroatt & Campbell, P.O. Box 790, Kuala Lumpur, Malaysia	268.82	"	"
Nicol, Margaret A., P.O. Box 2274, Darwin, N.T.	32.26	"	"
Nicoll, David A., William St, Beaudesert, Qld.	19.99	"	"
N.Z. Refining Nominees Limited, P.O. Box 44, Whangarei, N.Z.	38.25	"	"
O'Brien, Edward J., 6/65 Moray St, New Farm, Qld.	13.25	"	"
O'Keefe, Christine, 15 Brown St, Toowoomba, Qld.	19.35	"	"
O'Neill, Jean (Lt. Col.) Victoria Barracks, Paddington, N.S.W.	140.00	"	"
O'Riordan, Richard A., Unit 1, 120 Stafford Rd, Kedron, Qld.	15.00	"	"
Odvarka, Vera, 35 Wrigley St, Maroochydore, Qld.	35.00	"	"
Olejnik, Stanislaw (Dr.) & Elzbieta D., Flat 1, 14 Maxim St, Ryde West, N.S.W.	16.13	"	"
Orme, Glenys and James, P.O. Box 511, Arawa NSP, P.N.G.	16.13	"	"
Osborne, John S. (estate of) and Henry and Munro, Juliet C., c/o Hordern Utz & Bode, 15-19 Bent St, Sydney, N.S.W.	176.49	"	"
Overseas Nominee Co. Inc., c/o Citibank, N.A., 20 Exchange Pl, New York, NY10043, U.S.A.	15.30	"	"
Pakula, Irena, 20 Need St, Enfield, S.A.	40.32	"	"
Parish, Clement R. W., Walcot Hall, Lydbury, Shropshire, U.K.	21.93	"	"
Patterson, Agnes R., 43 Amanda St, Port Pirie West, S.A.	11.06	"	"
Patterson, Eileen, c/o Supply & Transport, Posts & Tele, P.O. Box 6352, Boroko, P.N.G.	19.35	"	"
Payne, George and Betty J., 61 George St, Mt. Isa, Qld.	35.00	"	"
Pearce, Kevin J., P.O. Box 239, Quirindi, N.S.W.	10.75	"	"
Peck, Nancy J., "Bundara" Old Healesville Rd, Yarra Glen	115.89	"	"
Pegler, Jeffrey R., Post Office, The Monument, Qld.	14.00	"	"
Perrers, Elizabeth, 4 Mona Rd, Woodford, N.S.W.	43.01	"	"
Perrin, Marilyn, Flat 19, 35 Walsh St, South Yarra	15.99	"	"
Perry, Cyril J., 3 Charles St, Abbotsford	25.75	"	"
Petherbridge, Michael B., Flat 2, 70 Ocean Beach Rd, Woy Woy, N.S.W.	16.13	"	"
Phair, George L. and Alice M. (estate of), c/o Norman Shankly & Hamilton, 406 Lonsdale St, Melbourne	17.74	"	"
Philp, John R. M., c/o ANZ Bank Ltd., 290 Pacific Hwy, Crows Nest, N.S.W.	11.07	"	"
Pincus, Caitlin S. J., 43 Laurel Ave, Chelmer, Qld.	21.51	"	"

Unclaimed Moneys Act 1962

Register of Unclaimed Moneys held by the—

Name of Owner on Books and Last Known Address	Total Amount Due to Owner	Description of Unclaimed Money	Date when Amount first became Payable
\$			
CRA GROUP SHARE REGISTRY—continued			
Pitt, Georgia F., 93 Kooyong Koot Rd, Hawthorn	19.35	Dividend	3.11.83
Pitt, Matthew W., 93 Kooyong Koot Rd, Hawthorn	14.51	"	"
Podmore, Linda A., 1 Falcon Pl, Wagga Wagga, N.S.W.	15.08	"	"
Polin, Martin, 1445 Marsh St, San Luis, Obispo CA93401, U.S.A.	26.88	"	"
Prangnell, Garry M., 27A Colombo St, Christchurch 2, N.Z.	10.75	"	"
Preston, Maro, 22 Snowdon Dve, Cheltenham	28.00	"	"
Puehringer, Franz X., 10 Kinglake Rd, Whittlesea	63.43	"	"
Quinn, Victoria A., 260 Bridge Rd, Glebe, N.S.W.	53.35	"	"
Ralph, Richard S. C., P.O. Box 1004 Katherine St, N.T.	31.44	"	"
Randell, John F., P.O. Box 31000, Lusaka, Zambia	18.90	"	"
Ratcliffe, Lillian V., 16 Victor St, Beaumaris	13.33	"	"
Read, Peter H., c/o Laura Johnson Home, MT. Isa, Qld.	14.00	"	"
Reno, Charles, 709 Barning Tree La, Naperville, Illinois, 60540, U.S.A.	16.13	"	"
Rigney, Scot, 5 Mayfair St, Mt. Claremont, W.A.	24.15	"	"
Roberts, David W., and Eileen G. R., 14 Vicarage Fields, Ruabon, Wrexham Clwyd, U.K.	16.13	"	"
Robertson, Graham, Flat 3, 32 SMQ, Tom Price, W.A.	13.44	"	"
Robins, Adelaide and Guth, S., c/o Wise Speke & Co., 103 Albert Rd, Middlesbrough TS1 2PA, U.K.	13.59	"	"
Robinson, Sidney H., P.O. Box 45, Avalon Beach, N.S.W.	63.99	"	"
Rollo, Helen L., 203 Domain Rd, South Yarra	11.05	"	"
Roper, Rita, P.O. Box 1131 Townsville, Qld	13.14	"	"
Rose, Dulcie C., 12 Kirkham St, Beecroft, N.S.W.	59.53	"	"
Ross, William J., c/o Suzanne's Silks, 145-149 Dorcas St, South Melbourne	107.53	"	"
Rothlisberger, Max, Nussweg 11, 4852, Rothrist, Switzerland	16.13	"	"
Rudd, Margaret, Flat 9/201 Lake St, Cairns, Qld	32.26	"	"
Ryott, Rome S., 1 East Hill, Lymington, Hants, U.K.	15.30	"	"
Sampson, Mary K., 19 Jean St, McKinnon	193.55	"	"
Sandara Pty. Ltd, c/o Cameron Sloan & McDowall, 4 Bligh St, Sydney, N.S.W.	70.00	"	"
Sanderson, John S., 7 De Beauvoir Square, London, N1, U.K.	12.75	"	"
Sanderson, Theonilla G., 4 Doubell Close, Glen Waverley	19.35	"	"
Sarea, Simeon, c/o Tivilis, Leon Village Post Office, Kavieng, P.N.G.	11.39	"	"
Sawicki, Jerzy, 43 Hester Way, Greenwood, W.A.	11.06	"	"
Sawoff, Irene, 54 Alexandra St, South Yarra	72.58	"	"
Scanlon, Margaret C., 12 Monterey St, Wacol, Qld	35.00	"	"
Schneider, Max C., 31 Tingi Ave, Slacks Creek, Qld	19.35	"	"
Scott, Patricia, 5 Windamere Grve, Churton Park, Wellington, N.Z.	19.75	"	"
Scott-Roberts, Fiona, c/o Carr Sebag, Ocean House, 10/12 Little Trinity Ln, London EC4P 4LB, U.K.	16.06	"	"
Scouller, George H., 5 Clare St, Boggabri, N.S.W.	21.51	"	"
Chee, Seck W., 25 Jalan Unggas, Singapore 1129, Singapore	27.20	"	"
Sedgley, Lydia M., "Warren Park" Hallam Rd, Narre Warren North	24.32	"	"
Seeto, Agnes, Kan Hee Seeto & Sons, P.O. Box 97, Rabaul, P.N.G.	19.35	"	"
Seeto, Jenny L. K., 374 Capalaba Rd, M1 Gravatt, Qld	19.35	"	"
Seeto, Richard and Wendy, Flat 1 4/10 Darling St, Kensington, N.S.W.	38.71	"	"
Seeto, Thomas W. S., P.O. Box 41, Lae, P.N.G.	19.35	"	"
Sekiguchi, Koyo, c/o Mitsubishi Corp, 6-3 Marunouchi 2-Chome Chiyoda-Ku, Tokyo, Japan	12.75	"	"
Setu, Ami C., P.O. Box 62, Emerald, Qld	21.42	"	"

Unclaimed Moneys Act 1962

Register of Unclaimed Moneys held by the—

Name of Owner on Books and Last Known Address	Total Amount Due to Owner	Description of Unclaimed Money	Date when Amount first became Payable
\$			
CRA GROUP SHARE REGISTRY—continued			
Sheehan, Vicki L. and Debbie Lee-Anne., Campbell's Creek	11.49	Dividend	3.11.83
Simpson, Marie, 56 Balgownie Rd, Balgownie, N.S.W.	10.21	"	"
Simpson, Warwick Emslie, Clarksville, Milton Rd, 2 Otago, N.Z.	19.35	"	"
Sismey, Stanley F., 40 Fossey St, Holder, ACT	11.61	"	"
Skurlow, Adela, 5 Cooper St, Strathfield, N.S.W.	80.65	"	"
Smith, Janet C., 5 Blythswood Cres, Largs, Ayrshire, U.K.	16.21	"	"
Smith Walter P., 11 Charles St, Ryde, N.S.W.	350.00	"	"
Sobieska Pty. Ltd., P.O. Box 75 Carlton South	96.77	"	"
Soetens, Nettie, P.O. Box 551, Brookvale, N.S.W.	14.00	"	"
Soh, Cecilia M., 30 Marie St, Dudley Park, Mandurah, W.A.	25.65	"	"
Spring, James, Flat 5, 28 Bland St, Ashfield, N.S.W.	35.00	"	"
Squire, William J., P.O. Box 110 Panguna, P.N.G.	35.37	"	"
Stanley, Isabelle M. and Patel, Yvonne V., 12 Binjai Walk, Singapore 21, Singapore	12.15	"	"
Stephen, Ernest A. and Dorothy J., South West Highway, Donnybrook, W.A.	35.00	"	"
Stephens, Donald G., Lot 4, Nyari Rd, Kenhurst, N.S.W.	19.35	"	"
Sterrett, Ronald W., Esplanade Dohles Rocks Rd, Griffin, Qld	19.34	"	"
Stokes, Lawrence, 15 Sorrett Ave, Malvern	95.52	"	"
Strachan, Richard G., c/o National Westminster Bank Ltd., 108 Whiteladies Rd, Bristol, B58 2QZ, U.K.	10.20	"	"
Street, Charles, P.O. Box 5614, Boroko, P.N.G.	19.35	"	"
Tacheci, Vicki A., P.O. Box 380, Canberra City, A.C.T.	14.00	"	"
Tamblyn, Helen E., 15 Bickford Tee, Somerton Park, S.A.	132.99	"	"
Cheng, Tang T., 284 Simpang Tiga, Sungai Siput (North), Perak, Malaysia	32.26	"	"
Taylor, Jill, Firs Farm House, Hoton, Loughborough Leicester, U.K.	15.68	"	"
Thomas, Basil P. B., Lower Oakshott, Hawkey, Liss, Hants GU33 6LP, U.K.	96.77	"	"
Thompson, Kathleen L. and Richard L., Newnhams Cottage, Maresfield, Sussex, U.K.	23.56	"	"
Thompson, Alfred J.M., "The Old Music Room" Monkey Island Lane, Bray, Berkshire, U.K.	30.60	"	"
Thorn, Cedric B. and Swales, Harry D. and Thorn Maureen P., S G 2 A/C Trees, Stubbs Wood, Chesham Bois, Amersham, Bucks, U.K.	96.77	"	"
Tobin, Barry A., 202 Illawarra Rd, Helensburgh, N.S.W.	11.99	"	"
Torrens, Mary S., Braidujle, House, Drumbo, Lisborn, Co Antrim, N. Ireland	13.08	"	"
Trentham Pty. Ltd., Flat 5, 2 Mona Vale Rd, Pymble, N.S.W.	977.42	"	"
Trinity College of Music, London, 11 Mandeville Pl, London W1M 6AQ, U.K.	20.40	"	"
Trinkey Pastoral Co. Pty. Ltd., c/o G. H. Anderson & Co., Wingello Hse, Angel Pl, Sydney, N.S.W.	67.17	"	"
Truall Nominees Pty. Ltd., Room 501, 16 O'Connell St, Sydney, N.S.W.	106.08	"	"
Turner, Archie, C., 229 Owen Bve, Willowdale Ontario, Canada	96.77	"	"
Olveling, Henriette, c/o Dr N. Packham, 217 Cleveland St, Redfern, N.S.W.	70.00	"	"
Umeda, Akira, c/o B. L. Davey, Comalco Ltd., 95 Collins St, Melbourne	11.50	"	"
Van Vyve, Francois, Frankrijklei 107, B-2000 Antwerpen, Belgium	12.53	"	"
Vines, Sir William, 73 Yarranabbe Rd, Darling Point, N.S.W.	32.01	"	"
Virgin, James T., 10 Park Cres, Caulfield	14.00	"	"

Unclaimed Moneys Act 1962

Register of Unclaimed Moneys held by the—

<i>Name of Owner on Books and Last Known Address</i>	<i>Total Amount Due to Owner</i>	<i>Description of Unclaimed Money</i>	<i>Date when Amount first became Payable</i>
\$			
CRA GROUP SHARE REGISTRY—continued			
Wainwright, Eugene K., 185 Buffalo Rd, Ryde, N.S.W.	10.47	Dividend	3.11.83
Waldron, Olwyn G., 11 Gatenby St, Condobolin, N.S.W.	38.71	"	"
Ward, Adrian G., P.O. Box 84, Rabaul, P.N.G.	107.53	"	"
Ward, Petrah, P.O. Box 84 Rabaul, P.N.G.	107.53	"	"
Warringah Theatres Pty. Ltd., P.O. Box 45, Avalon Beach, N.S.W.	32.01	"	"
Wells, Clifford and Margaret A., P.O. Box 2281, Lae, P.N.G.	12.75	"	"
Whitford Investments Pty. Ltd., c/o Deloitte Haskins & Sells, G.P.O. Box L889, Perth, W.A.	147.42	"	"
Wightman, Ronald W., P.O. Box 1343, Palmerston North, N.Z.	135.48	"	"
Wilks, Lisbeth A., and Tighe, Annabelle H., 118 Greenhill Rd, Grensborough	37.16	"	"
Williams, Christine I., Swallow St, Slade Point, Qld.	14.03	"	"
Williams, John, Hesworth, Fittleworth, Pulborough, Sussex, U.K.	98.99	"	"
Williams, Lesley M., 2 Gunn St, Eudunda, S.A.	14.33	"	"
Williams Valda, 14 Churchill Rd, Cockle Bay, N.Z.	16.13	"	"
Willis, John D., 130 Victoria Ave, Palmerston North, N.Z.	16.75	"	"
Willson, Beverley I., P.O. Box 253, Gisborne, N.Z.	36.38	"	"
Wong, Denis, 18 Campbell St, Sydney, N.S.W.	35.00	"	"
Wong, James S., P.O. Box 4098, Badili, Port Moresby, P.N.G.	19.35	"	"
Wood, Barrie J., Okahu Road, RD 1, Kaitaia, N.Z.	19.35	"	"
Wren, Kathleen R., Residence No. 2, Balimo, P.N.G.	19.35	"	"
Wright David, P.O. Box 2258, Darwin, N.T.	12.58	"	"
Wright, John M. and Park, John M., Newton House, St., Margarets, Dublin, Eire	10.16	"	"
Yag Holdings Pty. Ltd., 55 Hallam Belgrave Rd, Belgrave	15.00	"	"
Yager, Susan J., 12 Albany St, Gosford, N.S.W.	16.13	"	"
Yarwood, Arthur (estate of), c/o Dean & Co., 62 Hagley Rd, Stourbridge DY8 1QD, U.K.	30.19	"	"
Yelland, Simon R., c/o L. C. Yelland, 10 River Cres, Cypress Gardens, PS2107, Qld.	19.35	"	"
Yen, Madam H. and Sew K., Conzinc Rio Tinto, Malaysia SDN BHD, P.O. Box 202, Dengkil, Kajang, Selangor, Malaysia	19.35	"	"
Chong, Yeow F., 38 Conway Dr, Singapore 1955, Singapore	80.65	"	"
Zaleski, Leonard, 19 Poplar Plains Rd, Toronto, Ontario, Canada	80.65	"	"
Ziesing, Peter R., P.O. Box 776, Port Moresby, P.N.G. 7451	19.35	"	"
RALPH McKAY LIMITED			
Blackman, Grant R., Blackmans, Meryl A. and Pollock, Pamela M., 130 Faraday St, Carlton	98.40	Interest	25.3.83
Galvin, Iuy P., 89 Blyth St, Brunswick	32.24	"	"
Griffiths, Mollie (estate of), c/o Russell J. Bainton, 174 Phillip St, Sydney, N.S.W.	28.80	"	30.9.83
Johnson's Pty. Ltd., c/o Watt Mallet & Co., 276 Waverley Rd, East Malvern	480.00	"	25.3.83
Love, Richard, 34 Cecil St, Gordon, N.S.W.	13.76	"	"
MacPherson, Alexander M. (estate of), 40 Galibal St, Waramanga, A.C.T.	138.24	"	"
MacPherson, Carrie A., 40 Galibal St, Waramanga, A.C.T.	27.60	"	"
Richards, Phyllis J. (estate of), 20 Howard St, Glen Iris 7445.	27.60	"	"

Unclaimed Moneys Act 1962

Register of Unclaimed Moneys held by the—

<i>Name of Owner on Books and Last Known Address</i>	<i>Total Amount Due to Owner</i>	<i>Description of Unclaimed Money</i>	<i>Date when Amount first became Payable</i>
\$			
FORD MOTOR CO. OF AUST. LTD. (INCORPORATED IN VIC.)			
Assaad, Y., 55 Elliot St, Reservoir	38.38	Wages	14.3.83
Abdulrahin, N., 1/126 Albion St, Brunswick	162.56	"	20.9.82
Brkic, I., 75 Hope St, Brunswick	153.15	"	13.2.84
Cakici, S., 11 Jessie St, Coburg	46.48	"	13.6.82
Dervish, 15 Kellaway Rd, Glenroy	34.19	"	31.10.83
Dervish, 15 Kellaway Rd, Glenroy	45.28	"	7.11.83
Huynh, V. T., 3/97 Eastwood St, Kensington	210.72	"	1.8.83
Kilickaya, I., 35 Victoria Dve, Thomastown	24.88	"	7.11.83
Kronic, R., 5 Byrnei Crt, Cambellfield	33.31	"	"
Kumas, A., 3/55 De Carle St, Brunswick	33.31	"	"
Keith, D., 1 Unit Crt, Broadmeadows	94.59	"	27.2.84
Limberopoulos, A., 13 Alderbrook Ave, Mulgrave	25.41	"	12.12.83
Mathios, F., 14 Thackeray Rd, Reservoir	11.93	"	22.8.83
Pierce, W., 83 Phillips St, Coburg	84.97	26.12.83	"
Tong, Pao, 11 Walsh St, Preston	46.51	"	7.11.83
Daoud, M., 18/76 Edward St, Brunswick	164.35	"	26.12.83
Hanna, M., 185 Stewart St, Brunswick	64.03	"	"
Tekir, Y., 9/93 Tinning St, Brunswick	40.81	"	30.1.84
Daoud, M., 18/76 Edward St, Brunswick	98.08	"	6.2.84
Tataroglo, E., 4 Erin Crt, Coolaroo	627.00	"	"
7446			
A.C.I. AUSTRALIA LIMITED			
The Child Safety Campaign of Australia	200.00	Donation	1.12.83
7447			
THE BRITISH PETROLEUM COMPANY OF AUSTRALIA LIMITED			
Gubbay, Marthe S., 72 Bay Rd, Blue Bay, The Entrance, N.S.W.	100.00	Debenture	28.3.83
Jeffrey, Annette M., 3 Callantine Rd, Hawthorn	107.50	"	28.2.83
Knewstubb, Mary E., 25 Canterbury Rd, Montrose	127.50	"	"
Park, Margot M. W., 60 St. Vincents Pl, Albert Park	53.75	"	"
Quinn, Mary, c/o Septimus Jones & Lee, 257 Collins St, Melbourne	82.50	"	"
Room, Ross H., 16 Scott Gve	268.75	"	31.8.83
Simpson, Catherine S., 288 Morrison Rd, Ryde, N.S.W.	53.75	"	"
Valmar Superannuation Fund Inc. P.O. Box 387, Elizabeth, S.A.	55.00	"	28.2.83
7683			
AUC HOLDINGS LIMITED			
Shankly, Eliza A. D., Norman S. and Roy B., c/o Shankly & Shankly, 406 Lonsdale St, Melbourne	11.00	Dividend	16.3.81
Shankly, Norman J. (estate of), c/o N. J. Shankly & Shankly, 406 Lonsdale St, Melbourne	13.75	"	"
Shankly, Eliza A. D., Norman S. and Roy B., c/o N. J. Shankly & Shankly, 406 Lonsdale St, Melbourne	15.40	"	19.10.81
Shankly, Norman J. (estate of), c/o N. J. Shankly & Shankly, 406 Lonsdale St, Melbourne	19.35	"	"
7685			

Unclaimed Moneys Act 1962

Register of Unclaimed Moneys held by the—

<i>Name of Owner on Books and Last Known Address</i>	<i>Total Amount Due to Owner</i>	<i>Description of Unclaimed Money</i>	<i>Date when Amount first became Payable</i>
\$			
PETERSVILLE SLEIGH LIMITED			
Aitken, Elizabeth H., 5 Daphne St, Canterbury	10.00	Dividend	31.10.83
Anderson, Alan K., 339 Somerville Rd, West Footscray	25.00	"	"
Attkins, Roy J. (estate of), c/o Corr & Corr, 290 Latrobe St, Melbourne	120.00	"	"
Austin, John C. M., 12 Cobbadan St, Jindalee, Qld.	30.00	"	"
Balwagowan, Jessie M. E., Kings Rd, Moss Vale, N.S.W.	90.50	"	"
Barnett, Edin K., Bethllhem, RD 1 Tauranga, N.Z.	10.63	"	"
Barr-Brown, Allan J., Route 6 Box 510, Lakeland, Florida 33801, U.S.A.	98.43	"	"
Barry, Jeffrey (estate of), 113 Studley Rd, Heidelberg	40.00	"	"
Barry, Peter R., 119 Shelford Rd, Radcliffe on Trent, Nottingham, NG12 1AZ, U.K.	76.50	"	"
Baxter, Maisie, P.O. Box 155, Mackay West, Qld.	70.00	"	"
Bayston, Nora T. (estate of), c/o McCracken & McCracken, 414 Collins St, Melbourne	58.30	"	"
Beasley, John L. and Lynette K.,	13.00	"	"
Beazley, Gladys, 57/1 Selway St, Oaklands Park, S.A.	10.00	"	"
Black, David C. M. (estate of), c/o Whatmore Gee & Co., 20 Bridge St, Sydney, N.S.W.	40.00	"	"
Bloxham, Jean M., 5/36 Davidson St, Richmond	10.00	"	"
Bowen, Barry W., 281 Drummond St, Carlton	100.00	"	"
Bowman, Eleanor, 433 Hector St, Yokine, W.A.	11.60	"	"
Brett, Vincent L., 634 Jesmond Rd, Fig Tree Pocket, Qld.	10.00	"	"
Broadbent, Frederick V., 13 Lackey St, Haymarket, N.S.W.	20.00	"	"
Brown, Lindsay C., 5/347 Annadale St, Annadall, N.S.W.	11.60	"	"
Bucholtz, Leonard, 10 Jessie St, Westmead, N.S.W.	78.60	"	"
Bucholtz, Leonard and Ruth E. B., 10 Jessie St, Westmead, N.S.W.	70.00	"	"
Bunton, Robert F., P.O. Box 41, Hampton	20.00	"	"
Burns, John, 112 Mt. Pleasant Rd, Belmont	50.00	"	"
Buzolick, Wendy, Wenden Crt, Warrnambool	26.00	"	"
Byrne, Margaret C., 24 Raglan St, South Ballarat	40.00	"	"
Cameron, Alexander K., P.O. Box 291, Roma, Qld.	25.00	"	"
Carder, John A. H., Wicket Hill Wrecclesham, Nr Farnham, Surrey, U.K.	99.11	"	"
Carey, Raymond G., P.O. Box 612, Shepparton	15.50	"	"
Chan, Madam Teng N., c/o G. K. Goh Securities Pte, 1201 A Bangkok Bank Building, Cecil St, Singapore	198.31	"	"
Charlton, Gary, 1 Paris Plc, Miranda, N.S.W.	10.00	"	"
Chia, Siak K., c/o Thomas Lim, 4 Mulea Pl, Duncraig, W.A.	23.30	"	"
Churchill, Clarice A., 10 Monash Ave, Como, W.A.	48.40	"	"
Coleman, Marcelle Y., 2/117 Pembroke St, Coor Paroo, Qld.	60.00	"	"
Cotsicos, Nicole E., 10 Byrne Ave, South Coogee, N.S.W.	40.00	"	"
Cox, Geoffrey D., 2 Rudd St, North Ryde, N.S.W.	50.00	"	"
Cusack, Kevin T., P.O. Box 237, Damaru, N.Z.	17.00	"	"
Dalton, Anne P., 40 Rickard Ave, Mosman, N.S.W.	30.00	"	"
Dalton, Robert B., 64 McNeily Rd, Drouin	39.50	"	"
Davies, Kevin M., 15 Telemon St, Beavdesert, Qld.	23.30	"	"
Champion De Crespigny, Philip H., 2nd Floor, 44 Caroline St, South Yarra	10.00	"	"
Dixon, James N., c/o Commonwealth Trading Bank, 505 Collins St, Melbourne	10.00	"	"
Dockett, Virginia A., c/o Post Office, Yarwin, Qld.	50.00	"	"
Dohnt, Peter, 61 Penzance St, Glenelg, S.A.	20.00	"	"

Unclaimed Moneys Act 1962

Register of Unclaimed Moneys held by the—

<i>Name of Owner on Books and Last Known Address</i>	<i>Total Amount Due to Owner</i>	<i>Description of Unclaimed Money</i>	<i>Date when Amount first became Payable</i>
\$			
PETERSVILLE SLEIGH LIMITED—continued			
Donaldson, Thomas, Schoolhouse, Inch Down, Patrick Down, Eire	42.00	Dividend	31.10.83
Donkin, Rex O., c/o Golden Fleece Service Station, Koorlingal, N.S.W.	10.00	"	"
Dowling, Geoffrey A., 17 Albury Rd, North Balwyn	40.00	"	"
Dowling, Kyran F., 20b Jennings St, Sandringham	30.00	"	"
Duff, Diana, 5 Kerferd Rd, Hampton	10.00	"	"
Dunn, Cheryl A., 2 Tyrol Crt, Doncaster East	20.00	"	"
Edson, Stephen, and Stralia, 17 Albert St, Wagga Wagga, N.S.W.	50.00	"	"
Johnson, Peter F. (estate of), c/o Adamson & Kyle, P.O. Box 742, Southport, Qld.	20.00	"	"
Jordan, Jennifer,	10.00	"	"
Joseph, Max R.,	10.00	"	"
Kahn, Diana, c/o M. G. K. Consolidated P/L, P.O. Box 476, Richmond	58.30	"	"
Kalowski, Henrik, 29 Beresford Rd, Rose Bay, N.S.W.	30.00	"	"
Kelly, Katherine, Corringale, Rugby via Crookwell, N.S.W.	10.00	"	"
Kenny, Gertrude M. (estate of), c/o D. Scott, 106 Katrina St, Blackburn North	50.00	"	"
Krauss, Laurie L., 88 St, Helens Rd, Hawthorn East	50.00	"	"
Krieg, Barbara K., 2/5 Edward St, Bondi, N.S.W.	20.00	"	"
Krutli, Leslie N., P.O. Box 1, Yachandandah	12.50	"	"
Kube, Thelma A., Flat 5, St. Margarets, 100 Toorak Road West, South Yarra	32.00	"	"
Lancaster, Peter G., 9 Steinwedel St, Farrer, A.C.T.	193.00	"	"
Lees, William D., P.O. Box 97, Lac, P.N.G.	24.65	"	"
Lesbirel, Eric, 19 Myrtle St, South Yarra	23.30	"	"
Leslie, Margaret F. (estate of), c/o Wonderley & Hall, P.O. Box 838, Toowoomba, Qld.	20.00	"	"
Lever, Mary A., 27 Union St, Paddington, N.S.W.	11.00	"	"
Liste, Ross M., Rowbotham St, Middle Ridge, Qld.	11.60	"	"
Lithgow, Donald J. and Halse, Helen V. A., c/o 3 Zetland Rd, Mont Albert	40.00	"	"
Logan, Margery A., Unit 1, 16 Thomas St, Ringwood	23.30	"	"
Longfield, Francis A., 84 Robinson Rd, Hawthorn	50.00	"	"
Lynn, Julian C., c/o "Waireka", TeMoana Geraldine, N.Z.	25.50	"	"
M. F. Star Holdings Pty. Ltd., c/o M. F. Star, Star Bros. Pty. Ltd., 654 King St, Newtown, N.S.W.	11.00	"	"
Mackie, Doreen, 21 Bundinla Ave, Mount Riverview, N.S.W.	140.00	"	"
Mahar, Heather M., 77 Longview Rd, Croydon	20.00	"	"
Maher, Terence P. and Agnes J., P.O. Box 55, Campbelltown, S.A.	11.60	"	"
Maillard, John S. and Nancy H., 2 Huntingdale Ave, Beverly Hills, N.S.W.	30.00	"	"
Majaris, Nessie,	10.30	"	"
Marshall, William H., 90 Spofforth St, Cremorne, N.S.W.	10.00	"	"
Martin, David J., 20 Athelstane Ave, Arncliffe, N.S.W.	25.00	"	"
McCormack, Sadie I., 90 Ruskin St, Elwood	20.00	"	"
McCullock, Edward J., RD 3 Whakatane, N.Z.	19.81	"	"
McCullock, Janice E., 52 Thorn St, Pennant Hills, N.S.W.	18.90	"	"
McDonald, Thelma G., 7/16 Maple Gve, Toorak	50.00	"	"
McDougall, Graeme V., 54 New South Head Rd, Vaucluse, N.S.W.	23.50	"	"
McVean, Gavin A., 4 Yarral Ave, Tamworth, N.S.W.	20.00	"	"
McVitty, Grace R., 4 Chapman St, East Brighton	21.00	"	"
Membrey, John W. and Bryan and Thompson, Colin R., 1 Ithaca St, Frankston	50.00	"	"

Unclaimed Moneys Act 1962

Register of Unclaimed Moneys held by the—

Name of Owner on Books and Last Known Address	Total Amount Due to Owner	Description of Unclaimed Money	Date when Amount first became Payable
§			
PETERSVILLE SLEIGH LIMITED—continued			
Mills, Warren F. and Callahan, Peter J., 208 Jasper Rd, Bentleigh	163.10	Dividend	31.10.83
Mooney, Jean,	10.00	"	"
Morton, Kenneth M., 53 Nelson St, Eaglehawk	30.00	"	"
Munnerley, Keith B., 51 Well St, Brighton	10.00	"	"
Murakami, Hiroshi, 930-64 Fueta Kamakura, Kanagawa Prefecture, Japan	17.00	"	"
Murphy, Allan, 18 Newland Pl, Engadine, N.S.W.	20.00	"	"
Murray, Doris I., 194 George St, East Melbourne	50.00	"	"
Myers, Noel F., 10 Heath St, Auburn, N.S.W.	20.00	"	"
Nance-Kivell, Gregory, Prince Alfred St, Berry, N.S.W.	10.00	"	"
Napier-Clavering, Maud M., c/o Wilkinson Marshall Clayton, 3rd Floor, 27 Grainger St, Newcastle-Upon-Tyne, NE1 5JY, U.K.	170.00	"	"
Napruka Investments Pty., 501 Military Rd, Largs Bay, S.A.	400.00	"	"
Neville, Reginald F., 2/67 Wattle Valley Rd, Canterbury	70.00	"	"
Nicholls, Litette A., G.P.O. Box 1766, Sydney, N.S.W.	11.60	"	"
Parkin, Peter H., Athol White Court, Tocumwal, N.S.W.	40.00	"	"
Pavy, Dr Ian G., 2 College St, College Park, S.A.	26.00	"	30.9.83
Peffer, Barry A. and Chery D., 26 Fitzroy St, Abbotsford, N.S.W.	58.30	"	31.10.83
Pennycuik, William B., c/o Pennycuik & Co. Pty. Ltd., 2 York St, South Melbourne	233.30	"	"
Pickering, Barbara F., c/o R. J. Winten, 3 Highview Crt, Toowoomba, Qld.	10.00	"	"
Podbury, Murray B., 5 Vanessa Crt, Frankston	19.00	"	"
Pokorny, Dorothy,	10.00	"	"
Pollitt, Joyce V., Flat 7, 4 Bendigo St, Richmond	10.00	"	"
Pollock, Jeffrey N. (estate of) and Tarrant, Phillip J., c/o W. J. Nelson, 199 Pound St, Grafton, N.S.W.	10.00	"	"
Powell, Emmett E. (estate of), c/o 1A Ludgate St, Lakemba, N.S.W.	12.50	"	"
R. A. & Y. G. Flockhart Pty. Ltd., 319 Coronation Dve, Milton, Qld.	16.50	"	"
Rado, Peter F., 3/8 Murray St, Lange Cove, N.S.W.	90.00	"	"
Raisbeck, Phyllis C., 5 Shrimpton Crt, Mont Albert	30.00	"	"
Ramplin, Desmond F., P.O. Box 105, Taree, N.S.W.	40.00	"	"
Rich, Rhonda E., 18 Lambert Ave, Lower Sandy Bay, Tas.	40.00	"	"
Richards, Timothy T.,	10.00	"	"
Roberts, Ben, 22 Nagle St, Upper Mt. Gravatt, Qld.	16.50	"	"
Roche, Peter J., c/o Workers Compensation Board, G.P.O. Box 2459, Brisbane, Qld.	10.00	"	"
Rushworth, Roy B., 113 Brighton St, Petersham, N.S.W.	20.00	"	"
Ryan, Thomas H., 32 Esperance St, East Victoria Park, W.A.	18.10	"	"
Sangha, Janet, 2/15 Ridge St, Northgate, Qld.	10.00	"	"
Scotus, Peter J., 831 Ballarat Rd, Deer Park	31.10	"	"
Shue, Mary I., 7 Cornelius St, Dandenong	10.00	"	"
Sinclair, Doris E., P.O. Box 96, Port Macquarie, N.S.W.	10.00	"	"
Sinner, Lorraine C., 56 Magnolia St, Lower Templestowe	16.50	"	"
Skinner, Edward T., 8 Kanbara St, Flinders Park, S.A.	10.00	"	"
Smith, Gerald J., 14c Queens Dve, Dunedin, N.Z.	51.00	"	"
Smith, Ian B., 7 Balmoral Plc, Carlingford, N.S.W.	28.40	"	"
Smith, Joan A.,	10.00	"	"
Smith, Raymond L.,	50.00	"	"
Spickelmier, Howard, 1802 West Cherokee, Enid Oklahoma, U.S.A.	42.50	"	"
Stanley, Dr. Oscar T. and Dalia,	10.00	"	"

Unclaimed Moneys Act 1962

Register of Unclaimed Moneys held by the—

<i>Name of Owner on Books and Last Known Address</i>	<i>Total Amount Due to Owner</i>	<i>Description of Unclaimed Money</i>	<i>Date when Amount first became Payable</i>
--	--	---	--

\$

PETERSVILLE SLEIGH LIMITED—*continued*

Stavroff, Sylva M., 13 Bunton St, Scarborough, Qld.	10.00	Dividend	31.10.83
Stevens, Janice F., 4 Seaview Cres, Salamander Bay, N.S.W.	14.10	"	"
Strachan, Winifred E., c/o A. G. Chambers, P.O. Box 76, Camberwell	60.00	"	"
Tay, Denis, c/o G. K. Goh Securities Pte, 1201 A Bangkok Bank Building, Cecil St, Singapore	198.31	"	"
Taylor, Paul D., 24 Delasala Ave, Cardiff, N.S.W.	23.30	"	"
Taylor, Susan, 118 Cross Rd, Highgate, S.A.	10.00	"	"
Thomson, John,	20.00	"	"
Thon, Harry, c/o W. S. Gaston, 1/10 Leicester Ave, Mt. Eliza	23.30	"	"
Thorogood, Peter J., 4 Bertel Plc, Chapman, N.S.W.	23.30	"	"
Triscott, Madeleine T. and James A., 120 Cochrane St, Red Hill, Qld.	20.00	"	"
Van Den Hout, Leander N., 257 Mowbray Rd, Chatswood, N.S.W.	21.30	"	"
Van Hulst, Margery L., 2 Hunt St, Glenbrook, N.S.W.	23.30	"	"
Vigar, Leonard W. S., Bridgewater, S.A.	10.00	"	"
Waldron, Jack G., 463 High St, Kew	60.00	"	"
Ward, Amelia B., c/o Lumeah Elderly Cit's Home, 78 Bruce St, Preston West	40.00	"	"
Watson, Kenneth H., 68/77 Cook Rd, Centennial Park, N.S.W.	33.30	"	"
Webber, Alan G., Keona St, Everton Park, Qld.	40.00	"	"
Weinberg, Lily, c/o A. Kornhauser, 27 Balacava Rd, East St. Kilda	10.00	"	"
Weller, Wayne G., c/o C. Cooper, 10 Brigalow Way, Armadale, W.A.	11.60	"	"
Wells, Raymond H. and John D., c/o J. D. Wells, Franklin Rd, West Pennant Hills, N.S.W.	20.00	"	"
Whittingham, Sidney T., c/o Mr and Mrs O'Shea, 366 Bronte Rd, Bronte, N.S.W.	103.00	"	"
Wilson, Oswin A., Mine range, Mount Morgan, Qld.	11.30	"	"
Witty, Hedly J. J. (estate of), c/o Farmers Trustee, G.P.O. Box 3654, Adelaide, S.A.	51.06	"	30.9.83
Berylwood, Patricia, P.O. Box 9, Blackburn South	270.00	"	31.10.83
Woolley, Thomas H. and Kathleen A., P.O. Box 1104, Launceston, Tas.	10.00	"	"
Yap, Kim C., 18 Road, 7 Eng Ann Estate, Klong Selangor, Malaysia	17.00	"	"
Yuill, Colin K., 2/2 The Close, Hunters Hill, N.S.W. 7597	130.00	"	"

DUNLOP OLYMPIC LIMITED

Stuart, Iain M., P.O. Box 7, Heidelberg	21.38	Debenture	31.5.83
Dalby, William F. C., 4/26 Golf Links Ave, Oakleigh	19.38	"	31.7.83
Gutteridge, Frank G., 35 Studley Rd, East Brighton	27.13	"	"
Lane, Percy F. E., Unit 2, Susan St, 70 Ayton Ave, Fulham, S.A.	58.13	"	"
Lee, Janet W., 25 Clarendon St, Dromana	37.50	"	"
Syme, David M., 16 Tollington Ave, East Malvern	116.25	"	"
Grant, James C., 14 Anderson Ave, Ashgrove, Qld	142.50	"	30.11.83
Johnson, Bradley D., 24 O'Connell St, Kangaroo Point, Qld 7732	71.25	"	"

A. R. C. INDUSTRIES LIMITED

Wheeldon, William J., Gruber County, Clifton Mail, Wagga Wagga, N.S.W. 7600	82.50	Interest	31.12.83
--	-------	----------	----------

Unclaimed Moneys Act 1962

Register of Unclaimed Moneys held by the—

<i>Name of Owner on Books and Last Known Address</i>	<i>Total Amount Due to Owner</i>	<i>Description of Unclaimed Money</i>	<i>Date when Amount first became Payable</i>
§			
G. J. COLES & COY. LIMITED			
Raptis, Theo, 85 Bendigo St, Prahran	324.50	Holiday Pay	1.12.82
Burford, Richard, 166 Koroit Creek Rd, Williamstown	140.70	"	5.11.82
Flacco, Maryanne, 138 Haughton Rd, Huntingdale	18.75	"	25.10.82
Geilen, Stephaine, 8 Suspension St, Ardeer	129.34	"	5.9.83
Robertson, Tracey, 98 Ernest St, Bell Post Hill, Geelong	24.72	Wages	9.9.83
Woodall, Sandie F., Icheviot Close, Wantirna	24.18	"	4.1.84
Congues, Rhonda, 22 Grenthorne Dr, Keysborough	25.67	"	24.12.83
Christidis, Peter, 4/11 Grant St, Clifton Hill	100.32	"	24.2.84
Malusa, Michael, c/o Coles New World Supermarket, Collingwood	20.00	Savings Fund	10.12.82
McDonnell, Clifford, c/o Coles New World Supermarket, Chirnside	40.00	"	27.1.82
McAskell, Dianne, c/o Coles New World Supermarket, Malvern	20.00	"	20.12.83
Jordan, Chris, c/o Coles New World Supermarket, Devonport, Tas.	40.00	"	3.6.81
Edwards, Mariette, c/o G. J. Coles & Coy. Limited, G.P.O. Box 1698P, Melbourne	20.00	"	7.6.83
Atwell, Anne, c/o G. J. Coles and Coy. Limited, G.P.O. Box 1698P Melbourne	20.00	"	19.12.83
Beacher, Richard E., c/o Coles Variety Store, Doncaster	10.00	"	9.6.83
Tubb, Lesley E., Albert Rd, Chiltern	50.00	"	25.1.81
Clarke, Sandra L., c/o K mart, Belmont, Geelong	80.00	"	20.12.83
Vesta, Mary L., c/o Coles New World Supermarket, Mitcham	60.00	"	15.12.82
Dunlop, Patricia, 3 Carey Pl, Traralgon	60.00	"	20.12.83
Molloy, David J., c/o Coles Variety Store, Camberwell	10.00	"	17.7.82
Obudzinski, Kay, c/o Coles New World Supermarket, Albury, N.S.W.	10.00	"	20.12.83
Pappas, Ralph, c/o Melb. Fruit & Veg. Dist. Centre, Sunshine	20.00	"	14.6.83
Potter, Linda, c/o Melbourne Distribution Centre, Port Melbourne	20.00	"	"
Rushton, Vanessa, c/o K mart, Rosny, Tas.	10.00	"	12.8.83
Stroud, Leo A., c/o Launceston Goods Distribution Centre	30.00	"	22.9.83
Sullivan, Terry, c/o Coles New World Supermarket, Boronia	40.00	"	7.6.83
Tregunning, S., c/o K mart Auto, Nunawading	20.00	"	14.6.83
Bassenberg, Marion, 19 Alma Rd, Hampton Park	30.00	"	4.4.82
Christie, Jean, 1 Epsom Cr, Fawkner	20.00	"	24.8.82
Ford, Rodney, 2 Payne Pl, Launceston,	20.00	"	30.12.81
Gunn, John, 5/7 Featherston St, Armadale	20.00	"	9.5.83
Wake, William, 56 Exter Rd, North Croydon	10.00	"	8.10.81
Higgs, Kevin, 8 Poplar St, Frankston	10.00	"	19.1.82
Hunter, Peter, 18 Wandara Rd, Highton	20.00	"	8.6.82
Kershaw, Ruth, 18 Grenville St, Mooroolbark	20.00	"	"
Knox, Christopher, 75 Hainsworth St, Mulgrave	10.00	"	29.10.82
Lee, Gaye, 24 Greensborough Rd, MacLeod	30.00	"	"
McOwen, Tod, 781 Canterbury Rd, Surrey Hills	30.00	"	22.4.83
Mifsud, Shane, 13 Arcade Way, Avondale Heights	20.00	"	27.1.82
Niblett, Ricky, 58 Peel St, Ballarat	10.00	"	12.2.81
Taylor, Michael, 8 View Point, West Moonah	20.00	"	10.7.83
Lucic, Marie, 42/79 Stoney Rd, Coburg	40.00	"	16.4.83
Turner, Audrey J., Evansford Rd, Clunes & Talbot	10.00	"	9.1.83
Cavanagh, Raymond J., 5/5 Bristol St, West End, Qld	50.00	"	3.9.81
Hustler, Ian L., 15 Parker Rd, Beekenham, W.A.	60.00	"	8.4.82
Clark, Hazel M., 16 James St, Vista, S.A.	10.00	"	24.7.81
Brown, Steven P., 857 Stamford Rd, Kepessa, Qld	10.00	"	8.1.82
Cardell, Tracey L., c/o K mart Mt. Ommaney, Qld	10.00	"	5.10.80
Connolly, Ronald, 187 McDonnell Rd, Margate, Qld	10.00	"	27.3.83
Nielson, Robert, c/o K mart South Tweed Heads, N.S.W.	10.00	"	19.8.82

Unclaimed Moneys Act 1962

Register of Unclaimed Moneys held by the—

<i>Name of Owner on Books and Last Known Address</i>	<i>Total Amount Due to Owner</i>	<i>Description of Unclaimed Money</i>	<i>Date when Amount first became Payable</i>
\$			
G. J. COLES & COY. LIMITED—continued			
Ryan, Gail M., c/o K mart Mt Isa, Qld	20.00	Savings Fund	9.12.83
Sim, Lee, c/o Coles Variety Store, Townsville, Qld	40.00	"	10.12.83
Skelton, Jacquillene, 43 Woodford St, Leichhard, Ipswich, Qld	10.00	"	3.8.81
Blyth, Ruth M., 11 Daylesford Close, South Hedland, W.A.	20.00	"	16.1.81
Ozarczuk, Michael, 3/53 Kirkham Hill Tce, Maylands, W.A.	90.00	"	18.3.83
Bull, Peter, 3/123 Lakemba St, Lakemba, N.S.W.	60.00	"	6.8.81
Mason, Kerrielea, c/o Coles New World Supermarket, Lane Cove, N.S.W.	30.00	"	14.12.80
Taylor, Yvonne V., c/o Coles New World Supermarket, West Pennant Hills, N.S.W.	10.00	"	21.12.81
Carlross, Wayne, 10 Pete St, Marrickville, N.S.W.	40.00	"	29.12.83
Barrett, Kathleen, 37 Lindesay St, Campbelltown, N.S.W.	20.00	"	12.10.83
Bostock, Joan, 120 MacQuarie Ave, Campbelltown, N.S.W.	10.00	"	10.2.84
Campbell, Maureen, 101 Collison St, Tenmbul, N.S.W.	20.00	"	30.6.83
Cardinale, Sebastian, c/o Coles New World Supermarket, Telopea, N.S.W.	10.00	"	18.6.83
Cass, Alan, 36 Shaw Street, Niddrie	10.00	"	15.2.83
Connors, Chris, 2/24 Cartwright Ave, Millen, N.S.W.	20.00	"	20.1.82
Cooper, Mary A., c/o Coles New World Supermarket, Engadine, N.S.W.	140.00	"	7.9.82
Cosatto, Graham, 2/15*19 Terry Rd, West Ryde, N.S.W.	10.00	"	20.6.82
Czaccka, Barbara, 77A Mount St, Lodgee, N.S.W.	10.00	"	11.3.83
Davis, Raymond Barry, c/o Coles New World Supermarket, Bathurst, N.S.W.	10.00	"	26.10.82
Trinder, Joan, 19 Werri Perri Dr, Flagstaff Hill, S.A.	10.00	"	25.9.82
Elliot, Paul A., c/o Coles New World Supermarket, Warriewood, N.S.W.	20.00	"	5.3.84
Finlay, Denise, 7 Giolyile Pl, Giraliong, ACT	10.00	"	22.8.83
Firth, Jacqueline, 29 Josephine St, Georges Hill, N.S.W.	80.00	"	30.3.84
Hannan, Steven, 23 Brian Ave, Lurnea, N.S.W.	20.00	"	14.1.80
Harper, William, 18/19 Saddinton St, St. Marys, N.S.W.	20.00	"	7.11.80
Moon, Raymond, 13 Koobe St, Griffiths, N.S.W.	20.00	"	8.4.82
Nano, Michael, 2/88 Harris St, Fairfield, N.S.W.	10.00	"	25.9.80
Oakes, Barbara, 17 Joan St, Forresters Beach, N.S.W.	10.00	"	22.3.82
O'Brien, Colleen, 261 Hector St, Chester Hill, N.S.W.	20.00	"	1.10.81
Patmore, Lindy, 13 Anthony St, Yagoona, N.S.W.	10.00	"	10.6.83
Rizzo, John, 129 Old Prospect Rd, Wentworthville, N.S.W.	10.00	"	24.2.83
Rudd, Lynn, 119 Bluella St, Villawood, N.S.W.	10.00	"	15.4.81
Urquhast, Robert, c/o Coles New World Supermarket, Castletowers, N.S.W.	60.00	"	16.6.82
Anson, Tina, c/o Coles New World Supermarket, Whyalla, S.A.	10.00	"	10.7.83
Ivans, Ian, c/o Coles New World Supermarket, Inglefarm, S.A.	30.00	"	24.8.83
Lemmon, Victor, c/o Coles New World Supermarket, Whyalla, S.A.	10.00	"	13.8.80
Rocca, Tony, 12 Comwell Dr, Parra Hills, S.A.	70.00	"	6.4.81
Stewart, Allan, 79 Stirling Dr, Whyalla, Stuart, S.A.	10.00	"	12.12.80
Velle, Vince, Lot 6 Melville Rd, St. Clair, N.S.W.	10.00	"	9.7.82
Weir, James, Sper St	10.00	"	13.8.80
Morella, Rhonda, 12 Quean St, Ayr, North Qld	10.00	"	24.12.81
Dixon, Stephen J., 7 Ajax St, Ballarat	80.00	"	10.11.83
Ducker, Janice, 47 Karani Ave, Guildford, N.S.W.	10.00	"	8.4.83
Horan, Cheryl, 79 Peppermint Grv, Engadine, N.S.W.	10.00	"	6.3.81

Unclaimed Moneys Act 1962

Register of Unclaimed Moneys held by the—

<i>Name of Owner on Books and Last Known Address</i>	<i>Total Amount Due to Owner</i>	<i>Description of Unclaimed Money</i>	<i>Date when Amount first became Payable</i>
\$			
McPHERSON'S LIMITED			
Sherwin, B. L., 2 Anita Ave, Mt, Roskill, Auckland 4, N.Z.	12.78	Dividend	3.11.83
Simpson, E. W. E., 115 Lambeth St, Panania, N.S.W.	17.60	"	"
Sollis, K. E., 19/13 Crimea St, St. Kilda	32.00	"	"
Tapper, J., Unit 5/44, Homebush Rd, Strathfield, N.S.W.	40.00	"	"
Tonkin, B. A., 15 Chester Rd, Claremont, W.A.	12.00	"	"
Turner, J. E., 17 Montalto Ave, Toorak	32.16	"	"
Waldie, I. H., c/o G.D.I. Pty. Ltd., 76 Stephen Dve, Woonona, N.S.W.	16.00	"	"
Agnew, M. D., 14 Carron St, North Balwyn	20.08	"	"
Bennett, G. J., c/o George Wilby, 135A Boronia Road, Boronia	123.40	"	"
Bennett, J. W., 9/22 Salisbury St, North Unley, S.A.	60.00	"	"
Byrne, G. J., 2 Peelen Pl, Milperra, N.S.W.	16.00	"	"
Callander, J. D., 12 Martin St, Brighton	16.20	"	"
Collins, K. B., 36 Norman St, Coorparoo, Qld	16.00	"	"
Conte, C., 32 Paterson St, Preston	54.56	"	"
Findlay, T. (estate of), c/o Public Trust Office, c/o Public Trustee, Box 1461N, Melbourne	42.24	"	"
Garrahan, J., P.O. Box 195, West Footscray	18.28	"	"
Garratt, J. H., 100 The Boulevard, Warrandyte	16.00	"	"
Gibson, J. E., 5 Warde St., Bairnsdale	16.88	"	"
Gilbert, D. P., 42 Roseberry St, Balmain, N.S.W.	17.60	"	"
Gill, C. M., Flat 11/8 Illawara Rd, Hawthorn	18.28	"	"
Graham, E. W., 10 Somes Cres, Wellington, N.Z.	15.30	"	"
Grant, W. L., P.O. Box 2, Bulalo, P.N.G.	20.40	"	"
Ham, B. L. W., 3 Balfour St, Toorak	115.84	"	"
Heaton, N. J., 11/78 Old South Head Rd, Bondi Junction, N.S.W.	16.00	"	"
Jackson, L. M., 36 Pashley St, Balmain, N.S.W.	36.80	"	"
Lee, A. F., 14 Austin Ave, Minnamurra, N.S.W.	19.36	"	"
Lowry, K., 62 Rankin Rd, Boronia	65.32	"	"
McCleery, H. J., 2 Diana Dve, North Balwyn	13.68	"	"
McDonald, R. D., 15 Rinford St, Maryborough	10.00	"	"
Milgate, H. B., c/o P.O. Box 214, Northbridge, N.S.W.	40.48	"	"
Morgan, H. C., c/o Michell Sillar & Brown, G.P.O. Box 2524, Sydney, N.S.W.	40.20	"	"
Murphy, P. T., 95 North Rd, Gardenvale	160.00	"	"
Orbuck, F., 2/9 Dickens St, Elwood	46.08	"	"
Ormond, M. W., 2/308 Glenferrie Rd, Malvern	59.68	"	"
O'Sullivan, S., 64 Mont Albert Rd, Balwyn	24.08	"	"
Pretty, C. E., c/o 39 Mariners Reef Rd, Maryborough	11.00	"	"
Reichenbach, W. R., 37 Mayona Rd, Montmorency	17.60	"	"
Robinson, E. H., 219 Mitchell St, Northcote	67.52	"	"
Rovney, E., c/o Redfern Post Office, Redfern, N.S.W.	54.40	"	"
Sabatino, C., 1 Walden Pl, Lalor	16.00	"	"
Sauer, D. F., Unit 1, 51 Holdsworth St, Neutral Bay, N.S.W.	13.20	"	"
Palermo, V., 45 Beatty Ave, Glenroy	24.00	"	22.4.83
Kinhope Pty. Ltd., 4A Thornton Pl, Darling Point, N.S.W.	18.84	"	"
Marshall, A. J., 30 Napier St, Maryborough	14.40	"	"
McCleery, H. J., 2 Diana Dve, North Blackburn	10.26	"	"
Milgate, J. J. (estate of), P.O. Box 214, Northbridge, N.S.W.	30.36	"	"
Garrahan, J., P.O. Box 195, Melbourne	13.71	"	"
Gilbert, D. P., 42 Roseberry St, Balmain, N.S.W.	13.20	"	"
Gill, C. M., 8 Illawara Rd, Hawthorn	13.71	"	"

Unclaimed Moneys Act 1962

Register of Unclaimed Moneys held by the—

<i>Name of Owner on Books and Last Known Address</i>	<i>Total Amount Due to Owner</i>	<i>Description of Unclaimed Money</i>	<i>Date when Amount first became Payable</i>
--	--	---	--

\$

McPHERSON'S LIMITED—*continued*!

Graham, E. W., 10 Somes Cres, Wellington 4, N.Z.	11.47	Dividend	22.4.83
Grant, W. L., P.O. Box 2, Bulalo, P.N.G.	15.30	"	"
Halstead, T. T., 4A Thornton Pl, 21 Thornton St, Darling Point	20.19	"	"
Ham, B. L. W., 3 Balfour St, Toorak	86.88	"	"
Colman, G. G., 10 A Cadell St, Goolwa, S.A.	78.54	"	"
Coson, D. R., 6 Thistle St, Essendon	15.06	"	"
Donnelley, N. M., 47 Bellevue St, Bellevue Hill, N.S.W.	20.28	"	"
Waldie, I. H., c/o G.D.I. Pty. Ltd., 76 Stephen Dve, Woonona, N.S.W.	12.00	"	"
Webster, G. H., 14 Maxwell-Brown Dve, Southport, Qld	205.92	"	"
Weigall, J. D. R., 38 Parslow St, Malvern	15.06	"	"
Yates, E., Firwood Cottage, Spaniards End, Hampstead, NW3, U.K.	127.50	"	"
Reichenbach, W. R., 37 Mayona Rd, Montmorency	13.20	"	"
Rovney, E., c/o Redfern Post Office, Redfern, N.S.W.	40.80	"	"
Simpson, E. W. E., 115 Lambeth St, Panania, N.S.W.	13.20	"	"
Solis, K. E., 19/13 Crimea St, St. Kilda	24.00	"	"
Sutter, C. L., 38 Findlay Ave, Roseville, N.S.W.	60.00	"	"
Murphy, P. T., 95 North Rd, Gardenvale	120.00	"	"
Nelson, D. R. (estate of), c/o Grice and Grice, 283 Whitehorse Rd, Balwyn	36.00	"	"
Nicholson, E. M., c/o The Equity Trustee, 472 Bourke St, Melbourne	56.76	"	"
Orbuck, F., Flat 2, 9 Dickens St, Elwood	34.56	"	"
O'Sullivan, S., 64 Mont Albert Rd, Balwyn	18.60	"	"
Ottway, T. V. and Ellis, M. I., c/o McCay and Thwaites, Suite 4, 321 Camberwell Rd, Camberwell	36.00	"	"
Ellis, M. I. and Ottway, T. V., c/o McCay and Thwaites, 321 Camberwell Rd, Camberwell	60.00	"	"
Embelton, M. P. and G. R. and Montgomery, E. M., c/o 13 Chesterfield Ave, Malvern	51.84	"	"
Atkin, E. M., 730 Pacific Hwy, Gordon, N.S.W.	24.00	"	"
Borella, C. I., Caragulac, Gulpa via Denniliquin, N.S.W.	15.06	"	"
Clarence Alexander Pty. Ltd., 13 Claremont Rd, Enfield, N.S.W.	158.40	"	"
Collins, K. B., 36 Norman St, Coorparoo, Qld	12.00	"	"
7594			

AUSTRALIAN UNITED INVESTMENT COMPANY LIMITED

Shankly, Eliza A. D., Norman S. and Roy B., c/o N. J. Shankly & Shankly, 406 Lonsdale St., Melbourne	150.50	Dividend	16.9.81
Shankly, Norman J., (estate of), c/o N. J. Shankly & Shankly, 406 Lonsdale St., Melbourne	78.75	"	"
Shankly, Eliza A. D., Norman S. and Roy B., c/o N. J. Shankly & Shankly, 406 Lonsdale St., Melbourne	166.80	"	18.3.82
Shankly, Norman J., c/o N. J. Shankly & Shankly, 406 Lonsdale St., Melbourne	87.30	"	"
Shankly, Eliza A. D., Norman S. and Roy B., c/o N. J. Shankly & Shankly, 406 Lonsdale St., Melbourne	24.75	Distribution	6.11.81
Shankly, Norman J., c/o N. J. Shankly & Shankly, 406 Lonsdale St., Melbourne	12.38	"	"
Liddell, Prof. Edward G. T., The Hermitage, Old Headington, Oxford, U.K.	10.89	"	"
7677			

Unclaimed Moneys Act 1962

Register of Unclaimed Moneys held by the—

<i>Name of Owner on Books and Last Known Address</i>	<i>Total Amount Due to Owner</i>	<i>Description of Unclaimed Money</i>	<i>Date when Amount first became Payable</i>
\$			
AUSTRALIAN MUTUAL PROVIDENT SOCIETY			
Alpitsis, Theo, 70 Longley St, Ballarat	17.38	Refund	29.7.83
Archer, C. W., 2/13 Railway Pde, Bayswater	20.00	Withdrawn	13.4.83
Asburn, John G., 320 Napier St, Bendigo	15.31	Lapsed Policy	6.6.83
Ashton, J. A., 7A Davey St, Benalla	18.29	Withdrawn	14.12.83
Asling, G. N., 191 Ray St, Traralgon	12.44	"	15.4.83
Barclay, Laureen M., 3 Lae Cr, Morwell	19.60	Lapsed Policy	5.4.84
Barratt, Alan J., 15 Carre St, Elsternwick	20.16	Refund	4.8.83
Beattie, Stewart K., c/- Post Office, Bundaberg Qld	16.00	Lapsed Policy	14.7.83
Bell, Ian R., c/- Post Office, Ulladulla, Vic.	263.83	Refund	1.9.83
Bell, Russell A., 11/44 Strettle St, Thornbury	41.30	Withdrawn	"
Berryman, F. L., 1/17 Boston Dv, Thomastown	27.30	"	2.11.83
Borg, J., 3 Euroa Ave, North Sunshine	22.00	"	24.12.82
Brant, Geraldine D., 17 Willis St, Frankston	203.19	Lapsed Policy	23.6.83
Brown, E. M.	34.90	Withdrawn	9.11.79
Burrell, Norman W., 5 James St, Wodonga	25.37	Refund	18.8.83
Campbell, D., 11 Somerset St, Glen Iris	28.00	Withdrawn	11.7.83
Chambers, M., 6/263 Lennox St, Richmond	80.00	"	13.4.83
Clayton, Malcolm, 42 Eagle Dve, Noble Park North	373.70	Surrender Value	30.6.83
Collett, P. M., 4/69A Camden Rd, Newtown	15.20	Withdrawn	20.5.82
Cooke, David V., c/- Caravan Gardens, Frankston/Dandenong Rd, Carrum Downs	20.21	"	11.3.83
Cowley, Scott, 4 Currujong Rd, East Hawthorn	14.00	"	11.7.83
Cullen, P. R., 13c Silvan Rd, Monbulk	35.39	Refund	16.2.83
Dixon, S. G., 23 Donne St, West Coburg	35.00	Withdrawn	7.2.83
Garden, Donald, 13 Gropley St, Laverton	26.81	Refund	18.4.83
Feehan, M. J., 75 Napoleon St, Eltham	46.20	Withdrawn	18.4.83
Feidmans, J., 2/74 Collins St, Thornbury	20.00	"	30.12.82
Fenton, James E., 5/83 Collins St, Thornbury	20.00	"	24.10.83
Film Secretariat Retirement Superannuation Plan, 53 Cardigan St, Carlton	33.55	Withdrawal	9.2.83
Fleming, F. C.	16.50	Withdrawn	21.2.84
Ford, Peter J., 6 Sherman St, Forest Hills	27.00	Refund	10.2.83
Freeman, K. R., 12/55 Clow St, Dandenong	42.90	Withdrawn	18.7.83
Gaze, D. J., 13/5 Wegnerst St, Morwell	52.60	"	20.12.82
Gledhill, Leslie C., 44 Andrew St, Windsor	12.00	Refund	24.5.83
Gleeson, Anthony J., RMB 149 Factory Rd, Milawa	49.72	Lapsed Policy	26.1.84
Gordon, R. L.	28.00	Withdrawn	16.4.82
Grillo, M. F.	20.00	"	16.9.80
Gueit, Patrick J. M. C., 146A Poath Rd, Hughdale	20.00	"	29.12.82
Ham, J. W. G., 8 Girdwood Rd, Boronia	21.46	"	25.9.81
Hammington, Murray J., 1/7 Park St, St Kilda	17.00	"	23.9.83
Harrington, Andrew P., P.O. Box 449, Lightning Ridge, N.S.W.	11.60	Refund	21.11.83
Harris, D. M., 11 Harcome St, Bell Post Hill	12.00	Withdrawn	12.8.82
Harrison, Norman L., 215 Heaths Rd, Hoppers Crossing	11.36	Refund	9.6.83
Hayes, Debra N., 74 Sanmateo Ave, Mildura	20.10	Withdrawn	6.12.83
Heale, Ross E., G.P.O. Box 1012H, Melbourne	150.00	Lapsed Policy	4.11.83
Healey, Neville T., 46 Myrtle Gve, Altona	66.00	Refund	2.11.83
Hengst, Bernhard, 6 Jenkins Cr, Wantirna	51.00	Withdrawn	21.2.84
Hogg-Rochetich, A., 16 Elyee Cr, Strathmore Heights	23.28	"	14.4.82
Holloway, E. A., 10/3 Rotherwood Rd, Ivanhoe	24.00	Surrendered	15.7.83
Hosking, J. D.	23.00	Withdrawn	5.4.83

Unclaimed Moneys Act 1962

Register of Unclaimed Moneys held by the—

<i>Name of Owner on Books and Last Known Address</i>	<i>Total Amount Due to Owner</i>	<i>Description of Unclaimed Money</i>	<i>Date when Amount first became Payable</i>
§			
AUSTRALIAN MUTUAL PROVIDENT SOCIETY— <i>continued</i>			
Hughs, B. J. and P.D.	156.00	Withdrawn	20.8.82
Hutcheson, L. M.	39.38	"	9.2.83
Jamieson T.	30.00	Withdrawn	7.1.83
Jayasekera, Ranjith L., 6/10 Broadway, Bonbeach, via Chelsea	75.48	Lapsed Policy	11.11.82
Jeacle, M.	42.30	Withdrawn	5.1.83
Jepsen, Faye M., 1 Doonkuna Ave, Camberwell	141.12	Refund	14.4.83
Jones, Peter R., 434 Gaffney St, Pascoe Vale	45.75	Withdrawn	28.11.83
Kareroa, J. S.	68.25	"	8.11.83
Kilkenny, R. G., 16 Deutscher St, Avondale Heights	10.25	"	11.11.83
Koedem, D. T., 27 Peacock St, Burwood	22.75	"	9.5.83
Ladlow, D. C.	34.00	"	30.7.82
Leake, K. A., R.S.D., Larpent	49.20	"	25.6.82
Lebusque, Ronald S., 1 Arnold Rd, Brighton East	12.50	Refund	12.8.83
Lever, Wayne R., 11 May St, Kew	226.80	Lapsed Policy	11.3.83
Lister, S. J.	40.37	Withdrawn	16.4.82
Liu, Yiuwai, 8 Gloucester Crt, Templestowe	13.39	Surrendered	29.7.83
Lloyd, C. G. G., 12/270 Williams Rd, Toorak	18.82	Refund	24.2.84
Lock, Helen A., 142 Don St, Bendigo	14.90	Lapsed Policy	1.9.83
Marriott, L.	64.00	Withdrawn	17.11.82
Martin, A. G.	40.00	"	26.5.83
Martin, Karen S., 21 Glenifer Ave, Scoresby	12.00	Lapsed Policy	24.9.82
Martin, Lawrence V., 183 Westblade Ave, Kerang	64.16	"	3.6.83
Mather, P. L., 17A Motherwell St, South Yarra	24.29	Withdrawn	29.3.83
McCulloch, K. G.	20.74	"	14.4.83
McDonald, J. L.	16.63	"	1.7.83
McDonald R., 141 Jetty Rd, Rosebud	12.00	"	12.4.83
McGrath, Jeffrey J., 46 Horner St, Hamilton	50.06	Refund	5.10.83
McLeod, Ian D., 61 Charles St, Coburg	30.82	"	3.8.83
Middleton, K.	24.90	Withdrawn	12.5.82
Mulqueeny, Peter F., 1 Woodlands St, East Kew	13.16	Refund	24.10.83
Normington, K. L., 10/10 Stradbroke Ave, Heidelberg	20.00	Withdrawn	5.7.82
O'Dea, P. A., Princely Lodge, Frankston Rd, Currum Downs	46.47	"	18.7.83
Pepper, Leanne M., c/o Mayne Nickless Ltd., G.P.O. Box 1671N, Melbourne	43.60	Withdrawal	7.10.83
Puttyfoot, Howard N., 158 Aberdeen St, Newtown	35.50	Refund	24.2.84
Ridgway, Alan J., 3/204 Ballarat Rd, Footscray	41.98	"	28.6.83
Riseley, Peter J., 71 Fletcher St, Hawthorn	12.56	Lapsed Policy	24.10.83
Russell, K. M., 10 Ashton Rd, Shepparton	20.00	Withdrawn	18.10.83
Samuels, T. A., 2/36 Victoria St, Flemington	33.43	"	25.7.83
Slinn,	19.67	"	4.3.83
Smith, B. I., 7/9 Tiuna Gve, Elwood	33.74	"	11.11.83
Spradbrow, Elabella H., 7 Korong Crt, Mornington	22.73	"	28.5.82
Spradbrow, Yvonne M., 7 Korong Crt, Mornington	38.00	"	4.6.82
Stevenson, R.	24.00	"	16.8.82
Symes, Phillip N., 2/235 Riversdale Rd, Hawthorn	21.23	Refund	8.8.83
Taylor, Deborah M., Lot 25 Dandenong-Hastings Rd, Cranbourne South	21.00	Lapsed Policy	13.2.84
Thai, T. V.	48.39	Withdrawn	1.8.83
Tricot, S. R.	91.55	"	21.12.82
Turinos, J. H.	20.00	"	21.11.82
Walker, Craig S., 31/8-10 The Esplanade, St Kilda	24.85	Refund	12.9.83

Unclaimed Moneys Act 1962

Register of Unclaimed Moneys held by the—

<i>Name of Owner on Books and Last Known Address</i>	<i>Total Amount Due to Owner</i>	<i>Description of Unclaimed Money</i>	<i>Date when Amount first became Payable</i>
--	--	---	--

\$

AUSTRALIAN MUTUAL PROVIDENT SOCIETY—continued

Webb, A. G.	24.82	Withdrawn	24.8.82
West, C. T.	12.40	"	30.4.82
White, D. M., 59 Hume St, Bayswater North	149.42	"	22.12.82
Wignal, J. G.	43.12	"	17.8.79
Wilcox, B. L., 23 Gilbert St, Wodonga	17.73	"	25.6.82
Willis, A. J., Warrnambool	35.88	"	16.1.80
Yuritta, Milos M., 96 Bakers Rd, Coburg	80.20	Lapsed Policy	22.6.83

7678

COLAC DAIRYING COMPANY LIMITED

Barry, G. G. and S., Polleys Road, Barongarook West	26.00	Dividend	13.10.83
Barry, J. L., P.O. Box 123, Colac	11.70	"	"
Berry, M. E., Park St, Bridgewater	13.00	"	"
Box, M., Carlisle River	13.00	"	"
Caspar, F. T. and R. F., Caspar Rd, Forrest	52.00	"	"
Clark, D. L., 72 Sinclair St, Colac	18.20	"	"
Clark, D. L. and E. M., 72 Sinclair St, Colac	26.00	"	"
Darcy, S. F. (estate of M. M.), Coragulac	17.16	"	"
Dare, (estate of T. J. M.), c/o Dare Associates, 189A Clarendon St, South Melbourne	19.50	"	"
Darmody, (estate of C), c/o W. Darmody, Ondit	15.34	"	"
Dowie, J. A., Carlisle River	16.64	"	"
Dryden, L. H., Sloan St, Deniliquin	32.50	"	"
Dunn, (estate of McT.), Chepstowe	31.20	"	"
England, T. G. and V. J., Drung W.S.D., Horsham	17.42	"	"
Fahey, (estate of J.), c/o Clarke & Barwood, 65 Gellibrand St, Colac	19.76	"	"
Henderson, E. R., c/o Royal Women's Hospital, Swanston St, Carlton	13.00	"	"
Hicks, A. R. and J. L., P.O. Box 669 Millicent	13.78	"	"
Horne, V. E. C., 52 Wattle Valley Rd, Canterbury	13.00	"	"
Jones, M. W., Busty Rd, Apollo Bay	17.94	"	"
Lucas, (estate of H. L.), c/o Mrs M. Lucas, 31 Valley Rd, Mt Waverley	11.70	"	"
Methven, M., Flat 1, 9 Hemmings St, Dandenong	34.84	"	"
Potter, N., Calvert St, Colac	40.82	"	"
Priestly, (estate of R.), c/o A. E. Priestly, 70 George St, Fitzroy	13.78	"	"
Roache, E., Larpent R.S.D., Colac	17.42	"	"
Rowe, G. G. and J. D., Gooleys Lane, Dumbalk	24.70	"	"
Siggs, M. G., 78 Kyema Ave, Cumberland Park	29.90	"	"
Steel, T., Portarlington R.M.D., M.S.F. 669, Mail Centre, Geelong	34.84	"	"
Tyrell, N. W. and M. E. F., c/o Ampol Bulk Storage Depot, Wakefield St, Woombye, Qld	11.18	"	"
Ward, A. F., 4 Barb St, Marybymong	13.00	"	"
Zappelli, G. V. and S. A. B., 88 Gellibrand St, Colac	13.78	"	"

7687

BP AUSTRALIA LIMITED

Butler, M. M. D. Guy, Level 38, 140 William St, Melbourne	251.65	Interest	3.2.84
Niehoff, C. F. (estate of), 15 Netherplace Dve, Frankston	28.46	Pension	1.6.83
Turner, L. M. S., 5 Ryeburn Ave, Hawthorn East	25.95	Refund	10.5.83

7682

Unclaimed Moneys Act 1962

Register of Unclaimed Moneys held by the—

<i>Name of Owner on Books and Last Known Address</i>	<i>Total Amount Due to Owner</i>	<i>Description of Unclaimed Money</i>	<i>Date when Amount first became Payable</i>
\$			
INDUSTRIAL EQUITY LIMITED			
Blomley, Graham D., Eagle Bar Station, Bungunya Qld.	53.76	Dividend	15.5.81
Butcher, Laurence F. and Campbell, Ronald G., 77 Ladd St, Watsonia	82.80	"	"
Clegg, Jean, 603 Glen Ormiston, 22 Doris St, North Sydney, N.S.W.	26.60	"	"
Clissold, Charles R. S., P.O. Box 73, Coffs Harbour, N.S.W.	43.36	"	"
Mann, John, c/o Royal Sovereign Hotel, Liverpool St, Darlinghurst, N.S.W.	331.38	"	12.11.81
Sears, Elizabeth C., 49 Louisa Rd, Birchgrove, N.S.W.	82.26	"	15.5.81
Wharton, G. D., c/o Gordon Wharton & Co., Menzies Hotel, Sydney, N.S.W.	11.88	"	"
Bott, Laureen M., 8 The Anchorage Pakuranga, Auckland, N.Z.	51.14	"	"
Butler, John A. A., 2 Craddock St, Avondale, Auckland, N.Z.	29.68	"	"
Costello, Patrick J., 104 Graffon Rd, Roseneath, Wellington, N.Z.	99.72	"	"
Eagle, Cyril J., 26 Paradales Rd, Napier, N.Z.	60.52	"	"
Lawson, Victoria M. W., 71 Bolton St, Wellington, N.Z.	43.83	"	"
McNaught, Colin M., P.O. Box 166, Wellington, N.Z.	463.59	"	"
Wilson, Barry A., Marine Dve, Mahina Bay, Eastbourne, Wellington, N.Z.	20.40	"	"
Cable, James I., 35 Hinemoa St, Kalgoorlie, W.A.	80.01	"	"
Dunning, Leslie F., 27 Spencer St, Bunbury, W.A.	60.93	"	"
Duxfield, Sidney R., Box 7, P.O., Merrylands, N.S.W.	123.57	"	"
Gardner, Gertrude E., 173 Dugan St, Kalgoorlie, W.A.	199.44	"	"
Green, Edward H., 15 McMillan St, Victoria Park, W.A.	120.96	"	"
Griffith, A. R., c/o P.O. Box 293, Broken Hill, N.S.W.	129.60	"	"
De Havas, Cicely, 353 Church St, Melbourne	58.32	"	"
Jackson, Charles A., c/o Keogh O'Neill & Co., 179 St. Georges Tce, Perth, W.A.	167.49	"	"
Johnson, Alfred L., 34 Victoria Ave, Claremont, W.A.	58.32	"	"
Nearney, Lorna R., 118 Lesmudie Rd, Lesmurdie, W.A.	36.09	"	"
Parry, John, 107 Forrest St, Kalgoorlie, W.A.	199.44	"	"
Saunders, Mary J., 11 Veda St, Hamilton, N.S.W.	62.64	"	"
Shorter, Harold A., Ashton Stud, Rosewood, Qld.	134.01	"	"
Stanley, Caroline (estate of), 56 Albert St, Mt. Lawley, W.A.	58.32	"	"
Swans Limited, ACQ Bean Estates Pty. Ltd., 151 Macquarie St, Sydney, N.S.W.	61.08	"	"
Swans Limited, ACQ Bean Estates Pty. Ltd., 151 Macquarie St, Sydney, N.S.W.	75.89	"	"
Todd, James S., Cecil R., Nelsons Plains, via Raymond Tce, N.S.W.	189.36	"	"
Whetham, Elizabeth, P.O. Box 573, Chatswood, N.S.W.	58.32	"	"
Williamson, Isabel M., Roanoke Flats, Francis St, Hyde Park, S.A.	58.32	"	"
Geraghty, Kathleen M., Matamata, N.Z.	54.71	"	"
Kwok, William, 32 Webb St, Wellington, N.Z.	152.84	"	"
Murray, Douglas B. and Jeanette G., C/o. Dyer & Dowd, P.O. Box 5547, Auckland, N.Z.	16.05	"	"
McDonald, James G., c/o T. A. McDonald, 143 Otupua Rd, Timaru, N.Z.	52.45	"	"
Potts, Leslie A. (estate of), c/o K. M. Potts, No. 2 Rd, Tampiri, N.Z.	52.45	"	"
Smith, Hilda, 157 Monks Rd, Lincoln, U.K.	52.45	"	"
McMahon, F. W. (estate of), 7 James St, Manly, N.S.W.	14.80	"	12.11.81
Till, Ethel A., River St, Maclean, N.S.W.	362.80	"	"
Beck, Florence M. (estate of), c/o Re 9, Elcoat & Son, P.O. Box 21, 024 Henderson, Auckland, N.Z.	30.26	"	"

Unclaimed Moneys Act 1962

Register of Unclaimed Moneys held by the—

Name of Owner on Books and Last Known Address	Total Amount Due to Owner	Description of Unclaimed Money	Date when Amount first became Payable
---	------------------------------------	--------------------------------------	--

\$

INDUSTRIAL EQUITY LIMITED—continued

Gilbert, John E. and Dianne J., 5 Stoneroyd Gardens, Remuera, Auckland, N.Z.	17.00	Dividend	12.11.81
MacFarlane, Virginia, The Chimneys Nightcaps, Southland, N.Z.	105.10	"	"
Dunn, Peter T., 16 Donald St, Whangarei, N.Z.	14.88	"	"
Lattimore, Herbert S. (estate of), 18 River St, Taree, N.S.W.	93.28	"	"

7673

PLUMROSE (AUSTRALIA) LIMITED

Cadby, Herbert J., Bullaharre Wayside, via Cobden	28.00	Dividend	11.7.83
Cameron, Z. K., Lowerstoft, Berridale, Tas.	16.63	"	"
Clark, Phyllis M., 9 Macleay St, Dover Heights, N.S.W.	10.00	"	"
Connolly, Gerald R., 9 Devon Crt, Mt. Waverley	16.63	"	"
Cowen, Geoffrey N., 80 Dover Rd, Rose Bay, N.S.W.	25.00	"	"
Cruikshank, Leslie C.R.S., 1/27 Bradleys Head Rd, Mosman, N.S.W.	10.00	"	"
Dixon, William G., 5 Pheonix St, Warragul	20.81	"	"
Garlick, Eleanor, 234 Collins St, Melbourne	16.63	"	"
Geddes, Edwin G., 24 Devonshire St, Croydon, N.S.W.	91.63	"	"
Green, Stuart W., P.O. 189, Woden, A.C.T.	16.63	"	"
Grosvenor, Elsie A., 9 Rosebank Cres, Hurstville, N.S.W.	33.31	"	"
Hedditch, Richard N., 42 Coleman St, Wagga Wagga, N.S.W.	355.56	"	"
Jenkin, O. and Shallard, H., 1 Michelle Crt, Rosanna	16.63	"	"
Kahn, Jenny (estate of), c/o Kahn, J. K., 54 Aroona Rd, Caulfield	138.88	"	"
Mason, Joan M., 5 Dixon Dve, Templestowe	83.31	"	"
Mobilia, Wallace W., 9 Helene St, Eltham	10.00	"	"
Moss, Lovis, 16 Muntz St, North Caulfield	20.00	"	"
Newman, Jocelyn N., 7 Cobby St, Campbell, A.C.T.	16.63	"	"
Petch, Thelma, 82 Nicholson Pde, Cronulla, N.S.W.	16.63	"	"
Pickles, Peter L., 23 Heber St, Moree, N.S.W.	16.63	"	"
Refshauge, Andrew J., 131 Lorraine St, Peakhurst, N.S.W.	10.38	"	"
Roberts, Edward, 283 Queen St, Melbourne	20.00	"	"
Rodriguez, Thomas A., Government House, Canberra, A.C.T.	33.31	"	"
Shaw, Elizabeth C., 17 Shamrock St, Blackall, Qld	10.00	"	"
Steele, Alexander J., 66 Bay Rd, Sandringham	16.63	"	"
Thomas, Noel M., 22 Thanet St, Malvern	25.00	"	"
Thomson, Florence S., 3 Naples Rd, Mentone	25.00	"	"

7686

AUSTRALIAN BARLEY BOARD

Bingham, R. J., Box 74, Bacchus Marsh	147.90	Payment	28.6.83
Atwell, H. C., 20 Eddy St., Rainbow	84.18	"	"
Chivell, O. W. J. and G. W., P.B. 88, Warracknabeal	190.85	"	"
Chivell, O. W. J. and L. O., P.B. 88, Wilkur via Warracknabeal	33.40	"	"
Hoare, P. T. (estate of), 271 Church St, West Geelong	41.20	"	"
Longo, A. and C., Beatty Rd, Rockbank	36.50	"	"
Lilligan Pty. Ltd., Box 23, Toolybuc	16.49	"	"

7681

Unclaimed Moneys Act 1962

Register of Unclaimed Moneys held by the—

Name of Owner on Books and Last Known Address	Total Amount Due to Owner	Description of Unclaimed Money	Date when Amount first became Payable
\$			
THE HERALD AND WEEKLY TIMES LIMITED			
Burns, William J., 29 David St, Hampton	11.25	Dividend	7.5.82
Colanco Pty. Ltd., 6 Blenheim St, Heathmont	22.50	"	"
Donohue, Dean C., c/o Herald and Weekly Times Limited, 44-74 Flinders St, Melbourne	16.87	"	"
Elder, David A., Crossvale, Kamarah, N.S.W.	49.50	"	"
Herring, Eva H., 34 Miami St, East Hawthorn	11.25	"	"
Jolley, Susan M., 511 Bourke St, Surry Hills, N.S.W.	11.25	"	"
Morley, Charles E., c/o J. L. Price, 2 Anne Crt, Heathmont	16.87	"	"
O'Gorman, Imelda M., 4 Noel St, East Brighton	18.53	"	"
Smith, John M., 45 Fitzroy St, Bentleigh	17.85	"	"
Taylor, Anthony J., 2/6 Pritchard Ave, Coogee, N.S.W.	11.25	"	"
Thompson, Roy D., c/o B. F. Hickey, 2/30 Grey St, East Melbourne	18.52	"	"
Baker, Leslie T., Green St, Cervantes, W.A.	11.25	"	"
Dreverman, Peter C., 36 The Point Rd, Woolwich, N.S.W.	15.00	"	"
Huke, John R., 4/29 Hastings St, Scarborough, W.A.	11.25	"	"
Nelson, Timothy S., 51 Evans St, Mt. Helena, W.A.	11.25	"	"
Burns, William J., 29 David St, Hampton	16.87	"	18.12.82
Crawford, Alan S., 5/7 Lewisham Rd, Windsor	25.31	"	"
Delves, John E., and Ball, Rowland J., c/o I. D. Connor, Main Rd, Hurstbridge	84.38	"	"
Donovan, Barry J., 765 Brunswick St, North Fitzroy	25.31	"	"
Dowling, Dianne B., 6 Faraday St, Carlton	168.75	"	"
Elder, David A., Crossvale, Kamarah, N.S.W.	74.25	"	"
Head, Kenneth J., 6 Spring Gully Rd, Bendigo	11.25	"	"
Herring, Eva H., 34 Miami St, East Hawthorn	16.87	"	"
Humphreys, Allan G., c/o F. G. M. Humphreys, 19 Jackman Cres, Keilor	50.63	"	"
Jeeves, Brenda, P.O. Box 114, Darwin, N.T.	18.56	"	"
Johnson, Judith A., c/o J. A. Greig, Lot 1 Macclesfield Rd, Avonsleigh	13.84	"	"
Jolley, Susan M., 511 Bourke St, Surry Hills, N.S.W.	16.88	"	"
Leahy, Charles P., 15 The Avenue, Newport, N.S.W.	84.37	"	"
Leslie, William D., c/o I. W. Leslie, 116 Fuller St, Collaroy Plateau, N.S.W.	25.31	"	"
Lines, Edward J., 2/42 Kingsley Rd, Airport West	16.88	"	"
McHenry, Ursula M., c/o I. D. Connor, 2/850 Main Rd, Hurstbridge	92.81	"	"
Morley, Charles E., c/o J. L. Price, 2 Anne Crt, Heathmont	25.31	"	"
Singleton, Owen P., 30/202 The Avenue, Parkville	459.34	"	"
Spargo, Marie A., c/o A. J. Spargo, 18 Norfolk Rd, Surrey Hills	18.56	"	"
Taylor, Anthony J., 2/6 Pritchard Ave, Coogee, N.S.W.	16.87	"	"
Thompson, Roy D., c/o B. F. Hickey, 2/30 Grey St, East Melbourne	27.78	"	"
Walker, Catherine M., 5/39 Churchill Ave, Cammeray, N.S.W.	15.34	"	"
Jenkins, David, c/o Far Eastern Economic Review, P.O. Box 160, Hong Kong	23.62	"	"
Huke, John R., 4/29 Hastings St, Scarborough, W.A.	16.87	"	"
Nelson, Timothy S., 51 Evans St, Mt. Helena, W.A.	16.88	"	"
7689			
SIDDON'S PTY. LTD.			
Mayo, M. W., 8 Sharrel St, West Heidelberg 7730	58.90	Wages	29.9.83

Unclaimed Moneys Act 1962

Register of Unclaimed Moneys held by the—

<i>Name of Owner on Books and Last Known Address</i>	<i>Total Amount Due to Owner</i>	<i>Description of Unclaimed Money</i>	<i>Date when Amount first became Payable</i>
\$			
HUMES LIMITED			
Baird, John H., 28 Woolwich Rd, Hunters Hill, N.S.W.	441.70	Dividend	31.3.83
Paynter, Rosemary, 325 High St, Kew	46.40	"	"
Scott, Adrian R., c/o Box 39218, Winnellie, N.T.	41.10	"	"
Baird, Moira J., 28 Woolwich Rd, Hunters Hill, N.S.W.	123.40	"	"
Coombe, Rodney, 21 Matheson Rd, Applecross, W.A.	10.26	"	27.10.83
Hudson, Martin, 9 Ellesmere Rd, Windsor	10.32	"	"
Ryan, Rosemary, 46/211 Waterloo Rd, Marsfield, N.S.W.	13.44	"	"
Van Der Draai, Bernard and Mechtilda, 23 Bursaria Cres, Frankston North	12.30	"	"
Meehan, Jack P., 18 Cadby St, Middle Brighton	152.60	"	31.3.83
Lamperd, Robin, P.O. Box 151, Ocean Grove	13.68	"	"
Gladstone, Susan, 9 Hibble St, Meadowbank	12.06	"	27.10.83
Mitchell, Alan, 6 Hood St, Mont Albert	61.60	"	31.3.83
Foster, William, c/o Australian Broadcasting Commission, Box 293E, G.P.O., Brisbane, Qld	30.30	"	27.10.83
Levett, Ellen, 63 MacDonald Ave, Padbury, W.A.	16.00	"	31.3.83
Ockens, Helen, 2 Lytton St, Wentworthville, N.S.W.	12.48	"	"
Parr, Dianne, 19 Addison St, South Perth, W.A.	62.48	"	"
Steinke, Maree, 68 Northcote Rd, Armadale	18.52	"	"
Bird, Julia, 14 Norwood Ave, Brighton	459.72	"	27.10.83
Calvert, James, Myanbah, Uralla, N.S.W.	87.66	"	"
Gaudry, Frances, 26 Mannington Rd, Elizabeth Park, S.A.	184.02	"	"
Gill, Meredith, 162 Morphett Rd, Glengowrie, S.A.	87.48	"	"
Lyall, Joanna, 79 Moxham Ave, Hāitaiti, Wellington, N.Z.	25.50	"	"
Moore, Doris, 57 Denbigh Rd, Armadale	26.25	"	"
Sitch, Charles, 67 Canning St, Avondale Heights	125.16	"	"
Smith, Richard W., 7 Rockingham Cl, Kew	49.98	"	"
Southwell, Bertie, c/o Justice A. Southwell, 17 Parslow St, Malvern	140.52	"	"
Turnour, Quentin, 58 Union St, East Brighton	158.40	"	"
Walsh, Jack, c/o L. Sharpe, 34 Faversham St, Canterbury	108.78	"	"
Young, Peter McK., 73 Blackbutt Ave, Pennant Hills, N.S.W.	69.48	"	"
Yule, Catherine, 2/9 Napoleon St, Sans Souci, N.S.W. 7731	12.96	"	"
H. J. HEINZ COMPANY AUSTRALIA LIMITED			
Carter, M., Eden 7679	34.68	Wages	—2.80
MAX McMAHON REAL ESTATE PTY. LTD.			
Edwards, D., 5/152 Helen St., Morwell	11.43	Rent	3.2.85
Zuwiga, Raul, 92 Commercial Rd., Morwell	13.80	Stamp Duty	15.3.85
Peterson, T., 87 Crinigan Rd., Morwell	155.00	Refund	8.9.84
Kang, E. and Tarang, 6/86 Elgin St, Morwell 7675	154.71	"	11.11.85
OLIVER J. NILSEN (AUSTRALIA) LIMITED			
Moller, J., 34 Norma Ave, Eastwood, N.S.W.	22.76	Dividend	14.5.83
Shankly, N. J., (estate of), 406 Lonsdale St, Melbourne	268.16	"	24.11.83
Catling, M. A., 4/179 Beach Rd, Sandringham	26.40	"	14.5.83
Burnet, H. (Lady), c/o Perpetual Trustees, 50 Queen St, Melbourne	228.08	"	24.11.83
King, K. A. J., 5 Huntingfield Rd, Toorak 7680	22.76	"	"

Unclaimed Moneys Act 1962

Register of Unclaimed Moneys held by the—

<i>Name of Owner on Books and Last Known Address</i>	<i>Total Amount Due to Owner</i>	<i>Description of Unclaimed Money</i>	<i>Date when Amount first became Payable</i>
\$			
P M L PROPERTY TRUST			
Secker, Phillip J., P.O. Box 345, Mandurah, W.A. 7684	135.00	Distribution	31.8.82
BRASH HOLDINGS LIMITED			
Green, Ruth E. K., 8 The Avenue, Windsor	189.07	Dividend	—11.81
Jones, Mary E., 30 Union St, North Williamstown	29.75	"	—11.83
Duffy, R. J., 23 Sutherland Rd, Armadale	69.30	"	—4.84
Shields, Sara J., 10 Lawson St, East Hawthorn 7674	43.28	"	"
NICHOLAS KIWI LIMITED			
Aggiss, James F. J., Deaves Farm, Layham, Ipswich, Suffolk, U.K.	18.41	Cheque	15.4.83
Arnold, Ellen, 37 Newton Park, Blackrock Co, Dublin, Eire	65.52	"	"
Barron, Norman S. (estate of), c/o Sarjeant Brown and Co., 150 Friar St, Reading, RG1 1HF, U.K.	64.11	"	"
Brown, Jessie G. and Harrison-Hall, Jessie M., Ivy House, Church St, Barford, Warwick, U.K.	36.31	"	"
Cardell, Robert F., 8 Peppin St, Camberwell	12.00	"	"
McCaw, Mary A. B., Newton A., and Kenneth M., 124 Monkseaton Dve, Monkseaton, Northumberland, U.K.	36.31	"	"
Cessford, Jenny W., c/o D. J. Sharp Arthur Young and Company, Rua Marques De Subserra 10	31.92	"	"
Cobb, John S., Pond Cottage, Castle Grove Rd, Chobham Woking, Surrey, GU24 8EE, U.K.	60.54	"	"
Coffey, Mervyn N., c/o Ulster Bank Ltd, Athboy Co, Meath, Eire	29.90	"	"
Cooper, Gillian, 17 Cooper's La, Connah's Quay, Deeside Clwyd, CH5 2PX	11.32	"	"
Darugar, Mohamad H. (estate of), Kaf S. A. Teheran, Iran	131.25	"	"
Davis, Oscar, 13 Cheyne Walk, Hendon, London NW4, U.K.	48.45	"	"
Dingwall, Thomas, 11 Branziert Rd North, Killearn, Glasgow	24.22	"	"
Eld, Joseph, 74 Tithe Barn Dve, Bray, Berkshire, SL6 2DG	11.22	"	"
Feather, Francis G., 7 Drake Rd, Westcliff on Sea, Essex, England	95.62	"	"
Foletta, Henry G., 34 St. Georges Rd, Toorak	30.00	"	"
Gilbert, Peter D., Ringdale Manor Cottage, Hernham, Farringdon Oxon, U.K.	45.39	"	"
Grantham, Norman C., 201 Gladstone Ave, Wood Green, London, U.K.	31.87	"	"
Hamilton, Andrew, 91 Ormonde Dve, Glasgow S4, Scotland	19.38	"	"
Hart, David McK., 7 Tweedsmuir Cres, Bearsden, Glasgow, Scotland	24.22	"	"
Hopper, Barry, 12 Boundary Gardens, High Heaton, Newcastle Upon Tyne, U.K.	25.19	"	"
Howard, Allan R., Flat 3, 92 Coogee Bay Rd, Coogee, N.S.W.	12.00	"	"
Jones, Margaret, 2 Bryn Ucha, Rhosrobin Rd, Wrexham, Clwyd LL11 4PL	33.15	"	"
Kelley, Dr Geoffrey R., 49 McComb Blvd, Frankston	12.00	"	"
Knott, Roy McL., c/o Business Development, P.O. Box 8, Kupiano CP, Papua, P.N.G.	14.28	"	"
Lee, Anthony, G.P.O. Box 37, Kensington, N.S.W.	18.00	"	"
Levingstone, Louis, 11 Chapman St, Glasgow, Scotland	24.22	"	"

Unclaimed Moneys Act 1962

Register of Unclaimed Moneys held by the—

<i>Name of Owner on Books and Last Known Address</i>	<i>Total Amount Due to Owner</i>	<i>Description of Unclaimed Money</i>	<i>Date when Amount first became Payable</i>
\$			
NICHOLAS KIWI LIMITED—continued			
Lewis, Theresa, 15 Sommerville Crt, Park Lane, Salford 7, Lancs., U.K.	24.22	Cheque	15.4.83
Lloyd, Gregory G., 26 Baldi Ave, Panania, N.S.W.	18.00	"	"
Morrish, Doris A. J., 3 Windsor House, 33A Lorne Ave, Killara, N.S.W.	24.00	"	"
Moser, Frances E., 8 Victor Hugo St, Paleon Psychio, Athens, Greece	11.97	"	"
Murray, Elizabeth A., 196 Balaclava Rd, North Ryde, N.S.W.	14.88	"	"
Navaraj, Bovorn & Sawankatad, Chaveewan c/o Jauhari (P) Ltd., 99-101 Charden Krung Rd, Bangkok, Thailand	131.25	"	"
Newman, Alan C., 19 Wingate Rd, Woodley, Berks, U.K.	12.14	"	"
Northern Nominees Pty. Ltd., c/o Ian A. North Esq., P.O. Box R257, Royal Exchange, Sydney, N.S.W.	75.00	"	"
Novak, Kinga M. G., Box H110, P.O., Australia Square, Sydney N.S.W.	18.60	"	"
O'Mahony, Kate & O'Mahony James D., c/o T. A. Buckley and Son, 52 Grand Pde, Cork, Eire	81.77	"	"
Patrick, Agnes W. H., 10 Gordon St, Ayr, Scotland	46.00	"	"
Rennie, Margaret, Box 3113 Wellington, N. Z.	15.66	"	"
Richardson, Wendy A., 216B Windsor Lane, Burnham, Bucks, SL1 7HN, U.K.	13.62	"	"
Sangha, Balwinder, Flat 2 Mills House, 62 Mill St, Slough, Berks., U.K.	12.60	"	"
Scholtz, John I., c/o Nicholas Products Pty. Ltd., P.O. Box 19, 16 Trotter Rd, Pinetown, Natal, South Africa	13.86	"	"
Seel, James F., 20 Iredine St, Manchester, U.K.	15.81	"	"
Skippen, Donald, 40 Nunhead La, Peckham, London SE15 3TU, U.K.	18.41	"	"
Slotkin, Hugo, P.O. Box 190, 6353 Tucker Road, Holly Michigan, U.S.A. 48442	15.30	"	"
Smith, Sidney, 2 Bradbrook House, Studio Pl, Kinnerton St, London W1, U.K.	24.22	"	"
Soh, Boon S., 75 Jalan Overseas Union, Overseas Union Gardens, Off Old Kluang Rd, Kuala Lumpur	17.34	"	"
Stevens, Michael J., 2 Illingworth Ave, Caversham Park Village, Reading, Berkshire RG4, ORB	111.79	"	"
Treadgold, Geoffrey C., 21 Clarendon St, Nottingham, NG1 5JA, U.K.	39.78	"	"
Watson, Gill B. (Estate of), c/o Arnott Dodds & Wardlaw, 12 Mosley St, Newcastle Upon Tyne, NE1 1DH, U.K.	48.45	"	"
Weavell, Ivy P., 1/3 Bills St, Hawthorn	37.50	"	"
Wicks, Alfred E., 39 Merriefield Ave, Broadstone Poole, Dorset, BH18 8DA, U.K.	55.69	"	"
Wright, Lynette J., Flat 12, 12 Grange Rd, Glenhuntly	24.00	"	"
Wright, Mary C., Dalveen Edinburgh Rd, Linlithgow, West Lothian, Scotland	58.14	"	"
Zelevska, Joanna, 19 Cardigan St, East St. Kilda 7736	10.86	"	"
NICHOLAS KIWI LIMITED			
Addison, Elizabeth M. C. T., 2A Merchiston Cres, Edinburgh, 10 U.K.	12.44	Cheque	4.11.83
Arnold, Ellen, 37 Newton Park, Blackrock Co., Dublin Eire	76.44	"	"
Barker, John, 19 Nether Beacon, Lichfield, Staffs, U.K.	11.30	"	"
Barron, Norman S. (estate of), c/o Sarjeant Brown and Co., 150 Friar St, Reading RG1 1HF, U.K.	74.79	"	"

Unclaimed Moneys Act 1962

Register of Unclaimed Moneys held by the—

<i>Name of Owner on Books and Last Known Address</i>	<i>Total Amount Due to Owner</i>	<i>Description of Unclaimed Money</i>	<i>Date when Amount first became Payable</i>
§			
NICHOLAS KIWI LIMITED— <i>continued</i>			
Bell, Richard G. and Janet (estate of), 14 Chadstone Rd, Chadstone	14.00	Cheque	4.11.83
Birch, May, 13 Leighville Dve, Herne Bay, Kent, U.K.	21.12	"	"
Bisset, Mary S. C., 470 Pinner Rd, Pinner Middx, U.K.	56.52	"	"
Brown, James C., 43 Stanhope Rd, Croydon CRO 5NS Surrey, U.K.	14.10	"	"
Bunnett, Thelma M., c/o K. Moloney, P.O. Box 41, Balwyn	87.50	"	"
Cardell, Robert F., 8 Peppin St, Camberwell	14.00	"	"
Charles Fox Jewellers Limited, 21 The Arcade, Bournemouth, U.K.	28.26	"	"
Coffey, Mervyn N., c/o Ulster Bank Ltd., Athboy Co., Meath, Eire	34.89	"	"
Cooke, Margaret R. J. C. and Colville, Philip R., 106 Victoria Dve, Bognor Regis, West Sussex, U.K.	40.10	"	"
Cooper, Gillian, 17 Cooper's La, Connah's Quay, Deeside Clwyd CH5 2PX	13.21	"	"
Coveney, Arthur B., Esq., Pentlands Oakwood Rd, Maidstone, Kent, U.K.	11.30	"	"
Cox, Frederick W. (Rev.), 10 Salthouse Rd, Millom, Cumbria LA18 5AD England	11.30	"	"
Crawford, Winifred M., 19 Pinewood Gdns, Aldwick, Bognor Regis, West Sussex	11.30	"	"
Crellin, Olive I., 97 Woolton Rd, Liverpool 15, U.K.	28.26	"	"
Darugar, Mohamad H. (estate of), Kaf S. A. Teheran, Iran	153.12	"	"
Davis, Oscar, Esq., 13 Cheyne Walk, Hendon, London N W 4 U.K.	56.52	"	"
Dawkins, Barbara W., Old Upper Farm, Wood Eaton, Oxford, U.K.	14.10	"	"
Dilworth, Betty, 159 Birtles Rd, Whirley, Macclesfield, Cheshire, SK10 3JH U.K.	28.26	"	"
Dingwall, Thomas, 11 Branziert Rd North, Killearn, Glasgow	28.26	"	"
Eld, Joseph, 74 Tithe Barn Dve, Bray Berkshire, SL6 2DG	13.09	"	"
Ennever, Russell, 3 Mersey Ave, Upminster Essex, U.K.	11.30	"	"
Evans, David M., (Rev.), Moulsoe Rectory, Newport Pagnall, Bucks, U.K.	28.26	"	"
Fibres Australia Pty. Ltd., 3 Bourke St, Bondi Junction, N.S.W.	140.00	"	"
Gilbert, Peter D., Ringdale Manor Cottage, Hernham, Farringdon, Oxon, U.K.	52.95	"	"
Gooding, Edwin A. S., 57 Brassey Rd, London, NW6 2BD	12.44	"	"
Grantham, Norman C., 201 Gladstone Ave, Wood Green, London, U.K.	37.19	"	"
Grey, Leonard G., Greenfield Llantwit Major, Glamorgan, Wales	11.30	"	"
Hamilton, Andrew, 91 Ormonde Dve, Glasgow S4, Scotland	22.61	"	"
Harris, Bessie, Nightingale House (Room 206), Nightingale La, London SW12 U.K.	22.61	"	"
Harris, Dr Stanley J., 404 Mansfield Rd, Nottingham, U.K.	11.30	"	"
Holmes, Michael R., 4 Manorbrook, Blackheath, London, SE3 9AW, U.K.	22.61	"	"
Hopper, Barry, 12 Boundary Gardens, High Heaton, Newcastle Upon Tyne, U.K.	29.39	"	"
Howard, Allan R., Flat 3, 92 Coogee Bay Rd, Coogee, N.S.W.	14.00	"	"
Jennings, Lynn M., The Cottage, West Farndon, Daventry, NN11 6TY, U.K.	56.52	"	"
Jones, Gareth S., Chantry Hurst, 25 Mill Hill, Nettleham, Lincoln LN2 2RJ, U.K.	14.10	"	"
Joyce, Jonathan E., 4/9 Brian Rd, Salisbury, S.A.	350.00	"	"
Kelley, Dr Geoffrey R., 49 McComb Blvd, Frankston	14.00	"	"

Unclaimed Moneys Act 1962

Register of Unclaimed Moneys held by the—

<i>Name of Owner on Books and Last Known Address</i>	<i>Total Amount Due to Owner</i>	<i>Description of Unclaimed Money</i>	<i>Date when Amount first became Payable</i>
\$			
NICHOLAS KIWI LIMITED— <i>continued</i>			
Knott, Roy Mcl, c/o Business Development, P.O. Box 8, Kupiano CP, Papua, P.N.G.	16.66	Cheque	4.11.83
Kreer, Neena, 99 Elliman Ave, Slough, Berks, U.K.	14.70	"	"
Lee, Anthony, G.P.O. Box 37, Kensington, N.S.W.	21.00	"	"
Leirosa Pty. Ltd., c/o D. A. Pellicano, Accountant, 57 Portman St, Oakleigh	14.00	"	"
Leskow, Albert J., 31 Duke St, Balmain, N.S.W.	10.85	"	"
Levingstone, Louis, 11 Chapman St, Glasgow, Scotland	28.26	"	"
Lewis, Theresa, 15 Sommerville Crt, Park Lane, Salford 7, Lancs, U.K.	28.26	"	"
Lipshut, Mary, 211 Kooyong Rd, Toorak	19.60	"	"
Lund, Nora E. (estate of), c/o The Overseas Probate Service Limited, Park House, Bexley, Kent DA5 1HT, U.K.	42.24	"	"
Mackay, Hugh A. and Gertrude E. (estate of), 8 Victoria Sq, Newcastle Upon Tyne 2, U.K.	26.54	"	"
MacKenzie, Ronald J. and Ingham, John R., 8 Dale St, Liverpool, L2 4TQ, U.K.	11.30	"	"
McDowell, Jane F. (estate of), c/o A. D. McCay & Co., 1 Limavady Rd, Waterside, Londonderry BT47 1JU, U.K.	45.22	"	"
McGregor, James A. F., 8 Dundas St, Edinburgh, Scotland	11.30	"	"
McKay, Sir Alex B., Unit 1, Stella Grande, Carinya St, Mooloolaba, Qld	87.50	"	"
Moser, Frances Ethnie, 8 Victor Hugo St, Paleon Psychio, Athens, Greece	13.96	"	"
Murray, Elizabeth A., 196 Balaclava Rd, North Ryde, N.S.W.	17.36	"	"
Navaraj, Bovorn and Sawankatad, Chaveewan, c/o Jauhari (P) Ltd., 99-101 Charoen Krung Rd, Bangkok, Thailand	153.12	"	"
Newland, Matthew, Box 101, Kapunda, S.A.	70.00	"	"
Newman, Alan C., 19 Wingate Rd, Woodley Berks, U.K.	14.16	"	"
Nixon, Margaret J. M., 10 Downview Park, Upper Greenisland Carrickfergus Co., Antrim N. Ireland	11.30	"	"
Novak, Kinga M. G., P.O. Box H110, Australia Sq, Sydney, N.S.W.	21.70	"	"
Omahony, Kate and James D., c/o T. A. Buckley and Son, 52 Grand Pde, Cork, Eire	95.40	"	"
Orourke, Wendy, 33 Taney Cres, Dundsum, Dublin 4	10.88	"	"
Orth, Manfred, 518 Hume Hwy, Yagoona, N.S.W.	35.00	"	"
Palmer, Frederick C., Esq., Farnworth, 34 Moorside Rd, West Cross Swansea	169.57	"	"
Patrick, Agnes W. H., 10 Gordon St, Ayr, Scotland	53.67	"	"
Perrers, Elizabeth Lucy, 4 Mona Rd, Woodford, N.S.W.	42.00	"	"
Prowse, Michael J. (estate of), c/o r. H. Lloyd & Co., Forrester House, St. Peters St, St. Albans, Herts AL1 3LW, U.K.	33.91	"	"
Rees, Margaret E., Ashurst House, Bitchet Green, Sevenoaks, Kent, TN15 OND, U.K.	10.53	"	"
Reis, Spencer M., The Cottage in the Woods, Iver Heath, Bucks, U.K.	357.00	"	"
Rennie, Margaret, Box 3113, Wellington, N.Z.	18.27	"	"
Richardson, Wendy A., 216a Windsor Lnc, Burnham, Bucks, SL1 7HN, U.K.	15.89	"	"
Riding, Alice, 2 The Willows, Milton Rd, Coppull, NR Chorley Lancs, U.K.	11.30	"	"
Rush, Ivy W., 12 George Rd, Solihull, Warwicks, U.K.	21.12	"	"

Unclaimed Moneys Act 1962

Register of Unclaimed Moneys held by the—

<i>Name of Owner on Books and Last Known Address</i>	<i>Total Amount Due to Owner</i>	<i>Description of Unclaimed Money</i>	<i>Date when Amount first became Payable</i>
--	--	---	--

\$

NICHOLAS KIWI LIMITED—continued

Salmon, John D., 2 Chilston Rd, Tunbridge Wells, Kent TN4 9LR, U.K.	223.12	Cheque	4.11.83
Sangha, Balwinder, Flat 2, Mills House, 62 Mill St, Slough Berks, U.K.	14.70	"	"
Scholtz, John I., c/o Nicholas Products, Pty. Ltd., P.O. Box 19, 16 Trotter Rd, Pinetown Natal, South Africa	16.17	"	"
Sedgewick, Robert C., 23 Farm Gve, Rugby, Warwickshire, U.K.	11.30	"	"
Selby, Gerard P. and Julian P., 74 Blomfield Rd, London SW4, U.K.	36.65	"	"
Shaw, Terrance, 3 Carnavon Rd, West Melton	10.85	"	"
Sheringham, James V., c/o Old Farm House, Ingworth, Norfolk, England	66.88	"	"
Siwela, James J. (estate of), 4998 Block 11E, Lamontville 4027, South Africa	12.25	"	"
Skippen, Donald, 40 Nunhead Lne, Peckham, London, SE15 3TU, U.K.	21.48	"	"
Smith, Sidney, 2 Bradbrook House, Studio Pl, Kinnerton St, London, W 1, U.K.	28.26	"	"
Soh, Boon Su, 75 Jalan Overseas Union, Overseas Union Gardens, Off Old Kluang, Rd, Kuala Lumpur	20.23	"	"
Sommers, Norman H. St. John, c/o Hampton Hall Farm, Moor Lne, Rickmansworth, Herts, U.K.	22.61	"	"
Stewart, Lisa A., 85 Rose St, Armadale	14.00	"	"
Sunderland, Albert E., 7 Ansdell Rd, Turf Hill, Rochdale, Lancs, OL1 64TT, U.K.	16.96	"	"
Teare, Lillian M., 5 Phoenix St, Sandycroft, Deeside, Clwyd, Wales, U.K.	14.46	"	"
Treadgold, Geoffrey C., 21 Clarendon, St, Nottingham NG1 5JA, U.K.	46.41	"	"
Vassie, Alan L., 3 Wynnstay Rd, Armadale	14.00	"	"
Warren, Margaret L., 57 Coudray Rd, Southport, PR9 9PE, U.K.	11.30	"	"
Wicks, Alfred E., 39 Merrie field Ave, Broadstone Poole, Dorset, BH18 8DA, U.K.	64.97	"	"
Wilkes, Averil M., 48 Silver Birch Rd, Erdington, Birmingham, B24 OAS, U.K.	31.18	"	"
Wilson, Cherie, 20 Robins Crt, 85 Kings Ave, Streatham, London, SW16	85.50	"	"
Winstanley, Bernard J. R., Carhampton Post Office, Nr Minhead, Somerset, U.K.	21.12	"	"
Woodward, Colonel James E., 33 Sidney Rd, Twickenham, Middlesex, TW1 1JP, U.K.	28.26	"	"
Worth, Brian L. and Wardell, John P. M., c/o Clark Whitehill, 25 New St, Sq, London, EC4A 3LN, U.K.	39.57	"	"
Wright, Lynette Joy, Flat 12, 12 Grange Rd, Glenhuntly	28.00	"	"
Wright, Mary C., Dalveen Edinburgh Rd, Linlithgow, West Lothian, Scotland	67.83	"	"
Zelevska, Joanna, 19 Cardigan St, East St. Kilda	12.67	"	"

7735

DUNLOP OLYMPIC LIMITED

Adams, Joyce G. (estate of), c/o Richard Chant & Croft, 25 Melbourne Rd, Drumcondra	37.56	Cheque	29.4.83
Adams, Mary L., P.O. Box 411, Bairnsdale	12.00	"	"
Ahern, John A., P.O. Box 4, Ingleburn, N.S.W.	48.96	"	"

Unclaimed Moneys Act 1962

Register of Unclaimed Moneys held by the—

<i>Name of Owner on Books and Last Known Address</i>	<i>Total Amount Due to Owner</i>	<i>Description of Unclaimed Money</i>	<i>Date when Amount first became Payable</i>
\$			
DUNLOP OLYMPIC LIMITED—continued			
Allen, Sidney J., c/o ANZ Banking Group, A/C 3766 25038, P.O. Box 11, Maroochydore, Qld	291.41	Cheque	29.4.83
Annrød, Pty, Ltd., c/o Storey Blackwood & Co., P.O. Box C105, Clarence St, Sydney, N.S.W.	92.96	"	"
Arbuthnot, James D., c/o Fimco, Frances Creek, N.T.	12.00	"	"
Atkin, Edith M., 730 Pacific Hwy, Gordon, N.S.W.	36.72	"	"
Badger, John A., c/o Conway MacCallum & Co., 89 York St, Sydney N.S.W.	14.52	"	"
Baird, John H., 28 Woolwich Rd, Hunters Hill, N.S.W.	173.60	"	"
Bakewell, Ann-Marie, Flat 3, 131 Young St, Neutral Bay, N.S.W.	14.40	"	"
Balmain, Nanette E., c/o Allens Private Hotel, 28 Lower Wycombe Rd, Neutral Bay, N.S.W.	37.92	"	"
Barker, Janet M., 40 Princes St, Ryde, N.S.W.	14.72	"	"
Barker, Suzanne M., 1 Somers St, Bentleigh	20.00	"	"
Bell, Stephen A., Box 9514, Newmarket, Auckland, N.Z.	15.30	"	"
Benjamin Holdings Pty. Ltd., Mallam Chambers, 26 Mitchell St, Darwin, N.T.	158.40	"	"
Bentley, Peter M. J., 4/10 Cecil st, Ashfield, N.S.W.	12.00	"	"
Blair, Anne L. L., P.O. Box 486, Benalla	45.32	"	"
Boehm, Kenneth A., Box 332, Port Moresby, P.N.G.	14.21	"	"
Bowling, Jonathan C. S., Wylies Rd, Cygnet, Tas.	32.40	"	"
Bray, Richard W., 23/25 Bolton St, Beaumaris	18.00	"	"
Britto, Julius and Maria L., 189 Victoria St, Ashfield, N.S.W.	30.00	"	"
Brookes, Irene D. I., 126 Central Rd, Avalon, N.S.W.	34.56	"	"
Westpac Bank, A/C Name Mrs Irena D. I. Brooks, A/C Number 901-311, Avalon Beach Branch, N.S.W.	34.56	"	"
Buchanan, Robert J., 19455 Cooley Ave, Detroit, Michigan 48219, U.S.A.	45.90	"	"
Byrne, Margaret M., 3/24 Parnell St, Elsternwick	76.80	"	"
Calvert, James L., Myanbah, Uralla, N.S.W.	100.00	"	"
Carpenter, Rosalind A., c/o Investment Service Dept., Bank of New South Wales, 360 Collins St, Melbourne	120.00	"	"
Castle Credits Pty. Ltd., 7A Station St, Pymble, N.S.W.	19.76	"	"
Ceylon, Charles, 9/2A Penkivil St, Bondi, N.S.W.	36.00	"	"
Chadban, Robert M. and Carol, 20 Essington Lewis Ave, Whyalla, S.A.	20.00	"	"
Chia, Siak K, 73 Seng Goon Garden, Kuching, Sarawak, Malaysia	12.51	"	"
Clancy, Adelaide F. (estate of), c/o Public Trust Office, P.O. Box 660, Newcastle, N.S.W.	15.00	"	"
Clegg, Albert and Brenda, Flat 5, 30 Lemnos St, Red Hill, Qld	73.36	"	"
Colditz, Paul B., 3/8 Pitt St, Randwick, N.S.W.	12.00	"	"
Cook, Dr James C., 'Beaudesert' Mudgee, N.S.W.	15.72	"	"
Coombes, Rosemary N., 163 Gannons Rd, Caringbah, N.S.W.	13.67	"	"
Coutts, Lesley A., Cooma, Mt. Beckworth via Creswick	110.00	"	"
Cox, Peter, 431 Wellington St, Clifton Hill	36.72	"	"
Crane, Peter C., 48 Edwin St, Croydon, N.S.W.	14.04	"	"
Creer, Dahlis V., 14 Geelway Pl, Deakin, A.C.T.	14.40	"	"
Currie, William N., 43 Apex Ave, Moorabbin	15.84	"	"
Day Holdings Pty. Ltd., 218 Beaudesert Rd, Moorooka, Qld	71.16	"	"
Dharmalingam, Juliet S., c/o 21 Crystal Cres, Wyong, N.S.W.	25.20	"	"
Digney, Leeanne, 17 Mainoru Pl, Hawker, A.C.T.	24.48	"	"

Unclaimed Moneys Act 1962

Register of Unclaimed Moneys held by the—

<i>Name of Owner on Books and Last Known Address</i>	<i>Total Amount Due to Owner</i>	<i>Description of Unclaimed Money</i>	<i>Date when Amount first became Payable</i>
\$			
DUNLOP OLYMPIC LIMITED— <i>continued</i>			
Dixon, Charles E. (estate of), c/o Wisewoulds, 459 Little Collins St, Melbourne	14.40	Cheque	29.4.83
Downes, Ruth J., 16 Heights Cres, Middle Cove, N.S.W.	12.00	"	"
Downing, Phyllis G., 2 Hensman St, South Perth, W.A.	309.32	"	"
Duncan, James W. and MacDermott, C. F., c/o C. F. MacDermott, 15 Fitzherbert Tce, Wellington, N.Z.	12.24	"	"
Dupont, G. E. A. and Y. E. and R. A. and L., De Desinfectants Laboratories, Marocain Rue Medecin, Major Ayrand, Casablanca, Morocco	65.18	"	"
Edwards, Francis A. and Bray, Jonathon, c/o MacKay Taylor & Co., 131 Kepler St, Warrnambool	164.16	"	"
Edwards, Janice, 43 Wilson St, Broken Hill, N.S.W.	13.20	"	"
Elliot, Doris N., 3 Exford Pl, Donvale	12.00	"	"
Evans, Irene M., c/o John I Sullivan, Chisholm & Associates, P.O. Box 35, Caulfield North	23.60	"	"
Foletta, Henry C., Woodside, Bonds Rd, Lower Plenty	12.00	"	"
Gala Holdings Pty, Limited, 96 Flinders St, Melbourne	26.40	"	"
Gelman, Colin, 97 Rose St, Fitzroy	11.00	"	"
Gill Veronica M. C., 12 Drummond St, Blackburn South	32.40	"	"
Glisson Jann, 54 St. Elmo Pde, Kingsgrove, N.S.W.	12.96	"	"
Goldsmith, Gerald, P.O. Box M3, Sydney Mail Exchange, Sydney, N.S.W.	60.00	"	"
Golten, Roger C., Base Flat, 51 St. Stephen's Gdns, London W2 7QX, U.K.	41.55	"	"
Grainger, Henry T., 15 Truganini St, Burnie, Tas.	10.40	"	"
Gramahlo Pty. Ltd. c/o R. H. Morrison, 37 Swanston St, Melbourne	120.00	"	"
Grice, Alma O., 5 Stephenson St, Sadlers Crossing, Ipswich, Qld	120.0	"	"
Gruszin, Joyce V., c/o Peko Mines, Tennant Creek, N.T.	17.04	"	"
Hadfield, Keith S., 46 Helmores Lane, Christchurch 1, N.Z.	20.57	"	"
Hall, Elizabeth C., 60 Lyttleton St, Launceston, Tas.	26.88	"	"
Hansen, David T., 13 The Oval, Seletar Airbase, Singapore	10.20	"	"
Harburn Colin M. and Glenys M., 33 Glendale Cres, Jandakot, W.A.	20.00	"	"
Harburn, Haris M., 33 Glendale Cres, Janelakot, W.A.	20.00	"	"
Hendriks, Dianne L., 8 Hawdon St, Broadford	21.60	"	"
Hogarth, Yolande M., 49 Tamar St, Annerly, Qld	13.20	"	"
Hughes, Judith A., 'Holmesdale Tower', 9a/50 Whaling Rd, Neutral Bay, N.S.W.	32.88	"	"
Hunt, Esme R. K., 19/14-24 Kidman St, Coogee, N.S.W.	33.00	"	"
Hyne, Margaret J., 331 Sennox St, Maryborough, Qld.	75.84	"	"
Johnson, Ernest J., Bar Hill Cottage, Madeley near Crewe, Staff. U.K.	12.24	"	"
Johnson, Philippa C., 7 Arabelle St, Longueville, N.S.W.	15.40	"	"
Jolly, Edward M., P.O. Box 81, Nyah West	12.00	"	"
Kelley, Geoffrey R., 3 Archer Cl, Mt Eliza	12.00	"	"
Kelley, G. R., ANZ Bank, A/c No. 9722288, 67 Mt. Eliza Way, Mt. Eliza	26.60	"	"
Kennedy, John A. C., 25 Seaview Ave, Bentleigh	26.60	"	"
Kosky, Sol (estate of), and Walker, E. and Kosky, F. (estate of), 8/40 Gerard St, Cremorne, N.S.W.	271.80	"	"
L. G. Glenowen Investments Pty, Limited, c/o Gordon, L. G., 38 Balfour Rd, Rose Bay N.S.W.	246.40	"	"
LaMeszaros, Be, 5 Hamesley Ave, Morley, W.A.	60.00	"	"

Unclaimed Moneys Act 1962

Register of Unclaimed Moneys held by the—

<i>Name of Owner on Books and Last Known Address</i>	<i>Total Amount Due to Owner</i>	<i>Description of Unclaimed Money</i>	<i>Date when Amount first became Payable</i>
\$			
DUNLOP OLYMPIC LIMITED— <i>continued</i>			
Lang, Diana, 11 Tintern Ave, Toorak	30.00	Cheque	29.4.83
Lawless, Burnett R., Boonbyjan, Goomers, Qld	55.20	"	"
Laxton, Ernest G., 186-188 Smiths St, Collingwood	40.36	"	"
Lewis, Vera B., 29 Pasadena St, Kogarah, N.S.W.	11.20	"	"
Livesley, Joyce H., 3 Pratten Ave, Ryde, N.S.W.	17.40	"	"
Lyall, Nanette E., 14A Red Chapel Ave, Sandy Bay, Tas.	18.60	"	"
Marshall, Valmai, 183 Evans St, Rozelle, N.S.W.	29.36	"	"
Mason, David P., 150 Leila Rd, Murrumbena	45.52	"	"
McIvor, Sonia J., 85 Crystall St, Petersham, N.S.W.	21.60	"	"
McKean, William J., 78 Murdoch Rd, Wangaratta	11.72	"	"
McLennan, Iain A., c/o Manion McCosker, Temple Crt, 75 Elizabeth St, Sydney, N.S.W.	78.24	"	"
McShane, Beatrice F., 15/150 Bellevue Rd, Bellevue Hill, N.S.W.	53.84	"	"
Metcalfe, John W. (estate of), c/o Remington & Co., GPO Box 5082, Sydney, N.S.W.	73.80	"	"
Middleton, Dr Geoffrey C., 24 Fullers Rd, Chatswood, N.S.W.	80.72	"	"
Mitchell, Betty W., 36 Henderson St, Eastwood, N.S.W.	12.00	"	"
Mitchell, Dulcie, c/o Rev. James O. Mitchell, 21 Handon St, Mansfield, Qld.	24.48	"	"
Moeller, Charles H., P.O. Box 624, Surfers Paradise, Qld	15.00	"	"
Moore, Grace C., Flat 5, 114 Darling Rd, East Malvern	13.52	"	"
Morgan, Hugh and Rogan, John, Unit 4, 83-87 Wellington St, Windsor	48.96	"	"
Morris, Cecil A., 570 Bershire Rd, Forresterfield, W.A.	14.72	"	"
Murphy, Helen M., 14 Washington St, Toorak	93.64	"	"
Naughton, Elizabeth L., 44 Parnell St, Elsternwick	30.56	"	"
Newman, Kevin W., 58 Kendall St, Sans Souci, N.S.W.	14.72	"	"
Nichols, Ian A. (estate of), c/o K. F. Lowrie, P.O. Box 68, Moonah, Tas.	36.72	"	"
O'Brien, Danny J., 10 Lambourne St, Surrey Hills	12.00	"	"
Osborne, Constance I. (estate of), c/o The Trustees Executors & Agency Co. Limited, G.P.O. Box 389D, Melbourne	69.24	"	"
Ottawa, Thomas V., and Ellis, Maureen I., c/o McCay & Thwaites, 321 Camberwell Rd, Camberwell	180.00	"	"
Paul, Geoffrey, 185 Hope St, Bathurst, N.S.W.	14.40	"	"
Paul, Helen M., 11/14 Manningtree Rd, Hawthorn	28.44	"	"
Pentland, Debora J., McInnes, 11 Polaris Dve, Sale	107.60	"	"
Persson, Conrad L., 2 Glenrock Ave, East Wairoonga, N.S.W.	15.00	"	"
Probert, Barry J., 3 Corinda Ave, Kensington Park, S.A.	14.72	"	"
Pura, Lionel M., Unit 1/171 Wattle Valley Rd, Camberwell	18.00	"	"
Ten Raa, William F., c/o Dept of Anthropology, University of Western Australia, Nedlands, W.A.	28.80	"	"
Robert M. Hadley Company Inc, 750 West Fifty-First Street, Los Angeles, California, United States of America 90037	510.00	"	"
Robinson, John C., P.O. Box 1213, Kota Kinabalu, Sabah, East Malaysia	10.88	"	"
Davies-Roe, Paul E., 1 Orchard St, Thornleigh, N.S.W.	14.40	"	"
Roget, Mabel E. (estate of), c/o 16 Glassford St, Armadale	20.52	"	"
Rose, Allan, 5/343 Edgecliff Rd, Edgecliff, N.S.W.	12.00	"	"
Rosenberg, Alan D., 17 Hunter St, Dover Heights, N.S.W.	17.60	"	"
Runnel, Valdu, 337 Montague Rd, Para Vista, S.A.	54.32	"	"
Sands, Roger L., 164 Elswick St, Leichhardt, N.S.W.	18.00	"	"

Unclaimed Moneys Act 1962

Register of Unclaimed Moneys held by the—

Name of Owner on Books and Last Known Address	Total Amount Due to Owner	Description of Unclaimed Money	Date when Amount first became Payable
\$			
DUNLOP OLYMPIC LIMITED—continued			
Scannell, Michael F., 25 Elsmere St, Kensington, N.S.W.	132.32	Cheque	29.4.83
Schmidt, Harry P., 68 Virginia St, Mt Waverley	11.16	"	"
Shaw, Alan D., 4 Arnold St, Warracknabeal	41.24	"	"
Shearer, Peter D., 257 Hawkin Dve, St. Lucia, Qld.	12.00	"	"
Shepherd, Alwyn A., 177 Ruahine St, Palmerston North, N.Z.	12.24	"	"
Shinn, Gwendoline M., 118 Fernleigh Rd, Wagga Wagga, N.S.W.	15.68	"	"
Singleton, Owen P., Flat 30, 202 The Avenue, Parkville	62.76	"	"
Sleat, Ian L., Flat 4, The Grange, 10 Grange Hill, London SE 25 U.K.	13.87	"	"
Smith, Peter G., 5 McMillan Cr, Southport, Qld.	58.72	"	"
Southey, Jane M., 47 Scott St, Beaumaris	28.88	"	"
Spies, Gwendoline M., 28 Ferry Ave, Beverley Park, N.S.W.	20.00	"	"
Street, Dermont C., 34 Muritai Rd, Takapuna, Auckland 9, N.Z.	12.34	"	"
Tan, Dr Tiong Choon, P.O. Box 5855, Boroko, Port Moresby, N.G.	51.00	"	"
Thompson, Marjorie B., 11 Quinton Rd, Manly, N.S.W.	52.08	"	"
Thomson, Andrew C., and Susan E., 39 Bidwell St, Wellington, N.Z.	47.60	"	"
Tuckwell, Ethel M., 18/2 Farrell St., Glenelg South, S.A.	76.12	"	"
Vilcins, Jekabs and Martins, 176 Commercial Rd, Morwell	21.52	"	"
Volk, John N. (estate of), c/o James P. Ogge & Co., P.O. Box 129, Prahran	18.88	"	"
Wale, Philip J., 75 Thames St, Box Hill	12.00	"	"
Walsh, David and Susan, 8 Avonhurst Dve, Glen Waverley	16.00	"	"
Waterfield, Glen, 41 Surrey Cres, Grey Lynn, Auckland, N.Z.	10.20	"	"
Way, Lewis M. (estate of), c/o Northcote & Co., P.O. Box 548, Cophthall Close, London EC2P 2JJ U.K.	35.50	"	"
Weeks, Roger B., 7th Floor Kayamally Building, 22 Queens Road, Central Hong Kong	25.20	"	"
Wells, Aird and Hope, Anthony J., P.O. Box 80, Kojonup, W.A.	13.20	"	"
Wesney, Constance E., 57 Falkirk Ave, Seatoun, Wellington, N.Z.	24.96	"	"
Whittle, Margaret F. (estate of), c/o J. W. Whittle, 50 Tennyson St, Kew	16.00	"	"
Wild, Dr John P., 3 Strathfield Ave, Strathfield, N.S.W.	14.40	"	"
Young, Dr Brian L., 21 Bingley Cres, Fraser, A.C.T.	48.00	"	"

Companies Form 24, Registered No. C79256
EKISTICS PTY. LTD.

Notice of Resolution

At the general meeting of members of the company duly convened and held at the office of E. P. Taylor & Co., 583 Hampton Street, Hampton on 17 April 1985 the special resolution set out below was duly passed:

That the Company commence proceedings under the Companies (Victoria) Code to liquidate the Company under a members voluntary winding up.

That Mr Ronald Leslie Male of E. P. Taylor & Co., Chartered Accountants, 583 Hampton Street, Hampton be appointed liquidator of the Company.

Dated 17 April 1985

7868

LAVERTON (No. 2) CO-OPERATIVE HOUSING
SOCIETY LIMITED (In Liquidation)

Special Resolution

Passed on 24 April 1985

At a special general meeting of the abovenamed society, duly convened and held at 423 Bourke Street, Melbourne on Wednesday 24 April 1985 at 5.30 p.m., the subjoined special resolution was duly passed—

That the society having successfully completed its objectives sixty nine (69) months ahead of its expected term be wound up voluntarily, and that Kevin Edward Palmer of 423 Bourke Street, Melbourne be appointed Liquidator for the purposes of the Winding Up.

7906

B. J. ROSE, Secretary

In the Supreme Court of Victoria—Co. No. 192 of 1985—In the matter of section 320 of the Companies Code 1981; and in the matter of section 364 of the Companies Code 1981; and in the matter of Power Plus Tyre Service Pty. Ltd.

Notice is hereby given that a Petition for the winding up of the above-named company by the Supreme Court was on 26 March 1985, presented by John Power and Meron Ellen Power. And that the said petition is directed to be heard before the Court sitting at Melbourne at 10.30 a.m. on 16 May 1985; and any creditor or contributory of the said company desiring to support or oppose the making of an order on the said petition may appear at the time of hearing by himself or his counsel for that purpose; and a copy of the petition will be furnished to any creditor or contributory of the said company requiring the same by the undersigned on payment of the regulated charge for same.

The Petitioner's address is: Patrick Cash & Associates, 161 Nicholson Street, Footscray 3011.

The Petitioner's Solicitor is: P. Mecoles of Patrick Cash & Associates, of 161 Nicholson Street, Footscray 3011.

PATRICK CASH & ASSOCIATES, solicitors for the petitioners

Note: Any person who intends to appear on the hearing of the said petition must serve on or send by post to the abovenamed solicitor notice in writing of his intention so to do. The Notice must state the name and address of the person, or if a firm, the name and address of the firm, and must be signed by the person or firm, or his or their solicitor (if any), and must be served, or, if posted, must be sent by post in sufficient time to reach the above named not later than 4.00 p.m. on 15 May 1985. 7867

Companies (Victoria) Code

Section 392 (2) (b)

A.E.M. (VIC.) PTY. LTD.

Notice is hereby given that at a general meeting of members of the abovenamed company held on 26 April 1985 it was resolved that the company be wound up voluntarily, as a members' voluntary winding up pursuant to the provisions of sub-division (B) of Division 3 of Part XII of the Companies (Victoria) Code, and it was further resolved that for such purpose, Ronald Charles Bray, Public Accountant of 352-360 St. Kilda Road, St. Kilda, be appointed Liquidator.

Notice is also given that after twenty-one days from this date we shall proceed to distribute the assets. Any creditors having any claims against the Company should furnish particulars of same by that date, otherwise we shall proceed to distribute the assets without regard to their claims.

Dated 26 April 1985

R. C. BRAY, Liquidator

Greenfield Fox Hansen & Co., 352-360 St. Kilda Road, St. Kilda 7908

In the Supreme Court of Victoria—1984 Co. No. 458—In the matter of the Companies (Victoria) Code 1982; and in the matter of Trivest Corporation Limited—Schedule

Notice is hereby given that by Order made 22 November 1984 the Supreme Court of Victoria:

(a) Confirmed the reduction of capital of Trivest Corporation Limited resolved upon by special resolution of the abovenamed company which was duly passed on 27 April 1984 in the following words and figures, that is to say:

(a) "That subject to the passing of resolutions 4 and 5 by the shareholders, the confirmation of the Supreme Court of Victoria and pursuant to Articles 42 and 44 of the Articles and section 123 of the Code the paid up capital of the Company be reduced from \$1 919 281.00 (comprising 1 683 017 fully paid shares of \$1.00 each and 2 372 640 contributing shares of \$1.00 paid to 10 cents each) to \$95 964.20 (comprising 420 505 fully paid shares of 20 cents each and 593 160 contributing shares of 20 cents paid to 2 cents each) by cancelling the sum of \$1 823 316.80 being paid up capital which is lost and is also unrepresented by available assets to the extent of 95 cents per share on each of the fully paid shares (total \$1 597 916.00) and to the extent of 9.5 cents per share on each of the partly paid shares (total \$225 400.80)."

(b) Declared that the share capital of Trivest Corporation Limited as altered by such order is \$50 000 000.00 and that by reason of the term of the special resolution referred to in paragraph (a) above and by reason of the confirmation of the said reduction of capital and by reason of certain further resolutions which further resolutions were conditional upon the making of the said order, the share capital of Trivest Corporation Limited at the date of the making of the order is \$50 000 000.00 consisting of:

i 420 505 issued and fully paid ordinary shares of 20 cents each and 593 160 issued ordinary shares of 20 cents each paid to 2 cents each.

ii 248 986 335 unissued ordinary shares of 20 cents each.

(c) Ordered that an office copy of this order be lodged with the Commissioner for Corporate Affairs within 14 days from the date hereof.

(d) Ordered that within 14 days from the registration of the office copy of this order notice of this order be published once in the "Government Gazette", once in the Age newspaper.

By Order of the Board

JOHN WILLIAM BARR
Secretary

In the Supreme Court of Victoria—Co. 249—In the matter of the Companies (Victoria) Code; and in the matter of Corporate Finance Pty. Limited

Notice is hereby given that an application for the winding up of the abovenamed company by the Supreme Court was on 24 April 1985 presented by James Edward McTigue, Deputy Commissioner of Taxation of the Commonwealth of Australia and that the said application is directed to be heard before the Court sitting at the Fifteenth Court, Law Courts, Lonsdale Street, Melbourne at 10.30 a.m. on 30 May 1985 and any creditor or contributory of the said company desiring to support or oppose the making of an order on the said application may appear at the time of hearing by himself or his counsel for the purpose; a copy of the said application will be furnished to any creditor or contributory of the said company requiring the same by the undersigned on payment of the regulated charge for the same.

The Applicant's official address is: 350 Collins Street, Melbourne.

The Applicant's Solicitor is: Australian Government Solicitor, of 200 Queen Street, Melbourne.

Note: Any person who intends to appear on the hearing of the said application must serve on or send by post to the abovenamed Australian Government Solicitor notice in writing of his intention to do so. The notice must state the name and address of the person, or, if a firm, the name and address of the firm, and must be signed by the person or firm, or his or their solicitor (if any), and must be served, or if posted, must be sent by post in sufficient time to reach the abovenamed Australian Government Solicitor not later than 4.00 p.m. on 29 May 1985. 7881

In the Supreme Court of Victoria—Co. 247—In the matter of the Companies (Victoria) Code; and in the matter of Jisto Harmonia Nominees Pty. Ltd.

Notice is hereby given that an application for the winding up of the abovenamed company by the Supreme Court was on 24 April 1985 presented by James Edward McTigue, Deputy Commissioner of Taxation of the Commonwealth of Australia and that the said application is directed to be heard before the Court sitting at the Fifteenth Court, Law Courts, Lonsdale Street, Melbourne at 10.30 a.m. on 30 May 1985 and any creditor or contributory of the said company desiring to support or oppose the making of an order on the said application may appear at the time of hearing by himself or his counsel for the purpose; a copy of the said application will be furnished to any creditor or contributory of the said company requiring the same by the undersigned on payment of the regulated charge for the same.

The Applicant's official address is: 350 Collins Street, Melbourne.

The Applicant's Solicitor is: Australian Government Solicitor, of 200 Queen Street, Melbourne.

Note: Any person who intends to appear on the hearing of the said application must serve on or send by post to the abovenamed Australian Government Solicitor notice in writing of his intention to do so. The notice must state the name and address of the person,

or, if a firm, the name and address of the firm, and must be signed by the person or firm, or his or their solicitor (if any), and must be served, or if posted, must be sent by post in sufficient time to reach the abovenamed Australian Government Solicitor not later than 4.00 p.m. on 29 May 1985. 7882

In the Supreme Court of Victoria—Co. 248—In the matter of the Companies (Victoria) Code; and in the matter of Acland Finance and Leasing Pty. Ltd.

Notice is hereby given that an application for the winding up of the abovenamed company by the Supreme Court was on 24 April 1985 presented by James Edward McTigue, Deputy Commissioner of Taxation of the Commonwealth of Australia and that the said application is directed to be heard before the Court sitting at the Fifteenth Court, Law Courts, Lonsdale Street, Melbourne at 10.30 a.m. on 30 May 1985 and any creditor or contributory of the said company desiring to support or oppose the making of an order on the said application may appear at the time of hearing by himself or his counsel for the purpose; a copy of the said application will be furnished to any creditor or contributory of the said company requiring the same by the undersigned on payment of the regulated charge for the same.

The Applicant's official address is: 350 Collins Street, Melbourne.

The Applicant's Solicitor is: Australian Government Solicitor, of 200 Queen Street, Melbourne.

Note: Any person who intends to appear on the hearing of the said application must serve on or send by post to the abovenamed Australian Government Solicitor notice in writing of his intention to do so. The notice must state the name and address of the person, or, if a firm, the name and address of the firm, and must be signed by the person or firm, or his or their solicitor (if any), and must be served, or if posted, must be sent by post in sufficient time to reach the abovenamed Australian Government Solicitor not later than 4.00 p.m. on 29 May 1985. 7883

MONASH NO. 2 CO-OP. HOUSING SOCIETY LTD.

Notice of Final Meeting in Voluntary Winding Up

Take notice that the affairs of the above-named Society are now fully wound up and that in pursuance of section 272 (1) of the *Companies Act 1961* and the *Co-Operative Housing Societies Act 1958*, a General Meeting of the Society will be held at 7 Russet Rd., Ringwood East on 30 May 1985 for the purposes of—

- (i) laying before it an account showing how the winding up has been conducted and the property of the Society disposed of and giving any explanations thereof; and
- (ii) passing a resolution that the books and papers of the said Society and of the Liquidator relevant to the affairs of the Society be destroyed after a period of twelve months from the date of the meeting.

Dated 23 April 1985

B. R. A. KING
Liquidator

In the Supreme Court of Victoria—Co. 242—In the matter of the Companies (Victoria) Code; and in the matter of Aust.—Ind. Services Pty. Ltd.

Notice is hereby given that an application for the winding up of the abovenamed company by the Supreme Court was on 24 April 1985 presented by James Edward McTigue, Deputy Commissioner of Taxation of the Commonwealth of Australia and that the said application is directed to be heard before the Court sitting at the Fifteenth Court, Law Courts, Lonsdale Street, Melbourne at 10.30 a.m. on 30 May 1985 and any creditor or contributory of the said company desiring to support or oppose the making of an order on the said application may appear at the time of hearing by himself or his Counsel for the purpose; a copy of the said application will be furnished to any creditor or contributory of the said company requiring the same by the undersigned on payment of the regulated charge for the same.

The applicant's official address is: 350 Collins Street, Melbourne.

The applicant's solicitor is: Australian Government Solicitor, of 200 Queen Street, Melbourne.

Note: Any person who intends to appear on the hearing of the said application must serve on or send by post to the abovenamed Australian Government Solicitor notice in writing of his intention to do so. The notice must state the name and address of the person, or, if a firm, the name and address of the firm, and must be signed by the person or firm, or his or their solicitor (if any), and must be served, or if posted, must be sent by post in sufficient time to reach the abovenamed Australian Government Solicitor not later than 4.00 p.m. on 29 May 1985. 7887

In the Supreme Court of Victoria—Co. 243—In the matter of the Companies (Victoria) Code; and in the matter of Ergo Design Furniture Manufacturers Pty. Ltd.

Notice is hereby given that an application for the winding up of the abovenamed company by the Supreme Court was on 24 April 1985 presented by James Edward McTigue, Deputy Commissioner of Taxation of the Commonwealth of Australia and that the said application is directed to be heard before the Court sitting at the Fifteenth Court, Law Courts, Lonsdale Street, Melbourne at 10.30 a.m. on 30 May 1985 and any creditor or contributory of the said company desiring to support or oppose the making of an order on the said application may appear at the time of hearing by himself or his Counsel for the purpose; a copy of the said application will be furnished to any creditor or contributory of the said company requiring the same by the undersigned on payment of the regulated charge for the same.

The applicant's official address is: 350 Collins Street, Melbourne.

The applicant's solicitor is: Australian Government Solicitor, of 200 Queen Street, Melbourne.

Note: Any person who intends to appear on the hearing of the said application must serve on or send by post to the abovenamed Australian Government Solicitor notice in writing of his intention to do so. The

notice must state the name and address of the person, or, if a firm, the name and address of the firm, and must be signed by the person or firm, or his or their solicitor (if any), and must be served, or if posted, must be sent by post in sufficient time to reach the abovenamed Australian Government Solicitor not later than 4.00 p.m. on 29 May 1985. 7888

In the Supreme Court of Victoria—Co. 244—In the matter of the Companies (Victoria) Code; and in the matter of Super-Seeds Proprietary Limited.

Notice is hereby given that an application for the winding up of the abovenamed company by the Supreme Court was on 24 April 1985 presented by James Edward McTigue, Deputy Commissioner of Taxation of the Commonwealth of Australia and that the said application is directed to be heard before the Court sitting at the Fifteenth Court, Law Courts, Lonsdale Street, Melbourne at 10.30 a.m. on 30 May 1985 and any creditor or contributory of the said company desiring to support or oppose the making of an order on the said application may appear at the time of hearing by himself or his Counsel for the purpose; a copy of the said application will be furnished to any creditor or contributory of the said company requiring the same by the undersigned on payment of the regulated charge for the same.

The applicant's official address is: 350 Collins Street, Melbourne.

The applicant's solicitor is: Australian Government Solicitor, of 200 Queen Street, Melbourne.

Note: Any person who intends to appear on the hearing of the said application must serve on or send by post to the abovenamed Australian Government Solicitor notice in writing of his intention to do so. The notice must state the name and address of the person, or, if a firm, the name and address of the firm, and must be signed by the person or firm, or his or their solicitor (if any), and must be served, or if posted, must be sent by post in sufficient time to reach the abovenamed Australian Government Solicitor not later than 4.00 p.m. on 29 May 1985. 7889

In the matter of the *Co-operative Housing Societies Act* 1958, and the Companies (Victoria) Code; and in the matter of Laverton (No. 2) Co-operative Housing Society Limited (In Liquidation)—Notice to Creditors

Notice is hereby given that all persons having any claim against the above society are required on or before 27 May 1985 to send their names and addresses and particulars of their debts or claims to Kevin Edward Palmer of 423 Bourke Street, Melbourne the liquidator of the said society at his office and if so required by notice in writing from the said liquidator are personally, or by their solicitors, to come in and prove their said debts or claims at such time and place as shall be specified in such notice; or, in default thereof, they shall be excluded from the benefit of any distribution made before such debts or claims are so lodged or proved.

Dated at Melbourne, 26 April 1985

7907 KEVIN EDWARD PALMER, Liquidator

In the Supreme Court of Victoria—Co. 245—In the matter of the Companies (Victoria) Code; and in the matter of Maldon Investments Pty. Ltd.

Notice is hereby given that an application for the winding up of the abovenamed company by the Supreme Court was on 24 April 1985 presented by James Edward McTigue, Deputy Commissioner of Taxation of the Commonwealth of Australia and that the said application is directed to be heard before the Court sitting at the Fifteenth Court, Law Courts, Lonsdale Street, Melbourne at 10.30 a.m. on 30 May 1985 and any creditor or contributory of the said company desiring to support or oppose the making of an order on the said application may appear at the time of hearing by himself or his Counsel for the purpose; a copy of the said application will be furnished to any creditor or contributory of the said company requiring the same by the undersigned on payment of the regulated charge for the same.

The Applicant's official address is: 350 Collins Street, Melbourne.

The Applicant's Solicitor is: Australian Government Solicitor, of 200 Queen Street, Melbourne.

Note: Any person who intends to appear on the hearing of the said application must serve on or send by post to the abovenamed Australian Government Solicitor notice in writing of his intention to do so. The notice must state the name and address of the person, or, if a firm, the name and address of the firm, and must be signed by the person or firm, or his or their solicitor (if any), and must be served, or if posted, must be sent by post in sufficient time to reach the abovenamed Australian Government Solicitor not later than 4.00 p.m. on 29 May 1985. 7884

In the Supreme Court of Victoria—Co. 246—In the matter of the Companies (Victoria) Code; and in the matter of Superplan Pty. Ltd.

Notice is hereby given that an application for the winding up of the abovenamed company by the Supreme Court was on 24 April 1985 presented by James Edward McTigue, Deputy Commissioner of Taxation of the Commonwealth of Australia and that the said application is directed to be heard before the Court sitting at the Fifteenth Court, Law Courts, Lonsdale Street, Melbourne at 10.30 a.m. on 30 May 1985 and any creditor or contributory of the said company desiring to support or oppose the making of an order on the said application may appear at the time of hearing by himself or his Counsel for the purpose; a copy of the said application will be furnished to any creditor or contributory of the said company requiring the same by the undersigned on payment of the regulated charge for the same.

The Applicant's official address is: 350 Collins Street, Melbourne.

The Applicant's Solicitor is: Australian Government Solicitor, of 200 Queen Street, Melbourne.

Note: Any person who intends to appear on the hearing of the said application must serve on or send by post to the abovenamed Australian Government Solicitor notice in writing of his intention to do so. The notice must state the name and address of the person, or, if a firm, the name and address of the firm, and

must be signed by the person or firm, or his or their solicitor (if any), and must be served, or if posted, must be sent by post in sufficient time to reach the abovenamed Australian Government Solicitor not later than 4.00 p.m. on 29 May 1985. 7885

In the Supreme Court of Victoria—Co. 241—In the matter of the Companies (Victoria) Code; and in the matter of Tilbury and Lewis Proprietary Limited.

Notice is hereby given that an application for the winding up of the abovenamed company by the Supreme Court was on 24 April 1985 presented by James Edward McTigue, Deputy Commissioner of Taxation of the Commonwealth of Australia and that the said application is directed to be heard before the Court sitting at the Fifteenth Court, Law Courts, Lonsdale Street, Melbourne at 10.30 a.m. on 30 May 1985 and any creditor or contributory of the said company desiring to support or oppose the making of an order on the said application may appear at the time of hearing by himself or his Counsel for the purpose; a copy of the said application will be furnished to any creditor or contributory of the said company requiring the same by the undersigned on payment of the regulated charge for the same.

The Applicant's official address is: 350 Collins Street, Melbourne.

The Applicant's Solicitor is: Australian Government Solicitor, of 200 Queen Street, Melbourne.

Note: Any person who intends to appear on the hearing of the said application must serve on or send by post to the abovenamed Australian Government Solicitor notice in writing of his intention to do so. The notice must state the name and address of the person, or, if a firm, the name and address of the firm, and must be signed by the person or firm, or his or their solicitor (if any), and must be served, or if posted, must be sent by post in sufficient time to reach the abovenamed Australian Government Solicitor not later than 4.00 p.m. on 29 May 1985. 7886

Australia and New Zealand Banking Group Limited of 55 Collins Street, Melbourne in the State of Victoria hereby gives notice that on 12 April 1985 it appointed Colin Stanley Wight and Baard Solnordal of 20th Floor, 500 Bourke Street, Melbourne in the said State, Chartered Accountants, as Receivers and Managers of the property of Ho-Won Company Pty. Ltd. under the powers contained in an instrument dated 28 January 1985 being a Mortgage Debenture created and issued by Ho-Won Company Pty. Ltd. in favour of Australia and New Zealand Banking Group Limited and lodged in the Corporate Affairs Office No. 51319.

Dated 12 April 1985

Executed by Australia and New Zealand Banking Group Limited by being Signed Sealed and Delivered by its Attorney Ronald MacPherson Smith under Power of Attorney No. 261939 and in the presence of: (G. Cooper)

Australia and New Zealand Banking Group Limited by its Attorney (R. Smith) who certifies that he is a Senior Manager Branch Lending for the time being of Australia and New Zealand Banking Group Limited in Victoria 7870

In the Supreme Court of Victoria 1985—Co. No. 218—
In the matter of the Companies (Victoria) Code; and
in the matter of Corporate Air Conditioning Pty.
Ltd.

Notice is hereby given that a petition for the winding-up of the abovenamed company by the Supreme Court was on 11 April 1985 presented by H. J. Reece Pty. Ltd. whose registered office is situate at 8 Pilgrim Street, Ringwood in the State of Victoria and that the said petition is directed to be heard before the Court sitting at Melbourne at 10.30 a.m. on Thursday, 30 May 1985 at the Practice Court and any creditor or contributory of the said company desiring to support or oppose the making of an order on the said petition may appear at the time of hearing by himself or his counsel for that purpose; and a copy of the petition will be furnished to any creditor or contributory of the said company requiring the same by the undersigned on payment of the regulated charge for the same.

The Petitioner's address is: 8 Pilgrim Street, Ringwood in the State of Victoria.

The Petitioner's Solicitors are: A. E. Wundele & Co., 253 Lonsdale Street, Melbourne.

A. E. WUNDELE & CO. solicitors for the petitioner

Note: Any person who intends to appear on the hearing of the said petition must serve on or send by post to the abovenamed A. E. Wundele & Co., notice in writing of his intention to do so. The notice must state the name and address of the person, or if a firm, the name and address of the firm and must be signed by the person or firm or his or their solicitor (if any) and must be served or, if posted, must be sent by post in sufficient time to reach the abovenamed not later than 4 p.m. on 29 May 1985. 7848

In the Supreme Court of Victoria 1985 Co.—No. 202—
In the matter of the Companies (Victoria) Code; and
in the matter of Air Monde Pty. Ltd.—Advertisement
of Petition

Notice is hereby given that a petition for the winding up of the abovenamed company by the Supreme Court was, on 2 April 1985 presented by Sydney Piccadilly Co. Pty. Ltd. (Trading as World Air Ticket Centre). And that the said petition is directed to be heard before the Court sitting at Melbourne at 10.30 a.m. on 9 May 1985; and any creditor or contributory of the said company desiring to support or oppose the making of an order on the said petition may appear at the time of hearing by himself or his counsel for that purpose; and a copy of the petition will be furnished to any creditor or contributory of the said company requiring the same by the undersigned upon payment of the regulated charge for the same.

The Petitioner's address is: 2 Bligh Street, Sydney, N.S.W.

The Petitioner's solicitor is: Michele Kramer of Darvall McCutcheon, 80 Collins Street, Melbourne.

DARVALL McCUTCHEON, solicitors, 80 Collins Street, Melbourne

Note: Any person who intends to appear on the hearing of the said petition must serve on or send by post to the abovenamed solicitor notice in writing of his intention so to do. The notice must state the name

and address of the person, or, if a firm, the name and address of the firm, and must be signed by the person or firm, or his or their solicitor (if any), and must be served, or, if posted, must be sent by post in sufficient time to reach the abovenamed not later than 4.00 p.m. on 8 May 1985. 7849

In the Supreme Court of Victoria 1985—Co. No. 47—
In the matter of the Companies (Victoria) Code; and
in the matter of Amaca Enterprises Pty. Ltd.—
Advertisement of Application

Notice is hereby given that an application for the winding up of the abovenamed company by the Supreme Court was on 24 April 1985 presented by Citicorp Australia Limited and that the said application is directed to be heard before the court sitting at the Practice Court, Law Courts, Lonsdale Street, Melbourne at 10.30 a.m. on 6 June 1985 and any creditor or contributory of the said company desiring to support or oppose the making of an order on the said application may appear at the time of hearing by himself or his counsel for the purpose; and a copy of the said application will be furnished to any creditor or contributory of the said company requiring the same by the undersigned on payment of the registered charge for the same.

The Applicant's official address is: 63 Exhibition Street, Melbourne in the State of Victoria.

The Applicant's Solicitor is: William Weston of 27 Windsor Place, Melbourne in the State of Victoria.

Dated 24 April 1985

WILLIAM WESTON

Note: Any person who intends to appear on the hearing of the said Application must serve on or send by post to the abovenamed William Weston notice in writing of his intention so to do. The notice must state the name and address of the person, or, if a firm, the name and address of the firm, and must be signed by the person or firm, or his, or their solicitors (if any), and must be served, or, if posted, must be sent by post in sufficient time to reach the abovenamed not later than 4.00 p.m. on 5 June 1985 7909

In the Supreme Court of Victoria—Co. 128—In the
matter of the Companies (Victoria) Code; and in the
matter of Great Gippsland Farms Proprietary
Limited—Notice of Winding Up Order
Winding up Order: Made 18 April 1985

Name and address of Liquidator: K. J. Russell, State Bank Building, 385 Bourke Street, Melbourne, Vic., 3000.

AUSTRALIAN GOVERNMENT SOLICITOR,
solicitor for the applicant 7879

In the Supreme Court of Victoria—Co. 144—In the
matter of the Companies (Victoria) Code; and in the
matter of Edwards and Donohue Sports Pty. Ltd.—
Notice of Winding Up Order
Winding up Order: Made 18 April 1985

Name and address of Liquidator: R. E. Ramsay, 1st Floor, 400 Little Collins Street, Melbourne, Vic., 3000.

AUSTRALIAN GOVERNMENT SOLICITOR,
solicitor for the applicant 7880

In the Supreme Court of Victoria—Co. 129—In the matter of the Companies (Victoria) Code; and in the matter of Lewis & Halley Proprietary Limited—Notice of Winding Up Order

Winding up Order: Made 18 April 1985

Name and address of Liquidator: Mr A. M. Horsburg, Duesburys, Wallace McMullin & Smail, 499 St. Kilda Road, Melbourne Vic. 3004

AUSTRALIAN GOVERNMENT SOLICITOR,
solicitor for the applicant 7873

In the Supreme Court of Victoria—Co. 131—In the matter of the Companies (Victoria) Code; and in the matter of Coburg Drum Fabricators Proprietary Limited—Notice of Winding Up Order

Winding up Order: Made 18 April 1985

Name and address of Liquidator: Mr W. A. Leeming, Ernst & Whinney, G.P.O. Box 67B, Melbourne Vic. 3001

AUSTRALIAN GOVERNMENT SOLICITOR,
solicitor for the applicant 7874

In the Supreme Court of Victoria—Co. 136—In the matter of the Companies (Victoria) Code; and in the matter of Global Industrial Products Pty Limited—Notice of Winding Up Order

Winding up Order: Made 18 April 1985

Name and address of Liquidator: Mr B. K. Taylor, c/o B. K. Taylor & Co., 576 St Kilda Road, Melbourne Vic. 3004

AUSTRALIAN GOVERNMENT SOLICITOR,
solicitor for the applicant 7875

In the Supreme Court of Victoria—Co. 143—In the matter of the Companies (Victoria) Code; and in the matter of Tomes Booksellers Pty. Ltd.—Notice of Winding Up Order

Winding up Order: Made 18 April 1985

Name and address of Liquidator: Mr J. M. Poulton, Peat Marwick Mitchell & Co., 500 Bourke Street, Melbourne, Vic. 3000

AUSTRALIAN GOVERNMENT SOLICITOR,
solicitor for the applicant 7876

In the Supreme Court of Victoria 1985—Co. No. 232—In the matter of the Companies (Victoria) Code; and in the matter of Molera Pty. Ltd.

Notice is hereby given that an application for the winding up of the abovenamed company by the Supreme Court was on 19 April 1985 presented by Gersan Pty. Ltd. and that the said application is directed to be heard before the Court sitting at the Practice Court, Law Courts, Lonsdale Street, Melbourne on 30 May 1985 at the hour of 10.30 a.m. and any creditor or contributory of the said company desiring to support or oppose the making of an order on the said application may appear at the time of hearing by himself or by his counsel for that purpose; and a copy of the said application will be furnished to any creditor or contributory of the said company requiring the same by the undersigned on payment of the regulated charge for the same.

The applicant's official address is: Unit 8 "Alma", 663 Victoria Street, Abbotsford, Victoria.

The applicants solicitor's are: Messrs Price & Chamberlin, Brent & Stephens of 160 Queen Street, Melbourne.

PRICE & CHAMBERLIN, BRENT & STEPHENS

Note: Any person who intends to appear on the hearing of the said application must serve on or send by post to the abovenamed Price & Chamberlin, Brent & Stephens notice in writing of his intention so to do. The notice must state the name and address of the person, or if a firm, the name and address of the firm, and it must be signed by the person or the firm, or his or their solicitor (if any) and must be served, or, if posted, must be sent by post in sufficient time to reach the abovenamed not later than 4.00 p.m. on 29 May 1985 (the day before the day appointed for the hearing of the Application). 7850

R. A. STEWART PTY. LTD.

At an extraordinary general meeting of the abovenamed company duly convened and held at 10 Sans Souci Drive, Wodonga on 22 April 1985 the following resolution was duly passed as a Special Resolution:

"That the Company be wound up voluntarily as a members' voluntary winding up in accordance with the Companies (Victoria) Code and that Arthur James Hunt of 405 Warrigal Road, Burwood be appointed liquidator for the purpose of the winding up".

Notice is also given that after twenty-one days from this date I shall proceed to distribute the assets. All creditors having any claims against the Company shall furnish particulars of same by that date, otherwise I shall proceed to distribute the assets without regard to their claims.

Dated 23 April 1985

7851

A. J. HUNT, Liquidator

WARRINA PROPERTIES PTY. LTD.

At an extraordinary general meeting of the abovenamed company duly convened and held at 10 Sans Souci Drive, Wodonga on 19 April 1985 the following Resolution was duly passed as a Special Resolution:

"That the Company be wound up voluntarily as a members' voluntary winding up in accordance with the Companies (Victoria) Code and that Arthur James Hunt of 405 Warrigal Road, Burwood be appointed liquidator for the purpose of the winding up".

Notice is also given that after twenty-one days from this date I shall proceed to distribute the assets. All creditors having any claims against the Company shall furnish particulars of same by that date, otherwise I shall proceed to distribute the assets without regard to their claims.

Dated 23 April 1985

7852

A. J. HUNT, Liquidator

In the Supreme Court of Victoria—Co. 133—In the matter of the Companies (Victoria) Code; and in the matter of Coburg Containers Proprietary Limited—Notice of Winding Up Order

Winding up Order: Made 18 April 1985

Name and address of Liquidator: Mr W. A. Leeming, G.P.O. Box 67B, Melbourne

AUSTRALIAN GOVERNMENT SOLICITOR,
solicitor for the applicant 7872

In the Supreme Court of Victoria—Co. 135—In the matter of the Companies (Victoria) Code; and in the matter of Coburg Drum Manufacturers Proprietary Limited—Notice of Winding Up Order

Winding up Order: Made 18 April 1985

Name and address of Liquidator: W. A. Leeming, Ernst & Whinney, G.P.O. Box 67B, Melbourne, Vic., 3001.

AUSTRALIAN GOVERNMENT SOLICITOR,
solicitor for the applicant 7877

In the Supreme Court of Victoria—Co. 134—In the matter of the Companies (Victoria) Code; and in the matter of Coburg Tanks Proprietary Limited—Notice of Winding Up Order

Winding up Order: Made 18 April 1985

Name and address of Liquidator: W. A. Leeming, Ernst & Whinney, G.P.O. Box 67B, Melbourne, Vic., 3001.

AUSTRALIAN GOVERNMENT SOLICITOR,
solicitor for the applicant 7878

EVANS-BLAIR HOLDINGS PTY. LTD.

Notice is hereby given that, at a general meeting of members of the abovenamed company, held at 79 Mahoneys Road, Forest Hill on 19 April 1985. It was resolved that the Company be wound up voluntarily, and that Graham Burgess, chartered accountant, of 79 Mahoneys Road, Forest Hill, be appointed liquidator for the purposes of winding up.

Dated 22 April 1985

7853 A. D. EVANS, Secretary

EVANS-BLAIR PTY. LTD.

Notice is hereby given that, at a general meeting of members of the abovenamed company, held at 79 Mahoneys Road, Forest Hill on 19 April 1985. It was resolved that the company be wound up voluntarily, and that Graham Burgess, chartered accountant, of 79 Mahoneys Road, Forest Hill, be appointed liquidator for the purposes of the winding-up.

Dated 22 April 1985

7854 A. D. EVANS, Secretary

EVANS-BLAIR CONTRACTING PTY. LTD.

Notice is hereby given that, at a general meeting of members of the abovenamed company, held at 79 Mahoneys Road, Forest Hill on 19 April 1985. It was resolved that the company be wound up voluntarily, and that Graham Burgess, chartered accountant, of 79

Mahoneys Road, Forest Hill, be appointed liquidator for the purposes of the winding up.

Dated 22 April 1985

7855 A. D. EVANS, Secretary

In the Supreme Court of Victoria—Co. 132—In the matter of the Companies (Victoria) Code; and in the matter of Coburg Reconditioners Proprietary Limited—Notice of Winding Up Order

Winding up Order: Made 18 April 1985

Name and address of Liquidator: Mr W. A. Leeming, G.P.O. Box 67B, Melbourne

AUSTRALIAN GOVERNMENT SOLICITOR,
solicitor for the applicant 7871

THELMA ROSE WORTLEY, late of 30 Carn Avenue, Ivanhoe, married woman, deceased

Creditors, next of kin and others having claims in respect of the estate of the deceased who died on 28 November 1984, are required by The Perpetual Executors and Trustees Association of Australia Limited of 50 Queen Street, Melbourne and Sidney Walwyn Wortley of 30 Carn Avenue, Ivanhoe, director and Janet Rose Whitford of 25 Grace Avenue, Beecroft, New South Wales the applicants for a grant of administration to send particulars of their claims to the said applicants in the care of the said company by 4 July 1985 after which date they will convey or distribute the assets having regard only to the claims of which they then have notice.

ARTHUR ROBINSON & HEDDERWICKS,
solicitors, 121 William Street, Melbourne 7930

JEAN HEATHER HUNTER, late of 6 Snooks Court, Middle Brighton, widow, deceased

Creditors, next of kin and others having claims against the estate of the said deceased who died on 19 December 1984 are to send particulars of their claims to Anthony Neil Hunter and Mary Jean Garonne Kamat care of Messrs Blake & Riggall, solicitors, 140 William Street Melbourne by 1 August 1985 after which date they will distribute the assets having regard only to the claims of which they then have notice.

BLAKE & RIGGALL, solicitors, 140 William Street,
Melbourne, 7931

SHEILA MARY ANNE BREHENY, late of Flat 2/42 Howitt Street, South Yarra, retired, deceased

Creditors, next of kin and others having claims against the Estate of the said deceased who died on 18 January 1985 are to send particulars of their claims to Mark James Breheny (in the will called Mark Breheny) and Micheal Xavier Henderson (in the will called Michael Henderson) care of Messrs Blake & Riggall, Solicitors, 140 William Street, Melbourne by 1 August 1985 after which date they will distribute the assets having regard only to the claims of which they then have notice.

BLAKE & RIGGALL, solicitors, 140 William Street,
Melbourne 7932

Creditors, next of kin and others having claims in respect of the estate of Joice Mary Loch, late of Prosforion via Errisos, Chalkhidiki, Greece, widow, who died on 8 October 1982 are required by Howard David Bear of 337 La Trobe Street, Melbourne, solicitor the proven administrator of the estate to send particulars to him by 2 July 1985 after which date he may convey or distribute the assets having regard only to the claims of which he then has notice.

RYLAH & RYLAH, solicitors, 337 La Trobe Street, Melbourne 7890

Creditors, next of kin and others having claims against the estate of Ada Doris Allwright, late of Manchester Unity Aged Members Centre, Coleman Parade, Glen Waverley in the State of Victoria, spinster, deceased who died on 3 February 1985 are requested to send particulars of their claims to Leigh Foster Mumford of 21 Lillian Street, Glen Waverley in the said State and William Leslie Walmsley of 1/1 Lansell Road, Toorak in the said State care of the belowmentioned solicitors by 6 July 1985 after which date they will distribute the assets having regard only to the claims of which they then have notice.

PURVES & PURVES, solicitors, of 121 William Street, Melbourne 7891

Creditors, next of kin and others having claims in respect of the estate of Joan Emily Smith late of 8 Fyffe Street, Thornbury, deceased, invalid pensioner who died on 21 April 1985 are requested to send particulars of their claims to the executor care of the undermentioned solicitors on or before 3 July 1985 after which date they will distribute the assets having regard only to the claims of which they then have notice.

McKEAN & PARK, solicitors, 450 Little Collins Street, Melbourne 7892

JOHN THYNE REID, late of 4 St. Georges Court, 290 Cotham Road, Kew, Victoria, company director, deceased

Creditors, next of kin and others having claims in respect of the estate of the deceased, who died on 31 December 1984, are required by the personal representatives Gladys Violet Boyd Reid of 4 St. Georges Court, 290 Cotham Road, Kew, Victoria, John Boyd Reid of 3 Waiwera Street, McMahons Point, New South Wales and Ian Charles Ross of 24 Wimba Avenue, Kew, Victoria to send particulars to them care of T.N.D. Stevens & Co., 422 Collins Street, Melbourne by 4 July 1985 after which date the personal representatives may convey or distribute the assets of the estate, having regard only to the claims of which they then have notice.

ARTHUR ROBINSON & HEDDERWICKS, 121 William Street, Melbourne 7893

Creditors, next of kin or others having claims in respect of the estate of Lester Gordon Alexander Lewis late of 7/19 Snowden Avenue, Caulfield in the State of Victoria, pensioner, deceased who died on 25 February 1985 are requested to send particulars of their claims to the administratrix care of the undermentioned

solicitors by 30 June 1985 after which date the executrix will distribute the assets having regard only to the claims of which she then has notice.

RIDGEWAY CLEMENTS, solicitors, 221 Glenhuntly Road, Elsternwick 7864

Creditors, next of kin and others having claims in respect of the estate of Raymond Michel Comty late of Flat 10, 317 Inkerman Street, East St. Kilda in the State of Victoria, electrician, deceased are required by the Administrator of the estate Joseph Serge Comty to send particulars of their claims to the undersigned on or before 1 July 1985 after which date he will distribute the assets having regard to the claims of which he has notice.

Dated 24 April 1985

EDWARD J. GILES, solicitor, 141A Chapel Street, St. Kilda 7865

PHYLLIS LEWIS, late of 4 Myrtle Street, Bentleigh, Victoria, married woman, deceased

Creditors, next of kin and others having claims in respect of the estate of the abovenamed deceased who died on 27 February 1985 are required by the applicant for a Grant of Probate of the deceased's will dated 7 June 1984 namely Robert Sydney Hart of 43 Pinehill Drive, Frankston, Victoria, company director, to send particulars to his solicitors Messrs N. D. Kelly & Associates at 437 Centre Road, Bentleigh, Victoria by 3 July 1985 after which date the said Robert Sydney Hart may convey or distribute the assets having regard only to the claims of which he or the said solicitors then have notice.

N. D. KELLY & ASSOCIATES, 437 Centre Road, Bentleigh 7866

Creditors, next of kin or others having claims in respect of the estate of George Bryant Rees formerly of 6 Pleasant Court, Numurkah, but late of 4 Lyrebird Drive, Carrum Downs, builder, deceased who died on 7 October 1983 are to send particulars of their claims to the Executors care of the undermentioned solicitors by 3 July 1985 after which date the Executors will distribute the assets having regard only to the claims of which they then have notice.

MORRISON AND SAWERS, Kyabram, solicitors for the applicants 7923

Creditors, next of kin and others having claims against the estate of Pawel Shishkin, late of 12 View Road, Bayswater, gentleman, deceased who died on 16 February 1985, are required by Edward Klimetzki of 36 Rostrevor Parade, North Box Hill, retired gentleman and Gregor Romanenko of 14 Parker Street, Springvale South, retired gentleman, the executors named in the Will of the said Pawel Shishkin deceased to send particulars of their claim to the said executors care of the undermentioned solicitor by 9 July 1985, after which date the executors will convey or distribute the estate of the said deceased having regard only to the claims of which they then have notice.

M. J. REDFERN, solicitor, 463A Whitehorse Road, Balwyn, 3103 7924

GEORGE ANDERSON JONES, late of 321 Eureka Street, Ballarat, pensioner, deceased who died on 4 April 1985

Creditors, next of kin and all persons having claims against the estate of the deceased, are required to send particulars to the Executors Neil William Titheridge and Peter George Titheridge both of 50 Main Road, Ballarat at care of their solicitor Sutton & O'Loughlin, 14 Dawson Street South, Ballarat on or before 28 June 1985 after which date they will distribute the assets having regard only to the claims of which they shall then have notice.

SUTTON & O'LOUGHLIN, solicitors, 14 Dawson Street South, Ballarat 7910

FRANK HOWARD REID, late of 15 Fraser Street, Herne Hill, Geelong, labourer, deceased

Creditors, next of kin and others having claims in respect of the estate of the deceased who died on 15 January 1985 are requested to send particulars of their claims to the executrix Lorna Reid care of the undersigned solicitors by 15 July 1985 after which date the Executrix will proceed to distribute the estate having regard only to the claims of which she then has notice.

BURKE COX & CO., solicitors, 111 Yarra Street, Geelong 7911

LAURENCE BALDWIN, late of 28 Edgecliff Avenue, South Coogee, New South Wales, retired general manager, deceased

Creditors, next of kin and others having claims in respect of the estate of the abovenamed deceased, who died on 18 September 1984, are required by the Executrix of the Estate Laurel May Baldwin of 28 Edgecliff Avenue, South Coogee, in the said State, to send particulars of their claims to her care of the undersigned solicitors by 1 July 1985 after which date the said Executrix may distribute the assets having regard only to claims of which she then has notice.

CLAYTON UTZ, solicitors, 35 Collins Street, Melbourne 7912

Creditors, next of kin and others having claims in respect of the estate of Anita Sonja Donnini, late of Falloons Road, Woodend, married woman, deceased, who died on 30 March 1985 and by whose will, James William Noy, solicitor, John Francis Scott, funeral director, both of Kyneton, and Bertha Danylo, of Falloons Road, Woodend, widow, were appointed executors are required to send particulars of their claims to the said executors care of the undersigned solicitors before 3 July 1985, after which date they will distribute the assets having regard only to the claims of which they shall then have had notice.

PALMER, STEVENS & RENNICK, solicitors, Kyneton 7913

Creditors, next of kin and others having claims in respect of the Estate of Anne Goodwin Hickling late of 7 Beckley Street, East Coburg, widow who died on 5 July 1984 are to send particulars of their claim to Marguerite Young the administratrix care of the

undersigned by 26 June 1985 after which date she will commence to distribute the assets having regard only to the claims of which she then has notice.

RENNICK & GAYNOR, solicitors, of 530 Little Collins Street, Melbourne or 427 Riversdale Road, Hawthorn East 7932

MARK LINDSAY GAMBLE late of 80 Sackville Street, Montmorency, Victoria and also of 5-7 RAR Milpo, Holsworthy, New South Wales, army private, deceased

Creditors, next of kin and other having claims in respect of the estate of the said deceased who died on 7 September 1984 are required to send particulars of their claims to Keith Gordon Gamble and Shirley Ann Gamble care of Messrs W. Carew Hardham & Gartlan, solicitors of 974 Main Road Eltham, Victoria by 5 July 1985 after which date they will distribute the assets having regard only to the claims of which they then have notice.

W. CAREW HARDHAM & GARTLAN, solicitors of 974 Main Road, Eltham 7914

Creditors, next of kin and others having claims in respect of the estate of Doris Vera McIntosh late of 759 Burwood Road, Hawthorn in the State of Victoria, widow, deceased who died on 19 February 1985 are required by the Executor Kenneth Edgar Toop of 150 Queen Street, Melbourne, solicitor to send particulars of their claims to the said Executor care of the under-mentioned solicitors by 16 July 1985 after which date the said Executor may convey or distribute the assets having regard only to the claims of which he then has notice.

E. A. ATKYNS & TOOP, solicitors, 150 Queen Street, Melbourne 7915

Creditors, next of kin or others having claims in respect of the estate of Margery Agnes Carlson late of Unit 3, 689 Hampton Street, Brighton, widow, deceased who died on 29 January 1985 are requested to send particulars of their claims to The National Trustees Executors and Agency Company of Australasia Limited of 95 Queen Street, Melbourne by 15 July 1985 after which date it will distribute the assets having regard only to the claims of which it then has notice.

RIDGEWAY CLEMENTS, solicitors, 221 Glenhuntly Road, Elsternwick 7916

Creditors, next of kin and others having claims against the estate of Cyril James Mongor late of 33 Rusden Street, Elsternwick, in the State of Victoria, gentleman, deceased (who died on 4 June 1984) are to send particulars of their claims to Patricia Mary Carroll of 95 Queen Street, Melbourne, the Executrix, before 3 July 1985 after which date she will distribute the assets of the estate having regard only to the claims for which she then has notice.

JOHN F. CARROLL, solicitor, 95 Queen Street, Melbourne 7917

MARJORIE EDGERTON, late of 508 Glen Eira Road, Caulfield, in the State of Victoria, widow

Creditors, next of kin and others having claims in respect of the estate of the deceased who died on 19 January 1985, are required by the Trustee, The Equity Trustees Executors and Agency Company Limited of 472 Bourke Street, Melbourne, Victoria, to send particulars to it by 2 July 1985, after which date the Trustee may convey or distribute the assets having regard only to the claims of which it then has notice.

Dated 24 April 1985

CHAMBERS, MOORE & CO., 30-44 Chetwynd Street, West Melbourne, solicitors for the executors
7926

DOROTHY GILLIGAN, late of Denbies Private Nursing Home, 1083 Glenhuntly Road, Glenhuntly, deceased

Creditors, next of kin and others having claims in respect of the estate of the deceased who died on 14 January 1985 are required by Bernard Sutcliffe Gilligan of 11 Mulgoa Road, Brighton the Executor to whom Probate of the Will of the said deceased was granted by the Supreme Court of Victoria to send particulars care of the undersigned by 6 July 1985 after which date the said Executor may convey or distribute the assets having regard only to the claims of which he then has notice.

PATRICK J. CANNON, COBURN & ASSOCIATES, solicitors, 117 Durham Road, Sunshine
7927

FREDERICK NORMAN ADAMS, late of 25 Thorndon Drive, St. Albans, in the State of Victoria, engineer, deceased

Creditors, next of kin and others having claims in respect of the estate of the deceased who died on 7 October 1984 are required by Norman Keith Adams of 29 Thorndon Drive, St. Albans in the said State, sales manager, the Administrator to whom Letters of Administration with the Will annexed of the deceased were granted by the Supreme Court of Victoria to send particulars care of the undersigned by 17 July 1985 after which date the said Administrator may convey or distribute the assets having regard only to the claims of which he then has notice.

PATRICK J. CANNON, COBURN AND ASSOCIATES, solicitors, of 117 Durham Road, Sunshine
7928

Creditors, next of kin, and others having claims in respect of the estate of Kathleen Ada Gilbert late of 2 Caroline Street, Hawthorn East, spinster who died on 1 February 1985 are required to send particulars of their claims to National Trustees Executors & Agency Co. of Australasia Ltd. of 95 Queen Street, Melbourne by 29 June 1985 after which date the said executor will distribute the assets having regard only to the claims of which it then has notice.

MAURICE BLACKBURN & CO., solicitors, 150 Lonsdale Street, Melbourne
7856

Creditors, next of kin and others having claims in respect of the estate of Thelma Dorothy Gardiner, formerly of 17 West Street, Brunswick but late of 14 Orient Grove Brunswick, married woman, deceased, who died on 14 October 1984 are to send particulars of their claims to the executor Edna May McKenzie care of the undermentioned solicitors by 8 July 1985 after which date the executor will distribute the assets having regard only to the claims of which she then has notice.

LE GRAND, RANGLES, ADAMS & CO., solicitors,
636 Sydney Road, Brunswick 3056
7925

Form 22

Bankruptcy Act 1966

BANKRUPTCY DISTRICT OF THE STATE OF VICTORIA

PASQUALE BARBARO

No. 86 of 1984

Notice of Intention to Declare Final Dividend

I, Edward Peter Taylor, the trustee of the estate of the abovenamed bankrupt, now give notice in pursuance of section 145 of the *Bankruptcy Act* 1966 of my intention to declare a final dividend in the estate.

Persons claiming to be creditors of the abovenamed bankrupt must prove their debt on or before 3 May 1985 or they will be excluded from the final dividend.

E. P. TAYLOR, trustee, 583 Hampton Street, Hampton. Phone: 598 7077
7846

Form 42

Bankruptcy Act 1966

BANKRUPTCY DISTRICT OF THE STATE OF VICTORIA

PASQUALE BARBARO

No. 86 of 1984

Take notice that a meeting of the creditors of Pasquale Barbaro of 28 Vera Street, Glenroy will be held at the offices of Phillip Adami, Joseph Melilli, solicitors of 159 Sydney Road, Coburg at 10.30 a.m. on 29 April 1985.

Agenda

1. To set the remuneration of the Trustee in accordance with the provisions of the *Bankruptcy Act* 1966 at the lump sum of \$3500

2. To provide information as to the conduct of the affairs of the bankrupt.

Dated 19 April 1985

E. P. TAYLOR, trustee, 583 Hampton Street, Hampton. Phone: 598 7077
7847

In the Supreme Court of the State of Victoria

SALE BY THE SHERIFF

On 30 May 1985 at 2.30 p.m. at 287 Springvale Road, Glen Waverley (unless process be stayed or satisfied).

All the estate and interest (if any) of Charles Victor Bortham and Elisabeth Anne Northam of 1329 Burke Road, East Kew as joint proprietors of an estate in fee simple in the land described in Certificate of Title

Volume 5554 Folio 607 upon which is erected a dwelling house known as 1329 Burke Road, East Kew.

Registered Mortgages Nos. G739031, and G751261, and Caveats G862434 and K247121 affect the said estate and interest.

Terms—Cash Only

7934 A. STANLEY, Sheriff's Officer

In the Supreme Court of the State of Victoria

SALE BY THE SHERIFF

On 6 June 1985 at 2.30 p.m. at 287 Springvale Road, Glen Waverley (unless process be stayed or satisfied).

All the estate and interest (if any) of Frank Todisco of 11 Lang Street, Beaumaris as joint proprietor with Antoinetta Todisco of an estate in fee simple in the land described in Certificate of Title Volume 9246 Folio 612 upon which is erected a contemporary style home with garage and inground swimming pool known as No. 11 Lang Street, Beaumaris.

Registered Mortgage Nos. L181373Y and L394504V affect the said estate and interest.

Terms—Cash Only

7935 A. STANLEY, Sheriff's Officer

In the Supreme Court of the State of Victoria

SALE BY THE SHERIFF

On 6 June 1985 at 2.30 p.m. at 287 Springvale Road, Glen Waverley (unless process be stayed or satisfied).

All the estate and interest (if any) of James Francis Walsh of 10 Byron Street, Ringwood (shown on Title as James Walsh) as proprietor of an estate in fee simple in the land described in Certificate of Title Volume 8939 Folio 507 which is vacant land known as Lot 14, Seventh Avenue, Rosebud.

Terms—Cash Only

7936 A. STANLEY, Sheriff's Officer

In the Supreme Court of the State of Victoria

SALE BY THE SHERIFF

On 5 June 1985 at 12.00 noon at Birregurra Police Station (unless process be stayed or satisfied).

All the estate and interest (if any) of Arthur Robert Lyster of 30 Keith Avenue, Edithvale, as proprietor of an estate in fee simple in the land described in Certificate of Title Volume 8174 Folio 724 upon which is erected a weatherboard dwelling and outbuildings and is located on the north side of Jenner Street, Birregurra, 264 feet west of the north-western corner of Jenner Street and Austin Street.

Registered Caveat No. G745436 affect and said estate and interest.

Terms—Cash Only

7937 A. STANLEY, Sheriff's Officer

In the Supreme Court of the State of Victoria

SALE BY THE SHERIFF

On 1 June 1985 at 2.30 p.m. at 287 Springvale Road, Glen Waverley (unless process be stayed or satisfied).

All the estate and interest (if any) of Maree Beugellar (shown on Title as Maree Antionette Beugelaar) of 10 Barnett Grove, Noble Park and joint proprietor with Jurie Nicholas Beugelaar of an estate in fee simple in the land described in Certificate of Title Volume 8312 Folio 193 upon which is erected a dwelling house known as 10 Barnett Grove, Noble Park.

Terms—Cash Only

7938 A. STANLEY, Sheriff's Officer

LATE NOTICES

Public Service Act 1974

QUEEN'S BIRTHDAY HOLIDAY 1985

PROCLAMATION

By His Excellency the Governor of the State of Victoria and its Dependencies in the Commonwealth of Australia, &c., &c., &c.

In pursuance of the powers conferred by sub-section (1) (e) of section 71 of the *Public Service Act 1974*, I the Governor of the State of Victoria, in the Commonwealth of Australia, by and with the advice of the Executive Council of the said State, do by this my Proclamation appoint Monday, 10 June 1985 as the day upon which the Anniversary of the birthday of Her Majesty for the year 1985 shall be observed as a holiday in the public offices throughout the State of Victoria.

Given under my Hand and the Seal of the State of Victoria aforesaid, at Melbourne, this thirtieth day of April in the year of our Lord One thousand nine hundred and eighty-five and in the thirty-fourth year of the reign of Her Majesty Queen Elizabeth the Second, Queen of Australia.

(L.S.)

B. S. MURRAY

By His Excellency's Command

S. M. CRABB

Minister for Employment and Industrial Affairs

GOD SAVE THE QUEEN!

Bank Holidays Act 1958

QUEEN'S BIRTHDAY HOLIDAY 1985

PROCLAMATION

By His Excellency the Governor of the State of Victoria and its Dependencies in the Commonwealth of Australia, &c., &c., &c.

In pursuance of the powers conferred by the *Bank Holidays Act 1958*, I, the Governor of the State of Victoria, in the Commonwealth of Australia, do by this my Proclamation appoint Monday, 10 June 1985 as the day upon which the Anniversary of the birthday

of Her Majesty for the year 1985 shall be observed as a Bank Holiday throughout the State of Victoria.

Given under my Hand and the Seal of the State of Victoria aforesaid, at Melbourne, this thirtieth day of April in the year of our Lord One thousand nine hundred and eighty-five and in the thirty-fourth year of the reign of Her Majesty Queen Elizabeth the Second, Queen of Australia.

(L.S.) B. S. MURRAY

By His Excellency's Command

S. M. CRABB
Minister for Employment and Industrial Affairs

GOD SAVE THE QUEEN!

Bank Holidays Act 1958
BANK HALF-HOLIDAY

PROCLAMATION

By His Excellency the Governor of the State of Victoria and its Dependencies in the Commonwealth of Australia, &c., &c., &c.

In pursuance of the powers conferred by the *Bank Holidays Act 1958*, I, the Governor of the State of Victoria, in the Commonwealth of Australia, do by this my Proclamation appoint the day and date mentioned hereunder to be observed as a Bank Half-Holiday at the place respectively specified:

Bank Half-Holiday from the Hour of Eleven a.m.

Thursday, 2 May 1985 throughout the Borough of Koroit.

Given under my Hand and the Seal of the State of Victoria aforesaid, at Melbourne, this thirtieth day of April in the year of our Lord One thousand nine hundred and eighty-five and in the thirty-fourth year of the reign of Her Majesty Queen Elizabeth the Second, Queen of Australia.

(L.S.) B. S. MURRAY

By His Excellency's Command

S. M. CRABB
Minister for Employment and Industrial Affairs

GOD SAVE THE QUEEN!

Cemeteries Act 1958

SCALE OF FEES OF THE BENDIGO AND WHITE HILLS PUBLIC CEMETERIES

In pursuance of the powers conferred upon them by the *Cemeteries Act* the trustees of the Bendigo and White Hills Public Cemeteries hereby make the following scale of fees, which shall come into operation upon publication in the *Government Gazette* and from and after such publication every scale of fees heretofore made by the said trustees shall be and is hereby rescinded to the extent to which it conflicts with this scale.

Public Graves

\$

Interment in grave without exclusive right—		
Child under three years, including stillborn	27.50	
Other	185.00	

Private Graves

	<i>Right of Burial Fee</i>	<i>Interment Fee</i>
Land 2.44 m × 1.22 m for two interments—	\$	\$
Lawn Section (bronze plaque memorial only as supplied by the Trust—cost additional)	375.00	185.00
Monumental Section	375.00	185.00
<i>Reopening Charges—Lawn and Monumental Sections</i>		
Reopening grave—interments Monday to Friday		253.00
Reopening grave—Saturday morning or gazetted holidays		352.00

Miscellaneous Charges

Exhumation Fee	473.00
Shape grave for rectangular coffin (extra)	55.00
Interment of cremated remains	60.00
Maintenance of grave (optional)—	
Annual charge	33.00
Annual charge with monumental ledger or slab	21.00
Twenty-five years maintenance	935.00
Monumental work permit—contract price under \$700	55.00
contract price \$700 and over	88.00
Extra sinking charge per 0.3048 m	55.00
Grave bricking fee	55.00

Memorials

Wall niche with memorial plate, as supplied by Trust	165.00
Rose garden memorial (memorial plates are placed in a position around the perimeter of a bed of selected roses)	215.00

Tenure of Memorial

Niches are leased for a period of 50 years.
Rose garden memorials are leased of a period of 25 years.

The purchaser (or descendants) has the option of renewal at the expiration of the specified period, the lease of which commences from the date of erection of memorial.

COUNCILLORS OF THE CITY OF BENDIGO

Approved by the Governor in Council, 23 April 1985—L. G. HOUSTON, Clerk of the Executive Council

Cemeteries Act 1958

SCALE OF FEES OF THE AXEDALE CEMETERY

In pursuance of the powers conferred upon them by the *Cemeteries Act 1958*, the trustees of the Axedale Public Cemetery hereby make the following scale of fees, which shall come into operation upon publication in the *Government Gazette*, and from and after such publication every scale of fees heretofore made by the said trustees shall be and is hereby rescinded to the extent to which it conflicts with this scale.

<i>Public Graves</i>	
	\$
Interment in Grave without exclusive right— Stillborn child	30.00
Interment in Grave without exclusive right— Others	50.00
Number Peg or Label	15.00
<i>Private Graves</i>	
Land, 2.44 m x 1.22 m	75.00
Own section of land (extra)	55.00
<i>Sinking Charges for Private Graves</i>	
Sinking grave 1.83 m deep	110.00
Each additional 0.3 m	25.00
Sinking oversize grave	40.00
Cancellation of order to sink (if commenced)	25.00
Reopening grave (no cover)	110.00
Reopening grave (with cover)	120.00
<i>Miscellaneous Charges</i>	
Interment fee	35.00
Interment outside prescribed hours, or on Saturdays, Sundays or Public Holidays or without due notice	45.00
Certificate of Right of Burial	10.00
Number Plate or Brick	15.00
Permission to erect a headstone or monument—5% of cost with a minimum \$15.00	
Permission to construct a brick grave or to erect any stone kerb, brick tile-work or concrete—5% of cost with a minimum \$15.00	
Exhuming the remains of a body (when authorized)	300.00
Interment of ashes in a private grave	35.00
Memorial Wall Niche and Plaque	110.00
COUNCILLORS OF THE SHIRE OF STRATHFIELDSAYE	
Approved by the Governor in Council, 23 April 1985—L. G. HOUSTON, Clerk of the Executive Council	

in the *Government Gazette*, and from and after such publication every scale of fees hereto for made by the said trustees shall be and is hereby rescinded to the extent to which it conflicts with this scale.

Sinking Charges etc.

	\$
Sinking a private grave (2.13 m)	370.00
Sinking a private grave (2.74 m)	470.00
Reopening any grave or vault	370.00
Exhumation (when authorized)	600.00

Land

Private grave in denominational section for immediate need	500.00
Private grave in special locations for immediate need	550.00

Miscellaneous Charges

Interment on Saturday morning or Public Holiday (extra)	230.00
Burial in coffin over 2.06 m long or over 0.66 m wide (extra)	200.00
Burial in casket (extra)	200.00
Right of burial, transfer or duplicate certificate	20.00
Remove and replace ledger	60.00
Remove concrete and screenings	50.00

Cremated Remains

Interment of cremated remains in lawn position for 25 years tenure. (Plaque and block additional)	350.00
Interment of cremated remains in grave	150.00
Memorial rose, azalea or shrub for 12 years tenure	500.00
Additional cremated remains in lawn or garden for remainder of tenure	200.00
Memorial wall niche and plaque for 25 years tenure	200.00
Reserve memorial niche and reservation plaque for 25 years tenure	250.00
Recondition niche or garden plaque	50.00
Remove and refit niche or garden plaque	50.00

Vaults

Concrete vaults for two burials	1500.00
---------------------------------	---------

J. F. MAUGHAN, Trustee
F. P. BYRNE, Trustee
J. B. THOMPSON, Trustee

Approved by the Governor in Council, 23 April
1985—L. G. HOUSTON, Clerk of the Executive
Council

Cemeteries Act 1958

SCALE OF FEES OF THE BOROONDARA
PUBLIC CEMETERY

In pursuance of the powers conferred upon them by the *Cemeteries Act* the trustees of the Boroondara Public Cemetery hereby make the following scale of fees, which shall come into operation upon publication

I hereby give notice that on 4 April 1985, the Public Trustee filed an Election to Administer the following deceased person's estate in accordance with section 17 of the *Public Trustee Act 1958*:

Taylor, Charlotte, formerly of Flat 50, 200 Pascoe Vale Road, Essendon but late of Flat 50, 1 Moreland Road, Lionsville, Essendon, spinster, died 8 February 1985.

I hereby give notice that on 16 April 1985, the Public Trustee filed Elections to Administer the following deceased persons' estates in accordance with section 17 of the *Public Trustee Act 1958*:

Bown, John Edward, late of Flat 8, 18 Miller Street, North Fitzroy, pensioner, died 5 March 1985.

Crosbie, Frederick Gerald, late of 83 Eglinton Street, Moonee Ponds, gentleman, died 27 February 1985.

Keating, Marguerite Elizabeth, formerly of 11 Richmond Terrace, Richmond, but late of Banksia Court, Private Nursing Home, 391-393 Maroondah Highway, Croydon, pensioner, died 27 January 1985.

Miller, Thomas, late of Flat 3, 9 Wando Grove, East St. Kilda, pensioner, died 14 December 1984.

Pearce, Horace Clyde, late of 4 Ethel Street, Wodonga, pensioner, died 8 January 1985.

Sefton, Marjorie Jessie, also known as Marjorie Sefton, formerly of 33 Havelock Street, St. Kilda, but late of Jenmar Private Nursing Home, 2 Chilcote Avenue, Malvern, widow, died 28 February 1985.

Thomas, Ronald Selwyn, late of Kingston Centre Geriatric Hospital, Warrigal Road, Cheltenham, pensioner, died 22 December 1984.

Wallace, Valda Clarice, also known as Balda Clarice Wallace, late of Ballarat, pensioner, died 26 November 1984.

Wilson, Evelyn Ruth, late of Ballarat, pensioner, died 29 January 1985.

Whitehead, James Alexander, formerly of 83 Woodland Street, Essendon, but late of Centennial House, 15 Raleigh Street, Windsor, retired railways employee, died 5 September 1976.

Whitmore, Robert Alexander, formerly of 34 Athol Street, Moonee Ponds, but late of Flat 2, 5 Dunlop Street, Ascot Vale, retired electrical mechanic, died 8 February 1985.

Dated 24 April 1985

P. T. SPENCER
Public Trustee

APPOINTMENT

His Excellency the Governor of the State of Victoria by and with the advice of the Executive Council thereof has by Order made on 30 April 1985 been pleased to make the undermentioned appointment, viz:

Law Department

Judge of the Supreme Court

Frank Hollis Rivers VINCENT, Q.C., a practitioner of the Court of not less than eight years, to be a Judge of the Supreme Court of Victoria pursuant to the provisions of section 5 of the *Constitution Act 1975*.

L. G. HOUSTON

Clerk of the Executive Council

At the Executive Council Chamber
Melbourne, 30 April 1985

I hereby give notice that on 19 April 1985, the Public Trustee filed Elections to administer the following deceased persons' estates in accordance with section 17 of the *Public Trustee Act 1958*:

Boyd, Leonard George, late of 2/54 Chaucer Street, St. Kilda, retired, died 9 February 1985.

Cardell, Robert, formerly of 2 Liardet Street, Port Melbourne, but late of Centennial House, K15 Raleigh Street, Windsor, railway employee, died 22 February 1985.

Guslinski, Jacek, late of Flat 8, 156 Station Street, Fairfield, waiter, died 9 February 1985.

Hickman, Matilda Jane, formerly of 1 Rogers Street, Coburg, but late of Kew, widow, died 12 February 1985.

Jones, Edith Irene, formerly of Flat 4, 35 Mitford Street, St. Kilda, but late of South Port Community Nursing Home Society 18-30 Richardson Street, Albert Park, spinster, died 31 January 1985.

Morrison, Kathleen Mary, late of C/- Elanora Home and Hospital 7 Mair Street, Brighton, widow, died 16 January 1985.

Tutty, Mary Catherine, late of 11 Creswell Avenue, Niddrie, spinster, died 20 January 1985.

Vanderklift, Dirk, late of Flat 1/16 Milne Street, Seaford, engineer, died 17 March 1985.

Vickery, Horace George, formerly of 3 Westbourne Street, Prahran, but late of Mont Park, pensioner, died 15 January 1985.

NOTICE OF MAKING OF STATUTORY RULES WHICH ARE NOT YET AVAILABLE

Notice is given of the making of the following Statutory Rules:

No.	<i>Drugs, Poisons and Controlled Substances Act 1981</i>
91/1985	Proclamation
	<i>Drugs, Poisons and Controlled Substances Act 1981</i>
94/1985	Proclamation
	<i>State Electricity Commission Act 1958</i>
95/1985	State Electricity Commission Employees' Representative Regulations 1985
	<i>Adoption Act 1984</i>
96/1985	Adoption Information Regulations 1985

	<i>Optometrists Registration Act 1958</i>		<i>Groundwater Act 1969</i>
101/1985	Optometrists (Qualifications) Regulations 1985	116/1985	Groundwater (Fees) Regulations 1985
	<i>Metropolitan Fire Brigades Act 1958</i>		<i>Petroleum Act 1985</i>
102/1985	Metropolitan Fire Brigades (General) (Promotions) Regulations 1985	117/1985	Petroleum (Fees) Regulations 1985
	<i>Supreme Court Act 1958</i>		<i>Mining Development Act 1958</i>
	<i>Interpretation of Legislation Act 1984</i>	118/1985	Mining Development (State Batteries) (Fees) Regulations 1958
104/1985	Supreme Court (Miscellaneous Amendments) Rules 1985		<i>Health Act 1958</i>
	<i>Supreme Court Act 1958</i>	119/1985	Cleanliness (Foods, Drugs and Substances) (Further Amendment) Regulations 1985
	<i>Commercial Arbitration Act 1984</i>		<i>Dairy Industries Act 1984</i>
105/1985	Supreme Court (Commercial Arbitration) Rules 1985	120/1985	Dairy Industry (Quality Assurance) Regulations 1985
	<i>Supreme Court Act 1958</i>		<i>Public Service Act 1974</i>
	<i>Credit (Administration) Act 1984</i>	121/1985	Public Service Amendment Regulations (No. 4) 1985
107/1985	Supreme Court (Credit Amendment) Rules 1985		
	<i>Supreme Court Act 1958</i>		
	<i>Administration and Probate Act 1958</i>		
108/1985	Supreme Court (Administration and Probate Amendment) Rules 1985		
	<i>Supreme Court Act 1958</i>		
109/1985	Supreme Court (General Rules of Procedure in Civil Proceedings) Rules 1985		
	<i>Financial Institutions Duty Act 1982</i>		
111/1985	Financial Institutions Duty (Exemption) Regulations 1985		
	<i>Police Regulation Act 1958</i>		
112/1985	Police (Constitution Strength Organization and Seniority) (Departments) Regulations 1985		
	<i>Mines Act 1958</i>		
113/1985	Mines (Fees) Regulations 1985		
	<i>Pipelines Act 1967</i>		
114/1985	Pipeline (Fees) Regulations 1985		
	<i>Extractive Industries Act 1966</i>		
115/1985	Extractive Industries (Fees) Regulations 1985		

**NOTICE OF MAKING
AND AVAILABILITY OF
STATUTORY RULES**

In pursuance of the provisions of the *Subordinate Legislation Act 1962* and the Regulations made thereunder notice is given of the making and availability of the following Statutory Rules:

Note: The date specified after each Statutory Rule is the date it was first obtainable from the Victorian Government Bookshop, 41 St Andrew's Place, East Melbourne.

No.	Stamps Act 1958	Price
79/1985	Stamps (Amendment) Regulations 1985	
30 April 1985		60c
	<i>Supreme Court Act 1958</i>	
106/1985	Supreme Court (Division into Chapters) Rules 1985	
30 April 1985		20c
	<i>Port of Geelong Authority Act 1958</i>	
110/1985	Port of Geelong (Harbor Charges) (Amendment) Regulation 1985	
30 April 1985		20c

Publications Availability

Publications may be purchased from the **Victorian Government Bookshop**
 41 St Andrews Place East Melbourne
 (PO Box 203 North Melbourne 3051)
 Telephone Inquiries (03) 320 0299

Mail Orders and Postage

A postage and packaging fee must be added to the cost of the requested publication using the table of rates below. Remittances should be made payable to the 'Victorian Government Printing Office'.

Bankcard

Purchases may be made using Bankcard facilities in the Bookshop and by mail order. Bankcard mail orders require the Bankcard number, expiry date, name, address and signature of customer to be supplied. (Minimum purchase of \$5.00 applies).

Total Price of Publications	Postage Packaging Fee
\$ 0.00 to \$ 2.00	\$ 0.80
\$ 2.05 to \$ 5.00	\$ 1.10
\$ 5.05 to \$ 25.00	\$ 2.50
\$ 25.05 to \$ 75.00	\$ 3.00
\$ 75.05 to \$125.00	\$ 3.50
\$125.05 to \$200.00	\$ 4.00
\$200.05 and over	at cost

Agents

The following have been appointed agents to receive advertisements for the *Victoria Government Gazette*:

- Armstrong's Communications Pty Ltd
191 Queen Street Melbourne 3000
- Blane's Authorized Newsagents 162 Murray Street Colac 3250
- Cornell R G 126 Eighth Street Mildura 3500
- Franks H and Co 184 Ryrie Street Geelong 3220
- Gordon and Gotch Australasia Ltd
25-37 Huntingdale Road Burwood 3125
- Harston, Partridge & Co. Pty Ltd 455 Little Collins Street Melbourne 3000
- Kyneton Guardian Pty Ltd PO Box 18 Kyneton 3444
- The Mercantile Exchange 50 Queen Street Melbourne 3000
- Bridgemall Newsagency 63 Bridgemall Road Ballarat 3350
- McGill's Authorized Newsagency 183-185 Elizabeth Street Melbourne 3000
- McNaughton P R and L A 112-114 Gray Street Hamilton 3300
- Powney's Authorized Newsagency 293 Hargreaves Street Bendigo 3550
- Purdie J & Co. 138 Moorabool Street Geelong 3220
- Vernons of Richmond 261 Bridge Road Richmond 3121

Publication Details

The *Victoria Government Gazette* is published every Wednesday, unless otherwise advertised.

Copy Deadline

Private advertisements will be accepted by:
Gazette Advertising

Victorian Government Printing Office

PO Box 203 North Melbourne 3051, no later than 1 p.m. on the day before publication.

Advertising Rates

Single column × cm/part cm\$3.35
Double column × cm/part cm\$6.70
Full page.....\$157.50

Ordinary rates will apply to material submitted for publication before 1 p.m. Tuesday. Double rates will apply for material submitted between 1 p.m. and 3.30 p.m. Tuesday.

Advertisers should note:

- There are approximately 30 words to each column centimetre depth;
- Signatures (in particular) and proper names must be written clearly in the text;
- Advertising material should be double-spaced and confined to ONE SIDE ONLY of each sheet of paper
- Documents NOT CLEARLY PREPARED will be returned to the sender, unpublished.

Correspondence

All correspondence should be addressed to:
Gazette Advertising

Victorian Government Printing Office

PO Box 203 North Melbourne 3051
Telephone Inquiries (03) 320 0100

CONTENTS

	Page
Act of Parliament	1245
Appointments	1267
Cemeteries—Scale of Fees	1255
Contracts	1249
Estates of Deceased Persons	1266
Government Notices	1246
Late Notices	1343
Minerals and Energy	1248
Notice to Mariners	1258
Notice of Making of Statutory Rules	1346
Orders in Council—	
Acts—	
Lands; Crown Land (Reserves); Superannuation; Water; Parliamentary Committees; Urban Land Authority;	1269 et seq
Police Sale	1267
Private Advertisements	1274
Proclamation	1243
Resignations	1268
Rural Water Commission	1259
Tenders	1267,1273
Transport	1246

PREPARATION OF CRIMINAL TRIALS IN VICTORIA

The Publication "Preparation of Criminal Trials in Victoria," deals primarily with the preparation of the Crown case in a criminal trial, and for the first time provides practitioners in Victoria with an up to date practical working guide.

It is the latest in a line of legal publications published by the Victorian Government Printing Office, and is edited by Richard M Read Prosecutor for the Queen.

Preparation of Criminal Trials in Victoria will be of interest to all those concerned with the presentation of a criminal trial, and priced at only \$12.00 will provide an invaluable source of information to those within the legal profession and related fields.

SPECIAL FEATURES INCLUDE

- * A comprehensive index designed to assist practitioners who have little time to spare.
- * Chapters presented in the publication cover subjects such as The Responsibilities of the Prosecutor, Drafting Presentments, Preparation of Commercial Crime Prosecutions and many more.
- * Table of Statutes and Table of Cases.
- * Detailed Table of Contents.

Available now from the
Victorian Government Bookshop
41 St Andrews Place
(PO Box 203 North Melbourne 3051)
East Melbourne
Telephone Inquiries (03) 320 0299

**NEW
RELEASE**
\$12.00
Posted \$14.50