

PUBLISHED BY AUTHORITY



Victoria Government Gazette

No. 28—Wednesday, 23 April 1986

PROCLAMATIONS

Labour and Industry Act 1958 PROCLAMATION

PROCLAMATION

By His Excellency the Governor of the State of Victoria and its Dependencies in the Commonwealth of Australia, &c., &c., &c.

In pursuance of the powers conferred by section 139 of the *Labour and Industry Act 1958*, I, the Governor of the State of Victoria by and with the advice of the the Executive Council thereof do by this my Proclamation amend the Seventh Schedule to the said Act by adding thereto the following class or kind of factory or shop or warehouse, namely:

petrol shops and associated motor garages.

Given under my Hand and the Seal of the State of Victoria aforesaid, at Melbourne, this sixteenth day of April in the year of our Lord One thousand nine hundred and eighty-six and in the thirty-fifth year of the reign of Her Majesty Queen Elizabeth the Second, Queen of Australia.

(L.S.) J. DAVIS McCAUGHEY

By His Excellency's Command

R. C. FORDHAM

Minister for Industry, Technology and Resources

GOD SAVE THE QUEEN!

ACTS OF PARLIAMENT

PROCLAMATION

By His Excellency the Governor of the State of Victoria and its Dependencies in the Commonwealth of Australia, &c., &c., &c.

I, The Governor of the State of Victoria, in the Commonwealth of Australia, do hereby declare that I have this day assented, in Her Majesty's name, to the Bills passed by the Parliament of the said State, the titles whereof are hereunder set forth, together with the short titles, that is to say:

No. 13/1986 *Education (Miscellaneous Matters) Act 1986*.

No. 14/1986 *State Bank (Amendment) Act 1986*.

No. 15/1986 *Zoological Parks and Gardens (Amendment) Act 1986*.

Given under my Hand and the Seal of the State of Victoria aforesaid, at Melbourne, this sixteenth day of April in the year of our Lord One thousand nine hundred and eighty-six and in the thirty-fifth year of the reign of Her Majesty Queen Elizabeth the Second, Queen of Australia.

(L.S.) J. DAVIS McCAUGHEY

By His Excellency's Command

JOHN CAIN
Premier

GOD SAVE THE QUEEN!

No. 13/1986 (1) Section 33 comes into operation on the day on which this Act receives the Royal Assent.

(2) Section 20 comes into operation on the same day as section 10 (9) of the *Teaching Service Act 1983*.

(3) Subject to sub-sections (1) and (2) this Act comes into operation on a day or days to be proclaimed.

No. 14/1986 This Act comes into operation on the day on which it receives the Royal Assent.

No. 15/1986 This Act comes into operation on the day on which it receives the Royal Assent.

GOVERNMENT NOTICES

CONTRACTS ACCEPTED—(Series 1986-87) PUBLIC WORKS

Bulla Shire—Erection of new school, Goonawarra Primary School, \$2 381 870.00—Galvin Construction Group Pty. Ltd, Box Hill.

Keilor City—Internal repairs and painting, Parklands Primary School, \$76 507.00—S. & A. Building Contractors, Glenroy.

D. J. LITTLE

Director-General of Public Works

Public Works Department
Melbourne, 15 April 1986

Private Agents Act 1966

NOTICE OF RECEIPT OF APPLICATIONS FOR LICENCES UNDER THE PROVISIONS OF THE PRIVATE AGENTS ACT 1966

The Clerk(s) of the Magistrates' Court(s) as listed hereunder hereby give notice that applications, as under, have been lodged for hearing by the said Court(s) on the date(s) specified.

Any person desiring to object to any of such applications must—

- (a) lodge with the respective Clerk of the Magistrates' Court a notice in the prescribed form of his objection and of the grounds thereof;
- (b) cause a copy of such notice to be served personally or by post upon the applicant at least three days before the hearing of the application; and
- (c) send or deliver—
 - (i) where the objection is not made by the officer in charge of the police district in which the Court is situated—a copy of the notice to such officer; and
 - (ii) where the objection is not made by the Registrar or Deputy Registrar—a copy to the Registrar.

Full Name of Applicant*	Place of Abode of Applicant or Nominee	Name of Firm or Corporation	Address for Registration	Type of Licence	Date of Hearing
-------------------------	--	-----------------------------	--------------------------	-----------------	-----------------

MAGISTRATES' COURT, KORUMBURRA

Hulls, Ian Robert	Hulls Rd, Leongatha		340 Abbotsford St, North Melbourne	Watchman	8.5.86
-------------------	------------------------	--	--	----------	--------

Dated at Korumburra, 15 April 1986
J. McSWEENEY, Clerk of the Magistrates' Court

MAGISTRATES' COURT, PRAHRAN

Westland, Alfred John	16 Folkstone Cres, Springvale		390 St. Kilda Rd, Melbourne	Watchman	9.5.86
Yeoman, Craig Andrew	6 Elizabeth Crt, Ringwood East		"	"	"
Dower, Warren	4 Pludford St, Sunshine		"	"	"
Jacovou, Peter	89 Truganini Rd, Carnegie		"	"	"
Matuska, Peter George	19 Waters Ave, Altona		"	"	"
McGrath, Ian John	77 McDonalds Rd, Epping		"	"	"
Beilby, George	35 Crossby Cres, Colloroo		"	"	"
Kirk, Richard Donald	9 Morcom Ave, Ringwood		"	"	"
Boyle, Michael	15 Lawrence Crt, The Patch		"	"	"
Page, Leslie George	1/97 Barkly St, St. Kilda		1/97 Barkly St, St. Kilda	Process Server	"
Cook, Hamish Edward	18 Robinson Rd, Hawthorn		18 Robinson Rd, Hawthorn	"	"
Rundle, Philip Leslie	118 Harley St, Nth Knoxfield		390 St. Kilda Rd, Melbourne	Watchman	"

Dated at Prahran, 14 April 1986
R. J. McHUGH, Clerk of the Magistrates' Court

*Or in the case of a firm or corporation, of the Nominee

PRIVATE AGENTS—continued

Full Name of Applicant*	Place of Abode of Applicant or Nominee	Name of Firm or Corporation	Address for Registration	Type of Licence	Date of Hearing
MAGISTRATES' COURT, WILLIAMSTOWN					
Gough, Peter Richard	19 Civic Pde, Altona		19 Civic Pde, Altona	Inquiry Agent	15.5.86
Dated at Williamstown, 16 April 1986 Clerk of the Magistrates' Court					
MAGISTRATES' COURT, CHELTENHAM					
Folkes, Kevin	Unit 1/99 Scotsburn Ave, Oakleigh South	T.S.M. Security	11 Hoffman St, Cheltenham	Watchman	14.5.86
Dated at Cheltenham, 14 April 1986 W. WARD, Clerk of the Magistrates' Court					
MAGISTRATES' COURT, OAKLEIGH					
Smith, Ross Edward	Lot 128 Birdwood Ave, Cockatoo		1388 Dandenong Rd, Oakleigh	Watchman	9.5.86
Molnar, Josef	1/134 Thames St, Box Hill North		96 Murrumbena Rd, Murrumbena	Watchman	16.5.86
Dated at Oakleigh, 11 April 1986 S. WEBSTER, Clerk of the Magistrates' Court					
MAGISTRATES' COURT, BALLARAT					
Alcock, Damien John	Main St, Linton		Main St, Linton	Process Server	1.5.86
Dated at Ballarat, 9 April 1986 A. F. PIETERS, Clerk of the Magistrates' Court					
MAGISTRATES' COURT, FRANKSTON					
Chandler, David John	12 Villawood Dve, Hastings		Statesman Security Services and Consultants P/L., 6 Telopea Crt, North Frankston	Watchman	12.5.86
Dated at Frankston, 11 April 1986 J. T. FERGUSON, Clerk of the Magistrates' Court					
MAGISTRATES' COURT, GEELONG					
Milne, Robert Raymond Turnbull, Barbara Francis	2 Walpole Ave, Belmont 110 Alderbaran Rd, Ocean Grove		2 Walpole Ave, Belmont 110 Alderbaran Rd, Ocean Grove	Guard Agent " "	12.5.86
Dated at Geelong, 14 April 1986 T. NIHILL, Clerk of the Magistrates' Court					

*Or in the case of a firm or corporation, of the Nominee

PRIVATE AGENTS—continued

Full Name of Applicant*	Place of Abode of Applicant or Nominee	Name of Firm or Corporation	Address for Registration	Type of Licence	Date of Hearing
MAGISTRATES' COURT, OAKLEIGH					
Sim, Siong Hee	627 Springvale Rd, Vermont South	Kent Security Services	96 Murrumbeena Rd, Murrumbeena	Watchman	6.5.86
Dated at Oakleigh, 7 April 1986 W. BYRNE, Clerk of the Magistrates' Court					
MAGISTRATES' COURT, MORWELL					
Bolding, John	6 Willaroo Crt, Traralgon		Driffield Rd, Morwell	Watchman	8.5.86
Dated at Morwell, 8 April 1986 K. McMAHON, Clerk of the Magistrates' Court					
MAGISTRATES' COURT, BROADMEADOWS					
Russo, Angelo	5 Heathcote St, Pascoe Vale	Fortified Security and Investigation Services	5 Heathcote St, Pascoe Vale	Inquiry Agent	28.4.86
" "	" "	" "	" "	Inquiry Agent (Firm)	"
" "	" "	" "	" "	Guard Agent (Firm)	"
" "	" "	" "	" "	Guard Agent	"
Sansotta, Domenico	8 Marama St, Merlynston		" "	Inquiry Agent	"
" "	" "		" "	Guard Agent	"
Johnson, Robert Neil	3 Gainford Crt, Greenvale		5 Lily St, Nth Coburg	Watchman	30.4.86
Dated at Broadmeadows, 4 April 1986 F. MORTIMER, Clerk of the Magistrates' Court					
MAGISTRATES' COURT, KORUMBURRA					
Jackson, Richard Bruce	36 Bent St, Leongatha		Leongatha Rd, Allambee	Watchman	1.5.86
Dated at Korumburra, 8 April 1986 J. McSWEENEY, Clerk of the Magistrates' Court					
MAGISTRATES' COURT, PORT MELBOURNE					
Mauger, Paul Andrew	26 Oxford St, Oakleigh	Armaguard	390 St. Kilda Rd, Melbourne	Watchman	1.5.86
Dated at Port Melbourne, 10 April 1986 K. L. HUSSEY, Clerk of the Magistrates' Court					

*Or in the case of a firm or corporation, of the Nominee

PRIVATE AGENTS—continued

Full Name of Applicant*	Place of Abode of Applicant or Nominee	Name of Firm or Corporation	Address for Registration	Type of Licence	Date of Hearing
MAGISTRATES' COURT, WODONGA					
Chester, Edward Eric	20 Moonya Dve, Wodonga		390 St Kilda Rd, Melbourne	Watchman	6.5.86
Dated at Wodonga, 15 April 1986 P. G. DODGSON, Clerk of the Magistrates' Court					
MAGISTRATES' COURT, BACCHUS MARSH					
Jones, Paul Howard	271 Main St, Bacchus Marsh		271 Main St, Bacchus Marsh	Guard Agent (Individual)	16.5.86
Dated at Bacchus Marsh, 18 April 1986 A. R. McGIRR, Clerk of the Magistrates' Court					
MAGISTRATES' COURT, GEELONG					
Harris, Steven Robert	5 Vostok Crt, Whittington	Steven Robert Harris	5 Vostok Crt, Whittington	Guard Agent	2.5.86
Dated at Geelong, 4 April 1986 A. DUNLOP, Clerk of the Magistrates' Court					
MAGISTRATES' COURT, BALLARAT					
Hughes, Gregory Francis Clyde	113 Humffray St, South Ballarat	Security Services (Aust.) Pty. Ltd.	Abel St, Bendigo	Watchman	6.5.86
Dated at Ballarat, 14 April 1986 D. L. CROFT, Clerk of the Magistrates' Court					
MAGISTRATES' COURT, GEELONG					
Shoosmith, Anthony William	14 Godfrey St, East Geelong		1 Ann St, Geelong West	Watchman	6.5.86
Dated at Geelong, 10 April 1986 A. DUNLOP, Clerk of the Magistrates' Court					
MAGISTRATES' COURT, PRESTON					
Avent, Anthony David Peter	49 Cumberland Cres, Thomastown		49 Cumberland Cres, Thomastown	Guard Agent Firm	
Dated at Preston, 10 April 1986 D. HALPIN, Clerk of the Magistrates' Court					
MAGISTRATES' COURT, OAKLEIGH					
Wong, Guan Hua	Farrer Hall, Monash University, Clayton		96 Murrumbeena Rd, Murrumbeena	Watchman	9.5.86
Dated at Oakleigh, 10 April 1986 S. WEBSTER, Clerk of the Magistrates' Court					

*Or in the case of a firm or corporation, of the Nominee

PRIVATE AGENTS—*continued*

<i>Full Name of Applicant*</i>	<i>Place of Abode of Applicant or Nominee</i>	<i>Name of Firm or Corporation</i>	<i>Address for Registration</i>	<i>Type of Licence</i>	<i>Date of Hearing</i>
MAGISTRATES' COURT, NORTHCOTE					
Hickingbotham, Keith David	6 Glandfield St, Northcote			Process Server Guard Agent Inquiry Agent	5.5.86
Dated at Northcote, 10 April 1986 R. J. MALONEY, Clerk of the Magistrates' Court					
MAGISTRATES' COURT, SPRINGVALE					
Shaddock, Lee David	4 Bunarong Close, Keilor		41 Fairview St, Springvale	Watchman	7.5.86
Dated at Springvale, 8 April 1986 B. LAWRENCE, Clerk of the Magistrates' Court					
MAGISTRATES' COURT, EUROA					
Beckenham, Gary David	4/25 Hart St, Euroa		Old Hume Hwy, Euroa	Watchman	8.5.86
Dated at Euroa, 10 April 1986 M. SMART, Clerk of the Magistrates' Court					
MAGISTRATES' COURT, MORNINGTON					
Gardner, Anthony James	3 Tolhurst Pl, Mt Martha		3 Tolhurst Pl, Mt Martha	Process Server Individual	22.5.86
Dated at Mornington, 10 April 1986 M. T. LEA, Clerk of the Magistrates' Court					
MAGISTRATES' COURT, OAKLEIGH					
Livingston, James Hamilton	5 Douglas St, East Malvern	Kent Security Services	96 Murrumbeena Rd, Murrumbeena	Watchman	9.5.86
Dated at Oakleigh, 11 April 1986 W. BYRNE, Clerk of the Magistrates' Court					
MAGISTRATES' COURT, MELBOURNE					
Peart, Phillip Richard	8 Noone St, Clifton Hill		170 Abbotsford St, Nith Melbourne	Inquiry Agent Individual	23.4.86
Dassy, Theophier Mathicoe	9/80 Queens Rd, Melbourne		9/80 Queens Rd, Melbourne	"	"
Dated at Melbourne, 11 April 1986 B. O'TOOLE, Clerk of the Magistrates' Court					
MAGISTRATES' COURT, KYABRAM					
Di Bella, Peter Marco	51 Dawes Rd, Kyabram		51 Dawes Rd, Kyabram	Guard Agent	3.5.1986
Dated at Kyabram, 17 April 1986 S. CORLETT, Clerk of the Magistrates' Court					

*Or in the case of a firm or corporation, of the Nominee

Police Regulation Act 1958

POLICE RECRUITS

Determination No. 1 of the Police Service Board

The Police Service Board, pursuant to the powers conferred on it under section 69 (2) (c) of the *Police Regulation Act 1958*, hereby makes the following Determination with respect to Police Recruits.

DEFINITIONS AND APPLICATION

1. In this Determination, unless inconsistent with the context or subject matter:

“Recruit” means any person (male or female) appointed by the Chief Commissioner pursuant to section 8A of the *Police Regulation Act 1958*.

“Spouse” shall be deemed and taken to include the partner of a de facto marriage, proof of which is to be established on the provision of reasonable evidence, such as a statutory declaration, that the member and de facto partner are normally accommodated as a family unit.

“Substantially dependent spouse” means a spouse whose total income, including income in addition to salary and wages, is less than the adult minimum wage rate for Victoria as decided from time to time by the Australian Conciliation and Arbitration Commission.

“Substantially dependent child” means a child under the age of 16 years, or a student under the age of 21 years if attending full-time at a school, college or university.

“Working Fortnight” means a fortnight in respect of which the recruits’ salaries are paid.

2. Where the context requires, words importing the masculine gender shall be deemed and taken to include the feminine, and the singular to include the plural, and the plural the singular.

3. SALARY AND COMMUTED PENALTY LOADING

	<i>Salary</i>	<i>Commuted Penalty (Weekends Public Holidays Shift Work)</i>
	\$ p.a.	\$ p.a.
Recruit	13 599	2172

ALLOWANCES, PENALTY PAYMENTS AND OTHER SPECIAL RATES

Uniform Maintenance Allowance

4. A recruit who is provided by the Chief Commissioner with a uniform shall be paid the following maintenance allowance by way of reimbursement: \$84 per annum.

Hours of Duty

5. A recruit shall perform the duties allocated to him during 8 hours of each day of the week of which 0-352 of an hour shall be accrued to be taken as time off in days to a maximum of 10 days per year. For the purposes of this paragraph duty performed shall not include recreation leave nor leave without pay.

Provided that for the period 1 July 1986 to 2 January 1988 inclusive, 0-37 of an hour per day of duty shall be accrued to be taken as days off.

6. The Chief Commissioner shall grant to each recruit 4 days off duty in every working fortnight at least one of which days shall be a Sunday. The recruit shall work an average of 80 hours per fortnight.

Performance of Shift Work and Duty Performed on Saturday, Sunday or a Public Holiday

7. The commuted penalty payment is for duty performed by the recruit in the following categories:

- (a) *Afternoon Shift*: Consisting of any shift commencing at or after 1.00 p.m. and before 4.00 p.m.
- (b) *Twilight Shift*: Consisting of any shift commencing between 4.00 p.m. and 7.00 p.m. inclusive.
- (c) *Saturdays, Sundays and Public Holidays*: Consisting of any duty performed
 - (i) between midnight on Friday and midnight on Saturday;
 - (ii) between midnight on Saturday and midnight on Sunday; and
 - (iii) on the holidays prescribed from time to time by S. 71 of the *Public Service Act 1974* or on any holiday proclaimed by the Governor in Council as a Public Holiday for the whole of Victoria and published in the *Government Gazette*.

Overtime

8. Payment for duty which exceeds 80 hours in any working fortnight shall be calculated on a fortnightly basis at an hourly rate based on the recruit's fortnightly salary according to the appropriate formula:

- (i) when a recruit performs duty in excess of 80 hours but not in excess of 83 hours—

$$\frac{\text{Fortnightly salary}}{80} \times 1.5 \times \text{excess hours}$$

- (ii) when a recruit performs duty in excess of 83 hours, for the period in excess of 83 hours—

$$\frac{\text{Fortnightly salary}}{80} \times 2 \times \text{excess hours}$$

Recreation Leave

9. A recruit shall be entitled to recreation leave for a period of 23½ hours for each completed month of employment.

Sick Leave

10. Subject to the production of a satisfactory medical certificate or with the concurrence of the Police Medical Officer leave of absence due to illness may be granted. The basis for determining the amount which may be granted when sick leave with pay is approved shall be ascertained by crediting the recruit with the following period, such sick leave to be cumulative:

on admission to recruit training 15 days leave on full pay

Special Leave

11. The Chief Commissioner may, for reasons not elsewhere provided, grant a recruit leave with pay up to a maximum of 5 working days during his employment as a recruit.

Meals and Accommodation

12. A recruit shall be provided with meals and accommodation free of charge.

Dependents

13. A recruit who maintains his substantially dependent spouse and/or substantially dependent children and is required to live at the Police Academy shall be entitled to receive an allowance of \$53.50 per week.

14. This Determination shall come into operation on and from 13 April 1986.

Dated 7 April 1986.

T. B. SHILLITO
A Judge of the County Court of Victoria, Chairman and Member of the Police
Service Board

G. DAVIDSON
Member of the Police Service Board

F. J. LESLIE
Member of the Police Service Board

Police Regulation Act 1958
VICTORIA POLICE FORCE

Determination No. 448 of the Police Service Board

The Police Service Board, in pursuance of the powers in that behalf conferred by the *Police Regulation Act 1958*, hereby makes the following Determination (that is to say):

1. The Determination No. 179 of the Police Service Board of 14 December 1971, and published in the *Government Gazette* of 25 January 1972, as amended, is hereby further amended as follows:

1.1 In paragraph 62 (1) by inserting the following proviso:

“Provided that any member who has been required by the Ministry of Housing to vacate its residence shall be covered by the provisions of this sub-paragraph and other sub-paragraphs of this paragraph as if such member was a member transferred from one station or district to another station or district and provided further that a member who receives expenses or reimbursement under this proviso shall not be deemed to have been paid ‘transfer expenses’ for the purposes of paragraph 62 (2).”

2. This Determination shall come into operation on and from 13 April 1986.

Dated 7 April 1986

T. B. SHILLITO
A Judge of the County Court of Victoria, Chairman and
Member of the Police Service Board

G. DAVIDSON
Member of the Police Service Board

F. J. LESLIE
Member of the Police Service Board

Police Regulation Act 1958
VICTORIA POLICE FORCE

Determination No. 449 of the Police Service Board

The Police Service Board, in pursuance of the powers in that behalf conferred by the *Police Regulation Act 1958*, hereby makes the following Determination (that is to say):

1. The Determination No. 179 of the Police Service Board of 14 December 1971, and published in the *Government Gazette* of 25 January 1972, as amended, is hereby further amended as follows:

1.1 In paragraph 63 (1) by inserting the following proviso:

“Provided that on his appointment as a member of the Force during which he receives an allowance as described in this paragraph while subject to the Police Recruit Determination No. 1.”

1.2 In paragraph 72 by inserting the following proviso:

“Provided further that time accrued but not taken by a member while subject to the Police Recruit Determination No. 1 shall be credited to him on his appointment as a member of the Force.”

1.3 In paragraph 83 by inserting the following proviso:

“Provided that for the purpose of determining ‘number of days of service’ the days of service of a member while subject to the Police Recruit Determination No. 1 for which recreation leave has not been taken, shall be credited to him on his appointment as a member of the Force.”

1.4 In paragraph 87 (1) by inserting the following proviso:

“Provided that on his appointment as a member of the Force—

(a) that the said period of 2 years shall include any period of his service as a recruit.

(b) that the member's entitlement to any such leave shall be reduced by any period of such leave granted to him while serving as a recruit."

1.5 By deleting sub-paragraph 117A (5) and substituting therefor the following new sub-paragraph:

"(5) The entitlement of a female member to leave under paragraphs 117A (1) or 117A (3) shall be subject to the completion by her of 12 months' continuous service including service while subject to the Police Recruit Determination No. 1 prior to the date on which she would otherwise be required or entitled to take such leave."

2. This Determination shall come into operation on and from 13 April 1986.

Dated 7 April 1986

T. B. SHILLITO
A Judge of the County Court of Victoria, Chairman and
Member of the Police Service Board

G. DAVIDSON
Member of the Police Service Board

F. J. LESLIE
Member of the Police Service Board

Police Regulation Act 1958

RETIRED POLICE RESERVE OF VICTORIA

Determination No. 5 of the Police Service Board

The Police Service Board, pursuant to the powers conferred on it under section 69 (2) (aa) of the *Police Regulation Act 1958*, hereby makes the following determination with respect to members of the "Retired Police Reserve of Victoria" (that is to say):

1. The Determination No. 1 of the Police Service Board, and published in the *Government Gazette* of 7 March 1984, is hereby amended as follows:

1.1 By deleting Division IV—Special Duties Allowances and substituting therefor the following new Division IV:

"DIVISION IV—SPECIAL DUTIES ALLOWANCES

The nominated Police Reservist shall whilst holding the appointment and performing the function, be paid the allowance as specified:

Reservist: WEBSTER, F. C.
Appointment: Bendigo
Function: Radio Operator
Allowance: As prescribed in the Fifth Schedule to Determination 179.
Reservist: SEWELL, C. A.
Appointment: Wangaratta
Function: Radio Operator
Allowance: As prescribed in the Fifth Schedule to Determination 179.
Reservist: SHARAM, L. R.
Appointment: Police Band
Function: Bandsman
Allowance: As prescribed in paragraph 8 (c) (iii) (A) and (B) of Determination No. 179 of the Police Service Board."

2. This Determination shall come into operation on and from 7 April 1986.
Dated 7 April 1986

T. B. SHILLITO
A Judge of the County Court of Victoria, Chairman and
Member of the Police Service Board

G. DAVIDSON
Member of the Police Service Board

F. J. LESLIE
Member of the Police Service Board

REWARD — \$500 000

The co-operation of the general public is sought with a view to establishing the identity of the person or persons responsible for the bombing which occurred on 27 March 1986 outside the Victoria Police Complex in Russell Street, Melbourne.

A reward of \$500 000 (five hundred thousand dollars) will be paid at the discretion of the Chief Commissioner of Police, by the Government of Victoria, for information leading to the apprehension and conviction of the person or persons responsible for this bombing.

Any information, which will be treated as confidential, may be given at any time of the day or night, to the Officer in Charge, Criminal Investigation Branch, Russell Street, Melbourne. (Telephone 667 1911) or the Officer in Charge of any Police Station.

C. R. T. MATHEWS
Minister for Police and Emergency Services

Ministry for Police and Emergency Services
Melbourne, 16 April 1986

**MAGISTRATES' COURTS (FOURTH
SCHEDULE AMENDMENT) RULES 1986**

The Attorney-General seeks to make the above Rules and invites public comment upon them.

The proposed Rules are to establish the level of costs that may be charged under Part VIIA of the *Magistrates (Summary Proceedings) Act 1975* (the new PERIN legislation)—

- (a) by an enforcement agency on the issue of a courtesy letter (\$8.00) and the issue of a certificate for enforcement (\$10.00); and
- (b) on the execution of a warrant (\$10.00).

A Regulatory Impact Statement has been prepared in accordance with the provisions of the *Subordinate Legislation Act 1962*. Copies of the statement may be obtained from the Courts Administration Division of the Law Department. (See below for address.)

Public comment and submissions should be made to the Courts Administration Division, Law Department, 471 Little Bourke Street, Melbourne, 3000, within 21 days of the date of publication of this notice.

JOHN B. KING
Secretary to the Law Department

Police Regulation Act, Section 122

SALE OF UNCLAIMED MOTOR VEHICLE

An owner is required for a purple 1974 model Ford Sedan previous Registration No. ALP 667, engine No. JG34PJ92388C.

The vehicle came into possession of Police on 16 September 1985 and if not claimed, will be sold by public auction at the Flemington Police Station, 34 Wellington Street, Flemington, on Thursday, 29 May 1986, at 10.30 a.m.

S. I. MILLER
Chief Commissioner

Police Regulation Act, Section 122

SALE OF UNCLAIMED MOTOR VEHICLE

An owner is required for an unregistered green Valiant Station Wagon, Engine No. J4F 0313.

The vehicle came into the possession of Police on 23 August 1985 and if not claimed, will be sold by public auction at the Heidelberg Police Station, Jika Street, Heidelberg, on Wednesday, 21 May 1986 at 10.00 a.m.

S. I. MILLER
Chief Commissioner of Police

Transport Act 1983

NOTICE DECLARING THE WIDENINGS OF EXISTING ROADS TO BE FIT TO BE USED AS PUBLIC HIGHWAYS

The Road Construction Authority is of the opinion that the widenings of the existing roads as set out below are fit to be used as public highways—

The widenings of an existing road in the Shire of Buninyong as shown hatched on plan numbered GP 16386A hereunder.

The widenings of an existing road in the Shire of Stawell as shown hatched on plans numbered GP 15516C, GP 15516E, GP 15517A, GP 15518A and GP 15519A hereunder.

The widening of an existing road in the Shire of Rosedale as shown hatched on plan numbered GP 16541A hereunder.

The widening of an existing road in the Shire of Heytesbury as shown hatched on plan numbered GP 16604A hereunder.

The widening of an existing road in the Shire of Warrnambool as shown hatched on plan numbered GP 16579A hereunder.

The widening of an existing road in the Township of Stawell as shown hatched on plan numbered GP 16294A hereunder.

In accordance with the provisions of clause 2 (2), Schedule 5 of the Transport Act 1983, the widenings shall, upon the publication of this notice in the Government Gazette, become and be absolutely dedicated to the public as public highways within the meaning of any law now or hereafter in force.

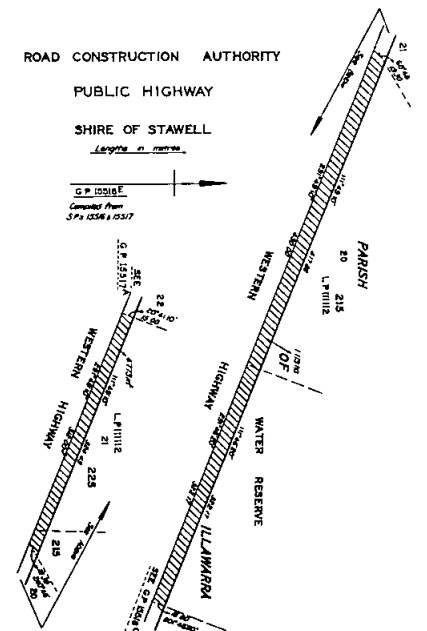
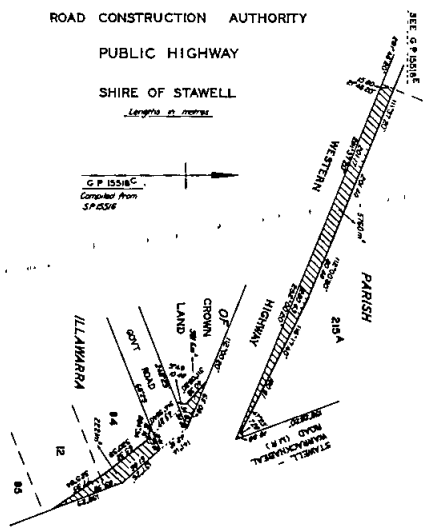
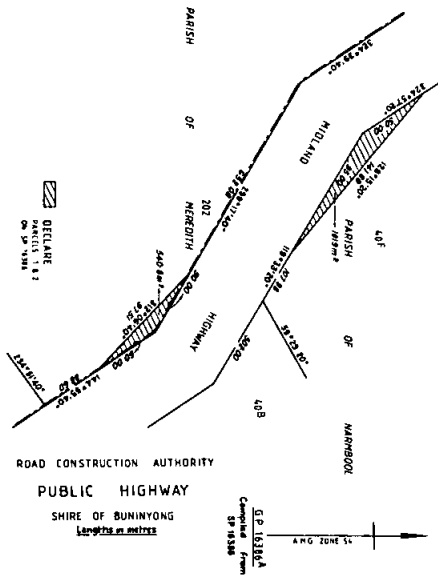

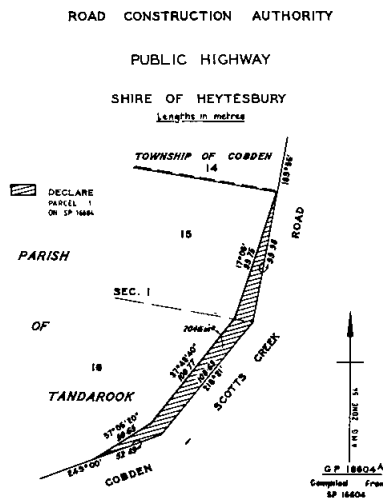
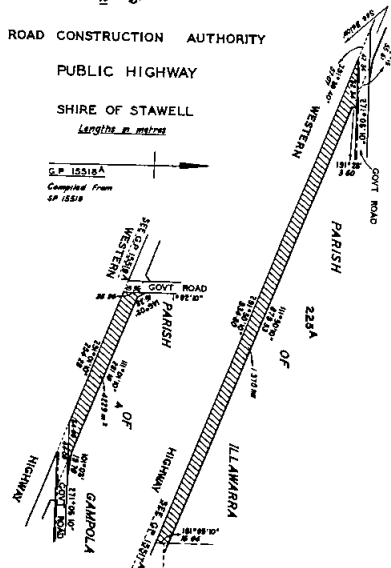
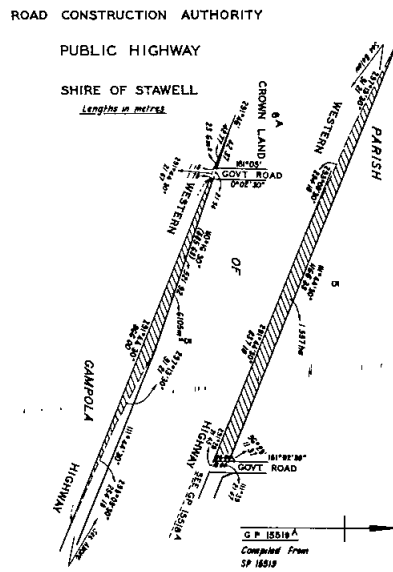
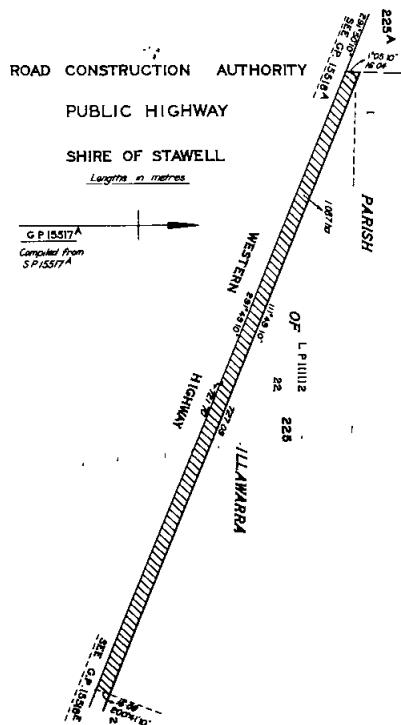

ROAD CONSTRUCTION AUTHORITY

PUBLIC HIGHWAY

SHIRE OF WARRNAMBOOL

Lengths in metres

PARISH OF YARPTURK

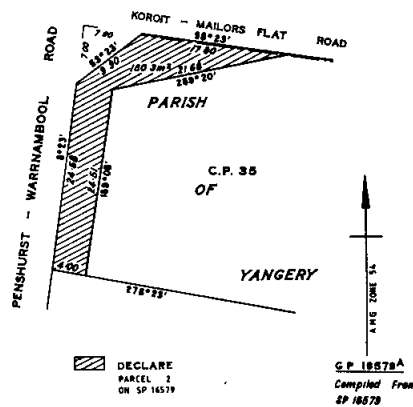

ROAD CONSTRUCTION AUTHORITY

PUBLIC HIGHWAY

TOWN OF STAWELL

Lengths in metres

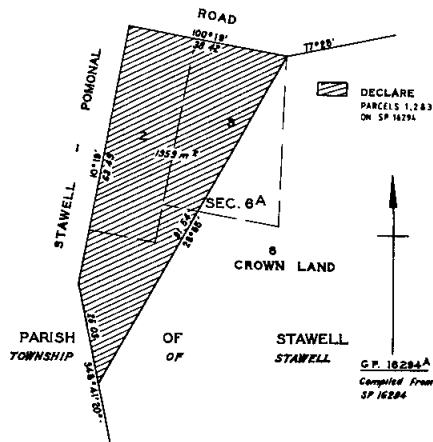

16 April 1986

T. H. RUSSELL
Chairman and Managing Director

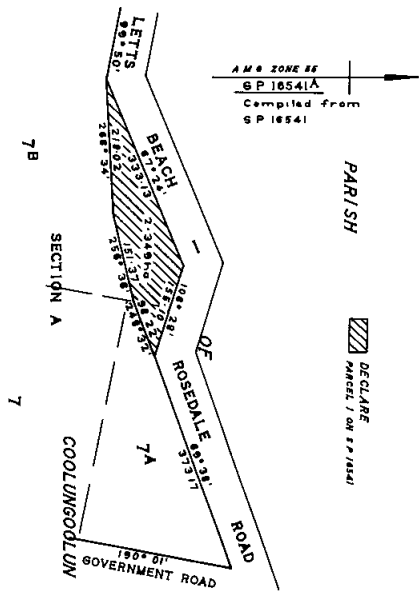

ROAD CONSTRUCTION AUTHORITY

PUBLIC HIGHWAY

SHIRE OF ROSEDALE

Lengths in metres

Town and Country Planning Act 1961
MELBOURNE METROPOLITAN PLANNING
SCHEME

Revocation No. 45B
Notice of Revocation

Notice of Order under section 32 (5)

In pursuance of the powers conferred by the *Town and Country Planning Act 1961*, the Governor in Council on 16 April 1986, revoked in part the abovementioned scheme in respect of land at the western end of Western Avenue, adjacent to the Moonee Ponds Creek, comprised in Certificate of Title Volume 8875, Folio 055 and made an Order pursuant to section 32 (5).

The Order provides that the land so revoked may be used and developed only as if—

- (a) it were land to which the Melbourne Metropolitan Planning Scheme applies;
- (b) it were land partly within the Conservation A Zone, partly within the Special Extractive A Zone and partly reserved for Proposed Public Purposes 18—to the same extent and manner as it was so zoned and reserved as at 2 October 1984; and
- (c) notwithstanding any provisions of the Melbourne Metropolitan Planning Scheme, the land may, subject to the grant of a permit by the Responsible Authority and any conditions included in the permit, be used and developed for one or more of the purposes of a Major Sports Ground used for the sport of motor cycle racing and training, Motor Vehicle Racing Track for use by motor cycles, a mini-motor cycle track and a motor cycle riding and training park.

A copy of the Orders relating to the revocation may be inspected during office hours at the office of the Ministry for Planning and Environment, The Olderfleet Buildings, 477 Collins Street, Melbourne.

DAVID YENCKEN
Secretary for Planning and Environment

Town and Country Planning Act 1961
MELBOURNE METROPOLITAN PLANNING
SCHEME

Amendment No. 289 Part B
Notice of Amendment

In pursuance of the powers conferred by the *Town and Country Planning Act 1961*, the Governor in Council on 16 April 1986, amended the abovementioned scheme in respect of the municipal district of the City of Preston, and for which the Minister for Planning and Environment is the Responsible Authority.

The amendment comes into operation on the date this Notice is published in the *Government Gazette*.

The amendment includes the rezoning of the Education Department site in Amery Street, Reservoir, to Residential C.

A copy of the documents may be inspected free of charge, during office hours, at the office of the Ministry for Planning and Environment, The Olderfleet Buildings, 477 Collins Street, Melbourne.

DAVID YENCKEN
Secretary for Planning and Environment

Town and Country Planning Act 1961
MELBOURNE METROPOLITAN PLANNING
SCHEME

Amendment No. 166 Part 1
Notice of Approval

In pursuance of the powers conferred by the *Town and Country Planning Act 1961*, the Governor in Council on 16 April 1986, approved the abovementioned scheme in respect of the municipal district of the City of Heidelberg and for which the Minister for Planning and Environment is the Responsible Authority.

The scheme comes into operation on the date this Notice is published in the *Government Gazette*.

The scheme includes the rezoning of land on the north west side of Studley Road, to the east of Waldemar Road, to Residential C.

A copy of the documents may be inspected free of charge, during office hours, at the Office of the Ministry for Planning and Environment, The Olderfleet Buildings, 477 Collins Street, Melbourne.

DAVID YENCKEN
Secretary for Planning and Environment

Town and Country Planning Act 1961
CITY OF CROYDON PLANNING SCHEME
Amendment No. 141
Notice of Approval

In pursuance of the powers conferred by the *Town and Country Planning Act 1961*, the Governor in Council on 16 April 1986, approved the abovementioned scheme in respect of the municipal district of the City of Croydon and for which the Council of the City of Croydon is the Responsible Authority.

The scheme comes into operation on the date this Notice is published in the *Government Gazette*.

The scheme includes ordinance provisions and a rezoning to a Special Use "A"—"7" zone to facilitate the establishment of a retired persons residential community at 67-79 Maroondah Highway, Croydon.

A copy of the documents may be inspected free of charge, during office hours at the Office of the Ministry for Planning and Environment, Olderfleet Buildings, 477 Collins Street, Melbourne and at the Office of the Responsible Authority being the City of Croydon, Civic Square, Croydon.

DAVID YENCKEN
Secretary for Planning and Environment

Town and Country Planning Act 1961
SHIRE OF BULLA PLANNING SCHEME
Amendment No. 56
Notice of Approval

In pursuance of the powers conferred by the *Town and Country Planning Act 1961*, the Governor in Council on 16 April 1986, approved the abovementioned scheme in respect of the municipal district of the Shire of Bulla and for which the Bulla Shire Council is the Responsible Authority.

The scheme comes into operation on the date this Notice is published in the *Government Gazette*.

The scheme includes the rezoning of Lot 4, LP 23111, Brook Street, Sunbury, from Residential to Commercial.

A copy of the documents may be inspected free of charge, during office hours, at the office of the Ministry for Planning and Environment, The Olderfleet Buildings, 477 Collins Street, Melbourne and at the office of the Council of the Shire of Bulla at Sunbury.

DAVID YENCKEN
Secretary for Planning and Environment

Town and Country Planning Act 1961
SHIRE OF HEALESVILLE INTERIM
DEVELOPMENT ORDER 1976

Amendment No. 23
Notice of Amendment

In pursuance of the powers conferred by the *Town and Country Planning Act 1961*, the Governor in Council on 16 April 1986, amended the abovementioned Order in respect of various estates within 4 kilometres of the Healesville town centre varying in size from 0.5 hectares to 150 hectares and for which the Healesville Shire Council is the Responsible Authority.

The amendment comes into operation on the date this Notice is published in the *Government Gazette*.

The amendment introduces new controls in the Ordinance for Special Study Zone including Management Plans to allow development to proceed in old and inappropriate subdivisions subject to permit and special provisions.

A copy of the documents may be inspected free of charge, during office hours, at the office of the Ministry for Planning and Environment, the

Olderfleet Buildings, 477 Collins Street, Melbourne, and at the Office of the Council of the Shire of Healesville.

DAVID YENCKEN
Secretary for Planning and Environment

Town and Country Planning Act 1961
SHIRE OF LILLYDALE PLANNING SCHEME
1958

Amendment No. 174
Notice of Approval

In pursuance of the powers conferred by the *Town and Country Planning Act 1961*, the Governor in Council on 16 April 1986, approved the abovementioned scheme in respect of the municipal district of the Shire of Lillydale and for which the Shire of Lillydale is the Responsible Authority.

The scheme comes into operation on the date this Notice is published in the *Government Gazette*.

The scheme rezones land at part Crown Allotment 4, Section 29, Maroondah Highway, Lillydale from Residential "G" to Special Uses No. 13 (Retirement Village) to permit a Retirement Village development comprising units, special accommodation, nursing home, community centre and recreational facilities.

A copy of the documents may be inspected free of charge, during office hours, at the office of the Ministry for Planning and Environment, Olderfleet Buildings, 477 Collins Street, Melbourne and at the office of the Council of the Shire of Lillydale at Lillydale.

DAVID YENCKEN
Secretary for Planning and Environment

Films Act 1971
EXEMPTION PURSUANT TO SECTION 11 (2)

Whereas:

1. Section 11 (2) of the *Films Act 1971* provides that the Governor in Council may in any particular case by direction in writing under his hand exempt any film from the operation of Part II. of the Act to the extent specified in the direction.

2. It is expedient that the films set out in the Schedule hereto be exempted from the provisions of Part II. of the said Act as would require—

the films to be registered, examined and classified;

the advertising relating to films to display classification or classification symbols;

applications for the registration of films to be accompanied by the prescribed fee:

Subject to the following conditions:

- (i) That the films be exhibited only at the St Kilda Film Festival commencing on 17 April 1986;

- (ii) That the films are screened not more than three times in the course of the festival;
- (iii) That the films are not screened other than before a subscription audience; and
- (iv) That no person under the age of 18 years is admitted to screenings of the films.

Now therefore I, the Governor of the State of Victoria by and with the advice of the Executive Council thereof, in pursuance of the powers conferred by the *Films Act 1971*, do hereby exempt the films set out in the Schedule hereto from the provisions of Part II. of the *Films Act 1971*, subject to the conditions set out in item 2 above:

SCHEDULE

Waterfall
The Man You Know
Queen of the Night
Camera Natura
Fifty Fifty
Museum
Timbercraft (Artisans of Australia)
Raoul Wallenburg (Between the Lines)
Kitchen Sync
Discourse on the Amateur Cinema
223
First Mate
Elephant Theatre
Red Matildas
PJQ 149
La Scala Lo Scalone
7.56 AM
Freely Given
The Cellist
This Life's Body
Chasing Lizards
Even Cowboys
Joshua Cooks
Mongrels Funeral
The Search for the Golden Boomerang
Trevor the Cat
The Fogbrook Thing
The Paper Boy
On Loan
Sunday Lunch
High Heels
Couldn't Be Fairer
The Drover's Wife

Given under my Hand and the Seal of the State of Victoria aforesaid, at Melbourne, this sixteenth day of April in the year of our Lord One thousand nine hundred and eighty-six and in the thirty-fifth year of the reign of Her Majesty Queen Elizabeth the Second, Queen of Australia.

(L.S.) J. DAVIS MCCAUGHEY

By His Excellency's Command

J. H. KENNAN
Attorney-General

GOD SAVE THE QUEEN!

Survey Co-ordination Act 1958

PROPOSALS TO ASSIGN OR ALTER PLACE NAMES

The Place Names Committee gives notice that it intends to assign/alter the following place names:

Place Name	Location
Hayes Reserve	Shire of McIvor, an area of Crown land between sections 273 and 24 Parish of Toobarac
Collins Settlement Historic Site	Shire of Flinders, an area of land controlled by the National Parks Service and the Shire of Flinders between and adjacent to Eastern Sister and Western Sister, Sorrento
Miller Reserve	City of Knox, Mountain Highway, The Basin
Main Ridge Flora Reserve	Shire of Flinders, National Park Service controlled reserve at the intersection of the Mornington-Flinders Road and Barkers Road
Jack Thomas Reserve	City of Berwick, a reserve in Fox Road, Berwick
John Cummins Nature Park	Shire of Yea—proposal to alter the name of the Yea Nature Park on the outskirts of the town on the Yea-Alexandra Road.

Any objections to these proposals must be in writing (stating the grounds of objections) and be lodged with the Place Names Committee within two months of the publication of this notice.

ASSIGNMENT OF PLACE NAMES

Subsequent to the publication of a notice of proposal to assign/alter place names, the following place names are assigned:

Place Name	
Heatherwood School	Altering the name of Mitcham Special School
Victorian Schools Nursery	Altering the name of the Victorian State Schools Nursery
Bates Reserve	Altering the name of a section of Greenwich Reserve, Williamstown
Sir Douglas Nicholls Reserve	Altering the name of the Watt Street Recreation Reserve, Northcote

M. P. CAHILL
Secretary

Place Names Committee
Department of Property and Services
2 Treasury Place
Melbourne 3002

*Cemeteries Act 1958*SCALE OF FEES OF THE BUMBERRAH
PUBLIC CEMETERY

In pursuance of the powers conferred upon them by the Cemeteries Act the trustees of the Bumberrah Public Cemetery hereby make the following scale of fees, which shall come into operation upon publication in the *Government Gazette*, and from and after such publication every scale of fees heretofore made by the said trustees shall be and is hereby rescinded to the extent to which it conflicts with this scale.

<i>Lawn Section</i>	
	\$
Land 2.44 m × 1.22 m	175.00
Interment	100.00
Bronze plaque 380 mm × 280 mm and flower container	145.00
Dual conversion plaque and flower container	175.00
<i>Second Interment</i>	
Detachable plaque	50.00
Interment	100.00
<i>Monumental Section</i>	
Land 2.44 m × 1.22 m	175.00
Interment	100.00

P. K. STEWART, Trustee
R. IRVINE, Trustee
N. S. STEWART, Trustee

Approved by the Governor in Council—16 April 1986—L. G. HOUSTON, Clerk of the Executive Council.

*Cemeteries Act 1958*SCALE OF FEES OF THE MAFFRA PUBLIC
CEMETERY

In pursuance of the powers conferred upon them by the Cemeteries Act the trustees of the Maffra Public Cemetery hereby make the following scale of fees, which shall come into operation upon publication in the *Government Gazette*, and from and after such publication every scale of fees heretofore made by the said trustees shall be and is hereby rescinded to the extent to which it conflicts with this scale.

	\$
Cost of Plaques	100.00
Sinking of Graves	150.00

P. L. SEMMENS, Trustee
P. M. NYE, Trustee
C. SEMMENS, Trustee

Approved by the Governor in Council 16 April 1986—L. G. HOUSTON, Clerk of the Executive Council

*Cemeteries Act 1958*SCALE OF FEES OF THE MADDINGLEY
PUBLIC CEMETERY

In pursuance of the powers conferred upon them by the Cemeteries Act the trustees of the Maddingley Public Cemetery hereby make the following scale of fees, which shall come into operation upon publication in the *Government Gazette*, and from and after such publication every scale of fees heretofore made by the said trustees shall be and is hereby rescinded to the extent to which it conflicts with this scale.

	\$
Lawn Grave	\$425.00
<i>Sinking Charges for Private Graves</i>	
Sinking grave 1.83 m deep	140.00
Reopening grave (no cover)	140.00
Reopening grave (with cover or kerb)	150.00

W. R. SCOTT, Trustee
A. E. CONNE, Trustee
N. S. BOND, Trustee

Approved by the Governor in Council—16 April 1986—L. G. HOUSTON, Clerk of the Executive Council

*Cemeteries Act 1958*SCALE OF FEES OF THE LANDSBOROUGH
PUBLIC CEMETERY

In pursuance of the powers conferred upon them by the Cemeteries Act the trustees of the Landsborough Public Cemetery hereby make the following scale of fees, which shall come into operation upon publication in the *Government Gazette*, and from and after such publication every scale of fees heretofore made by the said trustees shall be and is hereby rescinded to the extent to which it conflicts with this scale.

	\$
Land, 2.44 m × 1.22 m	75.00
Sinking grave 1.83 m deep	110.00
Interment fee	35.00
Reopening grave (no cover)	110.00
Reopening grave (with cover)	120.00
Permission to erect a headstone or monument—5 per cent of cost with a minimum of \$15.00	
Exhumation Charge (when authorized)	300.00

C. J. DEAN, Trustee
B. B. BROWNE, Trustee
B. MURPHY, Trustee

Approved by the Governor in Council, 16 April 1986—L. G. HOUSTON, Clerk of the Executive Council

Cemeteries Act 1958

SCALE OF FEES OF THE COBRAM PUBLIC CEMETERY

In pursuance of the powers conferred upon them by the Cemeteries Act the trustees of the Cobram Public Cemetery hereby make the following scale of fees, which shall come into operation upon publication in the *Government Gazette*, and from and after such publication every scale of fees heretofore made by the said trustees shall be and is hereby rescinded to the extent to which it conflicts with this scale.

	\$
Land 2.44 m × 1.22 m	220.00
Interment fee (including cost of monument)	548.00

COUNCILLORS OF THE SHIRE OF COBRAM, Trustees

Approved by the Governor in Council, 16 April 1986—L. G. HOUSTON, Clerk of the Executive Council

Cemeteries Act 1958

SCALE OF FEES OF THE BEECHWORTH PUBLIC CEMETERY

In pursuance of the powers conferred upon them by the Cemeteries Act the trustees of the Beechworth Public Cemetery hereby make the following scale of fees, which shall come into operation upon publication in the *Government Gazette*, and from and after such publication every scale of fees heretofore made by the said trustees shall be and is hereby rescinded to the extent to which it conflicts with this scale.

	\$
Permission to erect a headstone	40.00

B. G. FORREST, Trustee

C. COLLINS, Trustee

J. TOLLEY, Trustee

E. J. HAWKING, Secretary

Approved by the Governor in Council, 16 April 1986—L. G. HOUSTON, Clerk of the Executive Council

Cemeteries Act 1958

SCALE OF FEES OF THE CRIB POINT PUBLIC CEMETERY

In pursuance of the powers conferred upon them by the Cemeteries Act the trustees of the Crib Point Public Cemetery hereby make the following scale of fees, which shall come into operation upon publication in the *Government Gazette*, and from and after such publication every scale of fees heretofore made by the said trustees shall be and is hereby rescinded to the extent to which it conflicts with this scale.

Public Graves

	\$
Interment in grave without exclusive right—stillborn child	15.00
Interment in grave without exclusive right—others	25.00

Private Graves

Land, 2.44 m × 1.22 m	55.00
Land, 2.44 m × 2.44 m	110.00

Sinking Charges for Private Graves

Sinking grave 1.83 m deep	180.00
Each additional 0.3 m	20.00
Sinking oversize grave (extra)	25.00
Cancellation of order to sink (if commenced)	150.00

Reopening Charges

Reopening grave (no cover)	180.00
Reopening grave (with cover)	190.00

Extra Charges

Interment outside hours, or on Sundays, Saturdays or Public Holidays	50.00
Interment in private grave without due notice	40.00

Miscellaneous Charges

Interment fee (including Certificate of right of burial)	35.00
Number peg or brick	5.00
Permission to erect a headstone or monument—5 per cent of cost with minimum cost	10.00
Permission to construct a brick grave surround, stone kerb, tilework or concrete	7.00
Exhuming the remains of a body (when authorized)	250.00
Interment of ashes in a Private Grave	25.00

T. WHISTON, Trustee

H. CROW, Trustee

F. P. MYERS, Trustee

G. WOOLLEY, Trustee

W. SMITH, Trustee

P. DIETZSCH, Trustee

C. KLEINIG, Trustee

Approved by the Governor in Council, 16 April 1986—L. G. HOUSTON, Clerk of the Executive Council

Police Offences Act 1958, No. 6337

DIVISION 1A—STATE CLASSIFICATION OF PUBLICATIONS BOARD

Take note that the State Classification of Publications Board has classified the following publications in accordance with the provisions of section 180H (1) of the *Police Offences Act 1958*.

Each publication shall be subject to the following restrictions:

- (a) It shall not be offered for sale, sold or delivered to any person under the age of 18 years;
- (b) It shall not be made available for inspection or perusal by any person under the age of 18 years;
- (c) It shall not be exhibited or displayed in any place to which persons under the age of 18 years have access or so that it is visible from any such place.

<i>Title</i>	<i>Distributor</i>
A.C.M.—Personal Contacts—No. 37	A.C.M.
High Times—May 1986	Peter McKenzie
Best of Couples, The—June 1986, Vol. 6, No. 6	Gordon & Gotch Ltd.
Best of Velvet Talks! No. 8	Gordon & Gotch Ltd.
Couples Today—July 1986, Vol. 9, No. 4	Gordon & Gotch Ltd.
Honcho—May 1986, Vol. 9, No. 2	Gordon & Gotch Ltd.
Jock—May 1986, Vol. 2, No. 5	Gordon & Gotch Ltd.
Lusty Letters—Summer 1986, Vol. 4, No. 3	Gordon & Gotch Ltd.
New Look of Oui, The—May 1986, Vol. 15, No. 5	Gordon & Gotch Ltd.
Oui Letters—June 1986, Vol. 5, No. 6	Gordon & Gotch Ltd.
Samantha Fox's X-Rated Cinema—June 1986, Vol. 10 No. 4	Gordon & Gotch Ltd.
Swank—June 1986, Vol. 33, No. 6	Gordon & Gotch Ltd.
Vibrations—April 1986	Gordon & Gotch Ltd.

R. V. DOOLEY,
Assistant Secretary,
State Classification of Publications Board

Police Offences Act 1958, No. 6337

DIVISION 1A—STATE CLASSIFICATION OF PUBLICATIONS BOARD

Take note that the State Classification of Publications Board has classified the following publications in accordance with the provisions of section 180H (1) of the *Police Offences Act 1958*.

Each publication shall be subject to the following restrictions:

- (a) It shall not be offered for sale, sold or delivered to any person under the age of 18 years;

(b) It shall not be made available for inspection or perusal by any person under the age of 18 years;

<i>Title</i>	<i>Distributor</i>
Advocate, The—Issue 443, April 1 1986	Overseas Periodicals (Aust.) Pty. Ltd.
Advocate, The—Issue 444, April 15, 1986	Overseas Periodicals (Aust.) Pty. Ltd.
American Survival Guide—May 1986, Vol. 8, No. 5	Gordon & Gotch Ltd.
Fighting Elite—June 1986, Vol. 11, No. 3	Gordon & Gotch Ltd.
Fox—July 1986, Vol. 3, No. 2	Gordon & Gotch Ltd.
Newlook—May 1986, Vol. 2, No. 1	Gordon & Gotch Ltd.
Numbers—June 1986, Vol. 8, No. 3	Gordon & Gotch Ltd.
Penthouse Hot Talk—No. 16	Gordon & Gotch Ltd.
Penthouse Variations—May 1986	Gordon & Gotch Ltd.
Soldier of Fortune—May 1986, Vol. 11, No. 5	Gordon & Gotch Ltd.

R. V. DOOLEY,
Assistant Secretary,
State Classification of Publications Board

I hereby give notice on 8 April 1986 the Public Trustee filed Elections to Administer the following deceased person's estates in accordance with section 17 of the *Public Trustee Act 1958*:

Bromley, Emily, formerly of Flat 2, 6 Tarakan Street (in the will called Trakan Avenue), West Heidelberg, but late of Flat 11, 10 Louisa Street, Croydon, widow, died 20 December 1985.

David, Pushpa, late of Richmond House, 353A Church Street, Richmond, retired secretary, died 3 November 1985.

Goldberg, Ethel, late of Kew, Pensioner, died 2 September 1985.

Morris, Elvie Isabel, formerly of 9 Venice Street, Morningside but late of Vermont Private Nursing Home, 770 Canterbury Road, Vermont, pensioner, died 27 January 1986.

Neill, Thomas Patrick, late of 43 Elphin Street, Ivanhoe, retired engineer, died 13 November 1984.

Potleca, Ermanno also known as Edmundo Potleca late of Flat 1, 371 Drummond Street, Carlton, labourer, died 27 January 1986.

Seddon, John Eric, late of 16 Haydens Road, Beaumaris, pensioner, died 25 January 1986.

I hereby give notice on 9 April 1986 the Public Trustee filed Elections to Administer the following deceased persons' estates in accordance with section 17 of the *Public Trustee Act 1958*:

Allan, Mervyn Lindsay, formerly of 18 Winifred Street, Oakleigh, but late of 15 Mueller Street, Portarlington, retired manager, died 5 February 1986.

Bennett, Kathleen Joyce, late of 31 Finlayson Street, Malvern, home duties, died 3 February 1986.

Bridges, Floris Louise Devereaux, late of Glengollan Village, 9A St Elmo Avenue, Ferntree Gully, home duties, died 20 February 1986.

Brown, Albert Edward, formerly of R.S.L. Park, Overport Road, Frankston, but late of The Mount Eliza Geriatric Centre, Jacksons Road, Mount Eliza, pensioner, died 26 February 1986.

Dess, Arthur Joseph, also known as Dess, Arthur, late of Western Terrace Special Accommodation House, pensioner, died 13 January 1986.

Duff, Esther Vivien Ivey, late of Orrong Lodge, 19 Orrong Crescent, North Caulfield, widow, died 10 February 1986.

Edgar, Olive May, formerly of 213 Mitchell Street, Northcote, but late of Dowell Court Special Accommodation Home, 159 Lower Heidelberg Road, Ivanhoe, home duties, died 20 February 1986.

McIntyre, Emilie Amelia, late of 191 Booran Road, Glenhuntly, home duties, died 13 February 1986.

Moore, Janet Aileen, late of Pleasant Creek Training Centre, Western Highway, Stawell, pensioner, died 25 January 1986.

Thomson, Nellie, formerly of Kyneton, but late of Elgar Private Nursing Home, 366 Elgar Road, Box Hill, pensioner, died 23 October 1985.

Dated 16 April 1986

P. T. SPENCER
Public Trustee

Creditors, next of kin and others having claims against the estate of any of the under-mentioned deceased persons are required to send particulars of their claims to the Public Trustee, 168 Exhibition Street, Melbourne, Vic. 3000, the personal representative, on or before 26 June 1986 after which date the Public Trustee may convey or distribute the assets having regard only to the claims of which the Public Trustee then has notice:

Allan, Mervyn Lindsay, formerly of 18 Winifred Street, Oakleigh, but late of 15 Mueller Street, Portarlington, retired manager, died 5 February 1986.

Bennett, Kathleen Joyce, late of 31 Finlayson Street, Malvern, home duties, died 3 February 1986.

Bray, Edward, formerly of 9 Belford Avenue, East Kew, but late of 2 Clovelly Court, Balwyn, widower, died 13 February 1986.

Bridges, Floris Louise Devereaux, late of Glengollan Village, 9A St. Elmo Avenue, Ferntree Gully, home duties, died 20 February 1986.

Bromley, Emily, formerly of Flat 2, 6 Tarakan Street (in the Will called Trakan Avenue), West Heidelberg, but late of Flat 11, 10 Louisa Street, Croydon, widow, died 20 December 1985.

Brown, Albert Edward, formerly of R.S.L. Park, Overport Road, Frankston, but late of The Mount Eliza Geriatric Centre, Jacksons Road, Mount Eliza, pensioner, died 26 February 1986.

Butler, Lester Michael, late of Flat 7, 31 Union Street, Brunswick, storeman/packer, died 1 October 1985.

Carlisle, Stephen Palmer, late of Bundoora, pensioner, died 19 December 1985.

Chatfield, John Leonard, late of 29 Allen Crescent, Traralgon, carpenter, died between 6 and 7 January 1986.

Cromie, Valma Irene, formerly of 82 North Road, East Reservoir, but late of Flat 2, 22 Beech Street, Whittlesea, retired boat trade employee, died 30 October 1985.

David, Pushpa, Richmond House, 353A Church Street, Richmond, retired secretary, died 3 November 1985.

Dess, Arthur Joseph, also known as Arthur Dess, late of Western Terrace Special Accommodation House, pensioner, died 13 January 1986.

Duff, Esther Vivien Ivy, late of Orrong Lodge, 19 Orrong Crescent, North Caulfield, widow, died 10 February 1986.

Edgar, Olive May, formerly of 213 Mitchell Street, Northcote, but late of Dowell Court Special Accommodation Home, 159 Lower Heidelberg Road, Ivanhoe, home duties, died 20 February 1986.

Foster, Athol Hilton, formerly of 2 Birdwood Avenue, Dandenong, but late of Flat 2, 107 Dorset Road, Boronia, pensioner, died 11 December 1985.

Garriga, Marion, formerly of 68 Craig Street, Newport, but late of Dalriada Private Nursing Home, 21 Railway Parade, Murrumbeena, pensioner, died 3 December 1985.

Gleeson, Robert Gussen, also known as Robert Cussen Gleeson, formerly care of 20 Darling Street, South Yarra, 382 Carlisle Street, Balaclava, retired chemical laboratory assistant, died 17 January 1986.

Goldberg, Ethel, late of Kew, pensioner, died 2 September 1985.

Howden, Leslie Roy, late of 24 Wilmoth Street, Northcote, pensioner, died 21 February 1986.

Hunt, Ernest Edward, late of 114 Cobden Street, South Melbourne, retired, died 1 February 1986.

Kelly, Benjamin Gerald Theodore, late of 240 Lancefield Road, Tullamarine, accountant, died 13 January 1972.

McIntyre, Emilie Amelia, late of 191 Booran Road, Glenhuntly, home duties, died 13 February 1986.

Mason, Leo Gavan, late of Flat 3, 81 Marley Street, Sale, retired, died 8 January 1986.

Moore, Janet Aileen, late of Pleasant Creek Training Centre, Western Highway, Stawell, pensioner, died 25 January 1986.

Morley, Agnes, late of Flat 1, 32 Edward Street, Essendon, home duties, died 18 January 1986.

Morris, Elvie Isabel, formerly of 9 Venice Street, Mornington, but late of Vermont Private Nursing Home, 770 Canterbury Road, Vermont, pensioner, died 27 January 1986.

Neill, Thomas Patrick, late of 43 Elphin Street, Ivanhoe, retired engineer, died 13 November 1984.

Page, Graham Alexander, late of 43 Miller Road, The Basin, courier, died 6 February 1986.

Parkinson, Alfred John, late of 3 Barkly Street, Ballarat, retired furnaceman, died 10 January 1986.

Potleca, Ermanno, also known as Edmundo Potleca, late of Flat 1, 371 Drummond Street, Carlton, labourer, died 27 January 1986.

Robinson, Mary Betheras, (formerly Prendergast), late of 5 Ebdon Avenue, Black Rock, widow, died 11 December 1985.

Sanders, Grace Annie, late of 13 David Street, Preston, widow, died 28 November 1985.

Seddon, John Eric, late of 16 Haydens Road, Beaumaris, pensioner, died 25 January 1986.

Smith, Boulton, late of 16 Poole Street, Deer Park, gentleman, died 25 February 1986.

Stern, Anton, late of Flat 3, 831 Park Street, Brunswick, pensioner, died 9 February 1986.

Thomson, Nellie, formerly of Kyneton, but late of Elgar Private Nursing Home, 366 Elgar Road, Box Hill, pensioner, died 23 October 1985.
Melbourne, 16 April 1986

P. T. SPENCER
Public Trustee

Education Act 1958

**NOTICE OF THE MAKING OF AN ORDER
UNDER SECTION 13 (1) OF THE ACT**

Pursuant to section 13 of the *Education Act 1958* I hereby give notice that an Order of the Governor in Council was made on 16 April 1986 under subsection (1) of the said Act constituting a Council for the Croydon Hills Primary School.

IAN CATHIE
Minister for Education

Education Act 1958

**NOTICE OF THE MAKING OF AN ORDER
UNDER SECTION 13 (4) OF THE ACT**

Pursuant to section 13 of the *Education Act 1958* I hereby give notice that Orders of the Governor in Council were made on 16 April 1986 under subsection (4) of the said Act amending certain provisions relating to the State School Councils listed below:

1373 Whorouly Primary School
1782 Dooen Primary School
2210 Barongarook Primary School
2773 Hedley Primary School
3067 Tallygaroopna Primary School
3195 Aireys Inlet Primary School
5111 Camelot Rise Primary School
5162 Djerriwarth Special Developmental School
5209 Doncaster East Special Developmental School
7760 Dandenong High School

IAN CATHIE
Minister for Education

Education Act 1958

**NOTICE OF THE MAKING OF AN ORDER
UNDER SECTION 13 (1) OF THE ACT**

Pursuant to section 13 of the *Education Act 1958* I hereby give notice that Orders of the Governor in Council were made on 16 April 1986 under subsection (1) of the said Act constituting councils for the State Schools listed below:

5241 Rolling Hills Primary School
5253 Mentone Autistic Special Developmental School

IAN CATHIE
Minister for Education

Forests Act 1958

PROCLAMATION OF PROTECTED FOREST

In pursuance of the powers conferred by section 58 (1) of the *Forests Act 1958*, I, Joan Elizabeth Kirner, Minister for Conservation, Forests and Lands hereby proclaim all unoccupied Crown land within the area described in the Schedule hereunder to be protected forest.

Schedule

Those areas within the Parishes of Monbulk, Mooroolbark, Narre Worrان, Scoresby and Wandin Yallock as indicated by red colour on plans 373/100001 and 373/100002 lodged in the Central Plan Office.

Dated 3 January 1986.

JOAN. E. KIRNER,
Minister for Conservation, Forests and Lands

Forests Act 1958
No. 6254

REVOCATION OF PROHIBITED PERIOD

In pursuance of the powers conferred by section 3 of the *Forests Act 1958*, I, Joan E. Kirner, Her Majesty's Minister for Conservation, Forests and Lands in the State of Victoria hereby vary the Declaration of a Prohibited Period previously made by me in the *Victoria Government Gazette* No. 125 dated 18 December 1985 insofar as it refers to the municipalities specified hereunder, and by this notice declare that in the specified municipalities the Prohibited Period in respect to any fire protected area (other than a State forest, national park or protected public land) shall end as specified hereunder.

Schedule 1

The Prohibited Period shall end at midnight between 23 and 24 April 1986 in the municipalities shown hereunder:

The Shires of Alexandra, Ararat, Avoca, Avon, Bacchus Marsh, Bairnsdale, Ballan, Ballarat, Bannockburn, Barrabool, Beechworth, Benalla, Bright, Broadford, Bungaree, Buninyong, Chiltern, Corio, Creswick, Daylesford and Glenlyon, Eltham, Euroa, Gisborne, Grenville, Healesville, Kilmore, Kyneton, Leigh, Lexton, Maffra, Mansfield, Melton, Myrtleford, Newham and Woodend, Omco, Oxley, Pakenham, Ripon, Romsey, Rosedale, Rutherglen, Seymour, Stawell, Tallangatta, Tambo, Traralgon, Upper Murray, Upper Yarra, Violet Town, Wangaratta, Whittlesea, Yackandandah and Yea; and

The Rural City of Wodonga; and

The Shires of Dundas and Mt Rouse—being those portions, in each shire, north of the Glenelg Highway.

JOAN E. KIRNER,
Minister for Conservation, Forests and Lands

ADOPTION ACT 1984

Pursuant to section 5 of the *Adoption Act 1984*, the Manager of Adoption Section, Delegate of the Director-General of Community Services has approved the following persons as counsellors:

Mission of St. James and St. John, 12
Batman Street, West Melbourne 3003
Storer, Shane Patrick
Cohen, Penelope
Spencer, Joan Ann

Dated 15 April 1986

LYNN GRAY
Manager, Adoption Section

Water Act 1958

**RURAL WATER COMMISSION OF
VICTORIA**

Employees' Representative
Result of Election

I hereby declare that, as a result of a poll conducted on 9 April 1986, in accordance with the Rural Water Commission Employees' Representative Regulations 1984, Charles Louis Sinn was elected as Employees' Representative to the Board of Management of the Rural Water Commission of Victoria with a majority of votes after preferences.

Mr Sinn's appointment will be for a period of two years from the date of this notice.

Dated 23 April 1986

F. C. O'CONNOR
Returning Officer

**APPOINTMENTS AND
RESIGNATIONS**

APPOINTMENTS

His Excellency the Governor of the State of Victoria by and with the advice of the Executive Council thereof has by Order made on 16 April 1986 been pleased to make the undermentioned appointments, viz:

Department of Health

Trustees of Public Cemeteries

Stanley JEANS,
William HIGGS,
William PETSCHACK,
Louchland MITCHELL,
George NOTMAN and
Walter PARSONS

to be Trustees of the Drouin West Cemetery Trust;
Additional Trustees

Robert DE GEUS
to be a Trustee of the Gipsy Point Cemetery Trust;
Additional Trustee

David HOLDEN
to be a Trustee of the Emerald Cemetery Trust;
Additional Trustee

Gary Lawrence PALMER,
Neville James MORRIS and
Max BENNETT-WOOD

to be Trustees of the Welshpool Cemetery Trust;
Additional Trustees

John HALLAS,
John VAN DOORN,
Geoffrey FERRIER,
Brian DOWEL and
Kenneth RICHARDS

to be Trustees of the Nyora Cemetery Trust;
Additional Trustees

Gavin MARSHMAN

to be a Trustee of the Beulah Cemetery Trust;
Additional Trustee

Colin John DEAN,

George ASTON Jnr,

Ian Robert PERRY and

Benjamin Bernard BROWNE

to be Trustees of the Landsborough Cemetery Trust;
Additional Trustees

*Members of the Committee of Management of
Hospitals*

Kathleen Ruth NIBLETT,
Lismore and District Hospital,
30 September 1988

Wallace Reginald EVANS,
Gippsland Base Hospital,
30 September 1988

to be Members of the Committee of Management
of the abovementioned hospitals pursuant to the
provisions of section 63H (2) of the *Hospitals and
Charities Act 1958* for the period of office expiring
on the dates indicated.

Law Department

Member of the Equal Opportunity Board

Con GEORGE

to be a Member of the Equal Opportunity Board
pursuant to section 8 of the *Equal Opportunity Act
1984*, for a period of three years from 7 May 1986
on a part-time basis.

Ministry for Police and Emergency Services

*Members of the Fire Brigades Board Appeal
Tribunal*

Lawrence Francis DREW

to be a member of the Metropolitan Fire Brigades
Board Appeal Tribunal pursuant to the provisions
of the *Metropolitan Fire Brigades Act 1958* and
Regulations, for a period ending 16 April 1988.

Kevin John BURGESS,

Stipendiary Magistrate

to be a member and Chairman of the Metropolitan
Fire Brigades Appeal Tribunal pursuant to the
provisions of the *Metropolitan Fire Brigades Act
1958* and Regulations, for the period ending 16 April
1988.

Kevin Geoffrey TAIT,

to be a member of the Metropolitan Fire Brigades
Appeal Tribunal pursuant to the provisions of the
Metropolitan Fire Brigades Act 1958, for the period
ending 16 April 1988.

L. G. HOUSTON

Clerk of the Executive Council

At the Executive Council Chamber
Melbourne, 16 April 1986

Liquor Control Act 1968
APPOINTMENT OF LICENSING
INSPECTORS

In accordance with the authority conferred upon
me by section 6 of the *Police Regulation Act 1958*,
I, Eric Archibald Mudge, Deputy Commissioner of
Police, do hereby appoint under sub-section (1) of
section 22 of the *Liquor Control Act 1968*, the
following Officers of Police as Licensing Inspectors
for the Divisions of the Police Districts as shown:

<i>Division Number</i>	<i>Police District</i>	<i>Rank and Name</i>
1	Cheltenham	Inspector Barrie Hamilton Stanton, 12821 (from 16.2.86 to 1.3.86)
3	Cheltenham	Inspector Barrie Hamilton Stanton, 12821 (from 2.2.86 to 15.2.86 and from 2.3.86 to 29.3.86)
1	Melbourne	Inspector Ian Henry Edward Henderson, 14670 (from 6.4.86 to 3.5.86)
2	Wimmera	Senior Sergeant Peter John Mintern-Lane, 14735 (from 2.4.86 to 7.5.86)

Dated 11 April 1986

E. A. MUDGE

Deputy Commissioner (Administration)

RESIGNATION

His Excellency the Governor of the State of
Victoria by and with the advice of the Executive
Council thereof has by Order made on 16 April
1986 accepted the resignation of the person named
hereunder of the office mentioned, viz:

Department of Health

Member of Committee of Management of Hospital
Burnett John, LANCASTER

as Member of the Committee of Management,
Moorabbin Hospital as from 31 March 1986 in
accordance with the provisions of section 63G (1)
of the *Hospitals and Charities Act 1958*.

L. G. HOUSTON

Clerk of the Executive Council

At the Executive Council Chamber
Melbourne, 16 April 1986

REVOCATION OF APPOINTMENTS

His Excellency the Governor of the State of
Victoria, by and with the advice of the Executive
Council thereof, has, by Orders made on 16 April
1986, revoked the appointment of the person named
hereunder to the office mentioned, viz:

Ministry for Police and Emergency Services

Member of the Metropolitan Fire Brigades Appeal Tribunal

William John PERRY

as member of the Metropolitan Fire Brigades Appeal Tribunal pursuant to the provisions of the Metropolitan Fire Brigades Act 1958 and Regulations, from the period ending 16 April 1986.

L. G. HOUSTON

Clerk of the Executive Council

At the Executive Council Chamber, Melbourne, 16 April 1986

ORDERS IN COUNCIL

Hospitals and Charities Act 1958
SECTION 5

At the Executive Council Chamber, Melbourne, the sixteenth day of April 1986

PRESENT:

His Excellency the Governor of Victoria

Mr Walker | Mr Spyker

Whereas pursuant to sub-section (1) (a) of section 5 of the *Hospitals and Charities Act 1958* (No. 6274) the Governor in Council may by Order published in the *Government Gazette* declare any hospital or asylum or institution affording charitable relief to be a "separate institution" within the meaning of the Act if such hospital asylum or institution is under the control of any religious denomination; and

Whereas pursuant to sub-section (2) (b) of section 5 of the said Act any Order published in the *Government Gazette* declares any hospital asylum or institution offering charitable relief to be a "separate institution" and the Third Schedule of that Act shall be deemed to have been amended accordingly.

Now therefore His Excellency the Governor of the State of Victoria by and with the advice of the Executive Council of the said State, doth hereby declare that Penola Hostel to be a separate institution within the meaning of the said Act and the Third Schedule shall be deemed to be amended accordingly.

And the Honourable David Ronald White, Her Majesty's Minister for Health for the State of Victoria, shall give the necessary directions herein accordingly.

L. G. HOUSTON
Clerk of the Executive Council

LAND ACT 1958

At the Executive Council Chamber, Melbourne, the sixteenth day of April 1986

PRESENT:

His Excellency the Governor of Victoria

Mr Walker | Mr Spyker

UNUSED ROAD CLOSED

His Excellency the Governor of the State of Victoria in the Commonwealth of Australia by and with the advice of the Executive Council of the said State, pursuant to the provisions of section 349 of the *Land Act 1958* and with the concurrence in writing of the council of the municipality concerned and that of any adjoining land owners, doth hereby close the unused road hereunder described, viz:

Municipal District of the Shire of Buninyong—Parish of Buninyong being the road indicated by hatching on plan hereunder—(L3-824).

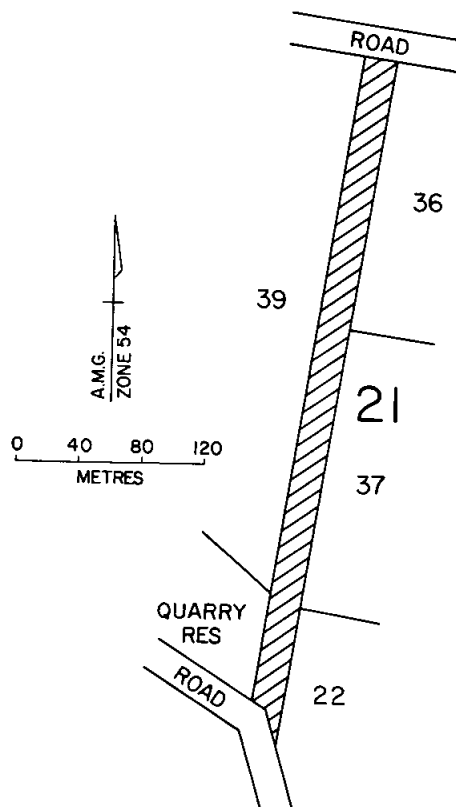

And the Honourable Joan Elizabeth Kirner, Her Majesty's Minister for Conservation, Forests and Lands for the State of Victoria, shall give the necessary directions herein accordingly.

L. G. HOUSTON
Clerk of the Executive Council

CROWN LAND (RESERVES) ACT 1978

At the Executive Council Chamber, Melbourne, the sixteenth day of April 1986

PRESENT:

His Excellency the Governor of Victoria
Mr Walker | Mr Spyker

CROWN LAND TEMPORARILY RESERVED

His Excellency the Governor of the State of Victoria, in the Commonwealth of Australia, by and with the advice of the Executive Council of the said State, pursuant to the provisions of sections 4 and 7 of the *Crown Land (Reserves) Act 1978* and being of the opinion that the Crown land concerned is required for the purposes mentioned hereby temporarily reserves and also excepts from prospecting or from occupation for mining purposes under any miners right the Crown land hereinafter described viz:

Municipal District of the City of Bendigo—Bendigo—for the Conservation of an Area of Historic Interest—661 square metres being Crown Allotment 206, Section A, at Bendigo, Parish of Sandhurst, as indicated by hatching on plan hereunder—(S372 (116)) (Rs 10813).

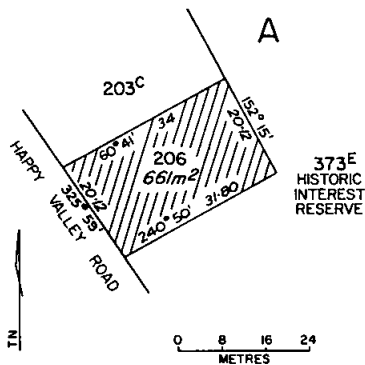

And the Honourable Joan Elizabeth Kirner, Her Majesty's Minister for Conservation, Forests and Lands for the State of Victoria shall give the necessary directions herein accordingly.

L. G. HOUSTON
Clerk of the Executive Council

CROWN LAND (RESERVES) ACT 1978

At the Executive Council Chamber, Melbourne, the sixteenth day of April 1986

PRESENT:

His Excellency the Governor of Victoria
Mr Walker | Mr Spyker

CROWN LAND TEMPORARILY RESERVED

His Excellency the Governor of the State of Victoria, in the Commonwealth of Australia by and with the advice of the Executive Council of the said State, pursuant to the provisions of sections 4 and 7 of the *Crown Land (Reserves) Act 1978* and being of the opinion that the Crown land concerned is required for the purposes mentioned, hereby temporarily reserve and also except from prospecting or from occupation for mining purposes under any miners right the Crown land hereinafter described viz:

Municipal District of the City of Coburg—Coburg—for Child Care Centre—861 square metres being Crown Allotment 30A, Township of Coburg, Parish of Jika Jika as indicated on Certified Plan No. 107632 lodged in the Central Plan Office—(Rs 13194).

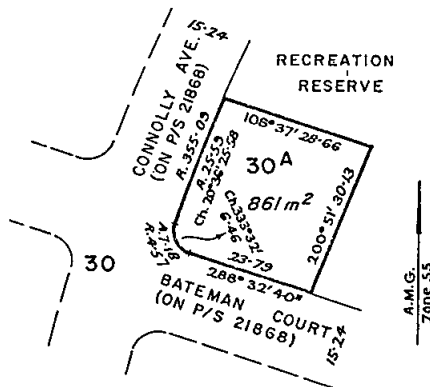

And the Honourable Joan Elizabeth Kirner, Her Majesty's Minister for Conservation, Forests and Lands for the State of Victoria shall give the necessary directions herein accordingly.

L. G. HOUSTON
Clerk of the Executive Council

CROWN LAND (RESERVES) ACT 1978

At the Executive Council Chamber, Melbourne, the sixteenth day of April 1986

PRESENT:

His Excellency the Governor of Victoria
Mr Walker | Mr Spyker

CROWN LAND TEMPORARILY RESERVED

His Excellency the Governor of the State of Victoria, in the Commonwealth of Australia by and with the advice of the Executive Council of the said State, pursuant to the provisions of sections 4 and 7 of the *Crown Land (Reserves) Act 1978* and being of the opinion that the Crown land concerned is required for the purposes mentioned, hereby temporarily reserves and also excepts from prospecting or from occupation for mining purposes under any miners right the Crown land hereinafter described viz:

Municipal District of the Shire of Donald—Donald—for Public Recreation—8094 square metres being Crown Allotment 30B, Parish of Jeffcott, as indicated by hatching on plan hereunder—(J 36 (4)) (Rs 12930).

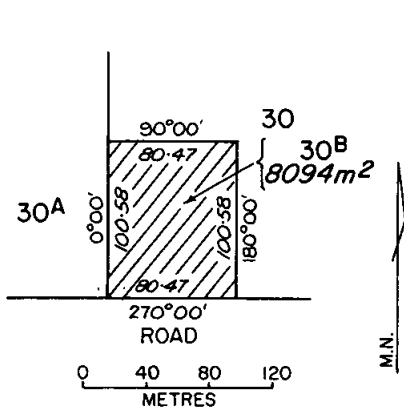

And the Honourable Joan Elizabeth Kirner, Her Majesty's Minister for Conservation, Forests and Lands for the State of Victoria shall give the necessary directions herein accordingly.

L. G. HOUSTON
Clerk of the Executive Council

CROWN LAND (RESERVES) ACT 1978

At the Executive Council Chamber, Melbourne, the sixteenth day of April 1986

PRESENT:

His Excellency the Governor of Victoria
Mr Walker | Mr Spyker

CROWN LAND TEMPORARILY RESERVED

His Excellency the Governor of the State of Victoria, in the Commonwealth of Australia by and with the advice of the Executive Council of the said State, pursuant to the provisions of sections 4 and 7 of the *Crown Land (Reserves) Act 1978* and being of the opinion that the Crown land concerned is required for the purposes mentioned, hereby temporarily reserves and also excepts from prospecting or from occupation for mining purposes under any miners right the Crown land hereinafter described viz:

Municipal District of the Shire of Myrtleford—Barwidgee—for the Public Hall and Public Recreation—2.022 hectares, being Crown Allotment 3C, Section 22, Parish of Barwidgee as shown on certified plan, No. 107765—(B 637 (8)) (Rs 13091).

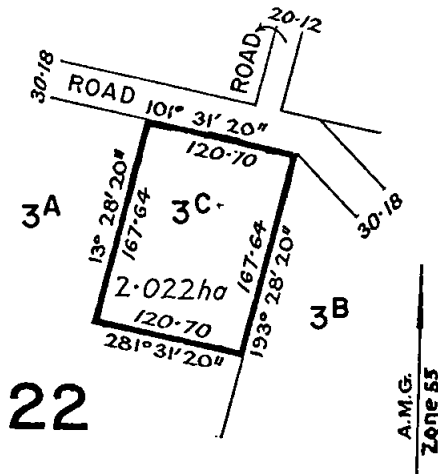

And the Honourable Joan Elizabeth Kirner, Her Majesty's Minister for Conservation, Forests and Lands for the State of Victoria shall give the necessary directions herein accordingly.

L. G. HOUSTON
Clerk of the Executive Council

CROWN LAND (RESERVES) ACT 1978

*At the Executive Council Chamber, Melbourne, the
sixteenth day of April 1986*

PRESENT:

His Excellency the Governor of Victoria
Mr Walker | Mr Spyker

REVOCATION OF TEMPORARY
RESERVATIONS AS TO PART BY ORDER IN
COUNCIL

His Excellency the Governor of the State of Victoria, in the Commonwealth of Australia by and with the advice of the Executive Council of the said State, pursuant to the provisions of section 10 of the *Crown Land (Reserves) Act 1978*, doth hereby revoke the temporary reservations of land by Orders in Council hereinafter described, viz:

Sandhurst—The temporary reservation by Order in Council of 23 November 1868 for railway purposes of land comprised within the limits of deviation of the surveyed line of railway from Melbourne to Echuca so far only as the portion thereof at Bendigo in the Parish of Sandhurst containing 1-426 hectares shown as Allotment 16 section 11A as indicated on Certified Plan 107684 lodged in the Central Plan Office—(L6-1959).

Meredith—The temporary reservation by Order in Council of 23 November 1868 for railway purposes of land comprised within the line of railway from Melbourne to Ballarat so far only as the portion thereof in the Parish of Meredith containing 2503 square metres being Crown Allotment 200E, as indicated on Certified Plan 107807 lodged in the Central Plan Office—(L1-1646).

Tandarook—The temporary reservation by Order in Council of 24 April 1888 of 9637 square metres of land in the Parish of Tandarook (adjoining south of freehold Allotment 0 section 10) as a site for a State School.

Killingworth—The temporary reservation by Order in Council of 9 August 1881 of 9 hectares more or less of land in the Parish of Killingworth as a site for public purposes—(Rs. 2237).

Merrinee—The temporary reservation by Order in Council of 1 September 1924 of 2 hectares of land in the Township of Merrinee as a site for a State School—(Rs. 2983).

Benalla—The temporary reservation by Order in Council of 13 January 1967 of 581 square metres of land being Crown Allotment 7 section 22, Township of Benalla as a site for a public purpose (Departmental Residence)—(Rs. 10090).

Moondarra—The temporary reservation by Order in Council of 16 October 1967 of 1037 square metres of land in the Parish of Moondarra (adjoining freehold Allotment 4 section B) as a site for public purposes (Forest Department Purposes)—(Rs. 8864).

Moondarra—The temporary reservation by Order in Council of 5 May 1970 of 486 square metres of land in the Parish of Moondarra (adjoining freehold Allotment 4 section B) as a site for public purposes (Forest Department Purposes)—(Rs. 8864).

Bolton—The temporary reservation by Order in Council of 27 February 1924 of 1-997 hectares of land in the Township of Bolton as a site for a State School—(Rs. 2888).

Burrumbidgee—The temporary reservation by Order in Council of 30 October 1873 of 6-475 hectares of land in the Parish of Burrumbidgee as a site for public purposes—(Rs. 3346).

And the Honourable Joan Elizabeth Kirner, Her Majesty's Minister for Conservation, Forests and Lands for the State of Victoria, shall give the necessary directions herein accordingly.

L. G. HOUSTON
Clerk of the Executive Council

Audit Act 1958, No. 6203
TREASURY REGULATIONS 1981

*At the Executive Council Chamber, Melbourne, the
sixteenth day of April 1986*

PRESENT:

His Excellency the Governor of Victoria
Mr Walker | Mr Spyker

Whereas, paragraph (a) of Regulation 71 (2) of the Treasury Regulations 1981 provides that Regulation 71 shall not apply in respect of the invitation of tenders to expenditure specifically authorized by the Governor in Council on the recommendation of the Treasurer.

And whereas the Treasurer has recommended that the expenditure detailed hereunder be specifically authorized by the Governor in Council.

Now therefore, pursuant to the powers conferred on him by the Treasury Regulations 1981 and all other powers enabling him in that behalf, His Excellency the Governor of the State of Victoria, by and with the advice of the Executive Council thereof, does hereby authorize the expenditure of an amount not exceeding twenty-nine thousand one hundred and seventy-seven dollars (\$29,177) by payment to Honeywell Proprietary Limited for word processing equipment Maintenance Service Agreements.

And the Honourable Charles Race Thorson Mathews, Her Majesty's Minister for Police and Emergency Services for the State of Victoria, shall give the necessary directions herein accordingly.

L. G. HOUSTON
Clerk of the Executive Council

Audit Act 1958
TREASURY REGULATIONS 1981

*At the Executive Council Chamber, Melbourne, the
 sixteenth day of April 1986*

PRESENT:

His Excellency the Governor of Victoria
 Mr Walker | Mr Spyker

His Excellency the Governor of the State of Victoria in the Commonwealth of Australia by and with the advice of the Executive Council of the said State, and in pursuance of the powers conferred by Regulation 71 (2) (a) of the Treasury Regulations 1981, and all other powers him thereunto enabling, doth by this Order authorize the expenditure of not more than Fifty thousand dollars (\$50 000) by payment to Mr Werner Brog for provision of consultancy services in the fields of Behavioural and Market Research for the Youth Guarantee Programme and Occupational Health and Safety Awareness Programme.

And the Honourable Steven Marshall Crabb, Her Majesty's Minister for Labour for the State of Victoria, shall give the necessary directions herein accordingly.

L. G. HOUSTON
 Clerk of the Executive Council

Audit Act 1958
TREASURY REGULATIONS 1981

*At the Executive Council Chamber, Melbourne, the
 sixteenth day of April 1986*

PRESENT:

His Excellency the Governor of Victoria
 Mr Walker | Mr Spyker

His Excellency the Governor of the State of Victoria in the Commonwealth of Australia by and with the advice of the Executive Council of the said State, and in pursuance of the powers conferred by Regulation 71 (2) (a) of the Treasury Regulations 1981, and all other powers him thereunto enabling, doth by this Order authorize the expenditure of not more than Three thousand dollars, (\$3000) by payment to Scali McCabe and Sloves for provision of professional services in the preparation of advertising, media and publicity material for the Occupational Health and Safety Awareness Programme.

And the Honourable Steven Marshall Crabb, Her Majesty's Minister for Labour for the State of Victoria, shall give the necessary directions herein accordingly.

L. G. HOUSTON
 Clerk of the Executive Council

MOTOR CAR ACT 1958

*At the Executive Council Chamber, Melbourne, the
 sixteenth day of April 1986*

PRESENT:

His Excellency the Governor of Victoria
 Mr Walker | Mr Spyker

**MOTOR CAR TRIALS OF SPEED WITHIN
 THE CRESWICK AND MARYBOROUGH
 FOREST AREAS AND THE SCHOOL OF
 FORESTRY DEMONSTRATION FOREST**

Whereas it is enacted by sub-sections (1) and (2) of section 83A of the *Motor Car Act 1958* that, if a motor car is used on a highway for purposes of racing or of trial of speed, and if a race or trial of speed is organized or managed, the driver or the person in charge thereof and the person organizing or managing the race or trial of speed, shall be liable to a penalty of not more than five hundred dollars for the first offence and one thousand dollars for the second offence, provided that the said sub-sections (1) and (2) shall not apply to a motor car used as aforesaid or to a race or trial of speed on any highway or portion thereof specified by Order in Council published in the *Government Gazette* and on such days and during such hours as are specified in the Order;

And whereas the Light Car Club of Australia has requested that such an Order be made to enable an event known as the "Maryborough Nissan—Nissan Finance Corporation Blue Ribbon Rally" to be conducted by the said club on 26 April 1986;

Now therefore, His Excellency the Governor of the State of Victoria, by and with the advice of the Executive Council thereof, and in pursuance of the powers conferred by the *Motor Car Act 1958* and all other powers him thereunto enabling, doth order that the provisions of sub-sections (1) and (2) of section 83A of the *Motor Car Act 1958* and of the regulations made under Part VI. of the *Transport Act 1983* shall not apply with respect to the event known as the Maryborough Nissan—Nissan Finance Corporation Blue Ribbon Rally to be held on sections of road within the Creswick and Maryborough Forest areas and the School of Forestry Demonstration Forest all under the control of the Department of Conservation, Forests and Lands on 26 April 1986 between the hours of 9.30 in the forenoon and 6.30 in the afternoon.

And the Honourable Thomas William Roper, Her Majesty's Minister for Transport for the State of Victoria, shall give the necessary directions herein accordingly.

L. G. HOUSTON
 Clerk of the Executive Council

**WEST MOORABOOL WATER BOARD ACT
1968**

*At the Executive Council Chamber, Melbourne, the
sixteenth day of April 1986*

PRESENT:

His Excellency the Governor of Victoria
Mr Walker | Mr Spyker

**APPOINTMENT OF A MEMBER OF THE
WEST MOORABOOL WATER BOARD**

Under the powers conferred by the *West Moorabool Water Board Act 1968* and all other powers enabling him in that behalf, His Excellency the Governor of the State of Victoria, by and with the advice of the Executive Council of the said State doth hereby appoint Raymond William George Evans as a Member of the West Moorabool Water Board for a period of three years from 20 June 1986.

And the Honourable Andrew McCutcheon, Her Majesty's Minister for Water Resources for the State of Victoria, shall give the necessary directions herein accordingly.

L. G. HOUSTON
Clerk of the Executive Council

**WATER AND SEWERAGE AUTHORITIES
(RESTRUCTURING) ACT 1983
WATER ACT 1958**

*At the Executive Council Chamber, Melbourne, the
sixteenth day of April 1986*

PRESENT:

His Excellency the Governor of Victoria
Mr Walker | Mr Spyker

**KYNETON WATER BOARD—
SITE OF PIPELINE APPROVED**

Under the powers conferred by the *Water and Sewerage Authorities (Restructuring) Act 1983*, the *Water Act 1958* and all other powers enabling him in that behalf, His Excellency the Governor of the State of Victoria, by and with the advice of the Executive Council of the said State, doth hereby approve of the site of a pipeline as required by the Kyneton Water Board and shown by red colour on the plan approved by the Governor in Council, by and with this Order and deposited in the Office of the Department of Water Resources, Melbourne (Corr. No. 85/863/21).

And the Honourable Andrew McCutcheon, Her Majesty's Minister for Water Resources for the State of Victoria, shall give the necessary directions herein accordingly.

L. G. HOUSTON
Clerk of the Executive Council

**WATER AND SEWERAGE AUTHORITIES
(RESTRUCTURING) ACT 1983
MILDURA IRRIGATION TRUSTS AND
SUNRAYSIA WATER BOARD ACT 1958**

*At the Executive Council Chamber, Melbourne, the
sixteenth day of April 1986*

PRESENT:

His Excellency the Governor of Victoria
Mr Walker | Mr Spyker

**FIRST MILDURA IRRIGATION TRUST
SUNRAYSIA WATER BOARD
EXCISION FROM THE DISTRICT OF THE
FIRST MILDURA IRRIGATION TRUST
DISTRICT AND ANNEXATION TO THE
SUNRAYSIA WATER BOARD DISTRICT**

Under the powers conferred by the *Water and Sewerage Authorities (Restructuring) Act 1983*, the *Mildura Irrigation Trusts and Sunraysia Water Board Act 1958* and all other powers enabling him in that behalf, His Excellency the Governor of the State of Victoria, by and with the advice of the Executive Council of the said State, doth hereby declare, order and direct that as on and from the date hereof the lands shown by pink colour on the plans marked "A", "B", "C", "D", "E" and "F" approved by the Governor in Council by and with this Order and deposited in the office of the Department of Water Resources, Melbourne (Corr. No. 80/4325/132, 133, 134 and 135) shall be excised from the District of the First Mildura Irrigation Trust and annexed to the Water Supply District of the Sunraysia Water Board.

And the Honourable Andrew McCutcheon, Her Majesty's Minister for Water Resources for the State of Victoria, shall give the necessary directions herein accordingly.

L. G. HOUSTON
Clerk of the Executive Council

LATROBE VALLEY ACT 1958

*At the Executive Council Chamber, Melbourne, the
sixteenth day of April 1986*

PRESENT:

His Excellency the Governor of Victoria
Mr Walker | Mr Spyker

**LATROBE VALLEY WATER AND
SEWERAGE BOARD
CROWN LAND TO BE VESTED WITH THE
LATROBE VALLEY WATER AND
SEWERAGE BOARD**

Under the powers conferred by the *Latrobe Valley Act 1958*, and all other powers enabling him in that behalf, His Excellency the Governor of the State of

Victoria, by and with the advice of the Executive Council of the said State, doth hereby declare that the Crown land being part of Crown Allotment 11A, section B, Parish of Tangil East, County of Tangil, as shown by pink colour on the plan approved by the Governor in Council, by and with this Order and deposited in the Office of the Department of Water Resources, Melbourne (Corr. No. 82/2278/26) shall be vested with the Latrobe Valley Water and Sewerage Board.

And the Honourable Andrew McCutcheon, Her Majesty's Minister for Water Resources for the State of Victoria, shall give the necessary directions herein accordingly.

L. G. HOUSTON
Clerk of the Executive Council

MELBOURNE CRICKET GROUND ACT 1984

At the Executive Council Chamber, Melbourne, the sixteenth day of April 1986

PRESENT:

His Excellency the Governor of Victoria
Mr Walker | Mr Spyker

His Excellency the Governor of the State of Victoria in the Commonwealth of Australia, by and with the advice of the Executive Council of the said State pursuant to the provisions of section 3 (3) of the *Melbourne Cricket Ground Act 1984*, doth hereby approve the floodlights affixed to the floodlight towers on the Melbourne Cricket Ground being operated on Friday 25 April 1986 for the purpose of playing a Victorian Football League home and away match—North Melbourne versus Geelong.

And the Honourable Joan Elizabeth Kirner, Her Majesty's Minister for Conservation, Forests and Lands for the State of Victoria, shall give the necessary directions herein accordingly.

L. G. HOUSTON
Clerk of the Executive Council

STAMPS ACT 1958, No. 6375

At the Executive Council Chamber, Melbourne, the sixteenth day of April 1986

PRESENT:

His Excellency the Governor of Victoria
Mr Walker | Mr Spyker

ORDER PURSUANT TO SECTION 7 (1) OF THE STAMPS ACT 1958

Whereas section 7 (1) of the *Stamps Act 1958* provides that the Governor in Council may by Order published in the *Government Gazette* direct that all or any of the fees which under Part 1 of the *Stamps Act 1958* are at the time of making such Order

required to be collected by stamps may from the time named in the Order be collected by money instead of stamps:

Now therefore, His Excellency the Governor of the State of Victoria, by and with the advice of the Executive Council thereof, and pursuant to the provisions of the said section 7 (1) hereby directs:

(1) That all fees payable pursuant to the Magistrates' Courts Rules 1980 with respect to matters under Part VIIA of the *Magistrates (Summary Proceedings) Act 1975*, be collected in money instead of stamps.

(2) That this Order shall have effect as from and including 1 May 1986.

And the Honourable Robert Allen Jolly, Her Majesty's Treasurer for the State of Victoria, shall give the necessary directions herein accordingly.

L. G. HOUSTON
Clerk of the Executive Council

NATIONAL PARKS ACT 1975

At the Executive Council Chamber, Melbourne, the sixteenth day of April 1986

PRESENT:

His Excellency the Governor of Victoria
Mr Walker | Mr Spyker

His Excellency the Governor of the State of Victoria, in the Commonwealth of Australia, by and with the advice of the Executive Council of the said State, pursuant to the provisions of section 19F of the *National Parks Act 1975* doth by this Order:

1. Declare that certain areas of land listed in Schedule A managed by the Director of National Parks pursuant to section 19B of the National Parks Act shall be areas of land to which the provisions of the Act and Regulations shall apply as specified in Schedule A as though the land were a park;

2. Amend Schedule Four to the National Park Act in accordance with Schedule A; and

3. Specify the provisions of the Act and Regulations to apply to each area.

SCHEDULE A

AMENDMENTS TO SCHEDULE FOUR

Areas of land added to Schedule Four to the National Parks Act immediately after the heading "SCHEDULE":

PART I—WILSONS PROMONTORY MARINE RESERVE

Description

Crown land temporarily reserved for the conservation of areas of natural interest or beauty or scientific history or archaeological interest and shown coloured pink on plan NPMR1 lodged in the Central Plan Office in the Department of Property

and Services except any land reserved as a national park or declared or deemed to be reserved for any purpose under the *Crown Land (Reserves) Act 1978* and any land proclaimed or set aside as a road or any land for which permission to occupy has been given by the Crown or a licence or lease under the *Land Act 1958* is in force by Orders in Council of 18 March 1986 (see *Government Gazette* dated 26 March 1986).

Section of the Act under which land is managed
19B

Date of Appointment of Director to Manage Land
18 March 1986, *Gazette* 26 March 1986.

Provisions of the Act to apply to the land

Sections 1 to 6 inclusive, 9 to 27 inclusive, 33 (3), 35 to 39 inclusive, 40 to 48 inclusive.

Application of the Regulations to the land

Park Regulations 1984—S.R. No. 407/84—as amended by S.R. Nos. 262/85 and 282/86.

PART 2—WILSONS PROMONTORY MARINE PARK

Description

Crown land shown coloured yellow on plan NPMR1 lodged with the Central Plan Office of the Department of Property and Services except any land reserved as a national park or declared or deemed to be reserved for any purpose under the *Crown Land (Reserves) Act 1978* or any other Act which reserves Crown land and any land proclaimed or set aside as a road or any land for which permission to occupy has been given by the Crown or a licence or lease under the *Land Act 1958* is in force.

Section of the Act under which land is managed
19B

Date of Appointment of Director to Manage Land
18 March 1986, *Gazette* 26 March 1986.

Provisions of the Act to apply to the land

Sections 1 to 6 inclusive, 9 to 27 inclusive, 33 (3), 36 to 39 inclusive and 40 to 48 inclusive.

Application of the Regulations to the land

Park Regulations 1984—S.R. No. 407/84—as amended by S.R. Nos. 262/85 and 282/86.

PART 3—SHALLOW INLET MARINE AND COASTAL PARK

Description

Crown land temporarily reserved for the conservation of areas of natural interest or beauty or scientific history or archaeological interest and areas for public recreation and shown coloured blue on plan NPMR1 lodged in the Central Plan Office in the Department of Property and Services except any land reserved as a national park or declared or deemed to be reserved for any purpose under the *Crown Land (Reserves) Act 1978* and any land proclaimed or set aside as a road or any land for

which permission to occupy has been given by the Crown or a licence or lease under the *Land Act 1958* is in force by Orders in Council of 18 March 1986 (see *Government Gazette* dated 26 March 1986).

Section of the Act under which land is managed

19B

Date of Appointment of Director to Manage Land
18 March 1986, *Gazette* 26 March 1986.

Provisions of the Act to apply to the land

Sections 1 to 6 inclusive, 9 to 27 inclusive, 33 (3), 35 to 39 inclusive and 40 to 48 inclusive.

Application of the Regulations to the land

Park Regulations 1984—S.R. No. 407/84—as amended by S.R. Nos. 262/85 and 282/86.

PART 4—CORNER INLET MARINE AND COASTAL PARK

Description

Crown land temporarily reserved for the conservation of areas of natural interest or beauty or scientific history or archaeological interest and areas for public recreation and shown coloured green on plan NPMR1 lodged in the Central Plan Office in the Department of Property and Services except any land reserved as a national park or declared or deemed to be reserved for any purpose under the *Crown Land (Reserves) Act 1978* and any land proclaimed or set aside as a road or any land for which permission to occupy has been given by the Crown or a licence or lease under the *Land Act 1958* is in force by Orders in Council of 18 March 1986 (see *Government Gazette* dated 26 March 1986).

Section of the Act under which land is managed

19B

Date of Appointment of Director to Manage Land
18 March 1986, *Gazette* 26 March 1986.

Provisions of the Act to apply to the land

Sections 1 to 6 inclusive, 9 to 29 inclusive, 33 (3), 35 to 39 inclusive and 40 to 48 inclusive.

Application of the Regulations to the land

Park Regulations 1984—S.R. No. 407/84—as amended by S.R. Nos. 262/85 and 282/86.

PART 5—NOORAMUNGA MARINE AND COASTAL PARK

Description

Crown land temporarily reserved—

- (a) for conservation of areas of natural interest or beauty or scientific history or archaeological interest and areas for public recreation and shown coloured orange, on plan NPMR1 lodged in the Central Plan Office in the Department of Property and Services except any land reserved as a national park or declared or deemed to be reserved for any purpose under the *Crown Land (Reserves) Act 1978* and any land proclaimed or set aside as a road or any land

for which permission to occupy has been given by the Crown or a licence or lease under the *Land Act* 1958 is in force by Orders in Council of 18 March 1986 (see *Government Gazette* dated 26 March 1986); and

- (b) for the conservation of an area of natural interest or beauty being allotment 5A, Parish of St. Margaret and allotments 17A4, 52A, 52B and part allotment 20B6, Parish of Balloong, formerly contained in Freehold Certificates of Title Volume 5825 Folio 853, Volume 8753 Folio 466, Volume 4226 Folio 95 and Volume 6293 Folio 555.

Section of the Act under which land is managed
19B

Date of Appointment of Director to Manage Land
18 March 1986, *Gazette* 26 March 1986.

Provisions of the Act to apply to the land

Sections 1 to 6 inclusive, 9 to 27 inclusive, 33 (3), 35 to 39 inclusive and 40 to 48 inclusive.

Application of the Regulations to the land

Park Regulations 1984—S.R. No. 407/84—as amended by S.R. Nos. 262/85 and 282/86.

And the Honourable Joan Elizabeth Kirner, Her Majesty's Minister for Conservation, Forests and Lands for the State of Victoria, shall give the necessary directions herein accordingly.

L. G. HOUSTON
Clerk of the Executive Council

CREDIT ACT 1984

At the Executive Council Chamber, Melbourne, the sixteenth day of April 1986

PRESENT:

His Excellency the Governor of Victoria
Mr Walker | Mr Spyker

CREDIT ORDER No. 32—STATEMENT OF ACCOUNT

In pursuance of the powers conferred by section 19 of the *Credit Act* 1984, His Excellency the Governor of the State of Victoria in the Commonwealth of Australia, by and with the advice of the Executive Council of the said State, doth by this Order provide as follows:

Citation

1. This Order may be cited as "Credit Order No. 32—Statement of Account".

Commencement

2. This Order shall take effect on and from 15 April 1986.

Statement of Account—Exemption

3. Section 126 of the *Credit Act* 1984 does not have effect in relation to a statement of account required to be given under section 61 of that Act

where the statement of account relates to an account of a debtor constituted by 2 or more persons residing at the same address or having the same address for service of the document.

And the Honourable Peter Cornelis Spyker, Her Majesty's Minister for Consumer Affairs shall give the necessary directions herein accordingly.

L. G. HOUSTON
Clerk of the Executive Council

CREDIT ACT 1984

At the Executive Council Chamber, Melbourne, the sixteenth day of April 1986

PRESENT:

His Excellency the Governor of Victoria
Mr Walker | Mr Spyker

CREDIT ORDER No. 15H—MULTIPLE CARD SYSTEMS

In pursuance of the powers conferred by section 19 of the *Credit Act* 1984, His Excellency the Governor of the State of Victoria in the Commonwealth of Australia, by and with the advice of the Executive Council of the said State, doth by this Order provide as follows:

Citation

1. This Order may be cited as "Credit Order No. 15H—Multiple Card Systems".

Commencement

2. This Order shall take effect on and from 15 April 1986.

Multiple Card Systems—Exemption

3. Sections 52, 54 (2), 55 (1) and 59 (1) (b) of the *Credit Act* 1984 do not have effect in relation to Multiple Card Systems Pty Ltd to the extent that it enters into continuing credit contracts.

And the Honourable Peter Cornelis Spyker, Her Majesty's Minister for Consumer Affairs shall give the necessary directions herein accordingly.

L. G. HOUSTON
Clerk of the Executive Council

HOSPITALS AND CHARITIES ACT 1958 SECTION 63G (2)

At the Executive Council Chamber, Melbourne, the sixteenth day of April 1986

PRESENT:

His Excellency the Governor of Victoria
Mr Walker | Mr Spyker

Whereas by section 63G of the *Hospitals and Charities Act* 1958 it is enacted that the Governor in Council may, on the recommendation of the Chief General Manager of the Department of Health and

the Minister for Health, remove a member of the Committee of the Scheduled Hospital, or all the members of the Committee of a Scheduled Hospital, from office;

And whereas the Seymour District Memorial Hospital is a scheduled hospital pursuant to the provisions of the *Hospitals and Charities Act 1958*;

And whereas the Chief General Manager of the Department of Health and the Minister for Health have recommended that a member of the Seymour District Memorial Hospital Committee of Management should be removed from office;

Now therefore His Excellency the Governor of the State of Victoria, by and with the advice of the Executive Council of the said State, hereby removes a member of the Seymour District Memorial Hospital Committee of Management from office, namely: Dennis Charles Furneyvall

And the Honourable David Ronald White, Her Majesty's Minister for Health for the State of Victoria, shall give the necessary directions herein accordingly.

L. G. HOUSTON
Clerk of the Executive Council

CROWN LAND (RESERVES) ACT 1978

At the Executive Council Chamber, Melbourne, the twenty-second day of April 1986

PRESENT:

His Excellency the Governor of Victoria

Mrs Hogg
Mr Cathie

Mr Trezise

WANGARATTA SHOWGROUNDS AND PUBLIC RECREATION RESERVE VESTED IN THE CITY OF WANGARATTA

His Excellency the Governor of the State of Victoria, in the Commonwealth of Australia, by and with the advice of the Executive Council of the said State, pursuant to section 16 (1) of the *Crown Land (Reserves) Act 1978*, doth hereby direct that the Crown land described in the Schedule hereunder be vested in the municipality of the City of Wangaratta on trust for the purposes for which the land has been reserved, and, pursuant to section 16 (2) of the said Act, doth also empower the said municipality to grant leases and licences for a term not exceeding 21 years in respect of the land for the purposes of the reservation.

SCHEDULE

The reserved Crown land in the Township of Wangaratta as shown hatched on plan marked W/18.4.86 attached to Department of Conservation, Forests and Lands correspondence Rs 2007 and known as the "Wangaratta Showgrounds and Public Recreation Reserve".

And the Honourable Joan Elizabeth Kirner, Her Majesty's Minister for Conservation, Forests and Lands for the State of Victoria, shall give the necessary directions herein accordingly.

L. G. HOUSTON
Clerk of the Executive Council

CROWN LAND (RESERVES) ACT 1978

At the Executive Council Chamber, Melbourne, the twenty-second day of April 1986

PRESENT:

His Excellency the Governor of Victoria

Mrs Hogg
Mr Cathie

Mr Trezise

CROWN LAND TEMPORARILY RESERVED

His Excellency the Governor of the State of Victoria, in the Commonwealth of Australia, by and with the advice of the Executive Council of the said State, pursuant to the provisions of sections 4 and 7 of the *Crown Land (Reserves) Act 1978* and being of the opinion that the Crown land concerned is required for the purposes respectively mentioned, hereby temporarily reserves and also excepts from prospecting or from occupation for mining purposes under any miner's right the Crown land hereinafter described viz:

Municipal District of the Shire of Alexandra—

Gobur—for Public Purposes—3.742 hectares, more or less, being allotment 11, Section 15, Township of Gobur, Parish of Gobur, as indicated on Certified Plan 107919 lodged in the Central Plan Office (Rs 12772).

Municipal District of the City of Wangaratta—

Wangaratta—for Public Recreation—28.14 hectares, being Crown allotment A, Township of Wangaratta, Parish of Wangaratta North as indicated on Certified Plan 107609 lodged in the Central Plan Office (Rs 2441).

Municipal District of the City of Wangaratta—

Wangaratta—for Institution—834 square metres, being Crown allotment B, Township of Wangaratta, Parish of Wangaratta North as indicated on Certified Plan 107609 lodged in the Central Plan Office (Rs 8753)

And the Honourable Joan Elizabeth Kirner, Her Majesty's Minister for Conservation, Forests and Lands for the State of Victoria shall give the necessary directions herein accordingly.

L. G. HOUSTON
Clerk of the Executive Council

TENDERS

PUBLIC WORKS DEPARTMENT

Tenders are invited for the purposes indicated hereunder and will be received at 2 Treasury Place, Melbourne, 3002, until TWO p.m. on the dates shown.

Tenders must be addressed to the Minister for Public Works with the envelope endorsed "Tender for "

Tenders forwarded either by mail, telegram or telex, which arrive after the closing time, will be accepted provided that the official Telecom or Australia Post time and date stamping indicates dispatch prior to the closing time. (TIME AND DATE STAMPING MUST BE REQUESTED AT SOME POST OFFICES.)

(TELEX No. AA152039)

Hand-delivered tenders must be placed in the Department's tender box in foyer, Ground Floor, 2 Treasury Place, Melbourne.

Tender documents are available from the Contracts Office, Room 29, Ground Floor, 2 Treasury Place, Melbourne and, where indicated, at offices of Inspector of Works.

★Tenders identified with a star (★) will only be considered from contractors qualified for repairs and painting works. Any tenderers wishing to qualify may obtain the application form from the Contracts Office.

Wednesday, 7 May 1986

Building, Electrical and Mechanical Services

BALLARAT NORTH—Automotive practices upgrade, Technical School (W.O. Ballarat).

KEILOR HEIGHTS—Internal and external repairs and painting, Primary School.

NADRASCA—Staff/Administration and withdrawal rooms upgrade, Special Development School.

WEDDERBURN—Conversion of court house to police station, Court House (W.O. Bendigo).

Miscellaneous

BALLARAT—Supply of automotive equipment, engines etc. T1077, School of Mines and Industries.

BALLARAT—Supply of kiln and kiln furniture, School of Mines and Industries.

KNOX (OUTER EASTERN)—Supply of kilns and pyrometers, College of T.A.F.E.

MELBOURNE—Supply and installation of communication system for new police helicopters, T1085, 376 Russell Street, Police Complex.

PORT MELBOURNE—Purchase of four (4) only diesel-engine, dual-cab tipping trucks, 2.5 cubic metre body, P.W.D. Storeyard, 69 Salmon Street.

Wednesday, 14 May 1986

Building, Electrical and Mechanical Services

FRANKSTON—Intruder detection services, College of T.A.F.E.

GARDINER—Provision of student toilets in found space, Central School.

PRESTON—Alterations and additions to 2 relocatable classrooms to provide hospitality classroom unit, College of T.A.F.E.

RED HILL—Internal repairs and painting, Consolidated School.

WATSONIA—Installation of new cool rooms and renovations to kitchen, Staff Training College.

RONALD W. WALSH

Minister for Public Works

Public Works Department
Melbourne, 21 April 1986

DEPARTMENT OF PROPERTY AND SERVICES VICTORIA

Tenders are invited for the services indicated hereunder and will be received at the Property Division, Department of Property and Services, 3rd Floor, 35 Spring Street, Melbourne 3000 until Two p.m. on the dates shown.

Specifications and Tender documents are available from the Property Division Office at the above address (phone 651 3581) or, where indicated, at other locations.

Late tenders will not be considered.

Wednesday, 7 May 1986

MILDURA—Security Patrol Service, period 1.6.86 to 31.5.87, Public Offices, cnr Langtree Parade and 11th Avenue.

ECHUCA—Maintenance cleaning, period 1.6.86 to 31.5.89, Court House (documents available at Echuca Police Station).

NORTH FITZROY—Maintenance cleaning, period 1.6.86 to 31.5.89, Dental Health Clinic, 658 Nicholson Street.

Dr E. W. RUSSELL

Director-General of Property and Services

PRIVATE ADVERTISEMENTS

CITY OF CAMBERWELL

Road Discontinuance

Pursuant to section 528 (2) of the *Local Government Act 1958*, the Council of the City of Camberwell has resolved that part of a road abutting 61 Glen Iris Road, Glen Iris which is shown by hatching on the plan herewith, and which has been closed under the City of Camberwell Local Development Scheme approved on 3 April 1985 be discontinued, subject to—

- (a) the Melbourne and Metropolitan Board of Works continuing to have and possess the same right, title, power, authority or interest

- in or in relation to the whole of the land shown by hatching on the said plan as it had or possessed prior to such discontinuance with respect to or in connection with any drains or pipes laid or erected in on or over such land for the purposes of drainage or sewerage;
- (b) the City of Camberwell continuing to have and possess the same right, title, power, authority or interest in or in relation to the whole of the land shown by hatching on the said plan as it had or possessed prior to such discontinuance with respect to or in connection with any drains or pipes laid or erected in on or over such land for the purposes of drainage or sewerage;
 - (c) the land in the said road subject to any such right, title, power, authority or interest vesting in the municipality to be retained by it until sold by private treaty.

Committee, being a Committee duly appointed under section 193A of the *Local Government Act* 1958, and the recommendations of that Committee for Council to consider the objections and Council having considered objections to the proposed closure and sale of the nominal 6.1 metre wide access track shown as Tuckers Road, Access Road north from the corner of Serpells Road and Tuckers Road, shown on L.P.3909 together with part of the road widening shown on L.P.120979 as shown on Council Plan 8914 hereby order that the part of the road shown on Council Plan No. 8914 be discontinued and sold by private treaty to the owners of Lot 71-74 L.P.120691 (Nos. 9-12 inclusive Tennyson Court) and lots 50-52 L.P.120691 (Nos. 11-13 inclusive Coleridge Court) subject to the owners of Lots 50 and 51 L.P.120691 agreeing to and giving effect to an easement of carriageway in favour of Lot 83 L.P.123587 over lots 50 and 51 L.P.120691".

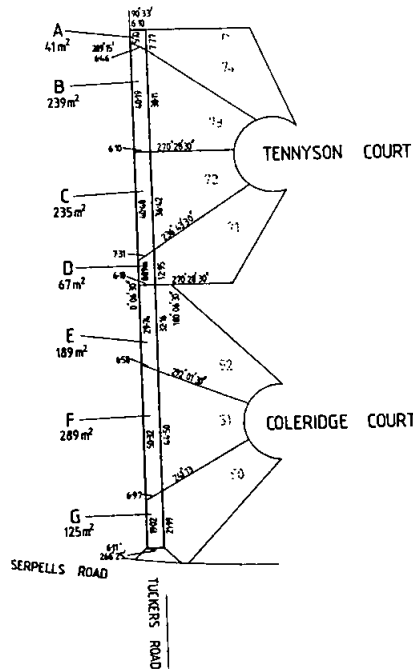
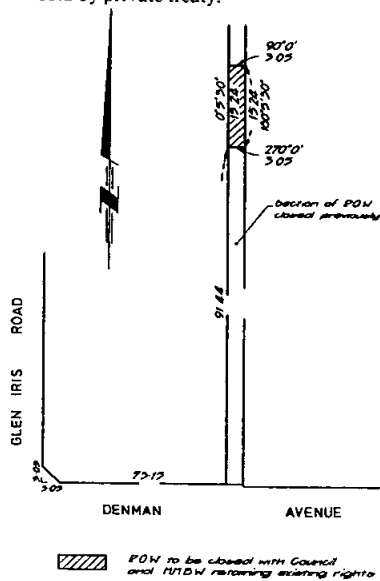

CITY OF DONCASTER AND TEMPLESTOWE
Sale Unnecessary Road—Tuckers "Road" Access Road

Pursuant to section 528 of the *Local Government Act* 1958, the Council of the City of Doncaster and Templestowe at its meeting on 3 December 1985 resolved that "Council having received a report from the Physical Resources/Electricity Services

CITY OF DONCASTER AND TEMPLESTOWE

By-Law No. 101

Building Site Requirement By-Law

A By-Law made under the provisions of the *Building Control Act* 1981 and the Victorian Building Regulations 1983 and numbered 101 for:

- (1) amending Building Site Requirement By-Law No. 98 of the City of Doncaster and Templestowe;
- (2) specifying the number of Class 1A buildings to be constructed on any one allotment.

The resolutions for passing the By-Law was agreed to by the Council of the City of Doncaster and Templestowe on 17 December 1985 and confirmed on 4 February 1986. A copy of the By-Law is open for inspection free of charge, during office hours, at the office of the Council, 699 Doncaster Road, Doncaster.

2435

G. J. MORTON, Town Clerk

CITY OF HORSHAM

Road Discontinued

Whereas section 528 (2) of the *Local Government Act* 1958 (as amended) provides that where a road (whether or not a public highway, or not being a road set out on land of the Crown) or any part thereof, is not required for public use, the Council of the Municipality in which such road is situated may, not less than one month after publishing in a newspaper generally circulating in the district, and posting to the registered proprietor (if any) of the land, and the owners and occupiers in (if any) of the land abutting or immediately to the road, notice of intention to resolve such parts shall be discontinued.

And whereas the Council of the City of Horsham having resolved to discontinue a road shown on plan of subdivision number 52024 between Howard and Queen Streets Horsham, and to sell the land contained therein by private treaty; and having on 18 December 1985, published in the *Wimmera Mail Times*, a notice advising that the Council at its meeting on 3 February, 1986, would formally resolve to close the road as described, and sell by private treaty the land contained therein; and Council having received objections to such proposal, and having dealt with such objections in accordance with section 193 (A) of the *Local Government Act*.

Does hereby order and direct, that the road shown on Plan of Subdivision No. 52024 between Howard and Queen Streets Horsham, be discontinued, and the land contained therein be vested in the municipality until such land is sold by private treaty.

2461

Form 2.1

Town and Country Planning Act 1961

CITY OF KNOX PLANNING SCHEME 1965

Notice that a Planning Scheme has been prepared and is Available for Inspection

Amendment No. 278, 1985

Notice is hereby given that the Council of the City of Knox in pursuance of its powers under the *Town and Country Planning Act* 1961, has prepared a planning scheme for the purpose of—

- (i) rezoning land on the west side of Stud Road, Wantirna South, 50 metres south of Burwood Highway, being part Lot 2 and Lot 3 on LP.8723, from Rural "A" and part Stream Zone to Commercial General;
- (ii) restricting the uses/development of the subject land to Office, Restaurant, Building and Works ancillary to these uses.

The proposed zoning will consolidate the zoning of the area and permit restricted land uses which are consistent with and complementary to the existing commercial developments in Stud Road.

A copy of the scheme has been deposited at the Office of the City of Knox, Civic Centre, 511 Burwood Highway, Knoxfield, and at the Office of the Ministry for Planning and Environment, Olderfleet Buildings, 477 Collins Street, Melbourne, and will be available for inspection during office hours by any person free of charge.

Any persons affected by the planning scheme are required to set forth in writing any submissions they may wish to make with respect to the Scheme, addressed to the Town Clerk, City of Knox, Civic Centre, 511 Burwood Highway, Knoxfield, by 23 May 1986 and to state whether they wish to be heard in respect of their submissions.

Dated 17 April 1986

2462

T. J. NEVILLE, Town Clerk

CITY OF MALVERN

Notice of Proposal to Change the Basis on which Rates may be Levied from Site Value to Net Annual Value

Notice is hereby given that the Council of the City of Malvern has, by resolution at a Special Meeting held on 11 March 1986 resolved to adopt a proposal to change the basis on which rates may be levied from Site Value to Net Annual Value as from 1 October 1986 in accordance with the provisions of the *Local Government Act* 1958 (as amended). A valuation and statement in accordance with section 316 (7) of the *Local Government Act* is open for inspection at the Council Offices, Cnr. Glenferrie Road and High Street, during office hours free of charge.

Ratepayers who do not agree with the proposed change may demand that the proposal be submitted to a poll. Such a demand may be made by one-tenth of the voters in the municipality by writing under their hands addressed to the Mayor or the undersigned and delivered at the office of the Council within one month after the date of publication of this notice. If there is no such demand for a poll the Council will proceed to implement the N.A.V. rating system as from the commencement of the 1986-87 rating year.

23 April, 1986

2437 P. A. BIRRELL, Town Clerk/City Manager

Local Government Act 1958

CITY OF WANGARATTA

Notice is hereby given, as required by section 656LA of the *Local Government Act 1958*, that the Council of the City of Wangaratta intends to borrow the sum of \$54 000, secured against a drainage rate made pursuant to section 656 of that Act.

The borrowing is to be applied to the part-construction cost of an approved Flood Mitigation Scheme.

Dated 17 April 1986

2463 J. W. ELWARD, Town Clerk

Form 2.1

Town and Country Planning Act 1961
TOWN OF BAIRNSDALE PLANNING
SCHEME

Notice that a Planning Scheme has been Prepared and is Available for Inspection

Amendment No. 63

Notice is hereby given that the Town of Bairnsdale Council in pursuance of its powers under the *Town and Country Planning Act 1961* has prepared a Scheme for the following land:

Lot 190, LP 2535, Lucknow Street, Bairnsdale.

A copy of the scheme has been deposited at the Town Offices, 8 Pearson Street, Bairnsdale; the Regional Planning Office, Ministry for Planning and Environment, 71 Hotham Street, Traralgon; and at the office of the Ministry for Planning and Environment, The Olderfleet Buildings, 477 Collins Street, Melbourne and will be open for inspection during office hours by any person free of charge.

Any persons affected by the scheme are required to set forth in writing any submission they may wish to make with respect to the scheme to the Town Clerk, Town of Bairnsdale, P.O. Box 485, Bairnsdale, Vic. 3875, by 24 May 1986 and state whether they wish to be heard in respect of their submission.

Dated 15 April 1986

2464 G. G. McWHINNEY, Town Clerk

Town and Country Planning Act 1961

SHIRE OF AVON—INTERIM
DEVELOPMENT ORDER 1979

Notice that an Amendment has been Prepared and is Available for Inspection

Amendment No. 10

Notice is hereby given that the Shire of Avon, in pursuance of its powers under the *Town and Country Planning Act 1961*, has prepared an amendment to rezone Crown allotment 104, section 1, Parish of Sale, from Irrigation zone to Rural Residential zone.

A copy of the amendment has been deposited at the office of the Shire of Avon, Tyers Street, Stratford and at the office of the Ministry for Planning and Environment, Olderfleet Buildings, 477 Collins Street, Melbourne and will be open for inspection during office hours, by any person, free of charge.

Any persons affected by the amendment are required to set forth in writing any submission they may wish to make with respect to the amendment, addressed to the Shire Secretary, by 26 May 1986 and state whether they wish to be heard in respect of their submission.

2439 G. W. BRAYSHAW, Shire Secretary

Form 2.1

Town and Country Planning Act 1961
GISBORNE SHIRE PLANNING SCHEME

Notice that an Amendment has been Prepared and is Available for Inspection

Amendment No. 19

Notice is hereby given that the Shire of Gisborne in pursuance of its powers under the *Town and Country Planning Act 1961* has prepared an amendment for the following area being No. 271, Lot 9 L.P.57590 Mount Macedon Road (known as "Glencairn"), Mount Macedon, to allow the replacement of the main homestead, destroyed in Ash Wednesday bushfire.

A copy of the amendment has been deposited at the Shire of Gisborne, Robertson Street, Gisborne and at the office of the Ministry for Planning and Environment (Plan Inspection Section), Ground Floor, The Olderfleet Buildings, 477 Collins Street, Melbourne, and will be open for inspection during office hours by any person free of charge.

Any persons affected by the amendment are required to set forth in writing any submission they may wish to make with respect to the amendment addressed to Shire Secretary, Shire of Gisborne, P.O. Box 63, Gisborne, by 23 May 1986 and state whether you wish to be heard in respect of your submission.

2438 W. R. ELLIS, Shire Engineer

SHIRE OF KILMORE

Prosecuting Officer

Notice is hereby given that the Shire of Kilmore did on 2 April 1986, appoint Sergeant John Brian Curley 12098, as Prosecuting Officer for the Shire in lieu of Senior Constable Warren Brydon Opie 16679.

2467 D. A. ANDERSON, Acting Shire Secretary

SHIRE OF KILMORE

By-law No. 32

Motorised Vehicles on Council Reserves

Notice is hereby given that the Council of the Shire of Kilmore has made a By-law No. 32 under the provisions of section 197 of the Local Government Act for the purpose of controlling the use for recreation purposes of motorised vehicles on Council owned or managed Reserves within the Shire of Kilmore.

Resolution for passing this By-law was made by Council at a meeting on 5 February 1986 and confirmed at a meeting on 5 March 1986.

A copy of the By-law has been deposited at the office of the Council, Sydney Street, Kilmore and is open for inspection free of charge during office hours.

DAVID ANDERSON

2465 Acting Shire Secretary

SHIRE OF KILMORE

By-law No. 33

Keeping of Dogs

Notice is hereby given that the Council of the Shire of Kilmore has made a By-law No. 33 under the provisions of section 197 of the Local Government Act for the purpose of controlling the keeping of dogs in populous and residential areas within the Shire of Kilmore.

Resolution for passing this By-law was made by Council at a meeting on 5 February 1986 and confirmed at a meeting on 5 March 1986.

A copy of the By-law has been deposited at the office of the Council, Sydney Street, Kilmore and is open for inspection free of charge during office hours.

DAVID ANDERSON

2466 Acting Shire Secretary

SHIRE OF NARRACAN

Whereas the Council of the Shire of Narracan deems it expedient to exercise its power of taking compulsorily the land described in the Schedule at the foot hereof for municipal purposes.

And whereas the Council has caused to be prepared a map and papers setting out the general description of the work or undertaking for which

the land proposed to be taken is to be used, the description of the land proposed to be taken and the names of the owners or reputed owners lessees or reputed lessees mortgagees and occupiers of this land so far as known to or can be ascertained by the Council.

And whereas the said maps and other papers are deposited at the Office of the said Council at its Municipal Offices, Princes Highway, Trafalgar and are and shall be open for inspection by all persons interested at all reasonable times for the space of forty clear days after the publication of this Notice in the *Government Gazette*. Notice is hereby given to all persons affected by the proposed taking of the said land that they may by notice set forth in writing addressed to the Council or the Municipal Clerk state all objections which they may have to the taking of the said land within the said forty clear days.

And take further notice that at the next ordinary meeting of the Council after the expiration of the said period of forty days any person affected by the proposed taking of the said land or his agent who has set forth in writing within the specified time his or her objection to the taking of the said land may appear before the Council.

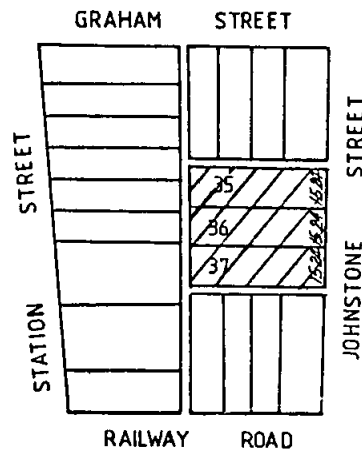

Schedule Above Referred To

Compulsory acquisition of all that piece of land situate Johnstone Street, Thorpdale being Lot 35 on Plan of Subdivision No. 2393 in the Parish of Moe more particularly described in Certificate of Title Volume 4468 Folio 414.

Schedule Above Referred To

Compulsory acquisition of all that piece of land situate Johnstone Street, Thorpdale being Lot 36 on Plan of Subdivision No. 2393 in the Parish of Moe more particularly described in Certificate of Title Volume 2447 Folio 393.

Schedule Above Referred To

Compulsory acquisition of all that piece of land situate Johnstone Street, Thorpdale being Lot 37 on Plan of Subdivision No. 2393 in the Parish of Moe more particularly described in Certificate of Title Volume 2345 Folio 943.

Dated 14 April 1986

2440 DENNIS STEVENS, Municipal Clerk.

SHIRE OF STAWELL

Notice of Intention to Take Land Compulsorily

Whereas the Council of the Shire of Stawell has deemed it expedient to exercise its powers of taking land compulsorily in accordance with the provisions of section 513 of the *Local Government Act 1958* (as amended) notice is hereby given as follows:

1. The Council intends to acquire all that land being part of Crown Allotment 6, section 6, Township and Parish of Stawell being the land described in Memorial Book 600, No. 59 and located in Leslie Street Stawell.

2. The Council has caused to be prepared maps and other papers describing the proposed work or undertaking and the description of the land proposed to be taken together with the names of the owners or reputed owners, lessees or reputed lessees, mortgagees and occupiers of such land so far as those persons are known to or can be ascertained by the Council.

3. Such maps and other papers have been approved by the Council and are deposited at the Shire Offices, Longfield Street, Stawell, where they are and will remain open for inspection by all persons interested during office hours for a period of forty (40) clear days after publication of this Notice in the *Government Gazette*.

4. All persons affected by the proposed taking of the land are hereby called upon to set forth in writing addressed to the Council or the Shire Secretary of the Shire of Stawell, Shire Offices, Stawell, 3380, within 40 clear days from the publication of this notice in the *Government Gazette*, all objections which they may have to the taking of the said land.

By Order of the Council,

2468 V. C. NIELSEN, Shire Secretary

SHIRE OF STAWELL

Notice of Intention to Take Land Compulsorily

Whereas the Council of the Shire of Stawell has deemed it expedient to exercise its powers of taking land compulsorily in accordance with the provisions of section 513 of the *Local Government Act 1958* (as amended) notice is hereby given as follows:

1. The Council intends to acquire all that land being part of Crown Allotment 7, section 5, Township and Parish of Stawell being the land described in Certificate of Title Volume 9488 Folio 964 and located at 21 Leslie Street Stawell.

2. The Council has caused to be prepared maps and other papers describing the proposed work or undertaking and the description of the land proposed to be taken together with the names of the owners or reputed owners, lessees or reputed lessees, mortgagees and occupiers of such land so far as those persons are known to or can be ascertained by the Council.

3. Such maps and other papers have been approved by the Council and are deposited at the Shire Offices, Longfield Street, Stawell, where they are and will remain open for inspection by all persons interested during office hours for a period of forty (40) clear days after publication of this Notice in the *Government Gazette*.

4. All persons affected by the proposed taking of the land are hereby called upon to set forth in writing addressed to the Council or the Shire Secretary of the Shire of Stawell, Shire Offices, Stawell, 3380, within 40 clear days from the publication of this notice in the *Government Gazette*, all objections which they may have to the taking of the said land.

By Order of the Council,

2469 V. C. NIELSEN, Shire Secretary

SHIRE OF TULLAROOP

Water Supply By-Law No. 7

Restricting the Use of Water in the Shire of Tullaroop Water Supply District

Notice is hereby given that the Council at a duly constituted meeting held on 9 July 1985 made the said By-Law No. 7 and this By-Law was approved by the Governor in Council on 30 July 1985.

The said By-law provides:

1. For the repeal of By-Law No. 6 (of the former Shire of Tullaroop Waterworks Trust).

2. That if in the opinion of the Authority it is necessary to reduce the consumption of water supplied by the Authority from a mainpipe or aqueduct for other than domestic purposes within the Authority district or part thereof the Authority may at any time and from time to time specify that this By-Law implementing any one stage of the stages numbered 1 to 8 herein shall come into operation in respect to the Authority district or part thereof and thereupon the area so specified shall be a specified area and the use of water so supplied within that specified area shall be subject to the period of restriction thereby brought into operation and the water so supplied shall not be used for the purposes listed in the stage thereby brought into operation.

3. That, subject to certain exemptions, the use of fixed sprinklers shall be prohibited on days of Total Fire Ban declared under the provisions of the *Country Fire Authority Act 1958*.

4. Penalties for breaches of the By-Law.

A copy of the By-Law (No. 7) is open for inspection free of charge at the Shire Office, Maryborough, during normal office hours.

2470 BRIAN F. O'CONNOR, Shire Secretary

SHIRE OF TULLAROOP

Notice of Intention to Acquire Land Compulsorily

Whereas the Council of the Shire of Tullaroop deems it expedient to exercise its power of taking compulsorily the land described in the Schedule hereto for the purpose of extension to a public road and whereas the Council has caused to be prepared a map and other papers setting out the general description of the work or undertaking for which the land proposed to be taken is to be used, the description of the lands proposed to be taken and the names of the owners or reputed owners, lessees, mortgagees and occupiers of that land so far as those names are known or can be ascertained by the Council and whereas the said plan and other papers are deposited at the office of the said Council at Neill Street, Maryborough and are and shall be open for inspection by all persons interested at all reasonable hours for the space of forty (40) clear days after the publication of this notice in the *Government Gazette*.

Now notice is hereby given to all persons affected by the proposed taking of the land to set forth, in writing addressed to the Council or the Shire Secretary within forty (40) clear days of the publication of this notice in the *Government Gazette* all objections which they may have to the taking of the said land.

The Schedule Hereinbefore Referred to

All that piece of land being Crown Allotments 1, 1A, 2A, 3, 4, 4A, 7A, 8, and 8A, section 3 Parish of Bet Bet, County of Talbot.

Dated 17 April 1986.

2471 BRIAN F. O'CONNOR, Shire Secretary

SHIRE OF UPPER YARRA

Whereas the Council of the Shire of Upper Yarra deems it expedient to exercise its powers of taking compulsorily the land delineated and hatched on the map at the foot hereof for the work or undertaking of a Community Centre.

And whereas the Council has caused to be prepared maps and other papers setting out the general description of the work or undertaking for which the land proposed to be taken is to be used the description of the land proposed to be taken and the names of the owners or reputed owners, lessees or reputed lessees, mortgagees and occupiers of that land so far as those names are known to or can be ascertained by the Council. And whereas the said maps and other papers are deposited at the office of the said Council at Yarra Junction and are

and shall be open for inspection by all persons interested at all reasonable hours for the space of forty clear days after the publication of this notice in the *Government Gazette*.

Now notice is hereby given to all persons affected by the proposed taking of the said land to set forth in writing addressed to the Council or Shire Secretary within forty clear days of the publication of this notice in the *Government Gazette* all objections which they may have to the taking of the said land.

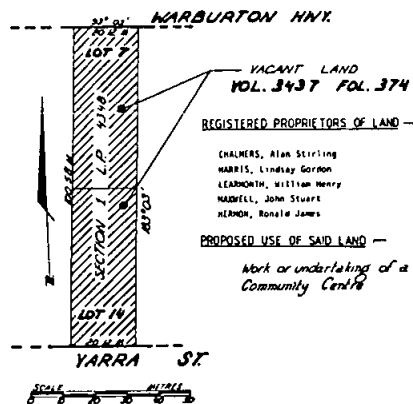

Dated 16 April 1986

By Order the Council.

J. C. CHILD, Shire President

2441

A. J. HUBBAR, Shire Secretary

GEELONG AND DISTRICT WATER BOARD

Pursuant to section 60 of the *Geelong Waterworks and Sewerage Act 1958* (No. 6263) the Board has prepared plans to indicate the particulars of sewers and underground works, the construction of which the Board intends to begin at a date not less than one month after publication of the notices, in or adjacent to the following locality within the Drainage Area.

St Albans Stud Estate, Whittington—Shire of Bellarine.

Strathmore Drive, Kenvarra Crescent, Jan Juc—Shire of Barrabool.

Notice is hereby given that the plans indicated are open for public inspection at the Board's Offices, 61-67 Ryrie Street, Geelong between the hours of 8.10 a.m. and 5.00 p.m. from Monday to Friday (public holidays excepted) by the owners or occupiers of land or premises within the Drainage Area.

2472

R. A. JORDAN, Secretary

MIRBOO WATER BOARD

The abovementioned Water Board having made provision for carrying off the sewage from each and every property which or any part of which is within the Sewerage Area hereinafter described doth hereby declare that on and after 1 March 1986 each and every property which or any part of which is within the said Sewerage Area shall be deemed to be a sewered property within the meaning of the *Sewerage Districts Act 1958*.

The boundaries of the Sewerage Area are hereinafter referred to as: Area bounded by Wembridges Road, Balook Street, Wells Road, north of Grand Ridge Road West including all allotments in P/S 61804, P/S 40307, C.A. 7A P/S 53946 Eldon Court, Mirboo North Bowling Club, High School, State School, Castle Street P/S 58908, Part C.A.7B south side of Farmer Street, Giles Street including C.A. 26A, 26B Part 41A, Part 41B, Part 42A, Part 42B, north and east Grand Ridge East C.P.105649 Part C.A. 37 including Grogan Court P/S. Lot 1 of P/S east side of Murray Street to all Lots in P/S 137576 Baromi Road to Lot 16 P/S 1374 north to Forest Way including C.A. 3 section B south side of Forest Way to Murray Street Ingliss Avenue, Thorpdale Road including C.A. 2, 3 and 5 of 7 of section 4A, C.A. 4 section 8, C.A. 3 and 4 section 9.

By order of the said Water Board

C. P. FOSTER, Chairman

J. M. IRVING, Secretary

2442

VICTORIA**Act 391—First Schedule**

Whereas by virtue of the powers conferred by the Act of the Parliament of Victoria numbered 391 the Governor on 21 February in the year 1870 allowed an application for leave to dispose of the land described in the said allowance: Now therefore I Douglas Victor Morey head or authorized representative of the denomination known as Presbyterian Church of Victoria with the consent of Presbyterian Church of Victoria Trusts Corporation trustees of the said land and, being the person or persons entitled to minister in or occupy a building or buildings upon the said land do hereby apply to the Governor of the State of Victoria to amend or vary the said allowance in manner hereinafter mentioned: And I certify—That the only trustees of the said land resident in Victoria are the Presbyterian Church of Victoria Trusts Corporation. That the only buildings upon the said land are a church building erected in 1859 and that there are no such persons entitled to minister in or occupy the same.

Signature of head or authorized representative—
D. V. Morey.

We consent to this application—

The common seal of the Presbyterian Church

of Victoria Trusts Corporation was hereto affixed in the presence of—

E. R. PEARSONS, Trustee

ROBERT HANNA, Trustee

D. W. STEER, Office Manager

of the Presbyterian Church of Victoria

Attested by Brian D. Bayston, Law Agent

Existing Statement of Trusts

Description of Land—All that piece of land being 1870 Crown Reserve of 6057 square metres, Township of Kalkallo, Parish of Kalkallo, County of Bourke being Crown Allotment 11 section 36. Commencing at the south-eastern angle of Crown Allotment 2 Section 36 bounded thence by that allotment bearing 6 deg. 01 min. 51-01 metres, by Crown Allotment 1 bearing 6 deg. 27 min. 49-72 metres, by Cameron Street bearing 96 deg. 44 min. 80-47 metres by Crown Allotment 7 bearing 186 deg. 10 min. 20 sec. 66-53 metres by lines bearing 276 deg. 44 min. 60-35 metres and 186 deg. 10 min. 20 sec. 34-20 metres and thence by Yaldwin Street bearing 276 deg. 44 sec. 20-23 metres to the point of commencement.

Names of Trustees—The Presbyterian Church of Victoria Trusts Corporation.

Powers of Dispositions—*Presbyterian Trusts Act 1890* as amended by the *Presbyterian Trusts (Common Fund) Act 1965* and *Presbyterian Church of Australia Act 1971*.

Purposes to which Proceeds of Disposition are to be applied—*Presbyterian Church of Victoria. 2473*

VICTORIA**Act 391—First Schedule**

I, Alexander Robert Gillespie, head or authorized representative of the denomination known as The Uniting Church in Australia with the consent of The Uniting Church in Australia Property Trust (Victoria) trustees of the said land described in the subjoined Statement of Trusts and of Ross Everard being the person or persons entitled to minister in or occupy a building or buildings upon the said land do hereby apply to the Governor of the State of Victoria for leave to dispose of the said land by the means and for the purposes mentioned in the said Statement of Trusts: And I certify—

That the only trustees of the said land resident in Victoria are The Uniting Church in Australia Property Trust (Victoria).

That the only buildings upon the said land are—Church and Manse.

And that the only persons entitled to minister in or occupy the same are the above-named Ross Everard and that the said land was permanently reserved by Order of Council on 29 December 1869.

Signed by the said Alexander Robert Gillespie

We consent to this application—

The common seal of The Uniting Church in Australia Property Trust (Victoria) was hereto affixed in accordance with a Resolution passed at a meeting of the members of the Trust in the presence of—

(SEAL) J. A. MITCHELL, Member
A. R. GILLESPIE, Member

Signed by the said Ross Everard

Existing Statement of Trusts

Description of Land—6436 square metres, Township of Wallan, Parish of Wallan Wallan, County of Bourke being Crown Allotment 15, section 3. Commencing at the north-eastern angle of Crown Allotment 14, section 3; bounded thence by that allotment bearing 264°35' 100.52 metres; by Stanley Street bearing 354°35' 67.99 metres; by Watson Street bearing 89°07' 100.91 metres; and thence by Wellington Street bearing 174°39' 60.02 metres to the point of commencement.

Name of Trustees—The Uniting Church in Australia Property Trust (Victoria).

Powers of Disposition—Such powers of disposition including the powers to mortgage, sell, lease, exchange and transfer lands vested in The Uniting Church in Australia Property Trust (Victoria) as are given to the said trust by *The Uniting Church in Australia Act 1977* (Vic.).

Purposes to which Proceeds of Disposition are to be applied—The proceeds of any sale of real estate shall be applied so far as the proceeds will extend in the following order:

- (a) In the discharge of any encumbrances and liabilities whether personal or otherwise lawfully created or contracted in the due execution of the trusts of these Regulations or such of them or such part thereof respectively as it may be found necessary or expedient so to discharge;
- (b) in the fulfilment of the conditions (if any) imposed by the Synod when consenting to such sale;
- (c) towards any one or more of the objects hereinafter mentioned—
 - (i) promoting the mission of the Church;
 - (ii) assisting or increasing the funds of any other committee or instrumentality of the Church;
 - (iii) erecting a new church building, church hall, residence or other building on any site vested in the Church;
 - (iv) carrying out improvements and enlargements to any such existing buildings;
 - (v) purchasing land as a site for a church building, church hall, residence or other building to be under the control of the committee of Parish Council concerned or any other instrumentality of the Church;

(vi) contributing to the funds, objects or charities under the control or direction of the Presbytery, Synod or the Assembly;

(vii) such other purposes as the Synod may approve. 2446

VICTORIA

Act 391—First Schedule

I, Alexander Robert Gillespie head or authorized representative of the denomination known as The Uniting Church in Australia with the consent of The Uniting Church in Australia Property Trust (Victoria) trustees of the land described in the subjoined statement of trusts, and of Rev. D. Bruce McKay being the person entitled to minister in or occupy a building or buildings upon the said land, hereby apply to the Governor of the State of Victoria for leave to dispose of the said land by the means and for the purposes mentioned in the said statement of trusts, and I hereby certify that the said land was permanently reserved by Order in Council on 9 December 1872, for the purpose of Presbyterian Church that the only trustees of the said land resident in the State of Victoria are The Uniting Church in Australia Property Trust (Victoria).

That the only buildings upon the said land are Brick Church and that the only person entitled to minister in or occupy the same is the above-named Rev. D. Bruce McKay.

Signed by the said A. R. Gillespie.

We consent to this application—

The common seal of The Uniting Church in Australia Property Trust (Victoria) was hereunto affixed in pursuance of a Resolution passed at a meeting of the Members of the Trust in the presence of—

(SEAL) A. R. GILLESPIE, Member
G. McANALLEY, Member

Signed by the said Rev. D. Bruce McKay.

Statement of Trusts

Description of Land—Site for Presbyterian Church purposes permanently reserved by Order in Council 9 December 1872, 8094 square metres, Township of Newstead, Parish of Strangways, County of Talbot being Crown Allotment 7 section 9A. Commencing at the most southern angle of Crown Allotment 6 section 9A; bounded thence by that allotment bearing 49° 28' 100.58 metres; by Church Street bearing 139° 28' 80.47 metres; by a road bearing 229° 28' 100.58 metres; and thence by Racecourse Road bearing 319° 28' 80.47 metres to the point of commencement.

Names of Trustees—The Uniting Church in Australia Property Trust (Victoria).

Powers of Disposition—Such powers of disposition, including powers of sale, lease or mortgage as are given to the Trust by the Uniting Church in Australia Property Trust (Victoria) Act Number 9021 of 1977.

Purposes to which Proceeds of Disposition are to be applied—To such Uniting Church in Australia purposes as shall be approved by the Committee of the Victorian Synod of the Uniting Church in Australia. 2489

VICTORIA

Act 391—First Schedule

I, Alexander Robert Gillespie, head or authorized representative of the denomination known as the Uniting Church in Australia with the consent of the Uniting Church in Australia Property Trust (Victoria) trustees of the said land and of the Rev. Ross Andrew Gillard of 61 South Street, Beaufort being the person or persons entitled to minister in or occupy a building or buildings upon the said land do hereby apply to the Governor of the State of Victoria to amend or vary the said allowance in manner hereinafter mentioned: And I certify—

That the only trustees of the said land resident in Victoria are The Uniting Church in Australia Property Trust (Victoria).

That the only buildings upon the said land are Nil—Vacant land.

And that the only persons entitled to minister in or occupy the same is the above-named Ross Andrew Gillard and that the said land was temporarily reserved by Order in Council of 24 July 1865.

Signed by the said Alexander Robert Gillespie

Signed by the said Ross Andrew Gillard

We consent to this application—

The common seal of the Uniting Church in Australia Property Trust (Victoria) was hereunto affixed pursuant to a Resolution passed at a meeting of the Members of the Trust in the presence of—

A. R. GILLESPIE, Member

(SEAL) G. McANALLEY, Member

Existing Statement of Trusts

Description of Land—Commencing at the south-eastern angle of Crown allotment 1 section 1 bounded thence by that allotment bearing 0°0' 100-58 metres by allotment 2 bearing 90°0' 80-47 metres by a road bearing 180°0' 50-29 metres and thence by a road bearing 270°0' 40-23 metres to the point of commencement. Being 6070 square metres Parish of Windemere County of Grenville being Crown Allotment 1A Section 1.

Names of Trustees—The Uniting Church in Australia Property Trust (Victoria).

Powers of Disposition—Such powers of disposition including the powers to mortgage, sell, lease exchange and transfer lands vested in The Uniting Church in Australia Property Trust (Victoria) as are given to the said Trust by *The Uniting Church in Australia Act 1977* (Vic.).

Purposes to which Proceeds Disposition are to be applied— The proceeds of any sale of real estate shall be applied so far as the proceeds will extend in the following order:

- (a) In the discharge of any encumbrances and liabilities whether personal or otherwise lawfully created or contracted in the due execution of the trusts of the Regulations of the Uniting Church in Australia or such of them or such part thereof respectively as it may be found necessary or expedient so to discharge;
- (b) In the fulfilment of the conditions (if any) imposed by the Synod when consenting to such sale;
- (c) Towards any one or more of the objects hereinafter mentioned—
 - (i) promoting the mission of the Church;
 - (ii) assisting or increasing the funds of any other committee or instrumentality of the Church;
 - (iii) erecting a new church building, church hall, residence or other building on any site vested in the Church;
 - (iv) carrying out improvements and enlargements to such existing buildings;
 - (v) purchasing land as a site for a church building, church hall, residence or other building to be under the control of the committee of Parish Council concerned or any other instrumentality of the Church;
 - (vi) contributing to the funds, objects or charities under the control or direction of the Presbytery, Synod or the Assembly;
 - (vii) such other purposes as the Synod may approve. 2423

VICTORIA

Act 391—First Schedule

I, Alexander Robert Gillespie, head or authorized representative of the denomination known as the Uniting Church in Australia with the consent of the Uniting Church in Australia Property Trust (Victoria) trustees of the said land and of the Rev. Ross Andrew Gillard of 61 South Street, Beaufort being the person or persons entitled to minister in or occupy a building or buildings upon the said land do hereby apply to the Governor of the State of Victoria to amend or vary the said allowance in manner hereinafter mentioned: And I certify—

That the only trustees of the said land resident in Victoria are: The Uniting Church in Australia Property Trust (Victoria).

That the only building upon the said land are Nil—Vacant land.

And that the only person entitled to minister in or occupy the same is the above-named Ross Andrew Gillard and that the said land was temporarily reserved by Order in Council of 8 May 1865.

Signed by the said Alexander Robert Gillespie.
We consent to this application—

The common seal of The Uniting Church in Australia Property Trust (Victoria) was hereunto affixed pursuant to a Resolution passed at a Meeting of the Members of the Trust in the presence of—

A. R. GILLESPIE, Member
(SEAL) G. McANALLEY, Member
Signed by the said Ross Andrew Gillard.

Existing Statement of Trusts

Description of Land—2023 square metres, Parish of Windermere, County of Grenville being Crown Allotment 1B, Section 1. Commencing at a point bearing 90°00' 40-23 metres from the south eastern angle of Crown Allotment 1 Section 1; bounded thence by lines bearing 0°00' 50-29 metres 90°00' 40-23 metres; and thence by roads bearing 180°00' 50-29 metres and 270°00' 40-23 metres to the point of commencement

Names of Trustees—The Uniting Church in Australia Property Trust (Victoria).

Powers of Disposition—Such powers of disposition including the powers to mortgage sell lease exchange and transfer land vested in The Uniting Church in Australia Property Trust (Victoria) as are given to the said Trust by *The Uniting Church in Australia Act 1977* (Vic.).

Purposes to which Proceeds Disposition are to be applied—The proceeds of any sale of real estate shall be applied so far as the proceeds will extend in the following order:

- (a) In the discharge of any encumbrances and liabilities whether personal or otherwise lawfully created or contracted in the due execution of the trusts of the Regulations of the Uniting Church in Australia or such of them or such part thereof respectively as it may be found necessary or expedient so to discharge;
- (b) in the fulfilment of the conditions (if any) imposed by the Synod when consenting to such sale;
- (c) towards any one or more of the objects hereinafter mentioned—
 - (i) promoting the mission of the Church;
 - (ii) assisting or increasing the funds of any other committee or instrumentality of the Church;
 - (iii) erecting a new church building, church hall, residence or other building on any site vested in the Church;
 - (iv) carrying out improvements and enlargements to such existing buildings;

- (v) purchasing land as a site for a church building, church hall, residence or other building to be under the control of the committee of Parish Council concerned or any other instrumentality of the Church;
- (vi) contributing to the funds, objects or charities under the control or direction of the Presbytery, Synod or the Assembly;
- (vii) such other purposes as the Synod may approve. 2424

The partnership of Ann McMillian Bailey and Sandra Jane Bailey trading as Patina Art was dissolved on 18 December 1985. Ann McMillian Bailey continues to trade under the name Patina Art at 20 Bluff Road, Black Rock. 2445

Notice is hereby given that the partnership heretofore subsisting between Helen Anne Duffy and Geoffrey Robert Bruce Currey carrying on business as Publishers at 319 Swan Street, Richmond in the State of Victoria under the firm name of "Elm Grove Press" has been dissolved as from 1 March 1986.

Dated 11 April 1986

HELEN ANNE DUFFY
2474 GEOFFREY ROBERT BRUCE CURREY

Take notice that the partnership existing between Hugo Nation Ottaway of 11 Sycamore Street, Camberwell and Thomas Max Ottaway of 134 Athol Street, Moonee Ponds which conducted the business known as Insail at 442 Chapel Street, South Yarra was dissolved on 25 February 1986.

GEOFFREY V. SHIFF, solicitor, of 416 Collins Street, Melbourne. 3000. Ph. 602 1888 2475

WESTMOT PROPERTIES PTY. LTD.

(in Voluntary Liquidation)
Final Meeting and Dissolution

Accounts of the winding up will be presented at the meeting to be held on 30 May 1986 at 2.00 p.m., 99 Brown Street, Hamilton 3300.

2444 JOHN E. RILEY, Liquidator

AUSTRALIA FELIX PTY. LTD.

(in Voluntary Liquidation)
Final Meeting and Dissolution

Accounts of the winding up will be presented at the meeting to be held on 30 May 1986 at 1.30 p.m., 99 Brown Street, Hamilton 3300.

2443 JOHN E. RILEY, Liquidator

Unclaimed Moneys Act 1962

Register of Unclaimed Moneys held by the—

<i>Name of Owner on Books and Last Known Address</i>	<i>Total Amount Due to Owner</i>	<i>Description of Unclaimed Money</i>	<i>Date when Amount first became Payable</i>
\$			
ESANDA LIMITED			
Finke, Frederick W. and Aydrey M., 76 Truganini Rd, Carnegie	525.00	Interest	19.11.81
Taylor, Valma Lesley, 15 Kawina Crt, Clifton Springs, W.A.	108.50	"	22.11.84
De Niese, Ivan Peter, 7/54 Kenilworth St, Bayswater, W.A.	42.00	"	26.2.85
Buddy Squirrel Australia Pty. Ltd., P.O. Box 66, Mansfield	16.50	"	15.5.82
Chisholm, Keith Lyle, trustee for Catherine Florence Chisholm, 62 Pye St, Swan Hill	13.75	"	15.1.82
Chisholm, Keith Lyle, trustee for Lyle Adrian Chisholm, 62 Pye St, Swan Hill	24.06	"	"
Korumburra Football Club, Fourths Club, care of Mr J. R. George, 1A Richards St, Korumburra	13.58	"	8.1.82
Lyons, Mark Lincoln, trustee for Joanna Claire Lyons, Benacre, Longwood	11.75	"	15.3.82
Mackin, Lesley Joan, Fish Creek	18.75	"	12.4.82
Mylan, Anthony John, Ascot Vale Produce, 536 Racecourse Rd, Flemington	33.29	"	2.3.82
Woodward, Glenn Daryl, Private Bag, Brim	160.95	"	22.3.82
Ahern, Terrance Gerald (estate of), care of Birch Ross and Barlow, P.O. Box 41, Leongatha	325.00	"	15.2.85
Armstrong, Lawrence John and Judith Eleanor, 30 Warrigal Rd, Surrey Hills	86.28	"	15.12.84
Aughterson, Claire Victoria (estate of), care of D. M. Aughterson, 2 Wye Crt, Ferntree Gully	40.00	"	15.3.84
Austin, Darren James and Amanda Leigh, care of L. D. Warren, 5 Sharpley Ave, Stawell	28.00	"	14.3.84
Bayliss, Dennis John (estate of), care of Macpherson and Kelly, 14 Balmoral Ave, Springvale	13.56	"	3.5.84
Brown, Cecile Mary (estate of), care of ANZ Executors Trustee Company Limited, 94 Queen St, Melbourne	28.60	"	19.1.85
Bulleid, Margaret Ruth, 4 Margaret Crt, Millgrove	39.11	"	15.6.84
Byrne, Belinda Elizabeth, 781 Drummond St, Carlton North	325.00	"	11.10.84
Carmichael, Robert, 109 Autumn St, Geelong	54.25	"	15.11.84
Catchment Playes, P.O. Box 205, Reservoir	14.23	"	10.2.85
Chisholm, Keith Lyle, trustee for Catherine Florence Chisholm, 62 Pye St, Swan Hill	13.75	"	15.4.84
Chisholm, Keith Lyle, trustee for Lyle Adrian Chisholm, 62 Pye St, Swan Hill	24.06	"	"
Claney, Jennifer, 4/58A Finch St, Beechworth	57.32	"	20/12/84
Conheady, Mary Agnes, P.O. Box 242, Warrnambool	153.42	"	28.8.84
Cooper, Leslie George and Downs, Dorothy Maude, Riverview, Molesworth	35.00	"	15.8.84
Cooper, Patricia Margaret, care of John Cooper, 58 Flannery Ave, Bundoora	19.94	"	4.2.85
Cuming, Elizabeth Anne, 2 Somers Ave, Malvern	110.90	"	3.6.84
Hungerforddarton, Richard, 1 Bonavista Ave, Surrey Hills	14.35	"	3.1.85
Davy, Anthony, 18 Farrer Plc, Oyster Bay, N.S.W.	201.30	"	4.1.85
Picocco, Giovanni, 58 Victoria Rd, Hawthorn	43.66	"	28.2.85
Donker, Maria, 545 Main Rd, Belgrave	52.88	"	15.2.85
Down, Geoffrey Peter, Murella RMB 2498, Port Fairy	31.25	"	5.2.85
Doyle, John Vincent, 2/376 Station St, Box Hill	35.94	"	21/9/84
Driftsome Investments Pty Ltd Superannuation Fund, 24 Balcombe Rd, Mentone	192.38	"	28.3.84

Unclaimed Moneys Act 1962

Register of Unclaimed Moneys held by the—

<i>Name of Owner on Books and Last Known Address</i>	<i>Total Amount Due to Owner</i>	<i>Description of Unclaimed Money</i>	<i>Date when Amount first became Payable</i>
\$			
ESANDA LIMITED— <i>continued</i>			
Dunoon, Peter Donald, 18 Greg St, Swan Hill	45.00	Interest	28.11.84
Finlay, Anthony, Cororooke	140.00	"	15.11.84
Fleming, Heather Kathryn, Streatham	17.25	"	15.12.84
Fraser, Albert, 26 Rennison St, Parkdale	79.50	"	15.3.84
Glasgow, Margaret Ann, Mid Branch, Bena	30.62	"	15.10.84
Glass, Jessie, care of G. D. Stevenson, 5 El-Remlen Ave, Wendouree	42.50	"	15.5.84
Goulburn Valley Lodge of St George, care of The Secretary, W. Kinmond, 27 Bradford Rd, Shepparton	32.50	"	10.2.85
Grace, Elizabeth Margaret, 620 Warrigal Rd, South Oakleigh	13.88	"	7.6.84
Greenbank, Margaret Beverly, trustee for Wendy Anne Greenbank, 2 Marilyn St, Wendouree	32.50	"	20.12.84
Greenbank, Margaret Beverly, trustee for Mark Leslie Greenbank, 2 Marilyn St, Wendouree	33.12	"	"
Greta Football Club, care of G. White, RMB 1525, Glenrowan	11.22	"	25.10.84
Hammerton, Gwenneth May, trustee for Stacey Lee Hammerton, 77 Betula Ave, Bundoora	12.56	"	15.6.84
Harding, Karen, 18 Silverdale Crt, Springvale South	14.00	"	15.5.84
Hass, Egon Joseph, 53 Johns St, Glenroy	287.50	"	6.1.85
Hemmings, Rita Michel, trustee for Linda J. Abdilla and Joanne M. Abdilla, 6 Galloway Gve, Bayswater North	32.16	"	25.10.84
Hemmings, Rita Michel, trustee for Joanne Maree Hemmings, 6 Galloway Gve, Bayswater North	80.88	"	"
Hemmings, Rita Michel, trustee for Linda Joy Abdilla, 6 Galloway Gve, Bayswater North	80.88	"	"
Hendersen, Mary Hannah, 7 Pleasant Dve, Heathmont	70.00	"	15.12.84
Herceg, Stefan, 32 Keats Ave, Kingsbury	28.21	"	22.7.84
Hintz, Shirley Janice, 36 Rattray St, Wangaratta	23.41	"	30.9.84
Hocking, Tracey Jane, 16 Perrin St, Robinvale	56.04	"	15.2.84
Ireland, Lillian Maud, 15 Pine Ave, Park Orchards	16.12	"	3.1.84
Johnstone, William Alexander (estate of), care of Public Trust Office, 168 Exhibition St, Melbourne	82.49	"	9.3.84
Jones, Annie Aurelia, 3/18 Grove St, Ballarat	65.00	"	9.7.84
Jones, Waita E., Apted, Ian F. and Larkins, Valerie E., 63 Yarra St, Geelong	10.13	"	15.7.84
Karpavicius, Kuni, trustee for Michael and Jane Karpavicius, 1 Wilga Cres, Caulfield	15.50	"	24.11.84
Kellock, Richard John and Terence Gerard, 5 Lynette Crt, Mulgrave	212.50	"	5.7.84
Kelly, Barbara Irmgard, 32 Blair St, Coburg	25.57	"	15.2.85
Keane, Beverly June, 78 Manton Rd, Clayton	46.37	"	23.9.84
Knell, Nellie Kyle, 543 Main Rd, Belgrave	50.00	"	15.6.84
Korumburra Football Club Fourths Club, care of J. R. George, 1A Richards St, Korumburra	11.12	"	8.4.84
Kuriana, Kuriana and Wei, Maria Koeilan, 5 Maldon Cres, East Doncaster	44.40	"	18.11.84
Latham, Kathleen Hazel, care of Barnett Rockman & Co., Suite 2, 1st Floor, Balmoral Centre, Frankston	60.00	"	15.3.84
Mace, Margaret Helen and Rockman, Barnett, 18 Barmah St, Mount Eliza	393.75	"	15.1.85
Mawson, Julie Mary, care of Mr Tuckfield, 42 Prospect Hill Rd, Camberwell	36.87	"	15.3.84
McCarthy Norah, P.O. Box 70, Croydon	57.45	"	19.8.84

Unclaimed Moneys Act 1962

Register of Unclaimed Moneys held by the—

<i>Name of Owner on Books and Last Known Address</i>	<i>Total Amount Due to Owner</i>	<i>Description of Unclaimed Money</i>	<i>Date when Amount first became Payable</i>
\$			
ESANDA LIMITED—continued			
McFarlane, Gladys Jean, 8 Winterton Dve, Glen Waverley	100.00	Interest	15.3.84
McLennan, Nola Valerie, trustee for Roderick John McLennan, Angmar, Mortlake	13.90	"	6.4.84
McLeish, Rodney Malcolm and Heather Dawn, Higgs Rd, Drouin	27.96	"	13.7.84
McNear, Dulcie Maud, 6/5 Landdon Ave, Wagga Wagga, N.S.W.	70.00	"	21.10.84
Mounsey, Charles Henry, 2/33 North Road, North Brighton	137.50	"	15.7.84
Moylan, Anthony John, care of Esanda Registry, 5/1 Collins St, Melbourne	114.71	"	2.3.84
Murrumbidgee Districts Junior Football Club Social Committee, 38 Oakleigh Rd, Ormond	29.34	"	2.9.84
Murray, Dorothy Jean, Trustee for Andrea Farry, 34 Nicholson St, East Brunswick	31.88	"	15.8.84
Naylor, Joan Hillary, RMB 4700, Alexandra	156.25	"	14.4.84
Nelson, Philip Craig, 2/7 Stirling St, Kew	39.38	"	15.8.84
Norbury, Catherine Ann, 32 Wood St, Nunawading	15.50	"	17.11.84
Nuske, Peter Robert, RMB 2082, Portland	11.94	"	10.8.84
O'Brien, Brendan Francis, care of Post Office, Snake Valley	24.08	"	6.2.85
Odell, Charles, 39 Arcadia Ave, The Basin	86.77	"	7.12.84
Oldaker, Barry and Patricia Anne, RSD Bullarook, via Ballarat	387.50	"	31.12.84
Oliveri, Fortunato, trustee for Rosa Oliveri, 36 Meninya St, Moama, N.S.W.	62.69	"	15.4.84
Ophthalmic Research Institute of Australia, care of ANZ Executors & Trustees, G.P.O. Box 389D, Melbourne	283.33	"	30.10.84
Patmore, John Ignatius, 9 Ingleside Cres, Glen Waverley	70.00	"	15.2.85
Pearson, Alice Elizabeth, care of Mr Ludescher, 30 Alma Rd, Camberwell	55.37	"	15.4.84
Petschel, Elfreda Marie, 54 Rippon Rd, Hamilton	65.75	"	14.2.85
Phillips, Angeil Arthur (estate of), care of Pearce & Webster, 1st Floor, 51 Queen St, Melbourne	33.75	"	13.2.85
Potton, Midas Elizabeth, 182 Candian Bay Rd, Mt Eliza	63.75	"	15.8.84
Rankin, Judith Henrietta, P.O. Box 65, Trafalgar	300.00	"	10.12.84
Redford, Sonia Muir, 54 Pleasant St, Pascoe Vale	28.56	"	26.1.85
Reidy, Ellen Elizabeth (estate of), care of Andrew Quinn & Associates, 274 Bay St, North Brighton	162.50	"	18.12.84
Roberts, Helen Bessie, 3 Staley St, Brunswick	67.50	"	11.9.84
Rose, Sarah, care of G. R. Taylor, P.O. Box 23, Doncaster East	28.19	"	9.3.84
Ross, Gladys Mary, 8 Bowley Ave, Balwyn	33.75	"	15.8.84
Rush, William Leopold (estate of), care of Rush & Failla, 144 Upper Heidelberg Rd, Ivanhoe	70.00	"	15.10.84
Sands, Debra Joy, Unit 2/1391 North Rd, Clayton	200.00	"	15.6.84
Seto, Rosie, trustee for Tracey Donna Seto, 1 Tarnock St, Vermont South	28.75	"	15.5.84
Seto, Rosio, trustee for Laura Lisa Seto, 1 Tarnock St, Vermont South	28.75	"	"
Seto, Rosie, trustee for Lance Wayne Seto, 1 Tarnock St, Vermont South	31.25	"	"
Seto, Rosie, 1 Tarnock St, Vermont South	27.12	"	12.5.84
Shadforth, Walter Robert and Evelyn Hazel, 148 High St, Cobram	86.25	"	15.12.84
Shepherd, Joan Hilary, RMB 4700 Maroondah Hwy, Alexandra	288.84	"	9.12.84
Skinner, Bertha Agnes, 245 Balaclava Rd, Caulfield	48.00	"	15.1.85
Slater, Susan June, trustee for Kyle William Slater, care of Esanda Ltd., 5/1 Collins St, Melbourne	61.25	"	15.2.85

Unclaimed Moneys Act 1962

Register of Unclaimed Moneys held by the—

<i>Name of Owner on Books and Last Known Address</i>	<i>Total Amount Due to Owner</i>	<i>Description of Unclaimed Money</i>	<i>Date when Amount first became Payable</i>
\$			
ESANDA LIMITED—continued			
Slater, Susan June, trustee for Tracey Jayne Slater, care of Esanda Ltd., 5/1 Collins St, Melbourne	61.25	Interest	15.2.85
Steel Howard John, trustee for David James Keswick Steel, 4 Beale St, Templestowe	76.23	"	15.3.84
Steel, Stanley James and Lynette Joyce, Aura Vale Rd, Menzies Creek	144.18	"	3.8.84
Sztrajt, Felix, trustee for Michelle Sztrajt, 14 Carlyle Cres, Mont Albert	52.50	"	15.4.84
Sztrajt, Victor, trustee for Tahni Sztrajt, 14 Carlyle Cres, Mont Albert	14.00	"	"
Tappy, Wesley and Joan, 19 Marianne Way, Mt Waverley	1091.33	"	4.6.84
Taylor, Allan James, trustee for Maris and Gabrielle Taylor, P.O. Box 159, Essendon	40.62	"	7.11.84
Taylor, Rose, 4/597 Dandenong Rd, Armadale	189.86	"	15.5.84
Teccombe Pty. Ltd.	35.00	"	19.10.84
Elizabeth, Anne, trustee for Danielle Fiona Thompson, P.O. Box 47 Lilydale	12.25	"	15.2.85
Timms, Leo Thomas, 5 Adeney St, Camperdown	55.00	"	28.11.84
Tintagel Investments Pty. Ltd., 54 Old Mornington Rd, Mt Eliza	11.89	"	15.6.84
Trainor, Valentine Francis, 289 Flinders Lane, Melbourne	25.70	"	26.1.85
Tuddenham, Wilfred Guy, trustee for Lynda Anne, 20 Outlook Drive, Doncaster	88.36	"	26.11.84
Tuddenham, Wilfred Guy, trustee for Sandra Dianne Tuddenham, 20 Outlook Drive, Doncaster	88.36	"	"
Turner, Alfred Brian (estate of), care of Canon Hollingworth, 15 Gore St, Fitzroy	200.00	"	"
Turner, Iris Charlotte Alice, 8 Carman Court, Ringwood	12.50	"	15.2.85
Vella, Micheal, 7/62 Halstead St, Caulfield	260.00	"	27.2.85
Vlahandreas, Tony, 210 Bridge St, Port Melbourne	113.42	"	16.2.85
Wallace, Marion Grace, trustee for J. C., J. E. and O. R. Wallace, East Brighton	12.50	"	22.8.84
Walters, Margaret Stella, Somerton Rd, Oaklands Junction	29.11	"	13.8.84
Walzak, Timothy Allin Joseph, trustee for Leonard Pearce, 273 Pascoe Vale Rd, Essendon	26.79	"	24.9.84
Wather, Norma Cathryn, 10 Dellas Ave, Templestowe	117.56	"	7.10.84
Weymouth, Lawrence, 5 Warrawee Rd, Wantirna	33.45	"	29.3.84
White, Angela Evelyn, 48 Stanley Gve, Blackburn	30.07	"	15.10.84
Wilmot, Elizabeth Grace, 44 Highett St, Richmond	88.11	"	25.7.84
Woodward, Glen Daryl, Private Bag, Brim	140.00	"	6.11.84
Yates, Edith Nellie, 1/163 Canterbury Rd, Canterbury	130.00	"	11.7.84
Edgar, Sara, 15/61 Darling St, South Yarra	22.93	"	5.12.83
Heasley, Andrew James Lyle, 21 Stratford Avenue, East Bentleigh	11.80	"	30.8.84
McKenzie, Deidre Gail, trustee for Anthony McKenzie and Monique McKenzie, care of Turnbull Bros, RMB 102, Mooroopna	14.00	"	10.11.84
Pardy, Denise, trustee for Katrina Michelle Pardy, care of 21 Karnak Rd, Ashburton	22.69	"	15.11.84
Wilson, James William, 16 Kerferd Rd, Albert Park	19.50	"	29.3.84
Mondil Projects Pty Ltd., 5 Banfield Ave, East Hawthorn	37.70	Payment	1.3.84
Tenth Cabana Pty. Ltd., 81 Wantirna Rd, Wantirna	237.28	"	6.3.84
Pollution Control Eng., 53 Kingsway, Glen Waverley	39.15	"	9.3.84
G.S.W. Automotive, 8 Mercer St, Geelong	140.68	"	13.3.84
Indonesian Management Services, 3 Bowen Cres, Melbourne	31.05	"	14.3.84
Ivan Eugene Pty. Ltd., Suite 1A, 320 Toorak Rd, South Yarra	65.69	"	"
Megna, R. E., 36 Mangan St, Tongala	246.96	"	15.3.84

Unclaimed Moneys Act 1962

Register of Unclaimed Moneys held by the—

<i>Name of Owner on Books and Last Known Address</i>	<i>Total Amount Due to Owner</i>	<i>Description of Unclaimed Money</i>	<i>Date when Amount first became Payable</i>
\$			
ESANDA LIMITED—continued			
Chamberlain, V. P., 31 Barkly St, Camperdown	19.50	Payment	16.3.84
Peter Albrecht Corp., 223 Park St, South Melbourne	65.92	"	21.3.84
T. & E. Nominees Pty. Ltd., 154 High St, Thomastown	590.32	"	28.3.84
Crysta Pools (Vic.) Pty. Ltd. 13 McKeon Rd, Mitcham	54.60	"	23.3.84
Skelton, R. W. and N. J., Back Rd, Portsea	298.12	"	4.4.84
Chamberlain, V. P., 31 Barkley St, Camperdown	19.50	"	6.4.84
Ben-Danan, J., 584 Inkerman St, Caulfield	147.85	"	11.4.84
Duff, J. D. and C. R., 121 William St, Melbourne	242.69	"	"
Ray Grounds & Co. Pty. Ltd., 549 St. Kilda Rd, Melbourne	292.69	"	12.4.84
Sorrento Quality Meats, 7 Dolphin Ave, Rye	34.22	"	16.4.84
Chamberlain, V. P., 31 Barkley St, Camperdown	19.50	"	15.5.84
Kennedy, J. N., 13/27 Patterson Rd, Moorabbin	56.67	"	18.5.85
Crazy Daves Discount Lighting, 14 Singsby Ave, Beaconsfield	42.92	"	28.5.84
Richmond Auto Electrical, 141 Dover St, Richmond	12.90	"	13.6.84
Chamberlain, V. P., 31 Barkley St, Camperdown	19.50	"	18.6.84
Stewart, R. B., Princes Highway, Cann River	193.89	"	28.6.84
Brett Michael Pty. Ltd., 23 Koornang Rd, Carnegie	117.56	"	1.6.84
Henderson, D. J., 1/14 Albert St, Corowa, N.S.W.	148.60	"	31.5.84
Spiral Jeans & Sportswear, 192 High St, Ashburton	196.32	"	13.6.84
Jewell, R. R., 36/105 Barkly St, Mordialloc	229.61	"	13.7.84
Tupp, T. G., Lot 32 Berrabin St, Scoresby	33.67	"	"
Russell, B. J., 1/34 Charles St, Traralgon	15.36	"	4.7.84
Northey, S. H., 390 Flushcombe Rd, Blacktown, N.S.W.	59.34	"	10.7.84
Noonan, M. M., 1/22 Konrad Cres, Highton	191.81	"	30.7.84
Harriage, W. J., 44 Rosslyn Ave, Seaford	107.51	"	26.7.84
Puschan, F. J. and P. D., 972 Nepean Highway, Moorabbin	136.48	"	24.7.84
Humphreys, E., Holland St, M1 Beauty	81.64	"	4.7.84
McDonell Nominees P/L, 963 North Rd, Murrumbena	49.29	"	"
Snow, K. F., 8 Joffre St, Burwood	10.78	"	11.7.84
Chamberlain, V. P., 31 Barkley St, Camperdown	19.50	"	16.7.84
Novelli, M. and D. M., 18 Oxford Dve, Thomastown	250.00	"	7.8.84
O'Callaghan, G. E. and R. J., Wallace St, Delacambe	243.30	"	13.8.84
Industrial Support Service, 32 Murray St, Elsternwick	78.75	"	30.8.84
Lenz, R. H., 45A Alexander St, Clifton Hill	144.19	"	31.8.84
Osborne, A. V., 65 Stanley St, West Melbourne	602.69	"	6.8.84
Rundolfson, Kriflair,	165.00	"	4.5.81
Unknown	87.80	"	19.6.81
Unknown	120.41	"	12.8.81
Navarro, M.	350.00	"	9.11.81
Stee, P.	185.45	"	22.2.82
Camazon, F. V.	156.16	"	10.5.82
McNamara, S.,	87.20	"	3.5.82
Unknown	42.97	"	28.5.82
Unknown	10.00	"	21.6.82
Eleventh May Lux	168.02	"	9.7.82
Wilson, C.	176.00	"	7.9.82
Unknown	27.00	"	11.10.82
Heeves, J. A.,	127.20	"	23.11.82
Unknown	116.08	"	9.12.82
Unknown	40.00	"	"
Cameron R. A. and K. A.	28.00	"	"

Unclaimed Moneys Act 1962

Register of Unclaimed Moneys held by the—

<i>Name of Owner on Books and Last Known Address</i>	<i>Total Amount Due to Owner</i>	<i>Description of Unclaimed Money</i>	<i>Date when Amount first became Payable</i>
\$			
ESANDA LIMITED—continued			
Burg, G. and L.,	147.22	Payment	..
Unknown	471.32	"	..
Unknown	100.00	"	27.7.83
Unknown	90.92	"	9.8.83
Unknown	60.00	"	..
Unknown	298.73	"	21.9.83
Unknown	129.00	"	..
Unknown	10.00	"	..
Unknown	93.00	"	..
Unknown	200.00	"	..
The Gippsland Hotel, 126 Wellington Parade, East Melbourne	195.00	"	26.9.84
Lenk, G. A. and B. J., 42 Laburnam St, Brighton	1366.45	"	13.9.84
Jacques, S. R. 32 Myrmong Cres, Ascot Vale	44.80	"	6.8.84
Campbell, B. E. and G. I., 13 Wyung Dve, Morwell	473.60	"	3.10.84
Initial Services (Southern) P/L, 2 Konando Terrace, Edwardstown, S.A.	109.23	"	2.10.84
Moorabbin Security Services, 25 Golden Ave, Chelsea	27.33	"	1.10.84
Weightmasters P/L, 195 Lennox St, Richmond	76.06	"	8.11.84
Goldsbrough, T., Lot 1 Hazelwood Rd, Hazelwood, S.A.	337.41	"	4.12.84
Montego Boutique, 398 Chapel St, South Yarra	77.04	"	17.12.84
Romar Drafting, 27 Daymar Dve, Mooroolbark	185.14	"	23.11.84
Ash, K. L. 50 Steel St, Corowa, N.S.W.	220.48	"	31.10.84
Savage, J. A. and F. J., 25 Kavanda St, Langwarrin	355.50	"	12.11.84
Fumay Pty. Ltd., 39 Gheringhap St, Geelong	213.96	"	13.11.84
Lang, F. S., 103 Seymour St, Ballarat	169.27	"	17.12.84
Albury Regent Partnership, 500 Collins St, Melbourne	151.20	"	10.1.85
Mondaley Concrete, P.O. Box 498, Noosa Heads, Qld.	195.10	"	28.3.84
Icely, P., 313 Park St, Hawthorn	31.02	"	10.12.84
Peters, M. A., 2/71 Clarence St, Elsternwick	12.71	"	7.11.84
Zdravkovski, D. and V., 19 Mackey St, Lalor	152.44	"	17.1.85
Shakespeare, P. M., 464 The Esplanade, Mt Martha	58.98	"	31.1.85
Southside Dental Ceramics, 19 Bank St, South Melbourne	159.53	"	30.1.85
2293			
CADBURY SCHWEPPE AUSTRALIA LIMITED			
Adams, Robert C., care of Price Waterhouse, 447 Collins St, Melbourne	12.97	Dividend	10.10.84
Atkin, Colin, 9 Gezvieth St, Pascoe Vale South	10.50	"	"
Barratt, Daphne, 91 Yarra St, Geelong	97.34	"	"
Berkman, Cecil E., 84 Beresford Rd, Rose Bay, N.S.W.	70.88	"	"
Borzell, Adrian, P.O. Box 443, Potts Point, N.S.W.	78.75	"	"
Brown, Edith, 9 Crowther Ave, Greenwich, N.S.W.	15.60	"	"
Burgess, Geoffrey S., 49 Bridge St, Port Melbourne	105.00	"	"
Burnside, Kennedy W. (estate of), care of Price Waterhouse, 447 Collins St, Melbourne	19.38	"	"
Cadwallader, Herbert E., 346 Canterbury Rd, Surrey Hills	40.38	"	"
Cavanagh, Geoffrey J., 32 Coolabah Rd, Sandy Bay, Tas.	14.39	"	"
Chambers, Susan, 13 Nyssa St, Armidale, N.S.W.	14.70	"	"
Cheshire, John P. A., 393 Pakington St, Newtown	78.75	"	"
Chidgey, John and Judith, care of Price Waterhouse, 447 Collins St, Melbourne	32.45	"	"

Unclaimed Moneys Act 1962

Register of Unclaimed Moneys held by the—

<i>Name of Owner on Books and Last Known Address</i>	<i>Total Amount Due to Owner</i>	<i>Description of Unclaimed Money</i>	<i>Date when Amount first became Payable</i>
\$			
CADBURY SCHWEPPE AUSTRALIA LIMITED—continued			
Chisholm, Bruce A., care of Price Waterhouse, 447 Collins St, Melbourne	118.13	"	"
Cole, Robert M., 30 Hampshire Cres, Alexandra Hills, Qld.	26.25	"	"
Davis, Geoffrey K., 36 Spruce Ave, Warradale, S.A.	52.50	"	"
Deece, Clarence and Dorothy P., care of Price Waterhouse, 447 Collins St, Melbourne	35.44	"	"
Duncan, John, care of Price Waterhouse, 447 Collins St, Melbourne	14.23	"	"
Dutton, Ruth M., 16 Stanley St, Newport Beach, N.S.W.	97.39	"	"
Eisenmenger, Owen L., 2 Leahy St, Beaconsfield, Qld.	10.50	"	"
Field, Mary D., care of Price Waterhouse, 447 Collins St, Melbourne	53.13	"	"
Fisher, Doris, 8 Lorne Grove, Camberwell,	24.15	"	"
Fluck, Edward J., care of Price Waterhouse, 447 Collins St, Melbourne	118.13	"	"
Forbes, Sandra, 8 Sutherland Ave, Paddington, N.S.W.	58.33	"	"
Ford, Arthur (estate of), care of Price Waterhouse, 447 Collins St, Melbourne	52.45	"	"
Franks, Thomas J., care of Price Waterhouse, 447 Collins St, Melbourne	17.70	"	"
Freeman, Robert E., care of Price Waterhouse, 447 Collins St, Melbourne	78.75	"	"
Giotis, Betty, 68 May Terrace, Ottoway, S.A.	26.25	"	"
Gleeson, Vincent S. and Eastway, Richard E., care of V. S. Gleeson & Co., 2 Castlereagh St, Sydney, N.S.W.	77.97	"	"
Gleeson, Vincent S. and Eastway, Richard E., care of Price Waterhouse, 447 Collins St, Melbourne	77.97	"	"
Goodman, Jonathan M., 23 Glenden Rd, Double Bay, N.S.W.	16.75	"	"
Grant, Helene, 2/7 Longworth Ave, Point Piper, N.S.W.	88.57	"	"
Hersch, Harry E., 7/335 Elgar Rd, Box Hill	22.53	"	"
Heavey, Bruce G., 1 Wentworth Ave, North Rocks, N.S.W.	26.25	"	"
Henry Bource Productions Pty. Ltd. Superannuation Fd., care of Newton and Rashleigh, 113 Swanston St, Melbourne	393.75	"	"
Humphreys, Francis G. M., care of Price Waterhouse, 447 Collins St, Melbourne	11.82	"	"
Inwood, Kenneth R., P.O. Box 444, Cannington, W.A.	21.00	"	"
JSC Nominees Pty. Ltd., G.P.O. Box 1029K, Hobart, Tas.	14.02	"	"
Johns, Edith L., 103 Crispe St, Deniliquin, N.S.W.	78.75	"	"
Jolley, Colin R. N., 326 Mitchell Rd, Alexandria, N.S.W.	105.00	"	"
Jones, Adam S., 189 Abercrombie St, Chippendale, N.S.W.	10.50	"	"
Klose, Geoffrey C., 8/7 Winchester St, St. Peters, S.A.	10.50	"	"
Kohn, John C., 133 Waterdale Rd, Ivanhoe	19.38	"	"
Larkin, Jack, 24 Daisy St, Heathmont	97.34	"	"
Latimer, Graham, 3/59 Cawkwell St, Malvern	78.75	"	"
Loria, Hedda, 74/390 Toorak Rd, Toorak	70.14	"	"
Love, James B., care of Price Waterhouse, 447 Collins St, Melbourne	29.04	"	"
Lyons, Maxwell A., care of Price Waterhouse, 447 Collins St, Melbourne	23.63	"	"
Malcam Holdings Pty. Ltd., 303 Collins St, Melbourne	16.75	"	"
Mallinson, Kenneth N., 114 Jolimont Rd, Vermont	31.50	"	"
Malone, Henriette P., 96 Garton St, Princes Hill	10.50	"	"
McGilvray, Ian A., 41 McGregor St, East Malvern	31.50	"	"
McKenzie, Helena A., 22 Joseph St, Mooroopna	25.10	"	"
McKinnon, Marcia E., 251 McKinnon Rd, McKinnon	31.50	"	"
Mitchell, Phyllis C., 5/73 Cremorne Rd, Cremorne, N.S.W.	100.96	"	"

Unclaimed Moneys Act 1962

Register of Unclaimed Moneys held by the—

Name of Owner on Books and Last Known Address	Total Amount Due to Owner	Description of Unclaimed Money	Date when Amount first became Payable
\$			
CADBURY SCHWEPPE'S AUSTRALIA LIMITED—continued			
Mucke, Mary F., 29 Shellcove Rd, Neutral Bay, N.S.W.	23.63	Dividend	10.10.84
Nickolls, Henry C., care of Price Waterhouse, 447 Collins Street, Melbourne	16.07	"	"
Nyalla Investments Pty. Ltd., care of E. A. Gallagher and Co., 199-209 Regent St, Redfern, N.S.W.	191.89	"	"
Park, Kenneth G., and Eileen M., 44 Strada Cres, Mulgrave	32.45	"	"
Parsons, Angus and Brendon, Philip, care of Nield & Co., 77 Grenfell St, Adelaide, S.A.	262.50	"	"
Peacock, Margaret A. P., 25 Fisher Ave, Sandy Bay, Tas.	97.34	"	"
Podbury, Murray B., 5 Vanessa Court, Frankston	84.42	"	"
Pollak, Hedwig, 6/2 Wulworra Ave, Cremorne Point, N.S.W.	19.43	"	"
Quinlivan, Dorothy A., care of Price Waterhouse, 447 Collins St, Melbourne	53.13	"	"
Rielly, Thomas J., care of Price Waterhouse, 447 Collins St, Melbourne	11.82	"	"
Robinson, Brenda O. (estate of), care of Price Waterhouse, 447 Collins St, Melbourne	10.77	"	"
Roeder, Helen, 1 Ardrossan Rd, Engadine, N.S.W.	17.70	"	"
Rossell, Elizabeth A., 48 View Hill Cres, Eltham	48.67	"	"
Shankly, Norman J. (estate of), care of Norman J Shankly and Shankly, 406 Lonsdale St, Melbourne	31.19	"	"
Simmons, Olga R., 5 Taldra St, Box Hill North	11.82	"	"
Simpson, Ruth M. S., 427 Brickfield St, North Parramatta, N.S.W.	39.22	"	"
Small, Aubrey D., 9 Smith Ave, Hurlstone Park, N.S.W.	29.14	"	"
Sulikowski, Stanislaw, 100 Abbotsfield Rd, Claremont, Tas.	26.25	"	"
T. Allan Pty. Ltd., 73 Wakefield St, Adelaide, S.A.	58.33	"	"
Torney, Agnes V., care of Price Waterhouse, 447 Collins St, Melbourne	30.30	"	"
Van Der Bom, Ross and Derek, P.O. Box 86, Horsham	78.75	"	"
Veitch, Walter F. (estate of), care of 2 Bold St, Granville, N.S.W.	14.70	"	"
Vincent, Pamela I. M., 56 Banfield St, Sandringham	16.12	"	"
Vol Alwyn, Constance, care of Price Waterhouse, 447 Collins St, Melbourne	32.45	"	"
Walter, Margaret M., 4 Auvergne Ave, Newtown, Tas.	77.97	"	"
Willmott, Selwyn P., care of Price Waterhouse, 447 Collins St, Melbourne	19.38	"	"
Wilson, Joan L., 13 Studley Park Rd, Kew	20.16	"	"
Woodward, William J., care of Price Waterhouse, 447 Collins St, Melbourne	162.39	"	"
Fox, John F. A., Cottage A, Cashmere Court, 72 Rose St, Christchurch, N.Z.	16.47	"	"
Laspee, Elizabeth, P.O. Box 442, Genoa Ave, Pomona, New Jersey, U.S.A.	27.58	"	"
Plavkova, Marta, care of Price Waterhouse, 447 Collins St, Melbourne	11.02	"	"
Schembri, Carmelo (estate of), 104 Congree Rd, Nosta Malta GC	10.29	"	"
Adams, Robert C., care of Price Waterhouse, 447 Collins St, Melbourne	12.35	"	17.4.84
Allnutt, Helen M., 3 Simmons Plc, Chapman, A.C.T	61.85	"	"
Ball, Violet, 2 Ravenswood Ave, Gordon, N.S.W.	168.75	"	"
Borzell, Adrian, P.O. Box 443, Potts Point, N.S.W.	75.00	"	"
Bradbury, Barbara J., Fernlands Rd, Mount Mebo, Qld.	37.50	"	"
Brown, Edith, 9 Crowther Ave, Greenwich, N.S.W.	14.85	"	"
Bryan, Ralph L., 1-3 Euston Ave, Park Orchards	50.00	"	"
Burnside, Kennedy W. (estate of), care of Price Waterhouse, 447 Collins St, Melbourne	18.45	"	"

Unclaimed Moneys Act 1962

Register of Unclaimed Moneys held by the—

<i>Name of Owner on Books and Last Known Address</i>	<i>Total Amount Due to Owner</i>	<i>Description of Unclaimed Money</i>	<i>Date when Amount first became Payable</i>
\$			
CADBURY SCHWEPPE AUSTRALIA LIMITED— <i>continued</i>			
Busby, Adrienne E., 28A Opmir Cres, Seacliff Park, S.A.	43.20	Dividend	17.4.84
Chambers, Susan, 13 Nyssa St, Armidale, N.S.W.	14.00	"	"
Cheshire, John P. A., 393 Pakington St, Newtown	75.00	"	"
Chidgey, John and Judith, care of Price Waterhouse, 447 Collins St, Melbourne	30.90	"	"
Chisholm, Bruce A., care of Price Waterhouse, 447 Collins St, Melbourne	112.50	"	"
Clarke, Peter R. J., 56 Avoca St, South Yarra	38.50	"	"
Cocker, Brian D., Lot 2, Heath Rd, Kellyville, N.S.W.	16.85	"	"
Crothers, James M. (estate of), care of Margrave Box & Co, 2 Arden St, North Melbourne	89.10	"	"
Crute, Kenneth W., 15 Through Rd, Burwood	35.00	"	"
Deece, Clarence and Dorothy, care of Price Waterhouse, 447 Collins St, Melbourne	33.75	"	"
Duncan, John, care of Price Waterhouse, 447 Collins St, Melbourne	13.55	"	"
Eisenmenger, Owen L., 2 Leahy St, Beaconsfield, Qld	10.00	"	"
Field, Mary D., care of Price Waterhouse, 447 Collins St, Melbourne	50.60	"	"
Forbes, Sandra, 8 Sutherland Ave, Paddington, N.S.W.	55.55	"	"
Ford, Arthur (estate of), care of Price Waterhouse, 447 Collins St, Melbourne	49.95	"	"
Franks, Thomas J., care of Price Waterhouse, 447 Collins St, Melbourne	16.85	"	"
Freeman, Robert E., care of Price Waterhouse, 447 Collins St, Melbourne	75.00	"	"
Gallagher, Edward, 4th Floor, 199–209 Regent St, Redfern, N.S.W.	182.75	"	"
Gleeson, Vincent S. and Eastway, Richard E., care of V. S. Gleeson & Co, 2 Castlereagh St, Sydney, N.S.W.	74.25	"	"
Gleeson, Vincent S. and Eastway, Richard E., care of Price Waterhouse, 447 Collins St, Melbourne	74.25	"	"
Heap, Pamela W., 5 Rustic Dve, Boronia	15.00	"	"
Humphries, Francis G. M., care of Price Waterhouse, 447 Collins St, Melbourne	11.25	"	"
Klose, Geoffrey C., 8/7 Winchester St, St Peters, S.A.	10.00	"	"
Larkin, Jack, 24 Daisy St, Heathmont	92.70	"	"
Liddy, Craig A., 26 Allison St, West Hobart, Tas.	25.00	"	"
Long, Jeffrey, 261 Beaconsfield Pde, Middle Park	44.75	"	"
Love, James B., care of Price Waterhouse, 447 Collins St, Melbourne	27.65	"	"
Lyons, Maxwell A., care of Price Waterhouse, 447 Collins St, Melbourne	22.50	"	"
Macheski, George B., 33 Regnans Ave, Endeavour Hills	10.00	"	"
McNabb, James F. K., 1 View St, Alphington	12.35	"	"
Morris, John W., care of Price Waterhouse, 447 Collins St, Melbourne	18.45	"	"
Morris, Winifred N., 14 Powderham Rd, Caulfield	44.75	"	"
Mucks, Mary F., 29 Shellcove Rd, Neutral Bay, N.S.W.	22.50	"	"
Neal, Elaine N., 47 Cleburn St, Claremont, Tas.	25.00	"	"
Nicholls, Henry C., care of Price Waterhouse, 447 Collins St, Melbourne	15.30	"	"
O'Brien, John, 10 South St, Ascot Vale	40.00	"	"
Park, Kenneth G. and Eileen M., 44 Strada Cres, Mulgrave	30.90	"	"
Pollak, Hedwig, 6/2 Wulworra Ave, Cremorne Point, N.S.W.	18.50	"	"
Quintivan, Dorothy A., care of Price Waterhouse, 447 Collins St, Melbourne	50.60	"	"
Reilly, Thomas J., care of Price Waterhouse, 447 Collins St, Melbourne	11.25	"	"

Unclaimed Moneys Act 1962

Register of Unclaimed Moneys held by the—

<i>Name of Owner on Books and Last Known Address</i>	<i>Total Amount Due to Owner</i>	<i>Description of Unclaimed Money</i>	<i>Date when Amount first became Payable</i>
--	--	---	--

\$

CADBURY SCHWEPPE AUSTRALIA LIMITED—*continued*

Robinson, Brenda O. (estate of), care of Price Waterhouse, 447 Collins St, Melbourne	10.25	Dividend	17.4.84
Shankly, Norman J. (estate of), care of Norman J. Shankly & Shankly, 406 Lonsdale St, Melbourne	29.70	"	"
Shaw, Michael J., 34 Brancourt Ave, Bankstown, N.S.W.	25.00	"	"
Simmons, Olga P., 5 Taldra Street, Box Hill North	11.25	"	"
Small, Audrey D., 9 Smith Ave, Hurlston park, N.S.W.	27.75	"	"
Taylor, John R., 54 Mackenzie St, Toowoomba, Qld.	20.00	"	"
Tormey, Agnes W., care of Price Waterhouse, 447 Collins St, Melbourne	28.85	"	"
Veitch, Walter F. (estate of), care of K. B. Veitch, 2 Bold Street, Granville, N.S.W.	14.00	"	"
Von Alwyn, Constance, care of Price Waterhouse, 447 Collins St, Melbourne	30.90	"	"
Wheeler, Jessie, 8/360 Glen Eira Rd, Elsternwick	37.10	"	"
Willmott, Selwyn P., care of Price Waterhouse, 447 Collins St, Melbourne	18.45	"	"
Woodward, William J., care of Price Waterhouse, 447 Collins St, Melbourne	154.65	"	"
Laspee, Elizabeth, P.O. Box 442, Genoa Ave, Pomona, New Jersey, U.S.A.	26.26	"	"
Plavkova, Marta, care of Price Waterhouse, 447 Collins St, Melbourne 2292	10.50	"	"

NATIONAL COMMERCIAL UNION LIMITED

B.O.L.B. Investments Pty Ltd, 44 Market St, Melbourne,	24.75	Dividend	14.11.84
Benjamin, Frank M., c/o A. Benjamin and Son, 360 Little Collins St, Melbourne,	24.75	"	"
Blyth, James F., c/o Commonwealth Savings Bank, Box 2178, Sydney, N.S.W.	165.00	"	"
Branagan, Bernard J., 54 Kenmore St, Watsonia	12.43	"	"
Callen, Sheila V., 17 Bridge End, Woolstonecraft, N.S.W.	12.43	"	"
Chenery, Arthur, 39 Cross Rd, Kinswood, S.A.	49.50	"	"
Clarke, Doris M., 4 Dine St, Randwick, N.S.W.	41.25	"	"
Brumby, Lesley A., 64 Elizabeth St, Melbourne	49.50	"	"
Crawford, Florence A., 21 Francis Ave, Brighton-Le-Sands N.S.W.	37.18	"	"
Crawford, John, 32 Melbourne Ave, Deakin, N.S.W.	220.00	"	"
Curwen, Isla M., 4 Nyora Ave, The Basin	33.00	"	"
Day, John F. M., 21 Dickson Ave, West Ryde, N.S.W.	16.50	"	"
Deutch, Fernard, Deceased, c/o Ella Deutch, 3 Labossa Gve, Caulfield	11.00	"	"
Dugald Pty Ltd, GPO Box 3579, Sydney, N.S.W.	66.00	"	"
Foster, Iris W., 10 Davey St, Frankston	26.18	"	"
Goodenough, Ashley H., Watt, 39 Brighton Pde, Blackwood S.A.	16.50	"	"
Grant, Beverley M., 2 Lockwood Ave, East Brighton	11.00	"	"
Grben, Beryl J., 2 Aybank Tce, Stonyfell, S.A.	24.75	"	"
Gunn, Elizabeth J., 26 Grosvenor St, Middle Brighton	27.50	"	"
Hill, John, Box 2902, Sydney, N.S.W.	24.75	"	"
Holmes, Helen M., 93 Hopetoun Circuit, Yarralumba, A.C.T.	16.50	"	"
Jeffrey, Richard H. J., 11 Tintern Ave, Carlingford, N.S.W.	1.00	"	"

Unclaimed Moneys Act 1962

Register of Unclaimed Moneys held by the—

<i>Name of Owner on Books and Last Known Address</i>	<i>Total Amount Due to Owner</i>	<i>Description of Unclaimed Money</i>	<i>Date when Amount first became Payable</i>
\$			
NATIONAL COMMERCIAL UNION LIMITED— <i>continued</i>			
Joyve Creek Investments Pty Ltd, c/o Robin Veale and Associates, 320 Carlisle St, Balaclava	16.50	Dividend	14.11.84
Kearns, Margaret, P.O. Box A26, Sydney South, N.S.W.	11.00	"	"
Kearns, Patricia, P.O. Box A26, Sydney South, N.S.W.	11.00	"	"
Long, Jennifer A., 14 Craig Plc, Davidson, N.S.W.	11.00	"	"
Madill, Floyd D. J. and Judith M., c/o Commercial Bank, Cobboldure, Qld	33.00	"	"
Ross-Marteen, John W., 14 Christina Ave, Niagara Park, N.S.W.	16.50	"	"
Martin, Robert L., 34 Stratham Ave, North Rocks, N.S.W.	16.50	"	"
Mauger, Verna L., 20 Gallop Rd, Nedlands, W.A.	24.75	"	"
Mayne, Lewis H., P.O. Box 385, Ipswich, Qld	132.00	"	"
McDonald, Malcolm D., 2 Carrington St, Sydney, N.S.W.	16.50	"	"
McDonald, Thelma G., 7/16 Maple Gve, Toorak	123.75	"	"
McKenzie, Allan S., 21 Moorehouse St, Malvern	16.50	"	"
Moore, Donald J., 11 Upway Rayleigh, Essex, England, U.K.	14.02	"	"
Moore, Gisela M., 31/10 McKye St, Waverton, N.S.W.	16.50	"	"
Mossop, Hugh V., Bears Lagoon	24.75	"	"
Morrow, Frederick J., 18 Lloyd St, Sans Souci, N.S.W.	16.50	"	"
Nicholas, David W., 25 Burns Rd, Wahroonga, N.S.W.	55.00	"	"
Nickolls, Henry C., 62/90 Blues Point Rd, McMahon's Point, N.S.W.	24.75	"	"
Owens, Olive M., 3/30 Pembroke St, Ashfield, N.S.W.	19.25	"	"
Payne, John H., 64 Butler St, Inverell, N.S.W.	110.00	"	"
Pettengell, Yvonne I., Peoples Trees, Jones Rd, Somerville	16.50	"	"
Pratt, Gary J., Factory Rd, Callingnee	13.75	"	"
Pringle, Patricia A., 107 Parkside Dve, Dapto, N.S.W.	24.75	"	"
Pulling, Amy M., 546 Burke Rd, Camberwell	220.00	"	"
Richards, Lilian F., 65 Glencoe St, Rockhampton, Qld	24.75	"	"
Richardson, David B., 16 Glen Ferrie Ave, Myrtle Bank, S.A.	24.75	"	"
Richardson, John T., P.O. Box 483, Warnambool	27.50	"	"
Rogers, Patrick J., P.O. Box 5277, Penola, S.A.	33.00	"	"
Rounsfell, Rita E., 53 Wade St, Nundah, Qld	66.00	"	"
Row, William E., South Road Yannathan, West Gippsland	16.50	"	"
Russell, George K., Barimah Plains, Hesse	49.50	"	"
Scott, Audrey M., 1 Dress Circle Rd, Avalon Beach, N.S.W.	24.75	"	"
Simon, Ronald M., 53 Hat Hill Rd, Blackheath	24.75	"	"
Skitch, Elsa J., c/o Darwin Community Centre, Commercial Studies Department, Winnellie, N.T.	12.43	"	"
Smith, Charles and Myola F., 37 Seathim Rd, Singapore	14.02	"	"
Smith, Gwennyth M., 35 Minimbah Rd, Northbridge, N.S.W.	49.50	"	"
Stacy, Bruce R., P.O. Box 96, Charlestown, N.S.W.	33.00	"	"
Stephenson, Helen M., 8 Rigby St, Willagee, W.A.	24.75	"	"
Tanner, Robert S., 116 King Street, Sandy Bay, Tas	22.00	"	"
Tananna Holdings Pty Ltd, c/o W. G. Bennett, 10 Bass Place, St Ives, N.S.W.	24.75	"	"
Tripet, Ernest A. J., 9 Lumeah St, Punchbowl, N.S.W.	74.25	"	"
Ullner, Karl A. J., 122 Ogilvie Avenue, Echuca	11.00	"	"
Van Gaalen, Patricia V., 23 Larella Cres, Morningson	24.75	"	"
Wallace, Wayne G., 3 St Stephens Ave, Sany Bay, Tas	24.75	"	"
Walter, Kenneth G., 4 Auvergne Ave, New Town, Tas	24.75	"	"
Warren, Geoffrey R., 815 Armstrong St, North Ballarat	110.00	"	"
Watson, June, 39 Thornburgh St, Oxley, Qld	17.38	"	"
Williams, Christine I., 7 Swallow St, Slade Point, via Mackay, Qld	38.50	"	"
Young, William A., G.P.O. Box M948, Perth, W.A.	82.50	"	"

Unclaimed Moneys Act 1962

Register of Unclaimed Moneys held by the—

<i>Name of Owner on Books and Last Known Address</i>	<i>Total Amount Due to Owner</i>	<i>Description of Unclaimed Money</i>	<i>Date when Amount first became Payable</i>
\$			
NATIONAL MUTUAL			
Fitzgerald, M. E.	478.66	Premium	3.10.83
Ponopoulos, N.	160.51	"	4.10.83
Casey, A., 4 Kurrajong Cl, Viewbank	49.00	"	5.10.83
Marslen, C. J., 51 Alexandra Pde, Nth Fitzroy	83.04	"	"
Tribe, P. N.	42.10	"	19.10.83
Borg, A.	2152.05	"	25.10.83
Allan Low Tours Pty Ltd	133.30	"	"
Ripper, T. A., 12 Ellen St, Parkdale	12.36	"	"
Stanton, N. W.	175.49	"	27.10.83
Jenkins, G. E., 1/697 David St, Albury, N.S.W.	92.14	"	"
Morgan, N. F.	10.21	"	"
Kelly, T.	78.33	"	"
Moran, J. L., 6 Stanley St, Wodonga	30.43	Refund	2.11.83
Callaghan, L.	51.00	"	"
Lacey, G. J., 66 Richmond St, Cooe Bay, Qld.	61.82	"	4.11.83
Tucimskas, E.	89.36	"	"
Watson, R. J.	83.20	"	"
Mitchell, R. A., 12 Fulham Cl, Frankston	22.16	Premium	7.11.83
Mauris, J. A., 575 Spencer St, West Melbourne	26.50	"	"
Stamatagos, P., Centennial Ave, Brunswick	48.14	Payment	8.11.83
Day, C. A., 18 Lorne Rd, Prahran	26.01	Refund	"
Bongiomo, A. S.	362.92	"	"
Bell, C. J., 24 Warnes Rd, Mitcham	58.84	"	11.11.83
Williams, A.	14.00	Premium	15.11.83
Hendricks, G. B. (estate of), care of J. C. De Kerer, Assoc. Barr and Solicitors, Shop 2, 25 Boronia Rd, Boronia	164.66	Refund	17.11.83
Martin, D. J., 4 Lisfarron Ave, Cobram	100.00	"	22.11.83
Collins, M., 45 Kurrawa Cres, Patterson Lakes	81.42	"	25.11.83
S. McLarty-Hycraft Carpets Pty Ltd, Harris Rd, Five Dock, N.S.W.	123.80	"	29.11.83
Audsley, I. C., 80 Rose Ave, Norlane	17.90	"	1.12.83
Brien, R. A., 3 Brallos Ave, Holsworthy, N.S.W.	222.33	"	5.12.83
Flexitime Pty Ltd, P.O. Box 49, Bankstown, N.S.W.	38.00	"	"
Rawls, W. H., 1 Keats St, Sandringham	149.94	Premium	6.12.83
Dobbin, S. C., 17 McDougall St, Fawkner	16.16	"	"
Taylor, S. J., 8 Clarence St, East Bentleigh	20.00	"	7.12.83
Jones, C. A., 4/275 Nepean Hwy, Frankston	20.00	"	"
Jones, M. P., Lot 40, Wonga Rd, Millgrove	15.42	"	9.12.83
Jones, J. A., 5 Kalista Plc, West Melton	14.38	"	"
Blewitt, J. R., 30 Vaniesleigh Rd, Upper Ferntree Gully	49.36	"	12.12.83
Phillips, G. R., 7 Stanley Gve, Canterbury	47.84	"	"
Loone, K. C., 38 Timberglade Rd, Montrose	28.05	"	13.12.83
Casey, A.	14.00	"	14.12.83
McCaughy, A. M., 66 Queens St, Colac	63.46	"	16.12.83
Anthony, J.	31.61	"	"
Cooper, P. M., 11 Bader Crt, Nth Ringwood	25.87	"	22.12.83
Petrov, E., 4 Kionga St, Clayton	95.62	"	23.12.83
N.M.L.A.—S. E. Perring, 1804 Pittwater Rd, Bayview, N.S.W.	629.56	"	3.1.84
C.D.R.—MacDonald, 67 St Andrews Dve, Chirnside Park	87.14	"	4.1.84
Scherger, A. N.	14.80	"	"
Citera, F., 18 Neasham Dve, Nth Dandenong	37.02	"	6.1.84
Robertson, D. J.	12.01	"	"

Unclaimed Moneys Act 1962

Register of Unclaimed Moneys held by the—

<i>Name of Owner on Books and Last Known Address</i>	<i>Total Amount Due to Owner</i>	<i>Description of Unclaimed Money</i>	<i>Date when Amount first became Payable</i>
\$			
NATIONAL MUTUAL— <i>continued</i>			
Case, N. J., 2 Leask Ave, Mildura	69.61	Premium	10.1.84
Wishart, K. J., 13 Alkira Plc, Mildura	12.90	"	12.1.84
Keith, W., 50-54 Robinson St, Dandenong	82.00	Refund	23.1.84
Casauria, M., 1/5 Malcolm Cres, Doncaster	79.66	"	"
Lianea, F., 6/32 Jersey Pde, Carnegie	820.40	"	24.1.84
Pearce, L. C., 1/25 Dunoon St, Murrumbidgee	50.64	"	"
Bowen, G. J.	42.00	"	26.1.84
Keith, W., 50/54 Robinson St, Dandenong	200.00	Premium	"
Hojanik, J.	100.00	"	6.1.84
O'Neil, O. F., 5/20 Broadway St, Chelsea	80.00	"	27.1.84
Hodges, R., 9 Barry St, Bendigo	26.35	"	2.2.84
Warner, J. H., "The Cottage", Olinda Cres, Olinda	49.02	"	"
Thompson, K. J.	82.20	"	9.2.84
Batwell, C. R.	15.00	"	"
Thorburn, Y. M., 81 Hornby St, Windsor	10.00	"	13.2.84
Guages, S.	26.00	"	"
Young, A., 49 Malop St, Geelong	131.54	"	14.2.84
O'Leary, J. H., 15 Illawong Crt, Patterson Lakes	111.65	"	"
Kearney, T. A., 10 Arco St, Bairnsdale	136.61	"	15.2.84
Ford, J. N., 2/41 Old Geelong Rd, Hoppers Crossing	10.48	Refund	17.2.84
Erskine, B. A., 70 Sandringham Pde, Newtown	12.58	"	"
Wilson, W.	41.00	"	22.2.84
Millar, A. H. M., 614 Bell St, West Preston	50.40	"	23.2.84
Archer, M. J., 52 Lincoln Ave, Glen Waverley	97.50	"	29.2.84
Martinengo, R. T., 6 Mitton St, Elwood	122.94	"	1.3.84
Gooden, B. J., 190 St Albans Rd, Kealba	17.00	"	"
Cartwright, J., 3/224 Grote St, Adelaide, S.A.	1013.00	Premium	2.3.84
Tobin, G., 2 Ballater St, Essendon	26.00	Commission	7.3.84
Perry, G.	20.62	"	"
Shave, S. L., 56 Dunsterville Cres, Frankston	33.77	Premium	8.3.84
Ball, C.	80.00	Commission	13.3.84
Falsone, M. M., 21 Tasman Dve, Bundoora	20.42	Premium	"
Halcarz, M., 5 Kinnear St, Footscray	340.90	"	19.3.84
Borg, P., 12/24 Rooney St, Maidstone	12.15	"	21.3.84
Kaliniy, J.	14.29	"	"
Gerlach, R.	239.59	"	23.3.84
Taylor, M.	39.25	"	"
Bunting, R. J., 32 Sydney St, Albion	16.35	"	29.3.84
Baxter, C. E.	146.40	"	30.3.84
Finkelstein, R.	528.54	"	2.4.84
Margetts, D. E., 7 Tattler Plc, Rowville	53.51	"	3.4.84
Warner, H., "The Cottage", Olinda Cres, Olinda	38.34	"	"
Thomas, P. R., 7 Russell St, Caulfield	164.43	"	"
Case, R. A.	2706.31	Balance	"
Hill, D. A., 14 Somerset Ct, Werribee	20.22	Refund	4.4.84
Carguard Insurance Agency	19.00	Commission	"
Plain, K., 19 Albert Rd, Beechworth	378.32	Refund	"
Martinali, J. W. H.	44.31	"	10.4.84
Browell, G. R.	42.73	"	12.4.84
Allen, S. L.	27.24	"	"
Hill, R. G. R.	40.58	"	"
Clarke, J. L.	99.50	"	"

Unclaimed Moneys Act 1962

Register of Unclaimed Moneys held by the—

<i>Name of Owner on Books and Last Known Address</i>	<i>Total Amount Due to Owner</i>	<i>Description of Unclaimed Money</i>	<i>Date when Amount first became Payable</i>
\$			
NATIONAL MUTUAL—continued			
Francis, G. P., 8 Florida Dve, Ferntree Gully	12.38	Refund	16.4.84
Edwards, J. C. 19 Edinburgh Rd, Lilydale	16.75	"	"
Younger, R. W.	95.13	"	"
Plant, T. F.	11.34	"	18.4.84
Lay, R.	154.00	Commission	"
Adams, A. R.	10.48	Premium	19.4.84
Law, E. K.	206.56	"	26.4.84
Gandolfo, L. A., 8/5 Seaver Rd, Reservoir	301.00	"	27.4.84
Kobel, J., 38 Josephine St, Oak Park	96.41	"	1.5.84
Marchetti, S. P.	23.28	"	"
Ward, E. J., 16 Sassafra Dve, Frankston	77.40	"	3.5.84
Newman, P. L.	29.20	"	"
McLeish, G. A. H., 1/7 Alexander Ave, South Yarra	297.91	Refund	7.5.84
Vogele, L. W., cnr Gembrook and Army Rds, Upper Pakenham	20.00	"	9.5.84
Kerr, B. J.	50.07	"	"
Graves, R.	33.35	"	"
McLeish, G. A. H., 1/7 Alexander Ave, South Yarra	28.16	"	10.5.84
Trustees of Irwell Retirement Association Plan, (address unknown)	317.00	"	14.5.84
McLeod, K. H.	11.57	"	"
Spring, C.	60.52	"	15.5.84
Payne, G. J., 44 Marklin St, Cranbourne	17.60	"	"
Carguard Insurance Agency (address unknown)	19.00	Commission	16.5.84
Serban, M., 184 Mt Pleasant Rd, Nunawading	194.83	Refund	"
Micallef, M., 15 Wodgen Rd, Leppington, N.S.W.	87.43	"	17.5.84
Crowe, P. R., 550 Thurgoona St, Albury, N.S.W.	122.52	Refund	17.5.84
Hall, M. S.	83.51	"	23.5.84
Mammuliti, B.	106.69	"	"
Zaffris, I., 39 Lipton Dve, North Dandenong	330.00	"	25.5.84
Lockwood, T. R., 9 Elgin St, Pascoe Vale South	70.52	"	29.5.84
Caruso, A.	24.14	"	31.5.84
Kerr, R. D.	173.62	"	"
Thompson, C. J., 2 Elray Crt, Tullamarine	64.14	"	5.6.84
Connell, J. W.	50.80	"	"
Peters, C. J. D.	16.38	"	8.6.84
Sneesby, B. A.	16.38	"	"
Cunningham, L. E.	8818.00	"	12.6.84
Isles, R. T., 107 Grant Rd, Sommerville	14.16	"	13.6.84
Bautch, G. L.	19.03	"	14.6.84
Kailainathan, S., 85 Caroline St, South Yarra	30.85	"	15.6.84
Knight, A. M.	135.00	"	"
Kerr, R. D., 18 Melsona St, Sandringham	236.38	"	18.6.84
Watson, R. A., 2 Nemet Crt, Noble Park	100.00	"	20.6.84
Allen, P. R., 33 Jacana Ave, Frankston	37.76	"	21.6.84
McIntosh, G. I., 16 Wallace St, Maidstone	70.44	"	"
Curtis-Smith, J. E., 7 Hulme Dve, Wangaratta	53.66	"	22.6.84
Nudel, L.	82.17	"	"
Matthews, E. M., 37 Ferguson Rd, Shepparton	20.00	"	25.6.84
Horner, I. A. J., 3 Rinella Crt, Mt Eliza	10.00	"	26.6.84
Butt, L.	19.73	"	"
Zervakis, A.	77.80	"	"
Polglase, A. L.	39.16	Premium	29.6.84
Lambert, J. F.	106.61	"	2.7.84

Unclaimed Moneys Act 1962

Register of Unclaimed Moneys held by the—

<i>Name of Owner on Books and Last Known Address</i>	<i>Total Amount Due to Owner</i>	<i>Description of Unclaimed Money</i>	<i>Date when Amount first became Payable</i>
\$			
NATIONAL MUTUAL— <i>continued</i>			
Boughton, A. M.	20.11	Premium	2.7.84
Versace, C. D. N.	13.96	"	"
Mackenzie, S. C. W.	61.29	"	"
Foote, G. F.	433.87	"	4.7.84
Southby, G. R.	20.89	"	"
McRobert, S. I.	42.70	"	"
Tresize, A.	30.76	"	"
Tennant, N. A.	14.40	"	9.7.84
Hoyle, B. W.	152.46	"	10.7.84
Simpson, C. E.	222.64	"	11.7.84
Peacock, I. J.	80.00	"	"
Lastov, J.	13.70	"	13.7.84
Vodden, R. W.	82.19	"	18.7.84
Cuddy, A. C.	135.00	Refund	"
Dore, M. G.	53.04	"	19.7.84
Beard, M. J., "Golf Links", Shelford	72.90	"	20.7.84
Sinclair, M. A.	48.69	"	23.7.84
Carguard Insurance Agency	73.00	Commission	25.7.84
Sheen, R. C.	11.98	Premium	26.7.84
Walker, L. P.	17.90	"	"
Versace, A.	17.98	"	30.7.84
Maguire, L. P.	348.29	"	"
Morris, J.	103.65	"	"
Graetz, G. H.	10.00	"	31.7.84
Coates, G. D.	12.72	"	"
Lord, P. J.	62.10	"	"
Eaton, Francis E., Fidelity Meat Industry Ltd., Corowa, N.S.W.	241.47	Refund	1.8.84
Kearney, L. F.	283.69	"	"
Justice, J. E.	44.39	"	"
Broadhurst, K. R., 31 Arthur St, Fairfield	40.00	"	7.8.84
Baker, R. L.	14.46	"	8.8.84
Carguard Insurance Agency	19.00	Commission	"
Bouzis, A.	32.63	Premium	10.8.84
McCormick, K. M.	65.49	"	"
Day, F. M.	57.81	"	"
Vassana, A. J.	94.20	"	14.8.84
Cooray, R. D.	12.49	Refund	"
Shore, J.	43.12	"	"
Barthelson, R.	66.02	"	15.8.84
Moroney, K. A.	11.91	"	16.8.84
Watson, M. F.	62.07	"	"
Dowd, M. D.	59.58	"	"
Robert Ritchie (Sebastopol) Pty. Ltd., 619 Springvale Rd, Glen Waverley	89.98	"	17.8.84
Hunter, J. R.	27.16	"	"
Stonehouse, J. A.	30.00	"	"
Sandon, P. M.	87.36	"	"
Regan, B.	273.67	"	21.8.84
De Bono, M. V.	97.60	"	"
Storey, G. G.	10.70	"	"
Linden, H. C., 30 Balmoral St, Shepparton	45.94	"	22.8.84
Pidgeon, M. K.	78.40	"	"

Unclaimed Moneys Act 1962

Register of Unclaimed Moneys held by the—

<i>Name of Owner on Books and Last Known Address</i>	<i>Total Amount Due to Owner</i>	<i>Description of Unclaimed Money</i>	<i>Date when Amount first became Payable</i>
\$			
NATIONAL MUTUAL— <i>continued</i>			
Kasta and Farmer Pty. Ltd	49.26	Premium	24.8.84
Cain, R. K.	30.63	"	"
Beggs, A. J.	20.00	"	"
Thompson, H. G.	48.00	"	"
McKenzie, J. A.	17.58	"	"
Pulford, L. R.	37.99	"	27.8.84
Turnbull, P. R.	23.85	"	28.8.84
Alferi, F.	144.00	"	29.8.84
Grieve, N. M.	289.00	"	"
Thompson, R. G.	271.88	"	"
Shore, D. J.	19.36	"	"
Bunting, R. J.	10.28	"	30.8.84
Lay, G. R., 2/43 Scott St, Dandenong	67.40	"	31.8.84
Clayton, M. L., Boundary Rd, Carrum Downs 2283	150.00	"	26.1.84
G. A. THOMPSON & CO.			
Zaguileg, Wendy, Flat 8, 9-11 York St, North Fitzroy	16.10	Refund	8.8.84
Spiteri, M., and Evans, S., 4/10 Munro Ave, Carnegie	160.00	"	10.4.84
Ash, R. P., 1/11 Rothchild St, Glenhuntly	41.43	"	27.6.84
Avila, I., 13/15 Poplar Gve, Carnegie	90.00	"	31.8.84
Gilmore, T., 6/34 Rosella St, Murrumbeena	88.42	"	2.1.85
Sharp, H., 6/25 Hobart Rd, Murrumbeena	12.30	"	1.2.85
Kockevich, J., 8 Murray St, East Brighton	141.99	"	22.3.85
Pearcey, D., 5/21 Ulupna Rd, Ormond	25.76	"	28.10.83
Lynch, I., 3/73 Alexandra Ave, South Yarra	270.00	"	3.12.84
Charters, Z., 8/98 Park St, St. Kilda 2282	21.87	"	16.3.84
NZI LIFE			
White, K. A.	42.42	Refund	—2.85
Rixon Hairdressing	15.00	"	—2.85
Eccles, S. J. 2290	122.10	"	—2.85
ERROL STEWART REAL ESTATE PTY. LTD.			
Carew, B.	100.00	Bond	..
Hadfield	10.00	Deposit	..
Faulkner	100.00	"	..
Finneran 2310	20.00	"	..

Unclaimed Moneys Act 1962

Register of Unclaimed Moneys held by the—

<i>Name of Owner on Books and Last Known Address</i>	<i>Total Amount Due to Owner</i>	<i>Description of Unclaimed Money</i>	<i>Date when Amount first became Payable</i>
\$			
THE BRITISH PETROLEUM COMPANY OF AUSTRALIA LIMITED			
Anderson, B. J., 31 Noga Ave, Keilor East	10.90	Interest	31.8.84
Brown, A. G. and Head, N. R., 37 Canberra Cres, Campbelltown, N.S.W.	322.50	"	"
Callaghan, G. W., 41 Grange Rd, Toorak	10.85	"	"
George, V. J., 14 Myrtle St, Clifton Hill	16.40	"	"
Grover, M., 53 Savis Ave, South Yarra	53.75	"	"
Higgs, N. I., 10/22 Collingwood St, Drummoyne, N.S.W.	327.00	"	"
Hollaway, V. L., 53 Davis Ave, South Yarra	107.50	"	"
Leviston, D., Simond Arcade, Wells St., Frankston	42.50	"	"
Masonic Memorial Homes Trust Inc., 91 Diagonal Rd, Somerton Park, S.A.	1075.00	"	"
McCall, M. M., 279 Wantirna Rd, Ringwood	21.50	"	"
Tinker, S. A., 3/32 Maitland St, Glen Iris	53.75	"	"
Bryan, L. T. (estate of), 4/165 Stokes St, Port Melbourne	17.42	Payment	20.3.85
Eldridge, C. and C., Flashman Ave, Nyngan, N.S.W.	20.00	"	18.1.85
Wings Australia Pty. Ltd., c/o BP Australia Limited, Albert Rd, Melbourne	226.00	"	"
McMinn, W. R. and M., c/o BP Australia Limited, Albert Rd, Melbourne	10.00	"	"
Virisila, A., c/o BP Australia Limited, Albert Rd, Melbourne	30.00	"	7.9.84
Downes and Wills Pty. Ltd., 192 Hume Hwy, Mittagong, N.S.W.	462.93	"	24.10.84
Greigg, K. and D., 192 Hume Hwy, Mittagong, N.S.W.	14.04	"	21.2.85
Child, N. and Kirk, D., c/o BP Australia Limited, Albert Rd, Melbourne	10.00	"	24.10.84
Newcastle Hi-Tensile Bolt Co., P.O. Box 71, Mayfield, N.S.W.	66.60	"	"
Newcastle Hi-Tensile Bolt Co., P.O. Box 71 Mayfield, N.S.W.	187.85	"	28.12.84
Locksmiths Supply Co., P.O. Box 216, North Melbourne	19.25	"	21.11.84
McClellan, A. A. J. and D. D., P.O. Box 1, Gilgandra, N.S.W.	884.86	"	"
Southern Cross Trailers Pty. Ltd., P.O. Box 19, Milperra, N.S.W.	884.86	"	"
Southern Cross Trailers Pty. Ltd., P.O. Box 31, Milperra, N.S.W.	323.41	"	30.11.84
Kodak (Australasia) Pty. Ltd., P.O. Box 31, Allandale, N.S.W.	97.00	"	"
Jones, A. E., 9 Sterling St, Fern Tree Gully	49.41	"	19.12.84
R. M. Pitcher Constructions, 28 Munroe St, Baulkham Hills, N.S.W.	459.00	"	3.1.85
Johnson, R. M. J. and B., 108 Rusden St, Armadale, N.S.W.	10.00	"	23.1.85
No Fibs Publishing Pty. Ltd., P.O. Box 205, Brookvale, N.S.W.	150.00	"	31.1.85
Stepan, Jaques S. J., 50 Bridge St, Sydney, N.S.W.	125.00	"	21.2.85
Hawker Pacific Pty. Ltd., P.O. Box 90, Wagoona, N.S.W.	10.00	"	"
Leviston, D., Simond Arcade, Wells St, Frankston	42.50	Interest	28.2.85
Robertson, J. E., 89 Chelsea Rd, Chelsea Heights	550.00	"	"
Showe, C. J., 14 Villers St, Frankston	42.50	"	"
Syred, C. M., 11 Old South Rd, Bowral, N.S.W.	425.00	"	"
2285			
SYME MEDIA PTY. LTD.			
Holden, A., 6 Walker St, Balwyn	15.94	Expenses	10.11.83
Spicer, S., 10 Frost St, Orange, N.S.W.	14.50	Commission	22.5.84
Dandtonians, care of Dandenong Football Club	100.00	Annual Subs.	24.5.84
Swinstead, T., 52 Winuna Rd, Mt. Eliza	55.89	Expenses	29.5.84
Henderson, G., P.O. Box 601, Southport, Qld	48.00	Contributor	6.8.84
Monahan Dayman Adams, 578 St. Kilda Rd, Melbourne	150.00	Contributions	1.10.84
McKelvey, J., 19 Jame St, Berwick	20.00	Prize	4.2.85
Powell, B., Market Rd, Werribee	30.00	Sponsorship	25.3.85
Corless, A., 85 A Beckett Rd, Narre Warren	15.00	Work Experience	16.4.85
2284			

Unclaimed Moneys Act 1962

Register of Unclaimed Moneys held by the—

<i>Name of Owner on Books and Last Known Address</i>	<i>Total Amount Due to Owner</i>	<i>Description of Unclaimed Money</i>	<i>Date when Amount first became Payable</i>
\$			
DAVID SYME & CO., LIMITED			
Cochrane, G., Personal Investments, Sydney Office, N.S.W.	61.00	Expenses	14.8.84
Davis, S. L., 26–28 Hunter St, Sydney, N.S.W.	108.40	"	20.9.84
Stevens, M., 70–72 Ringwood St, Ringwood	208.00	"	27.9.84
Webster, Wayne, 146 Boronia Rd, Vermont	70.00	"	18.9.84
Dodd, Peter, 3/15 Leigh Rd, Croydon	68.00	"	"
Stevens, Mick, 70–72 Ringwood St, Ringwood	239.00	"	"
D'Arcy, care of 3AK	300.00	"	4.10.84
Whitfield, Alan, 1243 North Road, Oakleigh	500.00	"	10.10.84
Webster, S., 68 Heyinton Ave, Thomastown	190.70	"	9.10.84
Branch, Roland	145.00	"	1.11.84
Loney, B. (Contractor)	201.20	"	29.11.84
Warren, G. E., 95 Willis Street, Portarlington	34.16	"	3.2.84
Porter, I., 90 Stanley St, Nth Adelaide, S.A.	32.35	"	6.2.84
Nash, P., P.O. Box 66, East Doncaster	43.24	"	5.3.84
Mould, J., 9 Exford Rd, Melton South	23.40	"	25.3.84
Laffy, M., 15 Aberdeen Rd, Prahran	36.92	"	19.4.84
Way, Lewis M., (estate of), England	54.40	"	2.4.84
Green, J., 10 Elm Grv, Richmond	30.00	"	3.4.84
Quigley, F., 8/10 Daly St, Oakleigh	46.36	"	7.6.84
Williams, A., David Syme & Co., 50 Margaret St, Sydney, N.S.W.	25.00	"	29.5.84
O'Connell, Peter, Sydney Office, N.S.W.	120.00	"	6.6.84
Camperdown Primary School (Marketing)	35.00	"	14.6.84
O'Dwyer, G., Hastings Rd, Cranbourne	49.20	Salaries	6.6.83
Bright, W., 27 Treloar Cres, Braybrook	28.30	"	10.1.84
Whittington, R & S., 100 Elizabeth Bay Rd, Sydney, N.S.W.	43.10	"	"
Lehman, A., 26 Blesington Pl, East St. Kilda	35.20	"	30.1.84
Halliwell, A., "The Admiral Bembow", Cockatoo	52.20	"	7.2.84
Bright, W., 27 Treloar Cres, Braybrook	59.50	"	"
Shiffefs, M., 3/127 Dandenong Rd, Windsor	690.20	"	6.3.84
Murphy, J., 6/218 Lennox St, Richmond	18.30	"	"
Demaneuf, E., 6 Callantina Rd, Hawthorn	52.20	"	"
Ward, M., 2/9 Freeman St, Ringwood East	37.90	"	20.3.84
Hecker, K., care of Post Office, Lilydale	63.60	"	3.4.84
Svikulis, G., 127 McFadzean Ave, Reservoir	60.60	"	16.4.84
Barrett, G., 3/8 Darling St, South Yarra	42.50	"	8.5.84
Robinson, P., 1 Clive Rd, Hawthorn	44.80	"	"
MacArthur, T., 3/20 Lamrock Ave, Bondi Beach, N.S.W.	34.00	"	"
Wall, D., P.O. Box, 220, Redfern, N.S.W.	12.00	"	"
Segal, D., 7/13 Montgarth Ave, Hawthorn East	55.80	"	21.5.84
MacArthur, T., 3/20 Lamrock Ave., Bondi Beach, N.S.W.	36.00	"	"
Allen, L., 12/417 Glebe St, Glebe, N.S.W.	104.30	"	28.5.84
Taylor, M., 12 Smart St, Sunshine	33.50	"	"
North, D., A.N.U., Canberra, A.C.T.	117.60	"	4.6.84
Comedy Acts for Sale Pty. Ltd., 121 Gore St, Fitzroy	55.80	"	"
Newton-Smith, C., care of 250 Spencer St, Melbourne	48.50	"	"
Walker, C., 1/43 Barcom Ave, Darlinghurst, N.S.W.	55.80	"	"
Tunley, S., 124 Walker St, Sydney, N.S.W.	138.00	"	"
Ward, W., 11 Montgomery St, Richmond	83.40	"	3.7.84
Noble, T., 175 St. Georges Rd, North Fitzroy	18.30	"	9.7.84
Webster, A., 32 Walsh St, West Melbourne	42.50	"	"
O'Neill, T., 91 Baden Powell Dve, Mt. Eliza	21.90	"	16.7.84

Unclaimed Moneys Act 1962

Register of Unclaimed Moneys held by the—

<i>Name of Owner on Books and Last Known Address</i>	<i>Total Amount Due to Owner</i>	<i>Description of Unclaimed Money</i>	<i>Date when Amount first became Payable</i>
\$			
DAVIDSYME & CO., LIMITED— <i>continued</i>			
Smith, G. R., 59 Marriott St, Parkdale	21.90	Salaries	16.7.84
Birsky, M., 40 Donfern St, Mt. Gravatt, Qld.	18.30	"	30.7.84
Blackman, K., Monash University, Clayton	83.70	"	6.8.84
Scott, M., 48 Chapel St, St. Kilda	121.60	"	13.8.84
Porter I., 9/47 Rockley Rd, South Yarra	69.10	"	"
Redford, S. K., 34 Nicholson St, Fitzroy	77.30	"	20.8.84
Collins, W., 6 Lempriere Ave, Balaclava	69.00	"	"
Stewart, I., Lot 47, Ridge Hill Rd, Helena Valley, W.A.	24.60	"	"
All Night Graphics, 5 Finton CIs, Glen Waverley	250.00	"	27.8.84
Ryan, A., 17 York St, Noth Fitzroy	24.20	"	"
Ryan, P., 19/17 Billyard Ave, Elizabeth Bay, N.S.W.	21.90	"	"
Harper, P., 36 Baden Powell Dve, Frankston	20.00	"	3.9.84
Honybun, R., Room 120, Industry House, National Circuit, Barton, A.C.T.	91.60	"	"
Martin, P., 53 Hedbury Ave, Watsonia	58.60	"	"
Stevens, M., 4/19 Neptune St, St. Kilda	27.90	"	"
Pickering, A. R., 16 Barnet St, Highett	106.30	"	"
Moxon, B., 24 Charlotte St, Dundas, N.S.W.	48.50	"	"
Porter, I., 9/47 Rockley Rd, South Yarra	21.90	"	"
Barton, R. J., 68 Arthur Circle, Forrest, A.C.T.	381.60	"	24.9.84
Grant, C., 30 Beverley St, East Doncaster	48.50	"	"
Barton, R., 68 Arthur Circle, Forrest, A.C.T.	83.70	"	"
Berry, A., 12/5 Fulton St, East St. Kilda	18.30	"	8.10.84
Clarke, S., 11/20 Grandview Ave, Prahran	11.00	"	"
West, R., 14 Dunley Ave., Edithvale	21.90	"	"
Stockley, G., 19 Thompson St, Garran, A.C.T.	18.30	"	"
Lund, B., P.O. Box 48, Frankston	27.90	"	"
O'Dwyer, G., Hastings Rd, Cranbourne	97.00	"	"
Newlyn, D., P.O. Box 102, Greenacre, N.S.W.	42.50	"	"
Simson, A., 9 Yendon Rd, Glenhuntly	42.50	"	22.10.84
Brownlee, M. A., 38 Fraser St, Richmond	83.40	"	29.10.84
Page, C., 34 Elm Gve, Richmond	14.60	"	"
Whiting, A., 224 George St, Erskineville, N.S.W.	69.10	"	5.11.84
Stewart, I., Lot 47, Ridge Hill Rd, Helena Valley, W.A.	18.90	"	"
Tremath, L., 9 Kurak Rd, Yarrambat	31.60	"	"
Campbell, E. D., 265 Riverside Rd, Hawthorn	498.00	"	"
Cooke, K., 4/2 Mansfield St, Glebe, N.S.W.	27.90	"	13.11.84
Hyde, G., Market Rd, Brooklyn	55.80	"	"
Usher, R., 30 Edinburgh St., Richmond	104.30	"	"
Whiting, A., 224 George St, Erskineville, N.S.W.	69.10	"	"
Whiting, A., 224 George St, Erskineville, N.S.W.	69.10	"	19.11.84
McDonough, E., 11 Fairy St, Ivanhoe	83.40	"	26.11.84
Whiting, A., 224 George St, Erskineville, N.S.W.	69.10	"	"
Green, J., 185 Drummond St., Carlton	104.30	"	"
Noble, T., 175 St. Georges Rd, North Fitzroy	69.10	"	3.12.84
Whiting, A., 224 George St, Erskineville, N.S.W.	69.10	"	"
Whiting, A., 224 George St, Erskineville, N.S.W.	69.10	"	10.12.84
Collins, W., 6 Lempriere Ave, Balaclava	69.00	"	"
Grimmer, R., P.O. Box 155, Balaclava	140.80	"	18.12.84
Thomas, A. H., 16 Stanley St., Carrum	57.70	"	"
Whiting, A., 224 George St, Erskineville, N.S.W.	69.10	"	"

Unclaimed Moneys Act 1962

Register of Unclaimed Moneys held by the—

<i>Name of Owner on Books and Last Known Address</i>	<i>Total Amount Due to Owner</i>	<i>Description of Unclaimed Money</i>	<i>Date when Amount first became Payable</i>
S			
DAVID SYME & CO., LIMITED—continued			
Whiting, A., 224 George St, Erskineville, N.S.W.	138.20	Salaries	31.12.84
Masterpiessie Sports Promotions, 22 Bareena Drv, Mt. Eliza	1460.00	"	"
Rodgers, A. R., 55 Kelvin Ave, Montmorency	115.40	"	8.1.85
Whiting, A., 224 George St, Erskineville, N.S.W.	69.10	"	"
Bowne, A., 71 Thomson St, Barrington, N.S.W.	192.50	"	"
Maskell, V., 47 Banole Ave., East Prahran	14.60	"	"
Wilmoth, P., 1/22A Clendon Rd, Toorak	55.80	"	15.1.85
Rodgers, A. R., 55 Kelvin Ave, Montmorency	57.70	"	"
Whiting, A., 224 George St, Erskineville, N.S.W.	69.10	"	"
Laurel, Allen, 12/417 Glebe St, Glebe, N.S.W.	136.60	"	"
Lampe, A., 235 Jones St, Broadway, N.S.W.	138.00	"	"
Cummins, R. A., 359 George St, Fitzroy	44.00	"	"
Rodgers, A. R., 55 Kelvin Ave, Montmorency	82.90	"	22.1.85
Whiting, A., 224 George St, Erskineville, N.S.W.	69.10	"	"
Dollimore, J., Department of Defence, Canberra, A.C.T.	166.00	"	"
Robilliard, Department of Defence, Canberra, A.C.T.	173.40	"	"
Whiting, A., 224 George St, Erskineville, N.S.W.	69.10	"	26.1.85
Robinson, K. A., 62 Hickford St, Reservoir	145.30	"	5.2.85
Burt, J., P.O. Box 57, East Melbourne	87.40	"	"
Neilson, P., G.P.O. Box 2434, Brisbane	24.20	"	"
Lowe, P., 5/45 Fitzgerald St, South Yarra	89.70	"	"
Whiting, A., 224 George St., Erskineville, N.S.W.	69.10	"	"
Dollimore, J., Department of Defence, Canberra, A.C.T.	166.00	"	"
Pearle, M., 235 Jones St, Broadway, N.S.W.	166.00	"	"
Wyplus Pty. Ltd., 235 Jones St, Broadway, N.S.W.	750.00	"	"
Jamrozic, W., 110 Fitzroy St, Surry Hills, N.S.W.	35.20	"	"
Brayshaw Ent., 19 Fern St, Swanbourne, W.A.	70.00	"	"
Thwaites, T. P., 69 Shields St, Flemington	66.80	"	12.2.85
Rodgers, A. R., 55 Kelvin Ave, Montmorency	82.90	"	18.2.85
Wyplus Pty. Ltd. 235 Broadway, Sydney, N.S.W.	50.00	"	"
Anderson, J., 121 Newland St., Bondi Junction, N.S.W.	359.40	"	"
Dollimore, J., Department of Defence, Canberra, A.C.T.	166.00	"	25.2.85
Robilliard, P., Department of Defence, Canberra, A.C.T.	173.40	"	"

Companies Form 78, Sub-section 326 (1)
Registered No. 132727-M

Notice of Appointment of Receivers and Managers
of

E.G.A. STAINLESS STEEL PTY. LTD.

National Australia Bank Limited of 28th Floor, 500 Bourke Street, Melbourne gives notice that on 4 April 1986 it appointed Andrew Stewart Home and Geoffrey Noel Crawford-Fish, chartered accountants of Deloitte Haskins and Sells of 461 Bourke Street, Melbourne jointly and severally as receivers and managers of the property of the

Company specified in the Schedule under the powers contained in an instrument dated 24 September 1985 being a debenture registered number 54015.

Schedule

The whole of the undertaking and all the property and assets present and future of the Company whatsoever and wheresoever both present and future including the goodwill of its business and its uncalled and called but unpaid capital.

Dated 4 April 1986

Executed by National Australia Bank Limited by being signed sealed and delivered in Victoria by its

attorney James Richard Francis Williams under power of attorney dated 26 March 1986 who declares that he holds the office in the Bank indicated under his signature in the presence of:

Witness: G. R. TIBBALLS
2490 J. R. WILLIAMS, Chief Securities Officer

Companies (Victoria) Code
Section 411 (2)
GUNBOWER ESTATE PTY. LTD.
(in Liquidation)

Notice of Final Meeting

Notice is hereby given that pursuant to section 411 (2) of the Companies (Victoria) Code, a general meeting of members of Gunbower Estate Pty. Ltd. will be held at the offices of Messrs. Lockwood Partners, chartered accountants, 209 Hare Street, Echuca 3564 on 3 June 1986 at 3.00 p.m.

The purpose of the meeting is to lay accounts before it, showing the manner in which the winding up has been conducted and the property of the Company disposed of, and for hearing any explanation that may be given by the liquidator.

Dated 16 April 1986

P. J. JONES, Liquidator
LOCKWOOD PARTNERS, chartered
accountants, 209 Hare Street, Echuca, Vic. 2491

Companies (Victoria) Code
Sub-section 411 (2)
WORALLA HOLDINGS PTY. LTD. (In
Voluntary Liquidation)

Notice of Final Meeting

Notice is hereby given that pursuant to sub-section 411 of the Companies (Victoria) Code a final general meeting of the members of Woralla Holdings Pty. Ltd. will be held at 860 Glenferrie Road, Hawthorn on Thursday, 22 May 1986 at 10.15 a.m.

The purpose of the meeting is to lay accounts before it showing the manner in which the winding up has been conducted and the property of the company disposed of and of hearing any explanation that may be given by the liquidator.

Dated 14 April 1986

J. C. BENZIES Liquidator
J. C. Benzies, 860 Glenferrie Road, Hawthorn
3122 2506

Companies (Victoria) Code
Sub-section 411 (2)
WORALLA INVESTMENT CO. PTY LTD. (In
Voluntary Liquidation)

Notice of Final Meeting

Notice is hereby given that pursuant to sub-section 411 of the Companies (Victoria) Code a final general meeting of the members of Woralla Investment Co.

Pty. Ltd. will be held at 860 Glenferrie Road, Hawthorn on Thursday, 22 May 1986 at 10.00 a.m.

The purpose of the meeting is to lay accounts before it showing the manner in which the winding up has been conducted and the property of the company disposed of and of hearing any explanation that may be given by the liquidator.

Dated 14 April 1986

J. C. BENZIES Liquidator
J. C. Benzies, 860 Glenferrie Road, Hawthorn
3122 2507

Companies (Victoria) Code
Sub-section 411 (2)
OLGA GEIGER PTY. LTD. (In Voluntary
Liquidation)

Notice of Final Meeting

Notice is hereby given that pursuant to sub-section 411 of the Companies (Victoria) Code a final general meeting of the members of Olga Geiger Pty. Ltd. will be held at 860 Glenferrie Road, Hawthorn on Thursday, 22 May 1986 at 11.00 a.m.

The purpose of the meeting is to lay accounts before it showing the manner in which the winding up has been conducted and the property of the company disposed of and of hearing any explanation that may be given by the liquidator.

Dated 14 April 1986

J. C. BENZIES Liquidator
J. C. Benzies, 860 Glenferrie Road, Hawthorn
3122 2508

BRUNSWICK AND ESSENDON No. 2
CO-OPERATIVE HOUSING SOCIETY
LIMITED
(In Liquidation)

Take notice that the affairs of the above-named society are now fully wound up and that in pursuance of section 411 (1) of the Companies (Victoria) Code 1981 and of the *Co-operative Housing Societies Act* 1958, a General Meeting of the Society will be held at the Society's Office, 341 Collins Street, Melbourne, on 27 May 1986 at 5.30 p.m. for the purpose of—

- (i) laying before it an account showing how the winding up has been conducted and the property of the Society disposed of and giving any explanations thereof; and
- (ii) passing a resolution that the books and papers of the said Society and of the Liquidator relevant to the affairs of the Society be destroyed after a period of twelve months from the date of the meeting.

Dated 23 April 1986

H. C. HOLMES and B. R. HOPCROFT
2511 Joint/Neither Liquidators

Companies (Victoria) Code
Sub-section 411 (2)
CENTAUR PTY. LTD. (In Voluntary
Liquidation)

Notice of Final Meeting

Notice is hereby given that pursuant to sub-section 411 of the Companies (Victoria) Code a final general meeting of the members Centaur Pty. Ltd. will be held at 860 Glenferrie Road, Hawthorn on Thursday, 22 May 1986 at 10.30 a.m.

The purpose of the meeting is to lay accounts before it showing the manner in which the winding up has been conducted and the property of the company disposed of and of hearing any explanation that may be given by the liquidator.

Dated 14 April 1986

J. C. BENZIES Liquidator
J. C. Benzies, 860 Glenferrie Road, Hawthorn
3122 2510

GLEN IRIS AND DISTRICT No. 5
CO-OPERATIVE HOUSING SOCIETY
LIMITED

(In Liquidation)

Take notice that the affairs of the above-named Society are now fully wound up and that in pursuance of section 411 (1) of the Companies (Victoria) Code 1981 and of the *Co-operative Housing Societies Act* 1958, a General Meeting of the Society will be held at the Society's Office, 341 Collins Street, Melbourne, on 27 May 1986 at 5.30 p.m. for the purpose of—

- (i) laying before it an account showing how the winding up has been conducted and the property of the Society disposed of and giving any explanations thereof; and
- (ii) passing a resolution that the books and papers of the said Society and of the Liquidator relevant to the affairs of the Society be destroyed after a period of twelve months from the date of the meeting.

Dated 23 April 1986

H. C. HOLMES and B. R. HOPCROFT
2512 Joint/Either Liquidators

Companies (Victoria) Code
Sub-section 411 (2)
K. G. (LONDON) HOLDINGS PTY. LTD. (In
Voluntary Liquidation)

Notice of Final Meeting

Notice is hereby given that pursuant to sub-section 411 of the Companies (Victoria) Code a final general meeting of the members of K. G. (London) Holdings Pty. Ltd. will be held at 860 Glenferrie Road, Hawthorn on Thursday, 22 May 1986 at 10.45 a.m.

The purpose of the meeting is to lay accounts before it showing the manner in which the winding up has been conducted and the property of the

company disposed of and of hearing any explanation that may be given by the liquidator.

Dated 14 April 1986

J. C. BENZIES Liquidator
J. C. Benzies, 860 Glenferrie Road, Hawthorn
3122 2509

Creditors, next of kin and others having claims in respect of the estate of Mildred Elsie Paton, late of 700 Stedman Crescent, Albury, married woman, deceased, who died on 4 October 1985 are required by the executors William Andrew Thwaites, solicitor, of 416 Collins Street, Melbourne, Simon Fraser Paton, grazier of Bogong Ski Centre, Tawonga South and Catherine Elsie O'Brien, grazier of Mitta Park, RMB 1165, Tallangatta, to send particulars of their claims to them in care of the undermentioned solicitor by 30 June 1986 after which date they will distribute the assets having regard only to the claims of which they then have notice.

W. ANDREW THWAITES, solicitor, 10/416
Collins Street Melbourne 2493

RICHARD RAMSAY WEBB, late of Unit 3, 64
Kooyongkoot Road, Hawthorn, medical
practitioner, deceased

Creditors, next of kin and others having claims in respect of the estate of the deceased, who died on 27 February 1986, are required by The Perpetual Executors & Trustees Association of Australia Limited of 50 Queen Street, Melbourne and David James Hughes of 83 William Street, Melbourne, solicitor, the applicants for a grant of administration to send particulars of their claims to the said applicants in the care of the said company by 30 June 1986 after which date they will convey or distribute the assets having regard only to the claims of which they then have notice.

H. S. W. LAWSON HUGHES & CO., solicitors,
83 William Street, Melbourne 2494

WILFRED GILLMAN HALL, late of 21 Crest
Avenue, Balwyn in the State of Victoria, company
director, deceased

Creditors, next of kin and others having claims in respect of the estate of the deceased, who died on 4 February 1986, are required by the trustee, The Perpetual Executors & Trustees Association of Australia Ltd. of 50 Queen Street, Melbourne in the said State to send particulars to it by 21 June 1986, after which date the trustee may convey or distribute the assets, having regard only to the claims of which the trustee then has notice.

HALL & WILCOX, solicitors, 140 William Street,
Melbourne 2495

Creditors, next of kin and others having claims in respect of the estate of Lilian Jean Banks, late of 39 Ormond Avenue, Mitcham, married woman, who died on 22 September 1985, are to send

particulars of their claims to Valerie Joyce McMaster and Beverly Jean Reif, the executors, care of the undersigned by 13 June 1986, after which date they will commence to distribute the assets having regard only to the claims of which they then have notice.

RENNICK & GAYNOR, solicitors, 530 Little Collins Street, Melbourne, or 427 Riversdale Road, Hawthorn East 2496

MYRTLE ELIZABETH PAYNTER, late of 16 St Leonard's Court, South Yarra, widow, deceased

Creditors, next of kin and others having claims in respect of the estate of the said deceased who died on 17 January 1986 are to send particulars of their claims to the executor, The Equity Trustees Executors and Agency Company Limited of 472 Bourke Street, Melbourne by 26 June 1986 after which date it will distribute the assets having regard only to the claims of which it then has notice.

ARTHUR ROBINSON & HEDDERWICKS, solicitors, 535 Bourke Street, Melbourne 2497

RONALD GILBERT DAY, formerly of "Bellden Lodge", 383 Maroondah Highway, Croydon, but late of 391 Maroondah Highway, Croydon in the State of Victoria, retired electrical engineer, deceased

Creditors, next of kin and others having claims in respect of the estate of the abovenamed deceased who died on 19 February 1986 are required to send particulars thereof to the executor care of the undermentioned solicitors on or before 27 June 1986 after which date the executor may convey or distribute the assets having regard only to the claims of which he then has notice.

REES, BECKWITH & CO., solicitors, 118 Queen Street, Melbourne 2498

Creditors, next of kin and others having claims against the estate of Myrtle Eliza Dennison late of 1316 Toorak Road, Burwood in the State of Victoria, widow deceased who died on 28 November 1985 are required by the National Trustees Executors and Agency Company of Australasia Limited of 95 Queen Street, Melbourne in the said State to send particulars of their claims to the said company by 25 June 1986 after which date it will convey or distribute the assets having regard only to the claims of which the company then has notice.

TURNER, NESS & DAVIS, solicitors, 12 Batman Street, Melbourne 2499

ELMA HASTINGS KILGOUR, late of 3 Hardwicke Street, Balwyn in the State of Victoria, widow, deceased

Creditors, next of kin and others having claims in respect of the estate of the abovenamed deceased who died on 5 February 1986 are required to send particulars thereof to the executor care of the

undermentioned solicitors on or before 1 July 1986 after which date the executor may convey or distribute the assets having regard only to the claims of which he then has notice.

REES, BECKWITH & CO., solicitors, 118 Queen Street, Melbourne 2500

MARY CARMODY, late of 86 Nicholson Street, East Coburg in the State of Victoria, married woman, deceased

Creditors, next of kin and others having claims in respect of the estate of the abovenamed deceased who died on 4 January 1986 are required to send particulars thereof to the executor care of the undermentioned solicitors on or before 1 July 1986 after which date the executor may convey or distribute the assets having regard only to the claims of which he then has notice.

REES, BECKWITH & CO., solicitors, 118 Queen Street, Melbourne 2501

Creditors, next of kin and others having claims in respect of the estate of Eliza Ann Devitt formerly of Robinson Street, Thorpdale but late of Lot E Greenvale Drive, Gisborne, deceased who died on 19 January 1985 are required by the executors National Trustees Executors and Agency Company of Australasia Limited of 95 Queen Street, Melbourne in the State of Victoria and John Francis Britt, farmer of Copelands Road, Warragul in the said State to send particulars of their claims to the said executors care of the National Trustees Executors and Agency Company of Australasia Limited by 1 July 1986 after which date the said executors will convey or distribute the assets of the deceased having regard only to the claims of which the said executors then have notice.

MESSRS KEVIN DAVINE & SONS, solicitors, 1 Contingent Street, Trafalgar 2454

Creditors, next of kin and others having claims in respect of the estate of Mervyn Alan King late of 16 Stewart Street Brunswick, in the State of Victoria, gentleman, deceased, who died on 29 January 1986 are to send particulars of their claims to the executor Michael Sloey King care of the undermentioned solicitors by 23 June 1986 after which date the executor will distribute the assets having regard only to the claims of which he then has notice.

LE GRAND, RANGLES, ADAMS & CO., solicitors, 636 Sydney Road Brunswick 2455

Creditors, next of kin and all other persons having claims against the estate of Arthur Andrew Monkhouse late of 14 Greengully Estate, Greengully in the State of Victoria, gardener who died on 26 July 1985 are required by the Administrator Johann Arthur Lechner of 44 Havlin Street, West Bendigo in the State of Victoria, student to send particulars of their claims to him care of the undersigned

solicitors by 7 July 1986 after which date he may convey or distribute the assets having regard only to the claims of which he then has notice.

**COHENS, FRENKEL BERKOVITCH
KEFFORD & NEW**, solicitors, of 114 William
Street, Melbourne 2456

CAROLINE VERE JONAS, late of Mount Martha
Private Nursing Home, Mount Martha, widow,
deceased

Creditors, next of kin and others having claims in respect of the estate of the deceased (who died on 25 December 1985) are required by the Executors and Trustee Company Limited of 94 Queen Street Melbourne, to send particulars of their claims to the said Company by Monday, 30 June 1986, after which date it will convey or distribute the assets, having regard only to the claims of which the Company then has notice.

McCULLOUGH KOLLIAS & CO., solicitors, of
364 Main Street Mornington 2457

HARRIET JANE BUCKNALL, late of 177 Kent
Road, Hamilton in the State of Victoria, home
duties, deceased

Creditors, next of kin and others having claims in respect of the estate of the deceased who died on 6 November 1985 are required by the personal representative, the Union Fidelity Trustee Company of Australia Ltd, of 5 Doveton Street North Ballarat in the said State to send particulars to it by 25 June 1986 after which date the personal representative may convey or distribute the assets, having regard only to the claims of which it then has notice.

CUTHBERTS, solicitors, 101 Lydiard Street
North, Ballarat 2458

WILLIAM LYDNEY RICKARD, late of
Camperdown Road, Lismore, retired labourer,
deceased

Creditors, next of kin and others having claims in respect of the estate of the deceased, who died on 11 December 1985 are required by the trustee John Edgar Grills of 34 Hutcheson Avenue, Highton, retired farmer to send particulars to him care of the undermentioned solicitors by 30 June 1986 after which date the trustee may convey or distribute the assets, having regard only to the claims of which he then has notice.

ARTHUR E. GEORGE & SONS, solicitors, 202
Manifold Street, Camperdown 2451

IRENE BUNTON, late of 8 Robinson Street,
Murchison

Creditors, next of kin and others having claims in respect of the estate of the deceased who died on 3 September 1985 are required by the personal representative to send particulars to Messrs. P. V. Feltham & Co., solicitors of 16-18 Fryers Street,

Shepparton by 25 July 1986 after which date the personal representative may convey or distribute the assets, having regard only to the claims of which he then has notice.

Dated 16 April 1986 2452

BERTRAM ROBERT LACEY, late of "Larundel",
Plenty Road, Bundoora, gentleman, deceased

Creditors, next of kin and others having claims in respect of the estate of the abovenamed deceased, who died on 24 December 1985 are required to send particulars thereof to the executor of his will David Leonard Brooks care of the undermentioned solicitors, on or before 26 June 1986 after which date he will distribute the assets in the estate having regard only to the claims of which he shall then have notice.

J. M. SMITH & EMMERTON, solicitors, 385
Bourke Street, Melbourne 2453

GEORGE FRANKLIN PALMER, late of Flat 2, 6
Banyan Street, Warrnambool, in the State of
Victoria, retired, deceased

Creditors, next of kin and all others having claims in respect of the abovenamed deceased (who died on 23 December 1985) are required to send particulars of their claims in writing to the executrix Helen Reardon of Flat 4, 20 Richmond Avenue, Dee Why in the State of New South Wales care of the undersigned on or before 30 June 1986 after which date she will distribute the assets of the said Estate having regard only to the claims of which she then has notice as aforesaid.

DESMOND DUNNE & DWYER, solicitors,
Warrnambool 2511

JOSEPH ARUNDALE, late of 42 Park Street,
Seymour, retired, deceased

Creditors, next of kin and others having claims in respect of the estate of the deceased who died on 30 July 1985 are required by the trustees Robin Wesley Trewern and David Noel Trewern to send particulars of their claims to them care of the undersigned solicitors by 30 June 1986 after which date the trustees may convey or distribute the assets having regard only to the claims of which they then have notice.

GRAY, FRIEND & LONG, solicitors, Warragul
2515

MARTIN JOSEPH ESMOND, formerly of Mt.
Egerton, in the State of Victoria, farmer, but late
of 102 Ascot Street South, Ballarat, in the said
State, retired, deceased

Creditors, next of kin and others having claims in respect of the estate of the deceased, who died on 30 June 1985 are required by the executor Michael Sutton of 14 Dawson Street South, Ballarat, aforesaid to send particulars to him by 30 June

1986 after which date the executor may convey or distribute the assets, having regard only to the claims of which he then has notice.

CUTHBERTS, solicitors, 101 Lydiard Street
North, Ballarat 2516

Creditors, next of kin and other persons having claims in respect of the estate of Elsie May Thurling late of Unit 3, 6 Nelson Street, Ringwood, in the State of Victoria, widow who died on 14 September 1985 are required by the executors John David Moir and Anthony Felstead Smith both of 500 Collins Street, Melbourne in the said State to send particulars of the claims to them care of the undersigned by 24 June 1986 after which date they will convey or distribute the assets of the estate having regard only to the claims of which they then have notice.

GILLOTT'S, solicitors, 500 Collins Street,
Melbourne 2517

PETER JOHN KEEP, late of 5 Punari Court,
Seaford, Victoria, deceased, died on 8 September
1985

Any persons claiming to be dependent upon the deceased are requested to send particulars of their claims to Life Claims Department, Australian Eagle Insurance Company Limited, GPO Box 1883R, Melbourne 3001 within two months from the date of this notice, after which date the deceased's entitlement will be distributed in accordance with the provisions of the Eagle Retirement Fund Trust Deed having regard only to the claims which have been notified. 2476

ROY BROWN, late of 105 Ripon Street, Ballarat,
in the State of Victoria, retired farmer, deceased

Creditors, next of kin and others having claims in respect of the estate of the deceased, who died on 19 September 1985 are required by the personal representative, The Union-Fidelity Trustee Company of Australia Limited of 5 Doveton Street North, Ballarat, aforesaid to send particulars to it by 25 June 1986 after which date the personal representative may convey or distribute the assets, having regard only to the claims of which it then has notice.

CUTHBERTS, solicitors, 101 Lydiard Street
North, Ballarat 2477

MARY REEVE (also known as Mary Latch), late
of 148 Brunswick Road, Brunswick in the State
of Victoria, pensioner, deceased

Creditors, next of kin and all others having claims in respect of the estate of Mary Reeve (also known as Mary Latch), late of 148 Brunswick Road, Brunswick, pensioner, deceased, who died on 2 August 1985 are required by the executor Henry Charles Latch of 148 Brunswick Road, Brunswick

to send particulars of their claims to him in the care of the undermentioned solicitor prior to 30 June 1986 after which date he will distribute the assets having regard only to the claims of which he then has notice.

M. F. HUGHES, LL.B., solicitor, 300 Barkly
Street, Brunswick 2478

CYRIL EDWARD DEVANY, formerly of 27
Montclair Avenue, Brighton, but late of Villa
O'Neill Nursing Home, Lewisham Road, Prahran,
retired deceased

Creditors, next of kin and others having claims against the estate of the deceased, who died on 1 March 1986, are required by his executor, John Finlay Anderson of 43 Reserve Road, Beaumaris, to send particulars to him by 3 July 1986, after which date he will convey or distribute the assets having regard only to those claims of which he then has notice. 2479

ALFRED WALTER JARRETT, late of 25 River
Parade, Barwon Heads, retired poultry farmer,
deceased

Creditors, next of kin and others having claims in respect of the estate of the above deceased who died on 11 January 1986 are required by the personal representatives Richard Anthony Jarrett of 32 Culbara Drive Vermont manager and Geraldine Lesley Callister of 38 Salisbury Avenue Blackburn married woman to send particulars thereof to them care of the undermentioned solicitors by 30 June 1986 after which date the said personal representatives may convey or distribute the assets having regard only to the claims of which they then have notice.

Dated 16 April 1986

BRUHN & CO., solicitors, 32 Myers Street,
Geelong 2459

Creditors, next of kin and others having claims in respect of the estate of William Alan Coe late of 36 Springfield Road Blackburn in the State of Victoria retired deceased who died on 23 October 1985 are required to send particulars of their claims to the executor and executrix care of the undermentioned solicitors by 30 June 1986 after which date they will distribute the assets having regard only to the claims for which notice has been received.

BORCHARD & MOORE, solicitors, of 44
Douglas Street, Noble Park 2513

Creditors, next of kin and others having claims against the estate of Catherine McMahon late of Karinya Nursing Home, 32 Kangerong Road, Box Hill, who died on 12 October 1985 are to send particulars of their claims to the Executor, National Trustees Executors and Agency Company of Australasia Limited of 95 Queen Street, Melbourne

before 18 June 1986 after which date it will distribute the assets of the estate having regard to the claims only of which it then has notice.

JOHN F. CARROLL, solicitor, of 95 Queen Street, Melbourne 2447

Creditors, next of kin and others having claims against the estate of James Thomas Lyell Heron late of 14 Athol Street, Prahran in the State of Victoria, pensioner, deceased, who died on 21 June 1985 are to send particulars of their claims to Glenn Martin Heron the administrator of the estate of the said deceased care of the undersigned solicitor before 18 June 1986 after which date he will distribute the assets of the estate having regard only to the claims for which he then has notice.

JOHN F. CARROLL, solicitor, of 95 Queen Street, Melbourne 2448

Creditors, next of kin or others having claims in respect of the estate of Evelyn Eymmer late of 143 Boundary Road Dromana, widow, deceased, who died on 27 November 1985 are to send particulars of their claims to the executors care of the undermentioned solicitors by 18 June 1986 after which date the executors will distribute the assets having regard only to the claims of which they then have notice.

WRIGHT SMITHS, solicitors, 13 Rosebud Parade, Rosebud 2449

BARTOLO FRAZZETTO, late of 408 Edgars Road, Lalor, in the State of Victoria, pensioner, deceased

Creditors, next of kin and others having claims in respect of the estate of the deceased who died on 8 November 1984, are required by the administrator, Paul Frazzetto, care of Arthur J. Dines & Co., solicitors of 2A Highlands Road, Thomastown, in the said State, to send particulars to him by 30 June 1986, after which date the administrator may convey or distribute the assets having regard only to claims of which he then has notice.

Dated 16 April 1986

ARTHUR J. DINES & Co., solicitors of 2A Highlands Road, Thomastown 2480

Creditors, next of kin and others having claims in respect of the estate of Raymond Arnold Keith Davis late of 56 Willis Street, Winchelsea, cartage contractor deceased who died on 2 March 1985 are required to send particulars of their claims to the executors Lois Davis and Raymond John Davis care of the undersigned solicitors before 25 June 1986 after which date the assets of the estate will be distributed having regard only to the claims of which the executors then have notice.

HARWOOD & PINCOTT, solicitors, 77 Moorabool Street, Geelong 2481

GEORGE ISABEL BELL (also known as George Isabel Cranston), late of 85 North Street, Ascot Vale

Creditors, next of kin and others having claims in respect of the estate of the abovenamed deceased who died on 24 February 1986 are to send particulars of their claims to the executor Nicholas James Galante care of the undermentioned solicitors by 30 June 1986 after which date the said executor will distribute the assets having regard only to the claims of which he then has notice.

O'BRIEN & GALANTE, solicitors, 27 Norwood Crescent, Moonee Ponds 2482

KEVIN ROYAL BAXTER, late of 252 North Road, Brighton East, accountant, deceased

Creditors, next of kin and others having claims against the estate of the said deceased who died on 25 October 1985 are to send particulars of their claims to Ivy Baxter c/o Messrs. Blake & Riggall, solicitors, 140 William Street Melbourne by 16 July 1986 after which date she will distribute the assets having regard only to the claims of which she then has notice.

BLAKE & RIGGALL, solicitors, 140 William Street Melbourne 2492

In the Supreme Court of the State of Victoria
SALE BY THE SHERIFF

On 5 June 1986 at 2.30 p.m. at the Sheriff's Office, Writs and Warrants Division, 287 Springvale Road, Glen Waverley (unless process be stayed or satisfied).

All the estate and interest (if any) in and to the following:

Joseph Milian of 139 Kings Road, St Albans as joint proprietor with Dasa Milian of an estate in fee simple in the land described in Certificate of Title Volume 9068 Folio 370 upon which is erected a dwelling and known as No. 139 Kings Road, St Albans.

Registered Mortgage Nos. G402384 and J303346.

Mr and Mrs H. Selimovic of 31 Elizabeth Street, Westmeadows shown on Certificate of Title as Husein Selimovic and Maria Selimovic joint proprietors of an estate in fee simple in the land described in the Certificate of Title Volume 9506 Folio 785 upon which is erected a dwelling and known as 31 Elizabeth Street, Westmeadows.

Registered Mortgage L526546U and Caveat L117859A.

Ronald William Byron of 20 Arawata Parade, Melton joint proprietor with Margery Florence Byron of an estate in fee simple in the land described in the Certificate of Title Volume 8450 Folio 464 upon which is erected a dwelling and known as 20 Arawata Parade, Melton.

Registered Mortgage F977426.

Jennifer Marice Edwards of 1 Caroline Street, Selby joint proprietor with Craig William Edwards of an estate in fee simple in the land described in the Certificate of Title Volume 8931 Folio 850 upon which is erected a dwelling and known as 1 Caroline Street, Selby.

Registered Mortgages K56798, K503491 and Caveat L925386K.

Any mortgages and/or other dealings specified may affect the said estate and interest.

Terms—Cash only

2522 A. STANLEY, Sheriff's Officer

In the Supreme Court of the State of Victoria
SALE BY THE SHERIFF

On 29 May 1986 at 2.30 p.m. at the Sheriff's Office, 287 Springvale Road, Glen Waverley (unless process be stayed or satisfied).

All the estate and interest (if any) of Judith Exell of 40 Coppin Street, East Malvern shown on Certificate of Title as Judith Ann Cristina, proprietor of an estate in fee simple in the land described in Certificate of Title Volume 8874 Folio 798 upon which is erected a dwelling and known as 5 Tollington Avenue, East Malvern.

Registered Caveats H400662, H803559, J96150, L809634U, L888020Q affect the said estate and interest.

Terms—Cash only

2520 A. STANLEY, Sheriff's Officer

In the Supreme Court of the State of Victoria
SALE BY THE SHERIFF

On 29 May 1986 at 2.30 p.m. at the Sheriff's Office, 287 Springvale Road, Glen Waverley (unless process be stayed or satisfied).

All the estate and interest (if any) of David Pluckrose of 50 Florence Drive, Rye shown on Certificate of Title as David William Pluckrose joint proprietor with Suzanne Denise Pluckrose of an estate in fee simple in the land described in the Certificate of Title Volume 8583 Folio 931 upon which is erected a dwelling and known as 50 Florence Drive, Rye.

Registered Mortgage L706134A affects the said estate and interest.

Terms—Cash only

2521 A. STANLEY, Sheriff's Officer

NOTICE OF MAKING OF STATUTORY RULES WHICH ARE NOT YET AVAILABLE

Notice is given of the making of the following Statutory Rules:

No. *Supreme Court Act 1958*
99/1986 General Rules of Procedure in Civil Proceedings 1986

NOTICE OF MAKING AND AVAILABILITY OF STATUTORY RULES

In pursuance of the provisions of the *Subordinate Legislation Act 1962* and the Regulations made thereunder notice is given of the making and availability of the following Statutory Rules:

Note: The date specified after each Statutory Rule is the date it was first obtainable from the Victorian Government Bookshop, 41 St Andrew's Place, East Melbourne.

No.	Statutory Rule	Price
69/1986	<i>Teaching Service Act 1981</i> Teaching Service (Appeals Boards, Chairman—Remuneration) (Amendment No. 19) Regulations 1986	
4 April 1986		40c
70/1986	<i>Public Service Act 1974</i> Public Service (Amendment) Regulations (No. 2) 1986	
16 April 1986		40c
72/1986	<i>Estate Agents Act 1980</i> Estate Agents (Licensing, General, Accounts and Audit) (Amendment) Regulations 1986	
17 April 1986		70c
77/1986	<i>Magistrates' Courts Act 1971</i> <i>Magistrates (Summary Proceedings) Act 1975</i> Magistrates' Courts (Penalty Enforcement by Registration of Infringement Notices) Rules 1986	
17 April 1986		90c
83/1986	<i>Police Regulation Act 1958</i> Police (Amendment) Regulations 1986	
21 April 1986		90c

<i>Optometrist Registration Act 1958</i>		<i>Schedule Number</i>	<i>Item Number</i>	<i>New Rate</i>	<i>Effective Date</i>
89/1986	Optometrists (Qualifications) Regulations 1986			\$	
17 April 1986		40c	<i>Optional Equipment—Automatic Transmission</i>	667.50	
90/1986	<i>Dietitians Act 1981</i> Dietitians (Amendment) Regulations 1986		C	8 090.75	
16 April 1986		40c	<i>Optional Equipment—Automatic Transmission</i>	567.00	
			1/59A (4) A	6 676.25	
			<i>Optional Equipment—Automatic Transmission</i>	671.25	
			C	7 732.25	
			<i>Optional Equipment—Automatic Transmission</i>	568.50	
			1/59A (5) A	8 174.00	
			C	9 124.25	
			1/59B (2) A	6 584.50	
			1/59B (3) A	8 003.00	2.4.86
			B	8 018.96	8.4.86
			<i>Optional Equipment—Automatic Transmission</i>	953.12	
			D	9400.54	
			<i>Optional Equipment—Automatic Transmission</i>	649.72	
			1/59B (4) A	9 271.00	2.4.86
			B	9 071.98	8.4.86
			<i>Optional Equipment—Automatic Transmission</i>	646.02	
			C	10 062.84	
			<i>Optional Equipment—Automatic Transmission</i>	645.28	
			1/59c (1) B	9 679.04	
			D	10 540.12	
			1/59c (2) D	10 065.12	
			1/59c (3) A	11 068.65	
			B	11 897.94	
			1/59c (5) A	13 840.04	
			1/59c (6) A	11 669.48	
			B	13 409.88	
			1/59c (7) A	15 424.54	
			B	17 230.96	
			1/59D (1) A	11 579.80	
			B	12 617.96	
			1/59D (2) A	19 560.56	

LATE NOTICES

**STATE TENDER BOARD
CONTRACTS ACCEPTED
AMENDMENTS**

<i>Schedule Number</i>	<i>Item Number</i>	<i>New Rate</i>	<i>Effective Date</i>
		\$	
<i>Paints and Painters' Sundries</i>			
1/12	100	0.87	15.4.86
	101	1.76	
	102	1.24	
<i>Motor Spirit—State Petrol Centre</i>			
1/53A	1	0.4080	17.4.86
	2	0.4036	
<i>Motor Spirit, Kerosene, Fuel Oils and Lubricants</i>			
1/53B	1	0.4070	17.4.86
	2	0.4169	
	5	0.4114	
	6	0.4213	
	7	0.4740	
	8	0.4640	
	10	0.4446	
	12	0.4501	
	14	0.4418	
	16	0.4468	
	17	0.4423	
	18	0.4423	
	26	0.4026	
	27	0.4101	
	28	0.4678	
	29	0.4628	
<i>Hand Tools</i>			
1/56	283	1.62	11.3.86
<i>Light Commercial Motor Vehicles</i>			
1/59A (2)	A	7849.25	8.4.86
<i>Optional Equipment—Automatic Transmission</i>			
1/59A (3)	A	7 028.75	

Schedule Number	Item Number	New Rate	Effective Date
			\$
<i>Calculators, Electronic</i>			
1/71	2	*	
* Delete : Citron Australia Holdings Pty. Ltd. Add : Purchase (Regulation 84)			
<i>Provisions—Melbourne and Metropolitan District</i>			
2/01	54	7.87	28.4.86
	56	4.06	26.3.86
	58	19.52	
	113	10.38 *	22.3.86
	114	19.40	
	115	14.71	
	116	19.40	
* Delete : 24 tins per ctn. Add : 12 tins per ctn.			
<i>Light Aircraft Charter Service</i>			
4/01	Citation Jet	1 210.00	4.4.86
	Piper Cheyenne	632.50	
	Beechcraft	396.00	
	Chancellor	396.00	
	Piper Aztec	269.50	
	Cessna 340	291.50	
	Seneca II	269.50	
	Partenavia 68T	225.50	

J. M. PAWSON
Secretary to the Tender Board

Transport Act 1983

DECLARATION OF ROADS BY THE MINISTER FOR TRANSPORT

The Minister for Transport for the State of Victoria declares the roads or parts of roads or any deviations from or widenings of roads as described below:

State Highways

- 18/86 Declaration of the widenings of the Midland Highway in the Shire of Buninyong as shown hatched on plan numbered GP 16386B hereunder.
- 19/86 Declaration of the widenings of the Western Highway in the Shire of Stawell as shown hatched on plans numbered GP 15516D, GP 15516F, GP 15517B, GP 15518B, and GP 15519B hereunder.

Main Roads

- 20/86 Declaration of the widening of the Letts Beach-Rosedale Road in the Shire of Rosedale as shown hatched on plan numbered GP 16541B hereunder.
- 21/86 Declaration of the widening of the Cobden-Scotts Creek Road in the Shire of Heytesbury as shown hatched on plan number GP 16604B hereunder.

22/86 Declaration of the widening of the Penshurst-Warrnambool Road in the Shire of Warrnambool as shown hatched on plan numbered GP 16579B hereunder.

23/86 Declaration of the widening of the Stawell-Pomonal Road in the Township of Stawell as shown hatched on plan numbered GP 16294B hereunder.

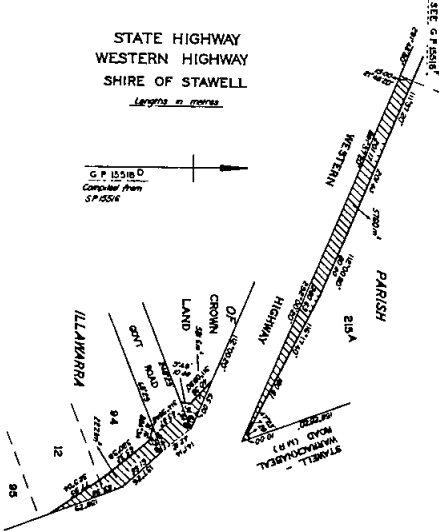
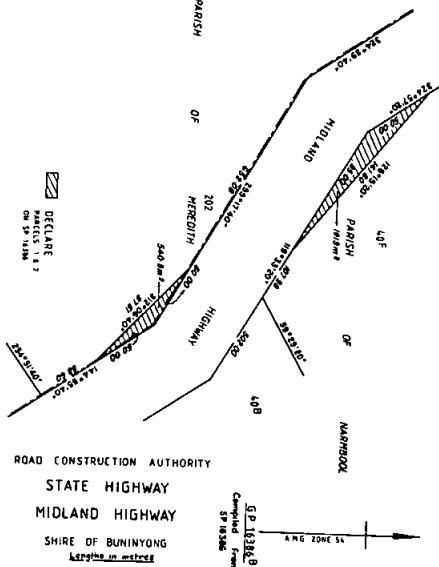

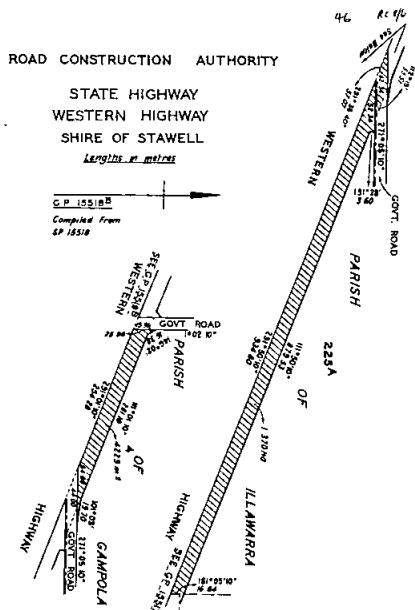

Dated 18 April 1986

TOM ROPER
Minister for Transport

DEPARTMENT OF MANAGEMENT AND BUDGET

Notice under Section 59A (2A) of the *Stamps Act* 1958

His Excellency the Governor of the State of Victoria, by and with the advice of the Executive Council thereof on 16 April 1986 hereby declares the *Stamp Duties Act* 1920 of the State of New South Wales to be a corresponding law for the purposes of section 59A of the *Stamps Act* 1958.

And the Honourable Robert Allen Jolly, Her Majesty's Treasurer for the State of Victoria, shall give the necessary directions herein accordingly.

L. G. HOUSTON
Clerk of the Executive Council

DEPARTMENT OF MANAGEMENT AND BUDGET

Notice under Section 59A (2A) of the *Stamps Act* 1958

His Excellency the Governor of the State of Victoria, by and with the advice of the Executive Council thereof on 16 April 1986 hereby declares the *Stamp Act* 1894 of the State of Queensland to

be a corresponding law for the purposes of section 59A of the *Stamps Act* 1958.

And the Honourable Robert Allen Jolly, Her Majesty's Treasurer for the State of Victoria, shall give the necessary directions herein accordingly.

L. G. HOUSTON
Clerk of the Executive Council

Local Government Act 1958

PART OF ROAD NOT REQUIRED FOR PUBLIC TRAFFIC—TOWN OF STAWELL

Pursuant to the provisions of section 533 (2) of the *Local Government Act* 1958 notice is hereby given that the Council of the Town of Stawell and the Minister for Local Government have decided that part of Skene Street, Stawell, as shown by hatching on the plan hereunder is not required for public traffic.

PROPOSED ROAD CLOSURE
SKENE STREET
PARISH OF STAWELL
COUNTY OF BORLUG
SCALE 1:200

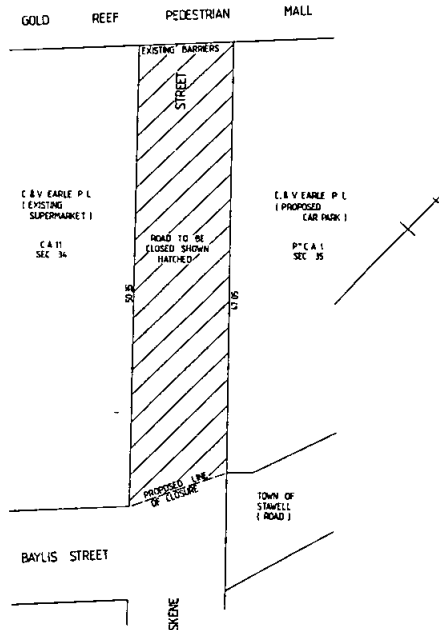

Local Government Department
Melbourne (86/0048)

*Building Control Act 1981***BUILDING CONTROL ACCREDITATION
AUTHORITY**

Pursuant to Part V of the *Building Control Act 1981* a Certificate of Accreditation (Number V85/13) has been issued to Brugger Exports Ltd. of Petone, New Zealand for the accreditation of the installation method for the Schooner Models 500 and 700 free standing wood burners with regard to—

- (a) distance between side and rear surfaces of the unit and a combustible part of the building;
- (b) distance between the flue below ceiling level and a combustible part of the building;
- (c) extent of hearth—

the Building Control Accreditation Authority has determined that the design for installation with respect to distances between the unit together with its flue and combustible parts of the building and the extent of the hearth complies with the requirements of Regulation 25.4 of the Victoria Building Regulations subject to those conditions of use and identification details contained in the said certificate.

E. KAROL
Registrar

*Building Control Act 1981***BUILDING CONTROL ACCREDITATION
AUTHORITY**

Pursuant to Part V of the *Building Control Act 1981* a Certificate of Accreditation (Number V86/01) has been issued to Cook-on-Gas Products Pty. Ltd. of 327 Chisholm Road, Auburn, N.S.W. for the accreditation of the installation method for the Maxitile wood-burning heater with regard to distance between the heater and a combustible surface the Building Control Accreditation Authority has determined that the design for installation with respect to distance between the rear of the appliance and a combustible surface complies with the requirements of Regulation 25.4 of the Victoria Building Regulations subject to those conditions of use and identification details contained in the said certificate.

E. KAROL
Registrar

*Building Control Act 1981***BUILDING CONTROL ACCREDITATION
AUTHORITY**

Pursuant to Part V of the *Building Control Act 1981* a Certificate of Accreditation (Number V85/11) has been issued to Hesbia Pty. Ltd. of 4-6 Lincoln Street, East Brunswick, Victoria for the accreditation of the method of design using the permissible load tables and method of construction consisting of galvanized mild steel tension bars, connection plates and end stops laid in the mortar

bed over the first course of bricks over an opening for the Hesbia brick reinforcement system the Building Control Accreditation Authority has determined that the method of design and construction complies with the requirements of Regulation 43.1 of the Victoria Building Regulations subject to those conditions of use and identification details contained in the said certificate.

E. KAROL
Registrar

*Building Control Act 1981***BUILDING CONTROL ACCREDITATION
AUTHORITY**

Pursuant to Part V of the *Building Control Act 1981* a Certificate of Accreditation (Number V86/03) has been issued to Triangle Building Products Pty. Ltd. of 10 Elizabeth Street, Kensington, Victoria for the accreditation of Triangle Kwik-Brik simulated brick hearth and wall heat shield system the Building Control Accreditation Authority has determined that the design and material when used with an enclosed domestic-type fuel burning appliance complies with the requirements of Regulation 25.4 of the Victoria Building Regulations subject to those conditions of use and identification details contained in the said certificate.

E. KAROL
Registrar

*Building Control Act 1981***BUILDING CONTROL ACCREDITATION
AUTHORITY**

Pursuant to Part V of the *Building Control Act 1981* a Certificate of Accreditation (Number V86/02) has been issued to Barbeques Galore Pty. Ltd. of 327 Chisholm Road, Auburn, N.S.W. for the accreditation of the installation method for the Norseman Tile wood-burning heater with regard to distance between the heater and a combustible surface the Building Control Accreditation Authority has determined that the design for installation with respect to distance between the rear of the appliance and a combustible surface complies with the requirements of Regulation 25.4 of the Victoria Building Regulations subject to those conditions of use and identification details contained in the said certificate.

E. KAROL
Registrar

*Building Control Act 1981***BUILDING CONTROL ACCREDITATION
AUTHORITY**

Pursuant to Part V of the *Building Control Act 1981* a Certificate of Accreditation (Number V85/10) has been issued to Lavec Sales and Service of 1001 Highlands Road, Seymour, Victoria for the accreditation of the installation method for the Warmbrite III wood-burning heater with regard to

distance between the rear of the appliance and a combustible surface the Building Control Accreditation Authority has determined that the design for installation with respect to distance between rear of appliance and a combustible surface complies with the requirements of Regulation 25.4 of the Victoria Building Regulations subject to those conditions of use and identification details contained in the said certificate.

E. KAROL
Registrar

ADOPTION ACT 1984

Pursuant to section 5 of the Adoption Act, the manager of Adoption Section, Delegate of the Director-General of Community Services has approved the following persons as Counsellors:

Mercy Maternity Hospital
Social Work Section
Clarendon Street
East Melbourne 3002
ERVIN, Sharene Lea
WINSTON, Megan Evans
NEWTON, Mary Jacinta

Dated 16 April 1986

LYNN GRAY, Manager
Adoption Section

ADOPTION ACT 1984

Pursuant to section 5 of the *Adoption Act* 1984, the Manager of Adoption Section, Delegate of the Director-General of Community Services has revoked the approval of the following persons as Counsellors:

PYE, Vivienne Janet Elizabeth
Mission of St. James & St. John
8 Batman Street
West Melbourne 3003
WEBSTER, Marilyn
Royal Women's Hospital
Social Work Department
132 Grattan Street
Carlton 3053
HADWIN, Diane Margaret
Mercy Maternity Hospital
Clarendon Street
East Melbourne 3002

Dated 16 April 1986

LYNN GRAY, Manager
Adoption Section

Transport Act 1983

ROAD TRAFFIC AUTHORITY

Commercial Passenger Vehicle Applications

Notice is hereby given that the following applications will be considered by the Road Traffic Authority on 13 May 1986.

Notice of any objections should be forwarded to reach the Manager, Vehicle Licensing Branch or any Regional Office of the Road Traffic Authority not later than 7 May 1986.

It will not be necessary for interested parties to appear on the hearing date specified, unless advised in writing by the Authority.

Notification of the date for consideration of applications which are objected to and which require determination by the Road Transport Licensing Tribunal will be published by further notice in this *Gazette*.

Budget Rent a Car System Pty. Ltd. North Melbourne—Application to license ten commercial passenger vehicles in respect of 1985–86 Jaguar XJ6 saloons each with a seating capacity for 4 passengers to operate as metropolitan hire cars from 188 Peel Street, North Melbourne.

Note: This application is to replace ten metropolitan hire car licences granted by the Road Transport Licensing Tribunal on 7 February 1985 in respect of 1985 Mercedes Benz 380 SEL saloons.

A. G. & M. R. Campe, Hamilton—Application to license one commercial passenger vehicle with seating capacity for 41 passengers to operate under charter conditions from within a 20 km pick-up radius of the post office at Hamilton.

Note:

(i) The vehicle to be licensed holds a 2 star rating for charter purposes; and

(ii) The vehicle to be licensed currently operates in substitution for but not in addition to existing TS licensed vehicles.

R. A. & E. F. Malcolm, Churchill—Application for variation of the conditions of licence CH 444 which authorizes hire car operations from 120 Maryvale Road, Morwell to change the operational address to Switchback Road, Churchill or from other premises in Churchill approved by the Road Traffic Authority.

Dated 23 April 1986

G. J. MENARY
Group Manager
Licensing and Research

Land Act 1958

Section 134

APPLICATION FOR LEASE

Notice is hereby given that application has been made to the Department of Conservation, Forests and Lands pursuant to section 24 of the State Electricity Commission Act and section 134 of the *Land Act* 1958 for lease of Crown allotment 4, section 17, Township of Mallacoota, for a term of 21 years, for the purpose of a base depot.

L. R. FOSTER, Secretary
State Electricity Commission of Victoria

ERRATUM

Town and Country Planning Act 1961

CITY OF BENALLA PLANNING SCHEME

The scheme that allows the rezoning of a small parcel of land on the north-east corner of Ackerly Avenue and Arundel Street, Benalla from Rural to Residential A appeared in *Government Gazette* No. 24 of 16 April 1986 on page 906 as "City of Benalla Planning Scheme Amendment No. 40". This should have been shown as "Amendment No. 41".

Country Fire Authority Act 1958

VARIATION OF FIRE DANGER PERIOD

In pursuance of the powers conferred by section 4 of the *Country Fire Authority Act 1958*, I, Charles Race Thorson Mathews, Minister for Police and Emergency Services, after consultation with the Minister for Conservation, Forests and Lands hereby vary the declaration of fire danger periods previously published in the *Government Gazette* by declaring that such fire danger periods shall end in respect of the undermentioned municipalities or parts of municipalities specified:

From and inclusive of Thursday 24 April 1986.

Shire of Alexandra, Shire of Broadford, Shire of Melvor, Shire of Pyalong, Shire of Seymour, Shire of Yea, Shire of Kilmore, Shire of Bacchus Marsh, Shire of Gisborne, Shire of Melton, Shire of Newham and Woodend, Shire of Romsey, City of Keilor (those portions not included in Metropolitan Fire District), Shire of Bulla (those portions not included in Metropolitan Fire District), Shire of Werribee (those portions not included in Metropolitan Fire District), Shire of Whittlesea (those portions not included in Metropolitan Fire District), City of Geelong, City of Geelong West, City of Newtown, City of South Barwon, Shire of Barrabool, Shire of Bellarine, Shire of Corio, Borough of Queenscliffe, Shire of Bannockburn, Shire of Leigh, Shire of Winchelsea, Shire of Yackandandah, City of Benalla, Shire of Benalla, Shire of Mansfield, Shire of Oxley, Rural City of Wodonga, Shire of Beechworth, Shire of Bright, Shire of Chiltern, Shire of Myrtleford, Shire of Tallangatta, Shire of Upper Murray;

From and inclusive of Saturday, 26 April 1986

City of Ballarat, Shire of Grenville, Shire of Bungaree, City of Maryborough, Shire of Creswick, Shire of Kyneton, Shire of Newstead, Shire of Avoca, Shire of Ararat, Shire of Ripon, Borough of Sebastopol, Shire of Ballarat, Shire of Buninyong, Shire of Ballan, Shire of Daylesford and Glenlyon, Shire of Talbot and Clunes, Shire of Tullaroop, City of Ararat, Shire of Lexton, Shire of Metcalfe;

From and inclusive of Thursday, 1 May 1986

City of Portland, Shire of Portland, City of Hamilton, City of Warrnambool, Borough of Port Fairy, Shire of Mortlake, Shire of Warrnambool, Shire of Glenelg, Shire of Wannon, Shire of Belfast, Shire of Dundas, Shire of Minhamite, Shire of Mount Rouse.

C. R. T. MATHEWS

Minister for Police and Emergency Services
Ministry for Police and Emergency Services
Melbourne, 22 April 1986

CORRIGENDUM

*Water Act 1958*RURAL WATER COMMISSION OF
VICTORIAMORNINGTON PENINSULA URBAN
DISTRICT

In *Government Gazette* No. 125 of 18 December 1985 on page 4701 concerning the notice to owners of tenements with reference to Ellery Street, Hastings, the description should read "From Frankston/Flinders Road to a point opposite Lot 2 about 71 metres easterly".

In *Government Gazette* No. 2 of 8 January 1986 on pages 60 to 64—

with reference to Blairgowrie, "Old Melbourne Road" should read "Melbourne Road";

with reference to Frankston, "Bodella Court" should read "Bodalla Court";

with reference to Mt. Martha, "Lot 354" should read "Lot 355";

with reference to Seaford, "Rickson Court" should read "Nickson Street";

with reference to Sorrento, "Parkside Road" should read "Parkside Street".

PROPOSED REVOCATION OF TEMPORARY
RESERVATION OF LAND BY ORDER IN
COUNCIL

In pursuance of the provisions of section 10 of the *Crown Land (Reserves) Act 1978*, notice is hereby given that it is the intention of the Governor in Council to revoke the temporary reservation of land by Order in Council hereunder referred to, viz:

Baynton—The temporary reservation by Order in Council of 24 February 1885 of 40.46 hectares of land in the Parish of Baynton as a site for road and watering purposes.

Lancefield—The temporary reservation by Order in Council of 21 October 1867 of 7664 square metres of land in the Township of Lancefield as a site for police purposes so far only as the portion containing 1350 square metres as shown on Certified Plan No. 107662 lodged in the Central Plan Office.

J. E. KIRNER

Minister for Conservation, Forests and Lands

Town and Country Planning Act 1961
**MELBOURNE METROPOLITAN PLANNING
 SCHEME**

**Notice of Execution of Instrument of Variation of
 Delegation**

Notice is hereby given that the Minister for Planning and Environment in respect to the Melbourne Metropolitan Planning Scheme has executed an instrument of variation of delegation dated 2 April 1986 varying the delegation to the City of Box Hill of powers, authorities and responsibilities in respect of the said Scheme delegated by instrument of delegation executed on 4 October 1985.

The variation of delegation shall have force and effect from the date of publication of this notice.

Copies of the instrument of variation of delegation may be inspected during office hours at the office of the Ministry for Planning and Environment and the office of the City of Box Hill at Box Hill.

DAVID YENCKEN
 Secretary for Planning and Environment

Department of Industry, Technology and
 Resources

INTENTION TO RENEW A MINING LEASE

No. 193-1; A. R. Freeman, Executor for the Estate of the Late R. W. Bennett and W. J. Bennett; 56.242 ha, Parish of Piangil West.

VARIATION OF MINING LEASE COVENANT

No. 9275; Charlies Hope NL; the labour covenant is varied from eight to three men, effective from 27 March 1986.

**INTENTION TO GRANT DEVELOPMENT
 LEASES**

No. 50; C. R. Jardine; approximately 180 ha, Parishes of Tarnagulla and Waanyarra.

No. 51; C. R. Jardine; approximately 140 ha, Parish of Gladstone.

**APPLICATION FOR DEVELOPMENT LEASE
 REFUSED**

No. 298; Kimak Pty. Ltd.; 1 ha, Parish of Blackwood.

**INTENTION TO GRANT PROSPECTING
 AREA LICENCE**

No. 56; Amber Gem Pty. Ltd.; 62 ha, Parish of Drummond.

PROSPECTING AREA LICENCE GRANTED

No. 7; Alan E. Dickerson; 11 ha, Parish of Wedderburn.

**APPLICATION FOR PROSPECTING AREA
 LICENCE WITHDRAWN**

No. 103; Kempson Tunbridge Mining Pty. Ltd.; approximately 167 ha, Parish of Whirrakee.

**INTENTION TO GRANT A MINING AREA
 LICENCE**

No. 16; Peter Dean Gardner; 2.721 ha, Parish of Yambulla.

TAILINGS REMOVAL LICENCE GRANTED

No. 5145; Shire of Newstead, to remove tailings from "Frenchman's Mine Dump" situated at Campbells Creek in the Parish of Castlemaine.

**APPLICATION FOR TAILINGS TREATMENT
 LICENCE REFUSED**

No. 283; Western Gulf Oil and Mining Ltd.; 82 ha, Parish of Costerfield.

**EXPLORATION LICENCES GRANTED AND
 AREAS REFUSED**

No. 1553; Nickleseekers Ltd.; area retained 75.75 km², area refused nil, County of Bogong.

No. 1594; Miners Rest Hotel/Motel Pty. Ltd.; area retained 48.25 km², area refused 0.75 km², County of Talbot.

No. 1595; Technical World Ltd.; area retained 5.75 km², area refused 0.25 km², County of Croajingolong.

No. 1605; Pan Australia Mining Ltd.; area retained 13 km², area refused nil, County of Benambra.

**APPLICATIONS FOR EXPLORATION
 LICENCES REFUSED**

Nos. 1573 to 1588 inclusive; CRA Exploration Pty. Ltd.; 7629 km², County of Mildura.

**APPLICATION FOR EXTENSION OF
 EXPLORATION LICENCE REFUSED**

No. 1441-1; Southern Continental Mining Ltd.; 91.75 km², County of Croajingolong.

**APPLICATION FOR EXPLORATION
 LICENCE WITHDRAWN**

No. 1612; P. J. Gillard and M. M. Robinson; 61 km², County of Bogong.

**EXTRACTIVE INDUSTRY LICENCE
 GRANTED**

No. 988; Cheryl G. Bartlett, Craig T. Bartlett and Paul R. Bartlett; 2 ha, Parish of Belfast.

**APPLICATION FOR EXTRACTIVE
 INDUSTRY LICENCE DECLARED
 ABANDONED**

No. 1250; Herman Rafael; 11 ha, Parish of Orbost East.

**APPLICATION FOR RENEWAL OF
 EXTRACTIVE INDUSTRY LICENCE
 REFUSED**

No. 968; Shire of Kerang; 21.8136 ha, Parish of Gnarwee.

**EXTRACTIVE INDUSTRY LEASES
 GRANTED**

No. 325; D. J. Rixon; 5.680 ha, Parish of Castlemaine.

No. 271; Shires of Barrabool and Winchelsea; 26-99 ha, Parish of Gherang Gherang.

R. C. FORDHAM
Minister for Industry, Technology and Resources

Liquor Control Act 1968

**APPOINTMENT OF LICENSING
INSPECTORS**

In accordance with the authority conferred upon me by section 6 of the *Police Regulation Act 1958*, I, Eric Archibald Mudge, Deputy Commissioner of Police, do hereby appoint under sub-section (1) of section 22 of the *Liquor Control Act 1968*, the following Officers of Police as Licensing Inspectors for the Divisions of the Police Districts as shown:

<i>Division Number</i>	<i>Police District</i>	<i>Name and Rank</i>
1	Gippsland	Inspector Norman Melrose Cohen Wilde, 13286 (<i>Vice</i> Chief Inspector Donald Frank Flowers, 12308)
4	Maroondah	Inspector Alexander McBain Wallace, 13024 (from 23.3.86 to 3.5.86)
4	Maroondah	Inspector William Michael Reddy, 14503 (from 4.5.86 to 31.5.86)

Dated 18 April 1986

E. A. MUDGE
Deputy Commissioner (Administration)

NURSES ACT 1958

Notice is hereby given in pursuance of the *Nurses Act 1958* and Regulations thereunder that an election will be held on 27 August 1986, for the appointment as members of the Victorian Nursing Council of—

- six registered general nurses
- one registered midwife,
- one registered psychiatric nurse or mental retardation nurse
- one registered mothercraft nurse and
- two registered State enrolled nurses

Persons nominated for election must hold the appropriate current annual practising certificate.

The Returning Officer appointed for such election is Eric Lawrence Richardson, Chief Electoral Officer, State Electoral Office, 49 Spring Street, Melbourne.

Nominations, for which forms may be obtained from the Returning Officer, must be lodged with the Returning Officer at the State Electoral Office, 49 Spring Street, Melbourne by 12 noon on Monday, 30 June 1986.

DAVID WHITE
Minister for Health

Audit Act 1958, No. 6203
TREASURY REGULATIONS 1981

*At the Executive Council Chamber, Melbourne, the
sixteenth day of April 1986*

PRESENT:

His Excellency the Governor of Victoria
Mr Walker | Mr Spyker

Whereas paragraph (a) of Regulation 71 (2) of the Treasury Regulations 1981 provides that Regulation 71 shall not apply in respect of the invitation of tenders to expenditure specifically authorized by the Governor in Council on the recommendation of the Treasurer;

And whereas the Treasurer has recommended that the expenditure detailed hereunder be specifically authorized by the Governor in Council;

Now therefore, pursuant to the powers conferred on him by the Treasury Regulations 1981 and all other powers enabling him in that behalf, His Excellency the Governor of the State of Victoria, by and with the advice of the Executive Council thereof, does hereby authorize the expenditure of an amount not exceeding Ten thousand eight hundred dollars (\$10 800) by payment to Ms Anne O'Shea for the provision of consultancy services to provide further survey data and to assist with the preparation of legislation relating to compulsory third party insurance.

And the Honourable Robert Allen Jolly Her Majesty's Treasurer for the State of Victoria, shall give the necessary directions herein accordingly.

L. G. HOUSTON
Clerk of the Executive Council

Audit Act 1958, No. 6203
TREASURY REGULATIONS 1981

*At the Executive Council Chamber, Melbourne, the
sixteenth day of April 1986*

PRESENT:

His Excellency the Governor of Victoria
Mr Walker | Mr Spyker

Whereas paragraph (a) of Regulation 71 (2) of the Treasury Regulations 1981 provides that Regulation 71 shall not apply in respect of the invitation of tenders to expenditure specifically authorized by the Governor in Council on the recommendation of the Treasurer;

And whereas the Treasurer has recommended that the expenditure detailed hereunder be specifically authorized by the Governor in Council;

Now therefore, pursuant to the powers conferred on him by the Treasury Regulations 1981 and all other powers enabling him in that behalf, His Excellency the Governor of the State of Victoria, by

and with the advice of the Executive Council thereof, does hereby authorize the expenditure of an amount not exceeding Twenty thousand dollars (\$20 000) by payment to William Mercer, Campbell, Cook and Knight for the provision of consultancy services to provide actuarial advice in relation to motor vehicle accident compensation.

And the Honourable Robert Allen Jolly, Her Majesty's Treasurer for the State of Victoria, shall give the necessary directions herein accordingly.

L. G. HOUSTON
Clerk of the Executive Council

Audit Act 1958, No. 6203
TREASURY REGULATIONS 1981

At the Executive Council Chamber, Melbourne, the sixteenth day of April 1986

PRESENT:

His Excellency the Governor of Victoria
Mr Walker | Mr Spyker

Whereas paragraph (a) of Regulation 71 (2) of the Treasury Regulations 1981 provides that Regulation 71 shall not apply in respect of the invitation of tenders to expenditure specifically authorized by the Governor in Council on the recommendation of the Treasurer;

And whereas the Treasurer has recommended that the expenditure detailed hereunder be specifically authorized by the Governor in Council;

Now therefore, pursuant to the powers conferred on him by the Treasury Regulations 1981 and all other powers enabling him in that behalf, His Excellency the Governor of the State of Victoria, by and with the advice of the Executive Council thereof, does hereby authorize the expenditure of an amount not exceeding Sixty-four thousand dollars (\$64 000) by payment of Financial Synergy for the provision of consultancy services to continue providing actuarial analyses in relation to compulsory third party insurance.

And the Honourable Robert Allen Jolly, Her Majesty's Treasurer for the State of Victoria, shall give the necessary directions herein accordingly.

L. G. HOUSTON
Clerk of the Executive Council

CITY OF MELBOURNE
By-Law No. 549

Notice is given that, at meetings held on 24 March 1986 and 14 April 1986 the Council made, passed and confirmed a By-Law intitled:

"A By-Law of the City of Melbourne made under section 10 of the *Bourke Street Mall Act 1982* and numbered 549 for regulating, controlling or prohibiting any activity in or in the vicinity of the Bourke Street Mall that is, in the opinion of the

Council, likely to adversely affect the use or enjoyment of the Mall."

The By-Law repeals previous By-Laws for the Bourke Street Mall and provides for regulating controlling or prohibiting any activity in or in the vicinity of the Bourke Street Mall by—

- (a) forbidding the doing of various specified things (clause 4);
- (b) forbidding the doing of various other specified things except with the consent in writing of the Council or an officer authorized by the Council in that behalf (clause 5);
- (c) restricting the entry of vehicles into the Mall except as specified or authorized by the Council (clause 6);
- (d) directing that reasonable orders, directions and requests of corporation officers and employees and members of the police force shall be observed and complied with at all times (clause 7);
- (e) requiring unlawfully erected notices, signs, temporary structures, and the like to be taken down or dismantled by the persons who erected them (clause 8).

A copy of the By-Law is open for inspection free of charge, during the hours of 8.00 a.m. to 4.45 p.m. each day Monday to Friday at the Corporate Services Department, 3rd Floor, Town Hall, Melbourne.

D. N. BETHKE,
2502 Chief Executive Officer and Town Clerk

CITY OF MORDIALLOC
Change of Street Name

Notice is hereby given pursuant to the provisions of section 535 of the *Local Government Act 1958* that the Council of the City of Mordialloc did resolve at a meeting held on Wednesday, 2 April 1986 that part of Bond Street Mordialloc from 60.02 m east of DeHavilland Road westerly to 15.34 m west of Hinkler Road and situated in the estate known as the Moorabbin Airport Industrial Estate be renamed Bond Street West.

D. H. CORBEN,
2503 Town Clerk and City Manager

CITY OF SOUTH MELBOURNE
Road Discontinuance

Notice is hereby given that in accordance with the provisions of section 528 (2) (a) of the *Local Government Act 1958*, the Council of the City of South Melbourne on 7 April 1986 resolved as follows:

- (a) That the portion of the right-of-way numbered 52 and located adjacent to 25 Kerferd Road, South Melbourne, as shown hatched on the plan hereunder is not reasonably required as a road for public use.

- (b) That the said road be discontinued upon publication of this resolution in the *Government Gazette*.
- (c) That the land in the said road shall vest in the City of South Melbourne until sold by private treaty to the abutting owners.
- (d) That notwithstanding such discontinuance the Melbourne and Metropolitan Board of Works shall continue to have and possess the same right, title, power, authority or interest in, or in relation to the whole of the road (whether by virtue of any easement or grant or by force of any Act) with respect to or in connection with any drains or pipes laid or erected in, on or over the road for the purpose of drainage or sewerage or for the supply of water or other like purpose.

Zoned Residential A in the Planning Scheme area.
 Zoned Residential B in the Planning Scheme area.
 Zoned Extractive Industry in the Planning Scheme area.

Crown allotments 21A, 42, 42A, 43, 44A and 44B and part of Crown allotments 45, 46 and 47, Parish of Merrimu and the western portion of Crown allotments B, C and D, section 18, Parish of Merrimu being located in the Lerderderg Park Road, Wells Road and O'Connells Road area.

A copy of the amendment has been deposited at the Shire Office, Shire of Bacchus Marsh, 197 Main Street, Bacchus Marsh and at the Office of the Ministry for Planning and Environment (Plan Inspection Section) Olderfleet Buildings, 477 Collins Street, Melbourne, and will be open for inspection during office hours, by any person, free of charge.

Any persons affected by the amendment are required to set forth in writing any submission they may wish to make with respect to the scheme, addressed to the Shire Secretary, Shire of Bacchus Marsh, P.O. Box 216, Bacchus Marsh by 23 May 1986 and state whether you wish to be heard in respect of your submission.

2505 D. L. MURPHY, Shire Engineer

PLAN OF
 PART OF CROWN ALLOTMENT 38 SECTION 43G
 CITY OF SOUTH MELBOURNE
 PARISH OF MELBOURNE SOUTH
 COUNTY OF BOURKE

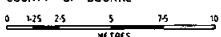
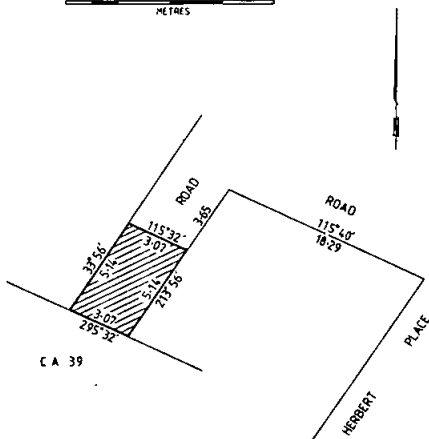
2504 NOEL F. KROPP,
 Chief Executive Officer and Town Clerk

VICTORIA
 ACT 391—FIRST SCHEDULE

I, Alexander Robert Gillespie, head or authorized representative of the denomination known as The Uniting Church in Australia with the consent of The Uniting Church in Australia Property Trust (Victoria) trustees of the land described in the subjoined Statement of Trusts, and of Matthew C. J. Willicombe, of 130 Ballarat Road, Creswick, being the person entitled to minister in or occupy a building or buildings upon the said land, hereby apply to the Governor of the State of Victoria for leave to dispose of the said land by the means and for the purposes mentioned in the said Statement of Trusts, and I hereby certify that the said land was set aside on 15 July 1859, for the purpose of a Wesleyan school.

That the only trustees of the said land resident in the State of Victoria are The Uniting Church in Australia Property Trust (Victoria).

That the only buildings upon the land are—Nil.
 And that the only person entitled to minister in or occupy the same is the above-named Matthew C. J. Willicombe.

Signed by the said Alexander Robert Gillespie.
 We consent to this application—The Uniting Church in Australia Property Trust (Victoria).

The common seal of The Uniting Church in Australia Property Trust (Victoria) was hereunto affixed in pursuance of a

Form 2.1
 Town and Country Planning Act 1961
 SHIRE OF BACCHUS MARSH PLANNING
 SCHEME
 Notice that a Planning Scheme Amendment has been Prepared and is Available for Inspection
 Amendment No. 39
 Notice is hereby given that the Shire of Bacchus Marsh in pursuance of its powers under the *Town and Country Planning Act 1961* has prepared an amendment to the Planning Scheme Ordinance and maps for land being:

Resolution passed at a meeting of the members of the Trust in the presence of—

(SEAL) A. R. GILLESPIE, Member
G. McANALLY, Member

Signed by the said Matthew C. J. Willicombe, Minister.

Statement of Trusts

Description of Land—Wesleyan school site set apart for Wesleyan school purposes. 2023 square metres, Parish of Dowling Forest, County of Grenville being Crown Allotment No.

Commencing at the south-eastern angle of Crown allotment 10, section 2; bounded thence by that allotment bearing 0°00' 43.15 metres; by Crown allotment B bearing 90°00' 40.23 metres and 180°00' 57.43 and thence by the Western Highway bearing 289°30' 42.65 metres to the point of commencement.

Names of Trustees—The Uniting Church in Australia Property Trust (Victoria).

Powers of Disposition—Such powers of disposition including powers of sale, lease or mortgage as are given to the Uniting Church in Australia Property Trust (Victoria) Act, No. 9021 of 1977.

Purposes to which Proceeds of Disposition are to be Applied—To such Uniting Church in Australia purposes as shall be approved by the Committee of the Victorian Synod of the Uniting Church in Australia.

2518

Publications Availability

Publications may be purchased from the
Victorian Government Bookshop
41 St Andrews Place East Melbourne
(PO Box 203 North Melbourne 3051)
Telephone Inquiries (03) 320 0299

Mail Orders and Postage

A postage and packaging fee must be added to the cost of the requested publication using the table of rates below. Remittances should be made payable to the 'Victorian Government Printing Office'.

Bankcard

Purchases may be made using Bankcard facilities in the Bookshop and by mail order. Bankcard mail orders require the Bankcard number, expiry date, name, address and signature of customer to be supplied. (Minimum purchase of \$5.00 applies).

<i>Total Price of Publications</i>	<i>Postage Packaging Fee</i>
\$ 0.00 to \$ 2.00	\$ 0.80
\$ 2.05 to \$ 5.00	\$ 1.10
\$ 5.05 to \$ 25.00	\$ 2.50
\$ 25.05 to \$ 75.00	\$ 3.00
\$ 75.05 to \$125.00	\$ 3.50
\$125.05 to \$200.00	\$ 4.00
\$200.05 and over	at cost

Publication Details

The *Victoria Government Gazette* is published every Wednesday, unless otherwise advertised.

Copy Deadline

Private advertisements will be accepted by:

Gazette Advertising

Victorian Government Printing Office
PO Box 203 North Melbourne 3051, no later than 1 p.m. on the day before publication.

Advertising Rates

Single column × cm/part	..	\$3.60
Double column × cm/part	..	\$7.20
Full page	..	\$151.00

Ordinary rates will apply to material submitted for publication before 1 p.m. Tuesday. Double rates will apply for material submitted between 1 p.m. and 3.30 p.m. Tuesday.

Advertisers should note:

- There are approximately 30 words to each column centimetre depth;
- Signatures (in particular) and proper names must be written clearly in the text;
- Advertising material should be double-spaced and confined to ONE SIDE ONLY of each sheet of paper
- Documents NOT CLEARLY PREPARED will be returned to the sender, unpublished.

Correspondence

All correspondence should be addressed to:

Gazette Advertising

Victorian Government Printing Office
PO Box 203 North Melbourne 3051
Telephone Inquiries (03) 320 0100

General Information

The following guidelines should be followed for the publication of official material in the *Victoria Government Gazette*.

Publication of official material

- Duplicate copies should be submitted for the use of the Gazette Officer.
- Material submitted to the Executive Council for Gazettal will normally be published in the next week's issue.
- Where urgent gazettal is required, special arrangements should be made with the:
 - Gazette Officer
 - Department of the Premier and Cabinet
 - Government Branch
 - 2nd Floor, 1 Treasury Place
 - Melbourne 3000
 - Telephone Inquiries (03) 651 5153

Publication of other material

- All other material authorized by a responsible officer should be forwarded to the Gazette Officer no later than 9.30 a.m. on Tuesday.
- Lengthy or complicated notices should be forwarded several days before publication.
- Proofs will be supplied only when requested or at the direction of the Gazette Officer. They should be returned quickly to avoid delay in publication.
- No additions or amendments to material for publication will be accepted by telephone.

Late Copy

Copy received after 3.30 p.m. on the day prior to publication at the Victorian Government Printing Office will be placed in the following issue of the *Victoria Government Gazette*, irrespective of any date/s mentioned in the copy.

Agents

The following have been appointed agents to receive advertisements for the *Victoria Government Gazette*:

- Armstrong's Communications Pty Ltd
191 Queen Street Melbourne 3000
- Blane's Authorized Newsagents 162
Murray Street Colac 3250
- Cornell R G 126 Eighth Street Mildura
3500
- Franks H and Co 184 Ryrie Street Geelong
3220
- Gordon and Gotch Australasia Ltd
25-37 Huntingdale Road Burwood 3125
- Harston, Partridge & Co. Pty Ltd 455
Little Collins Street Melbourne 3000
- Kyneton Guardian Pty Ltd PO Box 18
Kyneton 3444
- The Mercantile Exchange 108 Queen
Street Melbourne 3000
- Bridgemall Newsagency 63 Bridgemall
Road Ballarat 3350
- McGill's Authorized Newsagency
183-185 Elizabeth Street Melbourne 3000
- McNaughton P R and L A 112-114
Gray Street Hamilton 3300
- Powney's Authorized Newsagency 293
Hargreaves Street Bendigo 3550
- Purdie J & Co. 138 Moorabool Street
Geelong 3220
- Vernons of Richmond 261 Bridge Road
Richmond 3121

C O N T E N T S

	Page
Acts of Parliament	1019
Appointments	1041
Cemeteries—Scale of Fees	1036
Contracts	1019
Contracts Accepted—Amendments	1091
Courts	1029
Estates of Deceased Persons	1039
Government Notices	1019
Late Notices	1091
Notice of Making of Statutory Rules	1090
Orders in Council—	
Acts—Hospitals and Charities; Land; Crown Land (Reserves); Audit; Motor Car; West Moorabool Water Board; Water and Sewerage Authorities (Restructuring); Latrobe Valley; Melbourne Cricket Ground; Stamps; National Parks; Credit; Hospitals and Charities; Crown Land (Reserves)	1043 et seq
Police Sale	1029
Private Advertisements	1053
Proclamations	1019
Regulations—	
Acts—Police	1025
Resignation	1042
Tenders	1053