

[207]

PUBLISHED BY AUTHORITY



# Victoria Government Gazette

No. 5—Wednesday, 29 January 1986

---

---

## CHANGE OF LOCATION GAZETTE OFFICE

Department of the Premier and Cabinet

As from 3 February 1986 the Gazette Office will be located in the Government Branch, 2nd Floor, 1 Treasury Place, Melbourne.

As from that date all articles for publication in the Gazette should be addressed to: Mr G. Gaspars, Gazette Officer, Department of the Premier and Cabinet, Government Branch, 2nd Floor, 1 Treasury Place, Melbourne. 3002.

Please also note the change of telephone number.

The old number 651 1164 will no longer be operative after 3 February 1986. The new telephone number will be 651 5153.

**G. GASPARS**  
Gazette Officer

Department of the Premier  
and Cabinet, 20 January 1986

**PROCLAMATIONS**

*Land Act 1958*  
**ROAD PROCLAIMED**

**PROCLAMATION**

By His Excellency the Lieutenant-Governor of the State of Victoria and its Dependencies in the Commonwealth of Australia, &c., &c., &c.

I, the Lieutenant-Governor of the State of Victoria, in the Commonwealth of Australia, by and with the advice of the Executive Council of the said State, pursuant to the provisions of section 25 (3) (c) of the *Land Act 1958*, do hereby proclaim as road the Crown land hereinafter described, viz:

Township of Ballarat East, municipal district of City of Ballarat being the land indicated by hatching on plan hereunder—L3 3500 B128 (51).

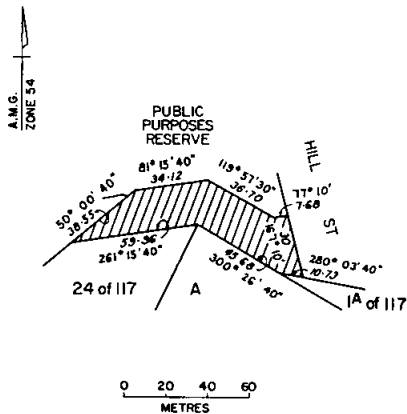

Given under my Hand and the Seal of the State of Victoria aforesaid, at Melbourne, this twenty-first day of January in the year of our Lord One thousand nine hundred and eighty-six and in the thirty-fourth year of the reign of Her Majesty Elizabeth the Second, Queen of Australia.

(L.S.) J. Mcl. YOUNG

By His Excellency's Command

PETER SPYKER  
Acting Minister for Conservation, Forests and Lands

GOD SAVE THE QUEEN!

*Land Act 1958*  
**ROAD PROCLAIMED**

**PROCLAMATION**

By His Excellency the Lieutenant-Governor of the State of Victoria and its Dependencies in the Commonwealth of Australia, &c., &c., &c.

I, the Lieutenant-Governor of the State of Victoria, in the Commonwealth of Australia, by and with the advice of the Executive Council of the said State, pursuant to the provisions of section 25 (3) (c) of the *Land Act 1958*, do hereby proclaim as road the Crown land hereinafter described, viz:

Township of Maffra in the Shire of Maffra being the land indicated by hatching on plan hereunder—Rs.10393 M89 (4).

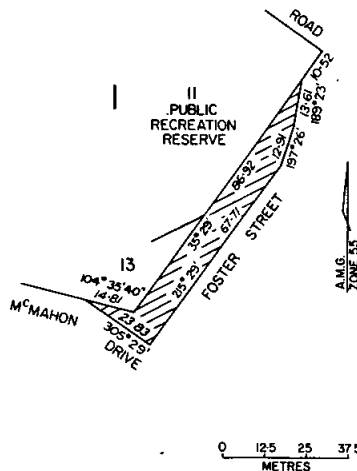

Given under my Hand and the Seal of the State of Victoria aforesaid, at Melbourne, this twenty-first day of January in the year of our Lord One thousand nine hundred and eighty-six and in the thirty-fourth year of the reign of Her Majesty Elizabeth the Second, Queen of Australia.

(L.S.) J. Mcl. YOUNG

By His Excellency's Command

PETER SPYKER  
Acting Minister for Conservation, Forests and Lands

GOD SAVE THE QUEEN!

*Land Act 1958*  
**ROAD PROCLAIMED**

**PROCLAMATION**

By His Excellency the Lieutenant-Governor of the State of Victoria and its Dependencies in the Commonwealth of Australia, &c., &c., &c.

I, the Lieutenant-Governor of the State of Victoria, in the Commonwealth of Australia, by and with the advice of the Executive Council of the said State, pursuant to the provisions of section 25 (3) (c) of the *Land Act 1958*, do hereby proclaim as road the Crown land hereinafter described, viz:

Township of Shepparton in the Municipal district of the City of Shepparton being the land indicated by hatching on plan hereunder—Rs.7187 S283 (H3).

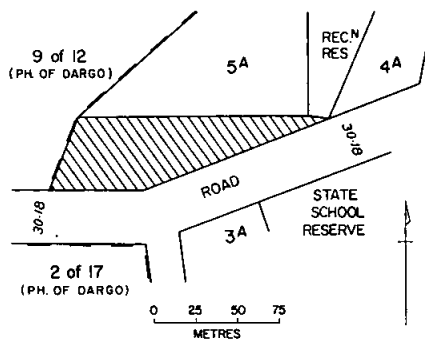

Given under my Hand and the Seal of the State of Victoria aforesaid, at Melbourne, this twenty-first day of January in the year of our Lord One thousand nine hundred and eighty-six and in the thirty-fourth year of the reign of Her Majesty Elizabeth the Second, Queen of Australia.

(L.S.) J. McI. YOUNG

By His Excellency's Command  
PETER SPYKER  
Acting Minister for Conservation, Forests and Lands

GOD SAVE THE QUEEN!

*Land Act 1958*  
**ROAD PROCLAIMED**

**PROCLAMATION**

By His Excellency the Lieutenant-Governor of the State of Victoria and its Dependencies in the Commonwealth of Australia, &c., &c., &c.

I, the Lieutenant-Governor of the State of Victoria, in the Commonwealth of Australia, by and with the advice of the Executive Council of the said State, pursuant to the provisions of section 25 (3) (c) of the *Land Act 1958*, do hereby proclaim as road the Crown land hereinafter described, viz:

Municipal District of the City of Maryborough Parish of Maryborough being the road indicated by hatching on plan hereunder—(M66 (19) (L3-3636).

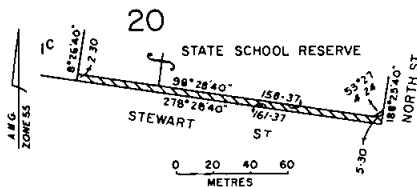
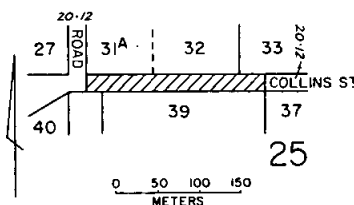

Given under my Hand and the Seal of the State of Victoria aforesaid, at Melbourne, this twenty-first day of January in the year of our Lord One thousand nine hundred and eighty-six and in the thirty-fourth year of the reign of Her Majesty Elizabeth the Second, Queen of Australia.

(L.S.) J. McI. YOUNG

By His Excellency's Command  
PETER SPYKER  
Acting Minister for Conservation, Forests and Lands

GOD SAVE THE QUEEN!

*Land Act 1958*  
**ROAD PROCLAIMED**

**PROCLAMATION**

By His Excellency the Lieutenant-Governor of the State of Victoria and its Dependencies in the Commonwealth of Australia, &c., &c., &c.

I, the Lieutenant-Governor of the State of Victoria, in the Commonwealth of Australia, by and with the advice of the Executive Council of the said State, pursuant to the provisions of section 25 (3) (c) of the *Land Act 1958*, do hereby proclaim as road the Crown land hereinafter described, viz:

Township of Dargo in the municipal district of the Shire of Avon, being the land indicated by hatching on plan hereunder—(L10-3504) (D163 (5)).

Given under my Hand and the Seal of the State of Victoria aforesaid, at Melbourne, this twenty-first day of January in the year of our Lord One thousand nine hundred and eighty-six and in the thirty-fourth year of the reign of Her Majesty Elizabeth the Second, Queen of Australia.

(L.S.) J. Mcl. YOUNG  
By His Excellency's Command

PETER SPYKER  
Acting Minister for Conservation,  
Forests and Lands

GOD SAVE THE QUEEN!

*Land Act 1958*

**ROAD PROCLAIMED**

**PROCLAMATION**

By His Excellency the Lieutenant-Governor of the State of Victoria and its Dependencies in the Commonwealth of Australia, &c., &c., &c.

I, the Lieutenant-Governor of the State of Victoria, in the Commonwealth of Australia, by and with the advice of the Executive Council of the said State, pursuant to the provisions of section 25 (3) (c) of the *Land Act 1958*, do hereby proclaim as road the Crown land hereinafter described, viz.:

Parish of Corio, municipal district of the City of Corio and being the land indicated by hatching on plan hereunder—(Rs. 5506) (Parish 2454).

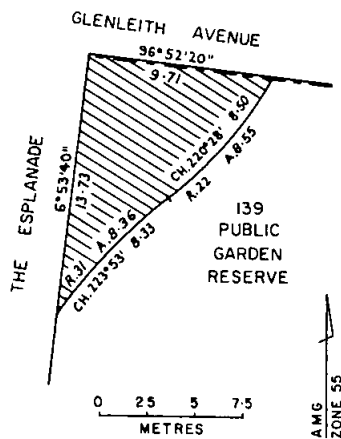

Given under my Hand and the Seal of the State of Victoria aforesaid, at Melbourne, this twenty-first day of January in the year of

our Lord One thousand nine hundred and eighty-six and in the thirty-fourth year of the reign of Her Majesty Elizabeth the Second, Queen of Australia.

(L.S.) J. Mcl. YOUNG  
By His Excellency's Command

PETER SPYKER  
Acting Minister for Conservation,  
Forests and Lands

GOD SAVE THE QUEEN!

*Land Act 1958*

**ROAD PROCLAIMED**

**PROCLAMATION**

By His Excellency the Lieutenant-Governor of the State of Victoria and its Dependencies in the Commonwealth of Australia, &c., &c., &c.

I, the Lieutenant-Governor of the State of Victoria, in the Commonwealth of Australia, by and with the advice of the Executive Council of the said State, pursuant to the provisions of section 25 (3) (c) of the *Land Act 1958*, do hereby proclaim as road the Crown land hereinafter described, viz.:

Township of Smiths Gully Parish of Queenstown being the land indicated by hatching on plan hereunder—(S475 (1) (L12-0011)).

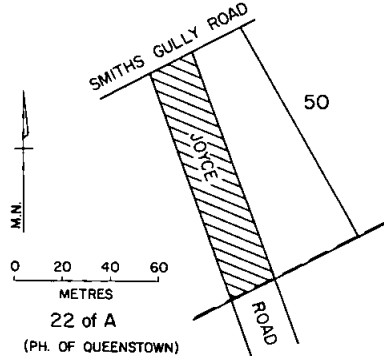

Given under my Hand and the Seal of the State of Victoria aforesaid, at Melbourne, this twenty-first day of January in the year of our Lord One thousand nine hundred and eighty-six and in the thirty-fourth year of the reign of Her Majesty Elizabeth the Second, Queen of Australia.

(L.S.) J. Mcl. YOUNG  
By His Excellency's Command

PETER SPYKER  
Acting Minister for Conservation, Forests and  
Lands

GOD SAVE THE QUEEN!

*Land Act 1958*  
**ROAD PROCLAIMED**

**PROCLAMATION**

By His Excellency the Lieutenant-Governor of the State of Victoria and its Dependencies in the Commonwealth of Australia, &c., &c., &c.

I, the Lieutenant-Governor of the State of Victoria, in the Commonwealth of Australia, by and with the advice of the Executive Council of the said State, pursuant to the provisions of section 25 (3) (c) of the *Land Act 1958*, do hereby proclaim as road the Crown land hereinafter described, viz.:

Parish of Tyntynder North in the Municipality of the Shire of Swan Hill being the land indicated by hatching on plan hereunder—(L5 566) (T244 (13)).

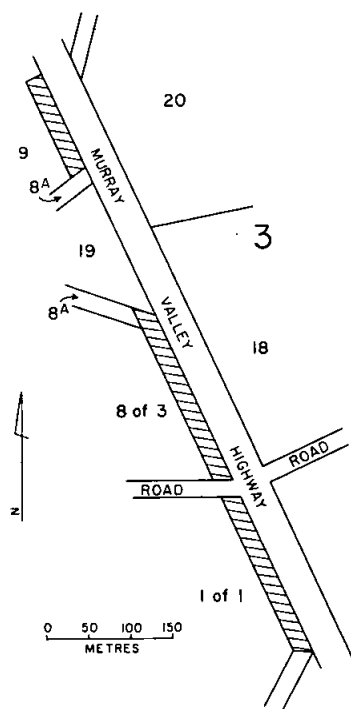

Given under my Hand and the Seal of the State of Victoria aforesaid, at Melbourne, this twenty-first day of January in the year of our Lord One thousand nine hundred and

eighty-six and in the thirty-fourth year of the reign of Her Majesty Elizabeth the Second, Queen of Australia.

(L.S.) J. Mcl. YOUNG

By His Excellency's Command

PETER SPYKER  
Acting Minister for Conservation,  
Forests and Lands

GOD SAVE THE QUEEN!

**GOVERNMENT NOTICES**

**STATE TENDER BOARD  
CONTRACTS ACCEPTED  
AMENDMENTS**

<i>Schedule Number</i>	<i>Item Number</i>	<i>New Rate</i>	<i>Effective Date</i>
<b>\$</b>			
<i>Batteries (Lead Acid Cells)</i>			
1/02	1	Exide	3.2.86
	2	Price List	1.1.86
<i>Discounts remain unchanged</i>			
<i>Chemicals, Agricultural, etc.</i>			
1/03	19	4.35	20.1.86
<i>Hand Tools (General)</i>			
1/56	77	7.79	18.12.85
	93	4.83	
	94	3.79	
	95	4.11	
	96	4.34	
	118	6.47	
	136	4.27	
	306	10.53	
	307	13.04	
	308	15.64	
<i>Light Commercial Motor Vehicles</i>			
1/59A (3)	B	7609.59	27.1.86
	D	8688.44	
1/59A (4)	D	8152.60	27.1.86
1/59B (4)	D	10058.95	27.1.86
1/59C (1)	C	9866.77	27.1.86
1/59C (2)	B	8718.27	
	C	9550.83	
<i>Provisions—Melbourne and Metropolitan District</i>			
2/01	60	1.74	9.12.85
	61	1.66	
	62	1.47	

J. M. PAWSON  
Secretary to the Tender Board

*Private Agents Act 1966*

## NOTICE OF RECEIPT OF APPLICATIONS FOR LICENCES UNDER THE PROVISIONS OF THE PRIVATE AGENTS ACT 1966

The Clerk(s) of the Magistrates' Court(s) as listed hereunder hereby give notice that applications, as under, have been lodged for hearing by the said Court(s) on the date(s) specified.

Any person desiring to object to any of such applications must—

- (a) lodge with the respective Clerk of the Magistrates' Court a notice in the prescribed form of his objection and of the grounds thereof;
- (b) cause a copy of such notice to be served personally or by post upon the applicant at least three days before the hearing of the application; and
- (c) send or deliver—
  - (i) where the objection is not made by the officer in charge of the police district in which the Court is situated—a copy of the notice to such officer; and
  - (ii) where the objection is not made by the Registrar or Deputy Registrar—a copy to the Registrar.

<i>Full Name of Applicant*</i>	<i>Place of Abode of Applicant or Nominee</i>	<i>Name of Firm or Corporation</i>	<i>Address for Registration</i>	<i>Type of Licence</i>	<i>Date of Hearing</i>
<b>MAGISTRATES' COURT, CAMBERWELL</b>					
Stevens, Andrew James	36 Royal St, Upwey	J.R.N. Investments Pty. Ltd.	1214 Toorak Rd, Hartwell	Watchman	19.2.86
Dated at Camberwell 21 January 1986 P. M. PATTISON, Clerk of the Magistrates' Court					
<b>MAGISTRATES' COURT, BOX HILL</b>					
Theofanides, Constantine	19 Jeffrey St, Blackburn			Watchman	11.2.86
Reynen, Laurence John	32 Linden St, Blackburn			Guard Agent	13.2.86
Dated at Box Hill 15 January 1986 P. O. FARRELL, Clerk of the Magistrates' Court					
<b>MAGISTRATES' COURT, GEELONG</b>					
Cakebread, Phillip Ian	Box 5 Drysdales Rd, Little River	Armaguard 50 Autumn St, Geelong West	50 Autumn St, Geelong West	Watchman	6.2.86
Dated at Geelong 13 January 1986 A. DUNLOP, Clerk of the Magistrates' Court					
<b>MAGISTRATES' COURT, RINGWOOD</b>					
Edwards, Mark Keith	31 Birds Rd, Ferny Creek	Mayne Nickless Ltd.	14A Thornton Cres, Mitcham	Watchman	17.2.86
Cameron, Peter John	31 Invermay Gve, Rosanna		737 Boronia Rd, Wantirna	Inquiry Agent	"
Dated at Ringwood 15 January 1986 M. TIPPETT, Clerk of the Magistrates' Court					
<b>MAGISTRATES' COURT, OAKLEIGH</b>					
Kokonis, Anthony	1/106 Mimosa Rd, Carnegie		96 Murrumbeena Rd, Murrumbeena	Watchman	21.2.86
Dated at Oakleigh 17 January 1986 T. KEARNEY, Clerk of the Magistrates' Court					

\*Or in the case of a firm or corporation, of the Nominee

## PRIVATE AGENTS—continued

Full Name of Applicant*	Place of Abode of Applicant or Nominee	Name of Firm or Corporation	Address for Registration	Type of Licence	Date of Hearing
MAGISTRATES' COURT, BOX HILL					
Nolan, Patrick Vincent	5/772 Whitehorse Rd, Surrey Hills	Metro Investigations	5/772 Whitehorse Rd, Surrey Hills	Inquiry Agent	24.2.86
" "	"	"	"	Process Server	"

Dated at Box Hill 22 January 1986  
S. R. McMILLAN, Clerk of the Magistrates' Court

MAGISTRATES' COURT, MOONEE PONDS					
McRn, Sahan	71/12 Holland Crt, Flemington	Ralph Edwards (T/A High Rise Security Services)	2/58 Holland Crt, Flemington	Watchman	18.2.86

Dated at Moonee Ponds 17 January 1986  
R. NIEMER, Clerk of the Magistrates' Court

\*Or in the case of a firm or corporation, of the Nominee

## CONTRACTS ACCEPTED—(Series 1986)

Schedule No. 1/72

## CARBON PAPERS AND TYPEWRITER RIBBONS

Contract from 1 January 1986 to 31 December 1986

- 1985/700 Adler Business Machines, 35 Albert Road, Melbourne. Telephone 267 5311.  
1985/701 Carmassey Carbons & Ribbons Mfg. Pty. Ltd., 593 Gardeners Road, Mascot, N.S.W. Telephone (02) 667 2431.  
1985/702 Columbia Products Ltd., 706 Mowbray Road, Lane Cove, N.S.W. Telephone (02) 427 0311.  
1985/704 Graphic Ribbon Co. Pty. Ltd., 20 Kylie Place, Moorabbin. Telephone 555 3800.  
1985/707 Olivetti Australia Pty. Ltd., 568 St Kilda Road, Melbourne. Telephone 529 7299.  
1985/711 Zodiac Office Products Pty. Ltd., 20 Amberley Crescent, Dandenong. Telephone 792 5779.

All supplies under this Schedule will be ordered by the Stores Officer, Education Department and must be delivered as directed by him.

Item No.	Description of Articles	Unit of Measure	Rate	Name of Contractor
§				
SUB-SCHEDULE A				
CARBON PAPERS				
For Typewriters, in packets of 100 sheets only, as ordered to take up to—				
1.	5 copies, standard weight, A4 size, black	per pkt	2.30	Carmassey Carbon & Ribbon Manufacturing Pty. Limited
2.	12 copies, light weight A4 size, black	per pkt	2.30	
3.	5 copies, plastic filmback, black, medium weight	per pkt	6.40	
4.	Pen/Pencil—in packets of 100 sheets, A4, blue	per pkt	1.90	

Item No.	Description of Articles	Unit of Measure	Rate	Name of Contractor
\$				
<b>SUB-SCHEDULE B</b>				
<b>TYPEWRITER RIBBONS</b>				
Standard Nylon Fabric Ribbon—				
5.	Black, 13mm wide and approx. 10m long;	per each	0.85	Columbia Products Ltd.
6.	Fabric—to fit both manual and electric Red and black, 13mm wide and approx. 10m long; Fabric—to fit both manual and electric	per each	0.85	
7.	Black, Fabric, cartridge to suit Adler Gabriele 9009	per each	6.81	Adler Business Machines Pty. Ltd.
<b>FILM CARBON RIBBONS</b>				
8.	Black, film carbon, 8mm wide × 210mm long, 89mm diam. to suit standard electric machines except IBM type	per each	0.50	Carmassey Carbon and Manufacturing Pty. Limited
9.	Black, correctable, carbon film cartridge to suit Golf Ball machines, orange hub (to be compatible with Brother EM-1, IBM Selectric 82 and Remington SE 100) Group 140C, 155mm long	per each	1.20	
10.	Black, correctable carbon film cartridge, to suit Golf Ball machines, yellow hub (to be compatible with Adler SE 1000 and Olympia SGE 75C machines) Group 140 CS, 125mm long	per each	1.17	Zodiac Office Products Pty. Ltd.
11.	Black, correctable carbon film cartridge, to suit Adler SE Series electronic Daisy Wheel machine. Group 185C	per each	2.65	Graphic Ribbon Co. Pty. Ltd.
12.	Black, correctable carbon film cartridge to suit Adler Gabriele 9009 electronic Daisy Wheel machines	per each	3.60	Adler Business Machines Pty. Ltd.
13.	Black, correctable carbon film cartridge to suit Olivetti ET 110 and ET 115 electronic Daisy Wheel machines. Group 165C	per each	5.20	Olivetti Australia Pty. Ltd.
14.	Black, correctable carbon film cartridge to suit Brother CE and EM series electronic Daisy Wheel machines, Group 154C	per each	..	Apply Tender Board
15.	Black, correctable carbon film cartridge to suit IBM 6705 Golf Ball machines	per each	..	Purchase (Regulation 84)
16.	<b>CORRECTION TAPES</b> Clear to suit Adler Daisy Wheel. Group 143	per each	0.30	Graphic Ribbon Co. Pty. Ltd.
17.	Clear—to suit Golf Ball machines	per each	0.30	
18.	White—to suit IBM Golf Ball machines. Group 141	per each	0.30	
19.	Clear—to suit Olivetti ET 110 and 115 Daisy Wheel machines. Group 149	per each	0.50	
20.	White—to suit Adler Gabriele 9009 Daisy Wheel machine	per each	0.30	

Approved—R. C. Fordham, Acting Treasurer—7.1.86

## Police Regulation Act, Section 122

**SALE OF UNCLAIMED MOTOR VEHICLE**

An owner is required for an unregistered white Holden one tone vehicle.

The vehicle came into the possession of Police on 24/1/85 and if not claimed, will be sold by public auction at the Echuca Police Station, 11 Dickinson Street, Echuca, on Wednesday, 26/2/86 at 10.00 a.m.

S. I. MILLER  
Chief Commissioner

## Police Regulation Act, Section 122

**SALE OF UNCLAIMED PROPERTY**

An owner is required for a yellow, home made 11 foot dingy and a red steel home made boat trailer.

The property came into the possession of Police on 2 September 1985, and if not claimed will be sold by public auction at the Dandenong Police Station, 50 Langhorne Street, Dandenong, on Friday, 7 March 1986 at 2.00 p.m.

S. I. MILLER  
Chief Commissioner



*Town and Country Planning Act 1961*  
**SHIRE OF LILLYDALE PLANNING SCHEME**  
 Amendment No. 211  
 Notice of Amendment

In pursuance of the powers conferred by the *Town and Country Planning Act 1961*, the Lieutenant-Governor in Council on 21 January 1986, amended the abovementioned scheme in respect of the municipal district of the Shire of Lillydale and for which the Lillydale Shire Council is the Responsible Authority.

The amendment comes into operation on the date this Notice is published in the *Government Gazette*.

The amendment includes the transfer of a 3.05 metre strip of land from Lot 2, LP 138154, Summerlea Road, Mt. Dandenong to Lot 1, LP 38841 to formalize the existing access to two allotments currently being used for nursery gardening.

A copy of the documents may be inspected free of charge, during office hours, at the office of the Ministry for Planning and Environment, The Olderfleet Buildings, 477 Collins Street, Melbourne, and at the office of the Shire of Lillydale, Shire Offices, Lilydale.

**JOHN LAWSON**  
 Deputy Secretary for Planning and Environment

*Town and Country Planning Act 1961*  
**SHIRE OF BACCHUS MARSH PLANNING SCHEME**  
 Amendment No. 33  
 Notice of Approval

In pursuance of the powers conferred by the *Town and Country Planning Act 1961*, the Lieutenant-Governor in Council on 21 January 1986, approved the abovementioned scheme in respect of the municipal district of the Shire of Bacchus Marsh and for which the Shire of Bacchus Marsh is the Responsible Authority.

The scheme comes into operation on the date this Notice is published in the *Government Gazette*.

The scheme includes a variation to the Planning Scheme Ordinance which is an interim measure to give Council control over the treatment of trees in the Avenue of Honour until a comprehensive amendment for the Shire is completed.

A copy of the documents may be inspected free of charge, during office hours, at the office of the Ministry for Planning and Environment, The Olderfleet Buildings, 477 Collins Street, Melbourne, and at the office of the Shire of Bacchus Marsh, Council Chambers, Bacchus Marsh.

**JOHN LAWSON**  
 Deputy Secretary for Planning and Environment

*Town and Country Planning Act 1961*  
**SHIRE OF ALBERTON (COASTAL) PLANNING SCHEME**  
 Amendment No. 26  
 Notice of Approval

In pursuance of the powers conferred by the *Town and Country Planning Act 1961*, the Lieutenant-Governor in Council on 21 January 1986, approved the abovementioned scheme in respect of the municipal district of the Shire of Alberton, and for which the Shire of Alberton is the Responsible Authority.

The scheme comes into operation on the date this Notice is published in the *Government Gazette*.

The scheme varies Clause 34 (h) by deleting the word—"not less than 0.5 hectares in area and . . ."

A copy of the documents may be inspected free of charge, during office hours, at the office of the Ministry for Planning and Environment, The Olderfleet Buildings, 477 Collins Street, Melbourne, and at the office of the Responsible Authority, the Shire of Alberton, Shire Offices, Commercial Road, Yarrum.

**DAVID YENCKEN**  
 Secretary for Planning and Environment

*Town and Country Planning Act 1961*  
**SHIRE OF BASS PLANNING SCHEME**  
 Amendment No. 16  
 Notice of Approval

In pursuance of the powers conferred by the *Town and Country Planning Act 1961*, the Lieutenant-Governor in Council on 21 January 1986, approved the abovementioned scheme in respect of the municipal district of the Shire of Bass and for which the Council of the Shire of Bass is the Responsible Authority.

The scheme comes into operation on the date this Notice is published in the *Government Gazette*.

The scheme includes a change in reservation of land at the north west corner of Bass Highway and Pier Road Grantville from Public Purposes—Education to part Public Purposes—Municipal Purposes Reserve and part Residential Zone.

A copy of the documents may be inspected free of charge, during office hours, at the office of the Ministry for Planning and Environment (Plan Inspection Section), The Olderfleet Buildings, 477 Collins Street, Melbourne, and at the office of the Responsible Authority, the Council of the Shire of Bass, Main Road, Archies Creek.

**DAVID YENCKEN**  
 Secretary for Planning and Environment

*Town and Country Planning Act 1961*  
**GISBORNE SHIRE PLANNING SCHEME**  
 Amendment No. 11  
 Notice of Approval

In pursuance of the powers conferred by the *Town and Country Planning Act 1961*, the Lieutenant-Governor in Council on 21 January 1986, approved the abovementioned scheme in respect of the municipal district of the Shire of Gisborne and for which the Gisborne Shire is the Responsible Authority.

The scheme comes into operation on the date this Notice is published in the *Government Gazette*.

The scheme includes an Ordinance amendment to allow a detached house on each of Lots 18 and 19 Alton Road, a detached house on combined Lots 35 and 36 Governors Road and a detached house (existing) on Lot 37 Mabel Crescent, Gisborne.

A copy of the documents may be inspected free of charge, during office hours, at the office of the Ministry for Planning and Environment, The Olderfleet Buildings, 477 Collins Street, Melbourne, and at the office of the Council of the Shire of Gisborne at Gisborne.

JOHN LAWSON  
 Deputy Secretary for Planning and Environment

*Town and Country Planning Act 1961*  
**SHIRE OF SHERBROOKE PLANNING**  
**SCHEME 1969 (URBAN AREAS)**  
 Amendment No. 32  
 Notice of Approval

In pursuance of the powers conferred by the *Town and Country Planning Act 1961*, the Lieutenant-Governor in Council on 21 January 1986, approved the abovementioned scheme in respect of the municipal district of the Shire of Sherbrooke, and for which the Sherbrooke Shire Council is the Responsible Authority.

The scheme comes into operation on the date this Notice is published in the *Government Gazette*.

The scheme includes rezoning Lot 167, LP 6970, The Crescent, Belgrave Heights, from Local Commercial Zone to General Residential Zone and an amendment to the Restructure Plan of the Planning Scheme Ordinance.

A copy of the documents may be inspected free of charge, during office hours, at the office of the Ministry for Planning and Environment, The Olderfleet Buildings, 477 Collins Street, Melbourne, and at the office of the Council of the Shire of Sherbrooke, Glenfern Road, Upwey.

JOHN LAWSON  
 Deputy Secretary for Planning and Environment

*Town and Country Planning Act 1961*  
**MELBOURNE METROPOLITAN PLANNING**  
**SCHEME**

Revocation No. 44

Notice of Revocation

Notice of Order Under Section 32 (5)

In pursuance of the powers conferred by the *Town and Country Planning Act 1961*, the Lieutenant-Governor in Council on 21 January 1986, revoked in part the abovementioned scheme in respect of Lot 106, LP 6285, Bainbridge Avenue, Frankston, and made an Order pursuant to section 32 (5):

The Order provides that the land so revoked may be used and developed—

- (a) as if it were land to which the Melbourne Metropolitan Planning Scheme applies;
- (b) as if it were in a Residential C Zone;
- (c) for the purposes of a commercial vehicle park, notwithstanding the provisions of section 6 to the Table to Clause 7 of the Scheme, in association with the industry on adjoining land generally to the east subject to the grant of a permit and to any conditions which may be included therein by the Council of the City of Frankston.

A copy of the Order relating to the revocation may be inspected during office hours at the office of the Ministry for Planning and Environment, The Olderfleet Buildings, 477 Collins Street, Melbourne.

JOHN LAWSON  
 Deputy Secretary for Planning and Environment

*Town and Country Planning Act 1961*  
**MELBOURNE METROPOLITAN PLANNING**  
**SCHEME**

Notice of Execution of Instrument of Variation of  
 Delegation

Notice is hereby given that the Minister for Planning and Environment in respect to the Melbourne Metropolitan Planning Scheme has executed an instrument of variation of delegation dated 22 January 1986 varying the delegation to the City of Camberwell of powers, authorities and responsibilities in respect of the said Scheme delegated by instrument of delegation executed on 3 February 1986.

The variation of delegation shall have force and effect from the date of publication of this notice.

Copies of the instrument of variation of delegation may be inspected during office hours at the office of the Ministry for Planning and Environment and the office of the City of Camberwell at Camberwell.

DAVID YENCKEN  
 Secretary for Planning and Environment

*Town and Country Planning Act 1961*  
MELBOURNE METROPOLITAN PLANNING  
SCHEME

Amendment No. 393  
Notice of Amendment

In pursuance of the powers conferred by the *Town and Country Planning Act 1961*, the Lieutenant-Governor in Council on 21 January 1986, amended the abovementioned scheme in respect of the municipal district of the Shire of Werribee and for which the Minister for Planning and Environment, and the Shire of Werribee are the Responsible Authorities.

The amendment comes into operation on the date this notice is published in the *Government Gazette*.

The amendment includes the reservation of land required for the construction of the Duncans Road/Princes Freeway interchange.

A copy of the documents may be inspected free of charge, during office hours, at the office of the Ministry for Planning and Environment, The Oldfleet Buildings, 477 Collins Street, Melbourne.

JOHN LAWSON  
Deputy Secretary for Planning and Environment

*Town and Country Planning Act 1961*  
NOTICE THAT A PLANNING SCHEME HAS  
BEEN PREPARED AND IS AVAILABLE FOR  
INSPECTION

Melbourne Metropolitan Planning Scheme  
Amending Scheme No. 392

Notice is hereby given that the Minister for Planning and Environment in pursuance of the powers under the *Town and Country Planning Act 1961*, has prepared a Planning Scheme which proposes to introduce a new Office 'B' Zone and to rezone land on the north-east corner of Springvale Road and Ferntree Gully Road, City of Waverley, to Office 'B' Zone.

A copy of the Amending Scheme has been deposited at the offices of the Ministry for Planning and Environment, The Oldfleet Buildings, 477 Collins Street, Melbourne and Lucknow Street, Mitcham, and the municipal offices of the City of Waverley, Springvale Road, Glen Waverley, and will be open for inspection during office hours by any person, free of charge.

Any persons affected by the Amending Scheme are required to set forth in writing, any submissions they may wish to make with respect to the Amending Scheme, addressed to the Secretary for Planning and Environment, Box 2240r, Melbourne, 3001, by 3 March 1986 and to state whether they wish to be heard in respect of their submissions.

Dated 28 January 1986

DAVID YENCKEN  
Secretary for Planning and Environment

*Town and Country Planning Act 1961*  
GEELONG REGIONAL PLANNING SCHEME  
Amendment No. 153

Notice of Amendment

In pursuance of the powers conferred by the *Town and Country Planning Act 1961*, the Lieutenant-Governor in Council on 21 January 1986, amended the abovementioned scheme in respect of the municipal district of the City of Geelong West, and for which the Geelong Regional Commission is the Responsible Authority.

The amendment comes into operation on the date this notice is published in the *Government Gazette*.

The amendment includes zoning of portion of land known as Lunan House, Drumcondra, to Residential 'A', with controls on height of development, and the change of reservation of the balance of the land to Public Open Space (Existing) 'B' Public Park.

A copy of the documents may be inspected free of charge, during office hours, at the office of the Ministry for Planning and Environment, The Oldfleet Buildings, 477 Collins Street, Melbourne and at the office of the Responsible Authority, the Geelong Regional Commission, 5th Floor, State Government Offices, cnr. Lt. Malop and Fenwick Streets, Geelong.

JOHN LAWSON  
Deputy Secretary for Planning and Environment

*Town and Country Planning Act 1961*  
MELBOURNE METROPOLITAN PLANNING  
SCHEME

Amendment No. 305  
Notice of Approval

In pursuance of the powers conferred by the *Town and Country Planning Act 1961*, the Lieutenant-Governor in Council on 21 January 1986, approved the abovementioned scheme in respect of part of the municipal district of the City of Keilor, and for which the Minister for Planning and Environment is the Responsible Authority.

The scheme comes into operation on the date this Notice is published in the *Government Gazette*.

The scheme includes the rezoning of 6.899 ha. of land located on the north side of Taylors Road, west of Oslo Way, Keilor Downs, to Restricted Business and to include it in the Table to Clause 22 (2) of the Ordinance to enable the site to be developed for a shopping centre of up to 12 300 square metres.

A copy of the documents may be inspected free of charge, during office hours, at the office of the Ministry for Planning and Environment, The Oldfleet Buildings, 477 Collins Street, Melbourne.

JOHN LAWSON  
Deputy Secretary for Planning and Environment

*Town and Country Planning Act 1961*  
CITY OF TRARALGON PLANNING SCHEME  
Amendment No. 68  
Notice of Approval

In pursuance of the powers conferred by the *Town and Country Planning Act 1961*, the Lieutenant-Governor in Council on 21 January 1986, approved the abovementioned scheme in respect of the municipal district of the City of Traralgon and for which the City of Traralgon is the Responsible Authority.

The scheme comes into operation on the date this Notice is published in the *Government Gazette*.

The scheme rezones Lot 3, Lodged Plan 146705 and Lot 1, Lodged Plan 143713, Part Crown Allotment A8, Parish of Traralgon from Special Use Zone No. 12—Recreational Buildings to Special Use Zone No. 19—Place of Worship.

A copy of the documents may be inspected free of charge, during office hours, at the office of the Ministry for Planning and Environment, The Olderfleet Buildings, 477 Collins Street, Melbourne, and at the office of the Responsible Authority, City of Traralgon Municipal Offices, Kay Street, Traralgon.

DAVID YENCKEN  
Secretary for Planning and Environment

*Town and Country Planning Act 1961*  
CITY OF HORSHAM PLANNING SCHEME  
Amendment No. 85—Part 1  
Notice of Approval

In pursuance of the powers conferred by the *Town and Country Planning Act 1961*, the Lieutenant-Governor in Council on 21 January 1986, approved the abovementioned scheme in respect of the municipal district of the City of Horsham and for which the City of Horsham is the Responsible Authority.

The scheme comes into operation on the date this Notice is published in the *Government Gazette*.

The scheme rezones the majority of land bounded by Phoebe Crescent, Thomas Street, Gilbert Crescent and Henty Highway from Rural A to Industrial A.

A copy of the documents may be inspected free of charge, during office hours, at the office of the Ministry for Planning and Environment, The Olderfleet Buildings, 477 Collins Street, Melbourne, and at the office of the Responsible Authority, City of Horsham, Civic Centre, Horsham.

DAVID YENCKEN  
Secretary for Planning and Environment

*Town and Country Planning Act 1961*  
CITY OF HORSHAM PLANNING SCHEME  
Amendment No. 104  
Notice of Approval

In pursuance of the powers conferred by the *Town and Country Planning Act 1961*, the Lieutenant-Governor in Council on 21 January 1986, approved the abovementioned scheme in respect of the municipal district of the City of Horsham and for which the City of Horsham is the Responsible Authority.

The scheme comes into operation on the date this Notice is published in the *Government Gazette*.

The scheme will enable the construction of two flats at 20 John Street, Horsham with one or more external walls closer than 3 metres from the side and rear boundary.

A copy of the documents may be inspected free of charge, during office hours, at the office of the Ministry for Planning and Environment, The Olderfleet Buildings, 477 Collins Street, Melbourne, and at the office of the Responsible Authority, City of Horsham, Civic Centre, Horsham.

DAVID YENCKEN  
Secretary for Planning and Environment

*Cemeteries Act 1958*  
SCALE OF FEES OF THE BEULAH PUBLIC  
CEMETERY

In pursuance of the powers conferred upon them by the *Cemeteries Act* the trustees of the Beulah Public Cemetery hereby makes the following scale of fees, which shall come into operation upon publication in the *Government Gazette*, and from and after such publication every scale of fees heretofore made by the said trustees shall be and is hereby rescinded to the extent to which it conflicts with this scale.

<i>Public Graves</i>	\$
Interment in Grave without exclusive right—Stillborn Child	30.00
Interment in Grave without exclusive right—Others	50.00
Number Peg or Label	15.00
<i>Private Graves</i>	
Land, 2.44m × 1.22m	75.00
Own selection of land (extra)	55.00
<i>Sinking Charges for Private Graves</i>	
Sinking grave 1.83m deep	110.00
Each additional 0.3m	25.00
Sinking oversize grave	40.00
Cancellation of order to sink (if commenced)	25.00
Reopening grave (no cover)	110.00
Reopening grave (with cover)	120.00

<i>Miscellaneous Charges</i>		Extra fees for a Saturday, Sunday or Public Holiday burial—	
Interment fee	35.00	(a) Sinking	55.00
Interment outside prescribed hours, or on Saturdays, Sundays or Public Holidays or without due notice	45.00	(b) Ledger removal	33.00
Certificate of Right of Burial	10.00	COUNCIL OF THE SHIRE OF BELLARINE	
Number Plate or Brick	15.00	Approved by the Lieutenant-Governor in Council, 21 January 1986—TIM NEESON, Acting Clerk of the Executive Council	

Permission to erect a headstone or monument—5% of cost with a minimum of \$15.00	
Permission to construct a brick grave or to erect any stone kerb, brick tile-work or concrete—5% of cost with a minimum of \$15.00	
Exhuming the remains of a body (when authorized)	300.00
Interment of ashes in a private grave	35.00
Memorial Wall Niche and Plaque	110.00

J. PHELAN, Trustee  
A. KRANZ, Trustee  
J. HOWIE, Trustee

Approved by the Lieutenant-Governor in Council, 21 January 1986—TIM NEESON, Acting Clerk of the Executive Council

*Cemeteries Act 1958*

SCALE OF FEES OF THE LEOPOLD AND PORTARLINGTON PUBLIC CEMETERY

In pursuance of the powers conferred upon them by the Cemeteries Act the trustees of the Leopold and Portarlington Public Cemetery hereby make the following scale of fees, which shall come into operation upon publication in the *Government Gazette*, and from and after such publication every scale of fees heretofore made by the said trustees shall be and is hereby rescinded to the extent to which it conflicts with the scale.

	\$
Land—Lawn Section	260.00
Land—Monumental Section	130.00
Sinking—any depth to 2.13m	270.00
Sinking oversize grave (extra)	44.00
Ledgers, removal	33.00
Interment or ashes in private grave	40.00
Permission to erect monument, headstone—5% of cost with a minimum of \$10	
Certificate of Right of Burial	13.00
Exhumation (when authorized)	460.00
Interment of ashes in Native Garden (including supply and installation of plaque with three lines of inscription)	100.00
Additional lines of inscription to a maximum of two lines—per line	5.00

*Cemeteries Act 1958*  
SCALE OF FEES OF THE CHEWTON PUBLIC CEMETERY

In pursuance of the powers conferred upon them by the Cemeteries Act the trustees of the Chewton Public Cemetery hereby make the following scale of fees, which shall come into operation upon publication in the *Government Gazette*, and from and after such publication every scale of fees heretofore made by the said trustees shall be and is hereby rescinded to the extent to which it conflicts with this scale.

	\$
Sinking Grave 1.83m deep	120.00

J. R. DAWE, Trustee  
J. PREECE, Trustee  
S. A. ELLERY, Trustee

Approved by the Lieutenant-Governor in Council, 21 January 1986—TIM NEESON, Acting Clerk of the Executive Council

*Cemeteries Act 1958*

SCALE OF FEES OF THE BEALIBA PUBLIC CEMETERY

In pursuance of the powers conferred upon them by the Cemeteries Act the trustees of the Bealiba Public Cemetery hereby make the following scale of fees, which shall come into operation upon publication in the *Government Gazette*, and from and after such publication every scale of fees heretofore made by the said trustees shall be and is hereby rescinded to the extent to which it conflicts with this scale.

	\$
<i>Public Graves</i>	
Interment in Grave without exclusive right—Stillborn Child	30.00
Number Peg or Label	15.00
<i>Private Graves</i>	
Land, 2.44m × 1.22m	75.00
<i>Sinking Charges for Private Graves</i>	
Sinking grave 1.83m deep	110.00
Each additional 0.3m	25.00
Reopening grave (no cover)	110.00
Reopening grave (with cover)	120.00

<i>Miscellaneous Charges</i>			
Interment fee	35.00	Second attachment to special decorative plaque (140mm × 70mm)	50.00
Interment outside prescribed hours, or on Saturdays, Sundays or Public Holidays or without due notice	45.00	Standard lawn: With decorative design and inbuilt flower container (380mm × 280mm)	185.00
Number Plate or Brick	15.00	Standard lawn: With or without inbuilt flower container (380mm × 280mm)	170.00
Permission to erect a headstone or monument—5% of cost with a minimum of \$15.00		<i>Interment of Cremated Remains</i>	
Permission to construct a brick grave or to erect any stone kerb, brick tile-work or concrete—5% of cost with a minimum of \$15.00		Reception of ashes of cremation and placement with a 280mm × 230mm bronze plaque supplied by the Trust at a garden bed	200.00
Exhuming the remains of a body (when authorized)	300.00	<i>Miscellaneous Charges</i>	
Interment of ashes in a private grave	35.00	Exhumation fee (when authorized)	400.00
		Permission to erect, repair or add to any monument	40.00
			J. C. CHILD, Trustee B. HALIT, Trustee C. A. OTTREY, Trustee

Approved by the Lieutenant-Governor in Council, 21 January 1986—TIM NEESON, Acting Clerk of the Executive Council

Approved by the Lieutenant-Governor in Council, 21 January 1986—TIM NEESON, Acting Clerk of the Executive Council

*Cemeteries Act 1958*

SCALE OF FEES OF THE UPPER YARRA PUBLIC CEMETERY

In pursuance of the powers conferred upon them by the Cemeteries Act the trustees of the Upper Yarra Public Cemetery hereby make the following scale of fees, which shall come into operation upon publication in the *Government Gazette*, and from and after such publication every scale of fees heretofore made by the said trustees shall be and is hereby rescinded to the extent to which it conflicts with this scale.

<i>Private Graves</i>		\$
Lawn area, non-denominational. Bronze plaque memorial only, Land, 2.5m × 1.25m, two interments	210.00	
Denominational area. Approved monumental work or bronze plaque, Land, 2.5m × 1.25m, two interments	210.00	
<i>Interment Fees</i>		
Lawn and Monumental areas	150.00	
Ashes in private grave	40.00	
<i>Cemetery Plaque Fees</i>		
Plaques supplied and set in position by the trust.		
Special dual decorative design: To commemorate one or two persons with the same surname. Includes first attachment and inbuilt flower container (560mm × 305mm)	280.00	

*Cemeteries Act 1958*

SCALE OF FEES OF THE TERRAPPEE PUBLIC CEMETERY

In pursuance of the powers conferred upon them by the Cemeteries Act the trustees of the Terraptee Public Cemetery hereby make the following scale of fees, which shall come into operation upon publication in the *Government Gazette*, and from and after such publication every scale of fees heretofore made by the said trustee shall be and is hereby rescinded to the extent to which it conflicts with this scale.

<i>Private Graves</i>		\$
Land, 2.44m × 1.22m	75.00	
<i>Sinking Charges for Private Graves</i>		
Sinking grave 1.83m deep	110.00	
Reopening grave	110.00	
<i>Miscellaneous Charges</i>		
Interment fee	35.00	
Exhuming the remains of a body (when authorised)	300.00	
		G. W. MORES, Trustee E. L. POXON, Trustee L. DOUGLASS, Trustee

Approved by the Lieutenant-Governor in Council, 21 January 1986—TIM NEESON, Acting Clerk of the Executive Council.

I hereby give notice that on 14 January 1986 the Public Trustee filed Elections to Administer the following deceased persons' estates in accordance with section 17 of the *Public Trustee Act 1958*:

Carss, Stanislawa, late of Flat 9, 440 Albion Street, West Brunswick, pensioner, died 26 September 1985.

Cec, Anton, also known as Anthony Cec late of 14 Learmonth Street, Moonee Ponds, storeman, died 5 September 1985.

Cornish, Ida Maud, late of Harcourt Private Nursing Home, 27 Shierlaw Avenue, Canterbury, pensioner, died 4 August 1985.

Cotton, Violet, late of Ararat, pensioner, died 23 September 1985.

Greenwood, William Alexander, late of James Bray Hostel, 24 Wills Street, Melbourne, pensioner, died 30 October 1985.

Hudson, Margaret Mary, late of 44 Malane Street, Ormond, widow, died 6 December 1985.

Rennie, Jessie, late of Ballarat, pensioner, died 19 September 1985.

Rowe, Frances Amy, late of The Queen Elizabeth Geriatric Centre, 102 Ascot Street South, Ballarat, pensioner, died 28 October 1985.

Sanfead, Mavis Adele, late of Kew, pensioner, died 10 November 1985.

Woollock, Adelaide Annie, formerly of "Gladeswood" 16 Rothwell Street, Ascot Vale but late of Dorset Private Hospital, 146 Derby Street, Pascoe Vale, pensioner, died 8 October 1985.

Melbourne, 22 January 1986  
168 Exhibition Street,  
Melbourne

P. T. SPENCER  
Public Trustee

I hereby give notice that on 15 January 1986 the Public Trustee filed Elections to Administer the following deceased persons' estates in accordance with section 17 of the *Public Trustee Act 1958*:

Baldwin, Doris Clare, formerly of 6 Argyle Avenue, Chelsea but late of Kingston Centre, Warrigal Road, Cheltenham, spinster, died 18 July 1985.

Buckland, William Roy, formerly of "Accadia Lodge", 11K Raleigh Street, Windsor, but late of Happy Lodge, 134 Alma Road, East St. Kilda, pensioner, died 19 September 1985.

Carter, Gladys Lillian, formerly of Flat 22/20 Elgin Street, Carlton, but late of Flat 14/44 Terama Crescent, Bayswater, widow, died 7 July 1985.

Maysen, Paul, also known as Paul Mason, late of 10/11 Anderson Street, South Melbourne, cleaner, found dead on 21 October 1985.

Nan Tie, Gwenneth, late of Sunbury, pensioner, died 8 November 1985.

Pincott, Grace Ada, formerly of 562 Main Road, Wattle Glen, but late of Rosebud, pensioner, died 18 September 1985.

Sheedy, Annie Teresa, late of Flat 209/49 Union Street, Windsor, widow, died 21 November 1985.

Stanko, Michael, formerly of 3 Eumeralla Road, Caulfield South, but late of Bundoora, pensioner, died 15 November 1985.

Wainwright, Ethel, formerly of 20 Fernhill Road, Sandringham, but late of 7 Mair Street, Brighton Beach, pensioner, died 29 August 1985.

Melbourne 22 January 1986  
168 Exhibition Street, Melbourne

P. T. SPENCER  
Public Trustee

Creditors, next of kin and others having claims against the estate of the under-mentioned deceased persons are required to send particulars of their claims to the Public Trustee, 168 Exhibition Street, Melbourne, Vic. 3000, the personal representative, on or before 3 April 1986 after which date the Public Trustee may convey or distribute the assets having regard only to the claims of which the Public Trustee then has notice:

Baldwin, Doris Clare, formerly of 6 Argyle Avenue, Chelsea but late of Kingston Centre, Warrigal Road, Cheltenham, spinster, died 18 July 1985.

Buckland, William Roy, formerly of "Accadia Lodge", 11K Raleigh Street, Windsor but late of Happy Lodge, 134 Alma Road, East St. Kilda, Pensioner, died 19 September 1985.

Carss, Stanislawa, late of Flat 9, 440 Albion Street, West Brunswick, Pensioner, died 26 September 1985.

Carter, Gladys Lillian, formerly of Flat 22/20 Elgin Street, Carlton but late of Flat 14/44 Terama Crescent, Bayswater, widow, died 7 July 1985.

Cec, Anton also known as Anthony Cec, late of 14 Learmonth Street, Moonee Ponds, Storeman, died 5 September 1985.

Coman, Owen, late of 86 Pleasant Road, Hawthorn East, retired Public Servant, died 1 December 1985.

Cornish, Ida Maud, late of Harcourt Private Nursing Home, 27 Shierlaw Avenue, Canterbury, pensioner, died 4 August 1985.

Cotton, Violet, late of Ararat, pensioner, died 23 September 1985.

Greenwood, William Alexander, late of James Bray Hostel, 24 Wills Street, Melbourne, pensioner, died 30 October 1985.

Hague, Peter, late of 2 Fernside Avenue, Briar Hill, metal worker, found dead 2 November 1985.

Hudson, Margaret Mary, late of 44 Malane Street, Ormond, widow, died 6 December 1985.

Kelly, Brian Edmund, late of 18 Somerset Close, Werribee, Clerk, died 5 October 1985.

McGinley, Florence Alice, late of 38 Cromwell Street, Collingwood, married woman, died 5 September 1985.

MacCormick, Ethel Amelia late of Auckland, New Zealand, widow, died 26 April 1985.

Maher, Lucy Margaret, late of 13 McConnell Street, Kensington, widow, died 22 November 1985.

Maysen, Paul also known as Paul Mason, late of 10/11 Anderson Street, South Melbourne, Cleaner, found dead on 21 October 1985.

Nan Tie, Gwenneth, late of Sunbury, pensioner, died 8 November 1985.

Pincott, Grace Ada, formerly of 562 Main Road, Wattle Glen, Rosebud, pensioner, died 18 September 1985.

Rennie, Jessie, late of Ballarat, pensioner, died 19 September 1985.

Rowe, Frances Amy, late of The Queen Elizabeth Geriatric Centre, 102 Ascot Street South, Ballarat, pensioner, died 28 October 1985.

Sanfead, Mavis Adele, late of Kew, pensioner, died 10 November 1985.

Sheedy, Annie Teresa, late of Flat 209/49 Union Street, Windsor, widow, died 21 November 1985.

Stanko, Michael, formerly of 3 Eumeralla Road, Caulfield South, but late of Bundoora, pensioner, died 15 November 1985.

Tricarico, Luigi, late of Perpetua Private Nursing Home, 673 Lygon Street, North Carlton, retired, died 7 August 1985.

Trivett, Agnes Aitken, formerly of 68 Sydney Road, Brunswick but late of Parkville, retired toolmaker, died 1 April 1985.

Wainwright, Ethel, formerly of 20 Fernhill Road, Sandringham but late of 7 Mair Street, Brighton Beach, pensioner, died 29 August 1985.

Williams, Gladys Ruby, formerly of 3/1 Edinburgh Street, Hampton but late of Mahogany Lodge, 26 Service Street, Hampton, home duties, died 27 July 1985.

Woolcock, Adelaide Annie, formerly of "Gladeswood" 16 Rothwell Street, Ascot Vale but late of Dorset Private Hospital, 146 Derby Street, Pascoe Vale, pensioner, died 8 October 1985.

Melbourne, 22 January 1986

P. T. SPENCER  
Public Trustee

*Water and Sewerage Authorities (Restructuring)  
Act 1983*

SEWERAGE DISTRICTS ACT 1958

Dandenong-Springvale Water Board

Fixing the Limit of Bank Overdraft

His Excellency the Lieutenant-Governor of the State of Victoria by and with the advice of the Executive Council thereof has by Order made on

21 January 1986, fixed, under the provisions of sections 78, 79 and 79A of the *Sewerage Districts Act 1958*, the total amount of the sums that the Dandenong/Springvale Water Board may owe at any one time in respect of monies borrowed by overdraft of general account at \$100,000.

TIM NEESON

Acting/Clerk of the Executive Council

At the Executive Council Chamber

Melbourne 21 January 1986

*Water and Sewerage Authorities (Restructuring)  
Act 1983*

SEWERAGE DISTRICTS ACT 1958

Hindmarsh Water Board

Fixing the limit of bank overdraft

His Excellency the Lieutenant Governor of the State of Victoria by and with the advice of the Executive Council thereof has by Order made on 21 January 1986, fixed, under the provisions of sections 78, 79 and 79A of the *Sewerage Districts Act 1958*, the total amount of the sums that the Hindmarsh Water Board may owe at any one time in respect of monies borrowed by overdraft of general account at \$100,000.

TIM NEESON

Acting Clerk of the Executive Council

At the Executive Council Chamber

Melbourne, 21 January 1986

*Transport Act 1983*

DECLARATION OF ROADS BY THE  
MINISTER FOR TRANSPORT

The Minister for Transport for the State of Victoria declares the roads or parts of roads or any deviations from or widenings of roads as described below—

*State Highways*

1/86—Declaration of the widening of the Hamilton Highway in the Shire of Mortlake as shown hatched on plan numbered G.P. 16584B.

2/86—Declaration of the widening of the Maroondah Highway in the Shire of Lillydale as shown hatched on plan numbered G.P. 15964B.

3/86—Declaration of the widening of the Princes Highway in the Cities of Caulfield and Malvern as shown hatched on plan numbered G.P. 15798D.

*Main Roads*

4/86—Declaration of the widening of Highlands Road in the Shire of Seymour as shown hatched on plan numbered G.P. 16302B.

5/86—Declaration of the widening of the Ballan-Meredith Road in the Shire of Ballan as shown hatched on plan numbered G.P. 15550B.

6/86—Declaration of the widenings of Kororoit Creek Road in the Cities of Altona and



Williamstown as shown hatched on plans numbered G.P. 7396C, G.P. 7396D, G.P. 7843E, G.P. 7843F, G.P. 7843G, G.P. 7843H and G.P. 7798B.

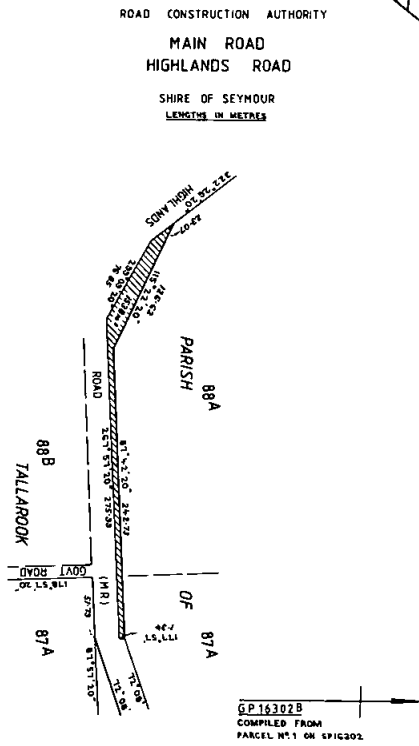
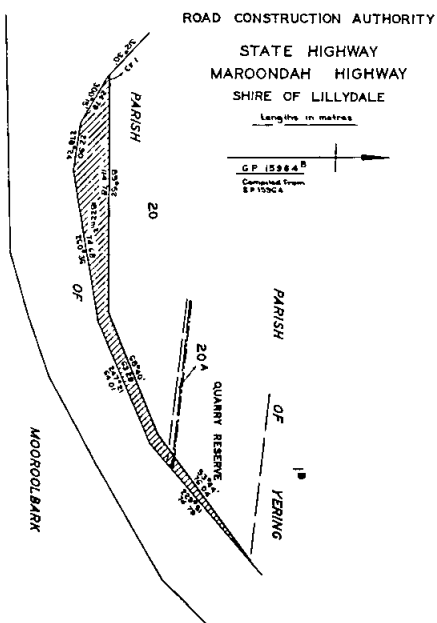
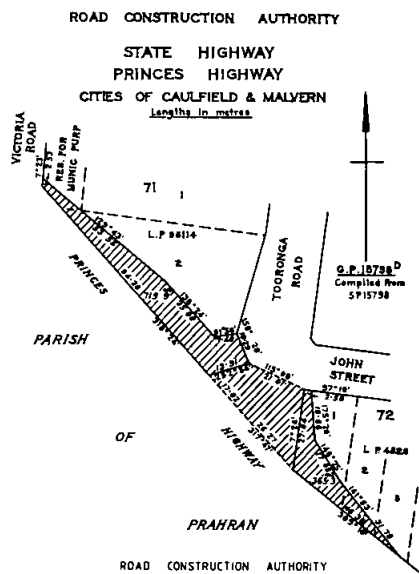
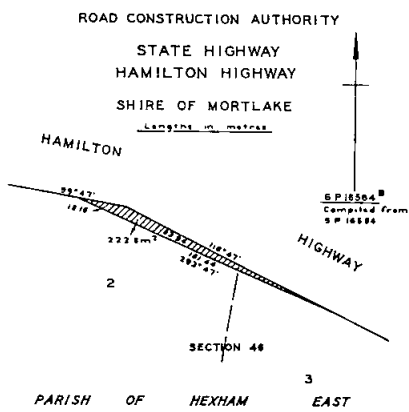







ROAD CONSTRUCTION AUTHORITY  
MAIN ROAD  
KOROROIT CREEK ROAD  
CITY OF WILLIAMSTOWN  
LENGTHS IN METRES

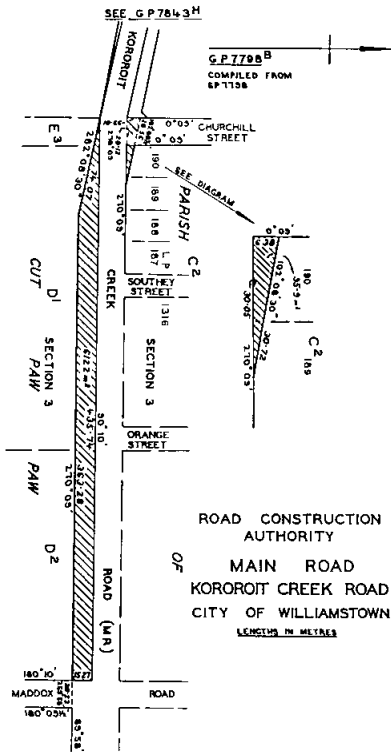
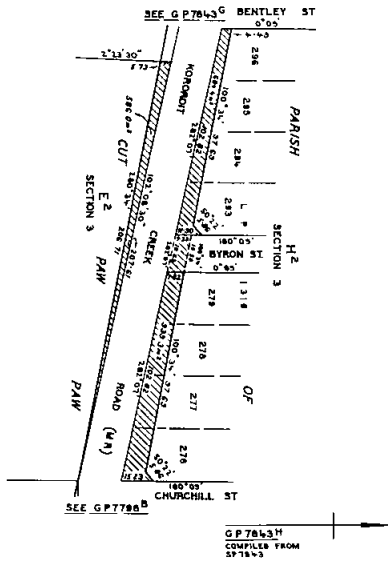

7/86—Declaration of the widening of the Baxter-Tooradin Road in the Shire of Cranbourne as shown hatched on plan numbered G.P. 14810B.

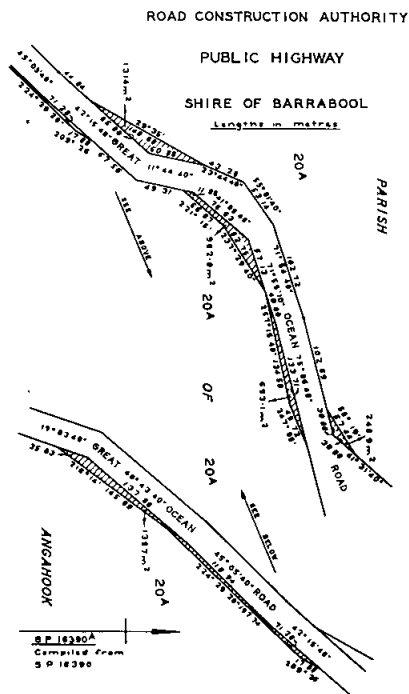
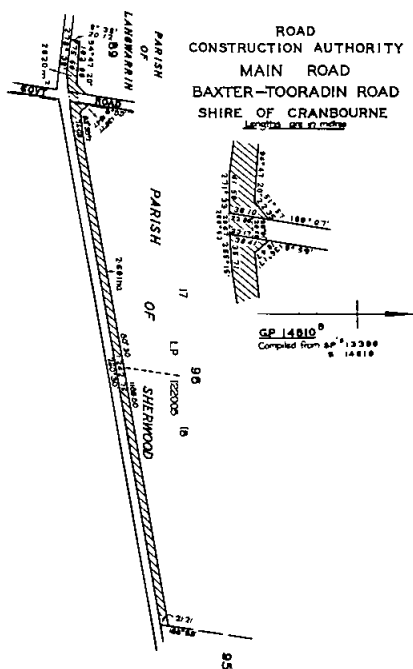

Dated 20 January 1986

T. W. ROPER  
Minister for Transport

*Transport Act 1983*

**NOTICE DECLARING THE WIDENINGS OF EXISTING ROADS TO BE FIT TO BE USED AS PUBLIC HIGHWAYS**

The Road Construction Authority is of the opinion that the widenings of the existing roads as set out below are fit to be used as public highways—

The widenings of an existing road in the Shires of Barrabool and Otway as shown hatched on plans numbered G.P. 16390A and G.P. 16597A.

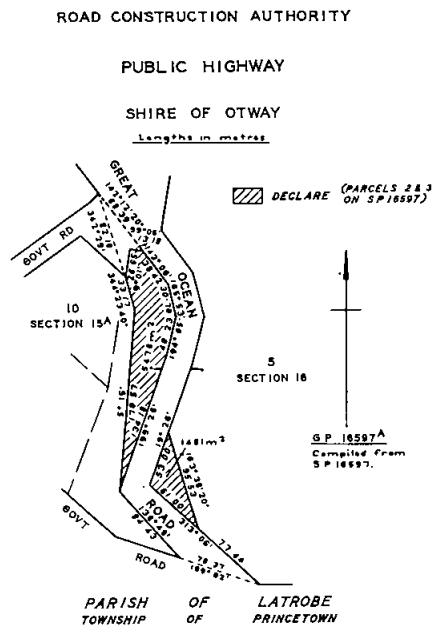

In accordance with the provisions of Clause 2 (2), Schedule 5 of the *Transport Act 1983*, the widenings shall, upon the publication of this notice in the *Government Gazette*, become and be absolutely dedicated to the public as public highways within the meaning of any law now or hereafter in force.  
Dated 22 January 1985

T. H. RUSSELL  
Chairman and Managing Director

PROPOSED REVOCATION OF TEMPORARY RESERVATION OF LAND BY ORDER IN COUNCIL

In pursuance of the provisions of section 10 of the *Crown Land (Reserves) Act 1978*, notice is hereby given that it is the intention of the Governor in Council to revoke the temporary reservation of land by Order in Council hereunder referred to, viz.:

**COBURG**—The temporary reservation by Order in Council of 17th January 1967 of 4426 square metres of Land in the Township of Coburg as a site for Public Recreation so far only as the portion containing 861 square metres being Crown allotment 30A, Township of Coburg, as shown on plan CP 107632, lodged with the Central Plan Office (Rs. 8553).

**DERGHOLM**—The temporary reservation by Order in Council of 29 October 1985, of 2.7 hectares, more or less, being Crown allotment 39 Parish of Dergholm as a site for a State School Forest Plantation (D177(5)) (Rs. 13141).

**BALLARAT WEST**—The Ballarat West Town Common proclaimed as such by the Governor in Council on 28 January 1981, so far as regards the portion comprising 11.03 hectares shown as Crown allotment 12 section 3, Parish of Dowling Forest on Certified Plan No. 107515 lodged in the Central Plan Office. (Parish 2542) (C 91998).

**BALLARAT**—The temporary reservation by Order in Council of 7 May 1957 of 19 hectares of land in the Township of Ballarat for Municipal Depot and Municipal Sale Yards, revoked as to part by various Orders, so far only as regards the portion thereof containing 8851 m<sup>2</sup> as indicated by hatching on plan hereunder, is concerned.—(B128 (67)) (Rs. 1253).

MUNICIPAL DEPOT AND SALE YARDS RES.

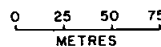
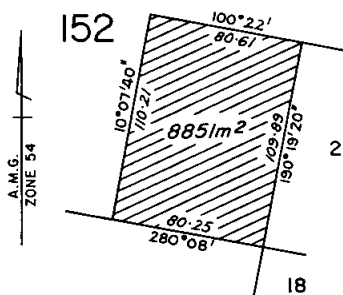

**MIRBOO (Boolarra)**—The temporary reservation by Order in Council of 2 March 1983 of 4306 square metres of land in the Parish of Mirboo for Municipal Storeyard purposes so far only as regards the portion containing 207 square metres, as indicated by hatching on plan hereunder. (M 517 (16)) (Rs. 12299).

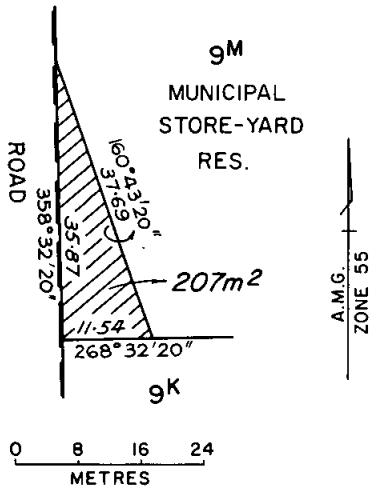

CO-OPERATION ACT 1981  
 Small Holders Co-operative Limited  
 Templestowe Pre-School Co-operative Limited  
 Watsonia Heights Primary School Co-operative Limited

Notice is hereby given in pursuance of section 192 (8) of the *Co-operation Act* 1981 and section 459 (2) of the *Companies (Victoria) Code*, that, at the expiration of three months from the date hereof, the names of the aforementioned societies will, unless cause is shown to the contrary, be struck off the register and the societies will be dissolved.

Dated at Melbourne 16 January 1986  
 W. J. KILPATRICK  
 Registrar of Co-operative Societies

ASSOCIATIONS INCORPORATION ACT 1981  
 Notice is hereby given that in pursuance of subsection 10 (4) of the *Associations Incorporation Act* 1981 a certificate of incorporation was granted to Christian Alternative to Remand Accommodation Limited on 31 December 1985.

JOHN B. KING  
 Registrar of Incorporated Associations

HAMILTON—The temporary reservation by Order in Council of 23 November 1868 of land in the Township of Hamilton as a site for Railway Reserve so far only as the portion containing 5360 square metres indicated by hatching on plan hereunder (H 45 (3)) L2 1377.

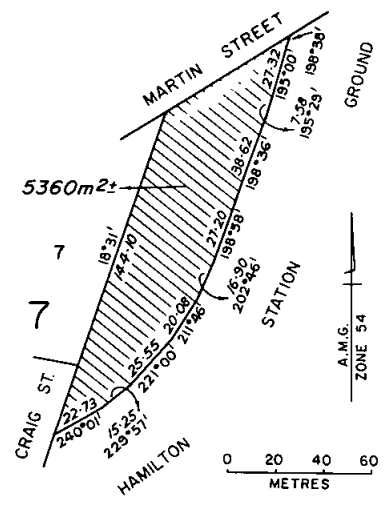

MITTA MITTA RIVER IMPROVEMENT TRUST  
 By-Law No. 32

The Mitta Mitta River Improvement Trust in pursuance and exercise of the powers conferred by the *River Improvement Act* 1958, doth hereby make the By-law following:

1. The following rate, to be called the "Mitta Mitta River Improvement District River Improvement Rate" is hereby made and shall be levied upon the occupiers or owners of all properties within the Mitta Mitta River Improvement Trust District which are rateable to any municipality.

A rate of one hundred and seventy five thousandths of a cent in the dollar on the site value of all those properties within the First Division, as determined by the Order in Council made on 1 February 1961, and published in the *Government Gazette* on 18 February 1961.

A rate of eight hundred and seventy five ten thousandths of a cent in the dollar on the site value of all those properties within the Second Division, as determined by the said Order in Council.

No rate on all those properties within the Third Division, as determined by the said Order in Council.

2. The minimum rate in the First and Second Divisions shall be four dollars.

3. Such rates are made and shall be levied for the period beginning with 1 January 1986 and ending with 31 December 1986, and shall be payable on 1 July 1986 at the office of the Mitta Mitta River Improvement Trust, Tallangatta.

J. E. KIRNER  
 Minister for Conservation, Forests and Lands



4. Such person or persons as the Mitta Mitta River Improvement Trust may from time to time appoint for that purpose shall be and is or are authorized to demand, receive, collect and recover the said rate.

5. Interest will be charged on all rates remaining unpaid after 31 October 1986.

The foregoing By-law was made by the Mitta Mitta River Improvement Trust on 20 December 1985, and the common seal of the Trust was hereunto affixed, on 20 December 1985, in the presence of—

R. FRASER PATON, Chairman  
LEONARD R. PETERS, Commissioner  
H. R. CRAIG, Secretary

Approved 14 January 1986—A. McCUTCHEON,  
Minister for Water Resources

#### FARM PRODUCE MERCHANTS AND COMMISSION AGENTS ACT 1965 (No. 7274)

List of names and addresses of licence holders to whom licences have been issued during December 1985. In accordance with the above Act, those issued with a Merchant's licence have paid the prescribed contribution to the Farm Produce Merchants and Commission Agents Guarantee Fund. All licences, unless earlier surrendered or cancelled, shall continue in force until 30 June 1986.

##### Merchants

Ferraro & Madafferi Fruit Merchants P/L, Store 63 'B', Melbourne Wholesale Fruit and Vegetable Market, Footscray, Vic. 3011

Glynn Harvey Pty. Ltd., 69 Sea Beach Parade, North Shore, Vic. 3214.

Hong Oriental Food Pty. Ltd., 14-22 Heffernan Lane, Melbourne, Vic. 3000.

##### Secondary Wholesaler

Thompson, K. N., 85 Vines Road, Hamlyn Heights, Vic. 3218.

D. E. HORE

Acting Director General of Agriculture and Rural Affairs

#### Farm Produce Merchants and Commission Agents Act 1965 (No. 7274)

##### TRANSFER OF LICENCE

The Merchants licence issued to Bernard Keith Raymond, trading as Mildura and South Australia Fruit Company at Stores 390-391, Melbourne Wholesale Fruit and Vegetable Market, Footscray Road, Footscray, 3011, has been transferred to Mr. Chayben Haykal.

D. E. HORE

Acting Director General of Agriculture and Rural Affairs

#### DRAINAGE AREAS ACT 1958

Notice of Approval of special maintenance charge made by the Council of the Shire of Otway in respect of the Aire River Drainage Area

Notice is hereby given that on 21 January 1986 in accordance with the provisions of section 36 of the *Drainage Areas Act 1958*, The Lieutenant-Governor in Council approved the estimate of the cost of proposed maintenance works in the Aire River Drainage Area submitted by the Council of the Shire of Otway and the making by the Council of a special maintenance charge on properties within the said Drainage Area for the year ending 30 September 1986.

TIM NEESON

Acting Clerk of the Executive Council

#### TOWNSHIP OF MALDON DIMINISHED

His Excellency the Lieutenant-Governor of the State of Victoria by and with the advice of the Executive Council thereof has by Order made on 21 January 1986, approved pursuant to the provisions of section 25 (3) (d) of the *Land Act 1958*, that the Township of Maldon in the Parish of Maldon, proclaimed as such on 1 July 1952 (see *Government Gazette* dated 9 July 1952, page 3587) be diminished, by notice published in the *Government Gazette*, by the excision therefrom of the portion as indicated by hatching on plan hereunder M 449 (12) C 8193.

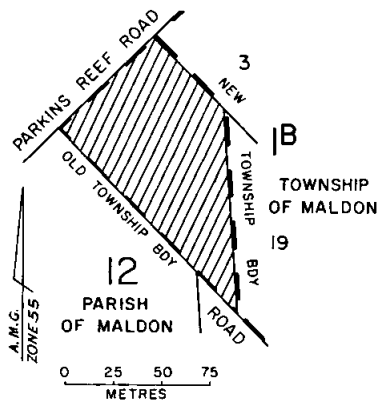

TIM NEESON

Acting Clerk of the Executive Council

SHIRE OF NARRACAN  
Road Deviation

Pursuant to the provisions of sections 522 and 526 of the *Local Government Act 1958* the Council of the Shire of Narracan hereby directs that the land in the Parish of Tanjil indicated by hatching on the plan hereunder which has been purchased, taken or acquired by it, shall be a public highway on and from the date of publication of this order in the *Government Gazette* and declares that such land shall be a public highway in lieu of the land indicated by cross-hatching on the said plan.

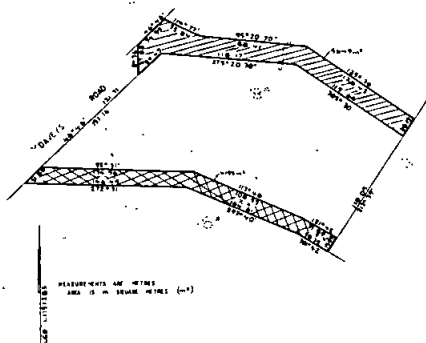

The common seal of the President Councillors and Ratepayers of the Shire of Narracan was hereunto affixed 11 December 1985 in the presence of—

W. A. J. HORNER, President  
E. J. KEATING, Councillor  
D. STEVENS, Secretary

Confirmed by the Lieutenant-Governor in Council, 21 January 1986—TIM NEESON, Acting Clerk of the Executive Council.

APPOINTMENTS AND  
RESIGNATIONS

APPOINTMENTS

His Excellency the Lieutenant-Governor of the State of Victoria by and with the advice of the Executive Council thereof has by Order made on 21 January 1986 been pleased to make the undermentioned appointments, viz:

DEPARTMENT OF HEALTH  
*Deputy Psychiatrist Superintendent*

Mary CAMERON,  
to be Deputy Psychiatrist Superintendent, Bendigo Psychiatric and Mental Hospital, pursuant to section 26, (1) of the *Mental Health Act 1959* from 29 October 1985.

*Trustee of Public Cemeteries*

Eric WEBB,

to be a Trustee of the Bridgewater Cemetery Trust; additional trustee

Ian Alexander GRANT,

to be a trustee of the Redbank Cemetery Trust; additional trustee

Malcolm ARCHER,

Shirley ARCHBOLD, and

Ian MALTBY,

to be trustees of the Chewton Cemetery Trust; additional trustees

Kevin POYSER,

George JENKINS,

George CORDY, and

John COGHLAN,

to be trustees of the Bridgewater Old Cemetery Trust; additional trustees.

All appointments made pursuant to section 3 (1) of the *Cemeteries Act 1958*.

*Hospitals Accreditation Committee*

Mary Patricia WILKINSON, B.Sc., M.D., B.S.,  
F.R.C.P., F.R.A.C.P.,

to be a member of the Hospitals Accreditation Committee pursuant to the provisions of section 7A of the *Medical Practitioners Act 1970* for the period ending 24 September 1988.

*Chiropractors and Osteopaths Registration Board*

Simon John WILLIAMS,

to be a member and Chairman of the Chiropractors and Osteopaths Registration Board of Victoria, pursuant to the provisions of section 3 of the *Chiropractors and Osteopaths Act 1978* for the period ending 1 July 1987.

LAW DEPARTMENT

*Administrative Appeals Tribunal*

Brian P. McCARTHY,

Michael D. HIGGINS, and

Elizabeth H. CURTIN,

to be part time members of the Administrative Appeals Tribunal pursuant to section 6 (2) of the *Administrative Appeals Tribunal Act 1984*, for a further period of three years from 1 February 1986.

*Stipendiary Magistrate*

Robert Krishnan Ashok KUMAR,

to be a Stipendiary Magistrate pursuant to section 7 (1) of the *Magistrates' Courts Act 1971*, from 3 March 1986.

TIM NEESON

Acting Clerk of the Executive Council

At the Executive Council Chamber  
Melbourne, 21 January 1986

**RESIGNATIONS**

His Excellency the Lieutenant-Governor of the State of Victoria by and with the advice of the Executive Council thereof has by Orders made on 21 January 1986 accepted the resignations of the persons named hereunder of the offices mentioned, viz.:

**Department of Health**

*Members of the Committee of Management of Hospitals*

John Phillip WEBB

as Member of the Committee of Management Cobram District Hospital as from 23 October 1985.

Kevin Patrick McCARTHY

as Member of the Committee of Management, Heathcote District Hospital as from 16 December 1985.

in accordance with the provisions of section 63G (1) of the *Hospitals and Charities Act 1958*.

TIM NEESON

Acting Clerk of the Executive Council

At the Executive Council Chamber, Melbourne, 21 January 1986

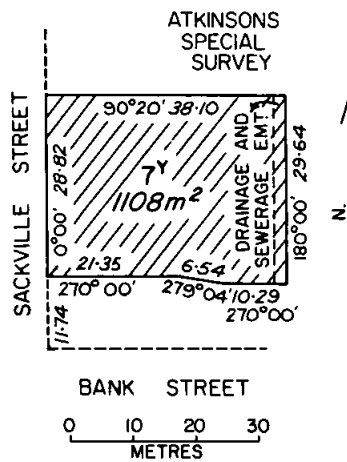

Municipal District of the Shire of Arapiles—Darragan—for supply of Stone and other materials—2.104 hectares being Crown allotment 120A, Parish of Darragan, as indicated by hatching on plan hereunder—(D187(3)) (Rs.13040).

**ORDERS IN COUNCIL**

**CROWN LAND (RESERVES) ACT 1978**

At the Executive Council Chamber, Melbourne, the twenty-first day of January 1986

PRESENT:

His Excellency the Lieutenant-Governor of Victoria

Mr White  
Mr Jolly

Mrs Hogg

**CROWN LANDS TEMPORARILY RESERVED**

His Excellency the Lieutenant-Governor of the State of Victoria, in the Commonwealth of Australia, by and with the advice of the Executive Council of the said State, pursuant to the provisions of sections 4 and 7 of the *Crown Land (Reserves) Act 1978*, and being of the opinion that the Crown lands concerned are required for the purposes respectively mentioned, hereby temporarily reserves and also exempts from prospecting or from occupation for mining purposes under any miner's right the Crown lands hereinafter described, viz.:

Municipal District of the Borough of Port Fairy—Belfast—for Departmental Depot—1108 square metres being Crown allotment 7Y Parish of Belfast as indicated by hatching on plan hereunder—(Parish 2105) (Rs.12717).

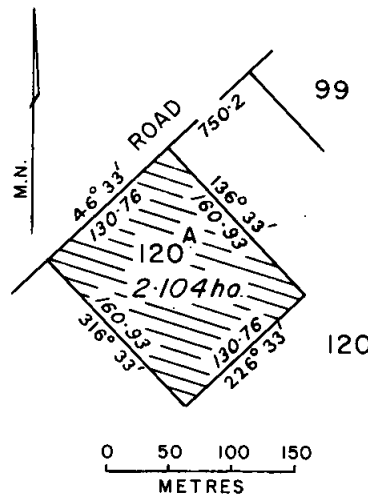

Municipal District of the Shire of Avoca—Glenmona—for supply of Gravel and Stone—15 hectares, more or less being Crown allotment 14E, section E, Parish of Glenmona, as indicated by hatching on plan hereunder—(G155(3)) (Rs.3723).

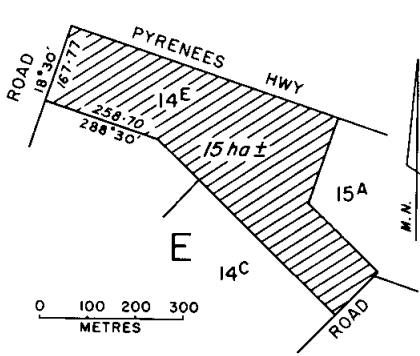

Municipal District of the Shire of Hampden—Glenormiston—for Departmental Residence—1119 square metres being Crown allotment 3A, Parish of Glenormiston, as indicated by hatching on plan hereunder—(G88(2)) (Rs.12555).

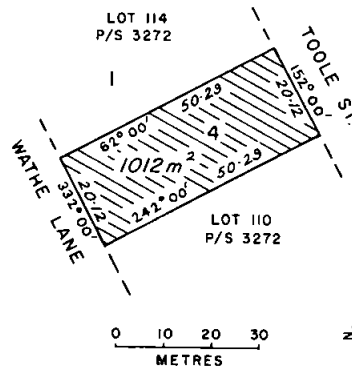

Municipal District of the City of Northcote—Jika Jika—for Health Purposes—501 square metres, being Crown allotment 114B, Parish of Jika Jika, as indicated by hatching on plan hereunder—(J16(4)) (Rs.13021).

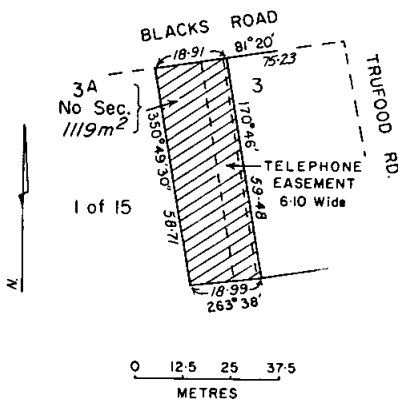

Municipal District of the Shire of Karkaroc—Hopetoun—for a Court House—1012 square metres, being Crown allotment 4, Township of Hopetoun, Parish of Goyura, as indicated by hatching on plan hereunder—(G202(7)) (Rs.12967).

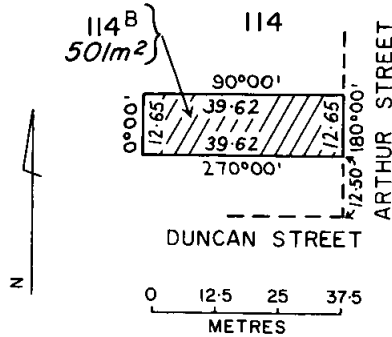

Municipal District of the Shire of Numurkah—Katunga—for Drainage purposes—3900 square metres, more or less, being Crown allotments 2A and 2B, section A, Parish of Katunga, as indicated by hatching on plan hereunder—(K166(3)) (Rs.9983).

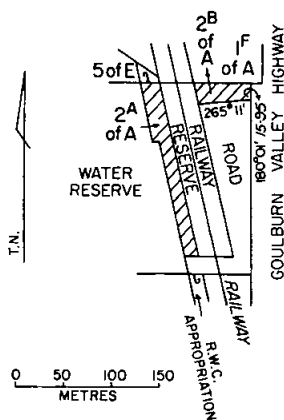

Total area of hatched portions 3900m<sup>2</sup> ±

Municipal District of the Shire of Marong—Mandurang—for Water Supply purposes—605 square metres, being Crown allotment 96B, section D, Parish of Mandurang, as indicated by hatching on plan hereunder—(M29(10)) (Rs.12657).

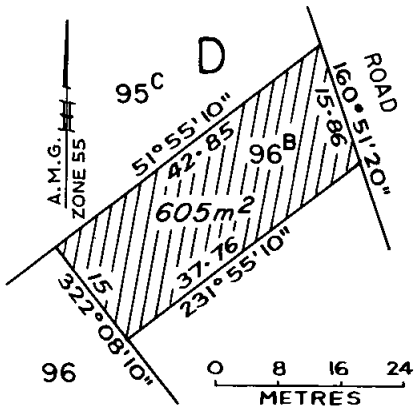

Municipal District of the City of Melbourne—Melbourne—for Plantation and Children's Playground—3329 square metres, being Crown allotment 11, section K, at West Melbourne, City of Melbourne, Parish of Melbourne North as indicated by hatching on plan hereunder—(M314(10)) (Rs.7166).

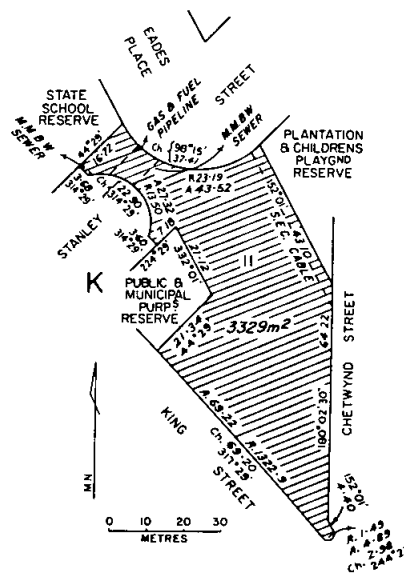

Municipal District of the Shire of Glenelg—Merino—for Hospital purposes—8094 square metres, being Crown allotment 3A, section 6, Township of Merino, as indicated by hatching on plan hereunder—(M248(4)) (Rs.6325).

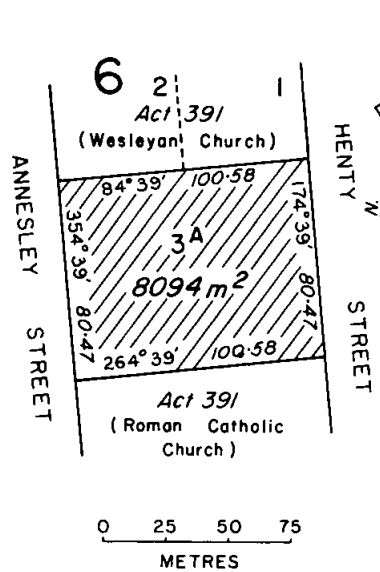

Municipal District of the Shire of Corio—Moorpanyal—for Health purposes—776 square metres, being Crown allotment 96A, Parish of Moorpanyal, as indicated by hatching on plan hereunder—(Parish 3179) (Rs.12683).

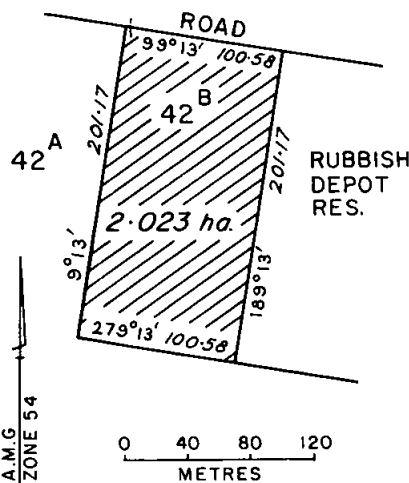
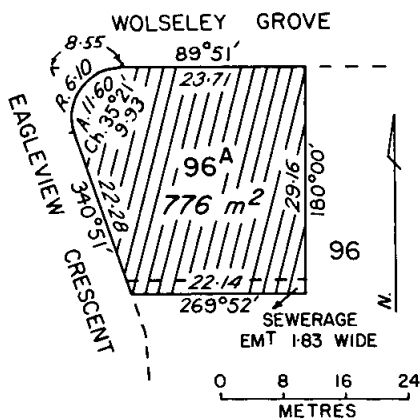

Municipal District of the City of Box Hill—Nunawading—for Health purposes—1033 square metres, being Crown allotment 6, section A, Parish of Nunawading, as indicated by hatching on plan hereunder—(N79(7)) (Rs.12565).

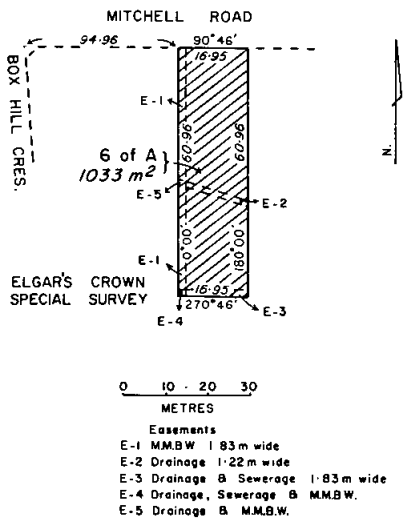

Municipal District of the Shire of Rodney—Murchison North—for Community Welfare purposes—25.61 hectares, being Crown allotment 94C, Parish of Murchison North, as indicated by hatching on plan hereunder—(M273(10)) (Rs.8451).

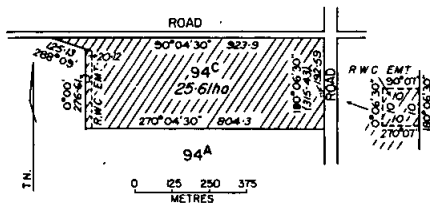

Municipal District of the Shire of Wycheproof—Nullawil—for Rubbish Depot—2.023 hectares, being Crown allotment 42B, Parish of Nullawil, as indicated by hatching on plan hereunder—(N160(2)) (Rs.1097).

Municipal District of the Shire of Karkaroc—Patchewollock—for Departmental Residence—1012 square metres, being Crown allotment 27C, Parish of Patchewollock, as indicated by hatching on plan hereunder—(P146(7)) (Rs.12857).

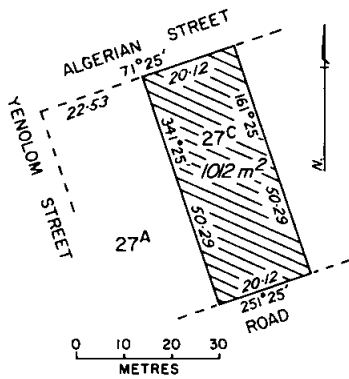

Municipal District of the City of Bendigo—Sandhurst—for Health purposes—1027 square metres, being Crown allotment 2A, section 56B, at Bendigo, Parish of Sandhurst, as indicated by hatching on plan hereunder—(S372(117)) (Rs.12592).

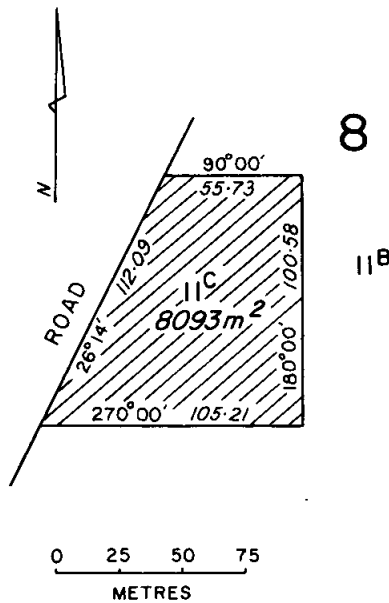

Municipal District of the City of Swan Hill—Swan Hill—for Health purposes—583 square metres, being Crown allotment 1A, section 34, Township of Swan Hill, Parish of Castle Donnington as indicated by hatching on plan hereunder—(S464 (4)) (Rs.12889).

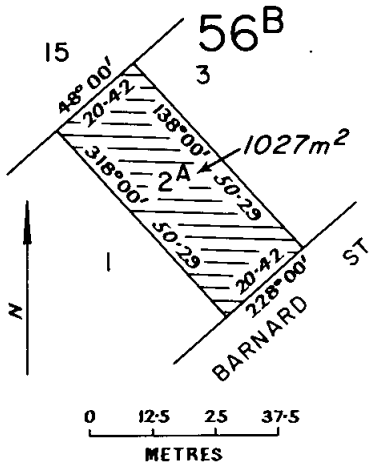

Municipal District of the Shire of Avon—Stratford—for the supply of Gravel—8093 square metres, being Crown allotment 11C, section 8, Parish of Stratford, as indicated by hatching on plan hereunder—(Parish 3504-1) (Rs.12966).

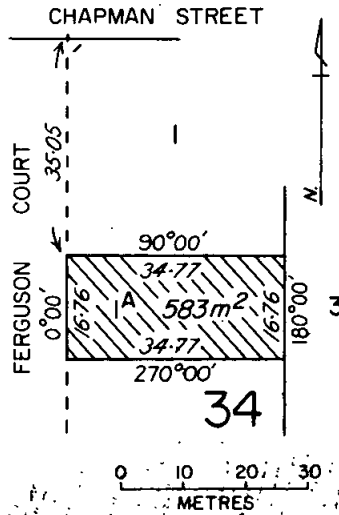

Municipal District of the Shire of Warrnambool—Tallangatta—for Police purposes—1707 square metres, being Crown allotment 1C, Parish of Tallangatta, as indicated by hatching on plan hereunder—(Parish 3530) (Rs.12931).

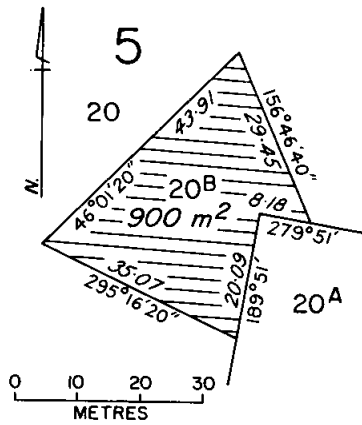
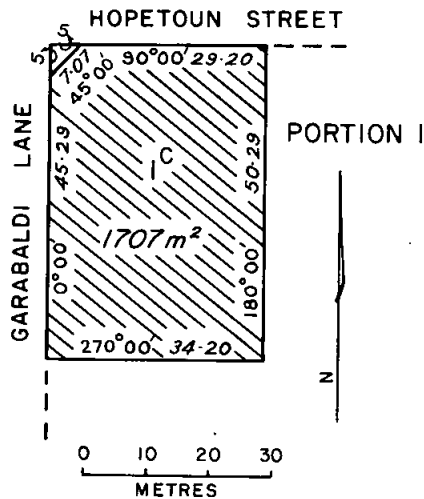

And the Honourable Joan Elizabeth Kirner, Her Majesty's Minister for Conservation, Forests and Lands for the State of Victoria, shall give the necessary directions herein accordingly.

TIM NEESON  
Acting Clerk of the Executive Council

Municipal District of the Shire of Maffra—Tinamba—for the Supply of Gravel—2.022 hectares, being Crown allotment 14B, Section A, Parish of Tinamba, as indicated by hatching on plan hereunder—(T147(4)) (Rs.12953).

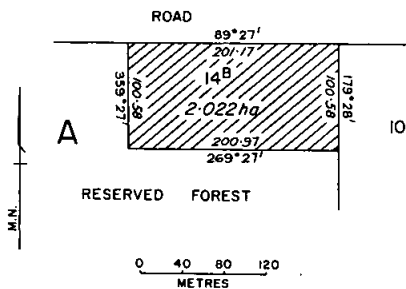

*Crown Land (Reserves) Act 1978*

At the Executive Council Chamber, Melbourne, the twenty-first day of January 1986

PRESENT:

His Excellency the Lieutenant-Governor  
of Victoria

Mr White | Mrs Hogg  
Mr Jolly |

**CROWN LANDS TEMPORARILY RESERVED**

His Excellency the Lieutenant-Governor of the State of Victoria, in the Commonwealth of Australia, by and with the advice of the Executive Council of the said State, pursuant to the provisions of sections 4 and 7 of the *Crown Land (Reserves) Act 1978*, and being of the opinion that the Crown lands concerned are required for the purposes respectively mentioned, hereby reserves and also excepts from prospecting or from occupation for mining purposes under any miner's right the Crown lands hereinafter described, viz:

Municipal District of the Shire of Bright—Freeburgh—for State School Forest Plantations—3.962 hectares, being Crown allotments 6C and 6D,

Municipal District of the Shire of Bairnsdale—Wy-Yung—for Police purposes—900 square metres, being Crown allotment 20B, section 5, Parish of Wy-Yung, as indicated by hatching on plan hereunder—(W 236 (13)) (Rs.12774).



Township of Freeburgh, Parish of Freeburgh as shown on Certified Plan No. 107525 lodged in the Central Plan Office—(F95(11)) (Rs. 13087)

Municipal District of the Shire of Alberton—Woodside—for Public Recreation—1.5 hectares, more or less, being Crown allotment 7, section 1A, Township of Woodside, Parish of Woodside, as shown on Certified Plan No. 107553 lodged in the Central Plan Office—(W217(8)) (Rs. 4043)

Municipal District of the Shire of Werribee—Hoppers Crossing—for Conservation of an Area of Historic Interest—749 square metres, being Crown allotment 28, section 16, Parish of Deulgam, as shown on Certified Plan No. 106423 lodged in the Central Plan Office—(2518) (Rs. 13107)

Municipal District of the Shire of Mildura—Red Cliffs—for Cemetery purposes—3.461 hectares, being Crown allotment 490F, section B, Parish of Mildura, as shown on Certified Plan No. 107597 lodged in the Central Plan Office—(M556(23)) (Rs. 13121)

Municipal District of the Shire of Charlton—Charlton—for State School purposes—23.14 hectares, being Crown allotment 2, section 14, Township of Charlton, Parish of Charlton East, as shown on Certified Plan No. 107527 lodged in the Central Plan Office—(C377(11)) (Rs. 3064)

Municipal District of the Shire of Mortlake—Mortlake—for Municipal Building purposes—315 square metres, being Crown allotment 20, section 19, Township of Mortlake, Parish of Mortlake as shown on Certified Plan No. 107439 lodged in the Central Plan Office—(M210(2)) (Rs. 9069)

Municipal District of the Shire of Pyalong—High Camp—for Preservation of Species of Native Plants and Management of Wildlife—10.84 hectares, being Crown allotment 62E, Parish of Moranding, as shown on Certified Plan No. 107712 lodged in the Central Plan Office—(M139(2)) (Rs. 10639)

Municipal District of the Shire of Kerang—Benjeroop—for Conservation of an Area of Natural Interest—4.359 hectares, being Crown allotments 5A and 5B, section 1, Parish of Benjeroop as shown on Certified Plan No. 107468 lodged in the Central Plan Office—(B694(9)) (Rs. 5226)

Municipal District of the Shire of Towong—Bethanga—for Public Hall—2906 square metres, being Crown allotment 5A, section H, Township of Bethanga, Parish of Berringa as shown on Certified Plan No. 105764 lodged in the Central Plan Office—(B691(3)) (Rs. 12736)

Municipal District of the Shire of Swan Hill—Cocamba—for Water Supply purposes—2.496 hectares, being Crown allotment 37F, Parish of Cocamba as shown on Certified Plan No. 107647 lodged in the Central Plan Office—(C476(2)) (Rs. 13175)

Municipal District of the Shire of Walpeup—Bronzewing—for Conservation of an Area of

Natural Interest—77.61 hectares, being Crown allotment 22C, Parish of Pirro as shown on Certified Plan No. 107602 lodged in the Central Plan Office—(L5-1438)

Municipal District of the Shire of Rosedale—Callignee—for Management of Wildlife—46.07 hectares, being Crown allotments 6C, 6E and 6F, section B, Parish of Callignee as shown on Certified Plan No. 107707 lodged in the Central Plan Office—(C433(9)) (Rs. 13160)

Municipal District of the Shire of Ballan—Barrys Reef—for Water Supply purposes—1.734 hectares, being Crown allotment 1A, section 11A, Township of Barrys Reef, Parish of Blackwood as shown on Certified Plan No. 107470 lodged in the Central Plan Office—(B400(F4)) (Rs. 13159)

And the Honourable Joan Elizabeth Kirner, Her Majesty's Minister for Conservation, Forests and Lands for the State of Victoria, shall give the necessary directions herein accordingly.

TIM NEESON

Acting Clerk of the Executive Council

*Crown Land (Reserves) Act 1978*

*At the Executive Council Chamber, Melbourne, the twenty-first day of January 1986*

PRESENT:

His Excellency the Lieutenant-Governor  
of Victoria

Mr White  
Mr Jolly

Mrs Hogg

**CROWN LANDS TEMPORARILY RESERVED**

His Excellency the Lieutenant-Governor of the State of Victoria, in the Commonwealth of Australia, by and with the advice of the Executive Council of the said State, pursuant to the provisions of sections 4 and 7 of the *Crown Land (Reserves) Act 1978*, and being of the opinion that the Crown lands concerned are required for the purposes respectively mentioned, hereby temporarily reserves and also exempts from prospecting or from occupation for mining purposes under any miner's right the Crown lands hereinafter described, viz:

Municipal District of the City of Altona—Cut-Paw-Paw—for Health purposes—605 square metres, being Crown allotment A1, section 5, Parish of Cut-Paw-Paw, formerly being lot 132 on Plan of Subdivision No. 82921 lodged in the Office of Titles—(C345(19)) (Rs. 13027)

Municipal District of the City of Dandenong—Dandenong—for Health purposes—650 square metres, being Crown allotment 80A, Parish of Dandenong, formerly being lot 196 on Plan of Subdivision No. 86898 lodged in the Office of Titles—(D19(5)) (Rs. 12504)

Municipal District of the City of Sunshine—Derrimut—for Health purposes—587 square metres, being Crown allotment 1A, section 21, Parish of Derrimut, formerly being lot 79 on Plan of Subdivision No. 85045 lodged in the Office of Titles—(Parish 2516) (Rs. 12519)

Municipal District of the City of Preston—Keelbundora—for Community Welfare purposes—1 hectare, being Crown allotment 10U, Parish of Keelbundora, as shown on Certified Plan No. 106816 lodged in the Central Plan Office—(K25(5)) (Rs. 8630)

Municipal District of the Shire of Diamond Valley—Keelbundora—for Health purposes—547 square metres, being Crown allotment 19D, Parish of Keelbundora, formerly being lot 265 on Plan of Subdivision No. 84862 lodged in the Office of Titles—(K25(6)) (Rs. 13019)

Municipal District of the Shire of Lillydale—Mooroolbark—for Health purposes—922 square metres, being Crown allotment 9C, Parish of Mooroolbark, formerly being lot 749 on Plan of Subdivision No. 74324 lodged in the Office of Titles—(Rs. 12518)

Municipal District of the City of Oakleigh—Mulgrave—for Health purposes—1682 square metres being Crown allotment 41A, Parish of Mulgrave, formerly being lot 10 on Plan of Subdivision No. 17067 lodged in the Office of Titles—(Rs. 13024)

Municipal District of the City of Waverley—Mulgrave—for Health purposes—651 square metres, being Crown allotment 103A, Parish of Mulgrave, formerly being lot 26 on Plan of Subdivision No. 92161 lodged in the Office of Titles—(M263(5)) (Rs. 13033)

Municipal District of the City of Waverley—Mulgrave—for Health purposes—650 square metres, being Crown allotment 105A, Parish of Mulgrave, formerly being lot 100 on Plan of Subdivision No. 89769 lodged in the Office of Titles—(M263(5)) (Rs. 13026)

Municipal District of the Shire of Diamond Valley—Nillumbik—for Health purposes—859 square metres being Crown allotment 13A, Parish of Nillumbik, formerly being lot 8 on Plan of Subdivision No. 83989 lodged in the Office of Titles—(N69(10)) (Rs. 13029)

Municipal District of the City of Box Hill—Nunawading—for Health purposes—639 square metres, being Crown allotment 18D, Parish of Nunawading, formerly being lot 135 on Plan of Subdivision No. 32752 lodged in the Office of Titles—(N79(7)) (Rs. 13025)

Municipal District of the City of Nunawading—Nunawading—for Health purposes—644 square metres, being Crown allotment 113A, Parish of Nunawading, formerly being lot 244 on Plan of Subdivision No. 92929 lodged in the Office of Titles—(N79(7)) (Rs. 13020)

Municipal District of the City of Knox—Scoresby—for Health purposes—970 square metres, being Crown allotment 29A, Parish of Scoresby, formerly being lot 19 on Plan of Subdivision No. 50508 lodged in the Office of Titles—(S250(A6)) (Rs. 13030)

Municipal District of the City of South Melbourne—South Melbourne—for Ambulance Station and Ambulance Service Administrative Offices—4640 square metres, being Crown allotment 9A, section E, City of South Melbourne, Parish of Melbourne South, as shown on Certified Plan No. 107465 lodged in the Central Plan Office—(M333(32)) (Rs. 12570)

Municipal District of the Borough of Wonthaggi—Wonthaggi—for Health purposes—759 square metres, being Crown allotment 32E, Parish of Wonthaggi, formerly being lot 9 of Plan of Subdivision No. 5387 lodged in the Office of Titles—(Parish 3866) (Rs. 12468).

Municipal District of the Borough of Wonthaggi—Wonthaggi—for conservation of an Area of Natural Interest—2.192 hectares, more or less being Crown allotment 7, section 34, Township of Wonthaggi as shown on Certified Plan No. 101575 lodged in the Central Plan Office, together with Crown allotments 11 and 12, section 34, Township of Wonthaggi, as shown on Certified Plan No. 107250 lodged in the Central Plan Office—(W345(16)) (Rs. 13000)

And the Honourable Joan Elizabeth Kirner, Her Majesty's Minister for Conservation, Forests and Lands for the State of Victoria, shall give the necessary directions herein accordingly.

TIM NEESON

Acting Clerk of the Executive Council

#### LOCAL GOVERNMENT ACT 1958

At the Executive Council Chamber, Melbourne, the twenty-first day of January 1986

PRESENT:

His Excellency the Lieutenant-Governor  
of Victoria

Mr White		Mrs Hogg
Mr Jolly		

#### AUTHORIZATION OF WORKS OR UNDERTAKINGS FOR THE PURPOSES OF DIVISION 5 OF PART X OF THE LOCAL GOVERNMENT ACT 1958—SHIRE OF OTWAY

Whereas it is provided in section 277 (2) of the *Local Government Act 1958* that any works or undertakings not authorized by that Act (being works or undertakings that are for the special benefit of any particular portion of the municipal district) may, on the application of the council of the municipality, be authorized by Order of the Governor in Council published in the *Government*

*Gazette* and the council may make and levy a rate herein called a "separate rate" in respect of rateable property in such portion exclusively.

And whereas the Council of the Shire of Otway has made application to have the works or undertakings of electricity reticulation in portion of the municipal district of the Shire (being works or undertakings that are for the special benefit to that particular portion of the municipal district) to be authorized works or undertakings for the purposes of Division 5 of Part X of the *Local Government Act 1958*.

Now therefore, His Excellency the Governor of the State of Victoria, by and with the advice of the Executive Council thereof and in pursuance of the said section 277 (2) does by this Order authorize the works of electrical reticulation to Lots 1-9 on L.P. 130888, Parish of Krambruk in the municipal district of the Shire of Otway to be an authorized work or undertaking for the purpose of the said Division 5 of Part X of the *Local Government Act 1958*.

And the Honourable James Lionel Simmonds, Her Majesty's Minister for Local Government for the State of Victoria, shall give the necessary directions herein accordingly.

TIM NEESON  
Acting Clerk of the Executive Council

#### LOCAL GOVERNMENT ACT 1958

*At the Executive Council Chamber, Melbourne, the twenty-first day of January 1986*

PRESENT:

His Excellency the Lieutenant-Governor  
of Victoria

Mr White                      Mrs Hogg  
Mr Jolly                        |

#### CONSENT TO INCLUSION OF AN ADDITIONAL PROPERTY DURING THE CURRENCY OF A SEPARATE RATE— CITY OF CROYDON

Whereas by Order published in the *Government Gazette* on 26 April 1972 the Governor in Council pursuant to the provisions of section 287 of the *Local Government Act 1958*, confirmed a separate rate made by the Council of the City of Croydon for the purpose of providing off-street parking facilities for use in connection with the South Croydon Shopping Centre.

And whereas the Council of the City of Croydon is now of the opinion that a certain property, being the property described in the Schedule hereto, not being a property with respect to which the rate is levied would benefit from the works or undertakings carried out or to be carried out with the proceeds of the rate or with any monies borrowed on the security of the rate.

And whereas the Council has no sooner than one month after serving written notice on the owner and occupiers of the said property made and levied a rate not exceeding fifty nine point seven (59.7) cents in the dollar on the site value of the property.

Schedule

No. 124 Bayswater Road, South Croydon.

Now therefore, His Excellency the Governor of the State of Victoria, by and with the advice of the Executive Council thereof and in pursuance of the provisions of the provisions of section 290 of the *Local Government Act 1958*, hereby consents to the rate so made and levied forming part of the separate rate confirmed by notice published in the *Government Gazette* as aforesaid.

And the Honourable Peter Cornelis Spyker, Her Majesty's Acting Minister for Local Government for the State of Victoria, shall give the necessary directions herein accordingly.

TIM NEESON  
Acting Clerk of the Executive Council

#### LOCAL GOVERNMENT ACT 1958

*At the Executive Council Chamber, Melbourne, the twenty-first day of January 1986*

PRESENT:

His Excellency the Lieutenant-Governor  
of Victoria

Mr White                      Mrs Hogg  
Mr Jolly                        |

#### AUTHORIZATION OF WORKS OR UNDERTAKINGS FOR THE PURPOSES OF DIVISION 5 OF PART X OF THE LOCAL GOVERNMENT ACT 1958—SHIRE OF MANSFIELD

Whereas it is provided in section 277 (2) of the *Local Government Act 1958* that any works or undertakings not authorized by that Act (being works or undertakings that are for the special benefit of any particular portion of the municipal district) may, on the application of the council of the municipality, be authorized by Order of the Governor in Council published in the *Government Gazette* and the council may make and levy a rate herein called a "separate rate" in respect of rateable property in such portion exclusively.

And whereas the Council of the Shire of Mansfield has made application to have the works or undertakings of electricity reticulation in portion of the municipal district of the Shire (being works or undertakings that are for the special benefit to that particular portion of the municipal district) to be authorized works or undertakings for the purposes of Division 5 of Part X of the *Local Government Act 1958*.

Now therefore, His Excellency the Governor of the State of Victoria, by and with the advice of the Executive Council thereof and in pursuance of the said section 277 (2) does by this Order authorize the works of electrical reticulation to Lots 3-21, 24, 26-29 on LP 113857, Pollock Avenue, Bonnie Doon, Parish of Brankeet in the municipal district of the Shire of Mansfield to be an authorized work or undertaking for the purpose of the said Division 5 of Part X of the *Local Government Act 1958*.

And the Honourable James Lionel Simmonds, Her Majesty's Minister for Local Government for the State of Victoria, shall give the necessary directions herein accordingly.

TIM NEESON  
Acting Clerk of the Executive Council

#### LOCAL GOVERNMENT ACT 1958

*At the Executive Council Chamber, Melbourne, the twenty-first day of January 1986*

##### PRESENT:

His Excellency the Lieutenant-Governor  
of Victoria

Mr White		Mrs Hogg
Mr Jolly		

#### AUTHORIZATION OF WORKS OR UNDERTAKINGS FOR THE PURPOSES OF DIVISION 5 OF PART X OF THE LOCAL GOVERNMENT ACT 1958 SHIRE OF OTWAY

Whereas it is provided in section 277 (2) of the *Local Government Act 1958* that any works or undertakings not authorized by that Act (being works or undertakings that are for the special benefit of any particular portion of the municipal district) may, on the application of the council of the municipality, be authorized by Order of the Governor in Council published in the *Government Gazette* and the council may make and levy a rate herein called a "separate rate" in respect of rateable property in such portion exclusively.

And Whereas the Council of the Shire of Otway has made application to have the works or undertakings of electricity reticulation in portion of the municipal districts of the Shire (being works or undertakings that are for the special benefit to that particular portion of the municipal district) to be authorized works or undertakings for the purposes of Division 5 of Part X of the *Local Government Act 1958*.

Now therefore, His Excellency the Governor of the State of Victoria, by and with the advice of the Executive Council thereof and in pursuance of the said section 277 (2) does by this Order authorize the works of electrical reticulation to Lots 1 and 2 on L.P. 124713, Lots 3 and 4 on L.P. 125383 and Lots 5, 6, 7 and 8 on L.P. 119584, Campiglis Road, Kawarren in the municipal district of the Shire of

Otway to be an authorized work or undertaking for the purpose of the said Division 5 of Part X of the *Local Government Act 1958*.

And the Honourable James Lionel Simmonds, Her Majesty's Minister for Local Government for the State of Victoria, shall give the necessary directions herein accordingly.

TIM NEESON  
Acting Clerk of the Executive Council

#### LOCAL GOVERNMENT ACT 1958

*At the Executive Council Chamber, Melbourne, the twenty-first day of January 1986*

##### PRESENT:

His Excellency the Lieutenant-Governor  
of Victoria

Mr White		Mrs Hogg
Mr Jolly		

#### RECTIFICATION OF AN ERROR IN AN ORDER MADE FOR THE RESUBDIVISION OF THE MUNICIPAL DISTRICT OF THE SHIRE OF TAMBO

Whereas by Order published in the *Government Gazette* of 11 December 1985, the Lieutenant Governor-in-Council in pursuance of the provisions of Part II of the *Local Government Act 1958*, ordered, among other things, that on and from 1 April 1986 the municipal district of the Shire of Tambo be resubdivided and that the names of the four ridings be described as Buchan, Bumberrah, Coastal and Cunninghame.

Now therefore, His Excellency the Lieutenant-Governor of the State of Victoria by and with the advice of the Executive Council thereof and in pursuance of the provisions of section 28 (5) of the *Local Government Act 1958* hereby rectifies an error in the Order made aforesaid by substituting for the Riding named Buchan the name of Bruthen/Buchan.

And the Honourable James Lionel Simmonds, Her Majesty's Minister for Local Government for the State of Victoria, shall give the necessary directions herein accordingly.

TIM NEESON  
Acting Clerk of the Executive Council

*Audit Act 1958 No. 6203*  
TREASURY REGULATIONS 1981

*At the Executive Council Chamber, Melbourne, the  
twenty-first day of January 1986*

PRESENT:

His Excellency the Lieutenant-Governor  
of Victoria

Mr White		Mrs Hogg
Mr Jolly		

Whereas paragraph (a) of Regulation 71 (2) of the Treasury Regulations 1981 provides that Regulation 71 shall not apply in respect of the invitation of tenders to expenditure specifically authorized by the Governor in Council on the recommendation of the Treasurer.

And whereas the Treasurer has recommended that the expenditure detailed hereunder be specifically authorized by the Governor in Council.

Now therefore, pursuant to the powers conferred on him by the Treasury Regulations 1981 and all other powers enabling him in that behalf, His Excellency the Lieutenant-Governor of the State of Victoria, by and with the advice of the Executive Council thereof, does hereby authorize the expenditure of a maximum fee not exceeding Five thousand dollars (\$5000) by payment to J. R. Cumpston for the provision of consultancy services to provide actuarial advice on motor vehicle accident compensation.

And the Honourable Robert Allen Jolly, Her Majesty's Treasurer for the State of Victoria, shall give the necessary directions herein accordingly.

TIM NEESON  
Acting Clerk of the Executive Council

*Audit Act 1958 No. 6203*  
TREASURY REGULATIONS 1981

*At the Executive Council Chamber, Melbourne, the  
twenty-first day of January 1986*

PRESENT:

His Excellency the Lieutenant-Governor  
of Victoria

Mr White		Mrs Hogg
Mr Jolly		

Whereas paragraph (a) of Regulation 71 (2) of the Treasury Regulations 1981 provides that Regulation 71 shall not apply in respect of the invitation of tenders to expenditure specifically authorized by the Governor in Council on the recommendation of the Treasurer.

And whereas the Treasurer has recommended that the expenditure detailed hereunder be specifically authorized by the Governor in Council.

Now therefore, pursuant to the powers conferred on him by the Treasury Regulations 1981 and all other powers enabling him in that behalf, His Excellency the Lieutenant-Governor of the State of Victoria, by and with the advice of the Executive Council thereof, does hereby authorize the expenditure of an amount not exceeding Three thousand five hundred dollars (\$3500) by payment to David Crawford for the provision of consultancy services to prepare a report on financial matters relating to the South Melbourne Cricket Club.

And the Honourable Robert Allen Jolly, Her Majesty's Treasurer for the State of Victoria, shall give the necessary directions herein accordingly.

TIM NEESON  
Acting Clerk of the Executive Council

*Audit Act 1958 No. 6203*  
TREASURY REGULATIONS 1981

*At the Executive Council Chamber, Melbourne, the  
twenty-first day of January 1986*

PRESENT:

His Excellency the Lieutenant-Governor  
of Victoria

Mr White		Mrs Hogg
Mr Jolly		

Whereas paragraph (a) of Regulation 71 (2) of the Treasury Regulations 1981 provides that Regulation 71 shall not apply in respect of the invitation of tenders to expenditure specifically authorized by the Governor in Council on the recommendation of the Treasurer.

And whereas the Treasurer has recommended that the expenditure detailed hereunder be specifically authorized by the Governor in Council.

Now therefore, pursuant to the powers conferred on him by the Treasury Regulations 1981 and all other powers enabling him in that behalf, His Excellency the Lieutenant-Governor of the State of Victoria, by and with the advice of the Executive Council thereof, does hereby authorize the expenditure of an amount not exceeding Sixteen thousand dollars (\$16 000) by payment to K. F. Sharp and Associates for the provision of consultancy services with regard to the carrying out of a survey and case study of compulsory third party claimants.

And the Honourable Robert Allen Jolly, Her Majesty's Treasurer for the State of Victoria, shall give the necessary directions herein accordingly.

TIM NEESON  
Acting Clerk of the Executive Council

*Audit Act 1958 No. 6203*  
TREASURY REGULATIONS 1981

*At the Executive Council Chamber, Melbourne, the  
twenty-first day of January 1986*

PRESENT:

His Excellency the Lieutenant-Governor  
of Victoria

Mr White  
Mr Jolly

Mrs Hogg

Whereas paragraph (a) of Regulation 71 (2) of the Treasury Regulations 1981 provides that Regulation 71 shall not apply in respect of the invitation of tenders to expenditure specifically authorized by the Governor in Council on the recommendation of the Treasurer.

And whereas the Treasurer has recommended that the expenditure detailed hereunder be specifically authorized by the Governor in Council.

Now therefore, pursuant to the powers conferred on him by the Treasury Regulations 1981 and all other powers enabling him in that behalf, His Excellency the Lieutenant-Governor of the State of Victoria, by and with the advice of the Executive Council thereof, does hereby authorize the expenditure of an amount not exceeding Three thousand six hundred dollars (\$3600) by payment to O. R. Systems Pty. Ltd. to provide services with regard to an analysis of Compulsory Third Party Statistics.

And the Honourable Robert Allen Jolly, Her Majesty's Treasurer for the State of Victoria, shall give the necessary directions herein accordingly.

TIM NEESON  
Acting Clerk of the Executive Council

*Water Act 1958*  
RURAL WATER COMMISSION OF VICTORIA

*At the Executive Council Chamber, Melbourne, the  
twenty-first day of January, 1986*

PRESENT:

His Excellency the Lieutenant-Governor  
of Victoria

Mr White  
Mr Jolly

Mrs Hogg

GOULBURN-MURRAY IRRIGATION  
DISTRICT—PORTION EXCISED  
ROCHESTER IRRIGATION AREA—  
BOUNDARIES VARIED

Under the powers conferred by the *Water Act 1958* and all other powers enabling him in that behalf, His Excellency the Lieutenant-Governor of the State of Victoria, with the advice of the Executive Council of the said State, on the recommendation

of the Rural Water Commission of Victoria, doth hereby declare, order and direct that there shall be excised from the Goulburn-Murray Irrigation District the land shown by green colour on a plan approved by the Lieutenant-Governor in Council and deposited in the Office of the Rural Water Commission of Victoria at 590 Orrong Road, Armadale (Corr. No. 83/1315) and that the boundaries of the Rochester Irrigation Area shall be varied to excise therefrom such land which land shall be deemed to be excised from the said Irrigation District and Irrigation Area as on and from 31 January 1986.

And the Honourable Andrew McCutcheon, Her Majesty's Minister for Water Resources for the State of Victoria, shall give the necessary directions herein accordingly.

TIM NEESON  
Acting Clerk of the Executive Council

MOTOR CAR ACT 1958

*At the Executive Council Chamber, Melbourne, the  
twenty-first day of January 1986*

PRESENT:

His Excellency the Lieutenant-Governor  
of Victoria

Mr White  
Mr Jolly

Mrs Hogg

MOTOR CAR TRIALS OF SPEED WITHIN  
THE NEERIM PINE PLANTATION  
SHIRE OF BULN BULN

Whereas it is enacted by sub-sections (1) and (2) of section eighty-three A of the *Motor Car Act 1958* that, if a motor car is used on a highway for purposes of racing or of trial of speed, and if a race or trial of speed is organised or managed, the driver or the person in charge thereof and the person organising or managing the race or trial of speed, shall be liable to a penalty of not more than five hundred dollars for the first offence and one thousand dollars for the second offence, provided that the said sub-sections (1) and (2) shall not apply to a motor car used as aforesaid or to a race or trial of speed on any highway or portion thereof, specified by Order in Council published in the *Government Gazette* and on such days and during such hours as are specified in the Order.

And whereas the Ford Four Car Club has requested that such an Order be made to enable motor car trials of speed to be conducted by the said Club on the Neerim Pine Plantation, Shire of Buln Buln on 2 February 1986.

Now therefore, His Excellency the Lieutenant-Governor of the State of Victoria, by and with the advice of the Executive Council thereof, and in pursuance of the powers conferred by the *Motor Car Act 1958* and all other powers him thereunto

enabling, doth by this Order specify that the roads within the Neerim Pine Plantation, Shire of Buln Buln, as defined by the following boundaries:

*Northern and Eastern Boundary*

Roads west of Beards Road from its northern intersection with Memory Lane to its southern intersection with Memory Lane but not including Beards Lane.

*Western and South Boundary*

Memory Lane from its northern intersection with Beards Road to its southern intersection with Beards Road including Billson and Square Track—as highways which a race or speed trial may be held without being subject to the application of the said Act, under the control of the said Ford Four Car Club, on 2 February 1986, between the hours of 10.00 o'clock in the forenoon and 4.00 o'clock in the afternoon, provided that the Officer-in-Charge of Police in attendance is satisfied that the highway is in a satisfactory condition for racing purposes and that adequate arrangements have been made for the safety of the public and doth also specify that the Transport (Road Traffic) Regulations 1984 shall not apply to the location and on the date and between the times specified herein.

And the Honourable Thomas William Roper, Her Majesty's Minister for Transport for the State of Victoria, shall give the necessary directions herein accordingly.

TIM NEESON  
Acting Clerk of the Executive Council

DENTISTS ACT 1972

*At the Executive Council Chamber, Melbourne, the twenty-first day of January 1986*

PRESENT:

His Excellency the Lieutenant-Governor  
of Victoria

Mr White                      Mrs Hogg  
Mr Jolly                      |

DESIGNATION OF PAEDIATRIC  
DENTISTRY AS A SPECIAL BRANCH OF  
DENTISTRY

Whereas the Dental Board of Victoria has recommended that paediatric dentistry be a branch of dentistry in which dentists may be registered as specialist practitioners under Part IV A of the *Dentists Act 1972*:

And whereas section 28G of the *Dentists Act 1972* provides that the Governor in Council may by Order designate any branch of dentistry to be a special branch of dentistry for the purposes of Part IV A of the Act:

Now therefore His Excellency the Lieutenant-Governor of the State of Victoria in the Commonwealth of Australia by and with the advice

of the Executive Council of the said State do by this Order designate paediatric dentistry to be a special branch of dentistry for the purposes of Part IV A of the *Dentists Act 1972*.

And the Honourable David Ronald White, Her Majesty's Minister for Health for the State of Victoria shall give the necessary directions herein accordingly.

TIM NEESON  
Acting Clerk of the Executive Council

WEIGHTS AND MEASURES ACT 1958

*At the Executive Council Chamber, Melbourne, the twenty-first day of January 1986*

PRESENT:

His Excellency the Lieutenant-Governor  
of Victoria

Mr White                      Mrs Hogg  
Mr Jolly                      |

ORDER EXTENDING CERTAIN PROVISIONS  
OF THE WEIGHTS AND MEASURES ACT  
1958 TO THE MUNICIPAL DISTRICTS OF  
THE BOROUGH OF SEBASTOPOL AND THE  
SHIRES OF BARRABOOL, BUNGAREE,  
BUNINYONG AND ORBOST

Whereas by the *Weights and Measures Act 1958*, section 80, it is amongst other things enacted that the provisions of Division 3 of Part V. of the *Weights and Measures Act 1958* shall apply within any municipality or portion thereof to which the said provisions are extended by Order of the Lieutenant-Governor in Council published in the *Government Gazette*.

Now therefore His Excellency the Lieutenant Governor of the State of Victoria, in the Commonwealth of Australia, by and with the advice of the Executive Council of the said State, and in pursuance of the powers conferred by the *Weights and Measures Act 1958* and all other powers him thereunto enabling, doth by this Order extend the provisions of Division 3 of Part V. of the *Weights and Measures Act 1958* to the municipal districts of the Borough of Sebastopol and the Shires of Barrabool, Bungaree, Buninyong and Orbost.

And the Honorable Peter Cornelis Spyker, Her Majesty's Minister for Consumer Affairs for the State of Victoria, shall give the necessary directions herein accordingly.

TIM NEESON  
Acting Clerk of the Executive Council

BUILDING SOCIETIES ACT 1976—SECTION  
84

At the Executive Council Chamber, Melbourne, the  
twenty-first day of January 1986

PRESENT:

His Excellency the Lieutenant-Governor  
of Victoria

Mr White		Mrs Hogg
Mr Jolly		

Pursuant to the provisions of section 84 of the *Building Societies Act 1976*, His Excellency, the Lieutenant-Governor of the State of Victoria, by and with the advice of the Executive Council thereof, hereby appoints Roy Victor Morris, Robert Bernard Maybury and Joseph Kenneth Ballinger being persons having experience in the conduct and management of a society; and David Herbert Perkins, being a person who has extensive financial knowledge or experience, not being a person or employee of a person carrying on a business of making loans for housing purposes; and Phillip Coman, an officer of the Ministry of Consumer Affairs and nominated by the Director of Consumer Affairs, as members of the Building Societies' Advisory Committee for the period commencing on the date hereof and ending on 30 June, 1986, both dates inclusive.

And the Honourable Frank Noel Wilkes, Her Majesty's Minister of Housing for the State of Victoria, shall give the necessary direction herein accordingly.

TIM NEESON  
Acting Clerk of the Executive Council

WATER AND SEWERAGE AUTHORITIES  
(RESTRUCTURING) ACT 1983

At the Executive Council Chamber, Melbourne, the  
twenty-first day of January 1986

PRESENT:

His Excellency the Lieutenant-Governor  
of Victoria

Mr White		Mrs Hogg
Mr Jolly		

TAMBO WATER BOARD—EXTENT OF  
BRUTHEN WATERWORKS DISTRICT AND  
BRUTHEN URBAN DISTRICT INCREASED

Under the powers conferred by the *Water and Sewerage Authorities (Restructuring) Act 1983* and all other powers enabling him in that behalf, His Excellency the Lieutenant-Governor of the State of Victoria, by and with the advice of the Executive Council of the said State, doth hereby declare, order and direct that the extent of the Bruthen Waterworks District and Bruthen Urban District of the Tambo

Water Board be increased by adding thereto the lands shown in red and yellow border respectively on the plan approved by the Lieutenant-Governor in Council by and with this Order and deposited in the Office of the Department of Water Resources, Melbourne (Corr. No. 81/2158/53) and as on and from the date hereof the extent of such districts shall be and be deemed to be increased accordingly.

And the Honourable Andrew McCutcheon, Her Majesty's Minister for Water Resources for the State of Victoria, shall give the necessary directions herein accordingly.

TIM NEESON  
Acting Clerk of the Executive Council

HOSPITALS AND CHARITIES ACT 1958

At the Executive Council Chamber, Melbourne, the  
twenty-first day of January 1986

PRESENT:

His Excellency the Lieutenant-Governor  
of Victoria

Mr White		Mrs Hogg
Mr Jolly		

SECTION 5 AND 63A

Whereas the corporate name of the institution known as William Angliss Hospital, Upper Ferntree Gully has been changed to The William Angliss Knox and Sherbrooke Community Hospitals.

And whereas such change and approval has been notified in the *Government Gazette* No. 125 of 18 December 1985 on page 4698.

And whereas pursuant to sub-section (3) of section 5 of the *Hospitals and Charities Act 1958* the Governor in Council may by Order published in the *Government Gazette* declare that the name of any institution referred to in the Second Schedule of that Act has been changed and thereupon the said Schedule may be deemed to be amended accordingly.

And whereas pursuant to sub-section (1) of section 63A of the *Hospitals and Charities Act 1958* the Governor in Council may by Order published in the *Government Gazette* add the name of a subsidized incorporated institution to, or delete the name of institution from Table A in the Fifth Schedule.

Now therefore, His Excellency the Lieutenant-Governor of the State of Victoria, by and with the advice of the Executive Council of the State, doth hereby:

(1) declares that the name of the institution referred to in the Second Schedule of the said Act as William Angliss Hospital, Upper Ferntree Gully had been changed to The William Knox and Sherbrooke Community Hospital and the Second Schedule shall be deemed to be amended accordingly; and



(2) deletes the name of the institution referred to in the Fifth Schedule of the said Act as William Angliss Hospital, Upper Ferntree Gully and adds to such Schedule the name The William Angliss Knox and Sherbrooke Community Hospital.

And the Honourable David Ronald White, Her Majesty's Minister for Health for the State of Victoria, shall give the necessary directions herein accordingly.

TIM NEESON  
Acting Clerk of the Executive Council

#### HEALTH ACT 1958

*At the Executive Council Chamber, Melbourne, the tenth day of January 1986*

##### PRESENT:

His Excellency the Lieutenant-Governor  
of Victoria

Mr White		Mrs Hogg
Mr Jolly		

#### APPROVAL OF PLACES AT WHICH REGISTERED CONTRACEPTIVES MAY BE SOLD

Pursuant to the powers conferred by section 270L (3) of the *Health Act 1958*, and all the powers enabling him in that behalf, His Excellency the Lieutenant-Governor of the State of Victoria, by and with the advice of the Executive Council of the said State, and on the recommendation of the Health Department Victoria doth hereby approve of Banjo Theatre Restaurant, 55 Chetwynd Street, North Melbourne; Rising Sun Hotel, Cnr Swan and Burnley Streets, Richmond; Whitehorse Inn, 5 Burwood Road, Hawthorn; Mildura Grand Hotel, Langtree Avenue, Mildura; Mountain View Squash and Fitness Centre, 47-53 McMahons Road, Ferntree Gully; Complex Hotel, 265 Sunshine Road, Tottenham; Moreland Hotel, Cnr Moreland and Sydney Roads, Brunswick; Royal Derby Hotel, 446 Brunswick Street, Fitzroy; Sentimental Bloke Motor Hotel, 1 Thompsons Road, Bulleen; Carters Arms Hotel, 364 High Street, Northcote; Preston Hotel, 635 High Street, Preston; Meadow Inn Hotel, 1435 Sydney Road, Campbellfield; Templestowe Hotel, Parker Street, Lower Templestowe; London Hotel, 94 Beach Street, Melbourne; Heidelberg Hotel, Cnr Bell Street and Oriel Road, Heidelberg; Newborough Hotel, Monash Road, Newborough; Menzies Tavern, 500 Collins Street, Melbourne; Post Office Tavern Hotel, Elizabeth Street, Melbourne; Summerhill Hotel, 830 Plenty Road, Reservoir; Tropicana Club, 2 Dynon Road, South Kensington; Bush Inn Hotel, 505 Malvern Road, Toorak;

Beaconsfield Hotel, 341 Beaconsfield Parade, St. Kilda; Southern Cross Hotel, Cnr Ingliss and Station Streets, Port Melbourne; Olinda Hotel, 161 Main Street, Lilydale; Sandown Park Motor Hotel, Cnr Corrigan Road and Princes Highway, Noble Park; Dorset Gardens Hotel-Motel, 355 Dorset Road, Croydon; Astor Theatre, 1 Chapel Street, St Kilda; as places at which there may be sold by retail, registered contraceptives of the following class:

##### *Male Occlusive Devices*

Subject to the condition that such contraceptives are sold from contraceptive vending machines.

And the Honourable David Ronald White, Her Majesty's Minister for Health for the State of Victoria, shall give the necessary directions herein accordingly.

TIM NEESON  
Acting Clerk of the Executive Council

#### *Water and Sewerage Authorities (Restructuring) Act 1983*

##### *Sewerage Districts Act 1958*

#### ROCKBANK SEWERAGE DISTRICT PROCLAIMED

*At the Executive Council Chamber, Melbourne, the twenty-first day of January 1986*

##### PRESENT:

His Excellency the Lieutenant-Governor  
of Victoria

Mr White		Mrs Hogg
Mr Jolly		

#### MELTON SHIRE COUNCIL APPOINTED TO ADMINISTER ROCKBANK SEWERAGE WORKS

His Excellency the Lieutenant-Governor of Victoria, by and with the advice of the Executive Council doth hereby approve, in accordance with the provisions of the *Water and Sewerage Authorities (Restructuring) Act 1983* (incorporating part of the *Sewerage Districts Act 1958*), of the construction of reticulation sewers, pump stations and rising mains at Rockbank, as set out in the report and general plan accompanying the Application of the Melton Shire Council for the proclamation of a Sewerage District and the Appointment of the Council to construct, maintain and continue the said works in accordance with the provisions of the said Acts and doth hereby order and appoint as follows:

1. That the Melton Shire Council be appointed to construct, maintain and continue the proposed sewerage works which are estimated to cost \$823 100.

2. That the principal works proposed to be constructed shall consist of reticulation sewers, pumping stations and rising mains, and an outfall sewer.

3. That the lands shown bordered in red colour on the plan accompanying this Order and deposited in the office of the Department of Water Resources, Melbourne (Corr. No. 76/1349/27) are hereby proclaimed to be the Rockbank Sewerage District, such District being wholly within the Shire of Melton and being as set forth in the Application.

And the Honourable Andrew McCutcheon, Her Majesty's Minister for Water Resources for the State of Victoria, shall give the necessary directions herein accordingly.

TIM NEESON  
Acting Clerk of the Executive Council

#### WATER AND SEWERAGE AUTHORITIES (RESTRUCTURING) ACT 1983

*At the Executive Council Chamber, Melbourne, the  
twenty first day of January 1986*

PRESENT:

His Excellency the Lieutenant-Governor  
of Victoria

Mr White  
Mr Jolly

Mrs Hogg

#### TAMBO WATER BOARD—EXTENT OF LAKES ENTRANCE WATERWORKS DISTRICT INCREASED

Under the powers conferred by the *Water and Sewerage Authorities (Restructuring) Act 1983* and all others powers enabling him in that behalf, His Excellency the Lieutenant-Governor of the State of Victoria, by and with the advice of the Executive Council of the said State, doth hereby declare, order and direct that the extent of the Lakes Entrance Waterworks District of the Tambo Water Board be increased by adding thereto the lands shown in red on the plan approved by the Lieutenant-Governor in Council, by and with this Order and deposited in the Office of the Department of Water Resources, Melbourne (Corr. No. 85/730/23) and as on and from the date hereof the extent of such district shall be and be deemed to be increased accordingly.

And the Honourable Andrew McCutcheon, Her Majesty's Minister for Water Resources for the State of Victoria, shall give the necessary directions herein accordingly.

TIM NEESON  
Acting Clerk of the Executive Council

#### WATER AND SEWERAGE AUTHORITIES (RESTRUCTURING) ACT 1983

*At the Executive Council Chamber, Melbourne, the  
twenty-first day of January 1986*

PRESENT:

His Excellency the Lieutenant-Governor  
of Victoria

Mr White  
Mr Jolly

Mrs Hogg

#### HEATHCOTE WATER BOARD— AMENDMENT OF ORDER

Under the powers conferred by the *Water and Sewerage Authorities (Restructuring) Act 1983*, and all other powers enabling him in that behalf, His Excellency the Lieutenant-Governor of the State of Victoria by and with the advice of the Executive Council of the said State doth hereby amend as follows the Order in Council which constituted the Heathcote Water Board; such Order being made on 27 September 1983, and published in the *Victoria Government Gazette* of 28 September 1983:

Under section 21 the Members of the Board shall comprise:

Five Members elected by the voters of the Heathcote Electoral District and one Member elected by the voters of the Tooborac Electoral District.

And the Honourable Andrew McCutcheon, Her Majesty's Minister for Water Resources for the State of Victoria, shall give the necessary directions herein accordingly.

TIM NEESON  
Acting Clerk of the Executive Council

#### WATER AND SEWERAGE AUTHORITIES (RESTRUCTURING) ACT 1983

*At the Executive Council Chamber, Melbourne, the  
twenty-first day of January 1986*

PRESENT:

His Excellency the Lieutenant-Governor  
of Victoria

Mr White  
Mr Jolly

Mrs Hogg

#### DAYLESFORD WATER BOARD—EXTENT OF SEWERAGE DISTRICT INCREASED

Under the powers conferred by the *Water and Sewerage Authorities (Restructuring) Act* and all other powers enabling him in that behalf, His Excellency the Lieutenant-Governor of the State of Victoria, by and with the advice of the Executive

Council of the said State, doth hereby declare, order and direct that the extent of the Daylesford Sewerage District be increased by adding thereto the lands shown by blue border on the plan approved by the Lieutenant-Governor in Council by and with this Order and deposited in the office of the Department of Water Resources, Melbourne (Corr. No. P85/145A) and as on and from the date hereof the extent of such District shall be and be deemed to be increased accordingly.

And the Honourable Andrew McCutcheon, Her Majesty's Minister for Water Resources for the State of Victoria, shall give the necessary directions herein accordingly.

TIM NEESON  
Acting Clerk of the Executive Council

WATER AND SEWERAGE AUTHORITIES  
(RESTRUCTURING) ACT 1983  
WATER ACT 1958

*At the Executive Council Chamber, Melbourne, the  
the twenty-first day of January 1986*

PRESENT:

His Excellency the Lieutenant-Governor  
of Victoria

Mr White		Mrs Hogg
Mr Jolly		

SHEPPARTON WATER BOARD—SITES OF  
PIPELINES APPROVED

Under the powers conferred by the *Water and Sewerage Authorities (Restructuring) Act 1983*, the *Water Act 1958* and all other powers enabling him in that behalf, His Excellency the Lieutenant-Governor of the State of Victoria, by and with the advice of the Executive Council of the said State, doth hereby approve of the sites of pipelines as required by the Shepparton Water Board and shown by yellow colour on the plans marked "A", "B" and "C" approved by the Lieutenant-Governor in Council, by and with this Order and deposited in the office of the Department of Water Resources, Melbourne (Corr. No. 85/547/26).

And the Honourable Andrew McCutcheon, Her Majesty's Minister for Water Resources for the State of Victoria, shall give the necessary directions herein accordingly.

TIM NEESON  
Acting Clerk of the Executive Council.

WATER AND SEWERAGE AUTHORITIES  
(RESTRUCTURING) ACT 1983  
WATER ACT 1958

*At the Executive Council Chamber, Melbourne, the  
twenty-first day of January 1986*

PRESENT:

His Excellency the Lieutenant-Governor  
of Victoria

Mr White		Mrs Hogg
Mr Jolly		

SEYMOUR WATER BOARD  
SITE OF WORKS APPROVED

Under the powers conferred by the *Water and Sewerage Authorities (Restructuring) Act 1983*, the *Water Act 1958* and all other powers enabling him in that behalf, His Excellency the Lieutenant-Governor of the State of Victoria, by and with the advice of the Executive Council of the said State, doth hereby approve of the site of a works as required by the Seymour Water Board and shown by red colour on the plan approved by the Lieutenant-Governor in Council, by and with this Order and deposited in the office of the Department of Water Resources, Melbourne (Corr. No. L85/438/1).

And the Honourable Andrew McCutcheon, Her Majesty's Minister for Water Resources for the State of Victoria, shall give the necessary directions herein accordingly.

TIM NEESON  
Acting Clerk of the Executive Council

WATER AND SEWERAGE AUTHORITIES  
(RESTRUCTURING) ACT 1983  
WATER ACT 1958

*At the Executive Council Chamber, Melbourne, the  
twenty-first day of January 1986*

PRESENT:

His Excellency the Lieutenant-Governor  
of Victoria

Mr White		Mrs Hogg
Mr Jolly		

SEYMOUR WATER BOARD—SITE OF  
PIPELINE APPROVED

Under the powers conferred by the *Water and Sewerage Authorities (Restructuring) Act 1983*, the *Water Act 1958* and all other powers enabling him in that behalf His Excellency the Lieutenant-Governor of the State of Victoria, by and with the advice of the Executive Council of the said State, doth hereby approve of the site of a pipeline as required by the Seymour Water Board and shown by red colour on the plan approved by the Lieutenant-Governor in Council, by and with this

Order and deposited in the office of the Department of Water Resources, Melbourne (Corr. No. L85/438/2).

And the Honourable Andrew McCutcheon, Her Majesty's Minister for Water Resources for the State of Victoria, shall give the necessary directions herein accordingly.

TIM NEESON  
Acting Clerk of the Executive Council

## TENDERS

### PUBLIC WORKS DEPARTMENT

Tenders are invited for the purposes indicated hereunder and will be received at 2 Treasury Place, Melbourne, 3002, until TWO p.m. on the dates shown.

Tenders must be addressed to the Minister for Public Works with the envelope endorsed "Tender for "

Tenders forwarded either by mail, telegram or telex, which arrive after the closing time, will be accepted provided that the official Telecom or Australia Post time and date stamping indicates dispatch prior to the closing time. (TIME AND DATE STAMPING MUST BE REQUESTED AT SOME POST OFFICES.)

(TELEX No. AA152039)

Hand-delivered tenders must be placed in the Department's tender box in foyer, Ground Floor, 2 Treasury Place, Melbourne.

Tender documents are available from the Contracts Office, Room 29, Ground Floor, 2 Treasury Place, Melbourne and, where indicated, at offices of Inspector of Works.

★Tenders identified with a star (★) will only be considered from contractors qualified for repairs and painting works. Any tenderers wishing to qualify may obtain the application form from the Contracts Office.

### Wednesday, 5 February 1986

#### Building, Electrical and Mechanical Services

GLENROY—Fire re-instatement, Mechanical Services, Technical School.

JANEFIELD—Connection of sewerage system to M.M.B.W. sewer, Training Centre.

LANGI KAL KAL—Fire service upgrade, Youth Training Centre (W.O. Ararat and Ballarat).

#### Miscellaneous

MELBOURNE—Supply telephone line test units, Police Radio Electronics Division, 376 Russell Street, Police Complex.

MOORABBIN—Supply of survey equipment, College of T.A.F.E.

MOORABBIN—Supply of A.V. and T.V. equipment, T992, College of T.A.F.E.

MOORABBIN—Supply of A.V. and T.V. equipment, T991, College of T.A.F.E.

PLENTY—Supply and install shelving for the main kitchen, Mental Hospital.

### Wednesday, 12 February 1986

#### Building, Electrical and Mechanical Services

BENDIGO—Heating and cooling of six residential units, Sandhurst Centre (W.O. Bendigo).

BRAYBROOK—Electrical upgrade, High School.

CALIFORNIA GULLY (Re-advertised)—Interior renovations and alterations, Primary School (W.O. Bendigo).

★FLEMINGTON—Repairs and painting, High School.

HEIDELBERG WEST—Provision of fire protection, Primary School.

MAROONDAH—Provision of static storage tank and associated services, High School.

MELBOURNE—Fitting out works to 2nd Floor, 600 Collins Street—Department of Property and Services.

MELBOURNE—Supply and installation of card access system, computer centre, 3 MacArthur Street—Department of Property and Services.

MELBOURNE—Provide fire protection to staircases, 376 Russell Street, Police Complex.

NICHOLS POINT—Maintenance of red brick building, Primary School (W.O. Mildura).

★PLENTY—Internal repairs and painting, Mental Hospital.

★SHEPPARTON—External and part internal repairs and painting, Primary School (W.O. Benalla, Shepparton and Wangaratta).

TRARALGON—Replace roof, High School (W.O. Traralgon).

WARRAGUL—Renovations, State Public Offices (W.O. Warragul).

#### Miscellaneous

PORT MELBOURNE—Purchase of one (1) only trailer-mounted elevating work platform, P.W.D. Storeyard, 69 Salmon Street.

### Wednesday, 19 February 1986

#### Building, Electrical and Mechanical Services

BRAYBROOK—Repairs, renovations and alterations, High School.

BROADMEADOWS WEST—Concreting works, Technical School.

GEELONG—Rectification work of west wall, H Block, Gordon College of T.A.F.E. (W.O. Geelong).

PRAHRAN—Office fit-out, Office of Corrections, 68 Greville Street.

★PRINCES HILL (Re-advertised)—External maintenance, High School.

SOUTH MELBOURNE—Landscaping, Coronial Services Centre—Law Department.

SOUTH MELBOURNE—Fire detector, Coronial Services Centre—Law Department.

RONALD W. WALSH  
Minister for Public Works

Public Works Department  
Melbourne, 28 January 1986

**PRIVATE  
ADVERTISEMENTS**

Readvertised  
**CITY OF BROADMEADOWS**  
Discontinuance of Road

Whereas pursuant to section 528 (2) of the *Local Government Act 1958*, the Council of the City of Broadmeadows is of the opinion that the road delineated and marked by hatching and cross hatching on the plan set out hereunder (not being a road set out on Crown Land), viz: the land referred to as a drainage easement on lodged plan 5814 of Crown Portion 151 Parish of Jika Jika, is no longer reasonably required as a road for public use and having not less than one month previous to this resolution published a Notice in a newspaper generally circulating in the Municipality and posting to the registered owner of the road and to the owners and occupiers of the lands abutting the road and having consulted with the public authorities pursuant to section 528 (a) (iii) of the Act, of such intention resolved at its meeting of 26 August 1985 that the said road be discontinued and upon publication of such resolution in the *Government Gazette* the discontinued road shall vest in the City of Broadmeadows by sub-section (2) (e) of the section 528 of the Act:

- (1) the land marked by hatching, sold by private treaty;
- (2) the land marked by cross hatching, retained by the City of Broadmeadows.

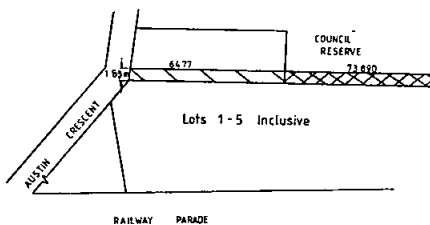

1510

B. D. MCGREGOR, Town Clerk

Re-Advertised  
*Local Government Act 1958*  
**ROAD DISCONTINUANCE—CITY OF  
BROADMEADOWS**

Whereas pursuant to section 528 (2) of the *Local Government Act* the Council of the City of Broadmeadows is of the opinion that the road delineated and marked by hatching on the plan hereunder (not being a road set out on Crown land) is no longer reasonably required as a road for public use and having not less than one month previous to this resolution published a Notice in a newspaper generally circulating in the municipality and posting to the registered owner of the road and to the owners and occupiers of the lands abutting the road and having consulted with the public authorities pursuant to section 528 (2) (a) (iii) of the Act, of such intention resolved at its meeting of 29 July 1985 that the said road be discontinued and upon publication of the resolution in the *Government Gazette* the discontinued road shall vest in the Council subject to the rights reserved in the Board of Works and the City of Broadmeadows by sub-section (2) (e) of section 528 and retained until sold by private treaty.

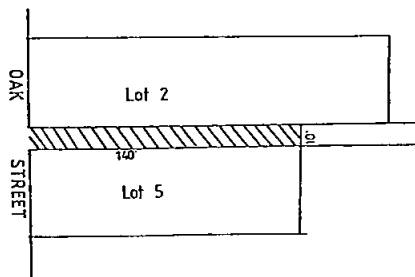

1487

B. D. MCGREGOR, Town Clerk

Form 2.1

*Town and Country Planning Act 1961*

Notice that a Planning Scheme has been Prepared and is Available for Inspection

**CITY OF KNOX PLANNING SCHEME, 1965**  
Amendment No. 283, 1985

Notice is hereby given that the Council of the City of Knox in pursuance of its powers under the *Town and Country Planning Act, 1961*, has prepared a Planning Scheme for the purpose of—

- (i) rezoning land at the south-east corner of Mountain Highway/Miller Road, The Basin, being Lots 1 and 2 on L.P. 10642, from Residential "A" to commercial Drive-In;
- (ii) restricting the use/development of the subject allotments to Service Station and associated garden and car parking areas.

The rezoning will enable the existing Service Station to be re-built and eliminate the non-conforming status of the subject land.

A copy of the Scheme has been deposited at the Office of the City of Knox, Civic Centre, 511 Burwood Highway, Knoxfield, and at the Office of the Ministry for Planning and Environment, 5th Floor, 235 Queen Street, Melbourne, and will be available for inspection during office hours by any person free of charge.

Any persons affected by the Planning Scheme are required to set forth in writing any submissions they may wish to make with respect to the Scheme, addressed to the Town Clerk, City of Knox, Civic Centre, 511 Burwood Highway, Knoxfield, by 3 March 1986 and to state whether they wish to be heard in respect of their submissions.

Dated 24 January 1986

1472 T. J. NEVILLE, Chief Executive

Form 2.1

Town and Country Planning Act 1961

Notice that a Planning Scheme has been Prepared and is Available for Inspection

CITY OF KNOX PLANNING SCHEME, 1965

Amendment No. 285, 1985

Notice is hereby given that the Council of the City of Knox in pursuance of its powers under the *Town and Country Planning Act 1961*, has prepared a Planning Scheme for the purpose of rezoning part of the land on the south side of Ferntree Gully Road (Caribbean Gardens), Scoresby, approximately 440 metres west of Koornang Road, being part of Crown Allotment 3, Parish of Narree Worrان, from Special Uses D (Private Recreation) to Special Uses H (Market).

The rezoning will allow expansion of the Market operation and pedestrian access, public facilities and traffic management on site to be upgraded.

A copy of the Scheme has been deposited at the Office of the City of Knox, Civic Centre, 511 Burwood Highway, Knoxfield and at the Office of the Ministry for Planning and Environment, 5th Floor, 235 Queen Street, Melbourne and will be available for inspection during office hours by any person free of charge.

Any persons affected by the Planning Scheme are required to set forth in writing any submissions they may wish to make with respect to the Scheme, addressed to the Town Clerk, City of Knox, Civic Centre, 511 Burwood Highway, Knoxfield, by 3 March 1986 and to state whether they wish to be heard in respect of their submissions.

Dated 24 January 1986

1474 T. J. NEVILLE, Chief Executive

CITY OF NUNAWADING

Change of Street Name

In accordance with the provisions of section 535 of the *Local Government Act 1958*, the Council of the City of Nunawading has resolved that the portion of Weeden Drive, Vermont South containing property numbers 161-177 and 146-170 as indicated by hatchure on the plan hereunder be renamed Mont Court.

Old Name—(Part) Weeden Drive

New Name—Mont Court

Suburb—Vermont South

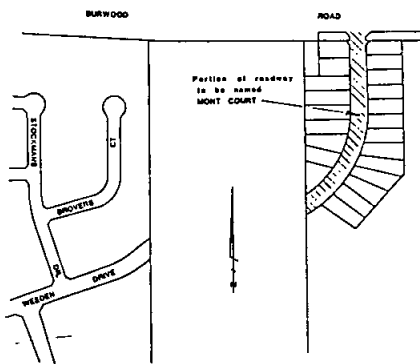

1475 L. FELL, Chief Executive

Form 2.1

Town and Country Planning Act 1961

Notice that a Planning Scheme has been Prepared and is Available for Inspection

CITY OF KNOX PLANNING SCHEME, 1965

Amendment No. 286, 1985

Notice is hereby given that the Council of the City of Knox in pursuance of its powers under the *Town and Country Planning Act 1961*, has prepared a Planning Scheme for the purpose of rezoning land at the south-west corner of Boronia Road and Mountain Highway, Wantirna, being part of Crown Allotment 22, Parish of Scoresby, from Rural "A" and Special Uses C (Drive-In Theatre) to Special Uses D (Private Recreation).

A copy of the Scheme has been deposited at the Office of the City of Knox, Civic Centre, 511 Burwood Highway, Knoxfield and at the Office of the Ministry for Planning and Environment, 5th Floor, 235 Queen Street, Melbourne and will be available for inspection during office hours by any person free of charge.

Any persons affected by the Planning Scheme are required to set forth in writing any submissions they may wish to make with respect to the Scheme,

addressed to the Town Clerk, City of Knox, Civic Centre, 511 Burwood Highway, Knoxfield, by 3 March 1986 and to state whether they wish to be heard in respect of their submissions.

Dated 24 January 1986

1473 T. J. NEVILLE, Chief Executive

**BOROUGH OF WONTHAGGI**  
Water and Sewerage Authorities (Restructuring)  
Act

Proclamation of a Sewerage District

Notice is hereby given that the Council of the Borough of Wonthaggi has made application to the Minister for Water Resources for the proclamation of a Sewerage District at the Township of Cape Paterson and for the appointment of the Wonthaggi-Inverloch Water Board for the construction, maintenance and continuance of sewerage works within that District under the provisions of the Water and Sewerage Authorities (Restructuring) Act.

A general plan and description of the proposed works have been submitted with the application and copies of same may be seen at the Municipal Offices, Town Hall, McBride Avenue, Wonthaggi during office hours (9.00 a.m.—4.30 p.m.).

Dated at Wonthaggi, 18 December 1985

A. A. N. DEED, Town Clerk

Note: The Act requires that this notice be published weekly for three weeks in a newspaper circulating locally and the *Government Gazette*, and provides that within one month of the third notice in the *Government Gazette* any persons having an interest therein who is likely to be injuriously affected by the proposed sewerage works may forward to the Minister for Water Resources, 590 Orrong Road, Armadale 3143 a petition seeking refusal or amendment to the application. In this case the period for objections will expire on 5 March 1986. 1242

**SCHEDULE 1**  
Form 2.1

*Town and Country Planning Act 1961*  
**CRANBOURNE PLANNING SCHEME 1960**  
Notice that a Planning Scheme has been prepared  
and is Available for Inspection

*Amendment No. 59—1985*

Notice is hereby given that the Shire of Cranbourne in pursuance of its powers under the *Town and Country Planning Act 1961*, has prepared a Scheme:

To amend the Principal Scheme by rezoning land fronting Narre Warren and Thompsons Roads, Cranbourne from Rural and Reserved Living Zone to Road Widening Reservation in accordance with R.C.A. Plan No. 130798A, (Sheet 2).

A copy of the Scheme has been deposited at the Shire Offices, Cranbourne, and at the Office of the Ministry of Planning and Environment, The Olderfleet Buildings, 477 Collins Street, Melbourne, and will be open for inspection during office hours by any person free of charge.

Any persons affected by the Scheme are required to set forth in writing any submissions they may wish to make with respect to the Scheme addressed to the Shire Secretary, Shire of Cranbourne, Shire Offices, Cranbourne, by 29 April 1986 and to state whether you wish to be heard in respect of your submissions.

1488

A. J. HOBAN, Town Planner

**SCHEDULE 1**  
Form 2.1

*Town and Country Planning Act 1961*  
**CRANBOURNE PLANNING SCHEME 1960**  
Notice that a Planning Scheme has been prepared  
and is Available for Inspection

*Amendment No. 57—1985*

Notice is hereby given that the Shire of Cranbourne in pursuance of its powers under the *Town and Country Planning Act 1961*, has prepared a Scheme:

To amend the Principal Scheme by rezoning land being Lots 1-6 (inclusive), LP 7319, the northern half of Lot 17, LP 7319 and the north eastern corner CA 12A, Parish of Lyndhurst, Stevensons and Cranbourne-Frankston Roads, Cranbourne from Rural and Industrial B to Reserved Living and by amending the Ordinance to provide for low density residential development in that area.

A copy of the Scheme has been deposited at the Shire Offices, Cranbourne, and at the Office of the Ministry of Planning and Environment, The Olderfleet Buildings, 477 Collins Street, Melbourne, and will be open for inspection during office hours by any person free of charge.

Any persons affected by the Scheme are required to set forth in writing any submissions that may wish to make with respect to the Scheme addressed to the Shire Secretary, Shire of Cranbourne, Shire Offices, Cranbourne, by 1 March 1986 and to state whether you wish to be heard in respect of your submissions.

1489

A. J. HOBAN, Town Planner

**SHIRE OF COBRAM**

Notice of Intention to Take Land Compulsorily

Whereas the Council of the Shire of Cobram has deemed it expedient to exercise its powers of taking land compulsorily in accordance with the provisions of section 513 of the *Local Government Act 1958* (as amended) notice is hereby given as follows:

1. The Council intends to acquire all that land delineated and cross hatched on the plan at the foot hereof being—

Part of Lot 1 on Plan of Subdivision No. 91751 and being part of the land comprised in Certificate of Title Volume 8922 Folio 331, having a frontage of 20.1 metres to Mookarii Street by a depth of 8.7 metres and

Part of Lot 1 on Plan of Subdivision No. 20572 and being part of the land comprised in Certificate of Title Volume 7534 Folio 012, having a frontage of 18.7 metres to Mookarii Street by a depth of 8.7 metres for the purposes of off-street parking.

2. The Council has caused to be prepared maps and other papers describing the proposed work or undertaking and the description of the land proposed to be taken together with the names of the owners or reputed owners, lessees or reputed lessees, mortgagees and occupiers of such lands so far as those persons are known to or can be ascertained by the Council.

3. Such maps and other papers have been approved by Council and are deposited at the Shire Office, Station Street, Cobram where they are and will remain open for inspection by all persons interested during office hours for a period of forty (40) clear days after publication of this notice in the *Government Gazette*.

4. All persons affected by the proposed taking of the lands are hereby called upon to set forth in writing addressed to the Council or the Shire Secretary of the Shire of Cobram, P.O. Box 182, Cobram, 3644, within forty (40) clear days from the publication of this notice in the *Government Gazette* all objections which they may have to the taking of the said land.

SHIRE OF COBRAM

Notice of Intention to Take Land Compulsorily

Whereas the Council of the Shire of Cobram has deemed it expedient to exercise its powers of taking land compulsorily in accordance with the provisions of section 513 of the *Local Government Act 1958* (as amended) notice is hereby given as follows:

1. The Council intends to acquire all that land delineated and cross hatched on the plan at the foot hereof being—

Part of Lot 1 on Plan of Subdivision No. 92719 and being part of the land comprised in Certificate of Title Volume 8914 Folio 301, having a frontage of 17.6 metres to Mookarii Street by a depth of 8.7 metres more or less for the purposes of off-street parking.

2. The Council has caused to be prepared maps and other papers describing the proposed work or undertaking and the description of the land proposed to be taken together with the names of the owners or reputed owners, lessees or reputed lessees, mortgagees and occupiers of such lands so far as those persons are known to or can be ascertained by the Council.

3. Such maps and other papers have been approved by Council and are deposited at the Shire Office, Station Street, Cobram where they are and will remain open for inspection by all persons interested during office hours for a period of forty (40) clear days after publication of this notice in the *Government Gazette*.

4. All persons affected by the proposed taking of the lands are hereby called upon to set forth in writing addressed to the Council or the Shire Secretary of the Shire of Cobram, P.O. Box 182, Cobram, 3644, within forty (40) clear days from the publication of this notice in the *Government Gazette* all objections which they may have to the taking of the said land.

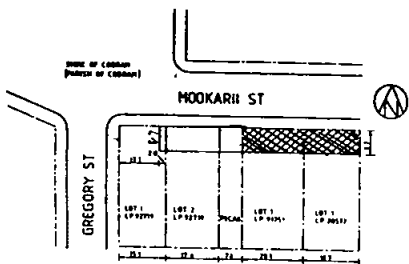

The measurements are in metres

By order of the Council.  
W. LENYSZYN  
Shire Secretary

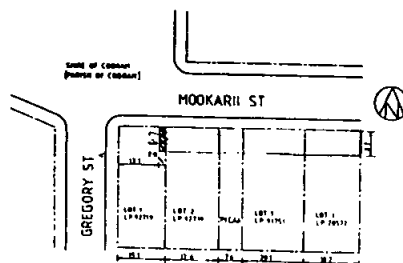

The measurements are in metres

By order of the Council.  
W. LENYSZYN  
Shire Secretary



**SHIRE OF COBRAM**

Notice of Intention to take Land Compulsorily

Whereas the Council of the Shire of Cobram has deemed it expedient to exercise its powers of taking land compulsorily in accordance with the provisions of Section 513 of the *Local Government Act 1958* (as amended) notice is hereby given as follows:

1. The Council intends to acquire all that land delineated and cross hatched on the plan at the foot hereof being—

Part of Lot 2 on Plan of Subdivision No. 92719 and being part of the land comprised in Certificate of Title Volume 8914 Folio 302 having a frontage of 17.6 metres to Mookarii Street by a depth of 8.7 metres more or less for the purposes of off-street parking.

2. The Council has caused to be prepared maps and other papers describing the proposed work or undertaking and the description of the land proposed to be taken together with the names of the owners or reputed owners, lessees or reputed lessees, mortgagees and occupiers of such lands so far as those persons are known to or can be ascertained by the Council.

3. Such maps and other papers have been approved by Council and are deposited at the Shire Office, Station Street, Cobram where they are and will remain open for inspection by all persons interested during office hours for a period of forty (40) clear days after publication of this notice in the *Government Gazette*.

4. All persons affected by the proposed taking of the lands are hereby called upon to set forth in writing addressed to the Council or the Shire Secretary of the Shire of Cobram, P.O. Box 182, Cobram, 3644, within forty (40) clear days from the publication of this notice in the *Government Gazette* all objections which they may have to the taking of the said land.

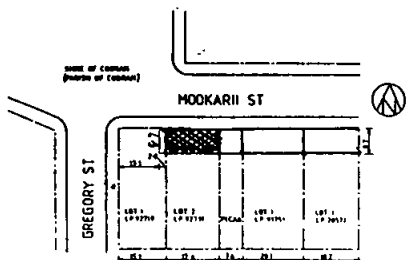

The measurements are in metres

By order of the Council.

W. LENYSZYN  
Shire Secretary

1534

**SHIRE OF ORBOST**

Declaration of Road as Public Highway

Pursuant to the provisions of section 522 of the *Local Government Act 1958* the Council of the Shire of Orbost hereby directs that the land in the Parish of Nowa Nowa South, County of Tambo being part of Crown Allotment 4, Section A, Vol. 9653, Fol. 648, indicated by hatching on the diagram hereunder, which has been purchased taken or acquired by it, shall be a public highway on and from the date of publication of the order in the *Government Gazette*.

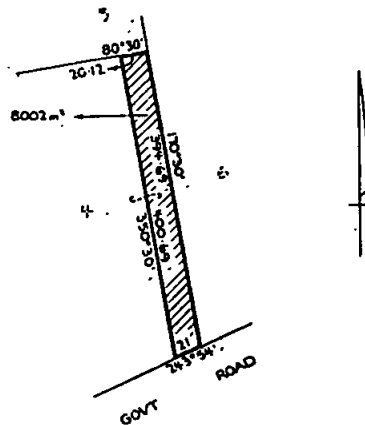

MEASUREMENTS ARE IN METRES

The Common Seal of the President, Councillors and Ratepayers of the Shire of Orbost was hereto affixed 17 January 1986 in the presence of:

D. L. BAIRD, Shire President  
W. WITHERS, Councillor

1511

J. R. COURT, Shire Secretary

*Town and Country Planning Act 1961*

**SHIRE OF ROMSEY INTERIM DEVELOPMENT ORDER 1977**

Notice that a Interim Development Order Amendment has been prepared and is Available for Inspection

*Amendment No. 13*

Notice is hereby given that the Shire of Romsey in pursuance of its powers under the *Town and Country Planning Act 1961* has prepared an order for rezoning that Part of W. J. T. Clarke Special Survey, Parish of Kerrie, north of Websters Road, Clarkefield, from General Farming Zone to Reserved for Public Purposes Zone (Riddells Creek Water Board—Waste Water Treatment Site).

A copy of the amendment has been deposited at the Shire Offices, Romsey and at the office of the Ministry for Planning and Environment, The Olderfleet Buildings, 477 Collins Street, Melbourne, and will be open for inspection during office hours by any person free of charge.

Any persons affected by the amendment are required to set forth in writing any submission they may wish to make with respect of the amendment addressed to the Shire Secretary, Shire of Romsey, Main Street, Romsey, 3434, by 29 February 1986, and state whether you wish to be heard in respect of your submission.

23 January 1986.

1490 B. F. CARNE, Shire Secretary

#### SHIRE OF SHERBROOKE

##### Appointment of Poundkeeper

In accordance with the provisions of the *Pounds Act 1958* (as amended) the Council has appointed Mr Peter John Monopoli, 1 Brae Road, Lysterfield, to act as Poundkeeper for the Shire of Sherbrooke in lieu of the previous appointment of Mr John Baines.

1476 K. E. MATSON  
General Manager/Shire Secretary

#### STAWELL WATER BOARD

##### Notice of Commencement of Construction of Sewerage Works

Pursuant to section 119 (2) of the *Sewerage Districts Act 1958* notice is hereby given of the intention to construct sewers for properties situated in the following areas at least 30 days after the date of this notice.

Newton Street—Lot 3 of LP 75872 of Part Crown Allotment 7, section 135 Parish of Stawell and more particularly as shown on plans which are open for inspection at this office between the hours of 8.30 a.m. and 5.15 p.m. on Monday to Friday inclusive.

1477 N. R. ILLIG, Secretary

#### COLAC DISTRICT WATER BOARD

Pursuant to section 119 (2) of the *Sewerage Districts Act 1958*, notice is hereby given of the intention to construct sewers in—

Armstrong Street,  
Elsinore Street and  
Tulloh Street

Colac, more particularly as shown on a plan which is open for inspection at the Board's Office between the hours of 9.00 a.m. and 5.00 p.m. Monday to Friday inclusive.

1478 J. T. WILKINSON, Manager/Secretary

#### COLAC DISTRICT WATER BOARD

##### General Notice

The abovementioned Water Board having made provision for carrying off the sewage from each and every property which or any part of which is within the sewerage area hereinafter described doth hereby declare that on and after the first day of February 1986 each and every property which or any part of which is within the said sewerage area shall be deemed to be sewerer properties within the meaning of the *Sewerage Districts Act 1958*.

The sewerer area hereinbefore referred to is:

*Sewerage Area No. 76*

Parcel Index 153 and 501, Sheet 4, Parish of Elliminyt, Irrewillipe Road.

1479 J. T. WILKINSON, Manager/Secretary

#### SUNBURY WATER BOARD

Notice is hereby given that the above Authority intends to construct sewers and related works in the area generally known as the Kingsley Park Estate to serve properties situated in the whole or parts of the areas hereinafter described in the Sunbury Sewerage District.

Maps and plans showing the works to be constructed are open for inspection at the Board's office, between the hours of 9.00 a.m. and 5.00 p.m. Monday to Friday.

The area referred to above comprises the area generally bounded by Mitchells Lane to the North, and Carlson Street and Vineyard Road to the East.

1491 JOHN M. KELLY, Secretary

#### GEELONG AND DISTRICT WATER BOARD

Pursuant to section 60 of the *Geelong Waterworks and Sewerage Act 1958* (No. 6263) the Board has prepared plans to indicate the particulars of sewers and underground works, the construction of which the Board intends to begin at a date not less than one month after publication of the notices in or adjacent to the following locality within the Drainage Area.

Malvern Grove, Manifold Heights—City of Geelong West.

Gloucester Street, Rau Court, Pioneer Road, Norfolk Avenue, Grovedale—City of South Barwon.

Princes Highway, Waurn Ponds—City of South Barwon.

Notice is hereby given that the plans indicated are open for public inspection at the Board's Offices, 61–67 Ryrie Street, Geelong between the hours of 8.10 a.m. and 5.00 p.m. from Monday to Friday (public holidays excepted) by the owners or occupiers of land or premises within the Drainage Area.

1512 R. A. JORDAN, Secretary

Notice is hereby given that the Partnership heretofore subsisting between Robert John Peters and Simone Fleur Peters carrying on business as Manufacturers of hi-fidelity loud speakers and furniture at 11 Fury Court, Clayton South in the State of Victoria, under the style or firm of Peterson Speakers (Aust.) has been dissolved as from 21 January 1986, so far as concerns the said Simone Fleur Peters who retires from the said firm, and that the business under the style or form of Peterson Speakers (Aust.) shall be carried on under the sole proprietorship of the said Robert John Peters.

Dated 21 January 1986

1493 **ROBERT JOHN PETERS**  
**SIMONE FLEUR PETERS**

Companies Form 142

Paragraphs 577 (1) (g) and (ga), Sub-regulation 137 (1)

Companies (Victoria) Code

Notice of Intention to Declare a Dividend  
**BERRELLI FREIGHTERS (AUSTRALIA) PTY.**  
**LTD.**

A first and final dividend is to be declared on 14 March 1986, in respect of the company.

Creditors whose debts or claims have not already been admitted are required on or before 28 February 1986, formally to prove their debts or claims. In default, they will be excluded from the benefit of the dividend.

Dated 23 January 1986

**MICHAEL W. E. HOSKING**, Liquidator  
Hosking Goldberg & Co., certified practising accountants, 1st Floor, 10-12 York Street, South Melbourne, 3205. Telephone: 690 6466 1518

Companies Act 1961

Section 272

**KEANE SANTOS VAWSER PTY. LTD.**

(In Liquidation)

Notice Convening Final Meeting of Members and Creditors

Notice is hereby given pursuant to section 272 of the Companies Act 1961 that a General Meeting of the members and creditors of the abovenamed company will be held at the offices of Ferrier Hodgson & Co., 24th Floor, 459 Collins Street, Melbourne, on Friday, 28 February 1986 at 10.00 a.m. for the purpose of having an account laid before them showing the manner in which the winding up has been conducted and the property of the company disposed of and of hearing any explanations that may be given by the Liquidator.

Dated 21 January 1986

1519 **A. G. HODGSON**, Liquidator

The Companies Act 1961

**BOARDGAMES WHOLESALE PTY. LTD.**

(in Liquidation)

Notice of Intention to Declare a First and Final Dividend

Notice is hereby given that a first and final dividend is intended to be declared in the above matter. Creditors who have not proved their debts by 28 February 1986 may be excluded from this dividend. Dated 23 January 1986

**G. O. HARRISON**, Liquidator

Touche Ross & Co., chartered accountants, 525 Collins Street, Melbourne 3000 1520

Notice is hereby given that at a general meeting of the Company duly convened and held at 3rd Floor, 526 Bourke Street, Melbourne or the 20th day of January, 1986 the following special resolution was duly passed:

That the company be wound up voluntarily and that Mr. Colin Boltman of Messrs. Abbott, Stillman and Wilson, 3rd Floor, 526 Bourke Street, Melbourne be appointed liquidator for the purposes of the winding up.

Dated 20 January 1986

1492 **COLIN BOLTMAN**, Director

In the matter of the *Co-operative Housing Societies Act 1958*; and in the matter of Kardinia (No. 8) Co-operative Housing Society Limited—(In Liquidation)

At a Special General Meeting of the above-named Society duly convened and held at the Registered Office, 42 Aberdeen Street, Geelong West on Wednesday 18th December 1985 the subjoined special resolution was duly passed:

That the Society having successfully completed its objectives 102 months ahead of its expected term be wound up voluntarily and that Alan Russell Quick of 42 Aberdeen Street, Geelong West be appointed liquidator for the purposes of the winding up.

Dated 18 December 1985

**R. C. OSBOURNE**, Chairman of Meeting  
1513 **A.R. QUICK**, Secretary

In the matter of the *Co-operative Housing Societies Act 1958*; and in the matter of Kardinia (No. 5) Co-operative Housing Society Limited—(In Liquidation)

At a Special General Meeting of the above-named Society duly convened and held at the Registered Office, 42 Aberdeen Street, Geelong West on Wednesday 18th December 1985 the subjoined special resolution was duly passed—

That the Society having successfully completed its objectives 27 months ahead of its expected term be wound up voluntarily and

that Alan Russell Quick of 42 Aberdeen Street, Geelong West be appointed liquidator for the purposes of the winding up.

Dated 18 December 1985

L. G. OLNEY, Chairman of Meeting  
1514 A. R. QUICK, Secretary

Creditors, next of kin and others having claims in respect of the estate of John Scurr Vost late of 88 Clarence Street, East Brunswick in the State of Victoria, gentleman, deceased who died on 21 August 1985 are requested to send particulars of their claims to the Executors, Michele Masino and Maria Carmela Masino care of Accornero, Brett & Matisi, 407 Brunswick Street, Fitzroy by 11 April 1986 after which date they will distribute the assets having regard only to the claims of which they then have notice.

1499

Creditors, next of kin and others having claims in respect of the estate of Minnie Evelyn Armstrong late of 15 Blamoral Avenue, East Brunswick, in the State of Victoria, widow, deceased, who died on 29 October 1985 are to send particulars of their claims to the executor Victor Harold Armstrong care of the undermentioned solicitors by 30 March 1986 after which date the executor will distribute the assets having regard only to the claims of which he then has notice

LE GRAND, RANGLES, ADAMS & CO.,  
solicitors, 636 Sydney Road, Brunswick 1499

Creditors, next of kin and others having claims in respect of the estate of Melva Myrtle Cochrane late of 56 Robb Street, East Bairnsdale, in the State of Victoria, widow, deceased, who died on 17 November 1985 are to send particulars of their claims to the executor John Leslie Cochrane care of the undermentioned solicitors by 29 March 1986 after which date the executor will distribute the assets having regard only to the claims of which he then has notice

LE GRAND, RANGLES, ADAMS & CO.,  
solicitors, 636 Sydney Road, Brunswick 1500

Creditors, next of kin and others having claims in respect of the estate of Norman Francis Wighton late of "Willowbank" Templestowe Road, Templestowe, in the State of Victoria, printer, deceased, who died on 12 September 1985 are to send particulars of their claims to the executor Beatrice Sheila Wighton care of the undermentioned solicitors by 29 March 1986 after which date the executor will distribute the assets having regard only to the claims of which she then has notice

LE GRAND, RANGLES, ADAMS & CO.,  
solicitors, 636 Sydney Road, Brunswick 1501

ALFRED GEORGE HODGE, late of 29 Thames Promenade, Chelsea, Electrical Technician deceased intestate

Creditors, next of kin and others having claims against the estate of the said deceased (who died on 16 September 1985) are required to send particulars of their claims to Alice Frances Hodge, the mother of the deceased, care of the undersigned Solicitors by 25 March 1986 after which date she will distribute the assets having regard only to the claims of which she has notice.

ALAN WAINWRIGHT J. OKNO & CO. of 213  
Lonsdale Street, Melbourne 1506

MAY LARNER, late of 14 Winterton Court, Wantirna South in the State of Victoria Widow deceased

Creditors, next of kin and others having claims in respect of the estate of the deceased (who died on 23 October 1985) are required by the Executor Richard Patrick Baylor of 1 Walkers Road, Nunawading Solicitor to send particulars to him, care of the undersigned, on or before 15 April 1986, after which date he will distribute the assets having regard only to the claims of which he then has notice.

BAYLOR & CO., Solicitors, 1 Walkers Road,  
Nunawading. 1507

RENNIE McKENZIE, late of "Willowbrook" Willow Road, Ferntree Gully in the State of Victoria, Gentlewoman, deceased

Creditors, next of kin and others having claims in respect of the Estate of the abovenamed deceased who died on 8 May 1985 are required by Alexander Roy McKenzie of 9 Keira Street, Mt. Keira in the State of New South Wales, and Olive Dorothy Nicholas of 19 Adrienne Crescent, Mt. Waverley in the State of Victoria the Executors of the Estate of the said deceased to send particulars of such claims to them in care of the undermentioned Solicitors on or before 26 February 1986, after which date they will distribute the assets having regard only to claims of which they then have notice.

A. E. WUNDELE & CO. Solicitors of 253  
Lonsdale Street, Melbourne. 1508

BRIAN VINCENT TOBIN (deceased), late of 1A Hill Street Port Kembla died on 29 November 1985

Any persons claiming to be dependant upon the deceased are requested to send particulars of their claims to "Life Claims Department, Australian Eagle Insurance Company Limited, GPO Box 1883R, Melbourne 3001" within 2 months from the date of this notice, after which date the deceased's entitlement will be distributed in accordance with the provisions of the Eagle Retirement Fund Trust Deed, having regard only to the claims which have been notified.

1509

DENTON IRENE HOPE, formerly of 8 Hume Street, Armadale, but late of Armadale Lodge, 654 High Street, Armadale, spinster, deceased

Creditors, next of kin and others having claims in respect of the Estate of the abovenamed deceased who died on 17 January 1986 are required to send particulars of their claims to National Trustees Executors and Agency Company of Australasia Limited of 95 Queen Street, Melbourne the Executor named in the Will dated 14 October 1957 on or before 10 April 1986 after which date the said Company will distribute the assets of the said deceased having regard only to the claims of which the Company shall then have had notice. 1522

LAWRENCE LYNEDOCH TURNER GRAHAM, late of 5D Belson Street, East Malvern, in the State of Victoria, company manager, deceased

Creditors, next of kin and others having claims in respect of the deceased who died on 4 August 1984, are requested to send their claims to Christina Graham and John Aldridge Mumford the Executors of the Estate of Laurence Lynedoch Turner Graham, C/- the undersigned solicitor by 31 March 1986, after which date the Executors will proceed to distribute the Estate having regard only to claims of which they then have notice.

BARRY KENNA & CO., solicitors, 695 Burke Road, Camberwell 3124 1523

FRANCIS ROBINSON CONDON, late of 5 Fordham Avenue, Camberwell, in the State of Victoria, retired, deceased

Creditors, next of kin and others having claims in respect of the deceased who died on 27 October 1985, are requested to send their claims to Catherine Patricia Tucker the Executrix of the Estate of Francis Robinson Condon, C/- the undersigned solicitor by 31 March 1986 after which date the Executor having regard only to claims of which she then has notice.

BARRY KENNA & CO., solicitors, 695 Burke Road, Camberwell 3124 1524

Creditors, next of kin and others having claims in respect of the Estate of Henry Prince late of 33 Naples Road, Mentone deceased who died on 29 September 1985 are requested to send particulars of their claims to the Executor The Equity Trustees Executors and Agency Company Limited care of the undermentioned Solicitors on or before 30 March 1986 after which date it will distribute the assets having regard only to the claims of which it then has notice.

McKEAN & PARK, solicitors, 450 Little Collins Street, Melbourne 1525

In the will of SOPHIE AMANDA BERGEN late of 52 Richardson Street, Portland in the State of Victoria Widow deceased

Creditors next of kin and others having claims in respect of the estate of the deceased who died on 8 May 1985 are required by the Union-Fidelity Trustee Company of Australia Limited of 100 Exhibition Street Melbourne the executor named in the said Will and the applicant for a grant of Probate thereof to send particulars of their claims to the said executor at 5 Doveton Street, North Ballarat no later than two months from the date hereof after which date the said executor will distribute the assets having regard only to the claims of which it then has notice.

STRINGER & BIRD, 10 Henty Street, Portland, Solicitors for the said Executor 1495

LEONARD FREDERICK CLIFFORD CHAMBERS late of 65 McCrae Street Dandenong Gentleman deceased

Creditors next of kin and others having claims in respect of the Estate of the deceased who died on 9 August 1985 are required by ANZ Executors & Trustee Company Limited of 94 Queen Street Melbourne the Executor of the Will of the said deceased to send particulars to the Company at its said address by 1 April 1986 after which date the Executor may convey or distribute the assets having regard only to the claims of which it then has notice.

MACPHERSON AND KELLEY, 229 Thomas Street, Dandenong, Solicitors 1497

Creditors, next of kin and others having claims in respect of the Estate of the deceased, Edward Joseph Hillman who died on 15 November 1985 are required by the Executors John Caldwell Gunn to send particulars of their claims in writing to the Executor care of the undermentioned firm of solicitors by 1 April 1986 after which date the executor will distribute the assets having regard only to the claims of which he then has notice.

MAL. RYAN, JACKSON & GLEN, solicitors, 81 Grant Street, Alexandra 1504

Creditors, next of kin and others having claims in respect of the Estate of Kevin John Phelan late of Crowes Road, Portland in the State of Victoria, Builder, who died on 23 March 1985 are required by the Executrix of his Estate, Shelia Anne Rudd of 17 Barnett Street, Hampton in the said State, Home duties to send particulars to her care of the undermentioned Solicitors on or before 31 March 1986 after which date the assets of the Estate will be distributed having regard only to the claims of which the said Executrix had notice.

PATRICK J. HOWMAN & ASSOCIATES, Barristers and Solicitors, 104 Percy Street, Portland 1505

MURIAL ELIZABETH COOK late of Telegraph Road, Rokeby in the State of Victoria, Married Woman, deceased.

Creditors next of kin and others having claims in respect of the estate of the deceased who died on 19 June 1985 are required by the Trustees Walter Charles Cook, Lorna Muriel Reiger and Philip Russell Cook to send particulars of their claims to them care of the undersigned Solicitors by 10 April, 1986 after which date the Trustees may convey or distribute the assets having regard only to the claims of which they then have notice.

GRAY FRIEND & LONG, Solicitors, Warragul  
1496

Creditors, next of kin and others having claims in respect of the Estate of the deceased, Reginald James Savage who died on 10 October 1985 are required by the Executors Betty May Savage and John Caldwell Gunn to send particulars of their claims in writing to the Executors care of the undermentioned firm of solicitors by 1 April 1986 after which date the executors will distribute the assets having regard only to the claims of which they then have notice.

MAL. RYAN, JACKSON & GLEN, solicitors,  
81 Grant Street, Alexandra 1502

Creditors, next of kin and others having claims in respect of the Estate of the deceased, Eileen Dorothy Perkins who died on 22 December 1985 are required by the Executor John Caldwell Gunn to send particulars of their claims in writing to the Executor care of the undermentioned firm of solicitors by 1 April 1986 after which date the executor will distribute the assets having regard only to the claims of which he then has notice.

MAL. RYAN, JACKSON & GLEN, solicitors,  
81 Grant Street, Alexandra 1503

ELLEN GOLIGHTLY, late of 40 Mercer Street, Queenscliff in the State of Victoria Spinster deceased

Creditors next of kin and others having claims in respect of the estate of the abovenamed deceased who died on 25 November 1985 are required by the Trustee The Union-Fidelity Trustee Company of Australia Limited of 100 Exhibition Street Melbourne to send particulars of their claims to the Trustee care of the undermentioned solicitors by 20 March, 1986 after which date the Trustee may convey or distribute the assets having regard only to the claims of which they then have notice.

INGPEN & BENT, Solicitors, 95 Yarra Street,  
Geelong Solicitors for the Trustee 1494

JOHN CHRISTOPHER SHERIDAN, late of 36 Jackson Street, Croydon, in the State of Victoria, workshop foreman, deceased

Creditors, next of kin and others having claims in respect of the Estate of the Deceased who died on 30 March 1985 are required by Margaret Elizabeth Sheridan, widow of 36 Jackson Street, Croydon the Executor to whom Probate of the Will of the said Deceased was granted by the Supreme Court of Victoria to send particulars to her care of the under-signed by 8 April 1986 after which date the said Executor may convey or distribute the assets having regard only to the claims of which she then has notice

PATRICK J. CANNON, COBURN &  
ASSOCIATES, solicitors, of 205 Hampshire Road,  
Sunshine 1515

ANGELO GROTTO, late of Boundary Bend in  
the State of Victoria, widow, deceased

Creditors, next of kin and other persons having claims against the Estate of the said deceased who died on 1 December, 1984 are required to send particulars of same to the Executor Vittorio Grotto in care of the undersigned on or before 25 March, 1986 after which date he will distribute the assets having regard only to the claims of which he then has notice.

DWYER, BENNETT & MAHON, barristers and  
solicitors, 194-208 Beveridge Street, Swan Hill  
1516

DAVID JOHN PREBBLE, late of 40 Royal Road,  
Bonbeach, technical contact man deceased (who  
died on 8 October, 1985)

Creditors, next of kin and all others persons having claims against the estate of the deceased are required to send particulars of their claims to Pamela Ann Pope in care of Ryan & Kee, solicitors of 154 Commercial Road, Yarram, on or before 6 April 1986 after which date she will distribute the assets having regard only to the claims of which she then has notice.

RYAN & KEE, solicitors, 154 Commercial Road,  
Yarram 1517

WATSON CYRIL HERBERT, formerly of 4/1  
Dalgetty Street, St. Kilda, but late of 6/21 Mark  
Street, North Melbourne, in the State of Victoria,  
retired hotel employee, deceased

Creditors, next of kin and others having claims in respect of the Estate of the abovenamed deceased who died on 20 October, 1985 are required to send particulars of their claim to the Executor, National Trustees Executors and Agency Company of Australasia Limited of 95 Queen Street, Melbourne on or before 10 April, 1986 after which date the said Company will distribute the assets of the said deceased having regard only to the claims of which it shall have had notice.

1521

CHARLES FRANCIS JONES late of 22 Wilsons Road, Mornington, in the State of Victoria, gentleman, deceased

Creditors, next of kin and others having claims in respect of the estate of the deceased who died on 22 October 1985 are required by The Perpetual Executors and Trustees Association of Australia Limited of 50 Queen Street, Melbourne to send particulars of their claims to the said Company by Friday 11 April 1986 after which date it will convey or distribute the assets having regard only to the claims of which the Company then has notice.

BEST HOOPER, solicitors, 400 Little Collins Street, Melbourne 1526

Creditors, next of kin and others having claims in respect of the estate of Florence Muriel Langdon, late of 758 Elgar Road, Doncaster, widow, deceased are to send particulars of their claim to Mark Ian Langdon the executor of the will of the deceased care of the undermentioned solicitors by 1 April 1986 after which date the executor will distribute the assets having regard to the claims of which he then has notice.

R. WADHAM & DOIG, solicitors, 430 Little Collins Street, Melbourne 1527

Creditors, next of kin and others having claims in respect of the estate of Desmond John Craven, late of 128 Market Street, Essendon, retired tram driver deceased, who died on 20 December 1985 are to send the particulars of their claims to ANZ Executors & Trustee Company Limited of 94 Queen Street, Melbourne by 17 April 1986 after which date it will distribute the assets having regard only to the claims on which it then has notice. 1528

OSMAN ROBERT FORTUNE, late of Ararat Hospital, Ararat, retired deceased who died on 9 July, 1985

Claims to the Executor Alan Howard Gray of 188 High Street, Northcote by 23 March 1986 1481

RICHARD DONALD ROBINSON, late of 12 Yarrabee Court, Mount Waverley, who died on 13 January 1985

Creditors, next-of-kin and all others having claims in respect of the said deceased are requested by the executors Frederick Archdale Lester of 14 Houghton Road, Oakleigh and National Trustees Executors and Agency Company of Australasia Limited of 95 Queen Street, Melbourne to send particulars of such claims addressed to the executors care of National Trustees Executors and Agency Company of Australasia at 95 Queen Street, Melbourne by 31 March 1986 after which date the executors will distribute the assets having regard only to the claims which they then have notice.

LESTER, FIELDEN & FARAONE, solicitors, 14 Houghton Road, Oakleigh 1480

MAUD JAMIESON MEADWAY, late of 63 Bowen Road, Sorrento in the State of Victoria, Retired Bank Officer, deceased

Creditors, next of kin and others having claims in respect of the estate of the deceased who died on 11 September 1985 are required by the Trustees National Trustees Executors and Agency Company of Australasia Limited of 95 Queen Street Melbourne and Janet Stewart of 5 Milner Road, Alice Springs, Northern Territory, Nurse to send particulars to them care of National Trustees Executors and Agency Company of Australasia Limited by 2 April 1986 after which date the Trustees may convey or distribute the assets having regard only to the claims of which they then have notice. 1485

LORNA MULLER STEWART, late of 2 Gascoyne Street, Canterbury, in the State of Victoria, deceased

Creditors, next of kin and others having claims in respect of the Estate of the deceased who died on 16 January 1985 are required by The Union-Fidelity Trustee Company of Australia Limited of 100 Exhibition Street, Melbourne, the Executor to whom Probate has been granted of the Will of the abovenamed deceased to send particulars of their claims to the said Executor by 31 March 1986 after which date the said Executor will convey or distribute the assets having regard only to the claims of which it has notice.

THE UNION-FIDELITY TRUSTEE COMPANY OF AUSTRALIA LIMITED, 100 Exhibition Street, Melbourne 1486

Creditors next of kin and others having claims in respect of the Estate of Emily Mary Ryan late of 7 Winmalee Road, Balwyn in the State of Victoria who died on 6 January 1986 are required to send particulars of their claims to the Executor William Gerard Ryan care of the undersigned Solicitors before 31 March 1986 after which date the assets of the Estate will be distributed having regard only to the claims of which the Executor has notice.

I. M. WHITE, 2 Watson Road, Mount Martha 1483

Creditors, next of kin and others having claims in respect of the estate of Mark Francis John Flynn late of 1 Clarke Street, Glen Iris, builder, deceased, who died on 14 July 1985 are required to send particulars to the executor Martin Leo Smith care of the address mentioned hereunder by 2 April 1986 after which date the executor shall convey or distribute the assets having regard only to the claims of which he then has notice.

HERBERT, GEER & RUNDLE, solicitors, 385 Bourke Street, Melbourne 1531

Creditors, next of kin and others having claims against Hugh Alexander Mitchell late of 83 Chapman Avenue, Glenroy in the State of Victoria retired deceased who died on 24 October 1985 are required by the Executor The National Trustees Executors and Agency Company of Australasia Limited of 95 Queen Street, Melbourne in the State to send particulars of their claims to the said Executor at its office at 95 Queen Street, Melbourne by 28 March 1986 after which date it will distribute the assets of the said estate having regard only to the claims of which they then have notice.

MAURICE J. BROPHY, O'DEA & CO.,  
solicitors of 334 Sydney Road, Coburg 1484

Creditors, next of kin and others having claims in respect of the estate of Benjamin Lewis Dixie late of 21 Brighton Street, Richmond in Victoria retired deceased who died on 6 September 1985 are hereby required to send particulars of their claims to Jean Dowling and Lesley Ash The Executors of his estate care of the undermentioned Solicitors by 31 March 1986 after which date they will distribute the assets having regard only to the claims of which they then have had notice.

L'ESTRANGE & KENNEDY, solicitors, 291  
Bridge Road, Richmond 1482

In the Supreme Court of Victoria  
SALE BY THE SHERIFF

On 13 March 1986 at 2.30 p.m. at the Sheriff's Office, Writs and Warrants Division 287 Springvale Road, Glen Waverley (unless process be stayed or satisfied) all the estate and interest (if any) in and to the following:

Giuseppe Galati and Maria Galati of 82 Thompsons Road, Bulleen joint proprietors of an estate in fee simple in the land described in Certificate of Title Volume 8151 Folio 833 upon which is erected a dwelling and known as 82 Thompsons Road, Bulleen.

Registered Mortgage F988400 and Caveat G175617.

Dwayne John Cartier and Glenys Margaret Cartier of 21 Bernard Drive, Melton South as joint proprietors of an estate in fee simple in the land described in Certificate of Title Volume 8522 Folio 578 upon which is erected a dwelling and known as 21 Bernard Drive, Melton South.

Registered Mortgage J526325 and Caveats J736918, K517834, L571805T.

Any Mortgages and/or other Dealings specified may affect the said Estate and Interest.

Terms—Cash Only

1530 A. STANLEY, Tel: 566 4700

In the Supreme Court of Victoria  
SALE BY THE SHERIFF

On 6 March 1986 at 2.30 p.m. at the Sheriff's Office, Writs and Warrants Division 287 Springvale Road, Glen Waverley (unless process be stayed or satisfied) all the Estate and Interest (if any) in and to the following:

Peter Alevizos of 324 Albion Street, West Brunswick shown on Certificate of Title as Panagiotis Alevizos with Helen Alevizos as joint proprietors of an estate in fee simple in the land described in Certificate of Title Volume 9480 Folio 748 upon which is erected a two storey brick structure with residence at rear and known as 322-324 Albion Street, West Brunswick.

Registered Mortgages J222458, L111953D and Caveat K162147

Bernard Peterzen of Disney Street, Crib Point proprietor of an estate in fee simple in the land described in Certificate of Title Volume 9421 Folio 439 which is vacant land and known as part of Lot 52 and 57 Tyabb-Tooradin Road, Tyabb starting 922.1 metres North East from Denham Road on the South Side.

Registered Mortgage J987571

James Hamilton of 50 Anora Crescent, Mulgrave shown on Certificate of Title as James Malcolm Hamilton Joint Proprietor with Courtney Ruth Hamilton of an Estate in fee simple in the land described in Certificate of Title Volume 8765 Folio 099 subject to the Covenant contained in Transfer E58737 upon which is erected a dwelling and known as 50 Anora Crescent, Mulgrave.

Registered Mortgage E108938.

Any Mortgages and/or other Dealings specified may affect the said Estate and Interest.

Terms—Cash Only

1529 A. STANLEY, Tel: 566 4700

LATE NOTICES

Co-operative Housing Societies Act 1958  
NOTICE OF AMALGAMATION OF  
SOCIETIES

Notice is hereby given that, pursuant to the provisions of the *Co-operative Housing Societies Act 1958*:

Werribee (No. 11) Co-operative Housing Society  
Limited,

Werribee (No. 12) Co-operative Housing Society  
Limited,



Werribee (No. 13) Co-operative Housing Society Limited,  
 Werribee (No. 14) Co-operative Housing Society Limited, and  
 Werribee (No. 15) Co-operative Housing Society Limited,  
 were amalgamated into one society under the name of Werribee (No. 17) Co-operative Housing Society Limited on 1 January 1986  
 Dated at Melbourne, 1 January 1986

M. F. G. BENDLE  
 Acting Deputy Registrar of  
 Co-operative Housing Societies

*Co-operative Housing Societies Act 1958*

NOTICE OF AMALGAMATION OF SOCIETIES

Notice is hereby given that, pursuant to the provisions of the *Co-operative Housing Societies Act 1958*:

Security (No. 19) Co-operative Housing Society Limited,  
 Security (No. 28) Co-operative Housing Society Limited,  
 Security (No. 29) Co-operative Housing Society Limited,  
 Security (No. 35) Co-operative Housing Society Limited,  
 Security (No. 36) Co-operative Housing Society Limited,  
 Security (No. 37) Co-operative Housing Society Limited,  
 Security (No. 38) Co-operative Housing Society Limited,  
 Security (No. 39) Co-operative Housing Society Limited,  
 Security (No. 40) Co-operative Housing Society Limited,  
 Ballarat Young Workers (No. 2) Co-operative Housing Society Limited,  
 Ballarat Young Workers (No. 3) Co-operative Housing Society Limited, and  
 Hawthorn (No. 14) Co-operative Housing Society Limited,

were amalgamated into one society under the name of Security (No. 42) Co-operative Housing Society Limited on 1 January 1986.

Dated at Melbourne, 1 January 1986

M. F. G. BENDLE  
 Acting Deputy Registrar of  
 Co-operative Housing Societies

COUNTRY FIRE AUTHORITY

Permission to Hold Fire Brigade Demonstrations

In pursuance of the provisions of section 103 of the *Country Fire Authority Act 1958*, the Country Fire Authority has granted permission for the holding of fire brigade demonstrations as under:

*Rural Fire Brigades*

At Buangor on Sunday, 2 March 1986  
 At Murrayville on Sunday, 2 March 1986  
 At Geelong on Sunday, 16 March 1986  
 At Napoleons on Sunday, 16 March 1986

23 January 1986

M. RIDDELL  
 Manager, Finance and Administration

*Transport Act 1983*

ROAD TRAFFIC AUTHORITY

Commercial Passenger and Goods Vehicle Applications

Notice is hereby given that the following applications will be considered by the Road Transport Authority on 18 February 1986.

Notice of any objections should be forwarded to reach either the Manager Vehicle Licensing Branch or any Regional Office of the Road Traffic Authority not later than 12 February 1986.

It will not be necessary for interested parties to appear on the hearing date specified, unless advised in writing by the Authority.

Notification of the date for consideration of applications which are objected to and which require determination by the Road Transport Licensing Tribunal will be published by further notice in this Gazette.

Laffan Bros. Pty. Ltd., Wallan. Application to licence a class 1 tow truck to operate throughout the State of Victoria from a depot located at Northern Highway, Wallan for the purpose of lifting and carrying or towing damaged or disabled motor cars, but excluding the ability to attend the scene of a motor car accident in a "Controlled Area".

R. Leemann, Plenty. Application to licence five commercial passenger vehicles in respect of a 1960 Bentley sedan, a 1957 Rolls Royce sedan, a 1952 Jaguar convertible and 1949 and 1950 Jaguar sedans each with seating capacity for 4 passengers to operate as special purpose vehicles from Lot 6, Cullen Crescent, Plenty for the carriage of passengers for wedding parties within the Melbourne metropolitan area.

J. McInerney, North Melbourne. Application to licence four commercial passenger vehicles in respect of a 1979 stretched Ford Lincoln limousine with seating capacity for 7 passengers, a 1979 stretched Leyland Mini and two 1979 Cadillac

sedans each with seating capacity for 5 passengers to operate as metropolitan hire cars from 4 Trafalgar Place, North Melbourne.  
Dated 29 January 1986

G. J. MENARY  
Group Manager  
Licensing and Research

**NOTICE OF MAKING OF  
STATUTORY RULES  
WHICH ARE NOT YET  
AVAILABLE**

Notice is given of the making of the following Statutory Rules:

No.	<i>Motor Boating Act 1961</i>
5/1986	Motor Boating (Lake Boga) Regulations 1986
	<i>Trustee Act 1958</i>
7/1986	Trustee (Approved Insurers) Regulations 1986
	<i>Scaffolding Act 1971</i>
16/1986	Scaffolding (Board of Examiners Fees and Travelling Expenses) (Amendment No. 3) Regulations 1986
	<i>Construction Industry Long Service Leave Act 1983</i>
17/1986	Construction Industry Long Service Leave (Construction Industry Long Service Leave Board Fees and Allowances) (Amendment No. 3) Regulations 1986
	<i>Boilers and Pressure Vessels Act 1970</i>
18/1986	Boilers and Pressure Vessels (Steam Engine Drivers and Boiler Attendants) (Amendment No. 3) Regulations 1985
	<i>Boilers and Pressure Vessels Act 1970</i>
19/1986	Boilers and Pressure Vessels (Board of Examiners for Welders of Boilers and Pressure Vessels Fees and Travelling Allowances) (Amendment No. 3) Regulations 1986

	<i>Health Act 1958</i>
20/1986	Health (Cinematograph Operators) (Fees Amendment) Regulations 1986
	<i>Lifts and Cranes Act 1967</i>
21/1986	Lifts and Cranes (Appeals) (Fees and Expenses) (Amendment No. 3) Regulations 1986
	<i>Shearers Accommodation Act 1976</i>
22/1986	Shearers Accommodation (Appeal Board Travelling Expenses and Allowances) Regulations 1986
	<i>Youth Sport and Recreation Act 1972</i>
23/1986	Youth Sport and Recreation (Council Fees and Allowances) (Amendment No. 2) Regulations 1986
	<i>Liquor Control Act 1968</i>
31/1986	Liquor Control (Fees) Regulations 1986

**NOTICE OF MAKING  
AND AVAILABILITY OF  
STATUTORY RULES**

In pursuance of the provisions of the *Subordinate Legislation Act 1962* and the Regulations made thereunder notice is given of the making and availability of the following Statutory Rules:

Note: The date specified after each Statutory Rule is the date it was first obtainable from the Victorian Government Bookshop, 41 St Andrew's Place, East Melbourne.

No.	<i>Local Authorities Superannuation Act 1958</i>	Price
4/1986	Local Authorities Superannuation (Amendment) Regulations 1986, No. 16	
24 January 1986		40c

### Publications Availability

Publications may be purchased from the  
**Victorian Government Bookshop**  
 41 St Andrews Place East Melbourne  
 (PO Box 203 North Melbourne 3051)  
 Telephone Inquiries (03) 320 0299

#### Mail Orders and Postage

A postage and packaging fee must be added to the cost of the requested publication using the table of rates below. Remittances should be made payable to the 'Victorian Government Printing Office'.

#### Bankcard

Purchases may be made using Bankcard facilities in the Bookshop and by mail order. Bankcard mail orders require the Bankcard number, expiry date, name, address and signature of customer to be supplied. (Minimum purchase of \$5.00 applies).

<i>Total Price of Publications</i>	<i>Postage Packaging Fee</i>
\$ 0.00 to \$ 2.00 .. ..	\$ 0.80
\$ 2.05 to \$ 5.00 .. ..	\$ 1.10
\$ 5.05 to \$ 25.00 .. ..	\$ 2.50
\$ 25.05 to \$ 75.00 .. ..	\$ 3.00
\$ 75.05 to \$125.00 .. ..	\$ 3.50
\$125.05 to \$200.00 .. ..	\$ 4.00
\$200.05 and over .. ..	at cost

### General Information

The following guidelines should be followed for the publication of official material in the *Victoria Government Gazette*.

**Publication of official material**

- Duplicate copies should be submitted for the use of the Gazette Officer.
- Material submitted to the Executive Council for Gazettal will normally be published in the next week's issue.
- Where urgent gazettal is required, special arrangements should be made with the:  
Gazette Officer  
Department of the Premier and Cabinet  
Ground Floor  
Old Treasury Building Spring Street  
Melbourne 3000  
Telephone Inquiries (03) 651 1164

**Publication of other material**

- All other material authorized by a responsible officer should be forwarded to the Gazette Officer no later than 9.30 a.m. on Tuesday.
- Lengthy or complicated notices should be forwarded several days before publication.
- Proofs will be supplied only when requested or at the direction of the Gazette Officer. They should be returned quickly to avoid delay in publication.
- No additions or amendments to material for publication will be accepted by telephone.

**Late Copy**

Copy received after 3.30 p.m. on the day prior to publication at the Victorian Government Printing Office will be placed in the following issue of the *Victoria Government Gazette*, irrespective of any date/s mentioned in the copy.

### Publication Details

The *Victoria Government Gazette* is published every Wednesday, unless otherwise advertised.

**Copy Deadline**

Private advertisements will be accepted by:  
Gazette Advertising  
Victorian Government Printing Office  
PO Box 203 North Melbourne 3051, no later than 1 p.m. on the day before publication.

**Advertising Rates**

Single column × cm/part cm .....\$3.35  
Double column × cm/part cm .....\$6.70  
Full page.....\$157.50

Ordinary rates will apply to material submitted for publication before 1 p.m. Tuesday. Double rates will apply for material submitted between 1 p.m. and 3.30 p.m. Tuesday.

**Advertisers should note:**

- There are approximately 30 words to each column centimetre depth;
- Signatures (in particular) and proper names must be written clearly in the text;
- Advertising material should be double-spaced and confined to ONE SIDE ONLY of each sheet of paper
- Documents NOT CLEARLY PREPARED will be returned to the sender, unpublished.

**Correspondence**

All correspondence should be addressed to:  
Gazette Advertising  
Victorian Government Printing Office  
PO Box 203 North Melbourne 3051  
Telephone Inquiries (03) 320 0100

### Agents

The following have been appointed agents to receive advertisements for the *Victoria Government Gazette* :

- Armstrong's Communications Pty Ltd  
191 Queen Street Melbourne 3000
- Blane's Authorized Newsagents 162 Murray  
Street Colac 3250
- Cornell R G 126 Eighth Street Mildura 3500
- Franks H and Co 184 Ryrie Street Geelong  
3220
- Gordon and Gotch Australasia Ltd  
25-37 Huntingdale Road Burwood 3125
- Harston, Partridge & Co. Pty Ltd 455 Little  
Collins Street Melbourne 3000
- Kyneton Guardian Pty Ltd PO Box 18  
Kyneton 3444
- The Mercantile Exchange 50 Queen Street  
Melbourne 3000
- Bridgemall Newsagency 63 Bridgemall Road  
Ballarat 3350
- McGill's Authorized Newsagency 183-185  
Elizabeth Street Melbourne 3000
- McNaughton P R and L A 112-114  
Gray Street Hamilton 3300
- Powney's Authorized Newsagency 293  
Hargreaves Street Bendigo 3550
- Purdie J & Co. 138 Moorabool Street  
Geelong 3220
- Vernons of Richmond 261 Bridge Road  
Richmond 3121

<b>CONTENTS</b>
-----------------

	Page
Appointments	232
Cemeteries—Scale of Fees	218
Contracts	213
Contracts Accepted—Amendments	211
Estates of Deceased Persons	221
Government Notices	211
Late Notices	262
Notice of Making of Statutory Rules	264
Orders in Council—	
Acts—Crown Land (Reserves); Local Government; Audit; Water; Motor Car; Dentists; Weights and Measures; Building Societies; Water and Sewerage Authorities (Restructuring)	233 et seq
Police Sale	214
Private Advertisements	251
Proclamations	208
Resignations	233
Tenders	250

