



# Victoria Government Gazette

No. 56—Wednesday, 9 July 1986

## PROCLAMATIONS

*Public Service Act 1974*  
**PUBLIC HOLIDAY**

### PROCLAMATION

By His Excellency the Governor of the State of Victoria and its Dependencies in the Commonwealth of Australia, &c., &c., &c.

In pursuance of the powers conferred by section 71 (2) of the *Public Service Act 1974*, I, the Governor of the State of Victoria, in the Commonwealth of Australia, by and with the advice of the Executive Council of the said State, do by this my Proclamation appoint the day and date mentioned hereunder to be observed as a Public Half-Holiday at the place specified:

*Public Half-Holiday from the Hour of Twelve Noon*  
Tuesday, 4 November 1986, Within the City of Horsham.

Given under my Hand and the Seal of the State of Victoria aforesaid, at Melbourne, this first day of July in the year of our Lord One thousand nine hundred and eighty-six and in the thirty-fifth year of the reign of Her Majesty Queen Elizabeth the Second, Queen of Australia.

(L.S.) J. DAVIS McCAUGHEY

By His Excellency's Command

S. M. CRABB  
Minister for Labour

GOD SAVE THE QUEEN!

*Public Service Act 1974*  
**PUBLIC HOLIDAY**

### PROCLAMATION

By His Excellency the Governor of the State of Victoria and its Dependencies in the Commonwealth of Australia, &c., &c., &c.

In pursuance of the powers conferred by section 71 (2) of the *Public Service Act 1974*, I, the Governor of the State of Victoria, in the Commonwealth of

Australia, by and with the advice of the Executive Council of the said State, do by this my Proclamation appoint the day and date mentioned hereunder to be observed as a Public Half-Holiday at the place specified:

*Public Half-Holiday from the Hour of Twelve Noon*  
Tuesday, 4 November 1986, Within the City of Wangaratta.

Given under my Hand and the Seal of the State of Victoria aforesaid, at Melbourne, this first day of July in the year of our Lord One thousand nine hundred and eighty-six and in the thirty-fifth year of the reign of Her Majesty Queen Elizabeth the Second, Queen of Australia.

(L.S.) J. DAVIS McCAUGHEY

By His Excellency's Command

S. M. CRABB  
Minister for Labour

GOD SAVE THE QUEEN!

## PUBLIC HIGHWAY—CITY OF FRANKSTON

### PROCLAMATION

By His Excellency the Governor of the State of Victoria and its Dependencies in the Commonwealth of Australia, &c., &c., &c.

Whereas by the *Local Government Act 1958*, section 519 it is amongst other things enacted that it shall be lawful for the Governor in Council at any time and from time to time upon the request of the council of any municipality by notice in the *Government Gazette* to proclaim any land reserved used or by purchase or exchange acquired for a street road highway thoroughfare bridge square court alley or right-of-way or any street road lane or passage made or laid out or proposed to be made or laid out on any land of which a plan of subdivision delineating that street road lane or passage has been sealed with the seal of the municipality under subdivision (3) of Division 9 of Part XIX of the *Local Government Act 1958* or a corresponding previous enactment to be a public highway and that such land shall thereupon and thenceforth from the date of such proclamation become and be absolutely dedicated to the public as a public highway within the meaning of any law then or thereafter in force.

And whereas the Council of the City of Frankston has requested that the land hereinafter mentioned, being a street road lane or passage made or laid out or proposed to be made or laid out on land of which a plan of subdivision delineating such street road lane or passage has been sealed with the seal of the municipality under subdivision (3) of Division 9 of Part XIX of the *Local Government Act 1958*, or a corresponding previous enactment be so declared to be a public highway.

Now therefore, I, the Governor of the State of Victoria in the Commonwealth of Australia, by and with the advice of the Executive Council of the said State, do by this proclamation declare that Somerset Road, Frankston coloured brown on Plan of Subdivision No. 12565 shall be a public highway within the meaning of the said Act.

Given under my Hand and the Seal of the State of Victoria aforesaid, at Melbourne, this first day of July in the year of our Lord One thousand nine hundred and eighty-six and in the thirty-fifth year of the reign of Her Majesty Queen Elizabeth the Second, Queen of Australia.

(L.S.) J. DAVIS McCAUGHEY

By His Excellency's Command

J. L. SIMMONDS

Minister for Local Government

GOD SAVE THE QUEEN!

**PUBLIC HIGHWAY—SHIRE OF BARRABOOL**

**PROCLAMATION**

By His Excellency the Governor of the State of Victoria and its Dependencies in the Commonwealth of Australia, &c., &c., &c.

Whereas by the *Local Government Act 1958*, section 519 it is amongst other things enacted that it shall be lawful for the Governor in Council at any time and from time to time upon the request of the council of any municipality by notice in the *Government Gazette* to proclaim any land reserved used or by purchase or exchange acquired for a street road highway thoroughfare bridge square court alley or right-of-way or any street road lane or passage made or laid out or proposed to be made or laid out on any land of which a plan of subdivision delineating that street road lane or passage has been sealed with the seal of the municipality under subdivision (3) of Division 9 of Part XIX of the *Local Government Act 1958* or a corresponding previous enactment to be a public highway and that such land shall thereupon and thenceforth from the date of such proclamation become and be absolutely dedicated to the public as a public highway within the meaning of any law then or thereafter in force.

And whereas the Council of the Shire of Barrabool has requested that the land hereinafter mentioned, being a street road lane or passage made or laid out or proposed to be made or laid out on land of which a plan of subdivision delineating such street road lane or passage has been sealed with the seal of the municipality under subdivision (3) of Division 9 of Part XIX of the *Local Government Act 1958*, or a corresponding previous enactment be so declared to be a public highway.

Now therefore, I, the Governor of the State of Victoria in the Commonwealth of Australia, by and with the advice of the Executive Council of the said State, do by this proclamation declare that Brent Avenue, Aireys Inlet shown by hatching on the plan hereunder, shall be a public highway within the meaning of the said Act.

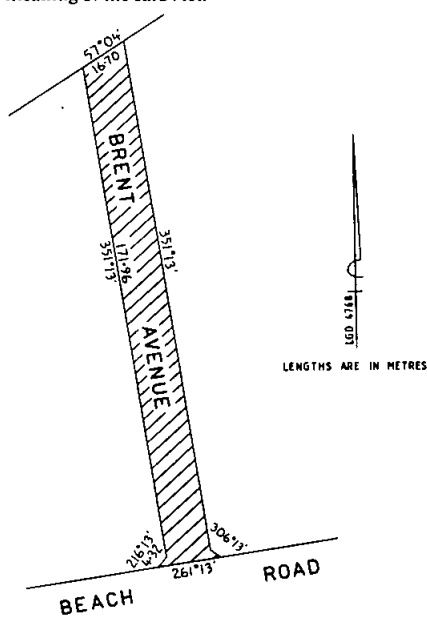

Given under my Hand and the Seal of the State of Victoria aforesaid, at Melbourne, this first day of July in the year of our Lord One thousand nine hundred and eighty-six and in the thirty-fifth year of the reign of Her Majesty Queen Elizabeth the Second, Queen of Australia.

(L.S.) J. DAVIS McCAUGHEY

By His Excellency's Command

J. L. SIMMONDS

Minister for Local Government

GOD SAVE THE QUEEN!

**PUBLIC HIGHWAY—CITY OF FRANKSTON**

**PROCLAMATION**

By His Excellency the Governor of the State of Victoria and its Dependencies in the Commonwealth of Australia, &c., &c., &c.

Whereas by the *Local Government Act 1958*, section 519, it is amongst other things enacted that it shall be lawful for the Governor in Council at any time and from time to time upon the request of the council of any municipality by notice in the *Government Gazette* to proclaim any land reserved used or by purchase or exchange acquired for a street road highway thoroughfare bridge square court alley or right-of-way or any street road lane or passage made or laid out or proposed to be made or laid out on any land of which a plan of subdivision delineating that street road lane or passage has been sealed with the seal of the municipality under subdivision (3) of Division 9 of Part XIX. of the *Local Government Act 1958* or a corresponding previous enactment to be a public highway and that such land shall thereupon and thenceforth from the date of such proclamation become and be absolutely dedicated to the public as a public highway within the meaning of any law then or thereafter in force;

And whereas the Council of the City of Frankston has requested that the land hereinafter mentioned, being a street road lane or passage made or laid out

or proposed to be made or laid out on land of which a plan of subdivision delineating such street road lane or passage has been sealed with the seal of the municipality under subdivision (3) of Division 9 of Part XIX. of the *Local Government Act 1958*, or a corresponding previous enactment be so declared to be a public highway;

Now therefore, I, the Governor of the State of Victoria in the Commonwealth of Australia, by and with the advice of the Executive Council of the said State, do by this proclamation declare that a road off Grandview Grove, Frankston as shown by hatching on the plan hereunder shall be a public highway within the meaning of the said Act.

Given under my Hand and the Seal of the State of Victoria aforesaid, at Melbourne, this first day of July in the year of our Lord One thousand nine hundred and eighty-six and in the thirty-fifth year of the reign of Her Majesty Queen Elizabeth the Second, Queen of Australia.

(L.S.) J. DAVIS McCAUGHEY

By His Excellency's Command

J. L. SIMMONDS  
Minister for Local Government

GOD SAVE THE QUEEN!

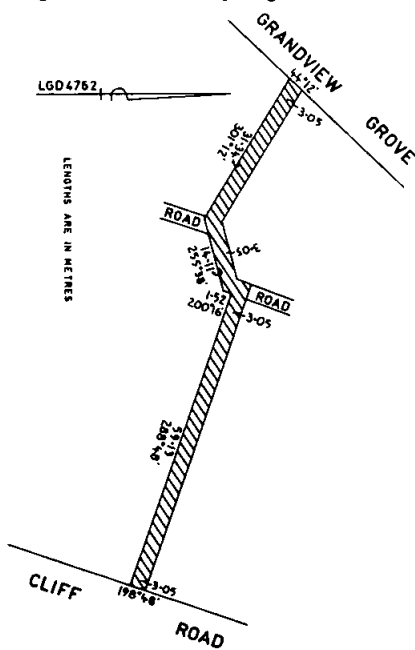

**PUBLIC HIGHWAY—SHIRE OF HASTINGS**

**PROCLAMATION**

By His Excellency the Governor of the State of Victoria and its Dependencies in the Commonwealth of Australia, &c., &c., &c.

Whereas by the *Local Government Act 1958*, section 519, it is amongst other things enacted that it shall be lawful for the Governor in Council at any time and from time to time upon the request of the council of any municipality by notice in the *Government Gazette* to proclaim any land reserved used or by purchase or exchange acquired for a street road highway thoroughfare bridge square court alley or right-of-way or any street road lane or passage made or laid out or proposed to be made or laid out on any land of which a plan of subdivision delineating that street road lane or passage has been sealed with the seal of the municipality under subdivision (3) of Division 9 of Part XIX. of the *Local Government Act 1958* or a corresponding previous enactment to be a public highway and that such land shall thereupon and thenceforth from the date of such proclamation become and be absolutely dedicated to the public as a public highway within the meaning of any law then or thereafter in force;

And whereas the Council of the Shire of Hastings has requested that the land hereinafter mentioned, being a street road lane or passage made or laid out or proposed to be made or laid out on land of which

a plan of subdivision delineating such street road lane or passage has been sealed with the seal of the municipality under subdivision (3) of Division 9 of Part XIX. of the *Local Government Act 1958*, or a corresponding previous enactment be so declared to be a public highway;

Now therefore, I, the Governor of the State of Victoria in the Commonwealth of Australia, by and with the advice of the Executive Council of the said State, do by this proclamation declare that part of Tonkins Road, Red Hill South as shown on the plan hereunder shall be a public highway within the meaning of the said Act.

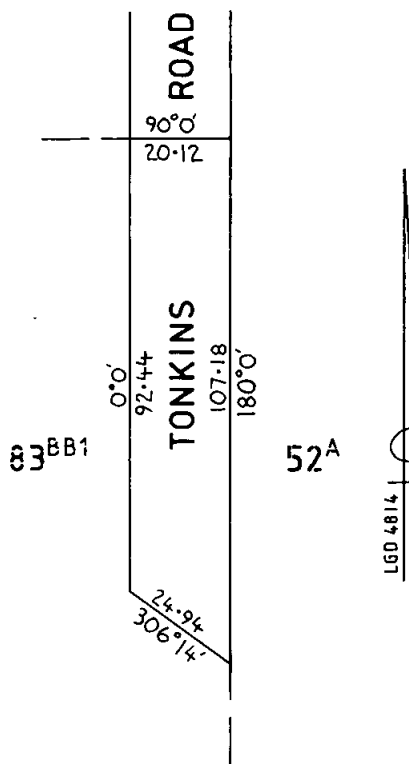

LENGTHS ARE IN METRES

Given under my Hand and the Seal of the State of Victoria aforesaid, at Melbourne, this first day of July in the year of our Lord One thousand nine hundred and eighty-

six and in the thirty-fifth year of the reign of Her Majesty Queen Elizabeth the Second, Queen of Australia.

(L.S.) J. DAVIS McCAUGHEY  
By His Excellency's Command

J. L. SIMMONDS  
Minister for Local Government  
GOD SAVE THE QUEEN!

**GOVERNMENT NOTICES**

**VICTORIAN NURSING COUNCIL  
ELECTIONS 1986**

The following persons have been nominated as candidates for election as members of the Victorian Nursing Council.

*Registered General Nurses*

Elsie June Allen  
Dorothy Rae Anstee  
Valerie Blanksby  
Norma Elizabeth Bryan  
Margaret Anne Higginbotham  
Margaret Mary McKinnon  
Robyn Diane Millership  
Mary Elizabeth Patten  
Margaret Anne Robinson  
Raymond Paul Thomas  
Annick Alfreda Vallily  
Ann Mary Woodruff

*Registered Midwives*

Pamela Joan Kilpatrick  
Agnes McArthur

*Registered Psychiatric Nurses or Mental Retardation Nurses*

Michael Andrew Leighton  
Pauline Scott

*Registered State Enrolled Nurses*

Teresa Armstrong  
Kathleen Grace Bailey  
Jennifer Rosemary Jenz

Polls for the election of six Registered General Nurses, one Registered Midwife, one Registered Psychiatric Nurse or Mental Retardation Nurse, and two Registered State Enrolled Nurses, will be held, in accordance with the Nursing Council Regulations, on 27 August 1986.

No duly completed nomination was received for the election of a Registered Mothercraft Nurse for election as a member of the Victorian Nursing Council.

30 June 1986

E. L. RICHARDSON  
Returning Officer

**MURDER  
REWARD  
\$50 000**

The co-operation of the general public is sought with a view to establishing the identity of the person or persons responsible for the deaths of Brendon Wilson and Arvind Chandran, whose bodies were found at 1/666 Lygon Street, Carlton, on 31 May 1985.

A reward of fifty thousand dollars (\$50 000) will be paid, at the discretion of the Chief Commissioner of Police, by the Government of Victoria for information leading to the apprehension and conviction of the person or persons responsible for these murders.

Any information, which will be treated as confidential, may be given at any time of the day or night to the Officer in Charge, Criminal Investigation Branch, St. Kilda Road Police Complex (telephone 265 2111), or to the Officer in Charge of any Police Station.

C. R. T. MATHEWS  
Minister for Police and Emergency Services

Ministry for Police and Emergency Services  
Melbourne, 30 June 1986

*Workers Compensation Act 1958*

**NOTICE OF NEW BENEFIT RATES PAYABLE IN ACCORDANCE WITH SECTION 9**

Whereas section 9 (3) of the *Workers Compensation Act 1958* provides for rates of compensation to be adjusted on 1 July in any year in line with movements in the Australian male average weekly earnings between the December quarters of the two preceding years, as publicized by the Australian Statistician at 15 June in each respective year.

And whereas the Australian male average weekly earnings for the December quarter of the years 1984 and 1985 are \$389.50 and \$413.90 respectively.

Notice is hereby given that calculations in accordance with the said section produce the following rates of compensation which are payable, on and from 1 July 1986 instead of the amounts specified in section 9 of the said Act, in the clauses under the heading "The Clauses Referred To".

	<i>The amount specified in "The Clauses Referred To" (wherever occurring)</i>	<i>The adjusted amount to operate from 1 July 1986</i>
	\$	\$
1 (a) (i)	33 160	64 221
	8 088	15 666
	7 566	14 653
	7 044	13 643
	6 523	12 632
	6 001	11 622
	5 479	10 611
	4 957	9 600
	4 435	8 588
	3 914	7 581
	3 392	6 569
	2 870	5 558
	2 348	4 546
	1 826	3 537
	1 826	3 537
1 (a) (ii)	33 160	64 221
1 (b) (i)	105	203
	30	57
	10	19
	155	302
	78	150
	135	261
1 (b) (iii)	36 960	71 581

*Workers Compensation Act 1958*

## NOTICE OF NEW BENEFIT RATES PAYABLE IN ACCORDANCE WITH SECTION 11

Whereas section 11 of the *Workers Compensation Act 1958* provides for rates of compensation for certain specified injuries to be set percentages of the maximum amount payable under Clause 1 (a) (ii) of "The Clauses Referred To" in section 9 of the Act, at the time of the injury.

And whereas the amounts specified in "The Clauses Referred To" in section 9, increase further, on and from 1 July 1986 by 6.26 per cent, in line with the formula prescribed in that section.

Notice is hereby given that calculations to determine the benefits payable under section 11 of the Act produce the following rates of compensation for injuries occurring on and from 1 July 1986.

<i>Type of Injury</i>	<i>The adjusted amount to operate from 1 July 1986</i>
	<b>\$</b>
Total loss of the sight of both eyes	64 221.00
Total loss of the sight of an only eye	64 221.00
Loss of both hands	64 221.00
Loss of both feet	64 221.00
Loss of hand and a foot	64 221.00
Total and incurable loss of mental powers involving inability to work	64 221.00
Total and incurable paralysis of the limbs or of mental powers	64 221.00
Total loss of the right arm or of the greater part of the right arm	51 376.80
Total loss of the left arm or of the greater part of the left arm	48 165.75
Total loss of the right hand or of five fingers of the right hand, or of the lower part of the right arm	44 954.70
Total loss of the same for the left hand and arm	41 743.65
Total loss of a leg	48 165.75
Total loss of a foot	41 743.65
Total loss of the lower part of the leg	44 954.70
Total loss of the sight of one eye, together with the serious diminution of the sight of the other eye	48 165.75
Total loss of hearing	41 743.65
Total loss of hearing in one ear	12 844.20
Total loss of sight in one eye	25 688.40
Loss of binocular vision	25 688.40
Total loss of the thumb of the right hand	19 266.30
Total loss of the thumb of the left hand	16 697.46
Total loss of the forefinger of the right hand	13 486.41
Total loss of the forefinger of the left hand	11 559.78
Total loss of two joints of the forefinger of the right hand	10 275.36
Total loss of two joints of the forefinger of the left hand	7 706.52
Total loss of a joint of the thumb	10 275.36
Total loss of the first joint of the forefinger of the right hand	6 422.10
Total loss of the first joint of the forefinger of the left hand	5 779.89
Total loss of the first joint of the middle or little or ring finger of either hand	3 853.26
Total loss of the middle finger of either hand	7 706.52
Total loss of the little or ring finger of either hand	7 064.31
Total loss of two joints of the middle finger of either hand	6 422.10
Total loss of two joints of the little or ring finger of either hand	5 779.89
Total loss of the great toe of either foot	14 128.62
Total loss of a joint of the great toe of either foot	6 422.10
Total loss of any other toe	3 853.26
Total loss of a joint of any other toe	1 284.42
Partial loss of the sight of both eyes or of an only eye—a determined percentage of	64 221.00
Partial loss of the sight of one eye—a determined percentage of	25 688.40
Partial loss of the hearing of both ears or of an only ear—a determined percentage of	41 743.65
Partial loss of the hearing of one ear—a determined percentage of	12 844.20
Two or more of the above injuries—maximum entitlement	64 221.00

*Private Agents Act 1966*

## NOTICE OF RECEIPT OF APPLICATIONS FOR LICENCES UNDER THE PROVISIONS OF THE PRIVATE AGENTS ACT 1966

The Clerk(s) of the Magistrates' Court(s) as listed hereunder hereby give notice that applications, as under, have been lodged for hearing by the said Court(s) on the date(s) specified.

Any person desiring to object to any of such applications must—

- (a) lodge with the respective Clerk of the Magistrates' Court a notice in the prescribed form of his objection and of the grounds thereof;
- (b) cause a copy of such notice to be served personally or by post upon the applicant at least three days before the hearing of the application; and
- (c) send or deliver—
  - (i) where the objection is not made by the officer in charge of the police district in which the Court is situated—a copy of the notice to such officer; and
  - (ii) where the objection is not made by the Registrar or Deputy Registrar—a copy to the Registrar.

<i>Full Name of Applicant*</i>	<i>Place of Abode of Applicant or Nominee</i>	<i>Name of Firm or Corporation</i>	<i>Address for Registration</i>	<i>Type of Licence</i>	<i>Date of Hearing</i>
<b>MAGISTRATES' COURT, BOX HILL</b>					
Karyotakis, George	2 Allara Ct, Donvale	G.M.A. Investigations and Process Servers	2 Allara Ct, Donvale	Process Server and Inquiry Agent	21.7.86
Dated at Box Hill, 27 June 1986 Clerk of the Magistrates' Court					
<b>MAGISTRATES' COURT, MOONEE PONDS</b>					
Carroll, Anthony John	83 Rachele Rd, East Keilor		29 Wonganella Dve, East Keilor	Watchman	5.8.86
Dated at Moonee Ponds, 1 July 1986 S. JANSON, Clerk of the Magistrates' Court					
<b>MAGISTRATES' COURT, BAIRNSDALE</b>					
Ainsworth, Kim John Charles	31 Mitchell St, Bairnsdale	Bairnsdale Town Security and Shutter Service	15 Wrex St, Paynesville	Watchman	8.7.86
Dated at Bairnsdale, 19 June 1986 D. R. SMITH, Clerk of the Magistrates' Court					
<b>MAGISTRATES' COURT, LILYDALE</b>					
Saunders, Shane Irvn	14 Carawa St, Mooroolbark		26 North Rd, Lilydale	Watchman	18.7.86
Dated at Lilydale, 20 June 1986 R. O'KEEFE, Clerk of the Magistrates' Court					
<b>MAGISTRATES' COURT, RINGWOOD</b>					
Kirkwood, Robert Stephen	13 Bronwyn St, Coldstream		14A Thornton Cres, Mitcham	Watchman	15.7.86
Dated at Ringwood, 20 June 1986 D. REES, Clerk of the Magistrates' Court					

\*Or in the case of a firm or corporation, of the Nominee

## PRIVATE AGENTS—continued

Full Name of Applicant*	Place of Abode of Applicant or Nominee	Name of Firm or Corporation	Address for Registration	Type of Licence	Date of Hearing
<b>MAGISTRATES' COURT, SUNSHINE</b>					
Holmes, Greg John	216 Heaths Rd, Hoppers Crossing	Metropolitan Security Services	2 McDonalds Rd, Brooklyn	Watchman	29.7.86
Reed, Gary Stephen	28 William St, Greensborough	" "	" "	"	"
Kermac, Robert Paul	21 Dendy St, Nth. Sunshine	" "	" "	"	"
Sekulovski, Bone	4 Syme Rd, St Albans	" "	" "	"	5.8.86
Dated at Sunshine, 2 July 1986 G. G. WILLIAMSON, Clerk of the Magistrates' Court					
<b>MAGISTRATES' COURT, NORTHCOTE</b>					
Allan, James	2 Darebin Crt. Coolaroo	Alun C. Dauncey	54 Wingrove St, Fairfield	Watchman	25.8.86
Anderson, Robert Stanley	8/108 Mitchell St, Brunswick	" "	" "	"	"
Pemberton, William Peter	43 Dunkeld St, Coolaroo	" "	" "	"	"
Dated at Northcote, 23 June 1986 R. J. MALONEY, Clerk of the Magistrates' Court					
<b>MAGISTRATES' COURT, NORTHCOTE</b>					
Skok, Danny	151/1 Raglan St, Preston	Alun Dauncey	54 Wingrove St, Fairfield	Watchman	18.8.86
Dated at Northcote, 20 June 1986 R. J. MALONEY, Clerk of the Magistrates' Court					
<b>MAGISTRATES' COURT, OAKLEIGH</b>					
Carver, Nemours Nickaus	1821 Dandenong Rd, Nth Clayton		447 Springvale Rd, Glen Waverley	Watchman	11.7.86
Dated at Oakleigh, 23 June 1986 W. BYRNE, Clerk of the Magistrates' Court					
<b>MAGISTRATES' COURT, BALLARAT</b>					
Milenkovic, Alexander	25 Little Clyde St, Ballarat	Ballarat Security Services	205 Richards St, Ballarat	Watchman	16.7.86
Dated at Ballarat, 23 June 1986 D. L. CROFT, Clerk of the Magistrates' Court					
<b>MAGISTRATES' COURT, CHELTENHAM</b>					
Egan, Nicholas	22 Orlando St, Hampton	TSM Security	11 Hoffman St, Cheltenham	Watchman	30.7.86
Dated at Cheltenham, 24 June 1986 W. WARD, Clerk of the Magistrates' Court					

\*Or in the case of a firm or corporation, of the Nominee



PRIVATE AGENTS—*continued*

Full Name of Applicant*	Place of Abode of Applicant or Nominee	Name of Firm or Corporation	Address for Registration	Type of Licence	Date of Hearing
MAGISTRATES' COURT, WODONGA					
Vaughan, Peter Bernard	8 Diamond Dve, Wodonga		28 Stephenson St, Richmond	Watchman	22.7.86
Dated at Wodonga, 27 June 1986 P. DODGSON, Clerk of the Magistrates' Court					
MAGISTRATES' COURT, WANGARATTA					
Cardwell, Peter Laurence	1 Bond Crt, Wangaratta		16 Floyd Ave, Wangaratta	Watchman	14.7.86
Dated at Wangaratta, 18 June 1986 K. W. LEWIS, Clerk of the Magistrates' Court					
MAGISTRATES' COURT, DROMANA					
Barr, William	13 Rosalie Ave, Dromana	Phillip John Ellis	4 Adina Pl, Mornington	Comm. Sub- Agent	21.7.86
Dated at Dromana, 16 June 1986 M. LEA, Clerk of the Magistrates' Court					
MAGISTRATES' COURT, TRARALGON					
Collins, Neil Raymond	19 Queens Pde, Traralgon	Globe Security Service Pty Ltd	10 Kay St, Traralgon	Watchman	7.8.86
Dated at Traralgon, 2 July 1986 T. A. GRANT, Clerk of the Magistrates' Court					
MAGISTRATES' COURT, BROADMEADOWS					
Falahey, William	2 Victory Pde, Ascot Vale		2 Victory Pde, Ascot Vale	Watchman	25.7.86
Dated at Broadmeadows, 23 June 1986 D. GEAR, Clerk of the Magistrates' Court					
MAGISTRATES' COURT, CAMBERWELL					
Hutchinson, Kaylene Joy	5/365 Victoria Rd, Thornbury		114 Winfield Rd, North Balwyn	Watchman	30.7.86
Dated at Camberwell, 26 June 1986 J. RISSTROM, Clerk of the Magistrates' Court					
MAGISTRATES' COURT, CAMBERWELL					
Jones, Andrew David	75 Dorset Rd, Croydon		1214 Toorak Rd, Hartwell	Watchman	30.7.86
O'Mara, Damian Francis	167 Mont Albert Rd, Canterbury		" "	" "	" "
Dated at Camberwell, 27 June 1986 J. RISSTROM, Clerk of the Magistrates' Court					
MAGISTRATES' COURT, WODONGA					
Daniels, John Anthony	F1/731 East St, Albury		634 Graham St, Port Melbourne	Watchman	22.7.86
Dated at Wodonga, 2 July 1986 P. G. DODGSON Clerk of the Magistrates' Court					

\*Or in the case of a firm or corporation, of the Nominee

## PRIVATE AGENTS—continued

Full Name of Applicant*	Place of Abode of Applicant or Nominee	Name of Firm or Corporation	Address for Registration	Type of Licence	Date of Hearing
MAGISTRATES' COURT, LILYDALE					
Bird, David James	L1-66 Castella St, Lilydale		17 Picadilly Crt, Kilsyth	Watchman	16.7.86
Dated at Lilydale, 16 June 1986 R. O'KEEFE, Clerk of the Magistrates' Court					
MAGISTRATES' COURT, MELBOURNE					
Akers, Douglas Howard	4 Valnere St, Footscray	T.N.T. Group 4	54 Racecourse Rd, North Melbourne	Watchman	9.7.86
Bentiuoglio, Pasquale	7 Thompson St, Avondale Heights	" "	" "	"	"
Soligon, Linda	6 Margaret St, Oak Park	Wormald Security	87 Racecourse Rd, North Melbourne	"	"
Dated at Melbourne, 13 June 1986 B. O'TOOLE, Clerk of the Magistrates' Court					
MAGISTRATES' COURT, SOUTH MELBOURNE					
Homann, John Reginald	2/10 Wrexham Rd, Windsor	York Security Group Pty Ltd	119 York St, South Melbourne	Watchman	18.7.86
Dated at South Melbourne, 16 June 1986 T. BEDOHAZY, Clerk of the Magistrates' Court					
MAGISTRATES' COURT, FRANKSTON					
Cowling, Simon	1 Lacenet Ave, Frankston North		1 Lacenet Ave, Frankston North	Inquiry Agent Individual	16.7.86
Dated at Frankston, 25 June 1986 J. T. FERGUSON, Clerk of the Magistrates' Court					
MAGISTRATES' COURT, MORNINGTON					
Goss, Malcolm Edward	3/14 Beatty Pde, Mornington	Penninsula Security Services	796 Nepean Highway, Mornington	Watchman	17.7.86
Dated at Mornington, 19 June 1986 M. LEA, Clerk of the Magistrates' Court					
MAGISTRATES' COURT, MOONEE PONDS					
Davies, Elizabeth Marie	14 The Avenue, Niddrie		14 The Avenue, Niddrie	Guard Agent Individual	21.7.86
Davies, Alan	" "		" "	"	"
" "	" "		" "	(Firm)	"
Adam, Abdallah Mustaffah	2-7 Trafford St, East Brunswick		21 Glencairn Ave, Coburg	Watchman	30.7.86
Gould, John Robert	F1, 2/13 Stock St, Coburg		29 Wonganella Dr, East Keilor	"	"
Dated at Moonee Ponds, 23 June 1986 S. JANSON, Clerk of the Magistrates' Court					

\*Or in the case of a firm or corporation, of the Nominee

Transport Act 1983

DECLARATION OF ROADS BY THE  
MINISTER FOR TRANSPORT

The Minister for Transport for the State of Victoria declares the roads or parts of roads or any deviations from or widenings of roads as described below—

State Highways

- 32/86 Declaration of the widening of the Goulburn Valley Highway in the Shire of Yea as shown hatched on plan numbered GP 15832B.
- 33/86 Declaration of the widening of the Glenelg Highway in the City of Hamilton as shown hatched on plans numbered GP 6348B and GP 6349B.
- 34/86 Declaration of the widening of the South Gippsland Highway in the Shire of Cranbourne as shown hatched on plans numbered GP 15872B, GP 16094B and GP 16095B.

Main Roads

- 35/86 Declaration of the widening of Badger Creek Road in the Shire of Healesville as shown hatched on plan numbered GP 15820B.
- 36/86 Declaration of the widening of the Myrtleford-Yackandandah Road in the Shire of Yackandandah as shown hatched on plans numbered GP 16535B and GP 16535D.
- 37/86 Declaration of the widening of the Doncaster-Mordialloc Road in the City of Waverley as shown hatched on plan numbered GP 14814B.
- 38/86 Declaration of the widenings of the Korumburra-Drouin Road in the Shire of Korumburra as shown hatched on plan numbered GP 16457B.

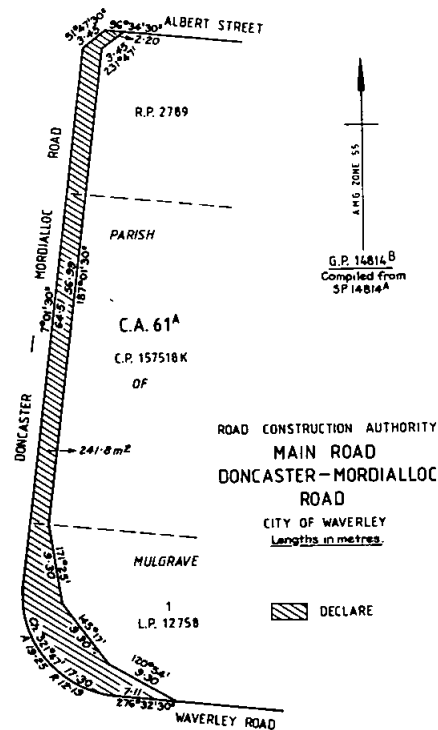
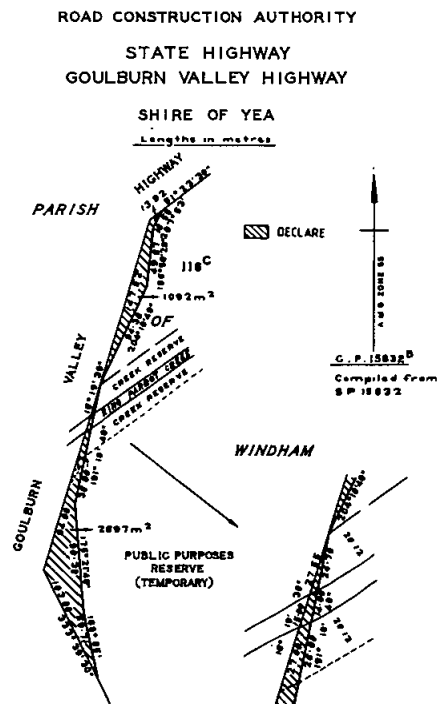

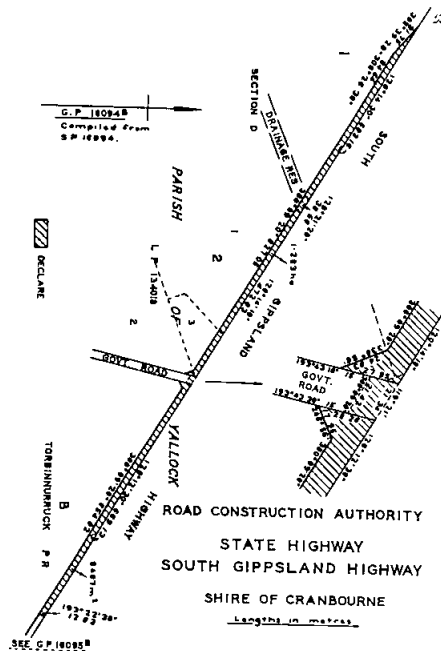
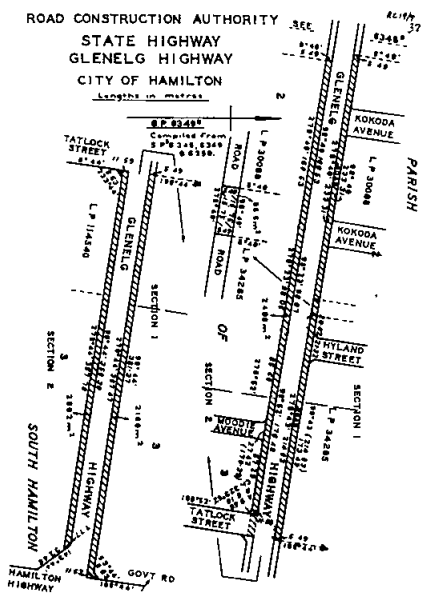
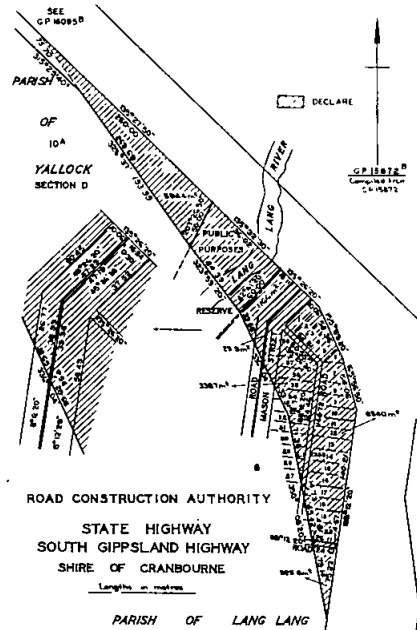
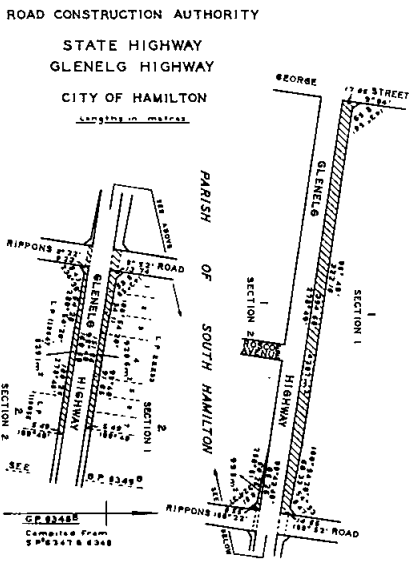

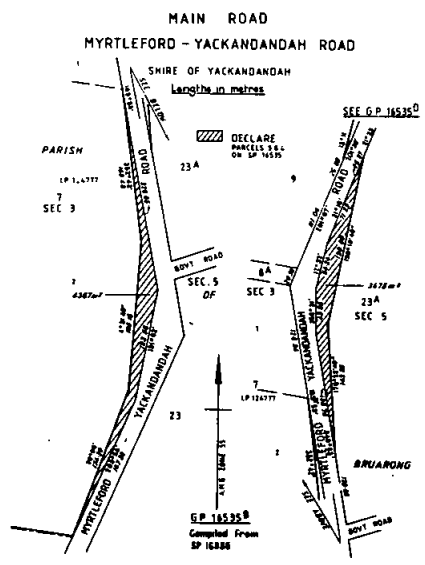
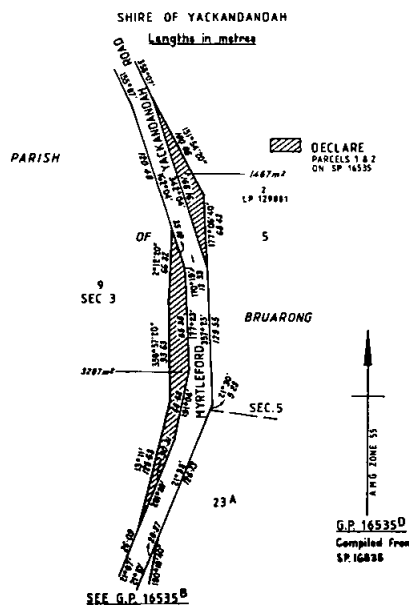
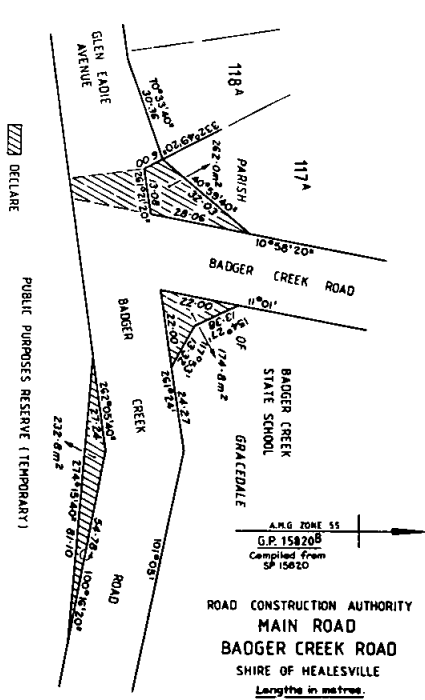
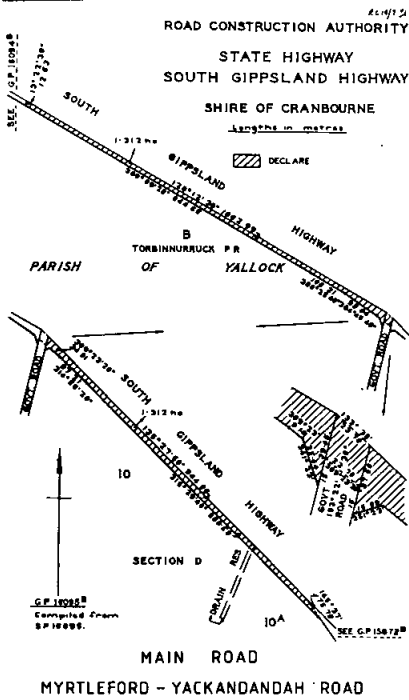

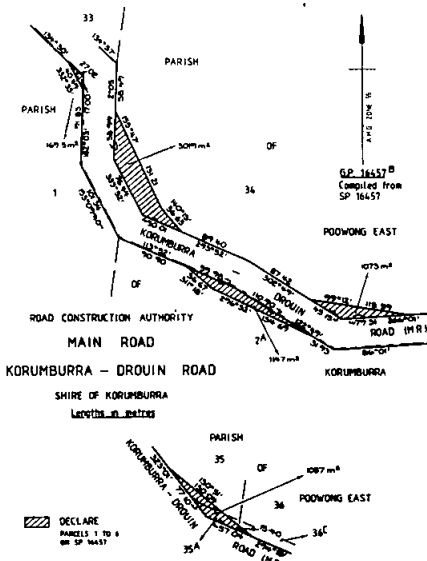

1 July 1986

T. W. ROPER  
Minister for Transport

**SHIRE OF PORTLAND**  
Road Deviation Order

Pursuant to the provisions of sections 522 and 526 of the *Local Government Act 1958*, as amended, the Council of the Shire of Portland hereby directs that the land in the Shire of Portland being Crown Allotment 23A and part Government Road, no Section, Parish of Dartmoor, County of Folett, which is shown hatched on the plan hereunder, which has been taken, purchased or acquired by it, shall be a public highway from and after the date of

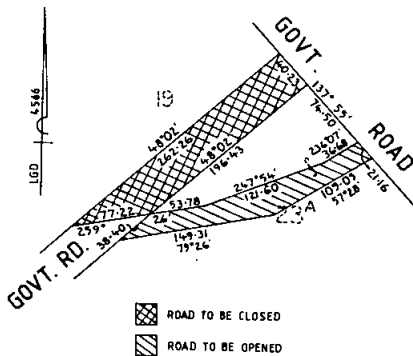

the publication of this Order in the *Government Gazette*, and declares that such land shall be a public highway in lieu of land in the said parish shown cross hatched on the said plan.

Dated 6 December 1985

The Common Seal of the President Councillors and Ratepayers of the Shire of Portland was hereunto affixed in the presence of—

E. V. GEE, President  
E. D. McERVALE, Councillor  
I. E. BENBOW, Secretary

Confirmed by the Governor in Council 1 July 1986—L. G. HOUSTON, Clerk of the Executive Council

**Local Government Department**  
**ORDER CONFIRMED—CITY OF BRUNSWICK**

I, James Lionel Simmonds, Her Majesty's Minister of the Crown for the time being administering the *Local Government Act 1958*, hereby confirm the Order hereinafter referred to in pursuance of section 514 of the said Act namely:

An Order of the Council of the City of Brunswick made on 5 May 1986, directing the compulsory taking of that part of the land described in Certificate of Title Volume 2860 Folio 924 which was excised therefrom by an Order of the Commissioner of Titles dated 28 August 1907 (No. 9947) for the purpose of providing a place of public resort and recreation.

Dated 23 June 1986

J. L. SIMMONDS  
Minister for Local Government

**MELBOURNE AND METROPOLITAN BOARD OF WORKS**  
General Notice

The Melbourne and Metropolitan Board of Works having made provision for carrying off the sewage of each and every property which or any part of which is situate in the Sewerage Areas hereinafter described doth hereby declare that on and after the 14 July 1986 each and every property so situate shall be deemed to be a sewered property within the meaning of the *Melbourne and Metropolitan Board of Works Act 1958*.

The Sewerage Areas hereinbefore referred to are:  
Sewerage Area No. 5175

City of Knox—This area comprises all lots in Schneider Street and Opie Street, lots 88 to 81 Moore Street, lots 1, 2 and 49 to 57 Rona Street, lots 73 to 65 and 82 to 88 Birdwood Avenue, lots 10 to 8, part lot 11 and lots 12 to 14 Hatherly Grove, lots 6, 7 and 59 to 61 Kia Ora Parade, lots 55 to 58 Clematis Avenue.

## Sewerage Area No. 5320

City of Croydon—This area comprises all lots in Standen Court, lots 51 to 58, 66 to 68 and 102 to 87 Chittingstone Drive, lots 86 to 84 Sandhurst Grove.

## Sewerage Area No. 5532

Shire of Lillydale—This area comprises a Reserve and a further Reserve Montrose Road, lot 4, part lot 3, part lot 2, lots 1, 2, 1 to 3, 4 to 6 and 2 Cambridge Road, lots 1 to 6, 7 to 9, 2, 1 and 12 to 16 Greenhills Avenue, lots 1, 2 a further lot 2 and a further lot 2, lots 1, 2 and a further lot 2, part lots 5, 6 a further part lot 6 and part lot 3 Trevallyn Road, lots 21 to 23 Henry Street, portion of a Melbourne and Metropolitan Board of Works Pipe Track abutting Montrose Road, Trevallyn Road and Cambridge Road.

## Sewerage Area No. 5489

City of Springvale—This area comprises lots 33 and 1 Centre Dandenong Road.

## Sewerage Area No. 5521

Shire of Cranbourne—This area comprises all lots in Reeves Court, Chester Drive, Owens Court, Conway Court and Denver Court, lots 1 to 11 and 53 to 63 Ivan Crescent, lots 1, 64 and 73 to 83 Hallam Road, lots 199, 198, 72 to 64, 63 to 45, 32, 31, 18 to 16, a Reserve, 192 to 186, 181 to 177, 107 to 104, 96 to 94, 85 and 84 Cairns Road, lots 108, 175 and 176 Hawking Avenue, lot 193 Campbell Drive, lots 43 to 41 and 44 Horton Drive.

## Sewerage Area No. 5540

Shire of Cranbourne—This area comprises all lots in Dulnain Close, lots 526 to 524, 514 to 506, 505 to 502, 492 and 491 Willow Drive, lot 515 Adley Place, lot 490, an Electricity Reserve, lots 489 to 474, 293 to 305 and 405 Oaktree Drive, lots 404 and 403 Millswyn Avenue.

## Sewerage Area No. 5562

City of Doncaster and Templestowe—This area comprises all lots in Gina Court, Simone Crescent and Leanne Court, lots 31 to 26 a Municipal Reserve, lots 25 to 22, 19 to 17, 5 to 1 and 32 to 45 Deep Creek Drive, a Tree Reserve abutting Andersons Creek Road, Heidelberg—Warrandyte Road and Deep Creek Road.

## Sewerage Area No. 5574

City of Croydon—This area comprises all lots in Tatiara Avenue, Borola Court and Mulawa Street, lots 8, 7, 3, 2 and 1 Rustic Rise, lots 27 and 26 Alice Street, lots 5 to 31 and 1 Oaktree Road, lots 2, 1 and 2 to 4 Warriën Road.

## Sewerage Area No. 5589

City of Ringwood—This area comprises lots A, B and C Plymouth Road.

## Sewerage Area No. 5598

City of Knox—This area comprises lots 29, 30, 33, 34, 5 to 1, 41, 42 and 43 Forest Road, lots 2, 1 and a further lot 1 Burston Road, lots 36, 32 and 31 Hansen Road.

## Sewerage Area No. 5590

City of Springvale—This area comprises lot 2 Centre Dandenong Road, a portion of the MMBW South Eastern Trunk Sewer Pipe Track abutting Centre Dandenong Road.

## Sewerage Area No. 5594

City of Berwick—This area comprises lots 66 to 61 Cowper Rise, lots 60 to 58 and 67 to 72 Royston Avenue, a portion of a Reserve Harkaway Road.

## Sewerage Area No. 5595

City of Berwick—This area comprises lots 33 to 40 a Reserve, lots 41 to 45, 46, 47 and 48 to 57 Bournevale Drive.

## Sewerage Area No. 5597

Shire of Cranbourne—This area comprises lot 69 Kerrison Drive.

## Sewerage Area No. 5599

City of Knox—This area comprises all lots in Gath Court and Trevena Close, lots 127, 126, 103 to 99 and 93 to 86 Karoo Road.

## Sewerage Area No. 5601

City of Croydon—This area comprises all lots in Penshurst Place, lots 1 to 4 and 5 to 8 Brysons Road, lots 14 to 19, 20 and 21 Tambridge Way, lots 45 to 49, 1 and 13 Chittingstone Drive, lots 9 to 12 Sandhurst Grove.

## Sewerage Area No. 5605

City of Knox—This area comprises lots 21 to 17 Burwood Highway, lots 16 to 13 and 12 to 9 Hooker Road, lots 8 to 1 Corbert Street and a Reserve abutting Hooker Road and Corbert Street.

## Sewerage Area No. 5607

City of Knox—This area comprises all lots in Beckbury Court and Louise Court, lots 201 to 197, an Electricity Reserve, lots 196, 195, 185, 184, 31 to 29, 28 and 27 Sullivan Avenue, lot 25 Bethelle Court.

## Sewerage Area No. 5602

Shire of Werribee—This area comprises all lots in Elliot Court, lots 2614 to 2605 Derrimut Road, lots 2602 to 2604, 2491 to 2510, 2512, 2404, 2441, 2442, 2476, 2477, a Municipal Reserve and lots 2478 to 2484 Cameron Drive, lots 2489, 2490, 2548, 2549, 2593 to 2572, 2523, 2522, 2642 to 2639, 2638 to 2632, a Reserve, lots 2631 to 2627, 2626 to 2620 and 2596 to 2601 Bourke Crescent, lots 2547 to 2531, a Municipal Reserve, lots 2524 and 2571 to 2550 Hunter Avenue, lot 2403 Mossfiel Drive.

## Sewerage Area No. 5271

City of Keilor—This area comprises lots 1 to 12 and 55 to 57 Brentwood Drive.

## Sewerage Area No. 5617

City of Keilor—This area comprises all lots in Singer Avenue and Rover Court, lots 431, 430, 678 to 689, 670 to 673, 808 to 804, 504, 494 to 491, an Electricity Reserve and a Municipal Reserve Willys Avenue, lots 429 and 428 Morris Drive, lots 863 to 865, 887 to 897, 908 to 917, 878 to 886 and an

Electricity Reserve Minerva Crescent, lots 898 to 901, 906 and 907 Vincent Close, lot 919 Darracq Drive, lots 866 and 862 Tarrant Court, portion of Tree Reserves abutting Sunshine Avenue and Singer Avenue, a Municipal Reserve abutting Minerva Crescent, Singer Avenue, Winton Court and Willys Avenue.

Sewerage Area No. 5608

City of Chelsea—This area comprises lots 417 to 415 Gladesville Boulevard, lots 389 to 385 Curlew Point Drive.

Sewerage Area No. 5612

City of Keilor—This area comprises lots 62 to 79, 81 to 85, a Reserve, lots 86, 87, 103 to 105 and 120 to 127 Kinterbury Drive, lots 119 to 115 and 111 to 106 Balmoral Close, lots 102 to 96 and 95 to 88 Wyvern Walk, lot 80 Tremaine Avenue.

Sewerage Area No. 5625

Shire of Cranbourne—This area comprises all lots in Pride Court, Cline Court, Riley Place and Wynette Close, lots 182, 183, 166 to 169, 184 and 185 Cash Close, lot 153 Campbell Drive, lots 152, 160 to 165, 173, 174, 133 to 135 and 141 to 151 Hawking Avenue, lots 109 to 113 and 129 to 132 Robbins Way, a Reserve abutting Cline Court and Cash Close, a Reserve abutting Cash Close and Pride Court, a Reserve abutting Pride Court and Campbell Drive.

Sewerage Area No. 5636

City of Oakleigh—This area comprises lots 1 and 2 Heatherton Road.

Sewerage Area No. 5637

City of Moorabbin—This area comprises lot 9 Hannah Street.

Sewerage Area No. 5626

City of Knox—This area comprises lots 36 to 25, 142, 45, 2, 1 and 42 to 37 McIver Street, lots 50 to 47, 1, 2, 185, 1 and 62 to 51 Roberts Street, lot 1 Blackwood Park Road.

Sewerage Area No. 5641

Shire of Cranbourne—This area comprises lots 58 to 62, a Reserve, lots 63 to 72, a Reserve, lots 43, 44, 45 to 53, a Reserve and lots 54 to 57 Warana Drive.

Sewerage Area No. 5648

City of Berwick—This area comprises lots 15 to 23 and 70 to 86 Strathavan Drive.

Sewerage Area No. 8001

City of Waverley—This area comprises all lots in Geraldine Close and Tanya Place, lots 905 to 914 and 945 to 949 Garnett Road.

Dated 8 July 1986

By order of the Board

H. G. FORD  
Director of Administration and Services  
625 Little Collins Street, Melbourne

*Co-operation Act 1981*

GUTHRIE STREET SHEPPARTON  
CO-OPERATIVE LIMITED

THIRD RINGWOOD (EAST) BOY SCOUT  
CO-OPERATIVE LIMITED

Notice is hereby given in pursuance of section 192 (8) of the *Co-operation Act 1981* and section 459 (2) of the Companies (Victoria) Code that, at the expiration of three months from the date hereof, the names of the aforementioned societies will, unless cause is shown to the contrary, be struck off the register and the societies will be dissolved.

Dated at Melbourne 24 June 1986

B. F. ISWORTH

Acting Registrar of Co-operative Societies

*Co-operation Act 1981*

NOTICE OF TRANSFER OF REGISTRATION

Redlight Monitoring Service Co-operative Limited

Notice is given that the above co-operative has, as from 5 March 1986, transferred its registration to the *Associations Incorporation Act 1981* and is now incorporated under that Act, under the name of Redlight Monitoring Emergency Service Australia Incorporated.

Accordingly, the co-operative has been struck from the Register of Co-operative Societies as from 5 March 1986.

B. F. ISWORTH

Acting Registrar of Co-operative Societies

*Co-operation Act 1981*

NOTICE OF DISSOLUTION OF SOCIETIES

Ferntree Gully and Districts School Camp  
Co-operative Limited

Mornington Rental Housing Co-operative Ltd

Oberon Primary School Co-operative Limited

Portarlington Fishermen's Co-operative Society  
Limited

Port Melbourne & South Melbourne Turkish  
Community Co-operative Limited

Rosanna Tennis Club Co-operative Limited

Seventh Glen Waverley Boy Scout Co-operative  
Limited

Shoe String Theatre Co-operative Limited

Small Holders Co-operative Limited

Templestowe Pre-school Co-operative Limited

3rd Nunawading South Boy Scout Co-operative  
Limited

Thomastown High Co-operative Limited

Watsonia Heights Primary School Co-operative  
Limited



Notice is hereby given that I have this day registered the dissolution of the abovenamed societies and cancelled their registration under the abovenamed Act.

Dated at Melbourne 12 June 1986

B. F. ISWORTH  
Acting Registrar of Co-operative Societies

*Co-operation Act 1981, Section 84B*  
NOTICE OF MERGER OF SOCIETIES

Notice is hereby given that, pursuant to the provisions of the *Co-operation Act 1981*, Waverley Credit Union Co-operative Limited and Syndal Co-operative Credit Society Limited were merged into one society under the name of Waverley Credit Union Co-operative Limited on 13 June 1986.

Dated at Melbourne 30 June 1986

B. F. ISWORTH  
Acting Registrar of Co-operative Societies

*Co-operation Act 1981*  
CHANGE OF NAME OF A SOCIETY

Notice is hereby given that V.S.L. Ski Club Co-operative Limited which was incorporated as a Community Advancement Society under the abovenamed Act on 28 October 1976, has registered a change of its name and is now incorporated under the name of Veteran Skiers League (Mt. Buller) Co-operative Ltd. under the said Act.

Dated at Melbourne 16 June 1986

D. F. HENRY  
Acting Deputy Registrar of Co-operative Societies

*Transport Act 1983*  
ROAD TRAFFIC AUTHORITY

Commercial Passenger Vehicle Applications

Notice is hereby given that the following applications will be considered by the Road Traffic Authority on 29 July 1986.

Notice of any objections should be forwarded to reach the Manager, Vehicle Licensing Branch or any Regional Office of the Road Traffic Authority not later than 23 July 1986.

It will not be necessary for interested parties to appear on the hearing date specified, unless advised in writing by the Authority.

Notification of the date for consideration of applications which are objected to and which require determination by the Road Transport Licensing Tribunal will be published by further notice in this Gazette.

Harrison, M. N. and K. M., Churchill. Application for variation of the conditions of licence CT 726 which authorizes taxi operations from Morwell, Traralgon and Churchill under radio control from the depot of Morwell Taxis to change the depot and

operate under radio control from Churchill Taxi Cab Service, Switchback Road, Churchill.

Hollins, J., Epping. Application to license one commercial passenger vehicle with seating capacity for 41 passengers to operate for the carriage of various school, community, youth, church and club groups attending the Leisure City Sports Centre located at Miller Street, Epping between the point of pick-up within and including an area bounded by the Hume Highway, Bell Street, Rosanna, Greensborough, Diamond Creek and Hurstbridge Roads and the Kinglake, Glenvale to Wallan East Roads, and the sports centre.

*Timetable:* As and when required.

*Fares:* Transport costs included in admission fee to centre.

Long, K. F., Rosanna. Application to license one commercial passenger vehicle in respect of a 1959 Austin Limousine with seating capacity for 7 passengers to operate as a special purpose vehicle from 47 Mountain View Parade, Rosanna for the carriage of passengers for wedding parties within the Melbourne metropolitan area.

Malcolm, R. A. and E. F., Churchill. Application for variation of the conditions of licence CT 667, which authorizes taxi operations from Morwell, Traralgon and Churchill under radio control from the depot of Morwell Taxis to change the depot and operate under radio control from Churchill Taxi Cab Service, Switchback Road, Churchill.

Marvilla, C. and R. and S. F. and G. A., Myrtleford. Application for variation of the conditions of licence TS 1563 which authorizes the Carboor Upper to Markwood Ministry of Education contract service to operate under charter conditions from within a 20 km pick-up radius of Markwood. *Note:* (i) The licensed vehicle holds a 2-star rating for charter purposes. (ii) The rights sought have previously been authorized under permit. (iii) Notice of this application replaces a notice which appeared in the *Victoria Government Gazette* No. 17, dated 19 March 1986.

Misuraca Vintage Fiat Wedding Cars Pty. Ltd., Coburg. Application to license three commercial passenger vehicles in respect of 1919-1925 Fiat tourers, two with seating capacity for 4 passengers and one with seating capacity for 1 passenger to operate as special purpose vehicles from 39 Kendall Street, Coburg for the carriage of passengers for wedding parties and special occasions. *Note:* (i) Notice of this application replaces a notice which appeared in the *Victoria Government Gazette* No. 44, dated 4 June 1986. (ii) Previous objections to the granting of this application are invalid and interested parties are advised that a new notice of objection must be submitted.

Muir, G. M. and D. V., Pty. Ltd., Rushworth. Application to license one commercial passenger vehicle with seating capacity for 18 passengers to

operate under charter conditions from within a 20 km pick-up radius of the Post Office at Rushworth.  
*Note:* The vehicle to be licensed holds a 2-star rating for charter purposes.

O'Connor, K. M., L. and V. C., Bairnsdale. Application to license one commercial passenger vehicle with seating capacity for 15 passengers to operate as a touring omnibus on the Schedule of Tours currently authorized by the conditions of licences CO 775 and CO 1241 in the name of the applicants. *Note:* (i) No charter rights are sought in this application. (ii) This application is lodged subject to the cancellation of a TO licence granted by the Road Transport Licensing Tribunal in 1984 subject to the condition that a vehicle with large seating capacity be provided.

O'Connor, K. M., L. and V. C., Bairnsdale. Application for variation of the conditions of licences CO 775 and CO 1241 which authorize various route services, tours and charter, to delete the existing fare schedules for tours and instead charge fares as approved by the Authority from time to time.

O'Connor, K. M., L. and V. C., and Dykes, E. C., Bairnsdale. Application for variation of the conditions of licence CC 43 which authorizes various tours, route services and charter, to delete existing fare schedule for tours and instead charge fares as approved by the Authority from time to time.

Dated 9 July 1986

F. B. LINDSAY  
 Manager  
 Regulation

*Transport Act 1983*

Transport (Road Construction Authority Election of Members) Regulations 1983

NOTICE OF ELECTION

I, Thomas William Roper, Minister for Transport, hereby give notice pursuant to Regulation 7 of the Transport (Road Construction Authority Election of Members) Regulations 1983 of the election of one person as a member of the Road Construction Authority as follows:

*Nomination Day:* 25 July 1986.

*Returning Officer:* Kevin Campbell Findlay.

*Place for Receipt of Nominations:* 14th Level, Transport House, 589 Collins Street, Melbourne 3000.

*Polling Day:* 28 August 1986.

The person elected shall hold office for the period (not exceeding five years) that is determined by the Governor in Council.

TOM ROPER  
 Minister for Transport

I hereby give notice that on 24 June 1986, the Public Trustee filed Elections to Administer the following deceased persons' estates in accordance with section 17 of the *Public Trustee Act 1958*:

Bradley, Leslie Arthur Harry, also known as Leslie Harry Arthur Bradley and William Leslie Bradley, late of 38 Laurie Street, Newport, storeman and packer, died 12 June 1984.

Hogan, Leonard, late of 13 Clarinda Street, South Caulfield, pensioner, died 4 May 1986.

Mountjoy, Myra Gladys, formerly of Old Colonists Association of Victoria, The Homes, 44 Leith Park, Eltham North, but late of St Heliers Nursing Home, 2 Canterbury Road, Camberwell, pensioner, died 15 February 1986.

White, Neil Joseph, late of Ararat, pensioner, died 6 March 1986.

Dated 2 July 1986

W. J. KILPATRICK  
 Public Trustee

Creditors, next of kin, and others having claims against the estate of any of the under-mentioned deceased persons are required to send particulars of their claims to the Public Trustee, 168 Exhibition Street, Melbourne, Vic. 3000, the personal representative, on or before 11 September 1986 after which date the Public Trustee may convey or distribute the assets having regard only to the claims of which the Public Trustee then has notice:

Bradley, Leslie Arthur Harry, also known as Leslie Harry Arthur Bradley and William Leslie Bradley, late of 38 Laurie Street, Newport, storeman and packer, died 12 June 1984.

Hogan, Leonard, late of 13 Clarinda Street, South Caulfield, pensioner, died 4 May 1986.

Lawrence, Alfred Oscar Platt, formerly of 14 Crellin Grove, Camberwell, but late of Surrey Hills Nursing Home, 18 Florence Road, Surrey Hills, retired, died 15 March 1986.

Mountjoy, Myra Gladys, formerly of Old Colonists Association of Victoria, The Homes, 44 Leith Park, Eltham North, but late of St Heliers Nursing Home, 2 Canterbury Road, Camberwell, pensioner, died 15 February 1986.

Siuta, Stanislaw, also known as Stan Siuta, late of 122 Hope Street, Geelong West, driver, died 16 April 1986.

Way, Esther May, formerly of Flat 2, 2 Yarra Street, Hawthorn, but late of Croydon Park Nursing Home, 18-22 Hyton Crescent, Croydon, widow, died 23 March 1986.

White, Neil Joseph, late of Ararat, pensioner, died 6 March 1986.

Melbourne, 2 July 1986

W. J. KILPATRICK  
 Public Trustee

*Police Offences Act 1958, No. 6337*

## DIVISION 1A—STATE CLASSIFICATION OF PUBLICATIONS BOARD

Take note that the State Classification of Publications Board has classified the following publications in accordance with the provisions of section 180H (1) of the *Police Offences Act 1958*.

Each publication shall be subject to the following restrictions:

- (a) It shall not be offered for sale, sold or delivered to any person under the age of 18 years;
- (b) It shall not be made available for inspection or perusal by any person under the age of 18 years;
- (c) It shall not be exhibited or displayed in any place to which persons under the age of 18 years have access or so that it is visible from any such place.

<i>Title</i>	<i>Distributor</i>
Adult Video—Swank Gold Press—Vol. 4, No. 5 August/September 1986	Gordon and Gotch Ltd.
Live—September 1986—Vol. 6, No. 4	Gordon and Gotch Ltd.
Velvet Special No. 12—Three-Way Lovers	Gordon and Gotch Ltd.

R. V. DOOLEY  
Acting Secretary

State Classification of Publications Board

*Police Offences Act 1958, No. 6337*

## DIVISION 1A—STATE CLASSIFICATION OF PUBLICATIONS BOARD

Take note that the State Classification of Publications Board has classified the following publications in accordance with the provisions of section 180H (1) of the *Police Offences Act 1958*.

Each publication shall be subject to the following restrictions:

- (a) It shall not be offered for sale, sold or delivered to any person under the age of 18 years;
- (b) It shall not be made available for inspection or perusal by any person under the age of 18 years.

<i>Title</i>	<i>Distributor</i>
Australian Penthouse—August 1986—Vol. 7, No. 8	Gordon and Gotch Ltd.
Fiesta—Vol. 20, No. 7	Gordon and Gotch Ltd.
Razzle—Vol. 4, No. 13	Gordon and Gotch Ltd.

R. V. DOOLEY  
Acting Secretary

State Classification of Publications Board

## CONTRACTS ACCEPTED—(Series 1985-86)

## PUBLIC WORKS

Bulla Shire—Water reticulation, Sunbury Caloora Training Centre, \$100 000.00—Sunbury Waterworks Trust, Sunbury.

Melbourne City—Supply and installation of communication system, Melbourne, 376 Russell St. (Police Complex), \$93 529.00—Aero Data Systems Pty. Ltd., Essendon.

Melbourne City—Fit out works, Melbourne World Trade Centre (Tourism), \$452 000.00—Port of Melbourne Authority, Melbourne.

Moorabbin City—Alterations and additions to police station, Cheltenham Police Station, \$718 554.00—J. H. & A. G. & J. J. Lohman, Bayswater.

Northcote City—Upgrade staff admin. and library, Fairfield Primary School, \$418 351.00—R. J. & H. J. Dowsett, Keilor East.

Nunawading City—External cyclic maintenance, Burwood Heights High School, \$57 300.00—Pilgrim Painting & Renovations, Footscray.

Springvale City—Construction/staff/admin. upgrade, Noble Park Technical College, \$321 393.00—E. & R. Roberts Pty. Ltd, Dandenong North.

Upper Yarra Shire—Construction/master plan and Stage 1, Millgrove Primary School, \$763 605.00—Van Driel (Aust.) Pty. Ltd., Caulfield. Dated 3 July 1986

D. J. LITTLE  
Director-General of Public Works

## CONTRACTS ACCEPTED—(Series 1985-86)

## PUBLIC WORKS

South Central Metropolitan—Oil burners, original \$12 070.00, extras \$47 247.05—\$59 317.05—S. & R. Airconditioning & Electrical.

D. J. LITTLE  
Director-General of Public Works

Public Works Department  
Melbourne, 4 July 1986

## Police Regulation Act, Section 122

## SALE OF UNCLAIMED MOTOR VEHICLE

An owner is required for a blue 1975 model Holden Statesman sedan previous Registration No. IDN-721, engine No. QT601565.

The vehicle came into possession of Police on 4 April 1984 and if not claimed, will be sold by public auction at the Heidelberg Police Station, Jika Street, Heidelberg on Wednesday, 6 August 1986 at 10.00 a.m.

S. I. MILLER  
Chief Commissioner of Police

*Town and Country Planning Act 1961*  
SHIRE OF KILMORE PLANNING SCHEME  
1973

Amendment No. 59, 1985  
Notice of Approval

In pursuance of the powers conferred by the *Town and Country Planning Act 1961*, the Governor in Council on 8 July 1986 approved the abovementioned scheme in respect of the municipal district of the Shire of Kilmore and for which the Council of the Shire of Kilmore is the Responsible Authority.

The scheme comes into operation on the date this Notice is published in the *Government Gazette*.

The scheme includes the rezoning of approximately 60 hectares of land located north of the existing Wallan Township, from Rural A2 to Residential Development.

A copy of the documents may be inspected free of charge, during office hours, at the office of the Ministry for Planning and Environment, The Olderfleet Buildings, 477 Collins Street, Melbourne, and at the office of the Responsible Authority, the Shire of Kilmore, Civic Centre, Kilmore.

DAVID YENCKEN  
Secretary for Planning and Environment

*Public Records Act 1973* (Section 12)  
LOCAL GOVERNMENT RECORDS:  
GENERAL DISPOSAL SCHEDULE PROS 84/25  
Variation of Standard

In accordance with section 12 of the *Public Records Act 1973*, I hereby vary the standard applying to the functional and housekeeping records of local government issued as Public Record Office Standard Pros 84/25 on 24 May 1985, by suspending so much of the standard as permits the destruction of any records identified under Class 7.0.0. (Health) in the Schedule or of any record created prior to 1940 without the authorization of Keeper of Public Records, and this variation shall have effect from the date of issue of this variation until 31 December 1986.

C. HURLEY  
Keeper of Public Records

Date of issue: 27 June 1986

Public Record Office Standard: Pro 84/25

ASSOCIATIONS INCORPORATION ACT 1981

Notice is hereby given that in pursuance of sub-section 10 (4) of the *Associations Incorporation Act 1981* a certificate of incorporation was granted to Festival Theatre Company on 10 June 1986.

JOHN B. KING  
Registrar of Incorporated Associations

DECLARATION OF AUTHORITY UNDER  
SECTION 26 OF THE FREEDOM OF  
INFORMATION ACT 1982

I, Hans Eisen, Director-General of Industry, Technology and Resources, hereby authorize the officers listed below pursuant to section 26 of the *Freedom of Information Act 1982*, to make decisions on behalf of the Department that are required to be made in order to comply with and give effect to the provisions of the *Freedom of Information Act 1982*, in respect of requests made to the Department of Industry, Technology and Resources.

William Cushing, Deputy Director-General.

Bryan Williams, Group Manager, Corporate and Communication Services.

Dated 11 May 1986

HANS EISEN  
Director-General  
Industry, Technology and Resources

*Electric Light and Power Act 1958*

ORDER GRANTED BY THE GOVERNOR IN  
COUNCIL

It is hereby notified that an Order (No. 392) has been granted by His Excellency the Governor in Council under section 10 of the *Electric Light and Power Act 1958* (No. 624) to the Shire President, Councillors and Ratepayers of the Shire of Omeo enabling the supply of electricity to the Dinner Plain Alpine Village.

R. FORDHAM  
Minister for Industry, Technology and Resources

*Education Act 1958*

NOTICE OF THE MAKING OF AN ORDER  
UNDER SECTION 13 (4) OF THE ACT

Pursuant to section 13 of the *Education Act 1958* I hereby give notice that Orders of the Governor in Council were made on 1 July 1986 under sub-section (4) of the said Act amending certain provisions relating to the State School Councils listed below—

1081 Dargo Primary  
1712 Pyramid Hill H.E.S.  
2129 Ripplebrook Primary  
2135 Clear Lake Primary  
2725 Steel's Creek Primary  
2866 Barwon Downs Primary  
4834 Ewing House School for Deaf Children

I. R. CATHIE  
Minister of Education

## APPOINTMENTS

### APPOINTMENTS

His Excellency the Governor of the State of Victoria, by and with the advice of the Executive Council thereof, by order made on 1 July 1986 has been pleased to make the under-mentioned appointments, viz.:

#### Department of Health

#### *Members of the Committee of Management of Hospitals*

John Lindsay O'BREE

Rochester and District War Memorial Hospital, 30 September 1988,

Julie Ann JONES

Koroit and District Memorial Hospital, 30 September 1987,

Colin Alexander PURVIS

Yea and District Memorial Hospital, 30 September 1987,

Suzanne Janice FLEMING

Maldon Hospital, 30 September 1986,

Anthony GODFREY

Waranga Memorial Hospital, 30 September 1986. to be members of the Committee of Management of the abovementioned hospitals pursuant to the provisions of section 63H (2) of the *Hospitals and Charities Act 1958* for the period of office expiring on the dates indicated.

L. G. HOUSTON

Clerk of the Executive Council

At the Executive Council Chamber  
Melbourne, 1 July 1986

## ORDERS IN COUNCIL

### GEELONG WATERWORKS AND SEWERAGE ACT 1958, No. 6263

*At the Executive Council Chamber, Melbourne, the  
eighteenth day of March 1986*

#### PRESENT:

His Excellency the Governor of Victoria

Mrs Hogg                      |                      Mr McCutcheon  
Mr White                      |

His Excellency the Governor of the State of Victoria, by and with the advice of the Executive Council thereof, and pursuant to the provisions of and for the purposes of the abovementioned Act, doth hereby consent to the Geelong and District Water Board borrowing an amount not exceeding One Million Dollars (\$1 000 000).

And the Honourable Robert Allen Jolly, Her Majesty's Treasurer for the State of Victoria, shall give the necessary directions herein accordingly.

L. G. HOUSTON  
Clerk of the Executive Council

### GEELONG WATERWORKS AND SEWERAGE ACT 1958, No. 6263

*At the Executive Council Chamber, Melbourne, the  
eighth day of October 1985*

#### PRESENT:

His Excellency the Lieutenant-Governor  
of Victoria

Mrs Kirner                      |                      Mr Mathews

His Excellency the Lieutenant-Governor of the State of Victoria, by and with the advice of the Executive Council thereof, and pursuant to the provisions of and for the purposes of the abovementioned Act, doth hereby consent to the Geelong and District Water Board reborrowing of an amount not exceeding Four hundred and fifty thousand dollars (\$450 000).

And the Honourable Robert Allen Jolly, Her Majesty's Treasurer for the State of Victoria, shall give the necessary directions herein accordingly.

L. G. HOUSTON  
Clerk of the Executive Council

### COUNTRY RACECOURSE BOOKMAKERS REGULATIONS

*At the Executive Council Chamber, Melbourne, the  
first day of July 1986*

#### PRESENT:

His Excellency the Governor of Victoria

Mr Kennan                      |                      Mr McCutcheon  
Mr Roper                      |

In pursuance of the powers conferred by the *Racing Act 1958* and all other powers him thereunto enabling, His Excellency the Governor of the State of Victoria, by and with the advice of the Executive Council of the said State, hereby approves of the committee or other managing body of the clubs specified in the Schedule hereto making the following Regulation (that is to say):

Regulation 6 of the Regulations relating to Bookmakers and Bookmakers' Clerks made pursuant to section 5 of the *Racing Act 1958* is hereby rescinded and the following is substituted:

6. (a) The fee (hereinafter called "licensed betting fee") payable for permission to carry on the vocation of a bookmaker at a race meeting conducted by the said club on the said racecourse shall be in accordance with the following:

- (i) A licensed betting fee not exceeding \$32 for any picnic race-meeting;
- (ii) A licensed betting fee not exceeding \$49 for any licensed race-meeting held on a Saturday or Public Holiday;
- (iii) A licensed betting fee not exceeding \$57 for any other licensed race-meeting.
- (b) Wherever in accordance with plans submitted by the club and approved by the Governor in Council, there is provision for Rails Bookmakers applicants desiring to carry on as Rails Bookmakers shall in addition to the licensed betting fee (hereinafter called "rails fee") in accordance with the following:
- (i) A rails fee not exceeding \$64 for any picnic race-meeting;
- (ii) A rails fee not exceeding \$98 for any licensed race-meeting held on a Saturday or Public Holiday;
- (iii) A rails fee not exceeding \$114 for any other licensed race-meeting.

#### SCHEDULED CLUBS WHICH CONDUCT REGISTERED RACE-MEETINGS

Apsley Racing Club  
 Ararat Turf Club  
 Avoca Shire Turf Club  
 Bacchus Marsh St Patrick's Race Club  
 Bairnsdale Racing Club  
 Bairnsdale Hibernian Racing Club  
 Ballan Jockey Club  
 Ballarat Turf Club  
 Benalla Racing Club  
 Benalla St Patrick's Racing Club  
 Burrumbeet Park and Windermere Racing Club  
 Camperdown Turf Club  
 Casterton Racing Club  
 Chiltern St Patrick's Racing Club  
 Colac Turf Club  
 Coleraine Racing Club  
 Cranbourne Turf Club  
 Donald and District Race Club  
 Dunkeld Racing Club  
 Echuca Racing Club  
 Edenhope Race Club  
 Elmore Racing Club  
 Geelong Racing Club  
 Geelong St Patrick's Race Club  
 Goulburn Valley Racing Club  
 Great Western Race Club  
 Gunbower Race Club  
 Hamilton Racing Club  
 Hanging Rock Racing Club  
 Horsham and District Racing Club  
 Kerang Turf Club  
 Kilmore Turf Club  
 Kilmore St Patrick's Racing Club

Koroit Racing Club  
 Kyneton District Racing Club  
 Manangatang Racing Club  
 Mansfield District Racing Club  
 Marma Turf Club  
 Marong Racing Club  
 Mildura Racing Club  
 Moe Racing Club  
 Mornington Racing Club  
 Mortlake Racing Club  
 Mount Wycheproof and District Racing Club  
 Murtoa Racing Club  
 Nhill and Districts Racing Club  
 Pakenham Racing Club  
 Penshurst and District Racing Club  
 Purnim Racing Club  
 Quambatook Racing Club  
 Sale Turf Club  
 Seymore Racing Club  
 Sheep Hills Turf Club  
 South Gippsland Racing Club  
 St Arnaud Turf Club  
 Stawell Amateur Turf Club  
 Swan Hill Jockey Club  
 Swan Hill St Patrick's Race Club  
 Terang and District Racing Club  
 Towong Turf Club  
 Traralgon Racing Club  
 Wangarrata Turf Club  
 Wangarrata St Patrick's Racing Club  
 Warracknabeal Turf Club  
 Warrnambool Racing Club  
 Werribee Racing Club  
 Wodonga Turf Club  
 Wodonga St Patrick's Racing Club  
 Woodford Racing Club  
 Yarra Glen Racing Club

#### CLUBS WHICH CONDUCT PICNIC RACE-MEETINGS

Alexandra Race Club  
 Alexandra St Mary's Picnic Race Club  
 Balnarring Picnic Racing Club  
 Buchan and Gelantipy Race Club  
 Colac St Patrick's Racing Club  
 Dederang Picnic Race Club  
 Drouin and District Race Club  
 Goulburn Valley and District Picnic Race Club  
 Healesville Amateur Racing Club  
 Healesville St Patrick's Racing Club  
 Merton Amateur Turf Club  
 Ormeo and District Racing Club  
 Pakenham Picnic Racing Club  
 Phillip Island Racing Club  
 Tambo Valley Picnic Racing Club  
 Wonthaggi Picnic Racing Club  
 Woolamai Picnic Racing Club  
 Yarra Glen and Lilydale Hunt Club  
 Yea Racing Club  
 Yea St Patrick's Race Club

And the Honourable Neil Benjamin Trezise, Her Majesty's Minister for Sport and Recreation for the State of Victoria, shall give the necessary direction herein accordingly.

L. G. HOUSTON  
Clerk of the Executive Council

#### MINES ACT 1958

*At the Executive Council Chamber, Melbourne, the first day of July 1986*

PRESENT:

His Excellency the Governor of Victoria  
Mr Kennan | Mr McCutcheon  
Mr Roper

#### APPOINTMENT OF DEPUTY MINING WARDEN

In pursuance of the powers conferred by the *Mines Act 1958* and all other powers him thereunto enabling, His Excellency the Governor of the State of Victoria, by and with the advice of the Executive Council thereof, doth hereby appoint Alan Edward Scott to be the deputy mining warden for a period of eight weeks commencing Saturday, 5 July 1986 and concluding Friday, 29 August 1986 (both dates inclusive).

And the Honourable Robert Clive Fordham, Her Majesty's Minister for Industry, Technology and Resources for the State of Victoria, shall give the necessary directions herein accordingly.

L. G. HOUSTON  
Clerk of the Executive Council

#### MINES ACT 1958

*At the Executive Council Chamber, Melbourne, the first day of July 1986*

PRESENT:

His Excellency the Governor of Victoria  
Mr Kennan | Mr McCutcheon  
Mr Roper

#### EXEMPTION OF LAND PURSUANT TO SECTION 7 OF THE MINES ACT 1958

Whereas in section 7 of the *Mines Act 1958*, it is amongst other things provided that the Governor in Council may at any time except from occupation for prospecting or mining purposes under any miner's right or from being leased under a mining lease or development lease or from being licensed under section 81, 82, 85 or 325 any specific portions of Crown lands.

Now therefore, His Excellency the Governor in the State of Victoria, in the Commonwealth of Australia, by and with the advice of the Executive Council of the said State, and in pursuance of the powers conferred by section 7 of the *Mines Act 1958* and all other powers him thereunto enabling, doth

by this order, except from occupation for prospecting or mining purposes under any miner's right or from being licensed under section 81, 82, 85 or 325, all those pieces of land indicated by hatching situated in the parish of Sandhurst and including the red calcined dumps know as Leggo's and Liddell's dumps, as per the plan hereunder.

#### LEGGO'S AND LIDDELLS RED CALCINED DUMPS PARISH OF SANDHURST

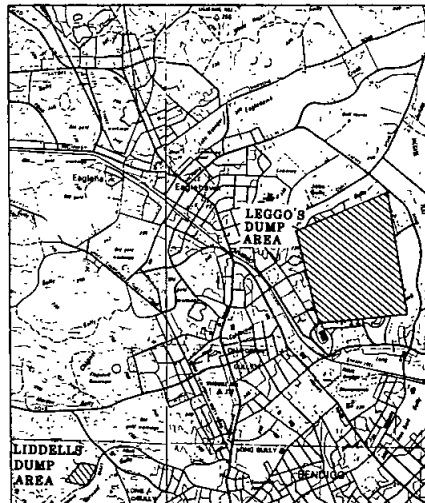

And the Honourable Robert Clive Fordham, Her Majesty's Minister for Industry, Technology and Resources for the State of Victoria, shall give the necessary directions herein accordingly.

L. G. HOUSTON  
Clerk of the Executive Council

#### VICTORIAN CIVIL AMBULANCE SERVICE ACT 1974 Section 4

*At the Executive Council Chamber, Melbourne, the first day of July 1986*

PRESENT:

His Excellency the Governor of Victoria  
Mr Kennan | Mr McCutcheon  
Mr Roper

Pursuant to the powers conferred by the *Victorian Civil Ambulance Service Act 1974* and all other powers him thereunto enabling, His Excellency the Governor of the State of Victoria in the

Commonwealth of Australia, by and with the advice of the Executive Council of the said State, doth by this order appoint the undermentioned persons to constitute the Committee of Management of the Ambulance Service—Melbourne for a period of office expiring on 30 June 1989.

Graeme Thomas John  
Bernard Clarke  
Merle Valma Mitchell  
Neil David Armstrong  
William Henry Pyle  
Phillip David Murphy  
Raoul de Crespigny Tunbridge

and further appoints:

Graeme Thomas John to be President, and  
Bernard Clarke to be Vice President, and  
Neil David Armstrong to be Treasurer.

And the Honourable David Ronald White, Her Majesty's Minister for Health for the State of Victoria, shall give the necessary directions herein accordingly.

L. G. HOUSTON  
Clerk of the Executive Council

**MARKETING OF PRIMARY PRODUCTS ACT  
1958**

*At the Executive Council Chamber, Melbourne, the  
first day of July 1986*

PRESENT:

His Excellency the Governor of Victoria  
Mr Kennan | Mr McCutcheon  
Mr Roper

**CITRUS FRUIT MARKETING BOARD**

In pursuance of the powers conferred by sections 8 and 11 of the *Marketing of Primary Products Act 1958*, and all other powers him thereunto enabling, His Excellency the Governor of the State of Victoria, by and with the advice of the Executive Council thereof, hereby appoints—

Douglas John CHISLETT to be Member and Chairperson;

Ann Elizabeth ORTON to be Member and Deputy Chairperson;

Ivan Rodger COCKROFT to be a Member;

Frank Lawrence GAULKE to be a Member; and

Aldo BASILE to be a Member—

of the Citrus Fruit Marketing Board for the period ending 30 June 1987.

And the Honourable Evan Walker, Her Majesty's Minister for Agriculture and Rural Affairs for the State of Victoria, shall give the necessary directions herein accordingly.

L. G. HOUSTON  
Clerk of the Executive Council

*Water Act 1958*  
**RURAL WATER COMMISSION OF  
VICTORIA**

*At the Executive Council Chamber, Melbourne, the  
first day of July 1986*

PRESENT:

His Excellency the Governor of Victoria  
Mr Kennan | Mr McCutcheon  
Mr Roper

**NORMANVILLE WATERWORKS  
DISTRICT—DISTRICT EXTENDED**

Under the powers conferred by the *Water Act 1958* and all other powers enabling him in that behalf, His Excellency the Governor of the State of Victoria, with the advice of the Executive Council of the said State, on the recommendation of the Rural Water Commission of Victoria, doth hereby declare, order and direct that the Normanville Waterworks District be extended by adding to the same the land shown by blue colour on a plan approved by the Governor in Council and deposited in the office of the Rural Water Commission of Victoria at 590 Orrong Road, Armadale (Corr. No. 78/1147), and as on and from 1 August 1986, such district shall be deemed to be so extended.

And the Honourable Andrew McCutcheon, Her Majesty's Minister for Water Resources for the State of Victoria, shall give the necessary directions herein accordingly.

L. G. HOUSTON  
Clerk of the Executive Council

*Water Act 1958*  
**RURAL WATER COMMISSION OF  
VICTORIA**

*At the Executive Council Chamber, Melbourne, the  
first day of July 1986*

PRESENT:

His Excellency the Governor of Victoria  
Mr Kennan | Mr McCutcheon  
Mr Roper

**GOULBURN—MURRAY IRRIGATION  
DISTRICT—PORTIONS EXCISED  
RODNEY IRRIGATION AREA—  
BOUNDARIES VARIED**

Under the powers conferred by the *Water Act 1958* and all other powers enabling him in that behalf, His Excellency the Governor of the State of Victoria, with the advice of the Executive Council of the said State, on the recommendation of the Rural Water Commission of Victoria, doth hereby declare, order and direct that there shall be excised from the Goulburn—Murray Irrigation District the lands shown by green colour on a plan approved by the Governor in Council and deposited in the office of the Rural Water Commission of Victoria at 590



Orrong Road, Armadale (Corr. No. 85/1874), and that the boundaries of the Rodney Irrigation Area shall be varied to excise therefrom such lands which shall be deemed to be excised from the said irrigation district and irrigation area as on and from 31 July 1986.

And the Honourable Andrew McCutcheon, Her Majesty's Minister for Water Resources for the State of Victoria, shall give the necessary directions herein accordingly.

L. G. HOUSTON  
Clerk of the Executive Council

#### LOCAL GOVERNMENT ACT 1958

*At the Executive Council Chamber, Melbourne, the first day of July 1986*

PRESENT:

His Excellency the Governor of Victoria		Mr McCutcheon
Mr Kennan		
Mr Roper		

#### SHIRE OF BARRABOOL

Authorization of works or undertakings for the purposes of Division 5 of Part X. of the *Local Government Act 1958*

Whereas it is provided in section 277 (2) of the *Local Government Act 1958* that any works or undertakings not authorized by that Act (being works or undertakings that are for the special benefit of any particular portion of the municipal district) may, on the application of the council of the municipality, be authorized by Order of the Governor in Council published in the *Government Gazette* and the council may make and levy a rate herein called a "separate rate" in respect of rateable property in such portion exclusively.

And whereas the Council of the Shire of Barrabool has made application to have the works or undertakings of electricity reticulation in portion of the municipal district of the shire (being works or undertakings that are for the special benefit to that particular portion of the municipal district) to be authorized works or undertakings for the purposes of Division 5 of Part X. of the *Local Government Act 1958*.

Now therefore, His Excellency the Governor of the State of Victoria, by and with the advice of the Executive Council thereof and in pursuance of the said section 277 (2), does by this Order authorize the works of electrical reticulation to Lots 1-14 inclusive on Plan of Submission No. 11053 in the municipal district of the Shire of Barrabool to be an authorized work or undertaking for the purpose of the said Division 5 of Part X. of the *Local Government Act 1958*.

And the Honourable James Lionel Simmonds, Her Majesty's Minister for Local Government for the State of Victoria, shall give the necessary directions herein accordingly.

L. G. HOUSTON  
Clerk of the Executive Council

#### HEALTH ACT 1958

*At the Executive Council Chamber, Melbourne, the first day of July 1986*

PRESENT:

His Excellency the Governor of Victoria		
Mr Kennan		Mr McCutcheon
Mr Roper		

#### DIVISION 1 OF PART V. OF THE HEALTH ACT 1958 RELATING TO PIGGERIES TO BE EXTENDED TO THE WHOLE OF THE MUNICIPAL DISTRICT OF THE SHIRE OF STRATHFIELDSAYE

Pursuant to the powers conferred by section 94 (2) of the *Health Act 1958* and all other powers enabling him in that behalf, His Excellency the Governor of the State of Victoria, by and with the advice of the Executive Council of the said State, and on the recommendation of the Chief General Manager of the Department of Health Victoria, doth hereby vary the order dated 23 May 1944 in which the provisions of Division 1 of Part V. of the *Health Act 1928* (now Division 1 of Part V. of the *Health Act 1958*), so far as those provisions are applicable to piggeries, were extended to that portion of the Shire of Strathfieldsaye which lies within the boundaries of the Parish of Sandhurst to include the whole of the municipal district of the Shire of Strathfieldsaye.

And the Honourable David Ronald White, Her Majesty's Minister for Health for the State of Victoria, shall give the necessary directions herein accordingly.

L. G. HOUSTON  
Clerk of the Executive Council

#### CROWN LAND (RESERVES) ACT 1978

*At the Executive Council Chamber, Melbourne, the first day of July 1986*

PRESENT:

His Excellency the Governor of Victoria		
Mr Kennan		Mr McCutcheon
Mr Roper		

#### CROWN LAND TEMPORARILY RESERVED

His Excellency the Governor of the State of Victoria, in the Commonwealth of Australia, by and with the advice of the Executive Council of the said State, pursuant to the provisions of sections 4

and 7 of the *Crown Land (Reserves) Act 1978* and being of the opinion that the Crown land concerned is required for the purposes mentioned, hereby temporarily reserves and also excepts from prospecting or from occupation for mining purposes under any miners right the Crown land hereinafter described, viz.:

Municipal District of the Shire of Deakin—for the purpose of a public park—4560 square metres more or less being Crown allotments 15 and 18 Section 6, Township of Girgarre, Parish of Kyabram, as indicated by the hatching hereunder—(G175<sup>(A4)</sup>) (Rs. 13052).

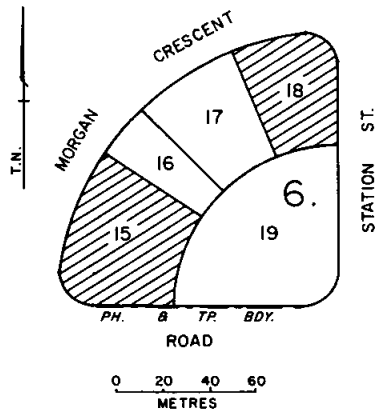

Total area of hatched portions 4560m<sup>2</sup>±

And the Honourable Joan Elizabeth Kirner, Her Majesty's Minister for Conservation, Forests and Lands for the State of Victoria, shall give the necessary directions herein accordingly.

L. G. HOUSTON  
Clerk of the Executive Council

**CROWN LAND (RESERVES) ACT 1978**

At the Executive Council Chamber, Melbourne, the first day of July 1986

PRESENT:

His Excellency the Governor of Victoria	
Mr Kennan	Mr McCutcheon
Mr Roper	

**CROWN LAND TEMPORARILY RESERVED**

His Excellency the Governor of the State of Victoria, in the Commonwealth of Australia, by and with the advice of the Executive Council of the said State, pursuant to the provisions of sections 4 and 7 of the *Crown Land (Reserves) Act 1978* and being of the opinion that the Crown land concerned is required for the purposes mentioned, hereby

temporarily reserves and also excepts from prospecting or from occupation for mining purposes under any miners right the Crown land hereinafter described, viz.:

In the Municipal District of the Shire of Kerang—for public recreation—2.5 hectares more or less being Crown allotment 1a Section C, Parish of Dartagook as indicated by hatching on the plan hereunder—(D188<sup>(6)</sup>) (Rs. 12956).

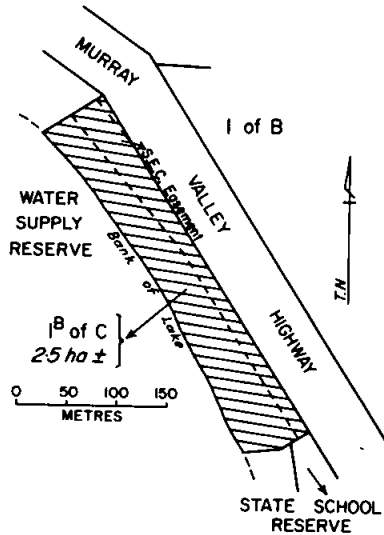

And the Honourable Joan Elizabeth Kirner, Her Majesty's Minister for Conservation, Forests and Lands for the State of Victoria, shall give the necessary directions herein accordingly.

L. G. HOUSTON  
Clerk of the Executive Council

**CROWN LAND (RESERVES) ACT 1978**

At the Executive Council Chamber, Melbourne, the first day of July 1986

PRESENT:

His Excellency the Governor of Victoria	
Mr Kennan	Mr McCutcheon
Mr Roper	

**CROWN LAND TEMPORARILY RESERVED**

His Excellency the Governor of the State of Victoria, in the Commonwealth of Australia, by and with the advice of the Executive Council of the said State, pursuant to the provisions of sections 4 and 7 of the *Crown Land (Reserves) Act 1978* and being of the opinion that the Crown land concerned is required for the purposes mentioned, hereby

temporarily reserves and also excepts from prospecting or from occupation for mining purposes under any miners right the Crown land hereinafter described, viz.:

Municipal District of the Shire of Rosedale—for the purposes of public park—7 hectares more or less, being Crown allotment 9A Section 3A, Township of Rosedale, Parish of Rosedale as indicated by hatching on plan hereunder—(R35<sup>(3)</sup>) (Rs. 12919).

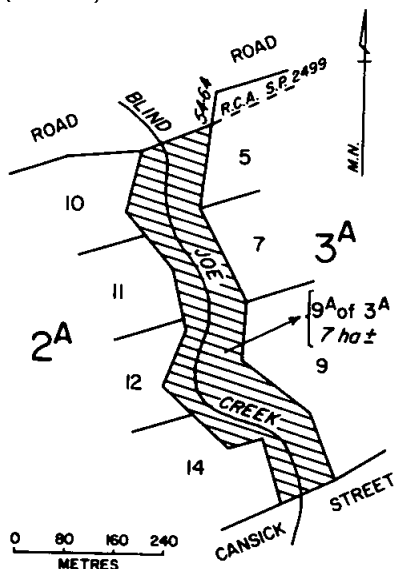

And the Honourable Joan Elizabeth Kirner, Her Majesty's Minister for Conservation, Forests and Lands for the State of Victoria, shall give the necessary directions herein accordingly.

L. G. HOUSTON  
Clerk of the Executive Council

**CROWN LAND (RESERVES) ACT 1978**

At the Executive Council Chamber, Melbourne, the first day of July 1986

PRESENT:

His Excellency the Governor of Victoria  
Mr Kennan | Mr McCutcheon  
Mr Roper

**CROWN LAND TEMPORARILY RESERVED**

His Excellency the Governor of the State of Victoria, in the Commonwealth of Australia, by and with the advice of the Executive Council of the said State, pursuant to the provisions of sections 4 and 7 of the *Crown Land (Reserves) Act 1978* and

being of the opinion that the Crown land concerned is required for the purposes mentioned, hereby temporarily reserves and also excepts from prospecting or from occupation for mining purposes under any miners right the Crown land hereinafter described, viz.:

Municipal District of the Shire of Daylesford and Glenlyon—for the purposes of mineral springs and public park—1.859 hectares, being Crown allotment 31C Section 24, Township of Hepburn, Parish of Wombat as indicated by hatching on plan hereunder—(H118<sup>(3)</sup>) (Rs. 13043).

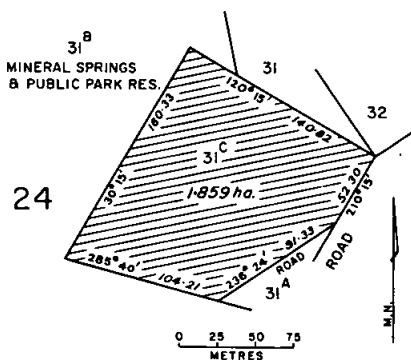

And the Honourable Joan Elizabeth Kirner, Her Majesty's Minister for Conservation, Forests and Lands for the State of Victoria, shall give the necessary directions herein accordingly.

L. G. HOUSTON  
Clerk of the Executive Council

**CROWN LAND (RESERVES) ACT 1978**

At the Executive Council Chamber, Melbourne, the first day of July 1986

PRESENT:

His Excellency the Governor of Victoria  
Mr Kennan | Mr McCutcheon  
Mr Roper

**CROWN LAND TEMPORARILY RESERVED**

His Excellency the Governor of the State of Victoria, in the Commonwealth of Australia, by and with the advice of the Executive Council of the said State, pursuant to the provisions of sections 4 and 7 of the *Crown Land (Reserves) Act 1978* and being of the opinion that the Crown land concerned is required for the purposes mentioned, hereby temporarily reserves and also excepts from prospecting or from occupation for mining purposes under any miners right the Crown land hereinafter described, viz.:

Municipal District of the Shire of Leigh—for the purpose of a swimming pool—1.2 hectares being Crown allotment 8, section 9, Township of Rokewood, Parish of Corindhap as indicated by hatching on plan hereunder—(R51<sup>(3)</sup>) (Rs. 5230).

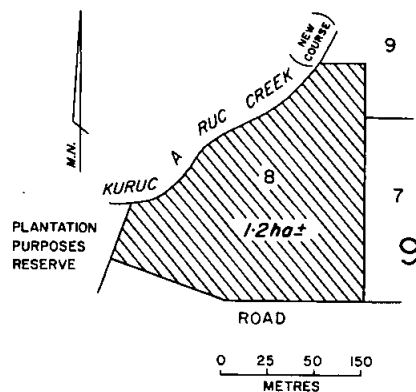

And the Honourable Joan Elizabeth Kirner, Her Majesty's Minister for Conservation, Forests and Lands for the State of Victoria, shall give the necessary directions herein accordingly.

L. G. HOUSTON  
Clerk of the Executive Council

CROWN LAND (RESERVES) ACT 1978

At the Executive Council Chamber, Melbourne, the first day of July 1986

PRESENT:

His Excellency the Governor of Victoria

Mr Kennan | Mr McCutcheon  
Mr Roper

CROWN LAND TEMPORARILY RESERVED

His Excellency the Governor of the State of Victoria, in the Commonwealth of Australia, by and with the advice of the Executive Council of the said State, pursuant to the provisions of sections 4 and 7 of the *Crown Land (Reserves) Act 1978* and being of the opinion that the Crown land concerned is required for the purposes mentioned, hereby temporarily reserves and also excepts from prospecting or from occupation for mining purposes under any miners right the Crown land hereinafter described, viz.:

Municipal District of the Shire of Marong—for the purpose of a public park—5000 square metres more or less being Crown allotment 4, section 4A,

Township of Kangaroo Flat, Parish of Sandhurst as indicated by hatching on plan hereunder—(5403) Rs. 12553).

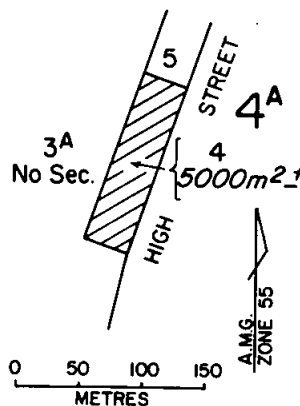

And the Honourable Joan Elizabeth Kirner, Her Majesty's Minister for Conservation, Forests and Lands for the State of Victoria, shall give the necessary directions herein accordingly.

L. G. HOUSTON  
Clerk of the Executive Council

CROWN LAND (RESERVES) ACT 1978

At the Executive Council Chamber, Melbourne, the first day of July 1986

PRESENT:

His Excellency the Governor of Victoria  
Mr Kennan | Mr McCutcheon  
Mr Roper

CROWN LAND TEMPORARILY RESERVED

His Excellency the Governor of the State of Victoria, in the Commonwealth of Australia, by and with the advice of the Executive Council of the said State, pursuant to the provisions of sections 4 and 7 of the *Crown Land (Reserves) Act 1978* and being of the opinion that the Crown land concerned is required for the purposes mentioned, hereby temporarily reserves and also excepts from prospecting or from occupation for mining purposes under any miners right the Crown land hereinafter described, viz.:

Municipal District of the Shire of Korong—for the purpose of public purposes—2700 square metres more or less being Crown allotment 15, Township of Borung, Parish of Borung as indicated by hatching on plan hereunder—(B89<sup>(11)</sup>) (Rs. 13130).

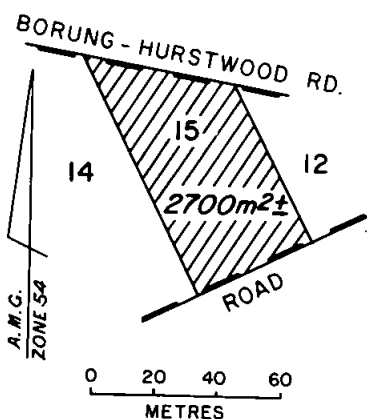

And the Honourable Joan Elizabeth Kirner, Her Majesty's Minister for Conservation, Forests and Lands for the State of Victoria, shall give the necessary directions herein accordingly.

L. G. HOUSTON  
Clerk of the Executive Council

**CROWN LAND (RESERVES) ACT 1978**

At the Executive Council Chamber, Melbourne, the first day of July 1986

PRESENT:

His Excellency the Governor of Victoria  
Mr Kennan | Mr McCutcheon  
Mr Roper

**CROWN LAND TEMPORARILY RESERVED**

His Excellency the Governor of the State of Victoria, in the Commonwealth of Australia, by and with the advice of the Executive Council of the

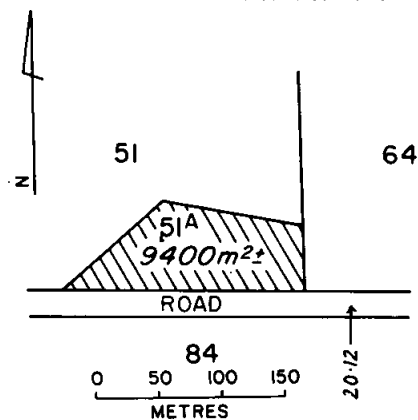

said State, pursuant to the provisions of sections 4 and 7 of the *Crown Land (Reserves) Act 1978* and being of the opinion that the Crown land concerned is required for the purposes mentioned, hereby temporarily reserves and also excepts from prospecting or from occupation for mining purposes under any miners right the Crown land hereinafter described, viz.:

Municipal District of the Shire of Kowree—for water supply purposes—9400 square metres more or less being Crown allotment 51A, Parish of Goroke as indicated by hatching on plan hereunder—(G214<sup>(4)</sup>) (L4-1507).

And the Honourable Joan Elizabeth Kirner, Her Majesty's Minister for Conservation, Forests and Lands for the State of Victoria, shall give the necessary directions herein accordingly.

L. G. HOUSTON  
Clerk of the Executive Council

**CROWN LAND (RESERVES) ACT 1978**

At the Executive Council Chamber, Melbourne, the first day of July 1986

PRESENT:

His Excellency the Governor of Victoria  
Mr Kennan | Mr McCutcheon  
Mr Roper

**CROWN LAND TEMPORARILY RESERVED**

His Excellency the Governor of the State of Victoria, in the Commonwealth of Australia, by and with the advice of the Executive Council of the said State, pursuant to the provisions of sections 4 and 7 of the *Crown Land (Reserves) Act 1978* and being of the opinion that the Crown land concerned is required for the purposes mentioned, hereby temporarily reserves and also excepts from prospecting or from occupation for mining purposes under any miners right the Crown land hereinafter described, viz.:

Municipal District of the Shire of Mildura—for conservation of an area of natural interest—8700 square metres—being Crown allotment 519B Section B, Parish of Mildura as indicated by hatching on plan hereunder—(M556<sup>(23)</sup>) (Rs. 12918).

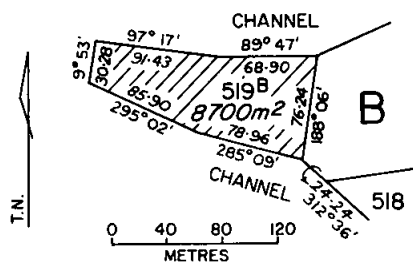

And the Honourable Joan Elizabeth Kirner, Her Majesty's Minister for Conservation, Forests and Lands for the State of Victoria, shall give the necessary directions herein accordingly.

L. G. HOUSTON  
Clerk of the Executive Council

And the Honourable Joan Elizabeth Kirner, Her Majesty's Minister for Conservation, Forests and Lands for the State of Victoria, shall give the necessary directions herein accordingly.

L. G. HOUSTON  
Clerk of the Executive Council

**CROWN LAND (RESERVES) ACT 1978**

*At the Executive Council Chamber, Melbourne, the first day of July 1986*

PRESENT:

His Excellency the Governor of Victoria  
Mr Kennan | Mr McCutcheon  
Mr Roper

**CROWN LAND TEMPORARILY RESERVED**

His Excellency the Governor of the State of Victoria, in the Commonwealth of Australia, by and with the advice of the Executive Council of the said State, pursuant to the provisions of sections 4 and 7 of the *Crown Land (Reserves) Act 1978* and being of the opinion that the Crown land concerned is required for the purposes mentioned, hereby temporarily reserves and also exempts from prospecting or from occupation for mining purposes under any miners right the Crown land hereinafter described, viz.:

Municipal District of the City of Wangaratta for the purpose of a public park—5200 square metres more or less, being Crown allotment D, Township of Wangaratta, Parish of Wangaratta North, as indicated by hatching on plan hereunder—(W85<sup>(a)</sup>) (Rs. 13131).

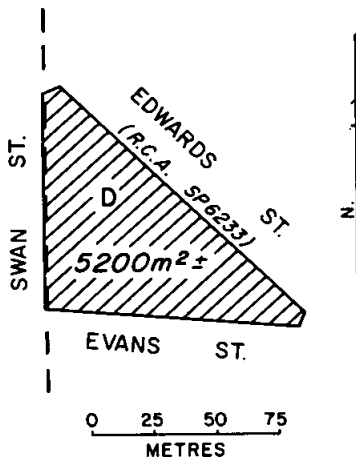

**CROWN LAND (RESERVES) ACT 1978**

*At the Executive Council Chamber, Melbourne, the first day of July 1986*

PRESENT:

His Excellency the Governor of Victoria  
Mr Kennan | Mr McCutcheon  
Mr Roper

**CROWN LAND TEMPORARILY RESERVED**

His Excellency the Governor of the State of Victoria, in the Commonwealth of Australia, by and with the advice of the Executive Council of the said State, pursuant to the provisions of sections 4 and 7 of the *Crown Land (Reserves) Act 1978* and being of the opinion that the Crown land concerned is required for the purposes mentioned, hereby temporarily reserves and also exempts from prospecting or from occupation for mining purposes under any miners right the Crown land hereinafter described, viz.:

Municipal District of the Shire of Omeo—for conservation of an area of natural interest—22.3 hectares more or less, being Crown allotments 101 and 102, Parish of Cobungra as indicated by hatching on plan hereunder—(C372<sup>(a)</sup>) (Rs. 12690).

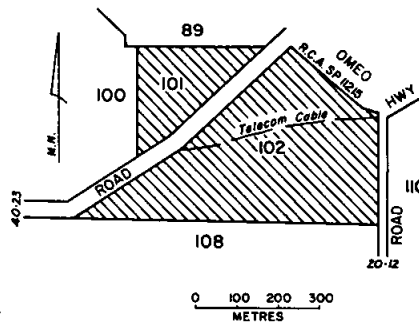

Total area of hatched portions 22.3 ha ±

And the Honourable Joan Elizabeth Kirner, Her Majesty's Minister for Conservation, Forests and Lands for the State of Victoria, shall give the necessary directions herein accordingly.

L. G. HOUSTON  
Clerk of the Executive Council

**CROWN LAND (RESERVES) ACT 1978**

*At the Executive Council Chamber, Melbourne, the first day of July 1986*

PRESENT:

His Excellency the Governor of Victoria  
 Mr Kennan | Mr McCutcheon  
 Mr Roper

**CROWN LAND TEMPORARILY RESERVED**

His Excellency the Governor of the State of Victoria, in the Commonwealth of Australia, by and with the advice of the Executive Council of the said State, pursuant to the provisions of sections 4 and 7 of the *Crown Land (Reserves) Act 1978* and being of the opinion that the Crown land concerned

is required for the purposes mentioned, hereby temporarily reserves and also excepts from prospecting or from occupation for mining purposes under any miners right the Crown land hereinafter described, viz.:

Municipal District of the Shire of Strathfieldsaye—for conservation of an area of natural interest—5.2 hectares more or less, being Crown allotment 541F Section 14, Parish of Sandhurst as indicated by hatching on plan hereunder—(s 371(47)) (Rs. 11690).

And the Honourable Joan Elizabeth Kirner, Her Majesty's Minister for Conservation, Forests and Lands for the State of Victoria, shall give the necessary directions herein accordingly.

L. G. HOUSTON  
 Clerk of the Executive Council

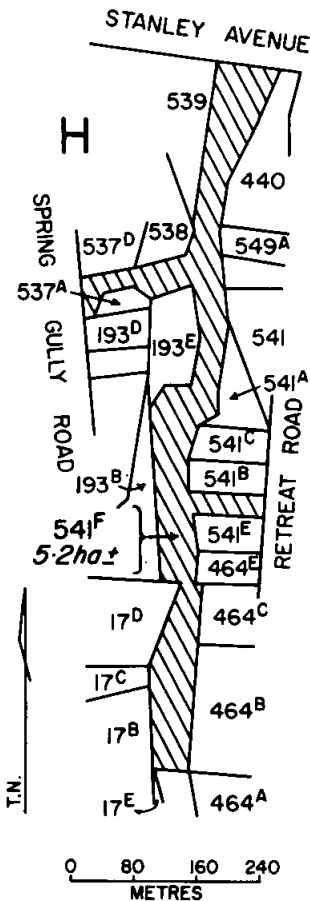

**CROWN LAND (RESERVES) ACT 1978**

*At the Executive Council Chamber, Melbourne, the first day of July 1986*

PRESENT:

His Excellency the Governor of Victoria  
 Mr Kennan | Mr McCutcheon  
 Mr Roper

**CROWN LAND TEMPORARILY RESERVED**

His Excellency the Governor of the State of Victoria, in the Commonwealth of Australia, by and with the advice of the Executive Council of the said State, pursuant to the provisions of sections 4 and 7 of the *Crown Land (Reserves) Act 1978* and being of the opinion that the Crown land concerned is required for the purposes mentioned, hereby temporarily reserves and also excepts from prospecting or from occupation for mining purposes under any miners right the Crown land hereinafter described, viz.:

Municipal District of the Shire of Stawell—for conservation of an area of historic interest—4.4 hectares more or less being Crown allotment 177C, Parish of Illawarra, as indicated by hatching on plan hereunder—(Rs. 13041).

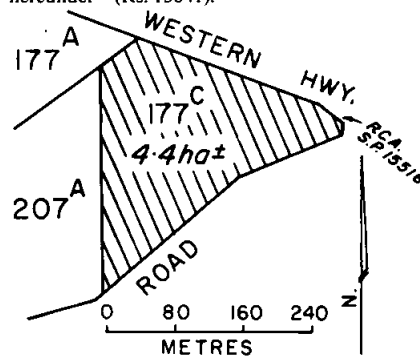

And the Honourable Joan Elizabeth Kirner, Her Majesty's Minister for Conservation, Forests and Lands for the State of Victoria, shall give the necessary directions herein accordingly.

L. G. HOUSTON  
Clerk of the Executive Council

#### CROWN LAND (RESERVES) ACT 1978

*At the Executive Council Chamber, Melbourne, the first day of July 1986*

PRESENT:

His Excellency the Governor of Victoria	
Mr Kennan	Mr McCutcheon
Mr Roper	

#### CROWN LAND TEMPORARILY RESERVED

His Excellency the Governor of the State of Victoria, in the Commonwealth of Australia, by and with the advice of the Executive Council of the said State, pursuant to the provisions of sections 4 and 7 of the *Crown Land (Reserves) Act 1978* and being of the opinion that the Crown land concerned is required for the purposes mentioned, hereby temporarily reserves and also excepts from prospecting or from occupation for mining purposes under any miners right the Crown land hereinafter described, viz.:

Municipal District of the City of Traralgon—for health purposes—724 square metres bring Crown allotment 22D, Parish of Traralgon, formerly being Lot 20 Plan of Subdivision 122790 lodged in the Office of Titles—(T 115<sup>(11)</sup>) (Rs. 13243).

And the Honourable Joan Elizabeth Kirner, Her Majesty's Minister for Conservation, Forests and Lands for the State of Victoria, shall give the necessary directions herein accordingly.

L. G. HOUSTON  
Clerk of the Executive Council

#### CROWN LAND (RESERVES) ACT 1978

*At the Executive Council Chamber, Melbourne, the first day of July 1986*

PRESENT:

His Excellency the Governor of Victoria	
Mr Kennan	Mr McCutcheon
Mr Roper	

#### CROWN LAND TEMPORARILY RESERVED

His Excellency the Governor of the State of Victoria, in the Commonwealth of Australia, by and with the advice of the Executive Council of the said State, pursuant to the provisions of sections 4 and 7 of the *Crown Land (Reserves) Act 1978* and being of the opinion that the Crown land concerned is required for the purposes mentioned, hereby temporarily reserves and also excepts from

prospecting or from occupation for mining purposes under any miners right the Crown land hereinafter described, viz.:

Municipal District of the City of Broadmeadows—Parish of Tullamarine—for health purposes—541 square metres being Crown allotment 6A, formerly being Lot 37 on Plan of Subdivision 82109 lodged in the Office of Titles—(T117<sup>(4)</sup>) (Rs.13018).

And the Honourable Joan Elizabeth Kirner, Her Majesty's Minister for Conservation, Forests and Lands for the State of Victoria, shall give the necessary directions herein accordingly.

L. G. HOUSTON  
Clerk of the Executive Council

#### CROWN LAND (RESERVES) ACT 1978

*At the Executive Council Chamber, Melbourne, the first day of July 1986*

PRESENT:

His Excellency the Governor of Victoria	
Mr Kennan	Mr McCutcheon
Mr Roper	

#### CROWN LAND TEMPORARILY RESERVED

His Excellency the Governor of the State of Victoria, in the Commonwealth of Australia, by and with the advice of the Executive Council of the said State, pursuant to the provisions of sections 4 and 7 of the *Crown Land (Reserves) Act 1978* and being of the opinion that the Crown land concerned is required for the purposes mentioned, hereby temporarily reserves and also excepts from prospecting or from occupation for mining purposes under any miners right the Crown land hereinafter described, viz.:

Municipal District of the City of Shepparton—for health purposes—836 square metres being Crown allotment 5C, Parish of Shepparton, formerly being Lot 172 on Plan of Subdivision 11868 lodged in the Office of Titles—(S283<sup>(9)</sup>) (Rs. 12874).

And the Honourable Joan Elizabeth Kirner, Her Majesty's Minister for Conservation, Forests and Lands for the State of Victoria, shall give the necessary directions herein accordingly.

L. G. HOUSTON  
Clerk of the Executive Council

## TENDERS

### PUBLIC WORKS DEPARTMENT

Tenders are invited for the purposes indicated hereunder and will be received at 2 Treasury Place, Melbourne, 3002, until TWO p.m. on the dates shown.



Tenders must be addressed to the Minister for Public Works with the envelope endorsed "Tender for \_\_\_\_\_".

Tenders forwarded either by mail, telegram or telex, which arrive after the closing time, will be accepted provided that the official Telecom or Australia Post time and date stamping indicates dispatch prior to the closing time. (TIME AND DATE STAMPING MUST BE REQUESTED AT SOME POST OFFICES.)

(TELEX No. AA152039)

Hand-delivered tenders must be placed in the Department's tender box in foyer, Ground Floor, 2 Treasury Place, Melbourne.

Tenders documents are available from the Contracts Office, Room 29, Ground Floor, 2 Treasury Place, Melbourne and where indicated, at offices of Inspector of Works.

### Wednesday, 16 July 1986

#### Building, Electrical and Mechanical Services

BELFIELD—Upgrade of water supply and fire service, Primary School.

LAVERTON—Air-conditioning to Security/Vital Records area, Public Record Office Repository.

#### Miscellaneous

KNOX (Outer Eastern)—Supply of horticultural laboratory equipment, T1168, College of T.A.F.E.

### Wednesday, 23 July 1986

#### Building, Electrical and Mechanical Services

ARMADALE—Internal cyclic maintenance, alterations and additions, Treloarwarren Hostel, Health Department.

COBURG (Contract No. 1)—New building, Drug Treatment Unit, Metropolitan Reception Prison.

COBURG (Contract No. 2)—Alterations, Drug Treatment Unit, Metropolitan Reception Prison.

#### Miscellaneous

VARIOUS—Supply of domestic equipment for the period 1 July 1986 to 30 June 1987, Schools and other Government Departments.

### Wednesday, 30 July 1986

#### Building, Electrical and Mechanical Services

MELBOURNE—Fitting out works, Stage 2, Ground Floor, 594 St. Kilda Road, Department of Health.

SHEPPARTON (Re-advertised)—Internal and external repairs and painting, Primary School (W.O. Shepparton).

RONALD W. WALSH  
Minister for Public Works

Public Works Department  
Melbourne, 7 July 1986

### DEPARTMENT OF PROPERTY AND SERVICES

Tenders are invited for the services indicated hereunder and will be received at the Property Division, Department of Property and Services, 3rd Floor, 35 Spring Street, Melbourne 3000 until TWO p.m. on the dates shown.

Specifications and Tender documents are available from the Property Division Office at the above address (Phone: 651 3581) or, where indicated, at other locations.

Late tenders will not be considered.

### Wednesday, 16 July 1986

ARARAT—Maintenance cleaning, period 1 August 1986 to 31 July 1989. Court House, Barkly Street. (Documents available at Ararat Court House.)

FOOTSCRAY—Security Patrol Service, period 1 August 1986 to 31 July 1987. Dental Centre, 2 Geelong Road.

Dr E. W. RUSSELL  
Director-General of Property and Services

### PRIVATE ADVERTISEMENTS

#### CITY OF GEELONG

Notice is hereby given that meetings of council held on 27 May and 24 June 1986 the council made, passed and confirmed the following By-law:

*By-Law No. 178 (Cattle Market)*

Made under the provisions of section 6 of 6 Victoria No. 18 extended to the City of Geelong pursuant to section 6 of 13 Victoria No. 40 for imposing the rates tolls and dues to be levied in the cattle market of the city.

A copy of the By-law has been deposited at the City Hall, Gheringhap Street, Geelong, and is open for inspection during the hours of 8.30 a.m. to 5.15 p.m. each day Monday to Friday.

T. J. T. NEAL  
3482 Town Clerk and Chief Administrative Officer

#### Form 2.1

*Town and Country Planning Act 1961*

#### CITY OF HAMILTON PLANNING SCHEME

Notice that a Planning Scheme has been Prepared and is Available for Inspection

Amendment No. 25

Notice is hereby given that the Council of the City of Hamilton in pursuance of its powers under the *Town and Country Planning Act 1961* has prepared a scheme for the purpose of amending the City of Hamilton Planning Scheme Ordinance so that the council may consent to the enlargement of

the adjoining non-conforming use (joinery works) in accordance with clause 16 (1) of the Ordinance onto part Crown Allotments 8 and 9 Section 61 Township of Hamilton.

A copy of the scheme has been deposited at the office of the City of Hamilton and at the office of the Ministry for Planning and Environment (Plan Inspection Section), The Olderfleet Buildings, 477 Collins Street, Melbourne and will be open for inspection during office hours by any person free of charge.

Any persons affected by the scheme are required to set forth in writing any submission they may wish to make with respect to the scheme, addressed to the Town Clerk, City of Hamilton, P.O. Box 107, Hamilton by 9 August 1986 and state whether they wish to be heard in respect of their submission.

Dated 1 July 1986

3454 R. J. WORLAND, Town Clerk

*Local Government Act 1958, Section 522*  
CITY OF FOOTSCRAY

Notice is hereby given in accordance with section 522 (2) of the *Local Government Act 1958*, that the Council of the City of Footscray at its meeting held on 14 April 1986, directed by order, that the land being Title V4022 F252 and shown hatched on the plan below shall be a public highway.

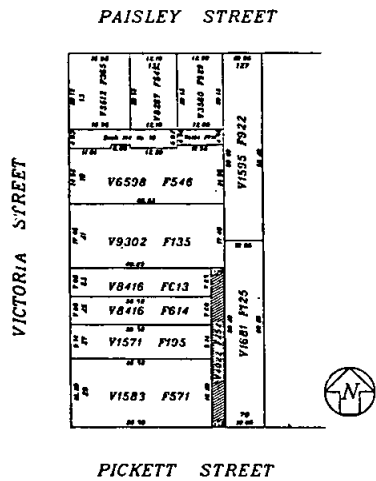

AREA OF RIGHT OF WAY SHOWN HATCHED IS TO BE DEDICATED TO THE PUBLIC AS A PUBLIC HIGHWAY UNDER SECTION 522 OF THE LOCAL GOVERNMENT ACT.

3509 B. J. WARD  
Chief Executive Officer and Town Clerk

CITY OF KEILOR

Notice of Intention to Take Land Compulsorily

Whereas the council of the City of Keilor deems it expedient to exercise its power of taking land compulsorily in accordance with the provisions of section 513 of the *Local Government Act 1958* (as amended) notice is hereby given as follows:

The council intends to acquire all that land delineated as hatched on the plan attached and more particularly described as being Lot 10 (80) Wonganella Drive, East Keilor indicated on Lodged Plan of Subdivision No. 84196 Certificate of Title Volume No. 9231 Folio 963 Parish of Dousta Galla County of Bourke for the work or undertaking of constructing a road linking Tunnecliffe Avenue to Milleara Road, East Keilor.

And whereas the council has caused to be prepared a map and other papers setting out the general description of the work or undertaking for which the land is to be used, the description of the land to be taken and the names of the owners or reputed owners, lessees or reputed lessees, mortgagees and occupiers of that land so far as those names are known or can be ascertained by council.

And whereas the said map and other papers are deposited at the office of the said council at the Municipal Offices, Calder Highway, Keilor and are

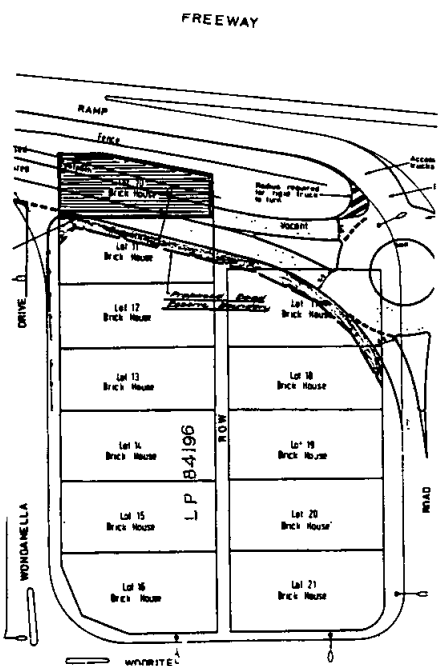

and shall be open for inspection by all persons interested at all reasonable hours for the period of 40 clear days after the publication of this notice in the *Government Gazette*.

Now notice is hereby given to all persons affected by the proposed taking of the said land to set forth in writing addressed to the council or the Town Clerk/Chief Executive Officer within 40 clear days of the publication of this notice in the *Government Gazette* all objections which they may have to the taking of the said land.

By order of the council

Dated 1 July 1986

As witness, the common seal of the municipality was hereto affixed in our presence. Dated 3 July 1986.

H. S. ARMOUR, Mayor

R. G. ISHERWOOD, Councillor

3483

R. F. B. KELLY, Town Clerk

#### CITY OF KEW

##### Road Discontinuance

Whereas section 528 (2) of the Local Government Act provides that where a road whether or not a public highway (but not being a road set out on Crown land) or any part of that road is not reasonably required as a road for public use, the council of the municipality in which such road is situated may not less than one month after publishing a public notice in a newspaper generally circulating in the municipal district and giving written notice to the registered proprietor (if any) of the road and to the owners and occupiers (if any) of any land abutting or immediately adjacent to the road of its intention to make a Resolution discontinuing such road or part thereof may by Resolution published in the *Government Gazette* direct that such road or part thereof shall be discontinued and thereupon such road or part of the road shall be discontinued accordingly.

And whereas the Council of the City of Kew hereby resolve that the right of way abutting Nos. 126 to 142 (Lots 26 to 34) Harp Road and Nos. 39 to 57 (Lots 48 and 40) First Avenue, Kew be discontinued and not less than one month previously has published a public notice in a newspaper generally circulating in the municipal district and has given written notice to the last registered owner of the land in the road and the owners and occupiers of lands abutting or immediately adjacent to the road of the intention to make this Resolution and has received no written objections within fourteen (14) days of the publication of the public notice as aforesaid.

Now therefore the Council of the City of Kew hereby directs—

- (a) that the said road which is shown by hatching on the plan herewith shall be discontinued upon publication of this resolution in the *Government Gazette*,

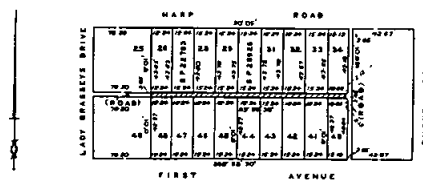

- (b) that notwithstanding such discontinuance the Melbourne and Metropolitan Board of Works shall continue to have and possess the same right title power authority or interest in or in relation to the whole of the land shown by hatching on the said plan as it had or possessed prior to such discontinuance with respect to or in connection with any drains or pipes laid or erected in on or over such land for the purposes of drainage, sewerage or for the supply of water;
- (c) that notwithstanding such discontinuance the City of Kew shall continue to have and possess the same right title power authority or interest in or in relation to the whole of the land shown by hatching on the said plan as it had or possessed prior to such discontinuance with respect to or in connection with any drains or pipes laid or erected in or over such land for the purposes of drainage;
- (d) that subject to any such right title power authority or interest the land in the said road shall vest in the municipality to be retained by it until it is sold by private treaty.

3466 ADRIAN HALLIDAY, Chief Executive

#### CITY OF MILDURA

##### Confirmation of By-Law

##### Building By-Law 54

In accordance with the provisions of sections 189 and 204 of the *Local Government Act 1958*, the Mildura City Council, at its ordinary meeting held on Thursday, 26 June 1986 confirmed By-law Number 54 entitled "The Building By-Law" made by the council at its meeting held on 22 May 1986. The purpose of the By-law is to regulate the erection, construction and alteration of any buildings within the municipal district and a copy of the By-law is available for inspection without fee by any person during office hours at the Civic Buildings, Deakin Avenue, Mildura.

This By-law will come into operation as and from 10 July 1986.

DAMIAN B. GOSS

3468

Town Clerk and Chief Executive

**CITY OF MILDURA**  
Vesting of Reserve

Recreation Reserve located on the eastern side of Kaita Drive opposite Nonda Close and more commonly known as Kaita Park.

The Council of the City of Mildura in accordance with the provisions of Section 569BA (1) of the *Local Government Act 1958*, the provisions of such section having been complied with at its meeting held 26 June 1986 resolved and directed that the Recreation Reserve on Plan of Subdivision No. 138574 Parish of Mildura County of Karkaroc and located on the eastern side of Kaita Drive opposite Nonda Close and more commonly known as Kiata Park, as shown hatched on the plan hereunder, be vested in the name of the Mayor, Councillors and Citizens of the City of Mildura and by this resolution such land in the Reserve shall so vest free and discharged of any mortgage, charge, lease or sub-lease.

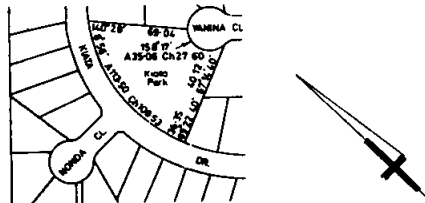

3467 **DAMIAN B. GOSS,**  
Town Clerk and Chief Executive

**CITY OF MORDIALLOC**  
Road Discontinuance

That pursuant to section 528 (2) of the *Local Government Act 1958* the Council of the City of Mordialloc not less than one month after publishing a public notice in a newspaper generally circulating in the municipal district and given written notice to the registered proprietor of the land and owners and occupiers of any land abutting or immediately adjacent to the road of its intention to discontinue part of the right-of-way from the Centreway and the whole of the right-of-way from Main Street and having heard and considered all written objections direct by resolution on 17 December 1984 as follows:

- (a) That part of the right-of-way from the Centreway shown double hatched on the attached plan be discontinued upon publication of this resolution in the *Government Gazette*.
- (b) That the right-of-way abutting 600-604 Main Street shown hatched on the attached plan be discontinued upon publication of this resolution in the *Government Gazette*.
- (c) That the land in the said road shall vest in the municipality to be retained by it until it is sold by private treaty.

- (d) That notwithstanding such discontinuance the Melbourne and Metropolitan Board of Works shall continue to have and possess the same right, title, power, authority or interest in or in relation to the whole of the land shown by double hatching on the said plan as it had or possessed prior to such discontinuance with respect to or in connection with any drains or pipes laid or erected in, on or over such land for the purposes of drainage or sewerage.

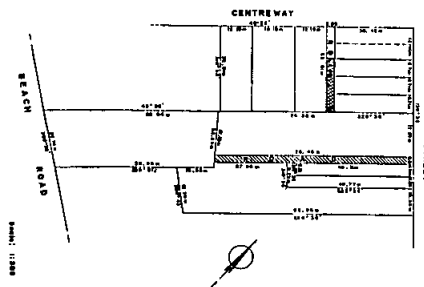

3484 **D. H. CORBEN**  
Town Clerk and City Manager

**CITY OF SOUTH MELBOURNE**  
Declaration of Land as a Public Highway

Pursuant to section 522 of the *Local Government Act 1958*, the Council of the City of South Melbourne hereby directs that part of the land contained in Certificate of Title Volume 9622 Folio 748 and indicated by the continuous lines on the accompanying diagram which has been acquired by the council, shall be a public highway on and from the date of publication of this order in the *Government Gazette*.

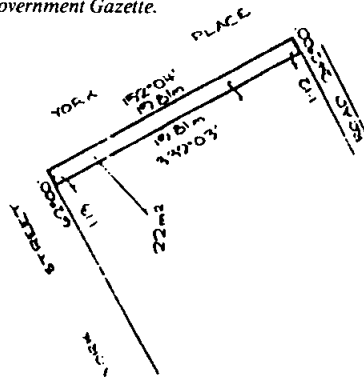

3485 **NOEL F. KROPP**  
Chief Executive Officer and Town Clerk

**CITY OF SPRINGVALE**

**Road (Right of Way) Discontinuance**

Pursuant to section 528 (2) of the *Local Government Act 1958* (as amended) the Council of the City of Springvale, after consultation with public authorities and the advertising of its intention and notification to the registered proprietors of the land and the owners and occupiers of any land abutting or immediately adjacent to the road, has by Resolution at its ordinary meeting, held on 23 June 1986, resolved that the road at the rear of Allotment Nos. 23/36 Sixth Avenue and Allotment Nos. 73-85 and 22 Fifth Avenue, Chelsea Heights, contained in Certificate of Title Volume 3681 Folio No. 029 as shown hatched on the plan hereunder be discontinued and sold by private treaty.

Notwithstanding such discontinuance the City of Springvale and the M.M.B.W. shall continue to have and possess the same right, title, power, authority or interest in or in relation to the whole of the land shown hatched.

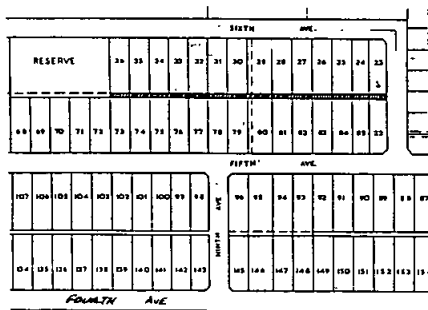

3469 I. J. TATTERSON, Chief Executive Officer

**CITY OF SPRINGVALE**

**Road (Right of Way) Discontinuance**

Pursuant to section 528 (2) of the *Local Government Act 1958* (as amended) the Council of the City of Springvale, after consultation with public authorities and the advertising of its intention and notification to the registered proprietors of the land and the owners and occupiers of any land abutting or immediately adjacent to the road, has by Resolution at its ordinary meeting, held on 23 June 1986, resolved that the road at the rear of Allotment Nos. 168-178 Fourth Avenue and 179-189 Third Avenue, Chelsea Heights, contained in Certificate of Title Volume 3681 Folio No. 029 as shown hatched on the plan hereunder be discontinued and sold by private treaty with the exception of that part of the road at the rear of Allotment Nos. 170-173 Fourth Avenue, Chelsea Heights which will be retained by the City of Springvale for municipal purposes.

Notwithstanding such discontinuance the City of Springvale and the M.M.B.W. shall continue to have and possess the same right, title, power, authority or interest in or in relation to the whole of the land shown hatched.

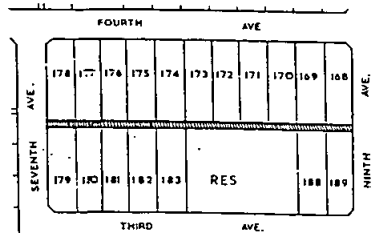

3470 I. J. TATTERSON, Chief Executive Officer

**CITY OF ST. KILDA**

**By-Law No. 212**

**Open Air Burning and Incinerator By-Law**

Notice is hereby given in pursuance of the powers conferred by the *Local Government Act 1958*, the Council of the City of St. Kilda has made a By-law Number 212 for the purposes of—

- (a) regulating the times during which incinerators may be used on property used wholly or partly for residential purposes;
- (b) suppressing nuisances;
- (c) preventing and extinguishing fires.

The By-law includes provisions relating to the location of and the hours and days on which incinerators may be burned. Clause 15 of the said By-law No. 212, advertised in the *Government Gazette* No. 9 dated 12 February 1986, is hereby amended with the following:

"15. Notwithstanding any other provisions of this By-law to the contrary no person shall light or allow to be lit or to remain alight any fire in an incinerator on any residential premises—

- (1) on any Sunday; and
- (2) on any Monday; and
- (3) on any other day except between the hours of 10.00 a.m. and 3.00 p.m."

A resolution approving the By-law was carried at a meeting of Council held on 22 July 1985, and confirmed at a meeting of the Council held on 19 August 1985.

3455 BRIAN JONES, City Manager

**SHIRE OF BULN BULN**

**Vesting of Reserves**

Notice is hereby given that the Reserves listed below, are vested in Council, freed and discharged from any mortgage, charge, lease or sub-lease, pursuant to section 569BA (1) of the *Local Government Act 1958* in accordance with Council's resolution of 23 June 1986:

1. The Boeyen Park Reserve on Plan of Subdivision No. 77255 lodged in the Office of Titles;

2. The Recreation Purposes Reserve coloured green on Plan of Subdivision No. 96679 lodged in the Office of Titles;

3. The Park Reserve on Plan of Subdivision No. 99090 lodged in the Office of Titles;

4. The Recreation, Drainage and Sewerage Reserve on Plan of Subdivision No. 88767 lodged in the Office of Titles;

5. The Park Reserve coloured green on Plan of Subdivision No. 112485 lodged in the Office of Titles;

6. The Park Reserve on Plan of Subdivision No. 117568 lodged in the Office of Titles;

7. The Drainage and Tree Reserve, and the Drainage and Recreation Reserve on Plan of Subdivision No. 118593 lodged in the Office of Titles;

8. The Park Reserve on Plan of Subdivision No. 122994 lodged in the Office of Titles;

9. The Reserve for recreation purposes on Plan of Subdivision No. 135261 lodged in the Office of Titles;

10. The Drainage, Sewerage and Recreation Reserves (2) on Plan of Subdivision No. 135360 lodged in the Office of Titles;

11. The Drainage, Sewerage and Recreation Reserve on Plan of Subdivision No. 135795 lodged in the Office of Titles;

12. The Public Recreation Reserve and the Recreation, Drainage Sewerage Reserve on Plan of Subdivision No. 138945 lodged in the Office of Titles;

13. The Recreation Purposes Reserve on Plan of Subdivision No. 139080 lodged in the Office of Titles;

14. The Drainage and Recreation Reserve on Plan of Subdivision No. 139179 lodged in the Office of Titles;

15. The Recreation Reserve on Plan of Subdivision No. 141102 lodged in the Office of Titles;

16. The Reserve for Municipal Purposes on Plan of Subdivision No. 136660 lodged in the Office of Titles;

17. The Park Reserve for recreation purposes on Plan of Subdivision No. 114238 lodged in the Office of Titles.

*Town and Country Planning Act 1961*  
SHIRE OF KILMORE PLANNING SCHEME  
1973

Notice that a Planning Scheme has been Prepared and is Available for Inspection

Amendment No. 65, 1986

Notice is hereby given that the Shire of Kilmore, in pursuance of its powers under the *Town and Country Planning Act 1961* (as amended) has prepared a Planning Scheme for land known as Crown Allotment 60E, Parish of Bylands, Anderson Road, Kilmore. The purpose of the Scheme is to rezone the said land from its present zoning of Rural A1 to Residential Development Zone.

A copy of the said Scheme has been deposited at the office of the Shire of Kilmore, Civic Centre, Sydney Street, Kilmore and at the office of the Ministry for Planning and Environment, The Olderfleet Buildings, 477 Collins Street, Melbourne and will be open for inspection during office hours by any person free of charge.

Any persons affected by the Planning Scheme are required to set forth in writing all objections they may have addressed to the Shire Secretary, Shire of Kilmore, P.O. Box 187, Kilmore, 3764 on or before 11 August 1986 and to state whether they wish to be heard in respect to their objections.

Dated 9 July 1986

3501 T. K. HAYES, Shire Secretary

*Town and Country Planning Act 1961*  
SHIRE OF KILMORE PLANNING SCHEME  
1973

Notice that a Planning Scheme has been Prepared and is Available for Inspection

Amendment No. 66, 1986

Notice is hereby given that the Shire of Kilmore, in pursuance of its powers under the *Town and Country Planning Act 1961* (as amended), has prepared a Planning Scheme for land known as Crown Allotments 2, 3, 4, 5, 6, 10, 11, 12 and 13, Section 30 and Crown Allotments 1, 2, 3 and 4, Section 31, Township of Wallan, Parish of Wallan Wallan, Watsons and Queen Streets, Wallan. The purpose of the Scheme is to rezone the said land from its present zoning of Rural A2 to Residential Development zone.

A copy of the said Scheme has been deposited at the office of the Shire of Kilmore, Civic Centre, Sydney Street, Kilmore and at the office of the Ministry for Planning and Environment, The Olderfleet Buildings, 477 Collins Street, Melbourne and will be open for inspection during office hours by any person free of charge.

Any persons affected by the Planning Scheme are required to set forth in writing all objections they may have addressed to the Shire Secretary, Shire of Kilmore, P.O. Box 187, Kilmore, 3764 on or before

11 August 1986 and to state whether they wish to be heard in respect to their objections.

Dated 9 July 1986

3502 T. K. HAYES, Shire Secretary

Form 2.1

*Town and Country Planning Act 1961*  
SHIRE OF FLINDERS PLANNING SCHEME  
1962

Notice that a Planning Scheme has been Prepared and is Available for Inspection

Amendment No. 202, 1986

Notice is hereby given that the Council of the Shire of Flinders in pursuance of its powers under the *Town and Country Planning Act 1961* has prepared a scheme to amend the Planning Scheme Ordinance to include the use of "Concerts" in Column 4 or Column 5 within the various Conservation Plan Zones.

A copy of the amendment has been deposited at the office of the Shire of Flinders, Boneo Road, Rosebud, and at the office of the Ministry for Planning and Environment, The Olderfleet Buildings, 477 Collins Street, Melbourne, and will be open for inspection during office hours by any person free of charge.

Any persons affected by the amendment are required to set forth in writing any submission they may wish to make with respect to the amendment addressed to The Chief Executive, Shire of Flinders, P.O. Box 1000, Rosebud 3939 by 13 August 1986 and state whether you wish to be heard in respect of your submission.

3434 H. THOMSON, Senior Planning Officer

*Town and Country Planning Act 1961*  
SHIRE OF KILMORE PLANNING SCHEME  
1973

Notice that a Planning Scheme has been Prepared and is Available for Inspection

Amendment No. 63, 1986

Notice is hereby given that the Shire of Kilmore, in pursuance of its powers under the *Town and Country Planning Act 1961* (as amended), has prepared a Planning Scheme for land known as the Extension of the State School Reserve, Section 14, Township of Wallan, Parish of Wallan Wallan, Queen Street, Wallan. The purpose of the Scheme is to rezone the said land from its present Reservation of Existing Public Purposes—Education Department to Residential Zone.

A copy of the said Scheme has been deposited at the office of the Shire of Kilmore, Civic Centre, Sydney Street, Kilmore and at the office of the Ministry for Planning and Environment, The Olderfleet Buildings, 477 Collins Street, Melbourne and will be open for inspection during office hours by any person free of charge.

Any persons affected by the Planning Scheme are required to set forth in writing all objections they may have addressed to the Shire Secretary, Shire of Kilmore, P.O. Box 187, Kilmore, 3764 on or before 9 October 1986 and to state whether they wish to be heard in respect to their objections.

Dated 9 July 1986

3500 T. K. HAYES, Shire Secretary

Form 2.1

*Town and Country Planning Act 1961*  
SHIRE OF MILDURA INTERIM  
DEVELOPMENT ORDER No. 5/1981

Notice that an Amendment has been Prepared and is Available for Inspection

Amendment No. 15

Notice is hereby given that the Council of the Shire of Mildura in pursuance of its powers under the *Town and Country Planning Act 1961* has prepared an amendment to its Interim Development Order No. 5/1981 for the creation of an Industrial Zone and the rezoning of 60 acres of land in Koorlong Avenue, Irymple being Crown allotments 5, 6 and 7, section 42, and Crown allotments 15, 16 and 17, section 43, Block F, Parish of Mildura for industrial development.

A copy of the amendment has been deposited at the office of the Ministry for Planning and Environment, The Olderfleet Buildings, 477 Collins Street, Melbourne and at the Shire Offices, 15th Street, Irymple, and will be available for inspection during office hours by any person free of charge.

Any persons affected by the amendment are required to set forth in writing any submission they may wish to make with respect to the amendment addressed to the Shire Secretary, Shire of Mildura, P.O. Box 366, Irymple, 3498, by 11 August 1986 and state whether they wish to be heard in respect of the amendment.

Dated 9 July 1986

3486 DAVID J. McMILLAN, Shire Secretary

SHIRE OF RUTHERGLEN

Discontinuance of Roads

Take notice that in accordance with the provisions of the *Local Government Act 1958*, the Council of the Shire of Rutherglen on 18 June 1986, resolved:

- (a) That the portion of private lane abutting Lots 42-60 and 61-75 on P/S3881 shown as hatched on the plan hereunder is not required for public purpose.
- (b) That the said portion of the road be discontinued and upon publication of the resolution in the *Government Gazette*, the said road portion shall be deemed to be discontinued and the land being the said road portion shall vest in the Municipality until sold by private treaty to the abutting owners.

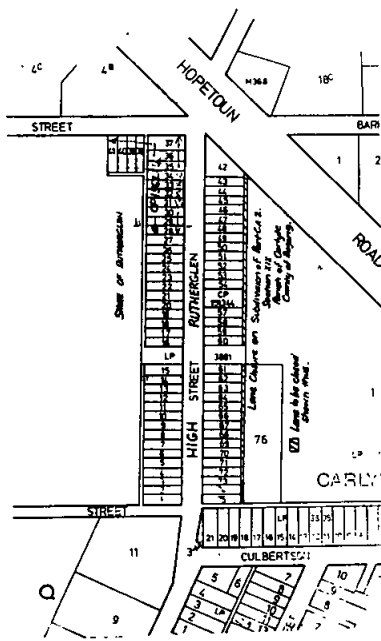

3503 WALTER J. McQUILLEN, Shire Secretary

*Town and Country Planning Act 1961*  
**SHIRE OF SHERBROOKE PLANNING  
 SCHEME 1979 (URBAN AREAS)**

Notice that a Planning Scheme has been Prepared  
 and is Available for Inspection  
 Amendment No. 46

Notice is hereby given that the Shire of Sherbrooke in pursuance of its powers under the *Town and Country Planning Act 1961* has prepared a scheme for the purpose of modifying the Restructure Plan on Page 48 of the Ordinance to delineate Lots 49-56, L.P. 9210 Nation Road-Charles Street, Selby as two Restructure Lots.

A copy of the scheme has been deposited at the Shire Offices, Glenfern Road, Upwey and at the Office of the Ministry for Planning and Environment, The Olderfleet Buildings, 477 Collins Street, Melbourne and will be open for inspection during office hours by any person free of charge.

Any persons affected by the Scheme are required to set forth in writing any submissions they may wish to make with respect to the scheme, addressed to the Shire Secretary, Shire of Sherbrooke, Glenfern Road, Upwey by 9 August 1986 and state whether they wish to be heard in respect of their submission.

K. E. MATSON  
 3504 General Manager and Shire Secretary

**MITCHELL WATER BOARD**  
**Paynesville Sewerage District**  
 General Notice

The Mitchell Water Board having made provision for carrying off the sewage from each and every property which or any part of which is within the sewerage area hereinafter described doth hereby declare that on and after 1 July 1986, each and every property which or part of which is within the said sewerage area shall be deemed to be a seweraged property within the meaning of the *Sewerage Districts Act 1958*.

*Declared Area No. 2*

The boundaries of the sewerage area hereinafter referred to are shown on the declared area plan at the Board's office, 2 Nicholson Street, Bairnsdale. A copy of the plan is also available at the Board's Paynesville site office, 3 Ashley Street, Paynesville.

R. J. COMBEN, Chairman  
 D. J. ROBERTS, Secretary  
 3435

**PORTLAND WATER BOARD**

**Commencement of Works, Hamiltons Dairy  
 Subdivision, Stage 1—Reticulation Extension**

Notice is hereby given that the Board intends to construct sewers in the area of West Portland, which is generally bounded by Lalor and Park Streets and Kerrs Road.

Plans showing details of the proposed works to be carried out are available for inspection at the Board Offices, Town Hall, Portland, during normal working hours.

P. K. SHANAHAN, Town Clerk  
 3437

**PORTLAND WATER BOARD**

**Commencement of Works, Diel Atlantis  
 Subdivision, Stage 1—Reticulation Extension**

Notice is hereby given that the Board intends to construct sewers in the area of South Portland, which is generally bounded by Edgar Street, Grevillia Court and West Boundary Road.

Plans showing details of the proposed works to be carried out are available for inspection at the Board Offices, Town Hall, Portland, during normal working hours.

P. K. SHANAHAN, Town Clerk  
 3436

**DANDENONG VALLEY AUTHORITY**

**Declaration of Arterial Drains**

The Dandenong Valley Authority, in pursuance and exercise of the powers conferred by the *Dandenong Valley Authority Act 1963*, doth hereby declare that the rivers, creeks, watercourses and drains, and new arterial drains proposed within the district of the Authority as set out and described in the Schedule hereto, shall be arterial drains under and for the purposes of the Act.



## SCHEDULE

Declaration of Arterial Drains  
New Declarations

## Quirks Creek No. 1401B

Commencing at a point on the north side of Brown Road Officer within the Shire of Pakenham approximately mid-way along the north boundary of Crown Allotment 51 Parish of Pakenham then generally south through CA. 51 to and across Peck Road at a point approximately mid-way along the north boundary of CA.44 then generally southerly to its junction with the existing declared Quirks Creek No. 6210.

## Gum Scrub Creek No. 1402ABC

Commencing at a point on the north side of Brown Road Officer within the Shire of Pakenham approximately 350 metres east of Officer-Upper Beaconsfield Road then south across Brown Road then generally south through Crown Allotment 42 Parish of Pakenham to the north side of Princes Highway approximately mid-way along the southern boundary of CA. 42 then south across the Princes Highway then generally southwest through CA. 16 to the southwest corner of CA. 16 then generally southeast through CA.'s 18, 19 and 20 to a point on the northern side of Leckey Road near the southeast corner of CA. 20 then south across Leckey Road then generally southeasterly through CA. 8 to a point approximately mid-way along the south boundary of CA. 8 then generally south through CA.'s 3 and 3A to a point on the northern boundary of the Koo-wee-rup Flood Protection District opposite a point approximately mid-way along the southern boundary of CA. 3A Patterson Road Officer.

## Gum Scrub Creek No. 1403A

Commencing at a point on the northern side of Officer-Upper Beaconsfield Road Officer within the Shire of Pakenham approximately 250 metres west of Godfrey Lane then southerly across Officer-Upper Beaconsfield Road then south through the northwest corner of Crown Allotment 235 Parish of Pakenham then generally south to a point approximately mid-way along the north boundary of CA.154 then generally south through CA.154 then continuing southerly through CA.149 and the water reserve on the northeast corner of Officer-Upper Beaconsfield Road and Brown Road to its junction with the Gum Scrub Creek No. 1402A.

## Haunted Gully Creek No. 1404ABC

Commencing at a point on the south side of the Beaconsfield Reservoir then generally south east to and across Payne Road approximately 250 metres east of Haunted Gully Road Officer within the Shire of Pakenham then generally southeast to and across Dickie Road within Crown Allotment 145 Parish of Pakenham then further southeast through CA. 145 to a point near northwest corner of CA. 147 then southeasterly through CA. 147 to and across Officer-Upper Beaconsfield Road then generally southeast to its junction with the Gum Scrub Creek No. 1402A.

## Cardinia Road Drain No. 1502B

Commencing at a point on the eastern side of Cardinia Road Pakenham within the Shire of Pakenham at its junction with the existing declared Cardinia Road drain No. 6320 then generally southeast through Crown Allotment 7c, the channel reserve and Crown Allotments 6A, 6c and 5 Parish of Pakenham to its junction with the Koo-wee-rup Flood Protection District on Watson Road Pakenham.

## Pakenham Creek No. 1602AB

Commencing at a point on the north side of Crown Allotment 1 Parish of Nar Nar Goon approximately 250 metres west of Healesville/Koo-wee-rup Road Pakenham within the Shire of Pakenham then southerly through CA.'s 1, 2 and 3 to and across Healesville/Koo-wee-rup Road then continuing south through CA. 34 Township of Pakenham and CA. 8 Parish of Nar Nar Goon to the north side of the Princes Highway and its junction with the existing declared Pakenham Creek No. 6500.

## Eastern Drain No. 1603B

Commencing at a point on the north side of the Princes Highway Pakenham within the Shire of Pakenham approximately 600 metres east of the original Army Road reserve then southerly through CA. 40 Parish of Nar Nar Goon to a point near the northwest corner of CA. 37A then continuing southerly through CA.'s 37A, 37B, 36A and 36B to its junction with the existing declared Deep Creek No. 6400.

## Kennedy Creek No. 1604A

Commencing at a point approximately mid-way along the northern boundary of Crown Allotment 5B Parish of Nar Nar Goon within the Shire of Pakenham then southerly through CA.'s 5B, 5A, 4 and 6 to its junction with the existing declared Kennedy Creek No. 6600.

## Deep Creek No. 1607ABC

Commencing at a point approximately mid-way along the northern boundary of Crown Allotment 17G Parish of Nar Nar Goon within the Shire of Pakenham then southwest through CA. 17G and 17N then south through CA. 5G then south east through CA. 5D to and across Gordon Road then continuing southeast through CA. 17H and 17D to the northwest corner of CA. 18A then southerly along the west boundaries of CA's 18A and 20 to the north boundary of the Princes Highway and its junction with the existing declared Deep Creek No. 6400.

## McDonald Drain Road No. 1700AB

Commencing at a point on the north side of Bald Hill Road Nar Nar Goon within the Shire of Pakenham approximately 300 metres east of McDonald Drain Road then south across Bald Hill Road then continuing south through Crown Allotments 28 and 29 Parish of Nar Nar Goon to and across Bourke Road then south through CA. 69A to the boundary of the Koo-wee-rup Flood Protection District.

**Hancocks Gully Drain No. 1700CDEF**

Commencing at a point on the north side of Seymour Road approximately 800 metres east of Dore Road within the Shire of Pakenham then south through Crown Allotments 19 and 21 Parish of Nar Nar Goon to and across the Princes Highway then southerly through CA.'s 62, 65, 66A and 66B to and across the Gippsland Railway approximately 300 metres west of Mount Ararat Road then south through CA.'s 69 and 70 then further south and east through CA. 72 to and across Bald Hill Road approximately 1000 metres west of Mount Ararat Road then southerly through CA.'s 75D and 75C to and across Bourke Road then south through CA.70A to the boundary of the Koo-wee-rup Flood Protection District.

**Mount Ararat Drain No. 1700GH**

Commencing at a point on the north side of the Gippsland Railway approximately 800 metres east of Mount Ararat Road within the Shire of Pakenham then south through Crown Allotments 67, 68, 79A and 78A Parish of Pakenham to and across Bald Hill Road approximately 600 metres east of Five Mile Road then south west through CA.76A to and across Five Mile Road near the northeast corner of CA. 75G then further southwest through CA.75G to and across Bourke Road west of Five Mile Road then south through CA.71A to the boundary of the Koo-wee-rup Flood Protection District. 3535

**Sewerage Districts Act 1958****DECLARATION OF SEWERED AREA  
Woodend Water Board**

The Woodend Water Board which has made provision for the carrying off of sewage from each and every property which or any part of which is within Sewerage Area Number 1 described below, declares that on and after 1 July 1986, each and every property which or any part of which is within the sewerage area shall be deemed to be a sewered property within the meaning of the *Sewerage Districts Act 1958*.

The general boundary of Sewerage Area No. 1 is:

The east side of Schaw Street; the rear boundaries of properties fronting the west side of Jeffery Street except the Woodend Racecourse Reserve; Five Mile Creek between Jeffery Street and Pyke Street; the west side of Pyke Street to Anslow Street; the rear boundaries of allotments fronting the east side of Templeton Street; the east and northern boundaries of property No. 47, Urquhart Street; the northern boundary of property No. 46 Urquhart Street; the northern and eastern boundaries of property No. 15, Brooke Street; the southern side of Brooke Street to Wood Street; the western side of Wood Street from Brooke Street to Bawdon Road; the northern side of Bawdon Road from Wood Street to High Street; the eastern, southern and western boundaries of the railway station area (excluding the house property fronting Corinella Road) to Schaw Street.

A map showing the boundaries of Sewerage Area Number 1 is available for inspection between the hours of 8.30 a.m. and 4.30 p.m., Monday to Friday, at the Board's Offices, 92 High Street, Woodend.

Br Order of the Woodend Water Board

GEORGE CRANBY,

Chairman

DAN DREW

Secretary

3536

**WESTERNPORT WATER BOARD**

Notices to owners of tenements in the under-mentioned streets, lanes, courts and alleys opening thereto. The main pipe in the said streets being laid down, the owners of all tenements situated as under are hereby required on or before 1 July 1986 to cause a proper pipe and stop cocks to be laid so as to supply water within tenements from the main pipe:

The Esplanade, Surf Beach—Lots 218 to 240.

Kennon Court, Cowes—Lots 18 to 20.

Beresford Drive, Woolamai Waters—Lots 365 to 368.

Sunderland Bay Road and Gemma Street—Lots 61 to 64, 51, and 66 to 70.

Sidford Street, Ventnor—Lots 20, 21, 38 and 39.

Walker Street, Dalyston—Lot 5.

3471

**SUNBURY WATER BOARD**

Notice is hereby given that the above Authority intends to construct sewers and related works in the area known as Diggers Rest Township to serve properties situated in the whole or parts of the areas hereinafter described in the Sunbury Sewerage District.

Maps and plans showing the works to be constructed are open for inspection at the Board's office, between the hours of 9.00 a.m. and 5.00 p.m., Monday to Friday.

The area referred to above comprises the area generally bounded by Plumpton Road, Calder Highway and Commonwealth Army Camp.

3505 JOHN M. KELLY, Secretary

Notice is hereby given that the partnership between Shane Patrick Baker and Dorothy Ann Baker formerly carrying on the business of Automotive Repairers under the name of BMK Automotive at 15 Rutland Street, Newtown has been dissolved with effect from 18 June 1986 and notice is further given that the said Shane Patrick Baker will thereafter carry on the said business at the said address under the said name.

All debts due and owing by the said firm will be received and paid by the said Shane Patrick Baker at the said address.

Dated 3 July 1986

SHANE PATRICK BAKER

DOROTHY ANN BAKER

3543

Take notice that the Partnership between D. J. Bennett Holdings Pty. Ltd. and Leeannedale Holdings Pty. Ltd. and Kenall Nominees Pty. Ltd. under Partnership Agreement dated 22 July 1983 is dissolved as of 30 June 1986. 3510

As of 30 June 1986 the partnership of Senia, Pegg & Associates will be dissolved.

Andrew Senia will continue to practice under the name of Andrew Senia & Associates, 94 Gheringhap Street, Geelong, 3220 (Phone: 052 216788).

Murray Pegg will continue to practice under the name of Murray Pegg & Associates, 3rd Floor, State Bank, 123 Ryrie Street, Geelong, 3220 (Phone 052 222935). 3508

Notice is hereby given that the Partnership heretoforth subsisting between Rodney Peacock, and Marilyn Peacock as trustees of the Rodney Peacock Family Estate and Lester Rickard and Betty Rickard and carrying on Business at 6 Hay Avenue, Wangaratta in Victoria, under the name of Wangaratta Paint & Panel has been dissolved as from 30 June 1986.

CONNELL, McKENNA & WEARNE solicitors of 117 Murphy Street, Wangaratta 3542

Notice is hereby given that the partnership heretofore subsisting between Robert George Peters and Geoffrey Edward Victor Fairbrass carrying on business as builders at Flat 3, 105 Gertrude Street, Geelong West under the style or firm of "G. & G. Constructions" has been dissolved as from 30 June 1986.

Dated 30 June 1986

ROBERT GEORGE PETERS  
GEOFFREY EDWARD VICTOR FAIRBRASS  
3511

Notice is hereby given that the Partnership between George Christian Jacobsen and Ronald Neil McKenzie, carrying on business as Drouin West Berry Farm at Lot 8, Fishers Road, Drouin West was dissolved on 30 June 1986. 3512

Notice is hereby given that the partnership heretofore existing between Graeme Axton Hallam, William Philip Watson, Neil Kenneth Wright and John Graeme McLean carrying on business as Chartered Accountants under the firm name of Morton Watson Young & McLeans at 10 Queens Road, Melbourne and corner of Scott and Thomas Streets, Dandenong has been dissolved by mutual consent as from 30 June 1986.

Dated 3 July 1986

3527

W. P. WATSON

Notice is hereby given that the partnership of Janet Christine Bailey and Sandra Lorraine Bailey carrying on business as Mordialloc Plaza Boutique at Shop 6, Mordialloc Plaza, 606 Main Street, Mordialloc has been dissolved as from 27 June 1986. All debts due and owing by the said partnership will be received and paid respectively by Janet Christine Bailey who will continue to carry on the said business. 3528

T. P. SMITH & SON CARTAGE  
CONTRACTORS

140 Mary Street, Richmond

Take notice that Stephen James Smith of the above address retired from the above partnership business on 30 June 1986 and from that date Mark Gordon Smith and Jacqueline Smith were admitted into the partnership by Gordon James Smith and Linda Mary Smith. 3473

Notice is hereby given that the partnership heretofore subsisting between Ann Williams and Dennis Bartlett carrying on business as transport/courier contractors at 91 Carinish Road, Clayton in the State of Victoria under the firm name of Strate-Thru Transport has been dissolved as from 31 May 1985.

EGAN LOBB & WALKER, solicitors, 5  
Hamilton Place, Mount Waverley 3474

Notice is hereby given that the partnership heretofore subsisting between us the undersigned carrying on business as Rotary Hoers at Mt. Waverley and Mulgrave under the style or firm of J. P. Rotary Hoeing and Garden Services has been dissolved by mutual consent on 30 June 1986 so far as concerns Peter Rennie who retires from the said firm. John Reilly shall continue in his own name the business formerly carried on by the partnership.

PETER RENNIE  
JOHN REILLY  
3439

Companies (Victoria) Code  
ROY KNORR PTY. LTD.  
(in Voluntary Liquidation)

Notice is hereby given that at an extraordinary general meeting of the members of the abovenamed company, held at the offices of Johnson Barson Services Pty., 901 Whitehorse Road, Box Hill on 1 July 1986 the following special resolution was passed.

"That steps be taken to conduct a members' voluntary winding up and that Mr John Barson, chartered accountant, c/o Johnson Barson Services Pty., 901 Whitehorse Road, Box Hill is hereby appointed liquidator."

Dated 1 July 1986

3487

JOHN BARSON, Liquidator

## Unclaimed Moneys Act 1962

## Register of Unclaimed Moneys held by the—

<i>Name of Owner on Books and Last Known Address</i>	<i>Total Amount Due to Owner</i>	<i>Description of Unclaimed Money</i>	<i>Date when Amount first became Payable</i>
\$			
SOUTHERN CROSS TV8			
Black, Myrtle Louisa, c/o 15 Stonehaven Ave, Boronia	22.35	Dividends	—4.82
Caerdon Canberra Pty Ltd, A W Aitchison, 66 King St, Sydney, NSW	10.28	"	"
Duncan, David	21.60	"	"
Goodall, Lorna A, 198 Timor St, Warrnambool	21.60	"	"
Hawkins, Robert R, 77 Buckingham Dve, Heidelberg	30.53	"	"
Mansfield, June B	10.05	"	"
Mitchell, Noreen O	30.53	"	"
Powell, Nellie M	107.63	"	"
Reade, Margaret L, 47 Antrim St, East Ballina, NSW	30.53	"	"
Anderson, Kenneth B, 28 Devon St, Eaglemont	26.51	"	—11.82
Bear, Phleta A, 7 Conto Ave, Dianella, WA	23.32	"	"
Caerdon Canberra Pty Ltd, c/o A W Aitchison, 66 King St, Sydney, NSW	18.04	"	"
Duncan, David	38.06	"	"
Czydel, Janina, 125 Tambat St, East Bentleigh	97.90	"	"
Fox, Mabel B, c/o PO, Guildford	26.51	"	"
Favaloro, Kathleen, c/o J Paine, 20 McCracken Ave, Donald	26.84	"	"
Goodall, Loran A, 198 Timor St, Warrnambool	26.51	"	"
Hickey, Andrew	15.40	"	"
Mansfield, June B	17.71	"	"
Powell, Nellie M	189.42	"	"
Burns, Jean D, 99 Sternberg St, Bendigo	73.43	"	—4.83
Caerdon Canberra Pty Ltd, c/o A W Aitchison, 66 King St, Sydney, NSW	12.30	"	"
Duncan, David	25.95	"	"
Hickley, Andrew	10.50	"	"
Mansfield, June B	12.08	"	"
Powell, Nellie M	129.15	"	"
3449			

## NOBLE KNIGHT &amp; CO PTY LTD

Clarke, L M	25.00	Cheque	13.9.84
3448			

## GENERAL MOTORS—HOLDEN'S LTD DANDENONG

Arnott, T, 1 Logie Crt, Oakleigh	91.92	Wages	—4.84
Rallakis, I, 68/510 Lygon St, Carlton	16.40	W/Comp.	"
Bell, C F, 31 Floriana Ave, Doveton	137.52	Wages	—6.84
Bochenski, H, 44 Virginia St, Springvale	53.44	"	"
Steele, J, 1 Nives Crt, East Burwood	258.00	Hol. Pay	—8.84
Rafferty, G P, 56 Power Rd, Doveton	79.97	Wages	—11.84
Chiam, T E, 10 Cantala St, Clayton	52.24	"	—12.84
Donovan, A D, 178 Bedford Rd, Croydon	48.82	"	—1.85
Chao, M, 1/49 Princes Hwy, Springvale	90.33	"	"
Nguyen, V N, 2/30 Kelvinside Rd, Noble Park	87.24	"	—3.85
3447			

## Unclaimed Moneys Act 1962

## Register of Unclaimed Moneys held by the—

<i>Name of Owner on Books and Last Known Address</i>	<i>Total Amount Due to Owner</i>	<i>Description of Unclaimed Money</i>	<i>Date when Amount first became Payable</i>
\$			
RHEEM AUSTRALIA LIMITED			
Dunlop, Gladys V, 4/380 St Kilda St, Brighton	40.74	Dividend	1.3.85
Holdenson, Harvey R (estate of), c/o James A Murray, GPO Box 2282u, Melbourne	98.00	"	"
Benson, Melissa, A/c Marta Lazarus, PO Box 291, Ashfield, NSW	52.64	"	18.9.84
Lesue, Neil G, 87 Hardie St, Mascot, NSW	169.40	"	1.3.85
McMahon, Elsie M, 31A Murdoch St, Cremorne, NSW	90.19	"	18.9.94
Moore, Alan U, 35 York St, Dundas, NSW	98.00	"	1.3.85
Perks, Sophie, 28/27 Herbert St, St Kilda	43.47	"	"
Rose, Michael and Mark, 21 Lydia St, Bentleigh	10.57	"	"
Schofield, Thomas W (estate of), c/o Dermott Sarah & Co, 183 Macquarie St, Sydney, NSW	227.50	"	18.9.84
3451			
COLES-MYER LTD			
Allen, Edward H (estate of), c/o Kneale & Co, 10 Hill St, Douglas, Isle of Man	119.00	Dividend	13.10.84
Allen, Elizabeth S, c/o Barclays Bank Limited, 75 Wimbledon High St, London, UK	18.36	"	"
Anderson, Alfred M Jnr, 26 Theale Tce, Ashgrove, Qld	13.20	"	"
Anderson, Anne, "Waterford", No. 6 RD, Ashburton, NZ	28.90	"	"
Anderson, Ronald A (estate of), c/o Read & Read, Level 9 Aetna Tower, 221 Elizabeth St, Sydney, NSW	27.60	"	"
Andrews, Charles T, 33 Virginia St, Newtown	16.80	"	"
Anerdi, Linda L, 11/429 Old South Head Rd, North Bondi, NSW	13.60	"	"
Atkin, Edith M, 730 Pacific Hwy, Gordon, NSW	54.00	"	"
Atkinson, Robert D, GPO Box 1101L, Hobart, Tas	229.20	"	"
Atkinson, Ronald I, c/o Pioneer Stud, Ayr, Qld	28.00	"	"
Atyeo, Elizabeth M, c/o E M McLennan, 119 Canterbury Rd, Canterbury	64.00	"	"
Austin, John W Jnr, GPO Box 3996, Sydney, NSW	28.00	"	"
Ayers, Adonia E, 82 Denison St, Maroubra Bay, NSW	28.80	"	"
Backwell, Ian E, 253 Latrobe Tce, Geelong	304.00	"	"
Badenoch, Diana B, 3 Redmond St, Collinswood, SA	35.20	"	"
Baglin, William G, 12 Cheeseman Ave, East Brighton	76.80	"	"
Bainton, Helen, 1 Lansdowne, 20 Wiliam St, Double Bay, NSW	103.20	"	"
Bainton, John V, Flat 68, 26 Etham Ave, Darling Point, NSW	64.00	"	"
Baird, Dr John H, 28 Woolwich Rd, Hunters Hill, NSW	216.00	"	"
Baker Investments Limited, 222 Victoria Arcade, Shortland St, Auckland, NZ	149.60	"	"
Bond-Barker, Joanna, 19 Wellington St, Mosman Park, WA	24.00	"	"
Barker, Ruth N, "Garary", Curlewis, NSW	16.80	"	"
Barthold, Anne D, "Kimberley", Railway Rd, Koo-wee-rup	52.00	"	"
Batho, Patrick J, PO Box 317, Woden, ACT	64.00	"	"
Batten, Janet J, PO Box 36052, Lower Hutt, NZ	10.20	"	"
Baxter, Brian J, PO Box 590, Ayr, Qld	44.00	"	"
Bean, Claire L, 5 Jenkins St, Chatswood, NSW	13.20	"	"
Bell, Charles H E, McIvor Rd, Bendigo	21.60	"	"
Bell, Sarah A, c/o Stevenson & Barrs, PO Box 63, Derby, UK	221.00	"	"
Beniac, Judith, 13 Kywong Ave, Pymble, NSW	62.00	"	"
Benjamin, Hugh E, 67 Sutherland St, Paddington, NSW	139.20	"	"
Bertram, Heather A, 17 Oates Ave, Wagga, NSW	24.00	"	"

## Unclaimed Moneys Act 1962

## Register of Unclaimed Moneys held by the—

<i>Name of Owner on Books and Last Known Address</i>	<i>Total Amount Due to Owner</i>	<i>Description of Unclaimed Money</i>	<i>Date when Amount first became Payable</i>
\$			
COLES-MYER LTD			
Bettington, Dabce M, "Morwena", King Creek Rd, Wauchope, NSW	44.40	Dividend	13.10.84
Bettington, Rebecca M, "Morwena", King Creek Rd, Wauchope, NSW	20.40	"	"
Betty, Julie Q, 27 Worcester Cl, Southcote, Reading, Berks, UK	44.88	"	"
Bishop, Elizabeth M L, Mount Erin Rd, Hastings RD2, NZ	14.96	"	"
Black, Gina H, PO Box 25, Camperdown	96.00	"	"
Blackburn, Harvey, 154 Corella St, Howrah, Tas	10.80	"	"
Blake, Alice M, 1 Selwyn St, Canterbury	54.00	"	"
Blinkhorn, Thomas, 51 Wolli St, Kingsgrove, NSW	44.00	"	"
Blyth, James F, c/o Commonwealth Savings Bank, PO Box 34, Margate, Qld	88.00	"	"
Blyth, James W, "Haraklehe", No. 2 RD, Wanganui, NZ	89.76	"	"
Bowker, Thomas (estate of), c/o Wright Atkinson & Pearson, Cavendish House, 13 Henry St, Keighley, West Yorks, UK	157.08	"	"
Bracker, Morgan E, 52/36A Macleay St, Potts Point, NSW	94.00	"	"
Braddy, Ronald J, 8/47 Rockley Rd, South Yarra	140.00	"	"
Bradfield, Frances H, 4 Lot La, Hunters Hill, NSW	26.40	"	"
Brennan, Christopher D, 273 Blackburn Rd, East Doncaster	48.00	"	"
Brewer, Robert K, 5 Pacific Blvd, Beaumaris	36.80	"	"
Briggs, Paulin A L, 1 Furneaux Gve, Ripponlea	57.60	"	"
Brock, Doris C, Box 1009, Tintinara, SA	55.20	"	"
Brookes, Frank J W, and Chabot, Simon C, 4 Alsdworth Pde, Goring-by-Sea, Worthing, West Sussex, UK	67.32	"	"
Brooks, Roger S and Judith H, 33 Clifton St, Malvern, SA	66.00	"	"
Brown, Bessie N (estate of), c/o Box 107, Katoomba, NSW	24.80	"	"
Brown, Ivy J, 39 Gretana, Cres, Frankston	43.20	"	"
Brown, Shelley J, 4010 East Palomas Circle, La Belle, Florida, USA	14.28	"	"
Buchanan, Hilda, 98 Cambridge Tce, Malvern, SA	34.00	"	"
Bueti, John, 99 Jenkins Ave, Whyalla, SA	24.00	"	"
Burnett, Peter M, 27 Callantina Rd, Hawthorn	19.20	"	"
Burns, Carolyn A, "Canawindra", Booroobanilly La, Coree South, Finley, NSW	32.00	"	"
Burrows, Dorothy J, 32 Bettington Rd, Dundas, NSW	43.20	"	"
Bushby, Neil H, 3 Power St, Hawthorn	80.00	"	"
Butterfield, Gladys E (estate of), c/o Lloyds Bank, 100 Pall Mall, London, UK	107.52	"	"
Butts, Eve V, Park Rd, Titirangi, NZ	10.20	"	"
Byrnes, Peter B, 69 Hammel St, Beenleigh, Qld	60.00	"	"
Calder, Frank S, 70 Gawler St, Salisbury, SA	34.00	"	"
Calman, Catherine T (estate of), 13 Looke St, Essendon	24.80	"	"
Calvert, James L, "Myanbah", Uralla, NSW	176.00	"	"
Cameron, Brett C, 196 Wonga Rd, Warranwood	60.00	"	"
Cameron, Julie F, 6 Marriage Rd, Brighton	66.00	"	"
Campbell, Ray, PO Box 5295, Forth Worth, Texas, USA	115.60	"	"
Camphin, Michael D, 74/22 Peel St, Kirribilli, NSW	48.00	"	"
Camporese, Ivan C, 1/27 East St, Glenroy	19.20	"	"
Cann, Elissa M, 20 Hawthorn Ave, North Caulfield	16.00	"	"
Cann, John F, 51 Whyte St, Brighton	16.00	"	"
Carr, Richard I, c/o Glen Carr & Partners Pty Ltd, Quirk Rd, Manly Vale, NSW	36.00	"	"
Cashion, Joan, 100 Leeds St, Mt Waverley	26.40	"	"
Cavey, Clive M, 16 Boythorn Ave, Ambarvale, NSW	16.00	"	"

## Unclaimed Moneys Act 1962

## Register of Unclaimed Moneys held by the—

<i>Name of Owner on Books and Last Known Address</i>	<i>Total Amount Due to Owner</i>	<i>Description of Unclaimed Money</i>	<i>Date when Amount first became Payable</i>
\$			
COLES-MYER LTD—continued			
Cerminara, Valentino, 21 Outlook Dve, Doncaster	86.40	Dividend	13.10.84
Chalkias, Spiro D, 102 Walter Rd, Kingaroy, Qld	24.00	"	"
Chandler, Ian McK, 118 Udys Rd, Pakuranga, Auckland, NZ	149.60	"	"
Chasmay Pty Ltd, c/o M McCarthy, Miami Retirement Village, PO Box 61, Miami, Qld	149.60	"	"
Cheesman, Gertrude D (estate of), c/o G D Cann & Hallett, 40 Southernhay East, Exeter, UK	54.40	"	"
Cherry, Lucy I B, Unit 4, 11 Princes St, Burnie, Tas	36.00	"	"
Chidlow, Leonard L, 17 Tuerong St, Rye	12.00	"	"
Churcher, Geoffrey E, 6 Glen St, Mosman, NSW	13.20	"	"
Clark, Patrick J D, 1 Camelia Crt, Ferndale, WA	108.00	"	"
Clark, William J and Kathleen P, Korolevu Beach Hotel, Korolevu, Fiji	64.96	"	"
Clarke, James W, Bond A and Rowlands Harold G, PO Box 1200, Christchurch, NZ	11.22	"	"
Cleeland, Dorothy J, 2/9 Victoria St, Preston	38.00	"	"
Clemens, Pauline L, 102 Carlton St, Carlton	17.60	"	"
Coghill, Wendy V, PO Box 94, Malvern	40.00	"	"
Colchester, Geoffrey V, Puketirau Rd, Tirau RD1, NZ	29.58	"	"
Coleman, Zita F, 3 Elfreda St, Mosman, NSW	15.20	"	"
Collings, Clare E, 99 Hilton St, Glenroy	38.00	Cheque	"
Collins, David G, 56 Nicholson St, Warnambool	28.80	"	"
Collins, Florence J, 56 Nicholson St, Warnambool	25.60	"	"
Cooke, John, c/o Cooke and Cussen, 8th Floor, 128 Exhibition St, Melbourne	38.40	"	"
Coon, Neville A, 26 Clare St, Mordialloc	128.00	"	"
Cooper, Barbara J, 5 Selwyn Crt, Toorak	16.80	"	"
Cooper, Cyril J, 44 Belinda Cres, Springwood, Qld	24.00	"	"
Cooper, Mervyn N, PO Box 8145, Riccarton, Christchurch, NZ	45.90	"	"
Corcoran, Alice E J, c/o E J Corcoran and Son, 82 Cookson St, Kaiapoi, NZ	13.60	"	"
Cotter, Elizabeth A and Collins, John P, 87 Peel St, Windsor	58.00	"	"
Coulson, Lisa J, 18 Craig Rd, Donvale	32.00	"	"
Cowan, Bruce R, 17/20 Gerard St, Cremorne, NSW	105.60	"	"
Cowden, Patricia E, 44 Poinciana Blvd, Rio Vista, Qld	19.20	"	"
Cox, Charles H, 89 Birriga Rd, Bellevue Hill, NSW	60.00	"	"
Cran, Colleen W and Howard, John E, c/o Ernst and Whinney, Box 45, Collins St, Melbourne	316.80	"	"
Crocker, John, 31000 Lahser, Suite 8, Birmingham, Michigan, USA	52.36	"	"
Crombie, Mary P, 17/47 Alexandria Pde, Waitara, NSW	28.80	"	"
Crone, Nina A, Flat 18, 90 Hotham St, East Melbourne	48.00	"	"
Crosstrees Pty Limited, Unit 2, 7 Binnie St, Brighton East	475.20	"	"
Crowley, Jennifer L, 4 Barns St, South Blackburn	13.20	"	"
Cunningham, Trevor W J, 16 Hewlett Ave, North Nowra, NSW	43.20	"	"
Davidson & Co. Ltd, PO Box 122, Suite 3700, First Canadian Place, Toronto, Ontario, Canada	11.22	"	"
Davies, Brett, 29 Brallos Ave, Holsworthy, NSW	12.00	"	"
Davies, Syd, 51 Mitchell St, Bairnsdale	38.00	"	"
Davis, Andrew, 6 Grant Ave, Toorak	21.60	"	"
Davis, Howard (estate of), c/o N F Davis, 14725 Ellen Dve, Livonia, Michigan, USA	93.50	"	"

## Unclaimed Moneys Act 1962

## Register of Unclaimed Moneys held by the—

<i>Name of Owner on Books and Last Known Address</i>	<i>Total Amount Due to Owner</i>	<i>Description of Unclaimed Money</i>	<i>Date when Amount first became Payable</i>
\$			
COLES-MYER LTD—continued			
Davis, June L, 145 Russell St, Melbourne	10.80	Cheque	13.10.84
Day, Jill D, 3 Downes Ave, Brighton	96.00	"	"
Day, Lyn P, 24 Louisa Rd, Birchgrove, NSW	28.80	"	"
Dean, David C, 219 Carpenter St South, Bendigo	74.40	"	"
Delany, Catherine A, 6/23 Shirley Rd, Wollstonecraft, NSW	48.00	"	"
Dell, Kyra M, Deacon Rd, Kumeu, Auckland, NZ	13.60	"	"
Demari, Albertus P, 16 Hewlett Ave, North Nowra, NSW	104.00	"	"
Passe de Silva, Godwin C F, 23 Hampden Rd, Pennant Hills, NSW	140.00	"	"
Devlin, Christopher M, 16a Lewis St, Kalgoorlie, WA	24.00	"	"
Dillon, Margaret D, PO Box 2348, Wellington, NZ	95.20	"	"
Dionysius, Ronald M, 33 Pimpala St, Wurtulla Village, Qld	48.00	"	"
Dive, Hilda F, McLean Retiring Village, PO Box 360, Inverell, NSW	10.80	"	"
Doherty, Neil F and Eileen M, 15 Aldridge St, Auchenflower, Qld	11.20	"	"
Douglas, James A T, Unit 8 Lincoln, 84 Upper Pitt St, Kirribilli, NSW	137.60	"	"
Drysdale, Harvey N, 15 Adelaide St, Belmore, NSW	36.00	"	"
Ducker, Margaret C, "Wingala", PO Box 5, Kingstown, NSW	32.40	"	"
Duckham, Bruce W, Lot 3, Iron Rd, Parkerville, WA	56.00	"	"
Duggan, Cornelius, 20 Virginia St, Kensington, NSW	324.00	"	"
Duncan, Kathleen and Malley, Edmund M, PO Box 25054, Christchurch, NZ	85.68	"	"
Dunlop, Jane I, c/o J I Walker, Brigalow Park, North Star, NSW	74.00	"	"
Dunlop, John S, c/o PO, Koolan Island, WA	38.40	"	"
Dwyer, Robert S F, 40 Wolsley Rd, Coogee, NSW	32.00	"	"
Eagles, Richard G, 22 Galvin Rd, Llandilo, NSW	28.00	"	"
Earls, James S, 310 Blaxland Rd, Ryde, NSW	54.00	"	"
Edwick, Hilary E, 18 Tasman Ave, Belmont	13.20	"	"
Elder, John, 15 Brabyn St, Eastwood, NSW	116.00	"	"
Elgee, Evelyn E S (estate of), 4 Darley Heights, Darley St, South Perth, WA	434.40	"	"
Ellingham, Michael C, 48 Grand View Rd, Hamilton, NZ	25.84	"	"
Everett, Samuel C (estate of), c/o J H Everett, 52 Hayle St, St Ives, NSW	44.00	"	"
Fairlamb, Ronald W, The Willows, Ireton Ave, Walton-on-Thames, Surrey, UK	129.88	"	"
Fenton, Donald, 65 Woolgoolga St, North Balgowlah, NSW	30.00	"	"
Finlay, Cecil I, 150 Homebush Rd, Strathfield, NSW	102.40	"	"
First of Michigan Corporation, 1200 Buhl Building, Detroit, Michigan, USA	187.00	"	"
Fisher, David H, c/o 39 Wairarapa Tce, Christchurch, NZ	18.36	"	"
Fitzsimmons, Olga M, 41 McNaughton Ave, Maryland, Newcastle, NSW	28.80	"	"
Fitzsimons, Norma A, Unit 10, "Aroona Court", 110 Spit Rd, Mosman, NSW	172.00	"	"
Flavell, Charles R, RD 4, Wellsford, NZ	20.40	"	"
Flavell, Marie V, RD 4, Wellsford, NZ	20.40	"	"
Foot, Stewart C and Haggarty, H, 288 Queen St, Brisbane, Qld	84.80	"	"
Forsyth, Alan G, c/o Church of St Barbara, PO Box 200, Woomera, SA	13.20	"	"
Fox, Peter, 48 Irving Rd, Toorak	20.40	"	"
Francois, Jean M, 26 Jamison St, Laverton	24.00	"	"
Freeman, Henry, Montefiore Homes, 619 St Kilda Rd, Melbourne	80.00	"	"



## Unclaimed Moneys Act 1962

## Register of Unclaimed Moneys held by the—

<i>Name of Owner on Books and Last Known Address</i>	<i>Total Amount Due to Owner</i>	<i>Description of Unclaimed Money</i>	<i>Date when Amount first became Payable</i>
\$			
COLES-MYER—continued			
Fyffe, Marion L, 14 DRD, Oamaru, North Otago, Dunedin, NZ	18.36	Cheque	13.10.84
Gabb, Andrew C, "Black Creek" Beaufort	11.20	"	"
Gallagher, Edward A, 23 Taro St, Blakehurst, NSW	13.60	"	"
Galvin, Barbara J, 103 Clow St, Dandenong	54.00	"	"
Gascoigne, Joan C (estate of), c/o Meares Williams, PO Box 660, Christchurch, NZ	42.00	"	"
Gatward, Mark A T, Flat 4, 75 Hapua St, Auckland, NZ	14.28	"	"
Gazey, Marie L, 11 Boya Cres, Boya, WA	31.20	"	"
Geffen, Maud E (estate of), c/o Overseas Probate Service Ltd, Park House, Bexley, Kent, UK	224.40	"	"
Gifford, George A, Thickwood House, Thickwood, Coleme, Wiltshire, UK	56.10	Dividend	"
Gillespie, Helen J, 2 Carson Ave, Mont Albert	24.00	"	"
Gisz, Lillian J, RMB 738A, Mummel Rd, Goulburn, NSW	105.60	"	"
Goldstein, Colman B and Harold G, Grantham Lodge, Grantham St, Potts Point, NSW	127.20	"	"
Goodman, Christopher R, 32 Gumeracha Rd, O'Sullivan Beach, SA	28.80	"	"
Goodman, Phyllis R, 21871 Ridgedale St, Oak Park, Michigan, USA	11.22	"	"
Gordon, Mabel P, c/o Webley & Ruby, Ward St, Dannevirke, NZ	42.50	"	"
Goswell, Mignon, 113 Court St, Manilla, NSW	11.20	"	"
Graham, Philippa M, "Mahoe", Cannington, Cave, South Canterbury, NZ	40.80	"	"
Gramahlo Proprietary Limited, c/o R H Morrison, 37 Swanston St, Melbourne	222.00	"	"
Grass, Jack (estate of), c/o Rogers & Gaylard, 31 Queen St, Melbourne	127.20	"	"
Gray, Gertrude M, 2/1 Sylvan Crt, Newtown	96.00	"	"
Gray, Shirley M, 5 Wonga Wonga St, Turramurra, NSW	490.00	"	"
Greathead, Sydney, 2 Stonehaven Rd, Mt Colah, NSW	13.20	"	"
Green, Maxwell J, c/o Oxenford PO, Qld	60.00	"	"
Green, Vera M, GPO Box 1287, Brisbane, Qld	146.00	"	"
Grieve, Elizabeth J, 50 Brandreth St, Tusmore, SA	164.40	"	"
Griffiths, David J and Norman, 317A Nepean Hwy, Edithvale	23.20	"	"
Grocott, Muriel L, c/o H. Ravenscroft, 117 Homer St, Earlwood, NSW	10.80	"	"
Guest, Mark G, 34 Manchester St, Eight Mile Plains, Qld	54.00	"	"
Guihard, Didier B, 10 Edlington St, Hawthorn	24.00	"	"
Guse, Robert F, 81 Reynolds Pde, Pascoe Vale	60.00	"	"
Smith-Haggie, Kathryn, Low Barton Farm, Whittingham, Alnwick, Northumberland, UK	71.40	"	"
Hallgreen, Victoria C, 6 Chandos St, Coburg	79.20	"	"
Hamilton, Margaret J, PO Box 433, Devonport, Tas	32.00	"	"
Hannan, Pamela, 8 Birch St, Mount Waverley	44.00	"	"
Harmer, Benjamin F, 27 Garnsworthy St, Springvale	16.80	"	"
Harold, Bessie G, 75 Tanundal St, Howra, Tas	54.00	"	"
Hart, Susan M, 27 Ormonde Ave, Warradale, SA	234.00	"	"
Hatteridge Development Corporation Pty Limited, 196 Rowe St, Eastwood, NSW	44.00	"	"
Hawkes, Francis G, 124 Bessener Rd East, Swindon, Wiltshire, UK	11.22	"	"
Head, Arthur G (estate of), c/o John A Carrad, 2nd Floor, Harcourt Chambers, 43 Panama St, Wellington, NZ	68.00	"	"
Healey, Leslie W G, 7 Emerson St, Toowong, Qld	16.80	"	"

## Unclaimed Moneys Act 1962

## Register of Unclaimed Moneys held by the—

Name of Owner on Books and Last Known Address	Total Amount Due to Owner	Description of Unclaimed Money	Date when Amount first became Payable
\$			
COLES-MYER LTD—continued			
Healy, Mary B, 2/576 Coronation Dve, Toowong, Qld	64.00	Dividend	13.10.84
Hearne, Christine M (estate of), c/o Mills Curry & Gaskill, 132 Kenton Rd, Kenton, Harrow, Mdx, UK	18.36	"	"
Heinz, Joanne P, c/o J. P. Watson, 249 King St, Hamilton	20.40	"	"
Henry, Andrew G, Streams Farm, Anstye, Cuckfield, Sussex, UK	72.08	"	"
Herrera, Alfred C, 40 Threlfall St, Chifley, ACT	142.00	"	"
Hicks, Jennifer H, 18 Miller St, Gilgandra, NSW	20.40	"	"
Hire Transport Ltd, 2 Rata Rd, Cheltenham, Devonport 9, NZ	86.70	"	"
Hiscock, Pamela A, "Newhaven", Moorooduc Rd, Baxter	18.40	"	"
Hobson, Virginia, 191 Dorset Rd, Croydon	28.00	"	"
Hofbauer, Samuel H, 22 Daley St, Bentleigh	212.00	"	"
Hoggart, Joan M, 94 Hilton St, Mt Waverley	38.40	"	"
Hollote, Bernard K, RMB 2030, Queanbeyan, NSW	13.20	"	"
Hollote, Helen G, RMB 2030, Queanbeyan, NSW	44.00	"	13.1.86
Holman, Edna M, 76 Terry St, St Peters, NSW	50.40	"	"
Holmes, Peter H, 38 Redesdale Rd, Ivanhoe	996.00	"	"
Hooke, Alison M, 2/6 Mountain Gve, Kew	110.00	"	"
Hoppe, Joan P, 2/4 Miami St, East Hawthorn	35.20	"	"
Hoy, Corinella, 1091 North Rd, South Oakleigh	10.80	"	"
Hudson, Elizabeth D'E, 19/105A Darling Point Rd, Darling Point, NSW	13.60	"	"
Hunt, Janice A, 523 Willarong Rd South, Caringbah, NSW	40.00	"	"
Hurst, Kim B, Boyanup, WA	13.60	"	"
Hutcherson, Margaret, 56b Telegraph Rd, Pymble, NSW	44.40	"	"
Hutchison, Ellen C (estate of), c/o Parry Ware & Carroll, 15th Floor, St James Centre, 111 Elizabeth St, Sydney, NSW	152.80	"	"
Hutton, Ivan G, 13 Davidson Tce, Teneriffe, Qld	60.00	"	"
Hwang, Edward E, 11 Woodman St, Cook Point, Port Hedland, WA	22.80	"	"
Imrich, Allison M, 251 N Ogilvie St, Prince George, BC, Canada	32.30	"	"
Inglis, Norman S, Flat C, Daniel St, Newtown, Wellington, NZ	12.92	"	"
Ingrouille, Bromwyn K, 7/6 Grafton Cres, Dee Why, NSW	28.80	"	"
Inkson, Bernard J, "Omihiri", No 3 RD, Amberley, Canterbury, NZ	137.36	"	"
Ivin, Betty M, 48 Maffey's Rd, McCormacks Bay, Christchurch NZ	136.00	"	"
Jackson, James P, PO Box 680, Port Pirie, SA	40.00	"	"
Jackson, Susan M, Hacketts Rd, No 10 RD, Palmerson North, NZ	10.20	"	"
Jacobsen, Ivy I, 61 Orange Ave, Mildura	48.00	"	"
James, David B, 332 Station St, North Carlton	10.80	"	"
James, Grace I (estate of), c/o P R Rule, 351 Bell St, Preston	29.60	"	"
James, Ralph, 68 Condomine St, Turner, ACT	66.00	"	"
James, Warwick S, 332 Station St, North Carlton	10.80	"	"
Jaques, Maryan E, 9 High St, Beaumaris	10.80	"	"
Jasper, Victor F, c/o PO Box 39, Cunderdin WA	16.80	"	"
Jenkins, Nancy, Lot 7, Mackelroy Rd, Plenty	28.80	"	"
Jenkins, Thelma H, Camden Ridge, Southhill Road, Chislehurst, Kent, UK	59.84	"	"
Jermyn, Garry R, 2/49 McKern St, Campsie, NSW	13.20	"	"
Johnson Cheryl M, 60 Butler St, North Richmond	54.00	"	"
Johnson, Peter F (estate of), c/o Adamson & Kyle, PO Box 742, Southport, Qld	13.20	"	"
Johnson, Ronald E, 9 Devon St, South Brighton, SA	80.00	"	"
Jolly, Alexander H and Hearle, Peter J, c/o T W Biggs & Biggs, 33-35 Herschel St, Brisbane, Qld	1040.80	"	"

## Unclaimed Moneys Act 1962

## Register of Unclaimed Moneys held by the—

<i>Name of Owner on Books and Last Known Address</i>	<i>Total Amount Due to Owner</i>	<i>Description of Unclaimed Money</i>	<i>Date when Amount first became Payable</i>
\$			
COLES-MYER LTD—continued			
Jones, Stephen M, 31 Wootton Cres, Springwood, Qld	36.00	Dividend	13.1.86
Jordan, Leonard F (estate of), c/o J W Walker and D K L Raphael, PO Box 255, Parramatta, NSW	175.20	..	..
Jorgensen, Janice, c/o N Jorgensen, 142 Edenburgh Rd, Castlecrag, NSW	18.40	..	..
Joseph, Margaret E (estate of), c/o Septimus Jones & Lee, 7th Floor, 257 Collins St, Melbourne	316.00	..	..
Joyce, Peter S, 24 The Rope Walk, Nottingham, UK	38.76	..	..
Kanji, Shamsher H M, c/o Midland Bank Ltd, Poultry and Princes Sts, London, UK	40.80	..	..
Kennaugh, Frederick R, 20 Bonita Crt, Dandenong	507.20	..	..
Keys, Evelyn M, "Degilbo Station", Mail Service 650, Biggenden, Qld	118.00	..	..
Kimpton, Sheila F, 2 Brookville Rd, Toorak	382.00	..	..
King, Annette (estate of), c/o Walker Gibbs & King, PO Box 8, Cooma, NSW	370.00	..	..
King, Penelope H, c/o P H Ure, 2/32 Judge St, Randwick, NSW	104.00	..	..
Kinsella, Raymond J, 15 Barholme Crt, South Oakleigh	26.40	..	..
Knowles, Beth C, No 1 RD, Geraldine, NZ	25.16	..	..
Koochew, Evelyn J, 22 Brunton Cres, Tullamarine	32.40	..	..
Kwok, Frank W, 4 Rawson Pl, Seatoun, Wellington, NZ	81.60	..	..
Kylander Pty Ltd, GPO Box 3871, Sydney, NSW	380.80	..	..
Lamb, Russell, 4 Kinsello St, Queanbeyan	24.00	..	..
Landahl, Paul, 5/58 Bradshaw Dve, Alice Springs, NT	36.00	..	..
Larner, Francis M, c/o PO Box 105, Hastings, NZ	26.52	..	..
Latham, Ashton W, PO Box 150, Frankston	32.00	..	..
Lawrence, Maxwell, 87 Koetong Pde, Mt Eliza	61.20	..	..
Lawrence, Ruby A, PO, Healesville Rd, Woori Yallock	10.80	..	..
Lea, Haidee A, "Twin Hills", RMB Tumbi Rd, Tumbi Umbi, NSW	151.20	..	..
Leddy, Edward Jnr, 50 Warragal Rd, Turramurra, NSW	38.40	..	..
Lederman, Elie, 7 Vadlure Ave, East St Kilda	11.20	..	..
Leeming, Janet R, 21 Newport Tce, Seatoun Heights, Wellington, NZ	108.80	..	..
Leggo, Dr Peter J, 37 Almoners' Ave, Cambridge, UK	11.22	..	..
Le Grew, Henry L, 1 Wentworth Ave, Canterbury	34.00	..	..
Levay, John A and William C L, 13 Clifford Rd, New Barnet, Herts, UK	115.60	..	..
Lewis, Gay L, 62 Highett St, Richmond	202.00	..	..
Lewis, Phillipa, "Burrandowan", Tingoorra, Qld	127.20	..	..
Lindsay, Barbara L, 147 Hamilton Ave, Christchurch, NZ	45.90	..	..
Lloyd, Dean S, 17 Birdwood St, East Kew	38.00	..	..
Lo, Kwong W, 801 Franklin St, No. 1239, Oakland, California, USA	71.40	..	..
Lukas, John S, 16 Daly Ave, Concord, NSW	32.40	..	..
Lukins, Murrie J, 25 Darling St, Moonsee Ponds	26.40	..	..
MacDonald, Donald J, 94 Powlett St, East Melbourne	146.00	..	13.10.84
Machado, Elaine L A, 5 Bowater Cl, Wahroonga, NSW	16.00	..	..
MacMillan, Janet M, Flat 9, 18 York St, Mont Albert	34.40	..	..
MacQueen, Lilian F, 19 Eastview Ave, Church Point, NSW	32.00	..	..
MacRae, Jessie D, 75 High St, Great Doddington, Wellingborough, Northants, UK	57.12	..	..
Maddever, Neil L C, 50 Hawke St, West Melbourne	26.00	..	..
Maitland, Peter E, 9 Spencer Pl, Hughes, ACT	28.80	..	..
Malligan, Margaret P, 10/16 Normanby St, Windsor	34.00	..	..

## Unclaimed Moneys Act 1962

## Register of Unclaimed Moneys held by the—

<i>Name of Owner on Books and Last Known Address</i>	<i>Total Amount Due to Owner</i>	<i>Description of Unclaimed Money</i>	<i>Date when Amount first became Payable</i>
\$			
COLES-MYER LTD—continued			
Marinovich, Vinka M, 5 Salisbury St, Herne Bay, Auckland, NZ	62.90	Dividend	13.10.84
Marshall, Ivy J, 47 Field St, Shepparton	61.20	"	"
Martin, John H, 64 Northbourne Ave, Canberra, ACT	21.60	"	"
Mary Wright Investments P/L, 39/8 Darley St, South Perth, WA	919.20	"	"
Mason, Lorna E, 8 Middle Rd, Camberwell	832.00	"	"
Masterman, Lindis, PO Box 408, Canberra City, ACT	253.60	"	"
Mather, George C L M, c/o PO Box 1354, Christchurch, NZ	38.76	"	"
Mattiske, Vera F, c/o Farmers Co-operative Executors & Trustees Ltd, 33 Bentham St, Adelaide, SA	192.00	"	"
Wedderburn-Maxwell, Anne M, The Granary East Rd, St George's Hill, Weybridge, Surrey, UK	136.00	"	"
McCarten, Gordon G (estate of), c/o 34 Meaklim St, Shepparton	15.20	"	"
McClelland, Tony A, 9 Ashford Pde, Merewether Heights, NSW	120.00	"	"
McCormack, Denis M, c/o Christopher J Holland, 33 Bell St, Fitzroy	72.00	"	"
McCormack, Walter, Traralgon South	39.60	"	"
McCraith, Gerald, 107 Roberts St, Essendon	380.80	"	"
McGavin, Mary H, 19 Richmond Ave, Northcote, Auckland, NZ	102.00	"	"
McGettigan, Brian O P, c/o Henson Park Hotel, 91 Illawarra Rd, Marrickville, NSW	32.00	"	"
McGibbony, Patricia M, c/o L McGibbony, 2/12 Laburnum St, Brighton	48.00	"	"
McIver, Kenneth J, PO Box 3, Eureka St, Ballarat	132.00	"	"
McKay, Neil G, 4/105 Hearn St, Colac	60.00	"	"
McKellar John S, and Maureen T, 7 Sampson St, Orange, NSW	12.00	"	"
McKenna, Neil W, 58 Essex St, Oxford Park, Qld	72.00	"	"
McLean, Gordon A (estate of), c/o Mrs McLean, 126 Hawken Dve, St Lucia, Qld	256.80	"	"
McLeod, Thelma M, 7 Thomson Rd, Claremont, WA	13.60	"	"
McNaught, Una E, c/o Peat Marwick Mitchell & Co, PO Box 996, Wellington, NZ	44.88	"	"
MDS Pty Ltd, and Peat Marwick Mitchell & Co, GPO Box 2499, Adelaide, SA	96.00	"	"
Mead, Barry W, 15 Miami St, Mangere East, Auckland, NZ	51.00	"	"
Meiklejohn, Myra F, 89 Brynley St, Hornby, Christchurch, NZ	13.26	"	"
Merlan Investments Pty Ltd, c/o J Allen, 7 Kirk Ave, Ascot Vale	102.00	"	"
Mertz, Joseph L, 14761 Rosemary, Detroit, Michigan, USA	72.08	"	"
Middleton, John C A, Widcombe Hill House, Bath, UK	12.24	"	"
Middleton, Karolyn, PO Box 378, Lavington, NSW	13.20	"	"
Miller, Annege, 2 Caroline St, East Gosford, NSW	28.80	"	"
Mills, Owen C, 20 Hinemoa St, Birkenhead, Auckland, NZ	39.10	"	"
Mills, Patricia I, 41 Chaleyer St, Reservoir East	27.60	"	"
Mitchell, Allen W, 48 Gardner St, Richmond	16.80	"	"
Mitchell, Beryl J, 29/28 Fulton St, East St Kilda	13.20	"	"
Mitchell, Dr William S, 147 Westbourne Gve, Northcote	58.80	"	"
Mojtahedi, Mohammad, 122 North Kakh Ave, PO Box 14-1225, Tehran, Iran	17.36	"	"
Molyneux, Thelma M, PO Box 45, Berwick	36.00	"	"
Montgomerie, Elizabeth I G, Bainbridge, Lynette E, Patterson, Ross H, 6 Horotutu Rd, One Tree Hill, Auckland, NZ	213.52	"	"
Montgomery, David R, 40 Raff Ave, Holland Park, Qld	36.00	"	"
Morey, Kerry J, 63 Fowler St, Camperdown, NSW	54.00	"	"

## Unclaimed Moneys Act 1962

## Register of Unclaimed Moneys held by the—

<i>Name of Owner on Books and Last Known Address</i>	<i>Total Amount Due to Owner</i>	<i>Description of Unclaimed Money</i>	<i>Date when Amount first became Payable</i>
\$			
COLES-MYER LTD— <i>continued</i>			
Morris, Elaine, c/o Daniel J Lee, Public Accountant, PO Box 208, Doveton	1056.00	Cheque	13.10.84
Morrison, Zelda, c/o Morrison Morrison Tyree & Co, 716 Market St, Knoxville, Tennessee, USA	28.56	"	"
Morton, John B, c/o Department of Surgery, Christchurch Clinical School, Christchurch Hospital, Christchurch, NZ	11.22	"	"
Murphy, Freda A, Springston, RD 4, Christchurch, NZ	18.36	"	"
Musgrave, John T, 6 Doris Pl, Armidale, NSW	96.00	"	"
Nelson, James H, PO Box 1492, Wellington, NZ	32.30	"	"
Newman, Hylde G, Unit 5, 68A West St, Balgowlah, NSW	160.00	"	"
Nicholls, Noeline A, 11 Bay St, Coogee, NSW	14.40	"	"
Nicholle, Russell P, 53 Totara Rd, Miramar, Wellington, NZ	10.20	"	"
Noble, Margery, The Lodge, Rushall Park, North Fitzroy	21.60	"	"
Nolan, Barbara M, 18 Siota Cres, Kohimarama, Auckland, NZ	142.80	"	"
O'Connor, Eileen, 1 Kevin Gve, Kew	57.60	"	"
O'Driscoll, Kathleen G, 26 Daymar St, Castle Cove, NSW	32.00	"	"
Olsen, Svann O, 13 Fuller St, Heatley, Townsville, Qld	131.20	"	"
O'Neill, John N, 107 Harold St, Middle Park	10.80	"	"
Orlandi, Lina, 44 Dorothy St, East Burwood	43.20	"	"
O'Shea, Margaret J, 34 Wolfe St, Newcastle, NSW	43.20	"	"
Ovens, Charles D, 5 Matipo Rd, Mairangi Bay, Auckland, NZ	32.64	"	"
Parish, Colin J, 577 Russley Rd, Christchurch, NZ	129.20	"	"
Parker, Irene M, 22 Koala Cres, West Meadows	60.00	"	"
Parker, John F (estate of) and Daniel N Doohan (estate of), c/o St Patrick's College, Silverstream, NZ	160.00	"	"
Parker, Keith R, 30 Lorinya St, Mansfield, Qld	17.60	"	"
Pate, John W (estate of), c/o R G Pate, 26 Redman Pde, Belmore, NSW	22.80	"	"
Patterson, Harvey T, 33 Martin St, Harbord, NSW	105.60	"	"
Patterson, Isabel M (estate of), c/o Farmers Trustee, GPO Box 365, Adelaide, SA	51.20	"	"
Paul, Brian L, 50 Garden Cres, Kirwan, Townsville, Qld	13.20	"	"
Paull, Joan E, 23 McGinn Rd, Ferny Grove, Qld	40.00	"	"
Payne, Albert G, 10 Dean Tce, Liskeard, Cornwall, UK	38.08	"	"
Pegler, James B, Dormers, Deepdene Wood, Dorking, Surrey, UK	14.96	"	"
Pegler, Roy L, 9 Fourth Ave, Eastwood, NSW	240.00	"	"
Penney, James M, Weavers Rd, Maroota, NSW	13.60	"	"
Perrie, Queen L, Flat 4, Peebles Flats, Minora Dve, Rivervale, WA	26.00	"	"
Perry, Rachel M, 49 Voelas Rd, Lyttelton, NZ	15.64	"	"
Persson, Dorothy M, 12 Warrowa Ave, West Pymble, NSW	54.00	"	"
Petty, John C, La Chaumiere, Rue Des Bois St John, Jersey, Channel Islands	80.64	"	"
Phillips, Gita C, 4 Emma St, Caulfield	11.20	"	"
Phillips, John B, PO Box 392, Devonport, Tas	48.00	"	"
Phillips, Raymond W, 9 Latimer Rd, Bellevue Rd, Bellevue Hill, NSW	68.80	"	"
Philp, Gladys E, c/o R K Philp, 38 Darnley St, Gordon, NSW	68.40	"	"
Place, Edwin, 2119 Century Oak La, Orchard Lake, Michigan, USA	187.00	"	"
Plume, Charles W, 7/52 O'Dell St, Armidale, NSW	48.00	"	"
Plumley, Harold C, 6 Prangley Ave, Mangere, Auckland, NZ	194.48	"	"
Plumley, Harold C, Jnr, 6 Prangley Ave, Mangere Central, Auckland, NZ	22.44	"	"

## Unclaimed Moneys Act 1962

## Register of Unclaimed Moneys held by the—

<i>Name of Owner on Books and Last Known Address</i>	<i>Total Amount Due to Owner</i>	<i>Description of Unclaimed Money</i>	<i>Date when Amount first became Payable</i>
§			
COLES-MYER LTD—continued			
Podbury, Murray B, 5 Vanessa Crt, Frankston	241.20	Cheque	13.10.84
Pogson, Nora, 26 Brentwood Crt, Morley Rd, Southport, Lancs, UK	44.88	"	"
Pollock, Jeffrey N (estate of) and Tarrant, Phillip J, PO Box 30, Grafton, NSW	32.40	"	"
Potts, Dr John, c/o Australian Embassy, Athens, Greece	10.08	"	"
Prebble, Mervyn D, 33 Crichton Tee, Christchurch, NZ	47.60	"	"
Pryor, David K, 100 Seven St, Box Hill	13.20	"	"
Pugh, Alan H, 93 Maltravers Rd, Ivanhoe	10.80	"	"
Pullino, Giuseppe, 99 Jenkins Ave, Whyalla, Norrie, SA	24.00	"	"
Purvis, Lorna R, 19 Oliver St, Ashburton South	46.40	"	"
Quint, Graham L, 26 West St, Preston	92.00	"	"
Radford, Margaret E, 9 Iona Ave, Toorak	144.00	"	"
Rafferty, Muriel A, 18 Abbot St, Yarralumla, ACT	106.00	"	"
Ralston, Judith C, 48A Nelson St, Gordon, NSW	44.00	"	"
Raman, Anthony J, 40 Avenue Rd, Prospect, SA	54.00	"	"
Rands, Elisabeth S, A/c National Westminster Bank, 8 Station Pde, Kew Gardens, Richmond, Surrey, UK	80.92	"	"
Ranken, Laura M, "Boorara", Avenel	362.40	"	"
Raymond Terrace Real Estate Sales Pty Ltd, 46 William St, Raymond Terrace, NSW	214.00	"	"
Redpath, Onah, 41 Maungakiekie Ave, Green Lane, Auckland, NZ	394.40	"	"
Reed, Patricia, 22 William St, Port Macquarie, NSW	67.20	"	"
Reid, Mary E, 39 Sandford St, Highett	150.00	"	"
Richards, Gordon G, 55A Glandovey Rd, Christchurch, NZ	112.20	"	"
Richardson, Merv, 39 James St, Mount Morgan, Qld	44.00	"	"
Riddell, Douglas C, 253 Mount St, Burnie, Tas	72.00	"	"
Riddell, Nellie E, Unit 11, 179 High St, North Sydney, NSW	48.00	"	"
Riley, Roger M, 16 Mackaye Way, Hillary, WA	180.00	"	"
Ritchie, David A, 43 St Albans St, Christchurch, NZ	14.28	"	"
Roberts, Florence E, 83 Locksley Rd, Ivanhoe	32.00	"	"
Robinson, Chris, 381 Bruce Ave, Paraburdoo, WA	40.00	"	"
Robinson, Rodney C, North Qld Aero Club, Aeroglen, Cairns, Qld	10.80	"	"
Robson, Anne M, 35 View Rd, Campbells Bay, Auckland, NZ	54.40	"	"
Roche, Michael A, D-2116 Braddell View, Singapore	40.80	"	"
Rogers, Bettine E, 9 Temby St, Watsonia	36.00	"	"
Rogers, Trevor M, 10 Ventnor St, Chadstone	11.20	"	"
Ross, Marjorie B, 1/77 Clendon Rd, Toorak	127.20	"	"
Ross, Mary A, 110 Domain St, South Yarra	98.00	"	"
Rothery, David J and Catherine M, 30A Wattle St, Killara, NSW	39.60	"	"
Rowland, Judith A, 20 Miranda Rd, Miranda, NSW	32.00	"	"
Royal Queensland Society for the Prevention of Cruelty, The, 301 Fairfield Rd, Fairfield, Qld	416.40	"	"
Rulfs, Gregory C, Wardroom, HMAS Albatross, RANAS, Nowra, NSW	13.20	"	"
Ryan, Patricia, Flat 6, "Astor Court", cnr Wharf and Leichhardt Sts, Brisbane, Qld	148.00	"	"
Ryan, Paul A, c/o Department of Forests, Konedobu, PNG	41.36	"	"
Sandow, Christine M, 50 Anderson Rd, East Hawthorn	18.40	"	"
Sankey, Craig, 15 Aldinga St, Blackmans Bay, Tas	12.00	"	"
Schottenstein, Ben, 721 Central Ave, Cincinnati, Ohio, USA	187.00	"	"

## Unclaimed Moneys Act 1962

## Register of Unclaimed Moneys held by the—

<i>Name of Owner on Books and Last Known Address</i>	<i>Total Amount Due to Owner</i>	<i>Description of Unclaimed Money</i>	<i>Date when Amount first became Payable</i>
\$			
COLES-MYER LTD—continued			
Selig, Willy (estate of), c/o Ruth E, 3 Kings Crt, Kings Dve, Forty La, Wembley Park, Middlesex, UK	67.32	Cheque	13.10.84
Seppelt, Anthony J, 25 Davenport Tce, Hazelwood Park, SA	16.00	"	"
Seymour, James E, "Mangaone", Private Bag, Gisborne, NZ	47.94	"	"
Seymour, Dr John H, 183 Macquarie St, Sydney, NSW	14.40	"	"
Shannon, Charles H, 44 McCaul St, Taringa, Qld	80.00	"	"
Sharp, Leslie D, 1548 Heatherston Rd, Dandenong	20.00	"	"
Sharpe, Peter J, c/o Sharpes Hardware Pty Ltd, Exford St, Brisbane, Qld	44.00	"	"
Shaw, Simon J, 24 Maire St, Eastbourne, Wellington, NZ	24.48	"	"
Shea, Marie McD, 12 Waimea La, Auckland, NZ	108.12	"	"
Sherry, Brian A, 5 Moran Rd, Kalamunda, WA	20.40	"	"
Shield Life Assurance Ltd and Evan D Murray-Prior, 83 Mount St, North Sydney, NSW	82.00	"	"
Simmonds, Aileen M, 202 Barnard St, Bendigo	60.00	"	"
Simpson, Alberta, 13 Crane St, Homebush, NSW	64.00	"	"
Simpson, Allan W, 13 Acheron St, Doncaster West	66.00	"	"
Simpson, James E, 4 Narrak Rd, Balwyn	36.00	"	"
Sinfield, Keith H, 34 Birubi Cres, Bilgola Plateau, NSW	44.00	"	"
Singer, Shirley E, 68 Salisbury Rd, Rose Bay, NSW	25.20	"	"
Singleton, Owen P, 15 Cass Ave, Croydon	428.00	"	"
Sinnott, Daniel and Judith A, 8129 Buckingham St, Allen Park, Michigan, USA	93.50	"	"
Skevington, Ronald J, 184 Labouchere Rd, Como, WA	28.00	"	"
Skott Investments Limited, Renscault House, East Baldwin, Isle of Man	377.40	"	"
Slinger, Joan A, 16 Mills Rd, Gosnells, WA	30.00	"	"
Sloan, John M, Darlington Rd, Mortlake	36.00	"	"
Small, Peter A, 18 Edinburgh Cres, Woolooware, NSW	18.40	"	"
Smalpage, Mary J, Unit 3, 145A Kurraba Rd, Neutral Bay, NSW	440.00	"	"
Russell-Smith, Margaret E, c/o ANZ Executors & Trustee Co Ltd, GPO Box 389D, Melbourne	219.20	"	"
Smith, Neil M, B 1035 Logan Rd, Holland Park, Qld	28.80	"	"
Smith, Norah P, Flat 32, 143 Kurraba Rd, Neutral Bay, NSW	84.00	"	"
Snell, Michael J, Beards, Fremington, Devon, UK	10.88	"	"
Sokolski, Aaron, 43 Hardware St, Melbourne	96.00	"	"
Speirs, George B, 17 Jessamine Ave, Windsor	266.40	"	"
Speirs, Jennifer J, c/o J J Carter, 10 Keane St, Peppermint Grove, WA	20.40	"	"
Spink, Jonathan B, c/o National Australia Savings Bank, GPO Box 84A, Melbourne	16.80	"	"
Staaen, Sally L, c/o Post Office, Medina, WA	33.60	"	"
Stafford, Peter J, 12/12 Waterloo St, Bulli, NSW	24.00	"	"
Stankey, Robert J, Apt 110, 1511 First St, Detroit, Michigan, USA	130.90	"	"
Stanley, Dawn M, 1181 Burke Rd, Kew	34.00	"	"
Stavrow, Helen, 481 Homer St, Earlwood, NSW	72.00	"	"
Stevens, Peter, 2 Hamlet St, Wendouree	76.80	"	"
Stevens, Peter L, The Bungalow, Park Farm, Quatt, Bridgnorth, Salop, UK	134.64	"	"
Stewart, Dr William R, 9 Exmouth Rd, Northcote, Auckland, NZ	86.70	"	"
Stiffe, William J (estate of), c/o B W Minell, GPO Box 2403, Sydney, NSW	422.40	"	"
Stillman, William L, 30 Huntington Dve, Glenalta, SA	96.00	"	"
Stirling, William L, 18 Park St, Richmond	13.20	"	"

## Unclaimed Moneys Act 1962

## Register of Unclaimed Moneys held by the—

<i>Name of Owner on Books and Last Known Address</i>	<i>Total Amount Due to Owner</i>	<i>Description of Unclaimed Money</i>	<i>Date when Amount first became Payable</i>
\$			
COLES MYER LTD— <i>continued</i>			
Stone, John R, 79 Winyard Dve, Mooroolbark	19.20	Dividend	13.10.84
Stones, David I, 3/7 Simpson St, Northcote	28.00	"	"
Stralow, Coral M, 4/587 Anzac Pde, Kingsford, NSW	72.00	"	"
Stratton, Judith F, Flat 10, 82 Dickens St, Elwood	60.00	"	"
Strausz, George (estate of), c/o Uther Webster & Slezak, 5th Floor, 44 Bridge St, Sydney, NSW	74.00	"	"
Sunderland, Jean K, c/o The Manager, Bank of New South Wales, Lambton Quay, Wellington, NZ	64.60	"	"
Suter, Ian M, 82 Sandford St, St Lucia, Qld	264.00	"	"
Sutherland, June C, 144 Barkers Rd, Hawthorn	20.40	"	"
Suttle, Leith, 76 Schoefield Pde, Keppel Sands, Qld	11.20	"	"
Symington, Peter C, 41 Carolyn St, Adamstown Heights, NSW	24.00	"	"
Szabo, Alex, 200 Parry St, Charleville, Qld	28.80	"	"
Taafe, Aileen F, PO Box 67, Elwood	13.60	"	"
Tasik, Michael S, 3 Thornleigh St, Thornleigh, NSW	24.00	"	"
Tate, Alan F, 9 Beresford Cres, Rose Bay, NSW	11.20	"	"
Taylor, Kevin A, 8 Howell St, East Brighton	15.20	"	"
Taylor, Vaida R, 33 Brentwood Ave, Pascoe Vale South	36.00	"	"
Teague, Michael J L, "Mining Vale", Rockvale Rd, Armidale, NSW	28.00	"	"
Tebecis, Maija, 19 Investigation St, Red Hill, ACT	40.00	"	"
Thomas, Fred W, Thomas Rd, East Tamaki, NZ	64.60	"	"
Thompson, Mary M, 17 Campbell St, South Perth, WA	26.40	"	"
Thonard, Joan U, c/o J U Paton, RSD, Lancaster Rd, Kyabram	24.00	"	"
Todd, Lorraine E (estate of), c/o A G Todd, 37 Lombard St, Glebe, NSW	54.00	"	"
Tonkin, Helena V M (estate of), c/o Apted & Williamson, 63 Yarra St, Geelong	21.60	"	"
Townsend, Phillip, 170 Calam Rd, Sunnybank Hills, Qld	108.00	"	"
Tralian Pty Ltd, c/o The Secretary, PO Box 121, Broken Hill, NSW	524.00	"	"
Troup, Noelle B, 6 Denton St, Brighton South	38.40	"	"
Turnley, Catherine A, 61 McKinnon Rd, McKinnon	48.80	"	"
Upfold, Maureen D, 10 Grace St, Beecroft, NSW	49.20	"	"
Uther, Judith, 87 Elliott St, Balmain, NSW	54.00	"	"
VFN Investments Pty Ltd, c/o K G Colhoun, 9/67 Queens Rd, Melbourne	73.60	"	"
Vaughan, Raymond A, 9 Bransby St, Embleton, WA	72.00	"	"
Versteeg, Stephen, 54 Karri Dve, Dernancourt, SA	13.20	"	"
Waldie, Ian H, PO Box 26, Woonona, NSW	54.00	"	"
Waldstein, Erna (estate of), c/o James C Barden & Co, 231 Maroubra Rd, Maroubra Junction, NSW	74.00	"	"
Walshe, Vivienne D, 678 Toorak Rd, Malvern	38.00	"	"
Walters, Elaine M, 7 Singleton Rd, North Balwyn	12.00	"	"
Walton, Valerie M, 3 Billyard Gardens, 10 Billyard Ave, Elizabeth Bay, NSW	28.80	"	"
Watts, Kenneth F, 7 Gannet St, Boronia Park, NSW	78.00	"	"
Waugh, David G, 17 Iona Ave, Toorak	15.60	"	"
Webber, Maurice J, 356 Kingsgrove Rd, Kingsgrove, NSW	256.00	"	"
Webster, Judith M, 5 Brunswick St, Walkerville, SA	158.40	"	"
Wembury Pty Limited, c/o 7th Floor, 9 O'Connell St, Sydney, NSW	84.80	"	"
Werner, John A, 1/15A Bayswater Rd, Moonah, Tas	100.00	"	"
West, Marjorie E, 6 Dunstan St, Balwyn North	10.40	"	"
Whatmore, John L (estate of), c/o A E Whatmore & G C M Gee, 16-20 Bridge St, Sydney, NSW	85.20	"	"



## Unclaimed Moneys Act 1962

## Register of Unclaimed Moneys held by the—

<i>Name of Owner on Books and Last Known Address</i>	<i>Total Amount Due to Owner</i>	<i>Description of Unclaimed Money</i>	<i>Date when Amount first became Payable</i>
\$			
COLES MYER LTD—continued			
Whinfield, Robert J, 13 Ash Gve, Oak Park	188.80	Dividend	13.10.84
White, Hilary I, 48 Catalpa Cres, Turramurra, NSW	17.60	"	"
Whitehead, Barry, 6 Ruth White Avenue, Muswellbrook, NSW	13.20	"	"
Whittaker, Dulcie M, 55 Warrigal Rd, Surrey Hills	21.60	"	"
Wigley, Kenneth W, Glen Lyon, PB Fairlie, South Canterbury, NZ	94.86	"	"
Wildwood Nominees Pty Ltd, c/o Dr M A McKenzie, 477 Waverley Rd, Chadstone	54.40	"	"
Bentley-Williams, Marie E, 10 Second Ave, Willoughby, NSW	34.80	"	"
Wilson, Ian, 73 Dallington Cres, Balga, WA	88.00	"	"
Wilson, Joan L, 13 Studley Park Rd, Kew	54.00	"	"
Wong, Sik P, 18 Perkins Rd, Jardines Lookout, Hong Kong	11.76	"	"
Woodbury, Edwin R, 52 Lothiam St, Annerley, Qld	162.18	"	"
Woodham, Georgina A, 11 Tiromoana Rd, Raumati South, Wellington, NZ	85.68	"	"
Woodman, Doris, Wyndale, Streatham Rise, Exeter, Devon, UK	34.00	"	"
Writer, Doris J, c/o Public Trust Office, GPO Box M946, Perth, WA	120.00	"	"
Yezbak, Gilbert, 5718 Fitch Rd, North Olmsted, Ohio, USA	93.50	"	"
Yik, Yoke K, 7A Conway Cres, Balwyn	28.80	"	"
Young, Ying, 8 Terrace St, Wanganui, South Otago, NZ	24.48	"	"
Allen, William T, c/o W Everson, 14 Dalrymple St, Red Hill, ACT	116.25	Debenture	30.6.84
Atkinson, Robert D, 15 Rocklynn Pl, Launceston, Tas	310.00	"	"
Fitzsimons, Norma A, Aroona Court, 10/110 Spit Rd, Mosman, NSW	77.50	"	"
Flack, John P, 6 Manhattan Square, Vermont	129.17	"	"
Hinds, Phillipa A, c/o P A Robertson, 29/48 Khartoum Rd, North Ryde, NSW	77.50	"	"
Moore, Joyce R, 41 Dargie St, Everton Park, Qld	78.75	"	"
Orr, Mabel N (estate of), c/o P Byers, 6 Tambee St, St Ives, NSW	155.00	"	"
Outhred, Myra G, 165 Serpells Rd, Templestowe	67.50	"	"
Whitehouse, Joseph H, PO, Seaforth, Qld	155.00	"	"
Wilson, Yuille, 56 Lipton Dve, Frankston	135.00	"	"
Bell, Joan M, 23A Stuart St, Longueville, NSW	2103.34	"	"
Crothers, Jean M, "Ravenscliff", 36 Kardinia Rd, Clifton Gardens, NSW	1051.67	"	"
Fitzsimons, Norma A, Aroona Court, 10/110 Spit Rd, Mosman, NSW	51.67	"	"
Morabito, Frank, 43 Franklin St, Wangaratta	1051.67	"	"
Suter, Ian M, 82 Sandford St, St Lucia, Qld	51.67	"	"
Cowlshaw, George K (estate of), c/o Bain & Company, 6-10 O'Connell St, Sydney, NSW	103.34	"	"
Carver, Helen M, c/o Robert Cran & Green, 20 Bond St, Sydney, NSW	80.00	"	"
Cope, John A, 31 Winifred St, Nunawading	20.25	"	"
Hooke, Alison M, 2/6 Mountain Gve, Kew	315.00	"	"
Johnson, Adele L M, 54 Newton Rd, Blacktown, NSW	118.13	"	"
Kimber, Richard J, 71 Statebourough St, Erindale, SA	80.00	"	"
Samuel, Andrew J, 15 Genda Crt, Mount Waverley	40.00	"	"

Form 16 (Rule 8.10)—Advertisement of Application for Winding Up—In the Supreme Court of Victoria—1986 No. Co. 449—In the matter of the Companies (Victoria) Code; and in the matter of Yorkfield Pty. Ltd.

Notice is hereby given that an application for the winding up of the abovenamed company by the Supreme Court of Victoria was on 12 June 1986 filed by 3 Point Motors Pty. Ltd. a creditor of the abovenamed company. This application is to be heard before the court in the Seventh Court, Law Courts, Lonsdale Street, Melbourne at 10.30 a.m. on 30 July 1986.

The liquidator whose appointment is sought is Mr Andrew Stewart Home of the firm of Messrs. Deloitte, Haskins and Sells of 461 Bourke Street, Melbourne.

The applicant's address is 123 Fergie Street, North Fitzroy.

The applicant's Solicitor is Messrs. Phillips & Wilkins of 823 High Street, Thornbury.

**PHILLIPS & WILKINS**  
Solicitors for the applicant

Note—Any person who intends to appear on the hearing of the application must serve on or send by post to the abovenamed solicitor notice in writing of his intention so to do. The notice must state the name and address of the person or, if a firm, the name and address of the firm, and must be signed by the person or firm, or his or their solicitor (if any), and must be served or, if posted, must be sent by post in sufficient time to be received not later than 4 o'clock in the afternoon of Tuesday, 29 July 1986 (the day before the day appointed for the hearing of the application or the Friday preceding the day appointed if the day appointed is a Monday or Tuesday following a public holiday). 3456

Companies (Victoria) Code, Section 392  
**DELTONA INVESTMENTS PTY. LTD.**  
**S.K.W.B. HOLDINGS PTY. LTD.**  
**CENTURY SPORTSWEAR PTY. LTD.**  
**CENTURY SLACKS PTY. LTD.**  
**CENTURY MANTELS PTY. LTD.**  
**CENTURY FROCKS PTY. LTD.**

Notice is hereby given that each of the above companies held a general meeting of its members on 30 June 1986 and that at each meeting the following special resolution was passed:

"That the company be wound up voluntarily."

**MURRAY DEWAR**, liquidator, 17 Landcox Street, East Brighton 3457

In the Supreme Court of Victoria—1986 No. Co. 450—In the matter of the Companies (Victoria) Code 1982; and in the matter of Caras Pty. Ltd.—Notice of Appointment of Provisional Liquidator On 24 June 1986 the Supreme Court of Victoria

appointed Tim Arthur Jonas of 80 Collins Street, Melbourne to be the liquidator of Caras Pty. Ltd. provisionally.

**MACKAY, TAYLOR & CO.**, solicitors for the applicants, 131 Kepler Street, Warrnambool 3472

**GLEN IRIS MOTORS PTY. LTD.**  
(In Voluntary Liquidation)

At an extraordinary general meeting of the company, duly convened and held at 29 Glenvale Road, Glen Iris, on 25 June 1986 at 5.00 p.m. the following resolution was passed as a special resolution:

"That the company be wound up voluntarily and that Keith James Coghlan be appointed liquidator." 3458

Companies (Victoria) Code  
**RUBYTIME INVESTMENTS PROPRIETARY LIMITED**

At a general meeting of the members of Rubytyme Investments Proprietary Limited, duly convened and held at 46 Lydiard Street South, Ballarat on 25 June 1986, it was resolved that the company be wound up voluntarily and that Ian David Lawrie of Prowse, Cook & Perrin, 46 Lydiard Street South, Ballarat be appointed liquidator.

Dated 1 July 1986

3459 **IAN DAVID LAWRIE**, Liquidator

Companies (Victoria) Code  
**LEO McMAHON & ASSOCIATES PROPRIETARY LIMITED**

At a general meeting of the members of Leo McMahon & Associates Proprietary Limited, duly convened and held at 74 Robertson Street, Sherwood, Queensland, on 26 June 1986, it was resolved that the company be wound up voluntarily and that Ian David Lawrie of Prowse, Cook & Perrin, 46 Lydiard Street South, Ballarat be appointed liquidator.

Dated 1 July 1986

3460 **IAN DAVID LAWRIE**, Liquidator

**PENGUIN SEWING COTTON PTY. LTD.**  
(In Voluntary Liquidation)

At an extraordinary General Meeting of the Company, duly convened and held at Level 18, 499 St. Kilda Road, Melbourne on 30 June 1986 at 5.30 p.m. the following resolution was passed as a Special Resolution:

"That the Company be wound up voluntarily and that Richard C. Kitchen be appointed Liquidator." 3506

**PENGUIN SYNTHETICS PTY. LTD.**

(In Voluntary Liquidation)

At an extraordinary General Meeting of the Company, duly convened and held at Level 18, 499 St. Kilda Road, Melbourne on 30 June 1986 at 5.00 p.m. the following resolution was passed as a Special Resolution:

"That the Company be wound up voluntarily and that Richard C. Kitchen be appointed Liquidator."

3507

**LOWDEN NOMINEES PTY. LIMITED**

(In Voluntary Liquidation)

Special Resolution to Wind Up

At an Extraordinary General Meeting of the abovenamed Company duly convened and held at 45 Lorraine Drive, East Burwood on 26 June 1986, the following Resolution was passed as a Special Resolution:

"That the Company be wound up voluntarily."

At the abovementioned meeting Carmel Collins was appointed Liquidator for the purpose of the winding up.

Notice is also given that after 30 days from this date, I shall proceed to distribute the assets. All creditors having any claim against the Company should furnish particulars of same by that date, otherwise I shall proceed to distribute the assets without regard to their claim.

Dated 26 June 1986

3438 C. COLLINS, Liquidator

Companies (Victoria) Code

**CARLSCOTT PTY. LTD.**

(In Liquidation)

Notice is hereby given that pursuant to section 411 of the Companies (Victoria) Code a general meeting of the members of the abovenamed Company will be held at 8 Belmont Street, Surrey Hills on Monday, 11 August 1986 at 10 a.m. for the purpose of having an account laid before them showing the manner in which the winding up has been conducted and the property of the Company disposed of and of hearing any explanation that may be given by the liquidator.

Dated 4 July 1986

3537 RONALD E. MARTIN  
Liquidator**PLASTIC DEVELOPMENT CORPORATION  
PTY. LIMITED.**

(In Voluntary Liquidation)

Special Resolution to Wind Up

At an Extraordinary General Meeting of the above named company duly convened and held at 45 Lorraine Drive, East Burwood, on 26 June 1986, the following resolution was passed as a Special Resolution:

"That the Company be wound up voluntarily"

At the abovementioned meeting Guiseppa Pulitano was appointed Liquidator for the purpose of the winding up.

Notice is also given that after 30 days from this date, I shall proceed to distribute the assets. All creditors having any claim against the Company should furnish particulars of same by that date, otherwise I shall proceed to distribute the assets without regard to their claim.

Dated 26 June 1986

3538 G. PULITANO  
Liquidator**OASIS POOLS PTY. LTD.**

(In Voluntary Liquidation)

Notice is hereby given that pursuant to section 411 of the Companies (Victoria) Code a general meeting of the members and creditors of the Company will be held at 284 Dorset Road, Boronia on Monday, 18 August 1986 at 10.00 a.m. for the purpose of having laid before them an account showing how the winding up has been conducted and the property of the Company disposed of and of hearing any explanation that may be given by the liquidator.

3539 W. H. PROMNITZ  
Liquidator**ACCPRO PTY. LTD.**

(In Voluntary Liquidation)

Notice is hereby given that pursuant to section 411 of the Companies (Victoria) Code a general meeting of the members of the Company will be held at 284 Dorset Road, Boronia on Monday, 18 August 1986 at 10.00 a.m. for the purpose of having laid before them an account showing how the winding up has been conducted and the property of the Company disposed of and of hearing any explanation that may be given by the liquidator.

3540 W. J. ASHMAN  
Liquidator

In the Supreme Court of Victoria—Application No. Co. 508 of 1986—In the matter of the Companies (Victoria) Code; and in the matter of Eighth Trenggamu Pty. Ltd.

Notice is hereby given that an application for the winding up of the abovenamed company by the Supreme Court was presented by Berwick Sand, Soil and Mini-Mix Supply Pty. Ltd. of 9 The Centre way, Pinewood Shopping Centre, Glen Waverley and that the said Application is directed to be heard before the Court sitting in the 7th Court, Law Courts, Lonsdale Street, Melbourne at 10.30 a.m. on 13 August 1986 before a Master of this Honourable Court and any creditor or contributory of the said company desiring to support or oppose the making of an order on the said application may appear at

the time of the hearing by himself or his counsel for the purpose, and a copy of the said application will be furnished to any creditor or contributory of the said company requiring the same by the undersigned on payment of the regulated charge for the same.

The Applicant's official address is 9 The Centreway, Pinewood Shopping Centre, Glen Waverley. The Applicant's solicitors are Messrs Hardy Rowson & Giampiccolo of 53 Robinson Street, Dandenong.

**HARDY ROWSON & GIAMPICCOLO**

Note: Any person who intends to appear on the Hearing of this application must serve or send by post to the abovenamed Hardy Rowson & Giampiccolo of 53 Robinson Street, Dandenong notice in writing of his/her/its/their intention so to do. The notice must state the name and address of the person or if a firm the name and address of the firm and must be signed by the person or firm or his/her/its/their solicitors (if any) and must be served or if posted, must be sent by post within sufficient time to reach the abovenamed not later than 4.00 p.m. on 12 August 1986

3541

MABEL WOODS, formerly of 2 Sunray Street, Cheltenham, but late of Tobla Lodge, 338 Bay Road, Cheltenham in the State of Victoria, widow, deceased

Creditors, next of kin and others having claims in respect of the estate of the abovenamed deceased who died on 8 February 1986 are required to send particulars of their claims to the executors Ronald Corbett of 70 Castlewood Street, East Bentleigh and Mavis Chilvers of 129 Overport Road, Frankston by 10 September 1986 after which date they may convey or distribute the assets having regard only to the claims of which they then have notice.

TURNER, NESS & DAVIS, solicitors, 12 Batman Street, Melbourne

3524

EVELYN ELIZABETH VALENTINE, formerly of 28 Mary Street, St. Kilda, but late of 53 Jackson Street, St. Kilda, pensioner, deceased

Creditors, next of kin and others having claims in respect of the estate of the deceased who died on 17 May 1986 are required by the legal personal representative Leonard Edgar Grinstead of 39 Park Street, South Melbourne, Salvation Army Officer to send particulars to him by 21 September 1986 after which date he will distribute the assets having regard only to the claims of which he has notice.

E. P. JOHNSON & DAVIES, solicitors, of 257 Collins Street, Melbourne

3525

Creditors, next of kin and other persons having claims against the estate of Ian Paull Fiddian late of 107 Leopold Street, South Yarra in the State of Victoria, retired university officer, who died on 3 May 1986 are required by the executrix Halinka Cecylia Anna Fiddian of 107 Leopold Street, South

Yarra in the said State to send particulars of their claims to her care of the undersigned by 9 September 1986 after which date she will distribute the estate having regard only to the claims of which she then has notice.

JOHN D. MUSTOW & CO., solicitors, 105 Queen Street, Melbourne

3526

ROBERT BOSTON ODGERS, late of 152 Maryvale Road, Morwell, in the State of Victoria, retired, deceased

Creditors, next of kin and others having claims in respect of the estate of the deceased (who died on 19 March 1986) are required by the executrix Catherine Florence Odgers of 152 Maryvale Road, Morwell in the said State to send particulars to her care of the undermentioned solicitors by 8 September 1986 after which date the executrix may convey or distribute the assets having regard only to the claims of which she then has notice.

SLATER & GORDON, solicitors, of 37 Elgin Street, Morwell

3490

WILLIAM DONOVAN JOYNT, late of Centennial House, 15 Raleigh Street, Windsor, in the State of Victoria, gentleman, deceased

Creditors, next of kin and others having claims in respect of the estate of the deceased who died on 5 May 1986 are required by The Perpetual Executors and Trustees Association of Australia Limited of 50 Queen Street, Melbourne aforesaid the applicant for a grant of administration, to send particulars of their claims to the said applicant in the care of the said company by 30 September 1986 after which date it will convey or distribute the assets having regard only to the claims of which it then has notice.

MOULES, solicitors, 140 William Street, Melbourne

3491

EILEEN MARY GRIMES, late of "Parkville", 12/353 Kooyong Road, Elsternwick, Victoria, retired, deceased

Creditors, next of kin and others having claims in respect of the estate of the deceased who died on 22 October 1985 are required by Bryan David Connor, trust manager of The New Zealand Insurance Company Ltd. of 20 Bond Street, Sydney, New South Wales, the applicant for a grant of representation to send particulars thereof to him before 17 September 1986, after which date he may distribute the assets of the deceased having regard only to the claims of which he then has notice.

FREDERICK OWEN & ASSOCIATES, solicitors, 450 Little Collins Street, Melbourne

3492

HELEN RUTH GILLINGHAM (also known as Bertha Helen Ruth Gillingham), late of Unit 2, 490 Mitcham Road, Mitcham, widow, deceased

Creditors, next of kin and others having claims with respect of the estate of the deceased who died on 20 November 1985 are required by the trustees, Gwendoline Mabel Moore of 30 Suda Avenue, Ringwood and Hazel Clarice Creek of 3 Loveneer Grove, Ballarat East, married women, to send particulars to them care of the undermentioned solicitors by 10 September 1986, after which date the trustees may convey or distribute the assets having regard only to the claims of which they then have notice.

McCRACKEN & McCRACKEN, 150 Queen Street, Melbourne 3493

HENRY MCGREGOR HANCOCK, late of 22 Henwood Street, Blackburn, in the State of Victoria, gentleman, deceased

Creditors, next of kin and others having claims in respect of the estate of the deceased who died on 4 April 1986 are required by the executors, Peggy McWhinney of 48 Raleigh Street, Forest Hill, widow and Brian Redmond Smyth of 900 Main Road, Eltham, solicitor, to send particulars to the undermentioned firm by 18 September 1986, after which date the said executors may convey or distribute the assets having regard to the claims of which notice has then been given.

SETON WILLIAMS & SMYTH, solicitors, 900 Main Road, Eltham 3494

Creditors, next of kin and others having claims in respect of the Estate of Emily May Warren late of 44 McDonald Street, East Geelong, widow deceased who died on 18 March 1986 are required to send particulars of their claims to the Executor Robert Douglas James Taylor care of the undersigned Solicitors before 10 September 1986 after which date the assets of the estate will be distributed having regard only to the claims of which the Executor then has notice.

HARWOOD & PINCOTT, solicitors, 77 Moorabool Street, Geelong 3444

In the Will and Estate of Colin Campbell Martin, late of Unit 2, 6-10 Lennox Street, Hawthorn, in the State of Victoria, marketing consultant, deceased

Creditors, next of kin and others having claims against the Estate of the abovenamed deceased who died on 30 December 1982 should send particulars of their claim to John Garde the Administrator with the Will annexed of the unadministered estate of Colin Campbell Martin deceased, care of the undermentioned Solicitors by 3 October 1986, after which date he will distribute the assets having regard only to the claims of which he then has notice.

ADAMS & GARDE, solicitors, 11A Central Avenue, Moorabbin 3445

Creditors, next of kin and others having claims against the Estate of Margaret Dorothy Laing (formerly Margaret Dorothy Axten) late of 11/75 Queens Road, Melbourne in the State of Victoria Housekeeper deceased who died on 10 April 1986 probate of whose Will was granted to Helen Emily Bernard of 70 Harvey Street East Woodville Park in the State of South Australia a member of the religious Order known as Little Sisters of Jesus are to send particulars of such claims to the undersigned at his office hereunder mentioned by 9 September 1986 after which date the said Helen Emily Bernard will distribute the assets having regard only to the claims of which she shall then have had notice.

JOHN KEATING & ASSOCIATES, solicitors, 191 Greville Street, Prahran 3446

HAROLD STEPHENSON, formerly of 15 Yarra Grove, Hawthorn, but late of 74 Seaview Avenue, Safety Beach, engineer, deceased

Creditors, next of kin and others having claims in respect of the estate of the deceased who died on 23 February 1986 are required by the legal personal representative, Ruby Victoria Stephenson of 15 Yarra Grove, Hawthorn, widow, to send particulars to her by 14 September 1986, after which date she will distribute the assets having regard only to the claims of which she has notice.

E. P. JOHNSON & DAVIES, of 257 Collins Street, Melbourne 3488

KEITH ROBERT DAVID BAIN, late of 24 Alfred Street, Kew, in the State of Victoria, gentleman, deceased

Creditors, next of kin and others having claims in respect of the estate of the deceased who died on 16 April 1986 are required by the Perpetual Executors & Trustees Association of Australia Ltd. of 50 Queen Street, Melbourne and Mary Barbara Bain of 24 Alfred Street, Kew, widow, the applicants for a grant of an administration, to send particulars of their claims to the said applicants in the care of the said company by 14 July 1986, after which date they will convey or distribute the assets having regard only to the claims of which they then have notice.

KIDDLE BRIGGS & WILLOX, solicitors, 459 Collins Street, Melbourne 3489

Creditors, next of kin and others having claims in respect of the estate of Marjorie Fraser, late of 16 Percival Street, Oak Park, widow, deceased, who died on 3 March 1986, are to send the particulars of their claims to ANZ Executors & Trustee Company Limited of 94 Queen Street, Melbourne by 11 September 1986, after which date it will distribute the assets having regard only to the claims of which it then has notice.

3498

SIMON PAUL TOWELL (deceased), late of 13 Victoria Street, St James, W.A., died on 1 April 1986

Any persons claiming to be dependent upon the deceased are requested to send particulars of their claims to "Life Claims Department, Australian Eagle Ins. Co. Ltd, G.P.O. Box 1883R, Melbourne, 3001" within 2 months from the date of this notice, after which date the deceased's entitlement will be distributed in accordance with the provisions of the Eagle Retirement Fund Trust Deed, having regard only to the claims which have been notified. 3440

MARY CECILIA QUINN, late of Whitehall Special Accommodation House, 1234 Nepean Highway, Mentone, but formerly of 161 Power Street, Hawthorn, deceased

Creditors, next of kin and others having claims in respect of the estate of the deceased, who died on 29 April 1985 are required by the National Trustees Executors and Agency Company of Australasia Limited, of 95 Queen Street, Melbourne to send particulars to it within two calendar months of the date of this notice after which date the trustees may convey or distribute the assets, having regard only to the claims of which it then has notice.

SEPTIMUS JONES & LEE, solicitors, 257 Collins Street, Melbourne 3441

OLGA HARFOUCHE, late of Unit 3, 74 Anderson Road, Sunshine, in the State of Victoria, widow, formerly married woman, deceased

Creditors, next of kin and others having claims in respect of the estate of the deceased who died on 11 March 1986 at Sunshine aforesaid are required by the trustee, National Trustees Executors and Agency Company of Australasia Limited of 95 Queen Street, Melbourne in the said State to send particulars to it by 19 September 1986 after which date the trustee may convey or distribute the assets having regard only to the claims of which it then has notice.

Dated 1 July 1986

J. McD. JONES & PURCELL, 76 Dudley Street, Melbourne West, solicitors for the trustee 3442

TEWFIC HARFOUCHE, late of Unit 3, 74 Anderson Road, Sunshine, in the State of Victoria, retired insurance representative, deceased

Creditors, next of kin and others having claims in respect of the estate of the deceased who died on 1 March 1986 at Sunshine aforesaid are required by the trustee, National Trustees Executors and Agency Company of Australasia Limited of 95 Queen Street, Melbourne in the said State to send particulars to it by 19 September 1986 after which date the trustee may convey or distribute the assets having regard only to the claims of which it then has notice.

Dated 1 July 1986

J. McD. JONES & PURCELL, 76 Dudley Street, Melbourne West, solicitors for the trustee 3443

GERTRUDE MABEL ATKINSON (also known as Mabel Gertrude Atkinson), late of Elgar Private Nursing Home, 366 Elgar Road, Box Hill in the State of Victoria, widow, deceased

Creditors, next of kin and others having claims in respect of the estate of the deceased who died on 18 February 1986 are required by the personal representative Arnold Percy Atkinson, to send particulars to him care of the undersigned solicitors by 10 September 1986, after which date the personal representative may convey or distribute the assets having regard only to the claims of which he then has notice.

TESTART, ROBINSON & PITTS, solicitors, 942-946 Whitehorse Road, Box Hill 3475

Creditors, next of kin and others having claims in respect of the estate of Elizabeth Helen Fisher late of 31 Ian Grove, Mount Waverley, programmer, deceased, who died on 24 November 1985 are to send particulars of their claims to the administrator of the estate, James Gambit care of the undersigned by 10 September 1986, after which date he will distribute the assets having regard only to the claims of which he then has notice.

EGAN LOBB & WALKER, solicitors, 5 Hamilton Place, Mount Waverley 3476

ANTHONY DAVID HAND (deceased), late of 3 Cadell Court, Hope Valley, South Australia, died on 1 January 1986

Any persons claiming to be dependent upon the deceased are requested to send particulars of their claims to "Life Claims Department, Australian Eagle Ins. Co. Ltd., G.P.O. Box 1883R, Melbourne 3001" within two months from the date of this notice, after which date the deceased's entitlement will be distributed in accordance with the provisions of the Eagle Superannuation Trust Trust Deed, having regard only to the claims which have been notified.

3477

MARY ALICE CATE, late of 22 Ruby Street, East Burwood in the State of Victoria, widow, deceased

Creditors, next of kin and others having claims in respect of the estate of the deceased who died on 15 July 1985 are required by A.N.Z. Executors and Trustee Company Limited of 94 Queen Street, Melbourne in the said State, being the executors to whom a grant of probate of the will of the abovenamed deceased has been granted, to send particulars of their claim to the executors c/o A.N.Z. Executors and Trustee Company Limited of 94 Queen Street, Melbourne, aforesaid by no later than sixty (60) days from the date of this advertisement after which the Executors will convey or distribute the assets having regard only to the claims of which the executors then have notice.

J. N. ZIGOURAS & CO., solicitors, 473A Whitehorse Road, Mitcham 3516

LAURENCE VICTOR LINDSAY, late of 133 Vincent Road, Wangaratta in the State of Victoria, dealer, deceased

Creditors, next of kin and others having claims in respect of the estate of the deceased, who died on 19 January 1986 are required by Mary Esther Putt of Hill Place, Ebdon in the said State, school teacher and ANZ Executors and Trustee Company Limited of 94 Queen Street, Melbourne in the said State, the executors of the estate of the said deceased, to send particulars of such claims to them in care of ANZ Executors & Trustee Co. Ltd., G.P.O. Box 389D, Melbourne by 4 September 1986, after which date they will convey and distribute the assets, having regards only to the claims of which they then have notice.

McSWINEYS, solicitors of 57 Reid Street, Wangaratta 3479

Creditors, next of kin and others having claims in respect of the estate of Ethel May Stapleton late of 27 Bobs Street, Bendigo, widow deceased who died on 1 June 1986 are required to send particulars of their claims to the executor National Trustees Executors and Agency Company of Australasia Limited of 46 Queen Street, Bendigo by 24 September 1986 after which date it will distribute the assets having regard only to the claims of which it then has notice.

ROGERS & EVERY, solicitors, 71 Bull Street, Bendigo 3513

ARTHUR PATRICK DOBBYN, late of 78 Havlin Street, Bendigo, gentleman, deceased

Creditors, next of kin and others having claims against the estate of the abovenamed deceased are required by the executors thereof Norman James Dobbyn of 6 Echuca Road, Mooroopna, transport driver and Helene Hamilton Dobbyn of Numurkah Road, Shepparton, typist/clerk to send particulars thereof to them care of the undermentioned solicitors on or before 8 September 1986 after which date they will distribute the assets of the said estate having regard only to the claims of which they then have notice.

Dated 1 July 1986

HYETT ELLINGHAUS JOHN MORRISON SUTTON, solicitors, 51 Bull Street, Bendigo 3514

Creditors, next of kin and others having claims in respect of the estate of Bridget Eileen McMinn, late of 11 Begg Street, Kyneton, widow, deceased, who died on 20 June 1986, and by whose will Mary Josephine Brown, of 177 Lambie Street, Tumut, New South Wales, married woman, was appointed executor, are required to send particulars of their claims to the said executor care of the undersigned solicitors before 10 September 1986, after which date she will distribute the assets having regard only to the claims of which she shall then have had notice.

PALMER, STEVENS & RENNICK, solicitors, Kyneton 3480

MARGARET MACKENZIE, formerly of 7 Whittig Street, Doncaster, but late of 79/37 View Mount Road, Glen Waverley, widow, deceased

Creditors, next of kin and others having claims in respect of the estate of the deceased, who died on 18 May 1986, are required by the executor, Alexander Fraser Mackenzie, manager, of 8 Marilyn Street, Doncaster, to send particulars to the undermentioned firm by 18 September 1986, after which date the said executor may convey or distribute the assets having regard to the claims of which notice has by then been given.

SETON WILLIAMS & SMYTH, solicitors, 900 Main Road, Eltham 3495

JOHN DENIS CHRISTIAN, late of Christian Road, Cottlesbridge, farmer, deceased

Creditors, next of kin and others having claims in respect of the estate of the deceased, who died on 8 May 1986 are required by the executors, Kevin John Christian, farmer, of Christian Road, Cottlesbridge and Charles Denis William Christian, farmer, of "Almond Grove", Byawatha, to send particulars to the undermentioned firm by 18 September 1986, after which date the said executors may convey or distribute the assets having regard to the claims of which notice has by then been given.

SETON WILLIAMS & SMYTH, solicitors, 900 Main Road, Eltham 3496

Creditors, next of kin and others having claims against the estate of Thomas George Riddell, late of 1855 Malvern Road, East Melbourne, in the State of Victoria, widower, deceased, who died on 5 March 1986 and probate of whose will was granted by the Supreme Court of Victoria in its Probate jurisdiction on 23 June 1986 are required to send particulars of their claims to the executors, The Union-Fidelity Trustee Company of Australia Ltd. and William James Riddell, care of 100 Exhibition Street, Melbourne, by 5 September 1986, after which date the executors will distribute the assets of the estate having regard only to the claims of which it shall then have had notice.

ELLISON HEWISON & WHITEHEAD, solicitors of 379 Collins Street, Melbourne 3497

JESSIE McLEOD LANG, late of the Ouyen Nursing Home, Ouyen, in the State of Victoria, widow, deceased

Creditors, next of kin and other persons having claims against the estate of the said deceased who died on 21 May 1986 are required to send particulars of same to Ian McLeod Lang, the eldest son of the deceased in care of the undersigned on or before 1 September 1986, after which date he will distribute the assets having regard only to the claims of which he then has notice.

DWYER, BENNETT & MAHON, barristers and solicitors, 194-208 Beveridge Street, Swan Hill 3478

**RUBY FLORENCE WALLEY**, late of 197 Swanston Street, Geelong, widow, deceased

Creditors, next of kin and others having claims in respect of the estate of the deceased, who died on 23 May 1986 are required by the trustees, Edna Lorraine James of 20 Prospect Avenue, Belmont, Jean Elizabeth Dunn, formerly of 31A Thompson Street, Belmont, Geelong and George James Walley of 114 Elizabeth Street, West Geelong to send particulars to them by 7 September 1986, after which date the trustees may convey or distribute the assets having regard only to the claims of which they then have notice.

Dated 1 July 1986

**MESSRS. AINSWORTH & CO.**, solicitors of 117 Yarra Street, Geelong 3481

**ALFRED NORMAN TEPPER** formerly of Speewa in the State of New South Wales, but late of Hayes Road, Lake Boga in the State of Victoria, retired, deceased (who died on 16 December 1985)

Creditors, next of kin and all other persons having claims against the estate of the deceased are required by the executors of the will, Stephen Paul Jager and Rhonda Dianne Kelly, to send particulars to them care of the undersigned on or before 11 September 1986, after which date they will distribute the assets having regard only to the claims of which they then have notice.

**GARDEN & GREEN**, solicitors, 4 McCallum Street, Swan Hill 3515

**MALCOLM JOHN THOMAS** (deceased), late of 1 Satinay Street, Keperra, Queensland, died on 6 May 1986

Any persons claiming to be dependent upon the deceased are requested to send particulars of their claims to "Life Claims Department, Australian Eagle Ins. Co. Ltd., G.P.O. Box 1883R, Melbourne, 3001" within two months from the date of this notice, after which date the deceased's entitlement will be distributed in accordance with the provisions of the Eagle Retirement Fund Trust Deed, having regard only to the claims which have been notified. 3297

**EDNA MARGARET OLDFIELD**, late of 34 Clyde Street, St. Kilda, retired, deceased

Creditors, next of kin and others having claims in respect of the estate of the deceased, who died on 10 April 1986, are required by the trustee, National Trustees Executors and Agency Company of Australasia Limited, of 95 Queen Street, Melbourne, to send particulars to it by 16 September 1986 after which date the trustee may convey or distribute the assets, having regard only to the claims of which it then has notice.

**HAMILTONS**, solicitors and notary, 220 Clarendon Street, South Melbourne 3521

Creditors, next of kin and all other persons having claims against the estate of Archibald Ikin late of 17 Cole Street, Elwood, deceased who died on 5 January 1986, are required by the executors Gladys May Ikin of 17 Cole Street, Elwood in the State of Victoria, widow and Godfrey Abraham Cohen of 1 St. Ninians Court, Brighton in the said State, gentleman to send particulars of their claims to them care of the undersigned solicitors by 23 September 1986 after which date they may convey or distribute the assets having regard only to the claims of which they then have notice.

**COHENS FRENKEL KEFFORD NEW**, solicitors of 114 William Street, Melbourne 3517

**JENNIFER ANNE LANYON**, late of 54 Ford Street, Newport, in the State of Victoria, school teacher, deceased

Creditors, next of kin and other persons having claims against the estate of the said deceased who died on 20 May 1986 are required to send particulars of same to the administrator Norman Scott Lanyon in care of the undersigned on or before 19 September 1986 after which date he will distribute the assets having regard only to the claims of which he then has notice.

**HERCULES & WORLAND**, barristers and solicitors, 130 Godfrey Street, Boort 3518

Creditors, next of kin and others having claims in respect of the estate of Margaret Law Forrester Hunt late of 2 Radcliff Avenue Cheltenham widow deceased who died on 2 May 1986 are to send particulars of their claims to The Equity Trustees Executors and Agency Company Limited of 472 Bourke Street Melbourne by 17 September 1986 after which date it will distribute the assets having regard only to the claims of which it then has notice.

**AITKEN WALKER & STRACHAN**, solicitors, 114 William Street, Melbourne 3519

**DOROTHY JOAN CARTER**, late of Wartook, in Victoria, farmer, deceased

Creditors, next of kin and others having claims in respect of the estate of the deceased who died on 20 December 1985, are required by the personal representative Verna Lesley Baird of 92 Natimuk Road Horsham to send particulars to her care of the undermentioned solicitors by 30 September 1986, after which date the personal representative may convey or distribute the assets having regard only to the claims of which she then has notice.

Dated 30 June 1986

**POWER & BENNETT**, solicitors, 12 Pynsent Street, Horsham, solicitors for the personal representative 3520



Creditors, next of kin and others having claims in respect of the will of Giuseppe Pepi late of 11 Provost Street, North Melbourne, retired farmer, deceased, who died on 14 February 1986 are requested to send particulars of their claims to the executor Carmela Garbuio (in the will called Carmela Carbuio) care of the undermentioned solicitor by 15 September 1986, after which date she will distribute the assets having regard only as to the claims of which she then has notice.

EDWARD CURMI, solicitor, 440 Victoria Street,  
North Melbourne 3465

Creditors, next of kin and others having claims in respect of the estate of Ella May Jervis, late of 47 Orlando Street, Hampton, widow deceased, who died on 22 May 1986 are to send the particulars of their claims to ANZ Executors & Trustee Company Limited of 94 Queen Street, Melbourne by 11 September 1986 after which date it will distribute the assets having regard only to the claims of which it then has notice.

3522

PEARL BINNS, late of Nhill, in the State of  
Victoria, widow, deceased

Creditors, next of kin and others having claims in respect of the estate of the deceased who died on 29 April 1986 are required by the trustees Ronald Jack Binns of 2 William Street, Nhill aforesaid Electrical Serviceman and John Matheson Hobday of 30 Victoria Street, Nhill aforesaid solicitor to send particulars to them care of the undersigned by 17 October 1986 after which date the trustees may convey or distribute the assets having regard only to the claims of which they then have notice.

Dated 4 July 1986

HOBDAY & LIPSHUT, 30 Victoria Street, Nhill,  
solicitors for the said trustees 3523

HILDA BARBARA BEDDISON (usually known as Barbara Hilda Beddison) late of 5 Diane Crescent, Mooroolbark in the State of Victoria retired, deceased

Creditors, next of kin and all others having claims in respect of the Estate of the Deceased who died on 30 April 1986 at Heidelberg in the State of Victoria are required by the Trustee National Trustees Executors and Agency Company of Australasia Limited of 95 Queen Street, Melbourne in the State of Victoria to send particulars of such claims to it by 17 September 1986 after which date the Trustee may convey or distribute the assets having regard only to the claims of which it then has notice.

Dated 8 July 1986.

WILLIAMS, WINTER & HIGGS, solicitors, 90  
Queen Street, Melbourne. 3555

Creditors, next of kin and others having claims in respect of the Estate of Marion Thompson late of 8 Seaview Avenue Bentleigh in the State of Victoria, widow, deceased who died on 27 February 1986 are to send particulars of their claims to John Graham Thompson of 8 Byron Street, Canterbury in the State of Victoria Sales Representative care of the undermentioned Solicitors by 9 September 1986 after which date he will distribute the assets having regard only to the claims to which he then has notice.

REGINALD C. BUTLER & CO., solicitors, 312  
Centre Road, Bentleigh 3544

Creditors, next of kin and others having claims in respect of the estate of Roy James Alexander late of Lot 32 South Gippsland Highway, Cranbourne, Gentleman deceased, are required to send particulars of their claims to the executors, Graeme Winston Alexander and Frederick Archdale Lester care of Lester, Fielden & Faraone, Solicitors, 14 Haughton Road, Oakleigh by 9 September 1986 after which date they will distribute the assets having regard only to the claims of which they then have notice.

LESTER, FIELDEN & FARAONE, solicitors, 14  
Haughton Road, Oakleigh 3545

JOSEPH THOMAS TAYLOR, late of 3/3 Ravens  
Grove East St. Kilda retired clerk deceased

Creditors next of kin and others having claims in respect of the deceased who died on 5 May 1986 are required by the trustee National Trustees Executors and Agency Company of Australasia Limited of 95 Queen Street, Melbourne to send particulars to it by 19 September 1986 after which date the trustee may convey or distribute the assets having regard only to the claims of which it then has notice.

D. L. McNAMARA, LL.B., solicitor, 19 Grey Street,  
St. Kilda 3546

EMILY ROSETTA MARTIN, late of 45 Main,  
Street, Thomastown, in the State of Victoria,  
pensioner, deceased.

Creditors, next of kin and others having claims in respect of the estate of the deceased who died on 16 May 1985, are required by the Executor, Harold Wartime Martin, care of Arthur J. Dines & Co., Solicitors of 2A Highlands Road, Thomastown, in the said State, to send particulars to him by 30 September 1986, after which date the Executor may convey or distribute the assets having regard only to claims of which he then has notice.

Dated 7 July 1986

ARTHUR J. DINES & CO., solicitors of 2A  
Highlands Road, Thomastown 3551

**MATHILDA BERTHA ROGASCH**, late of Rainbow in the State of Victoria

Creditors, next of kin, and others having claims in respect of the estate of the deceased, who died on 30 March 1985 are required by the personal representatives, John Henry Davis, Garage Proprietor and John Pasco, Newsagent, both of Rainbow to send particulars them in care of the undermentioned Solicitors, by 1 October 1986 after which date the personal representatives may convey or distribute the assets, having regard only to the claims of which he then has notice.

**O'HAIRE & O'HAIRE**, solicitors, 9 Federal Street, Rainbow 3548

Creditors, next of kin and others having claims in respect of the Estate of Thomas William Reynolds late of 13A Gavin Street, Moorabbin in the State of Victoria, Gentleman deceased who died on 26 February 1986 are required by the Executors of the Estate, Kevin Stanley Tragear and David Charles Story, Solicitors, both of 39 Melrose Street, Sandringham in the said State, to send particulars of their claims in writing care of the undermentioned Solicitors by 15 August 1986 after which date they will distribute the assets having regard only to the claims of which they then have notice.

**TRAGEAR, STORY & TELFORD**, solicitors of 39 Melrose Street, Sandringham 3549

**THOMAS MURRAY GRAY**, late of High Street, Mansfield retired labourer deceased

Creditors, next of kin and others having claims in respect of the deceased who died on 16 May 1986 are required by his Trustees, Thomas Michael Rodney Ryan and William Henderson Glen both of 9 High Street, Mansfield, Solicitors, to send particulars to them care of the undermentioned firm of solicitors by 15 September 1986 after which date the Trustees may convey and distribute the assets having regard only to the claims of which they then have notice.

**MAL. RYAN, JACKSON & GLEN**, 9 High Street, Mansfield, Solicitors for the Trustees 3550

Creditors, next of kin and others having claims in respect of the estate of Stanley Marshall Smith late of 18 Holloway Street, Brunswick, in the State of Victoria, gentleman, deceased, who died on 8 April 1986 are to send particulars of their claims to the executrix Myrtle Smith care of the undermentioned solicitors by 9 September 1986 after which date the executrix will distribute the assets having regard only to the claims of which she then has notice.

**LE GRAND, RANGLES, ADAMS & CO.**, 636 Sydney Road, Brunswick, the solicitors acting herein. 3554

Creditors, next of kin and others having claims against the Estate of Eileen Canny, late of 112 Cochrane Street, Gardenvale, home duties, deceased who died on 20 February 1986 are required by Anne Elizabeth Lafferty, the Executrix, to send particulars of their claims to her care of the undermentioned solicitors, by 15 September 1986 after which date the Executrix will convey or distribute the Estate of the said deceased having regard only to the claims of which she then has notice.

**PHARR, JESSOP & KOMESAROFF**, Suite 13, 285 Carlisle Street, Balaclava, solicitors for the estate. 3552

Creditors, next of kin and others having claims in respect of the estate of Linda Tocknell, late of 18 Sheffield Street, West Brunswick, in the State of Victoria, widow, deceased, who died on 3 June 1986 are to send particulars of their claims to the executor Peter John Randles care of the undermentioned solicitors by 9 September 1986 after which date the executor will distribute the assets having regard only to the claims of which he then has notice.

**LE GRAND, RANGLES, ADAMS & CO.**, 636 Sydney Road, Brunswick, the solicitors acting herein. 3553

Creditors next of kin and others having claims in respect of the Will of Carmelo Vella late of 120 Sixth Avenue, North Altona; retired, deceased who died on 28 March 1986 are requested to send particulars of their claims to the Executors John Vella (in the Will called James) and Gregory Sacco, c/o the undermentioned Solicitor by 23 September 1986 after which date they will distribute the assets having regard only as to the claims of which they then have notice.

**EDWARD CURMI**, solicitor, 440 Victoria Street, North Melbourne 3547

In the Supreme Court of the State of Victoria  
SALE BY THE SHERIFF

On 14 August 1986 at 2.30 p.m. at the Sheriff's Office, Writs and Warrants Division, 287 Springvale Road, Glen Waverley (unless process be stayed or satisfied).

All the estate and interest (if any) in and to the following:

David James and Elizabeth James of 41 Male Street, Brighton, shown on Certificate of Title as David William James and Elizabeth Molly James, joint proprietors of an estate in fee simple in the land described in the Certificate of Title Volume 3529 Folio 699 upon which is erected a dwelling and known as 41 Male Street, Brighton.

Registered Mortgages K68738, K81668 and L846147w affect the said estate and interest.

Fourth Gozbarb Pty. Ltd. of 232 Brunswick Road, West Brunswick, proprietor of an estate in fee simple in the land described in Certificate of Title Volume 5056 Folio 067 upon which is erected a partly constructed dwelling and known as 29 Wimba Avenue, Kew.

Registered Mortgages K686944, K686945 and Caveats M276214J, M287743H affect the said real estate and interest.

Mr L. Simmonds and Mrs M. Simmonds, shown on Certificate of Title as Leo Simon Simmonds and Marita Anne Louise Simmonds of 12 Chelbara Court, Chelsea, as joint proprietors of an estate in fee simple in the land described in Certificate of Title Volume 9373 Folio 825 upon which is erected a dwelling known as 13 Swallow Court, Patterson Lakes.

Registered Mortgages L346839A, L346840A and Caveat M021344D affect the said estate and interest.

Any mortgages and/or other dealings specified may affect the said estate and interest.

Terms—Cash only  
3529 A. STANLEY, Sheriff's Officer

In the Supreme Court of the State of Victoria  
SALE BY THE SHERIFF

On 21 August 1986 at 2.30 p.m. at the Sheriff's Office, Writs and Warrants Division, 287 Springvale Road, Glen Waverley (unless process be stayed or satisfied).

All the estate and interest (if any) in and to the following:

Helen Elizabeth Burke, of 8 Johansons Road, Warrandyte, as registered proprietor in the land described in Memorial of Conveyance Book 792 No. 906. The land is known as No. 113 Barkly Street, St. Kilda, upon which is erected a dwelling house.

Mortgage No. 149 Book 844 affects the said estate and interest.

Mr Cane Petreski, of 104 Monash Street, Lalor, proprietor of an estate in fee simple in the land described in the Certificate of Title Volume 8870 Folio 948 upon which is erected a dwelling and known as 104 Monash Street, Lalor.

Registered Mortgage G560834 and Caveats G234429 and K631657 affects the said estate and interest.

Any mortgages and/or other dealings specified may affect the said estate and interest.

Terms—Cash only  
3530 A. STANLEY, Sheriff's Officer

In the Supreme Court of the State of Victoria  
SALE BY THE SHERIFF

On 21 August 1986 at 2.30 p.m. at Kilmore Police Station (unless process be stayed or satisfied).

All the estate and interest (if any) of Graeme Fletcher of 80 Frankston Road, Dandenong, shown on Certificate of Title as Graham Fletcher, joint proprietor with Lorilee Fletcher of an estate in fee simple in the land described in Certificate of Title Volume 8894 Folio 376 upon which is erected a dwelling and known as Lot 4 Duffy Street, Kilmore East. The property is approximately 15 acres and is the first block and house on the right in Duffy Street after turning left from Harrington Street.

Registered Mortgages H58240, H439501 and Caveat J233351 affect the said estate and interest.

Terms—Cash only  
3531 A. STANLEY, Sheriff's Officer

In the Supreme Court of the State of Victoria  
SALE BY THE SHERIFF

On 7 August 1986 at 2.30 p.m. at the Sheriff's Office, 287 Springvale Road, Glen Waverley (unless process be stayed or satisfied).

All the estate and interest (if any) of Mr David Burgess of Lot 21 Weeroona Road, Baxter, shown on Certificate of Title as David Wallace Burgess as joint proprietor with Susan Jane Lane of an estate in fee simple in the land described in Certificate of Title Volume 6101 Folio 196 upon which is erected a dwelling known as Lot 21 Weeroona Road, Baxter.

Registered caveat K812101 affects the said estate and interest.

Terms—Cash only  
3499 A. STANLEY, Sheriff's Officer

LATE NOTICES

*Police Regulation (Amendment) Act 1985*  
(No. 10250)

COMMENCEMENT OF CERTAIN  
PROVISIONS

PROCLAMATION

By His Excellency the Governor of the State of Victoria and its Dependencies in the Commonwealth of Australia, &c., &c., &c.

Whereas by an Act of the Parliament of Victoria passed in the thirty-fourth year of the reign of Her Majesty Queen Elizabeth the Second, entitled the *Police Regulation (Amendment) Act 1985* (No. 10250), it is enacted that the Act comes into operation on a day or days to be proclaimed:

And whereas sections 1 to 5, 7 to 9 and 11 to 21 have been previously proclaimed to come into operation:

Now therefore I, the Governor of the State of Victoria, by and with the advice of the Executive Council, hereby fix Monday 14 July 1986, as the day on which section 10 of the *Police Regulation (Amendment) Act 1985* (No. 10250) shall come into operation.

Given under my Hand and the Seal of the State of Victoria aforesaid, at Melbourne, this eighth day of July in the year of our Lord One thousand nine hundred and eighty-six and in the thirty-fifth year of the reign of Her Majesty Queen Elizabeth the Second, Queen of Australia.

(L.S.) J. DAVIS MCCAUGHEY

By His Excellency's Command

C. R. T. MATHEWS  
Minister for Police and Emergency Services  
GOD SAVE THE QUEEN!

Department of Industry, Technology and Resources

INTENTION TO GRANT A MINING LEASE

No. 1306; B. R. McLean and D. R. McLean; 255.7 ha, Parish of Toombullup.

MINING LEASE GRANTED

No. 1205; New Matlock Gold Mine Pty. Ltd.; 200 ha, Parishes of Moolpah, Matlock and Sandler.

MINING LEASE RENEWED

No. 179-1; P. C. Poole, E. Poole and B. Prothero; 31.28 ha, Parish of Kevington.

APPLICATION FOR MINING LEASE REFUSED

No. 1379; Sandhurst Mining NL; approx. 266 ha, Parishes of Buninyong and Yarrowee.

MINING LEASE DECLARED VOID

No. 219; R. G. Sidebottom and B. A. Bullock; 7.3728 ha, Parish of Derrill.

APPLICATION FOR DEVELOPMENT LEASE DECLARED ABANDONED

No. 169; H. Smith; 231.5 ha, Parish of Blackwood.

APPLICATION FOR DEVELOPMENT LEASE REFUSED

No. 189; Hanette Pty. Ltd.; 300 ha, Parishes of Noorrong and Tallandon.

INTENTION TO GRANT A PROSPECTING AREA LICENCE

No. 133; Kempson Tunbridge Mining Pty. Ltd.; 195 ha, Parish of Moliagul.

APPLICATION FOR TAILINGS REMOVAL LICENCE REFUSED

No. 4922; J. Masterson, to remove tailings from the Cassius Dump in the Parish of Jirnkee.

TAILINGS REMOVAL LICENCE (TO TREAT ELSEWHERE) EXPIRED

No. 4654; Ephratah Nominees Pty. Ltd.; to remove for the purpose of treatment elsewhere tailings situated on the north and south of the southern boundary of the Township of Costerfield.

APPLICATION FOR EXPLORATION LICENCE REFUSED

No. 1507; Carlton Textile (Exports) Pty. Ltd.; 1.5 km<sup>2</sup>, County of Talbot.

EXTRACTIVE INDUSTRY LICENCE GRANTED

No. 1256; Shire of Rochester; 4.5 ha, Parish of Nanneella.

APPLICATION FOR EXTRACTIVE INDUSTRY LICENCE DECLARED ABANDONED

No. 1301; R. E. Thompson and G. R. Thompson; 20 ha, Parish of Tyabb.

APPLICATION FOR RENEWAL OF EXTRACTIVE INDUSTRY LEASE REFUSED

No. 214; Pioneer Concrete (Vic.) Pty. Ltd.; 7.6 ha, Parish of Boroka.

EXTRACTIVE INDUSTRY LEASE EXPIRED

No. 214; Pioneer Concrete (Vic.) Pty. Ltd.; 7.6 ha, Parish of Boroka.

ROBERT FORDHAM  
Minister for Industry, Technology and Resources

*Town and Country Planning Act 1961*

MELBOURNE METROPOLITAN PLANNING SCHEME

Notice that a Planning Scheme has been Prepared and is Available for Inspection

Amendment No. 381

Notice is hereby given that the Minister for Planning and Environment in pursuance of the powers under the *Town and Country Planning Act 1961* has prepared a planning scheme which—

(A) proposes to rezone land situated at—

1. South of Princes Highway and east of Hallam South Road, Hallam, Berwick.
2. Lot 1, McLeod Road, Carrum, Chelsea.
3. Generally fronting the east side of the Esplanade and Alfred Square, St. Kilda.
4. East and west sides of St. Kilda Road between Wellington Street and Carlisle Street, St. Kilda.
5. 500 Chapel Street, Prahran.
6. 7 Earl Street, Prahran.
7. Land bounded by Hampshire Road, Corio Street, Derby Road and right of way, Sunshine.
8. Lots 16 and 18 Princes Street, Glen Waverley.
9. Nos. 29, 38, 40 and 42, Challis Street, Newport, Williamstown.
10. Ferguson Street, Williamstown.

(B) proposes to amend the scheme Ordinance by—

1. Including Ordinance provisions relating to Rezoning (A) 3 above.
2. Including Ordinance provisions relating to rezoning (A) 4 above.
3. The inclusion of Lot 2, LP 139281, National Park Road, Kinglake West in the Table to Clause 11A (1) (c).
4. Amending the development parameters in the Table to Clause 22 (2) for the Gladstone Park Shopping Centre.
5. Amending the development parameters in Clause 22n for the Comprehensive Development Zone No. 4.
6. Minor amendments to Clauses 11B and 27.

A copy of the scheme will be deposited at the offices of the Ministry for Planning and Environment, The Olderfleet Buildings, 477 Collins Street, Melbourne, from 9 July 1986 to 11 August 1986.

A copy of the scheme Ordinance and so much of the scheme map which affects land within the area administered by the regional office of the Ministry or within the municipal district has been deposited at City Offices, City of Berwick, Princes Highway, Narre Warren; Municipal Offices, City of Chelsea, 312 Station Street, Chelsea; Town Hall, City of Hawthorn, 360 Burwood Road, Hawthorn; Town Hall, City of Prahran, Greville Street, Prahran; Town Hall, City of St. Kilda, Brighton Road, St. Kilda; Municipal Offices, City of Sunshine, Alexandra Avenue, Sunshine; Municipal Offices, City of Waverley, Springvale Road, Glen Waverley; Municipal Offices, City of Williamstown, 104 Ferguson Street, Williamstown.

A copy of the scheme Ordinance only has been deposited at Civic Offices, City of Altona, 115 Civic Parade, Altona; Town Hall, City of Box Hill, 1022 Whitehorse Road, Box Hill; Town Hall, City of Brighton, Boxshall Street, Brighton; Municipal Offices, City of Broadmeadows, Pascoe Vale Road, Broadmeadows; Municipal Offices, City of Brunswick, 233 Sydney Road, Brunswick; Civic Centre, City of Camberwell, 350 Camberwell Road, Camberwell; City Offices, City of Caulfield, cnr Hawthorn and Glen Eira Roads, Caulfield; City Offices, City of Coburg, Bell Street, Coburg; Municipal Offices, City of Collingwood, 140 Hoddle Street, Abbotsford; City Offices, City of Croydon, Civic Square, Croydon; Municipal Offices, City of Dandenong, 205 Thomas Street, Dandenong; Municipal Offices, City of Doncaster and Templestowe, 695 Doncaster Road, Doncaster; Civic Centre, City of Essendon, Pascoe Vale Road, Essendon; Municipal Offices, City of Fitzroy, 201 Napier Street, Fitzroy; Town Hall, City of Footscray, Napier Street, Footscray; Civic Centre, City of Frankston, Davey Street, Frankston; Civic Centre,

City of Heidelberg, Upper Heidelberg Road, Ivanhoe; Municipal Offices, City of Keilor, Calder Highway, Keilor; Municipal Offices, City of Kew, Charles Street, Kew; Civic Centre, City of Knox, 511 Burwood Highway, Knoxfield; Civic Centre, City of Malvern, cnr Glenferrie Road and High Street, Malvern; Town Hall, City of Melbourne, Council House, 200 Little Collins Street, Melbourne; Municipal Offices, City of Moorabbin, 977 Nepean Highway, Moorabbin; Council Chambers, City of Mordialloc, Mentone Parade, Mentone; Municipal Offices, City of Northcote, 189 High Street, Northcote; Civic Centre, City of Nunawading, 379 Whitehorse Road, Nunawading; Municipal Offices, City of Oakleigh, Atherton Road, Oakleigh; Town Hall, City of Port Melbourne, Bay Street, Port Melbourne; City Hall, City of Preston, High Street, Preston; Town Hall, City of Richmond, Bridge Road, Richmond; Civic Centre, City of Ringwood, Maroondah Highway, Ringwood; Municipal Offices, City of Sandringham, Royal Avenue, Sandringham; Town Hall, City of South Melbourne, Bank Street, South Melbourne; Civic Centre, City of Springvale, 397 Springvale Road, Springvale; Municipal Offices, Shire of Bulla, Macedon Street, Sunbury; Shire Offices, Shire of Cranbourne, Sladen Street, Cranbourne; Civic Centre, Shire of Diamond Valley, Civic Drive, Greensborough; Shire Offices, Shire of Eltham, 895 Main Road, Eltham; Shire Offices, Shire of Melton, cnr High and Yuille Streets, Melton; Civic Centre, Shire of Werribee, 45 Princes Highway, Werribee; Municipal Offices, Shire of Whittlesea, High Street, Epping; Municipal Offices, Shire of Pakenham, Henty Way, Pakenham.

A copy of the scheme or the relevant part thereof referred to above will be open for inspection during office hours by any person, free of charge.

Any persons affected by the scheme are required to set forth in writing, any submissions they wish to make with respect to the scheme, addressed to the Secretary, Ministry for Planning and Environment, P.O. Box 2240T, Melbourne 3001, by 11 August 1986, and state whether they wish to be heard in respect of their submission.

Dated 8 July 1986

DAVID YENCKEN

Secretary for Planning and Environment

*Building Control Act 1981*

**ORDER TO PROHIBIT THE OCCUPATION  
OR USE OF A BUILDING—CUMBERLAND  
HOTEL—279 LYTTLETON TERRACE,  
BENDIGO**

Whereas it is provided by section 143 of the *Building Control Act 1981* that where any works which are required to be carried out pursuant to the provisions of Part VIII of the *Building Control Act 1981* have not been carried out within the time allowed pursuant to this Part the Minister may by order under his hand published in the *Government Gazette* prohibit the occupation or use of the

building by any person and may at any time on the recommendation of the Chief Officer and the Building Surveyor by order under his hand published in the *Government Gazette* vary or revoke such Order.

And whereas the Chief Officer and the Building Surveyor have reported to the Minister the works required to be carried out within the time allowed with respect to the building known as the Cumberland Hotel—279 Lyttleton Terrace, Bendigo.

Now therefore I James Harley Kennan Her Majesty's Minister for Planning and Environment for the State of Victoria do by this Order prohibit the occupation or use of the Residential Accommodation Section of the above premises by any person other than the immediate family of the Licensee as and from 9 July 1986.

JAMES HARLEY KENNAN  
Minister for Planning and Environment  
Melbourne (86/7417)

*Building Control Act 1981*

ORDER TO PROHIBIT THE OCCUPATION  
OR USE OF A BUILDING—LAKE VIEW  
HOTEL—204 McRAE STREET, BENDIGO

Whereas it is provided by section 143 of the *Building Control Act 1981* that where any works which are required to be carried out pursuant to the provisions of Part VIII of the *Building Control Act 1981* have not been carried out within the time allowed pursuant to this Part the Minister may by order under his hand published in the *Government Gazette* prohibit the occupation or use of the building by any person and may at any time on the recommendation of the Chief Officer and the Building Surveyor by order under his hand published in the *Government Gazette* vary or revoke such Order.

And whereas the Chief Officer and the Building Surveyor have reported to the Minister the works required to be carried out pursuant to Part VIII of the Act have not been carried out within the time allowed with respect to the building known as the Lake View Hotel—204 McRae Street, Bendigo.

Now therefore I James Harley Kennan Her Majesty's Minister for Planning and Environment for the State of Victoria do by this Order prohibit the occupation or use of the Residential Accommodation Section of the above premises by any person other than the immediate family of the Licensee as and from 9 July 1986.

JAMES HARLEY KENNAN  
Minister for Planning and Environment  
Melbourne (86/7420)

*Town and Country Planning Act 1961*  
MELBOURNE METROPOLITAN PLANNING  
SCHEME

Notice of Execution of Instrument of Delegation  
and Revocation

Notice is hereby given that the Minister for Planning and Environment has in respect of the Melbourne Metropolitan Planning Scheme executed an instrument of delegation and revocation in favour of the Shire of Diamond Valley whereby such powers authorities and responsibilities conferred or imposed (as the case may be) under the Town and Country Planning Act or the said Planning Scheme are delegated to the Shire of Diamond Valley subject to the terms and conditions and the exclusions as are set out in such instrument, and that in such instrument it is provided that such delegation and revocation shall have force and effect from the date of publication of this Notice.

Copies of the Instruments of Delegation and Revocation may be inspected during office hours at the office of the Ministry for Planning and Environment, The Olderfleet Buildings, 477 Collins Street, Melbourne, and at the office of the Council of the Shire of Diamond Valley at Greensborough.

DAVID YENCKEN  
Secretary for Planning and Environment

FORFEITURE OF CROWN LEASE AT 10-18  
JACKA BOULEVARD, ST KILDA

To the lessee (Seaquarium Pty. Ltd.) and all other persons interested in Crown lease registered in the Office of Titles under Volume 1204 Folio 707 and being a lease of part of Allotment 102 St Kilda in the Parish of Melbourne South, County of Bourke.

Take Notice that—

1. The said Crown Lease is alleged by the Governor in Council as Lessor and by the Minister for Conservation, Forests and Lands to be liable to forfeiture for breaches of the Lessee's covenants and conditions therein.

2. For the purpose of allowing the Lessee and all other persons interested in the Lease to show cause to the Minister for Conservation, Forests and Lands against such forfeiture a Local Land Board appointed by the Minister for Conservation, Forests and Lands will publicly hear reasons against the forfeiture of the said Lease at 10.00 a.m. on Monday, 4 August 1986 at Linden Court, 26 Acland Street, St Kilda in the State of Victoria.

3. Particulars of the said breaches of covenants and conditions of the said Lease may be obtained during business hours at the office of the Crown Solicitor, 9th floor, 221 Queen Street, Melbourne, and by arrangement with Ms Para Andropoulos (phone 603 6859).

Dated 9 July 1986

J. E. KIRNER  
Minister for Conservation, Forests and Lands

Notice is hereby given that the State Electricity Commission of Victoria has applied for a Lease pursuant to section 134 *Land Act* 1958 for a term of 50 years in respect of Allotment 3 Section 59 Parish of Melbourne South City of Port Melbourne for State Electricity Commission Purposes (sub-station).

**VERMIN AND NOXIOUS WEEDS  
DESTRUCTION BOARD**

Pursuant to section 4 of the *Vermin and Noxious Weeds Act* 1958, Ernest L. Cattach, Administrative Officer Class "ADM 7", is assigned the duties of Secretary, Vermin and Noxious Weeds Destruction Board, without additional salary, as from 9 July 1986, vice James B. Kent (transferred).

**H. BUCKNALL**  
Director, Human Resource Management  
Department of Conservation, Forests and Lands

**CITY OF MELBOURNE  
Discontinuance of Roads**

Take notice that in accordance with the provisions of section 528 (2) (a) of the *Local Government Act* 1958, the Council of the City of Melbourne on 16 June 1986 resolved as follows:

- (a) That the portion of the private lane located at rear of Nos. 247-253 Drummond Street, Carlton, being land known as Naughton Place, as shown hatched on the plan hereunder, is not required for Public use; and
- (b) that the said portion of the road be discontinued and upon publication of the resolution in the *Government Gazette* the said road portion shall be deemed to be discontinued and the land being the said road portion shall vest in the municipality and may be sold by agreement.

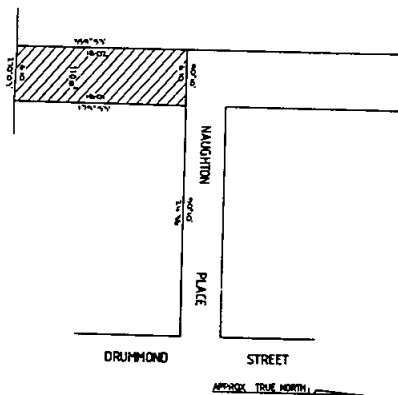

**3532 D. B. BETHKE**  
Chief Executive Officer and Town Clerk

**CITY OF MELBOURNE  
Discontinuance of Roads**

Take notice that in accordance with the provisions of section 528 (2) (a) of the *Local Government Act* 1958, the Council of the City of Melbourne on 16 June 1986 resolved as follows:

- (a) That the portion of the private lanes located off the eastern side of Eagle Alley and the western side of Park Street, Melbourne, as shown hatched on the plan hereunder, is not required for public use; and
- (b) that the said portion of the road be discontinued and upon publication of the resolution in the *Government Gazette* the said road portion shall be deemed to be discontinued and the land being the said road portion shall vest in the municipality and may be sold by agreement.

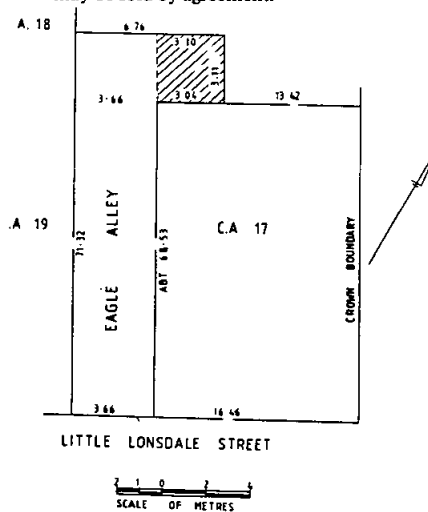

**D. N. BETHKE**  
3533 Chief Executive Officer and Town Clerk

Form 2. 1  
*Town and Country Planning Act* 1961  
**CITY OF ECHUCA PLANNING SCHEME 1981**  
Notice that a Planning Scheme has been Prepared  
and is Available for Inspection  
Amendment No. 3

Notice is hereby given that the City of Echuca in pursuance of its powers under the *Town and Country Planning Act* 1961 has prepared a scheme for the purpose of rezoning allotments 8, 9 and 10, section 23, Parish of Echuca North, fronting Hare, Darling and Nish Streets, Echuca from Public Purpose Reserve-Education Department and Commercial

"A", to special uses—Garden Car Park. A copy of the scheme has been deposited at the City Offices, cnr. Hare and Heygarth Streets, Echuca and at the Office of the Ministry for Planning and Environment, 391 Hargreaves Street, Bendigo and at the office of the Ministry for Planning and Environment (Plan Inspection Section), Ground Floor, The Olderfleet Buildings, 477 Collins Street, Melbourne, and will be open for inspection during office hours by any person free of charge.

Any persons affected by the scheme are required to set forth in writing any submission they may wish to make with respect to the scheme addressed to Town Clerk, City of Echuca, cnr. Hare and Heygarth Streets, Echuca, by 9 October 1986 and state whether they wish to be heard in respect of their submission

K. F. McCARTNEY  
Chief Executive Officer

3534

Local Government Act  
CITY OF GEELONG WEST  
Road Discontinuance Resolution

Whereas the Council of the City of Geelong West has done all those things required by section 528 (2) of the above Act to be done prior to the making of this Resolution and has formed the opinion that the road hereinafter mentioned is not reasonably required as a road for public use.

Now the said Council of the City of Geelong West pursuant to the power given to it by section 528 (2) of the said Act hereby resolves and directs—

- (a) that an unnamed Road running off the southern side of O'Connell Street, Geelong West which road is shown hatched on the plan hereunder, shall be discontinued;
- (b) that the land in the said road shall vest in the municipality to be retained by it for off-street car parking purposes.

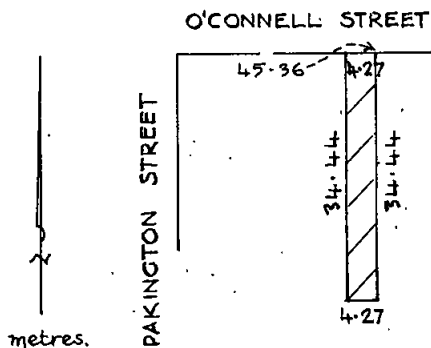

In witness whereof the common seal of the Mayor Councillors and Citizens of the City of Geelong West was affixed hereto 25 June 1986 in the presence of:

K. S. WILKS, Mayor  
AARON JOHN PANOZZO, Councillor  
R. J. HAMMETT, Town Clerk  
3556

Notice is hereby given that Raymond Keith Newlands, of Flat 9, 41 Alma Road, St. Kilda and Joseph Zalatan and Micheline Zalatan, both of 7 Vale Street, Belgrave Heights, formerly trading as a partnership together under the name "Silver Screens Video" at Shop 407A Waverley Gardens Shopping Centre, cnr Police and Jackson roads, Mulgrave and at Shop 112 Parkmore-Keysborough Shopping Centre, Keysborough, determined and dissolved the said partnership on 16 December 1985. 3461

**NOTICE OF MAKING OF  
STATUTORY RULES  
WHICH ARE NOT YET  
AVAILABLE**

Notice is given of the making of the following Statutory Rules:

- | No.      | Statutory Rule                                                                                                                  |
|----------|---------------------------------------------------------------------------------------------------------------------------------|
|          | <i>Dental Technicians Act 1972</i>                                                                                              |
| 145/1986 | Advanced Dental Technicians (Fees) Regulations 1986                                                                             |
|          | <i>Melbourne Metropolitan Board of Works Act 1958</i>                                                                           |
| 147/1986 | Special By-Law No. 30: Fees for Water Supply and Sewerage Services to Non-Rateable Property and Cultural and Recreational Lands |
|          | <i>Companies (Application of Laws) Act 1981</i>                                                                                 |
| 157/1986 | Companies (Application of Laws) (Further Amendment) Regulations 1986                                                            |
|          | <i>Securities Industry (Application of Laws) Act 1981</i>                                                                       |
| 160/1986 | Securities Industry (Application of Laws) (Amendment) Regulations 1986                                                          |
|          | <i>Cluster Titles Act 1974</i>                                                                                                  |
| 163/1986 | Cluster Titles (Register's Fees) Regulations 1986                                                                               |
|          | <i>Property Law Act 1958</i>                                                                                                    |
| 167/1986 | Property Law (Fees) Regulations 1986                                                                                            |



	No.		Price
<i>Instruments Act 1958</i>		<i>National Gallery of Victoria Act 1966</i>	
169/1986 Instruments (Fees) Regulations 1986	150/1986	National Gallery of Victoria (Admission Charges Amendment) Regulations 1986	
<i>Lotteries Gaming and Betting Act 1966</i>	7 July 1986		40c
173/1986 Lotteries Gaming and Betting (Raffles and Bingo Permits) (Amendment) Regulations 1986		<i>Magistrates' Court Act 1971</i>	
<i>Marine Act 1958</i>	151/1986	Magistrates' Courts (Costs) Rules 1986	
174/1986 Port Phillip Pilot Sack and Superannuation Fund Regulations	7 July 1986		90c
<i>Metropolitan Fire Brigades Superannuation Act 1976</i>	152/1986	Religious Successory and Charities Trusts (Fees) Rules 1986	
175/1986 Metropolitan Fire Brigades Superannuation (Board Scheme) (Amendment) Regulations 1986	7 July 1986		40c
<i>Superannuation Benefits Act 1977</i>	153/1986	Printers and Newspapers (Fees) Regulations 1986	
176/1986 Superannuation Benefits (Early Retirement) Regulations 1986	7 July 1986		40c
<i>Water and Sewerage Authorities (Restructuring) Act 1983</i>	154/1986	Legal Aid Commission (Legal Aid Review Committees Allowances) Regulations 1986	
177/1986 Water and Sewerage Authorities (Annual Reporting) Regulations 1986	7 July 1986		40c
<i>Decentralized Industry Incentive Payments Act 1972</i>	155/1986	Companies (Acquisition of Shares) (Application of Laws) Act 1981	
178/1986 Decentralized Industry Incentive Payments Regulations 1986	7 July 1986	Companies (Acquisition of Shares) (Application of Laws) (Amendment) Regulations 1986	40c
		<i>Companies (Application of Laws) Act 1981</i>	
	156/1986	Companies (Application of Laws) (Amendment) Regulations 1986	
	7 July 1986		40c
		<i>Companies (Application of Laws) Act 1981</i>	
	158/1986	Companies (Application of Laws) (Amendment No. 2) Regulations 1986	
	7 July 1986		40c

**NOTICE OF MAKING  
AND AVAILABILITY OF  
STATUTORY RULES**

In pursuance of the provisions of the *Subordinate Legislation Act 1962* and the Regulations made thereunder notice is given of the making and availability of the following Statutory Rules:

Note: The date specified after each Statutory Rule is the date it was first obtainable from the Victorian Government Bookshop, 41 St Andrew's Place, East Melbourne.

	<i>Companies (Acquisition of Shares) (Application of Laws) Act 1981</i>		<i>Transfer of Land Act 1958</i>	
159/1986	Companies (Acquisition of Shares) (Application of Laws) (Further Amendment) Regulations 1986	7 July 1986	166/1986 Transfer of Land (Fees) Regulations 1986	70c
7 July 1986		40c	<i>Strata Titles Act 1967</i>	
	<i>National Parks Act 1975</i>		168/1986 Strata Titles (Registrar's Fees) Regulations 1986	40c
161/1986	Park (Amendment) Regulations 1986	7 July 1986		
7 July 1986		40c	<i>Pay-roll Tax Act 1971</i>	
	<i>Health Act 1958</i>		170/1986 Pay-roll Tax (Further Amendment) Regulations 1986	40c
162/1986	Health (Blood Donors Prescribed Form) Regulations 1986	7 July 1986		
7 July 1986		40c	<i>Superannuation Benefits Act 1977</i>	
	<i>Public Service Act 1974</i>		171/1986 Superannuation Benefits Regulations (No. 2) 1986	40c
164/1986	Public Service (Amendment) Regulations (No. 4) 1986	7 July 1986		
7 July 1986		40c	<i>Supreme Court Act 1958</i>	
	<i>The Constitution Act Amendment Act 1958</i>		172/1986 Supreme Court (Monetary Penalty Instalment) Rules 1986	70c
165/1986	Electoral Rolls (Amending) Regulations 1986	7 July 1986		
7 July 1986		40c		

### Publication Details

The *Victoria Government Gazette* is published every Wednesday, unless otherwise advertised.

#### Copy Deadline

Private advertisements will be accepted by: Gazette Advertising  
Victorian Government Printing Office  
PO Box 203 North Melbourne 3051, no later than 11 a.m. on the day before publication.

#### Advertising Rates

Single column × cm/part cm ..... \$3.60  
Double column × cm/part cm ..... \$7.20  
Full page ..... \$151.00

Ordinary rates will apply to material submitted for publication before 11 a.m. Tuesday.

Double rates will apply for material submitted between 11 a.m. and 3.30 p.m. Tuesday.

#### Advertisers should note:

- There are approximately 30 words to each column centimetre depth;
- Signatures (in particular) and proper names must be written clearly in the text;
- Advertising material should be double-spaced and confined to ONE SIDE ONLY of each sheet of paper
- Documents NOT CLEARLY PREPARED will be returned to the sender, unpublished.

#### Correspondence

All correspondence should be addressed to:  
Gazette Advertising  
Victorian Government Printing Office  
PO Box 203 North Melbourne 3051  
Telephone Inquiries (03) 320 0100

### Publications Availability

Publications may be purchased from the  
**Victorian Government Bookshop**  
 41 St Andrews Place East Melbourne  
 (PO Box 203 North Melbourne 3051)  
 Telephone Inquiries (03) 320 0299

#### Mail Orders and Postage

A postage and packaging fee must be added to the cost of the requested publication using the table of rates below. Remittances should be made payable to the 'Victorian Government Printing Office'.

#### Bankcard

Purchases may be made using Bankcard facilities in the Bookshop and by mail order. Bankcard mail orders require the Bankcard number, expiry date, name, address and signature of customer to be supplied. (Minimum purchase of \$5.00 applies).

Total Price of Publications	Postage Packaging Fee
\$ 0.00 to \$ 2.00 .. ..	\$ 0.80
\$ 2.05 to \$ 5.00 .. ..	\$ 1.10
\$ 5.05 to \$ 25.00 .. ..	\$ 2.50
\$ 25.05 to \$ 75.00 .. ..	\$ 3.00
\$ 75.05 to \$125.00 .. ..	\$ 3.50
\$125.05 to \$200.00 .. ..	\$ 4.00
\$200.05 and over .. ..	at cost

### General Information

The following guidelines should be followed for the publication of official material in the *Victoria Government Gazette*.

#### Publication of official material

- Duplicate copies should be submitted for the use of the Gazette Officer.
- Material submitted to the Executive Council for Gazettal will normally be published in the next week's issue.
- Where urgent gazettal is required, special arrangements should be made with the:  
 Gazette Officer  
 Department of the Premier and Cabinet  
 Government Branch  
 2nd Floor, 1 Treasury Place  
 Melbourne 3000  
 Telephone Inquiries (03) 651 5153

#### Publication of other material

- All other material authorized by a responsible officer should be forwarded to the Gazette Officer no later than 9.30 a.m. on Tuesday.
- Lengthy or complicated notices should be forwarded several days before publication.
- Proofs will be supplied only when requested or at the direction of the Gazette Officer. They should be returned quickly to avoid delay in publication.
- No additions or amendments to material for publication will be accepted by telephone.

#### Late Copy

Copy received after 3.30 p.m. on the day prior to publication at the Victorian Government Printing Office will be placed in the following issue of the *Victoria Government Gazette*, irrespective of any date/s mentioned in the copy.

<b>CONTENTS</b>
-----------------

	Page
Appointments	2639
Contracts	2637
Estates of Deceased Persons	2636
Government Notices	2622
Late Notices	2685
Melbourne and Metropolitan Board of Works	2632
Notice of Making of Statutory Rules	2690
Orders in Council—	
Acts—Geelong Waterworks and Sewerage; Racing; Mines; et seq	2639
Victorian Civil Ambulance Service; Marketing of Primary Products; Water; Local Government; Health; Crown Land (Reserves)	
Police Sale	2637
Private Advertisements	2651
Proclamations	2619
Public Holiday	2619
Tenders	2650