

VICTORIA GOVERNMENT

G A Z E T T E

No. G 22 Wednesday 10 June 1987  
By Authority F D Atkinson Government Printer Melbourne

GENERAL

GENERAL INFORMATION

The General edition of the *Victoria Government Gazette* is published on each Wednesday and provides information on tenders for the State Government as well as other matters of general interest such as public and private notices.

Special issues of the *Victoria Government Gazette* when published will be made available automatically to subscribers of the General edition.

NOTICES TO BE PUBLISHED

**GOVERNMENT NOTICES** The following guidelines should be followed to ensure publication of official material in the *Victoria Government Gazette*.

**Publication of official material**

- Duplicate copies should be submitted for the use of the Gazette officer.
- Material submitted to the Executive Council for gazettal will normally be published in the following week's issue.
- Where urgent gazettal is required, special arrangements should be made with  
Mr Gerd Gaspar  
Gazette Officer  
Department of the Premier and Cabinet  
Government Branch  
2nd Floor, 1 Treasury Place  
Melbourne, 3002  
Telephone Inquiries  
(03) 651 5153

**Publication of other material**

- All other material authorised by a responsible officer should be forwarded to the Gazette Office no later than 9.30 am on Tuesday.
- Lengthy or complicated notices should be forwarded several days before publication.

- Proofs will be supplied only when requested or at the direction of Gazette Officer. They should be returned quickly to avoid delay in publication.
- No additions or amendments to material for publication will be accepted by telephone.

PRIVATE NOTICES

**Copy Deadline.** Private advertisements will be accepted by:

Gazette Advertising  
VGPO  
PO Box 203  
North Melbourne Vic 3051

no later than 11 am one day before publication.

**Advertising Rates**

Single column × cm/part cm .....\$3.85  
Double column × cm/part cm .....\$7.70  
Full page.....\$161.70

Ordinary rates will apply to material submitted for publication before 11 am Tuesday. Double rates will apply for special gazettes and for material submitted between 11 am and 3.30 pm Tuesday.

**Advertisers should note:**

- There are approximately 30 words to each column centimetre depth;
- Signatures (in particular) and proper names must be written clearly in the text;
- All material submitted for publication should be double-spaced and confined to ONE SIDE ONLY of each sheet of paper
- Documents NOT CLEARLY PREPARED will be returned to the sender, unpublished.

**Late Copy**

Copy received after 3.30 pm one day prior to publication at the VGPO will be placed in the following issue of the *Victoria Government Gazette*, irrespective of any date/s mentioned in the copy.

## CORRESPONDENCE

All correspondence should be addressed to:  
 Gazette Advertising  
 VGPO  
 PO Box 203  
 North Melbourne 3051  
 Telephone Inquiries (03) 320 0100  
 Fax No. (03) 329 2696

## AVAILABILITY

All gazettes may be purchased over the counter from VGPO Bookshop Information Victoria Centre  
 318 Lt Bourke Street, Melbourne. Telephone (03) 663 3760.  
 Cost for individual copies is \$1.10.

Mail orders may be sent to VGPO PO Box 203 North Melbourne 3051. A postage and packaging fee must be added to the cost of the gazettes required using the table of rates below:

Total Price of Publications	Postage Packaging Fee
\$0.00 to \$2.00 .....	\$0.80
\$2.05 to \$5.00 .....	\$1.10
\$5.05 to \$25.00 .....	\$2.50
\$25.05 to \$75.00 .....	\$3.00
\$75.05 to \$125.00 .....	\$3.50
\$125.00 to \$200.00 .....	\$4.00
\$200.05 and over .....	at cost

Bankcard purchases may be made using Bankcard facilities in the VGPO Bookshop and by mail orders.

Bankcard mail orders require the Bankcard number, expiry date, name, address and signature of customer to be supplied.

(Minimum purchase of \$5.00 applies).

## SUBSCRIPTIONS

Subscribers to the *Victoria Government Gazette* have three subscription services to choose from:  
 General Special and Periodical;  
 General and Special;  
 Periodical.

Subscriptions are payable in advance and accepted for a period of one year. All subscriptions are on a firm basis and refunds for cancellations will not be given.

Subscription rates for 1987 are as follows:

General Special and Periodical	\$115
General and Special	\$100
Periodical	\$60

Prices include postage.

All remittances should be made payable to VGPO.

## OTHER ISSUES OF THE GAZETTE

Special issues of the Gazette are published on specific days when required.

They are provided at no extra charge with weekly general issues.

Special issues are not available on separate subscription.

Periodical issues of the Gazette are published on each Monday when required. Listings such as Dentist's Register, Pharmacy Register are examples.

Subscription may be made separately at a cost of \$60.00 per annum including postage.

**PROCLAMATIONS**

*Land Act 1958*

**PROCLAMATION OF ROAD**

I, J. Davis McCaughey, Governor of Victoria, acting with the advice of the Executive Council and under section 25 (3) (c) of the *Land Act 1958* proclaim as road the following land:

**MUNICIPAL DISTRICT OF THE SHIRE OF GRENVILLE**

SCARSDALE—The land in the Parish of Scarsdale shown as Allotment 6, section 31 on Certified Plan No. 108402 lodged in the Central Plan Office—(Rs. 12898).

Given under my hand and the seal of Victoria on 2 June 1987.

(L.S.) J. DAVIS McCAUGHEY  
By His Excellency's Command

J. E. KIRNER  
Minister for Conservation, Forests and Lands

*Land Act 1958*

**PROCLAMATION OF ROADS**

I, J. Davis McCaughey, Governor of Victoria, acting with the advice of the Executive Council and under section 25 (3) (c) of the *Land Act 1958* proclaim as roads the following lands:

**MUNICIPAL DISTRICT OF THE SHIRE OF SWAN HILL**

TYNTYNDER—The land being Allotment 51A, Parish of Tyntynder as shown on Certified Plan No. 108365 lodged in the Central Plan Office—(L5-1538).

**MUNICIPAL DISTRICT OF THE SHIRE OF WALPEUP**

PIRRO—The land being Allotment 78c, Parish of Pirro as shown on Certified Plan No. 108370 lodged in the Central Plan Office—(Rs. 12633).

Given under my hand and the seal of Victoria on 2 June 1987.

(L.S.) J. DAVIS McCAUGHEY  
By His Excellency's Command

J. E. KIRNER  
Minister for Conservation, Forests and Lands

*Land Act 1958*

**PROCLAMATION OF ROAD**

I, J. Davis McCaughey, Governor of Victoria, acting with the advice of the Executive Council and under section 25 (3) (c) of the *Land Act 1958* proclaim as road the following land:

**MUNICIPAL DISTRICT OF THE CITY OF PORTLAND**

PORTLAND—The land in section 44 of the Township and Parish of Portland indicated by hatching on the plan hereunder—(P69 (7)) (L2-731).

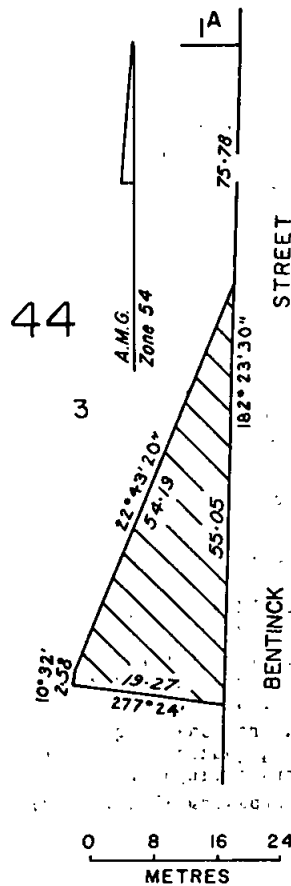

Given under my hand and the seal of Victoria on 2 June 1987.

(L.S.) J. DAVIS McCAUGHEY  
By His Excellency's Command

J. E. KIRNER  
Minister for Conservation, Forests and Lands

*Country Fire Authority Act 1958*  
PROCLAMATION

I, J. Davis McCaughey the Governor of the State of Victoria, by and with the advice of the Executive Council, under the powers conferred by section 15 of the *Country Fire Authority Act 1958* and after consideration of a report by the Country Fire Authority, proclaim the area of the Fourteenth Fire Control Region to be varied as follows:

In the Fourteenth Fire Control Region:  
*Woodend Urban Fire District*

Commencing at the south western corner of the boundary of the Shire of Newham and Woodend, thence generally northerly to Falloons Road to Tylden Road, thence easterly to the Campaspe River, thence generally northerly to Cemetery Road, thence easterly to Mowbrays Road, thence northerly to Garth Road, thence easterly to Boundary Road, thence southerly to the Five Mile Creek, thence easterly by the Five Mile Creek to its intersection with Coach Road, thence southerly by Coach Road to the Woodend-Wallen Road, thence south westerly to Lavender Farm Road, thence generally south easterly to the intersection of the Mount Macedon Road, thence generally easterly and westerly to Cameron Drive, thence south westerly by Cameron Drive to its intersection with the boundary of the Shire of Newham and Woodend, thence generally southerly and westerly to the point of commencement.

Given under my hand and the seal of Victoria on 2 June 1987.

(L.S.) J. DAVIS McCaughey  
By His Excellency's Command

C. R. T. MATHEWS  
Minister for Police and Emergency Services

*Post-Secondary Education Amendment Act*  
1987

PROCLAMATION OF COMMENCEMENT

I, J. Davis McCaughey, Governor of Victoria acting on the advice of the Executive Council and under section 2 of the *Post-Secondary Education (Amendment) Act 1987*, fix Wednesday, 1 July 1987 as the day on which that Act comes into operation.

Given under my hand and the seal of Victoria on 2 June 1987.

(L.S.) J. DAVIS McCaughey  
By His Excellency's Command

I. R. CATHIE  
Minister for Education

*Local Government (General Amendment) Act*  
1986, Act No. 108/1986

PROCLAMATION OF COMMENCEMENT

I, J. Davis McCaughey, Governor of Victoria, acting with the advice of the Executive Council and under section 2 of the *Local Government (General Amendment) Act 1986*, fix 15 June 1987 as the day on which sections 11, 14, 18, 19, 20, 26, 27, 31, 42, 43 and 50 of that Act shall come into operation.

Given under my hand and the seal of Victoria on 10 June 1987.

(L.S.) J. DAVIS McCaughey  
By His Excellency's Command

J. L. SIMMONDS  
Minister for Local Government

*Local Government Act 1958*

PRESCRIBED RATE OF INTEREST ON  
RATES AND OTHER MONEYS

I, J. Davis McCaughey, Governor of Victoria, acting with the advice of the Executive Council and under section 386 of the *Local Government Act 1958* fix 17.25% as the rate of interest for the purposes of that section as amended by section 27 of the *Local Government (General Amendment) Act 1986*, to apply on and after 15 June 1987.

Given under my hand and the seal of Victoria on 10 June 1987.

(L.S.) J. DAVIS McCaughey  
By His Excellency's Command

J. L. SIMMONDS  
Minister for Local Government

**GOVERNMENT NOTICES**

*Town and Country Planning Act 1961*  
**MELBOURNE METROPOLITAN  
PLANNING SCHEME**  
Amendment No. 466  
Notice of Amendment

In pursuance of the powers conferred by the *Town and Country Planning Act 1961*, the Governor in Council on 2 June 1987, amended the abovementioned scheme in respect of the municipal district of the City of Hawthorn and for which the Minister for Planning and Environment is the Responsible Authority.

The amendment comes into operation on the date this notice is published in the *Government Gazette*.

The amendment includes an Ordinance amendment that makes Dual Occupancy an as of right use in the Urban Conservation-Residential Zone No. 1. Dual Occupancy is currently prohibited.

A copy of the documents may be inspected free of charge, during office hours, at the office of the Ministry for Planning and Environment, The Olderfleet Buildings, 477 Collins Street, Melbourne.

**DAVID YENCKEN**  
Secretary for Planning and Environment

*Town and Country Planning Act 1961*  
**MELBOURNE METROPOLITAN  
PLANNING SCHEME**  
Amendment No. 456  
Notice of Amendment

In pursuance of the powers conferred by the *Town and Country Planning Act 1961*, the Governor in Council on 2 June 1987, amended the abovementioned scheme in respect of the municipal districts of the Cities of Brighton and South Melbourne for which the Minister for Planning and Environment is the Responsible Authority.

The amendment comes into operation on the date this notice is published in the *Government Gazette*.

The amendment includes the rezoning of land:

- (1) on the south-west corner of Bay and Hampton Streets, Brighton from Proposed Road Widening to Residential C; and
- (2) on the south side of Brady Street between Johnstone and Gittus Streets, South Melbourne, from Proposed Road Widening to General Industrial.

A copy of the documents may be inspected free of charge, during office hours, at the office of the Ministry for Planning and Environment, The Olderfleet Buildings, 477 Collins Street, Melbourne.

**DAVID YENCKEN**  
Secretary for Planning and Environment

*Town and Country Planning Act 1961*  
**SHIRE OF LILLYDALE PLANNING  
SCHEME 1958**  
Amendment No. 237  
Notice of Amendment

In pursuance of the powers conferred by the *Town and Country Planning Act 1961*, the Governor in Council on 2 June 1987, amended the abovementioned scheme in respect of the municipal district of the Shire of Lillydale and for which the Lillydale Shire Council is the Responsible Authority.

The amendment comes into operation on the date this notice is published in the *Government Gazette*.

The amendment includes the rezoning of a 20 metre wide strip of disused aqueduct land between Priestly Crescent and Hazel Street, Mt Evelyn from Existing Public Purposes Reservation (MMBW) to Rural (Intensive Agriculture).

A copy of the documents may be inspected free of charge, during office hours, at the office of the Ministry for Planning and Environment, The Olderfleet Buildings, 477 Collins Street, Melbourne and at the office of the Council of the Shire of Lillydale at Lillydale.

**DAVID YENCKEN**  
Secretary for Planning and Environment

*Town and Country Planning Act 1961*  
**SHIRE OF FLINDERS PLANNING SCHEME**  
Amendment No. 221  
Notice of Amendment

In pursuance of the powers conferred by the *Town and Country Planning Act 1961*, the Governor in Council on 2 June 1987 amended the abovementioned scheme in respect of the municipal district of the Shire of Flinders and for which the Shire of Flinders is the Responsible Authority.

The amendment comes into operation on the date this notice is published in the *Government Gazette*.

The amendment rezones Lot 1, LP 122083, Stokes Street, Flinders from Public Purposes Reserve—Morrington Peninsula and District Water Board to Village Residential 2 Zone.

A copy of the documents may be inspected free of charge, during office hours, at the office of the Ministry for Planning and Environment, The Olderfleet Buildings, 477 Collins Street, Melbourne and at the office of the Shire of Flinders, Boneo Road, Rosebud.

DAVID YENCKEN  
Secretary for Planning and Environment

*Town and Country Planning Act 1961*  
MELBOURNE METROPOLITAN  
PLANNING SCHEME  
Amendment No. 383 Part 2  
Notice of Approval

In pursuance of the powers conferred by the *Town and Country Planning Act 1961*, the Governor in Council on 2 June 1987, approved the abovementioned scheme in respect of the municipal district of the City of Northcote and for which the Minister for Planning and Environment is the Responsible Authority.

The scheme comes into operation on the date this notice is published in the *Government Gazette*.

The scheme includes the rezoning of land on the east side of High Street, between Robbs Parade and Separation Street, Northcote, from part Light Industrial and part Extractive Industrial to Restricted Business, and an Ordinance amendment, to allow the extension of the existing Northcote Plaza Shopping Centre.

A copy of the documents may be inspected free of charge, during office hours, at the office of the Ministry for Planning and Environment, The Olderfleet Buildings, 477 Collins Street, Melbourne.

DAVID YENCKEN  
Secretary for Planning and Environment

*Town and Country Planning Act 1961*  
SHIRE OF FLINDERS PLANNING SCHEME  
Amendment No. 205  
Notice of Approval

In pursuance of the powers conferred by the *Town and Country Planning Act 1961*, the Governor in Council on 2 June 1987, approved the abovementioned scheme in respect of the municipal district of the Shire of Flinders and for which the Council of the Shire of Flinders is the Responsible Authority.

The scheme comes into operation on the date this notice is published in the *Government Gazette*.

The scheme introduces controls relating to advertising signs in connection with authorised uses on land.

A copy of the documents may be inspected free of charge, during office hours, at the office of the Ministry for Planning and Environment (Plan Inspection Section), The Olderfleet Buildings, 477 Collins Street, Melbourne and at the office of the Council of the Shire of Flinders, Boneo Road, Rosebud.

DAVID YENCKEN  
Secretary for Planning and Environment

*Town and Country Planning Act 1961*  
SHIRE OF FLINDERS PLANNING SCHEME  
Amendment No. 204  
Notice of Approval

In pursuance of the powers conferred by the *Town and Country Planning Act 1961*, the Governor in Council on 2 June 1987, approved the abovementioned scheme in respect of the municipal district of the Shire of Flinders and for which the Shire of Flinders is the Responsible Authority.

The scheme comes into operation on the date this notice is published in the *Government Gazette*.

The scheme rezones Lot 32, LP 19465, Lyons Street, Rye from Local Commercial Zone to Public Purpose Reserve—Carpark.

A copy of the documents may be inspected free of charge, during office hours, at the office of the Ministry for Planning and Environment (Plan Inspection Section), The Olderfleet Buildings, 477 Collins Street, Melbourne and at the office of the Council of the Shire of Flinders, Boneo Road, Rosebud.

DAVID YENCKEN  
Secretary for Planning and Environment

*Town and Country Planning Act 1961*  
SHIRE OF BULLA PLANNING SCHEME  
Amendment No. 106  
Notice of Approval

In pursuance of the powers conferred by the *Town and Country Planning Act 1961*, the Governor in Council on 2 June 1987, approved the abovementioned scheme in respect of the municipal district of the Shire of Bulla and for which the Shire of Bulla is the Responsible Authority.

The scheme comes into operation on the date this notice is published in the *Government Gazette*.

The scheme includes the rezoning of land at Lots 1-3, LP 69562, on the northern side of Reservoir Road, Sunbury, from Rural to Residential.

A copy of the documents may be inspected free of charge, during office hours, at the office of the Ministry for Planning and Environment, The Olderfleet Buildings, 477 Collins Street, Melbourne and at the office of the Shire of Bulla, Macedon Street, Sunbury.

DAVID YENCKEN  
Secretary for Planning and Environment

*Town and Country Planning Act 1961*  
CITY OF KNOX PLANNING SCHEME 1965  
Amendment No. 291, 1986  
Notice of Amendment

In pursuance of the powers conferred by the *Town and Country Planning Act 1961*, the Governor in Council on 2 June 1987 amended the abovementioned scheme in respect of the municipal district of the City of Knox and for which the Council of the City of Knox is the Responsible Authority.

The amendment comes into operation on the date this notice is published in the *Government Gazette*.

The amendment includes land at part Lot 1 LP 30819 eastern corner of Burwood Highway and Mountain Highway, Wantirna, in a Special Uses "D" Zone.

A copy of the documents may be inspected free of charge, during office hours at the offices of the Ministry for Planning and Environment, The Olderfleet Buildings, 477 Collins Street, Melbourne and at the office of the Responsible Authority, Knox Civic Centre, 511 Burwood Highway, Knoxfield.

DAVID YENCKEN  
Secretary for Planning and Environment

*Town and Country Planning Act 1961*  
CITY OF KNOX PLANNING SCHEME 1965  
Amendment No. 293, 1987  
Notice of Approval

In pursuance of the powers conferred by the *Town and Country Planning Act 1961*, the Governor in Council on 2 June 1987 approved the abovementioned scheme in respect of the municipal district of the City of Knox and for which the Council of the City of Knox is the Responsible Authority.

The scheme comes into operation on the date this notice is published in the *Government Gazette*.

The scheme includes land at part of Crown Allotment 10, section 11, Parish of Narree Worran, partly in an Industrial Buffer Zone, partly a Light Industrial Zone, partly a General Industrial Zone and partly a Stream Zone.

A copy of the documents may be inspected free of charge, during office hours at the office of the Ministry for Planning and Environment, The Olderfleet Buildings, 477 Collins Street, Melbourne and at the office of the Responsible Authority, Knox Civic Centre, 511 Burwood Highway, Knoxfield.

DAVID YENCKEN  
Secretary for Planning and Environment

*Town and Country Planning Act 1961*  
CITY OF BALLAARAT PLANNING  
SCHEME

Amendment No. 96  
Notice of Approval

In pursuance of the powers conferred by the *Town and Country Planning Act 1961*, the Governor in Council on 2 June 1987, approved the abovementioned scheme in respect of the municipal district of the City of Ballarat and for which the City of Ballarat is the Responsible Authority.

The scheme comes into operation on the date this notice is published in the *Government Gazette*.

The scheme includes inserting a new definition of 'Warehouse (Storage of Furniture)' into the Planning Scheme Ordinance and to make this a use requiring Council consent on land known as 11 Davey Street, Ballarat.

A copy of the documents may be inspected free of charge, during office hours, at the office of the Ministry for Planning and Environment, The Olderfleet Buildings, 477 Collins Street, Melbourne and at the office of the responsible authority City of Ballarat, Town Hall, Sturt Street, Ballarat.

DAVID YENCKEN  
Secretary for Planning and Environment

*Town and Country Planning Act 1961*  
CITY OF BALLAARAT PLANNING  
SCHEME

Amendment No. 93  
Notice of Approval

In pursuance of the powers conferred by the *Town and Country Planning Act 1961*, the Governor in Council on 2 June 1987, approved the abovementioned scheme in respect of the municipal district of the City of Ballarat and for which the City of Ballarat is the Responsible Authority.

The scheme comes into operation on the date this notice is published in the *Government Gazette*.

The scheme includes inserting a new definition of "Tourist Facility Restaurant" into the Planning Scheme Ordinance and to make the use subject to Council consent on a site specific basis.

A copy of the documents may be inspected free of charge, during office hours, at the office of the Ministry for Planning and Environment, The Olderfleet Buildings, 477 Collins Street, Melbourne and at the office of the responsible authority City of Ballarat, Town Hall, Sturt Street, Ballarat.

DAVID YENCKEN  
Secretary for Planning and Environment

*Town and Country Planning Act 1961*  
CITY OF MILDURA PLANNING SCHEME  
Amendment No. 73 (Part 1)

Notice of Approval

In pursuance of the powers conferred by the *Town and Country Planning Act 1961*, the Governor in Council on 2 June 1987, approved the abovementioned scheme in respect of the municipal district of the City of Mildura and for which the City of Mildura is the Responsible Authority.

The scheme comes into operation on the date this notice is published in the *Government Gazette*.

The scheme is an amendment to the Planning Scheme Ordinance to change "tourist establishment" from a prohibited use to a consent use in the Agricultural 'B' zone.

A copy of the documents may be inspected free of charge, during office hours, at the office of the Ministry for Planning and Environment, The Olderfleet Buildings, 477 Collins Street, Melbourne and at the office of the Responsible Authority, the City of Mildura, 76-84 Deakin Avenue, Mildura, 3500.

DAVID YENCKEN  
Secretary for Planning and Environment

*Town and Country Planning Act 1961*  
SHIRE OF HASTINGS PLANNING  
SCHEME

Amendment No. 30 Part B

Notice of Approval

In pursuance of the powers conferred by the *Town and Country Planning Act 1961*, the Governor in Council on 2 June 1987 approved the abovementioned scheme in respect of the municipal district of the Shire of Hastings and for which the Shire of Hastings is the Responsible Authority.

The scheme comes into operation on the date this notice is published in the *Government Gazette*.

The scheme rezones Lot 12, LP 82488 and Part Lot 2, LP 98738, Camp Hill Road, Somers to Recreation Reserve.

A copy of the documents may be inspected free of charge, during office hours, at the office of the Ministry for Planning and Environment, The Olderfleet Buildings, 477 Collins Street, Melbourne and at the office of the Shire of Hastings, Marine Parade, Hastings.

DAVID YENCKEN  
Secretary for Planning and Environment

*Town and Country Planning Act 1961*  
SHIRE OF HASTINGS PLANNING  
SCHEME

Amendment No. 30A Pt. 2

Notice of Approval

In pursuance of the powers conferred by the *Town and Country Planning Act 1961*, the Governor in Council on 2 June 1987 approved the abovementioned scheme in respect of the municipal district of the Shire of Hastings and for which the Shire is the Responsible Authority.

The scheme comes into operation on the date this notice is published in the *Government Gazette*.

The scheme includes land within the Old Tyabb Township in a Medium Density 3 zone and also includes 5 shop sites on the south-west corner of Disney Street and Stony Point Road, Crib Point, within a Local Shopping zone.

A copy of the documents may be inspected free of charge, during office hours, at the office of the Ministry for Planning and Environment (Plan Inspection Section), The Olderfleet Buildings, 477 Collins Street, Melbourne and at the office of the responsible authority, Shire of Hastings Council, Marine Parade, Hastings.

DAVID YENCKEN  
Secretary for Planning and Environment

*Town and Country Planning Act 1961*  
SHIRE OF HASTINGS PLANNING  
SCHEME

Amendment No. 32

Notice of Approval

In pursuance of the powers conferred by the *Town and Country Planning Act 1961*, the Governor in Council on 2 June 1987 approved the abovementioned scheme in respect of the municipal district of the Shire of Hastings and for which the Council of the Shire of Hastings is the Responsible Authority.



The scheme comes into operation on the date this notice is published in the *Government Gazette*.

The scheme involves 29 minor planning scheme map changes to recognise the current ownership and use of various properties in the municipality.

A copy of the documents may be inspected free of charge, during office hours, at the office of the Ministry for Planning and Environment (Plan Inspection Section), The Olderfleet Buildings, 477 Collins Street, Melbourne and at the office of the Shire of Hastings, Marine Parade, Hastings.

DAVID YENCKEN  
Secretary for Planning and Environment

*Town and Country Planning Act 1961*  
SHIRE OF TAMBO (BALANCE OF SHIRE)  
PLANNING SCHEME INTERIM  
DEVELOPMENT ORDER

Amendment No. 6  
Notice of Approval

In pursuance of the powers conferred by the *Town and Country Planning Act 1961*, the Governor in Council on 2 June 1987, approved the abovementioned scheme in respect of the municipal district of the Shire of Tambo and for which the Shire of Tambo is the Responsible Authority.

The scheme comes into operation on the date this notice is published in the *Government Gazette*.

The scheme enables Council to consider an application for a 2 lot subdivision of Part Crown Allotment 168, section A, Parish of Tambo, Engineers Road, Bruthen, with the minimum allotment area being 2 hectares.

A copy of the documents may be inspected free of charge, during office hours, at the office of the Ministry for Planning and Environment, The Olderfleet Buildings, 477 Collins Street, Melbourne and at the office of the Responsible Authority, Shire of Tambo, 51 Main Street, Bruthen.

DAVID YENCKEN  
Secretary for Planning and Environment

*Town and Country Planning Act 1961*  
SHIRE OF TAMBO (BALANCE OF SHIRE)  
PLANNING SCHEME INTERIM  
DEVELOPMENT ORDER

Amendment No. 10  
Notice of Approval

In pursuance of the powers conferred by the *Town and Country Planning Act 1961*, the

Governor in Council on 2 June 1987, approved the abovementioned scheme in respect of the municipal district of the Shire of Tambo and for which the Shire of Tambo is the Responsible Authority.

The scheme comes into operation on the date this notice is published in the *Government Gazette*.

The scheme enables Council to consider an application for a house on Consolidation Plan 160599, Broadlands Road, Metung, which is 1.8 metres higher than the 4.5 metres maximum height restriction for the area.

A copy of the documents may be inspected free of charge, during office hours, at the office of the Ministry for Planning and Environment, The Olderfleet Buildings, 477 Collins Street, Melbourne and at the office of the Responsible Authority, Shire of Tambo, 51 Main Street, Bruthen.

DAVID YENCKEN  
Secretary for Planning and Environment

*Town and Country Planning Act 1961*  
SHIRE OF BULLA PLANNING SCHEME  
Amendment No. 105  
Notice of Approval

In pursuance of the powers conferred by the *Town and Country Planning Act 1961*, the Governor in Council on 2 June 1987, approved the abovementioned scheme in respect of the municipal district of the Shire of Bulla and for which the Shire of Bulla is the Responsible Authority.

The scheme comes into operation on the date this notice is published in the *Government Gazette*.

The scheme includes land comprising part Crown Allotment 2, section 22 and part Crown Allotment 14, section A, Parish of Bulla Bulla, being lots having abuttal to Muirfield Drive, Hoylake Court, Carnoustie Drive, Winged Foot Court and Mere Court, being Stage 10 of the Goonawarra Estate, Sunbury.

A copy of the documents may be inspected free of charge, during office hours, at the office of the Ministry for Planning and Environment, The Olderfleet Buildings, 477 Collins Street, Melbourne and at the office of the responsible authority, Shire of Bulla, Macedon Street, Sunbury.

DAVID YENCKEN  
Secretary for Planning and Environment

1480 G 22 10 June 1987

Victoria Government Gazette

*Town and Country Planning Act 1961*  
**SHIRE OF BULLA PLANNING SCHEME**  
Amendment No. 108  
Notice of Approval

In pursuance of the powers conferred by the *Town and Country Planning Act 1961*, the Governor in Council on 2 June 1987, approved the abovementioned scheme in respect of the municipal district of the Shire of Bulla and for which the Shire of Bulla is the Responsible Authority.

The scheme comes into operation on the date this notice is published in the *Government Gazette*.

The scheme includes the rezoning of land comprising Crown Allotments 49, 52 and 57, Parish of Buttlejorck, north side of Gap Road, Sunbury, from Rural to Residential.

A copy of the documents may be inspected free of charge, during office hours, at the office of the Ministry for Planning and Environment, The Olderfleet Buildings, 477 Collins Street, Melbourne and at the office of the Shire of Bulla, Macedon Street, Sunbury.

DAVID YENCKEN  
Secretary for Planning and Environment

*Town and Country Planning Act 1961*  
**SHIRE OF UPPER YARRA**  
**INTERIM DEVELOPMENT ORDER**  
Amendment No. 133  
Notice of Amendment

In pursuance of the powers conferred by the *Town and Country Planning Act 1961*, the Governor in Council on 2 June 1987 amended the abovementioned Order in respect of Lot 2 Lodged Plan No. 99918 Healesville-Koo Wee Rup Road, Yellingbo and for which the Shire of Upper Yarra is the responsible Authority.

The amendment comes into operation on the date this notice is published in the *Government Gazette*.

The amendment includes a provision allowing the subdivision of the land into two lots.

A copy of the documents may be inspected free of charge, during office hours, at the offices of the Ministry for Planning and Environment, The Olderfleet Buildings, 477 Collins Street, Melbourne and at the office of the Council of the Shire of Upper Yarra.

DAVID YENCKEN  
Secretary for Planning and Environment

*Town and Country Planning Act 1961*  
**SHIRE OF MORNINGTON PLANNING SCHEME**  
Amendment No. 185  
Notice of Approval

In pursuance of the powers conferred by the *Town and Country Planning Act 1961*, the Governor in Council on 2 June 1987 approved the abovementioned scheme in respect of the municipal district of the Shire of Mornington and for which the Shire of Mornington is the Responsible Authority.

The scheme comes into operation on the date this notice is published in the *Government Gazette*.

The scheme rezones Lot 1, LP 61347, at the south west corner of Watson Road and Langrigg Avenue, Mt Martha from Public Purposes (Proposed) Municipal Parking Area Reservation to Local Shopping Zone.

A copy of the documents may be inspected free of charge, during office hours, at the office of the Ministry for Planning and Environment (Plan Inspection Section), The Olderfleet Buildings, 477 Collins Street, Melbourne and at the office of the Shire of Mornington, Queen Street, Mornington.

DAVID YENCKEN  
Secretary for Planning and Environment

*Town and Country Planning Act 1961*  
**SHIRE OF WOORAYL PLANNING SCHEME**  
Amendment No. 86  
Notice of Amendment

In pursuance of the powers conferred by the *Town and Country Planning Act 1961*, the Governor in Council on 2 June 1987 amended the abovementioned scheme in respect of the municipal district of the Shire of Woorayl and for which the Council of the Shire of Woorayl is the Responsible Authority.

The amendment comes into operation on the date this notice is published in the *Government Gazette*.

The amendment includes the deletion of a 5 metre proposed road widening reserve on both sides of Geale Street, Meeniyah and the imposition of the abutting zones over the land.

A copy of the documents may be inspected free of charge, during office hours, at the office of the Ministry for Planning and Environment, The Olderfleet Buildings, 477 Collins Street, Melbourne and at the office of the responsible authority, the Council of the Shire of Woorayl, 9 Smith Street, Leongatha.

DAVID YENCKEN  
Secretary for Planning and Environment

*Town and Country Planning Act 1961*  
SHIRE OF WOORAYL PLANNING  
SCHEME

Amendment No. 87  
Notice of Amendment

In pursuance of the powers conferred by the *Town and Country Planning Act 1961*, the Governor in Council on 2 June 1987 amended the abovementioned scheme in respect of the municipal district of the Shire of Woorayl and for which the Council of the Shire of Woorayl is the Responsible Authority.

The amendment comes into operation on the date this notice is published in the *Government Gazette*.

The amendment includes ordinance changes to extend the time of expiry for the 40 ha minimum rural lot size provision from 30 April 1987 to 30 April 1988.

A copy of the documents may be inspected free of charge, during office hours, at the office of the Ministry for Planning and Environment, The Olderfleet Buildings, 477 Collins Street, Melbourne and at the office of the responsible authority, the Council of the Shire of Woorayl, 9 Smith Street, Leongatha.

DAVID YENCKEN  
Secretary for Planning and Environment

*Town and Country Planning Act 1961*  
SHIRE OF SHERBROOKE PLANNING  
SCHEME 1979 (URBAN AREAS)

Amendment No. 41  
Notice of Approval

In pursuance of the powers conferred by the *Town and Country Planning Act 1961*, the Governor in Council on 2 June 1987, approved the abovementioned scheme in respect of the municipal district of the Shire of Sherbrooke and for which the Council of the Shire of Sherbrooke is the Responsible Authority.

The scheme comes into operation on the date this notice is published in the *Government Gazette*.

The scheme includes land at part of Lots 135 and 136 LP 6970 and part of Lot 121 LP 6548 Avonside Road, Belgrave Heights, in a Bushland Residential Zone.

A copy of the documents may be inspected free of charge, during office hours, at the offices of the Ministry for Planning and Environment, The Olderfleet Buildings, 477 Collins Street, Melbourne and at the office of the responsible authority, Shire Offices, Glenfern Road, Upwey.

DAVID YENCKEN  
Secretary for Planning and Environment

*Town and Country Planning Act 1961*  
GEELONG REGIONAL PLANNING  
SCHEME

Amendment No. 167, 1986  
Notice of Approval

In pursuance of the powers conferred by the *Town and Country Planning Act 1961*, the Governor in Council on 2 June 1987, approved the abovementioned scheme in respect of the municipal district of the Shire of Corio and for which the Geelong Regional Commission is the Responsible Authority.

The scheme comes into operation on the date this notice is published in the *Government Gazette*.

The scheme includes the rezoning of land in the Lara Shopping Centre to Residential A, District Business and Public Purposes (Existing): Local Government, to implement the Lara Structure Plan.

A copy of the documents may be inspected free of charge, during office hours, at the office of the Ministry for Planning and Environment, The Olderfleet Buildings, 477 Collins Street, Melbourne and at the office of the responsible authority, State Government Offices, corner Little Malop and Fenwick Streets, Geelong.

DAVID YENCKEN  
Secretary for Planning and Environment

*Transport Act 1983*  
ROAD TRANSPORT LICENSING  
TRIBUNAL

Commercial Passenger Vehicle Applications

Notice is hereby given that applications by the following parties, previously gazetted and objected to, will be considered by the Road Transport Licensing Tribunal in the Public Hearing Theatre at the offices of the Road Traffic Authority, corner Lygon and Princes Streets, Carlton on Friday, 10 July 1987, commencing at 9.30 a.m.

Applicant	Previous Gazette No.	Date
M. G. Carrison	G 16	29.4.87
R. W. Neale	G 14	8.4.87
A. J. Wisby	G 14	8.4.87

Dated 10 June 1987

G. S. HUGHES  
Registrar

Transport Act 1983

VARIATIONS OF DECLARATIONS AND DEDICATIONS OF ROADS

The Road Construction Authority, in pursuance of the powers conferred by the Transport Act 1983, varies the declarations of roads as described below, and further declares that any new roads, deviations or widenings made by the Authority and included in such variations are fit to be used as public highways—

State Highway

17/87—By including in the declaration of the Maroondah Highway in the City of Nunawading the land shown hatched on plan numbered GP 17208.

Main Roads

18/87—By including in the declaration of the Broadford-Wallan Road in the Shire of Broadford the land shown hatched on plan numbered GP 2235A and excluding from the said declaration the land shown cross hatched on the said plan.

19/87—By including in the declaration of the Geelong-Ballan Road in the Shire of Ballan the land shown hatched on plan numbered GP 16532A and excluding from the declaration the land shown cross hatched on the said plan.

Forest Road

20/87—By including in the declaration of the Carrajung-Woodside Road in the Shire of Alberton the land shown hatched on plan numbered GP 15530r and excluding from the declaration the land shown cross hatched on the said plan.

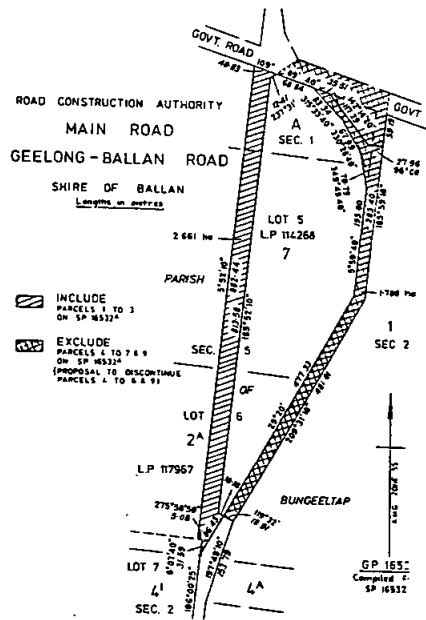
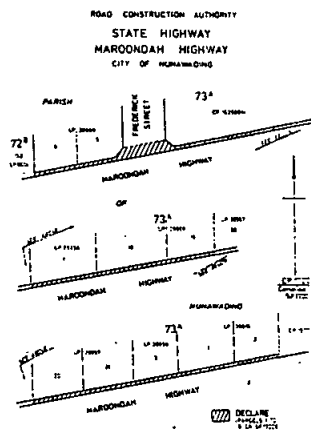
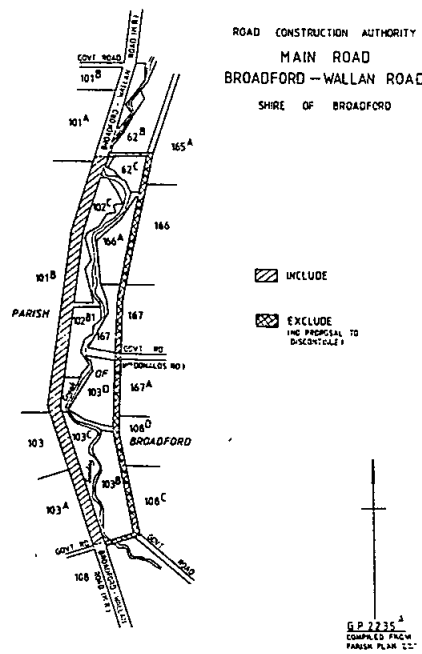

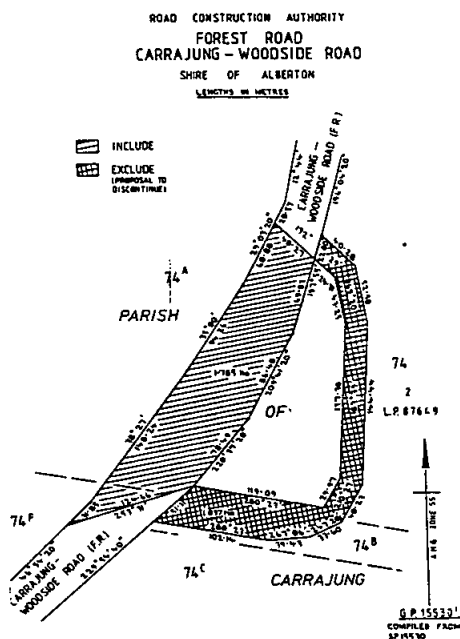

In accordance with the provisions of Clause 2 (2), Schedule 5 of the *Transport Act 1983*, the new roads, deviations or widenings made by the Authority shall, upon the publication of this notice in the *Government Gazette*, become and be absolutely dedicated to the public as a public highway within the meaning of any law now or hereafter in force.

Dated 14 May 1987

IAN F. X. STONEY, Managing Director  
Road Construction Authority

*Transport Act 1983*  
ROAD TRAFFIC AUTHORITY

Commercial Passenger Vehicle Applications

Notice is hereby given that the following applications will be considered by the Road Traffic Authority on 14 July 1987.

Notice of any objections should be forwarded to reach the Manager, Vehicle Licensing Branch or any Regional Office of the Road Traffic Authority not later than 8 July 1987.

It will not be necessary for interested parties to appear on the hearing date specified, unless advised in writing by the Authority.

Notification of the date for consideration of applications which are objected to and which

require determination by the Road Transport Licensing Tribunal will be published by further notice in this Gazette.

G. Campagnolo, Clifton Springs. Application to license three commercial passenger vehicles in respect of 3 Mercedes Benz sedans (1972, 1977, 1982) each with seating capacity for 4 passengers to operate as special purpose vehicles from 126 Bayshore Avenue, Clifton Springs for the carriage of passengers for wedding parties.

W. A. Gardiner Pty. Ltd., Drouin. Application to license one commercial passenger vehicle in respect of a 1987 Ford Fairlane sedan to be purchased with seating capacity for 5 passengers to operate as a country hire car from 40 Young Street, Drouin.

S. Janev, Surrey Hills. Application to license one commercial passenger vehicle in respect of a 1980 Mercedes Benz sedan with seating capacity for 5 passengers to operate as a special purpose vehicle from 45 Broughton Road, Surrey Hills for the carriage of passengers for wedding parties.

*Note:* This application is made in conjunction with a similar application by R. Roccasalvo.

S. J. Pec, Cranbourne. Application to license one commercial passenger vehicle with seating capacity for 12 passengers to operate for the carriage of children between the Langwarrin Child Care Centre, 1 Veronica Street, Langwarrin and the following schools:

Wonnai Pre School—Larch Street, Langwarrin  
Long Street Pre-School—Long Street, Langwarrin.

Montessori Pre School—Malcolm Road, Langwarrin

St. Judes School—Warrandyte Road, Langwarrin

Langwarrin Primary School—Warrandyte Road, Langwarrin

Langwarrin Post Primary School—Warrandyte Road, Langwarrin

*Timetable:* 8.30 a.m. – 4.00 p.m.

*Fares:* Included in the overall charge of child minding fees.

E. J. & L. Pincini Pty. Ltd., Airport West. Application to license one commercial passenger vehicle to be purchased with seating capacity for 45 passengers to operate in substitution for but not in addition to existing TS and MC licences in the name of E. J. & L. Pincini Pty. Ltd.

R. Roccasalvo, Box Hill. Application to license one commercial passenger vehicle in respect of a 1980 Jaguar sedan with seating capacity for 5 passengers to operate as a special purpose vehicle from 22 Sweetland Road, Box Hill for the carriage of passengers for wedding parties.

*Note:* This application is made in conjunction with a similar application by S. Janev.

E. Szmolnik, Viewbank. Application to license one commercial passenger vehicle in respect of a 1973 Jaguar sedan with seating capacity for 4 passengers to operate as a special purpose vehicle from 10 Willa Avenue, Viewbank for the carriage of passengers for wedding parties.

G. Torney, Sunbury. Application to license one commercial passenger vehicle to be purchased with seating capacity for 45 passengers to operate as a metropolitan special service omnibus.

*Note:* The vehicle to be licensed would hold a minimum 3 star rating for charter purposes.

Dated 10 June 1987

M. KENT  
Group Manager  
Vehicle Licensing Branch  
and Regulation Strategies

I hereby give notice that on 28 May 1987, the Public Trustee filed Elections to Administer the following deceased persons' estates in accordance with section 17 of the *Public Trustee Act 1958*:

Dante, Thora, late of Ballarat, pensioner, died 9 February 1987.

Dennis, Dorothy, late of Honiton Place, 273 Dandenong Road, Windsor, pensioner, died 13 February 1987.

Hilditch, Dorothy Ida, formerly of Flat 10, 25 Gladstone Street, Moonee Ponds but late of Corondirk Home, 74A Maribyrnong Road, Moonee Ponds, widow, died 15 March 1987.

Innes, Annie Louisa, late of Flat 3, 1 Scarborough Drive, Moorabbin, pensioner, died 19 February 1987.

Majewski, Sophia, late of Western Suburbs Private Nursing Home, 44 Stephen Street, Yarraville, pensioner, died 19 October 1986.

Owen, Peter John, late of Stawell, pensioner, died 20 November 1986.

Rowe, Bruce, late of Sunbury, pensioner, died 17 February 1987.

Webb, Elaine Shirley, late of Sunbury, pensioner, died 25 January 1987.

Dated 3 June 1987

W. J. KILPATRICK, Public Trustee

Creditors, next of kin and others having claims against the estate of any of the under-mentioned deceased persons are required to send particulars of their claims to the Public Trustee, 168 Exhibition Street, Melbourne, Vic. 3000, the personal representative, on or before 13 August

1987 after which date the Public Trustee may convey or distribute the assets having regard only to the claims of which the Public Trustee then has notice:

Bond, Frances Ruth, late of Edgelea Private Nursing Home, 87 Chapel Street, St. Kilda, retired, died 8 February 1987.

Butler, Mary, late of 2 Baxter Street, Toorak, widow, died 20 April 1987.

Dante, Thora, late of Ballarat, pensioner, died 9 February 1987.

Dennis, Dorothy, late of Honiton Place, 273 Dandenong Road, Windsor, pensioner, died 13 February 1987.

Dilley, Mary, late of Hornsby, New South Wales, retired nurse, died 7 September 1986.

Fethney, Marjorie, late of 3 Gilsland Road, Murrumbeena, pensioner, died 31 March 1987.

Fox-Russell, Vivian, also known as Vivian Russell and Vivienne Russell, formerly of Moore Road, Baddaginnie, late of Benalla and District Memorial Hospital, Benalla, married woman, died 9 November 1986.

Hilditch, Dorothy Ida, formerly of Flat 10, 25 Gladstone Street, Moonee Ponds but late of Corondirk Home, 74A Maribyrnong Road, Moonee Ponds, widow, died 15 March 1987.

Innes, Annie Louisa, late of Flat 3, 1 Scarborough Drive, Moorabbin, pensioner, died 19 February 1987.

Majewski, Sophia, late of Western Suburbs Private Nursing Home, 44 Stephen Street, Yarraville, pensioner, died 19 October 1986.

Newell, Evelene May, also known as Evelene Newell, late of 35 Hume Street, Greensborough, widow, died 26 March 1987.

Owen, Peter John, late of Stawell, pensioner, died 20 November 1986.

Rowan, Michael James, in the will called Michael Rowan, late of 55 Bealiba Road, South Caulfield, retired P.M.G. motor driver, died 24 November 1986.

Rowe, Bruce, late of Sunbury, pensioner, died 17 February 1987.

Smith, Kevin Joseph, late of 111 Laura Avenue, Belmont, invalid pensioner, died 23 February 1987.

Stamford, Dorothy Hilda, formerly of Unit 8, 74 Croydon Road, Surrey Hills, late of 13 Chatham Road, Canterbury, retired ballet teacher, died 9 February 1987.

Webb, Elaine Shirley, late of Sunbury, pensioner, died 25 January 1987.

Dated 3 June 1987

W. J. KILPATRICK, Public Trustee

*Police Regulation Act 1958*  
VICTORIA POLICE FORCE

Determination No. 473 of the Police Service Board

The Police Service Board, in pursuance of the powers in that behalf conferred by the *Police Regulation Act 1958*, hereby makes the following Determination (that is to say):

1. The Determination No. 179 of the Police Service Board of 14 December 1971, and published in the *Government Gazette* of 25 January 1972, as amended, is hereby further amended as follows:

1.1 By deleting paragraph 14 (c) (iii) and substituting therefor the following new paragraph 14 (c) (iii)—

“(iii) Instrument Development and Maintenance Section.

(A) There shall be paid to the Officer or Sub-Officer in Charge of the Instrument Development and Maintenance Section, who holds a Royal Melbourne Institute of Technology Radio Trade (Digital) qualification or who has reached any other standard of competence approved by the Chief Commissioner or his delegate an allowance (inclusive of any other Special Duties Allowance) at the rate of \$2984 per annum.

(B) There shall be paid to a member while performing duties with the Instrument Development and Maintenance Section and who is the holder of at least a Royal Melbourne Institute of Technology Radio Trade (Digital) qualification or any other qualification approved by the Chief Commissioner or his delegate an allowance (inclusive of any other Special Duties Allowance) at the following rate:

First and Second Years	1409
Third and Fourth Years	1784
Fifth and Subsequent Years	2480

(D) There shall be paid to a member while performing duty with the Instrument Development and Maintenance Section and who has successfully completed courses of study or part thereof in the field of Electronic Mechanics as are approved by the Chief Commissioner or his delegate, an allowance (inclusive of any other Special Duties Allowance) at the following rate:

Pass in completed first year of study	648
Pass in completed second year of study	833

(E) There shall be paid to a member while performing duties with the Instrument Development and Maintenance Section of a trade or technical nature, an allowance (inclusive of any other Special Duties Allowance) at the following rate:

First Year	366
Second Year	554
Third and Subsequent Years	727”

This Determination shall come into operation on and from 7 June 1987.

Dated 2 June 1987

T. B. SHILLITO  
A Judge of the County Court of Victoria  
Chairman and Member of the Police Service Board

P. CARRIGAN  
Member of the Police Service Board

F. J. LESLIE  
Member of the Police Service Board

## Private Agents Act 1966

NOTICE OF RECEIPT OF APPLICATIONS FOR LICENCES UNDER THE PROVISIONS OF  
THE PRIVATE AGENTS ACT 1966

The Clerk(s) of the Magistrates' Court(s) as listed hereunder hereby give notice that applications, as under, have been lodged for hearing by the said Court(s) on the date(s) specified.

Any person desiring to object to any of such applications must—

- (a) lodge with the respective Clerk of the Magistrates' Court a notice in the prescribed form of his objection and of the grounds thereof;
- (b) cause a copy of such notice to be served personally or by post upon the applicant at least three days before the hearing of the application; and
- (c) send or deliver—
  - (i) where the objection is not made by the officer in charge of the police district in which the Court is situated—a copy of the notice to such officer; and
  - (ii) where the objection is not made by the Registrar or Deputy Registrar—a copy to the Registrar.

Full Name of Applicant*	Place of Abode of Applicant or Nominee	Name of Firm or Corporation	Address for Registration	Type of Licence	Date of Hearing
<b>MAGISTRATES' COURT, DANDENONG</b>					
Maher, Desmond John	16 Peckover Crt, Endeavour Hills	Francis Security Service	14 John Edgcumbe Way, Endeavour Hills	Watchman	22.6.87
Dated at Dandenong, 28 May 1987 G. EBERT, Clerk of the Magistrates' Court					
<b>MAGISTRATES' COURT, DANDENONG</b>					
Francis, Brian Trevor	14 John Edgcumbe Way, Endeavour Hills	Patrick Lewis Francis	14 John Edgcumbe Way, Endeavour Hills	Watchman	18.6.87
Dated at Dandenong, 28 May 1987 G. EBERT, Clerk of the Magistrates' Court					
<b>MAGISTRATES' COURT, SHEPPARTON</b>					
Kilian, K.	Kiota Rd, Toolamba	Armaguard	390 St Kilda Rd, Melbourne	Watchman	26.6.87
Dated at Shepparton, 3 June 1987 I. GRUMMITT, Clerk of the Magistrates' Court					
<b>MAGISTRATES' COURT, CAMBERWELL</b>					
Bakhach, Ahmed Chafic	27 Closter Ave, Ashwood		27 Closter Ave, Ashwood	Inquiry Agent	1.7.87
Dated at Camberwell, 3 June 1987 Clerk of the Magistrates' Court					

\*Or in the case of a firm or corporation, of the Nominee



## PRIVATE AGENTS—continued

Full Name of Applicant*	Place of Abode of Applicant or Nominee	Name of Firm or Corporation	Address for Registration	Type of Licence	Date of Hearing
<b>MAGISTRATES' COURT, KYNETON</b>					
Buckley, Anne Colynne	16 Windridge Way, Kyneton		16 Windridge Way, Kyneton	Commercial Agent	23.6.87
Buckley, Michael John	"		"	"	"
Dated at Kyneton, 1 June 1987 K. ADDICOAT, Clerk of the Magistrates' Court					
<b>MAGISTRATES' COURT, OAKLEIGH</b>					
Anderson, Alexander Walter	280 Balcombe Rd, Beaumaris		2 Esper Ave, Sth Oakleigh	Process Server Inquiry Agent	2.6.87
"	"		"	"	"
Chandivert, Peter William	5 Logie St, Oakleigh		P.O. Box 188 East Bentleigh	Watchman	18.6.87
Dated at Oakleigh, 25 May 1987 B. LAWRENCE, Clerk of the Magistrates' Court					
<b>MAGISTRATES' COURT, WARRAGUL</b>					
Brinsmead, Gregory James	13-15 Montrose St, Warragul		13-15 Montrose St, Warragul	Guard Agent (Ind.)	8.7.87
" "	"	Pebarn Pty. Limited	"	Guard Agent (Corp.)	"
Dated at Warragul, 25 May 1987 HOWARD McINNES, Clerk of the Magistrates' Court					
<b>MAGISTRATES' COURT, PRESTON</b>					
Summers, Gary Jonathon	15 Djerriwarrah Crt, Melton		7/294 High St, Preston	Watchman	18.6.87
Dated at Preston, 22 May 1987 R. McHUGH, Clerk of the Magistrates' Court					
<b>MAGISTRATES' COURT, SPRINGVALE</b>					
Hansen, Neil Joseph	99 Darling Way, Narre Warren		841 Springvale Rd, Mulgrave	Watchman	24.6.87
Dated at Springvale, 27 May 1987 M. LEA, Clerk of the Magistrates' Court					
<b>MAGISTRATES' COURT, BENDIGO</b>					
Harman, Andrew James	18 Bolt St, Long Gully		174 Holdsworth Rd, Bendigo	Watchman	22.6.87
Dated at Bendigo, 28 May 1987 T. J. NIHILL, Clerk of the Magistrates' Court					

\*Or in the case of a firm or corporation, of the Nominee

## PRIVATE AGENTS—continued

Full Name of Applicant*	Place of Abode of Applicant or Nominee	Name of Firm or Corporation	Address for Registration	Type of Licence	Date of Hearing
<b>MAGISTRATES' COURT, HEIDELBERG</b>					
Martin, David Ronald	10/77 St. James Rd, Rosanna		19 Edwards St, Lower Plenty	Watchman	3.7.87
Dated at Heidelberg 5 June 1987 D. GEAR, Clerk of the Magistrates' Court					
<b>MAGISTRATES' COURT, SUNSHINE</b>					
Anderson, Ian Charles	10/7 Fabian Crt, Maribyrnong		10/7 Fabian Crt, Maribyrnong	Guard Agent	10.7.87
Dated at Sunshine 4 June 1987 R. NIEMER, Clerk of the Magistrates' Court					
<b>MAGISTRATES' COURT, WERRIBEE</b>					
Knowles, Terrence Colin	36 Coronet St, Flemington		85 Bindowan Dr, Hoppers Crossing	Watchman	9.7.87
Mariani, Mark Simon	41 Lower Rd, Eltham		78-118 Cherry La, Laverton	Guard Agent	2.7.87
Dated at Werribee 2 June 1987 Clerk of the Magistrates' Court					
<b>MAGISTRATES' COURT, MORDIALLOC</b>					
Hargreaves, Sharon Lee	143 Ballarto Rd, Carrum Downs		249 Station St, Edithvale	Watchman	7.7.87
Dated at Mordialloc 1 June 1987 K. PHELAN, Clerk of the Magistrates' Court					
<b>MAGISTRATES' COURT, HEIDELBERG</b>					
Bailey, Michael Edward	9/74 Hawdon St, Heidelberg		9/74 Hawdon St, Heidelberg	Guard Agent	29.6.87
Dated at Heidelberg 1 June 1987 D. GEAR, Clerk of the Magistrates' Court					

\*Or in the case of a firm or corporation, of the Nominee

## HEALTH ACT 1958

Supplement to the Register of Contraceptives published in the *Government Gazette* in accordance with the Provisions of Section 270H (5) of the *Health Act 1958*

Serial No.	Date of Registration	Distinctive Name	Name and Address of Applicant	Proprietary Medicine Reg. No.
C230	22.5.1987	Liberty—Creme Special (10 Pack)	AMCLA Pty. Ltd., 41 Whiting Street, Artarmon, N.S.W. 2064.	—

G. J. ROUCH  
Health Department, Victoria

*Groundwater (Border Agreement) Act 1985*  
**DECLARATION UNDER SUB-CLAUSE 28  
 (2) OF THE BORDER GROUNDWATERS  
 AGREEMENT**

Notice is hereby given, as required by Clause 31 of the Border Groundwaters Agreement, that the Border Groundwaters Agreement Review Committee declares, by virtue of its powers under sub-clause 28 (2) of the Agreement, that the permissible annual volumes of extraction set out in the Second Schedule to the said Agreement are hereby varied, to the extent set out in the schedule to this declaration, with effect from the date of publication of this declaration in the *Government Gazette*.

The Schedule

Zone	Permissible Annual Volume (M1)	
	Varied,	
	from	to
7A	5700	7000
7B	5700	7000

Dated 31 March 1987

For and on behalf of Border Groundwater Agreement Review Committee

HAROLD TUCKWELL  
 President, Border Groundwater Agreement Review Committee

**REGULATIONS FOR THE CARE,  
 PROTECTION AND MANAGEMENT OF  
 "CHIRNSIDE PUBLIC RECREATION  
 RESERVE"**

I, Joan Elizabeth Kirner, Her Majesty's Minister for Conservation, Forests and Lands in and for the State of Victoria, in pursuance of the powers conferred on me by section 13 of the *Crown Land (Reserves) Act 1978* do hereby make the following Regulations for or with respect to the Crown Land in the Township of Werribee, Parish of Deulgam (hereinafter referred to as the "Reserve") temporarily reserved as a site for Public Recreation in respect of which a Committee of Management (hereinafter referred to as the "Committee") has been appointed.

Regulations

1. The Reserve shall be open to the public from sunrise to sunset free of charge, except on such days, not exceeding fifty-two (52) in any one year, as the Reserve may be set apart for cricket, tennis, or football matches, bowls, and any other sporting activities, fetes or entertainments, on any of which occasions a sum as determined by the Committee may be charged and taken for the admission of every adult to the Reserve.

2. No person shall—

- (a) Enter or remain in the Reserve who offends against decency as regards dress, language, or conduct, or who behaves in a disorderly, unseemly or offensive manner, or creates or takes part in any disturbance;
- (b) Use indecent or offensive language in the Reserve;
- (c) Offer any article of food or drink or any other commodity whatsoever for sale, or bring any intoxicating liquor on to the Reserve, without the consent of the Committee first obtained;
- (d) Obstruct, hinder, or interfere with any person employed by the Committee on the Reserve;
- (e) Climb, jump on, or get over any of the gates or fences in or around the Reserve, stick bills or advertisements or cut names thereon, or in any way damage or injure any of the buildings, furniture, fittings, gates, stiles, seats, or other structures in the Reserve;
- (f) Interfere with, break, or damage in any way any of the trees, shrubs or plants, or pick any of the flowers, or walk on the beds or borders in the Reserve;
- (g) Leave or deposit any bottles, broken glass, paper, refuse, or rubbish whatsoever in the Reserve;
- (h) Light a fire in the Reserve except at such places as are set apart for the purpose by the Committee;
- (i) Carry or discharge any firearms or air-gun in the Reserve, or shoot, snare or destroy any game or birds therein, without the consent of the Committee first obtained;
- (j) Carry on the trade, business, or occupation of a bookmaker in the Reserve without the permission, in writing, of the Committee or its authorized officer first obtained, and then only in such portion or portions thereof as may be set apart for that purpose by the Committee;
- (k) Erect any building, tent or structure, or camp on any portion of the Reserve without permission, in writing, of the Committee first obtained, and then only under such conditions as may be determined by the Committee;
- (l) Remain in the Reserve at any time when lawfully directed by an officer or employee of the Committee to leave the same;
- (m) Take or put, or allow to be taken or put into the Reserve any horses, cattle, sheep, goats, pigs, or other animals;

- (n) Train or exercise any horse or dog in the Reserve without the approval of the Committee having first been obtained;
- (o) Bring or allow to remain in the Reserve any dog, unless such dog is controlled by a chain or cord or is partaking in training permitted by the Committee;
- (p) Walk on the bowling greens or tennis courts at anytime, unless entitled to use the same, as provided in Regulation No. 4 hereof and unless wearing rubber-soled footwear without heels.

3. No person or club shall play, practice or engage in any game or sport within the Reserve without the consent, in writing, of the Committee or a duly authorised officer thereof first obtained, and then only in such portion or portions of the Reserve as may be set aside for the purpose by the Committee.

This Regulation shall not prohibit a person or group of persons from playing any game or sport in the Reserve which does not interfere with any other person, any permitted and approved of activity in the Reserve or within the buildings on the Reserve, grounds, vegetation, equipment, amenities, or other use of the Reserve.

4. No person shall be entitled to play any game or practice, or take part in such practice, in any part or division of the Reserve, unless he be a member or authorized guest of one of the clubs that have been granted permission, in writing, to play or practise, as the case may be, by the Committee of Management.

Provided that any person not otherwise offending against these Regulations may enter on the Reserve and play tennis thereon, on paying to the club or association for the first time being permitted to use the Reserve, or to the Committee of Management (as the cost may be) a reasonable amount as court fee.

5. No person, not being a player or official, shall trespass on the playing area during the progress of any cricket, tennis, bowls, or football matches, or any sports gathering, nor wilfully obstruct, interrupt, or in any way interfere with any employee of the Committee in the proper execution of his work or duty.

6. The Committee shall have power to let any portion of the Reserve to any club, association, or person for the purpose of holding fetes, entertainments, musical performances, shows or sports, or any athletic training or other physical recreation, subject to the payment of such fees, and on such terms and conditions as it may deem reasonable and consistent with these Regulations, and to authorise any club, association, or person to make a charge for admission thereto as hereinbefore provided.

7. No person, except the Committee or its officers and employees on duty, shall enter any part of the Reserve when a charge is made for admission, without first paying the fees chargeable for such admission.

8. No person shall park a motor car or motorcycle within the Reserve except at such places as are set apart for the purpose, and any person using any such place for parking a motor cycle or motor car shall, on demand by an authorised officer of the Committee, pay such fee as is from time to time determined by such Committee, in respect of any such car or cycle, for the use of such parking area on such days only as a charge for admission is being made as hereinbefore provided.

9. The Committee may set apart a portion or portions of the Reserve as and for the purpose of a camping area, and may fix and collect fees or other charges for entering and use of any such area as hereinafter provided.

10. The fees for use of a camping area shall be such sum as the Committee may determine.

11. The Committee may set apart a portion or portions of the Reserve as and for the purpose of a picnic area and may fix and collect fees or other charges for entering and use of any such area as hereinafter provided.

12. The fee for the use of a picnic area in the Reserve shall be such sum as the Committee may determine.

Given under my Hand at Melbourne on 28 May 1987.

J. E. KIRNER

Minister for Conservation, Forests and Lands

Every person who contravenes or fails to comply with these Regulations shall be liable to the penalties prescribed in section 13 of the *Crown Land (Reserves) Act 1978*.

*Crown Land (Reserves) Act 1978*  
PROPOSED REVOCATION OF  
TEMPORARY RESERVATION OF LAND  
BY ORDER IN COUNCIL

Notice of Intention

In pursuance of the provisions of section 10 of the *Crown Land (Reserves) Act 1978*, notice is hereby given that it is the intention of the Governor in Council to revoke the temporary reservation of land by Order in Council hereunder referred to, viz:

ILLAWARRA—The temporary reservation by Order in Council of 17 January 1928 of 87.6 hectares more or less in the Parish of Illawarra as a site for the Supply of Gravel—(Rs 621).

ILLAWARRA—The temporary reservation by Order in Council of 18 January 1875 of 2 hectares more or less in the Parish of Illawarra as a site for Watering Purposes—(L4-1280).

ILLAWARRA—The temporary reservation by Order in Council of 4 June 1877 of 3.64 hectares more or less in the Parish of Illawarra as a site for a Reservoir—(L4-1280).

J. E. KIRNER  
Minister for Conservation, Forests and Lands

	\$
Grave digging	110.00
Land	50.00
Fees	35.00

C. H. TAYLOR, Trustee  
G. W. BALSARINI, Trustee  
G. M. POLINELLI, Trustee

Approved by the Governor in Council, 2 June 1987—E. M. MILLER, Acting Clerk of the Executive Council

*Cemeteries Act 1958*

SCALE OF FEES OF THE NATIMUK  
PUBLIC CEMETERY

In pursuance of the powers conferred upon them by the Cemeteries Act the trustees of the Natimuk Public Cemetery hereby make the following scale of fees, which shall come into operation upon publication in the *Government Gazette*, and from and after such publication every scale of fees heretofore made by the said trustees shall be and is hereby rescinded to the extent to which it conflicts with this scale.

	\$
Sinking Grave 1.83 m deep	110.00
Reopening Grave	110.00
Land	60.00
Permission to erect a headstone or monument—5 per cent of cost with a minimum of \$10.00	
Permission to construct a brick grave or to erect any stone kerb, brick tile-work or concrete—	
Exhuming the remains of a body (when authorised)	200.00

J. D. KORTH, Trustee  
R. E. LIEBERGANG, Trustee  
M. L. SCHMIDT, Trustee

Approved by the Governor in Council, 2 June 1987—E. M. MILLER, Acting Clerk of the Executive Council

*Cemeteries Act 1958*

SCALE OF FEES OF THE ULTIMA PUBLIC  
CEMETERY

In pursuance of the powers conferred upon them by the Cemeteries Act the trustees of the Ultima Public Cemetery hereby make the following scale of fees, which shall come into operation upon publication in the *Government Gazette*, and from and after such publication every scale of fees heretofore made by the said trustees shall be and is hereby rescinded to the extent to which it conflicts with this scale.

TAFE TEACHING SERVICE

Election for two (2) members and three (3) deputy members of the TAFE Teaching Service Registration Board.

Election for the members and deputies of the abovenamed Board have been conducted, the closing date being 4.00 pm on Friday 29 May 1987, and as a result of this election I declare the following members of the TAFE Teaching Service duly elected.

*TAFE Teaching Service Registration Board Members—*

Brian Lawrence Dunn (Box Hill College of TAFE)

John James Westerdale (Melbourne College of Textiles)

*TAFE Teaching Service Registration Board Deputy Members—*

John Alexander Forbes (Gordon Technical College)

Peter Frederick Furniss (Batman Automotive College of TAFE)

Alan Metcalfe (Melbourne College of Decoration)

MARIANA BRKICH, Returning Officer

*Public Service Act 1974*

ACTING SUPERINTENDENT OF VERMIN  
AND NOXIOUS WEEDS DESTRUCTION  
Notice of Appointment

Notice is given that Mr Kenneth Charles McNeill is appointed under the *Public Service Act 1974* to be the person for the time being performing the duties of the Superintendent of Vermin and Noxious Weeds Destruction pursuant to section 4 of the *Vermin and Noxious Weeds Act 1958* from 1 January 1985 to 30 June 1987.

GERRY GRIFFIN  
Acting Director-General, Department of  
Conservation, Forests and Lands

*Industrial Relations Act 1979*NOTICE OF APPLICATION FOR  
RECOGNITION AS AN ASSOCIATION

Notice is hereby given that the following associations have filed applications to be recognised as an association under the *Industrial Relations Act 1979* with respect to trades for which the following Conciliation and Arbitration Boards have been appointed:

Association	Board
Milk Processors' Association of Victoria Inc.	Carters and Drivers of Commercial Clerks Retail Dairy
Bread Manufacturers Association	Food Shops Pastrycooks

Pursuant to Regulation 33 (5) of the Industrial Relations Regulations any recognised association or person interested may on or before 9 July 1987, file in the Registry (Level 18, Napra House, 80 Collins Street, Melbourne) an objection to the application.

The objection shall be in, or to the effect of Form 9 prescribed by the Regulations.

A. S. DOWLING, Deputy Registrar  
Industrial Relations Commission of Victoria

*Industrial Relations Act 1979*INDUSTRIAL RELATIONS COMMISSION  
OF VICTORIA

Award of the Hairdressers and Beauty Industry  
Conciliation and Arbitration Board  
No. 1 of 1987

Notice is hereby given that an appeal to the Industrial Relations Commission of Victoria has been lodged against Award No. 1 of 1987 made on 10 December 1986 by the Hairdressers and Beauty Industry Conciliation and Arbitration Board.

In particular the appeal is against the following part or parts of the Award:

To subclause (b) (Times of Beginning and Ending Work) of Clause 4 (Hours of Work and Rosters) add the following paragraph—

On a Saturday the rate of pay between the hours of noon and 1.00 p.m. shall be time and a half and the rate after 1.00 p.m. shall be double time.

To subclause (a) of Clause 5, (Overtime) add the following paragraph—

provided that on a Saturday the rate of pay between the hours of noon and 1.00 p.m. shall be time and a half, and after 1.00 p.m. shall be double time.

Section 16 (3) of the *Industrial Relations Act 1979* provides that if an appeal is lodged under this section, the award or part of the award appealed against, shall be deemed not to have come into operation until the appeal is dealt with by the Commission or the appeal is withdrawn.

A. S. DOWLING  
Deputy Registrar

Industrial Relations Commission of Victoria

STATE TENDER BOARD  
CONTRACTS ACCEPTED  
Amendments

Schedule Number	Item Number	New Rate	Effective Date
<i>Supply and Delivery of Motor Vehicles</i>			
1/58A	A	8635.00	8.6.87
optional Equipment—			
Automatic Transmission		651.00	
1/58B	A	8466.00	
Optional Equipment—			
Automatic Transmission		651.00	
1/58F		10200.00	
Optional Equipment—			
Automatic Transmission		710.00	
1/58J	A	13216.00	
1/58K	C	18325.00	

J. M. PAWSON  
Secretary to the Tender Board

CONTRACTS ACCEPTED (Series 1986-87)  
PUBLIC WORKS

Croydon City—Building works, Croydon North Primary School—\$78 208.00—Floline Decorative Finishes Pty. Ltd., 22 Shelley Avenue.

Lillydale Shire—Building works, Pembroke High School—\$57 830.00—K. C. & B. S. McDermott, Mooroolbark.

Melbourne City—Demolish L. 16-21 and AG/SEC fitout 19 and 21, Melbourne, 200 Queen Street, (Attorney-General)—\$166 250.00—Quadric Pty. Ltd., North Melbourne.

Melbourne City—Alteration work contract, Melbourne, 328 Swanston Street (State Library)—\$208 850.00—Ayjay Construction, Farleigh Court.

Mildura Shire—Renovations, Nichols Point Primary School—\$121 824.58—S. J. Weir Pty. Ltd. (Mildura), Mildura.

Otway Shire—Cyclic maintenance, siteworks, Lavers Hill Consolidated School—\$81 791.00—Rodger & Vickers Pty. Ltd., Colac.

Rosedale Shire—Cyclic maintenance contract, Cowwarr Primary School—\$57 615.00—W. G. Campbell Constructions Pty. Ltd., Morwell.

Various—Maintenance of natural gas burners 1987/ Annual services—South Central Metro—\$75 391.00—Gas and Fuel Corporation (Commercial Sales), 171 Flinders Street, Melbourne.

Various—Supply and delivery of modular buildings, various school locations—“RATES”—Bendigo Re-Locatable Buildings, Bendigo.

Various—Supply and delivery of modular buildings, various school locations—“RATES”—Mod Kon Constructions Pty. Ltd., Ballarat.

Dated 2 June 1987

J. DEVENISH  
Director General of Public Works

#### ERRATUM

##### Acts of Parliament

In *Government Gazette* No. G20 of 27 May 1987 on page 1235, the reference given to the year of the House Contracts Guarantee Act was “1977”, this should have read “1987”.

#### Education Act 1958

##### NOTICE OF THE MAKING OF AN ORDER UNDER SECTION 13 (1) OF THE ACT

Pursuant to section 13 of the *Education Act* 1958 I hereby give notice that an Order of the Governor in Council was made on 2 June 1987 under sub-section (1) of the said Act constituting a council for the Laverton Primary School.

IAN CATHIE  
Minister for Education

#### Education Act 1958

##### NOTICE OF THE MAKING OF AN ORDER UNDER SECTION 13 (1) OF THE ACT

Pursuant to section 13 of the *Education Act* 1958 I hereby give notice that Orders of the Governor in Council were made on 2 June 1987 under sub-section (1) of the said Act constituting councils for the State schools listed below:

5267 Sunshine Special Developmental School  
5268 Swan Hill Special Developmental School

IAN CATHIE  
Minister for Education

#### Education Act 1958

##### NOTICE OF THE MAKING OF AN ORDER UNDER SECTION 13 (4) OF THE ACT

Pursuant to section 13 of the *Education Act* 1958 I hereby give notice that Orders of the Governor in Council were made on 2 June 1987 under sub-section (4) of the said Act amending certain provisions relating to the School Councils listed below:

266 Glenlyon Primary School  
415 Mount Macedon Primary School  
531 Rokewood Primary School  
1243 Gerangamete Primary School  
1510 Sebastian Primary School  
2182 Tyers Primary School  
4681 Herne Hill Primary School  
5214 St. Albans School for Deaf Children Special School  
5245 Loch Sport Primary School  
6203 Apollo Bay Higher Elementary School  
6231 Lavers Hill Consolidated  
7160 Geelong Technical School  
7980 Lakeside High School

IAN CATHIE  
Minister for Education

Notice is hereby given that in accordance with sub-section 36 (2) of the *Associations Incorporations Act* 1981, the incorporation of Complementary Health Practitioners Association Inc., Dimboola High Tennis Club Inc., Donald Summer Badminton Club Inc., Koroit Cultural & Sporting Complex Inc., The Kyneton and District Hardcourts Tennis Association Inc., Pritikin Lifestyle Association Inc., Radius Victoria Inc., Waverley Christian Community Ministries Inc., Bushfield Football Club Inc., Westvale Community Centre Inc., The Yarra Valley Garden Club Inc., and St. Andrews Tennis Club Inc., was cancelled on 22 May 1987.

GORDON LEWIS  
Registrar of Incorporated Associations

#### RETIREMENT VILLAGES REGULATIONS 1987

It is my intention to proceed to recommend to the Governor in Council that the Retirement Villages Regulations 1987 be made.

J. H. KENNAN  
Attorney-General

## APPOINTMENTS

### *Liquor Control Act 1968* APPOINTMENT OF LICENSING INSPECTORS

In accordance with the authority conferred upon me by section 6 of the *Police Regulation Act 1958, I*, Paul Delianis, Deputy Commissioner of Police do hereby appoint under sub-section (1) of section 22 of the *Liquor Control Act 1968*, the following Officers of Police as Licensing Inspectors for the Divisions of the Police Districts as shown:

<i>Division Police Number District</i>	<i>Rank and Name</i>
2 Cheltenham	Inspector Ian Findlay Fountain, 14304 ( <i>vice</i> Chief Inspector Stevens, 12745)
2 Melbourne	Inspector Ian Leonard Clarke Baker, 15528 (from 27 May to 15 June 1987)
3 Prahran	Inspector Donald Geoffrey Welsford, 13854 ( <i>vice</i> Chief Inspector Hopkins, 11958)
2 Westernport	Inspector Kenneth Herbert Blay, 13750 (from 10 to 30 May 1987)
2 Wimmera	Senior Sergeant Peter John Mintern-Lane, 14738 (from 27 May to 17 June 1987)

Dated 4 June 1987

P. DELIANIS  
Deputy Commissioner (Administration)

### *Mental Health Act 1959* SECTION 26

Notice is hereby given that the following appointment has been made pursuant to section 26 of the *Mental Health Act 1959*:

Terrence Alfred Carr, Deputy Manager, Ararat Mental Hospital and Training Centre from 2 June 1987, *vice* R. J. Siesmaa.

T. J. DALY  
Director  
Office of Psychiatric Services

### *Liquor Control Act 1968* APPOINTMENT OF LICENSING INSPECTORS

In accordance with the authority conferred upon me by section 6 of the *Police Regulation Act 1958, I*, Paul Delianis, Deputy Commissioner of Police, do hereby appoint under sub-section (1) of section 22 of the *Liquor Control Act 1968*, the following Officers of Police as Licensing Inspectors for the Divisions of the Police Districts as shown:

<i>Division Police Number District</i>	<i>Rank and Name</i>
2 Altona	Inspector Graeme Charles McDonald, 15680 (from 7.6.1987 to 11.7.1987)
1 Essendon	Inspector John Martin, 14946 (from 24.5.1987 to 20.6.1987)
1 Maroondah	Chief Inspector William Jackson, 12372 ( <i>vice</i> Superintendent Price, 10805)
1 Maroondah	The appointment of Chief Inspector Russell Louis Bertram, 12215 is withdrawn, result of appeal.

Dated 1 June 1987

P. DELIANIS  
Deputy Commissioner (Administration)

### APPOINTMENT

His Excellency the Governor of the State of Victoria by and with the advice of the Executive Council thereof has by order made on 2 June 1987 been pleased to make the undermentioned appointment, viz:

#### *Attorney-General*

Commissioner for Taking Affidavits

Michael George BEASLEY, 221 Queen Street, Melbourne

to be a Commissioner for taking Affidavits pursuant to section 114 (1) of the *Evidence Act 1958*.

E. M. MILLER  
Acting Clerk of the Executive Council  
At the Executive Council Chamber  
Melbourne, 2 June 1987



**ORDERS IN COUNCIL**

*Crown Land (Reserves) Act 1978*  
**CROWN LAND PERMANENTLY RESERVED**

The Governor in Council under sections 4 and 7 of the *Crown Land (Reserves) Act 1978* permanently reserves for the purpose mentioned and also excepts from prospecting or from occupation for mining purposes under any miners right the following Crown land:

**MUNICIPAL DISTRICT OF THE SHIRE OF OTWAY**

**AIRE**—For management of Wildlife 70 hectares more or less being Crown Allotment 21G in the Parish of Aire as indicated by hatching on plan hereunder—(A 176 (5)) (Rs. 11225).

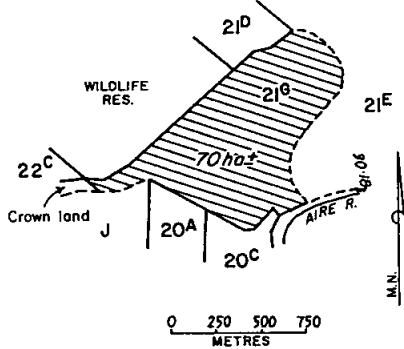

Dated 2 June 1987  
 Responsible Minister:  
**JOAN E. KIRNER**  
 Minister for Conservation, Forests and Lands  
**E. M. MILLER**  
 Acting Clerk of the Executive Council

*Land Act 1958*  
**UNUSED ROADS CLOSED**

The Governor in Council under section 349 of the *Land Act 1958* and with the consent in writing of the municipalities concerned closes the following unused roads:

**MUNICIPAL DISTRICT OF THE SHIRE OF ARARAT**

Parish of Watgania being the road indicated by hatching on plan hereunder—(W263 (3)) (L3-1555).

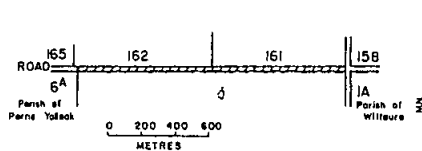

**MUNICIPAL DISTRICT OF THE SHIRE OF SWAN HILL**

Parish of Turoar being the road indicated by hatching on plan hereunder—(T283 (3)) (Rs. 12632).

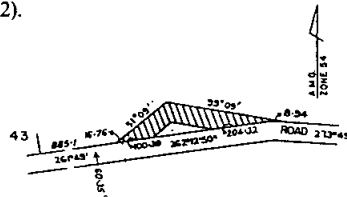

Dated 2 June 1987  
 Responsible Minister:  
**JOAN E. KIRNER**  
 Minister for Conservation, Forests and Lands  
**E. M. MILLER**  
 Acting Clerk of the Executive Council

*Land Act 1958*  
**UNUSED ROAD CLOSED**

The Governor in Council under section 349 of the *Land Act 1958* and with the consent in writing of the municipality concerned and the adjoining owner closes the following unused road:

**MUNICIPAL DISTRICT OF THE SHIRE OF RIPON**

**BEAUFORT**—The road in the Township of Beaufort, Parish of Beaufort shown as Crown Allotment 20A, section 4, on Certified Plan No. 108356 lodged in the Central Plan Office—(L3-575).

Dated 2 June 1987  
 Responsible Minister:  
**JOAN E. KIRNER**  
 Minister for Conservation, Forests and Lands  
**E. M. MILLER**  
 Acting Clerk of the Executive Council

*Urban Land Authority Act 1979*  
**TRANSFER OF LAND**  
 Eltham North

The Governor in Council under section 19 (1) of the *Urban Land Authority Act 1979* transfers to the Urban Land Authority the land described in the Schedule.

**Schedule**

The land marked A on the plan hereunder being part of Lot 1 on Plan of Subdivision No. 57492 Parish of Nillumbik County of Evelyn and being part of the land more particularly described in Certificate of Title Volume 8407 Folio 144.

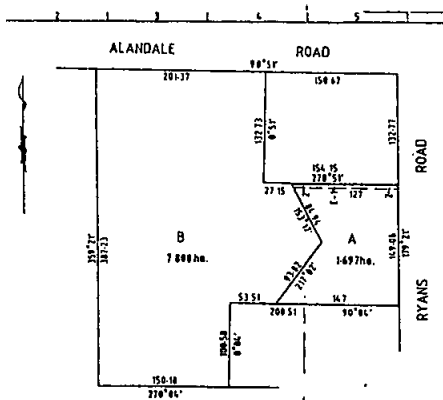

Dated 2 June 1987

Responsible Minister:  
**FRANK NOEL WILKES**  
Minister for Housing

**E. M. MILLER**  
Acting Clerk of the Executive Council

**Urban Land Authority Act 1979**  
**TRANSFER OF LAND**  
Langwarrin

The Governor in Council under section 19 (1) of the *Urban Land Authority Act 1979* transfers to the Urban Land Authority the land described in the Schedule.

**Schedule**

Parish of Langwarrin  
County of Mornington

Lot No.	Plan of Subdivision	Certificate of Title Volume	Folio
2	97050	9069	003

Dated 2 June 1987

Responsible Minister:  
**FRANK NOEL WILKES**  
Minister for Housing

**E. M. MILLER**  
Acting Clerk of the Executive Council

*River Improvement Act 1958*

**EXTENSION OF THE MITCHELL RIVER IMPROVEMENT DISTRICT**

The Governor in Council under section 17 of the *River Improvement Act 1958* orders that on and from 1 October 1987—

1. The Mitchell River Improvement District delineated and bordered red on Plan A accompanying this Order in Council shall be extended to include such of those lands within the watersheds of the Mitchell River and certain adjacent streams as are delineated and bordered red on Plan B accompanying this Order.

2. The Mitchell River Improvement District so extended shall form a new district to be known as the Mitchell River Management District.

3. The Mitchell River Management District so formed shall be under the control and jurisdiction of the Mitchell River Management Board.

4. The Mitchell River Management Board shall be comprised of eight Commissioners and of these one shall be elected by each of the Councils of the Town of Bairnsdale, the Shire of Bairnsdale and the Shire of Avon and five shall be appointed by the Minister.

5. All assets, debts and liabilities of the former Mitchell River Improvement Trust shall be the responsibility of the Mitchell River Management Board.

6. The Rating Divisions of the former Mitchell River Improvement District as determined by an Order in Council made on 14 January 1964 published in the *Government Gazette* dated 15 January 1964 shall be repealed.

Dated: 2 June 1987

Responsible Minister:  
**A. McCUTCHEON**  
Minister for Water Resources

**E. M. MILLER**  
Acting Clerk of the Executive Council

*Water Act 1958*

**RURAL WATER COMMISSION OF VICTORIA**

**ABOLITION OF KERANG NORTH-WEST LAKES WATERWORKS DISTRICT AND EXTENSION OF KERANG IRRIGATION AREA OF GOULBURN-MURRAY IRRIGATION DISTRICT**

The Governor in Council, under section 94 (ba) of the *Water Act 1958*, on the recommendation of the Rural Water Commission of Victoria, directs that as from the date hereunder the Kerang North-West Lakes

Waterworks District shall be abolished and the portions of that District shown by blue colour on the accompanying plan (Corr. No. 78/3203) shall be added to the Kerang Irrigation Area of the Goulburn-Murray Irrigation District.

Dated: 2 June 1987

Responsible Minister:

ANDREW McCUTCHEON  
Minister for Water Resources

E. M. MILLER  
Acting Clerk of the Executive Council

*Water Act 1958*

RURAL WATER COMMISSION OF  
VICTORIA

Extension of Expiry Date for the Allocation of Extra Water Rights in Irrigation Districts under Schedule Three B of the Water Act

The Governor in Council fixes 1 July 1989 as the date referred to in section 65c (1) of the *Water Act 1958* as the date upon which it shall be deemed that the volume of extra water right apportioned to any land in accordance with the provisions of Schedule Three B of the Act shall be sufficient for the reasonable irrigation of so much of such land as is under intense culture.

Dated: 2 June 1987

Responsible Minister:

ANDREW McCUTCHEON  
Minister for Water Resources

E. M. MILLER  
Acting Clerk of the Executive Council

*Water and Sewerage Authorities (Restructuring)  
Act 1983*

GEELONG AND DISTRICT WATER  
BOARD

Extent of Drysdale-Clifton Springs Sewerage District Increased

The Governor in Council, under the provisions of the *Water and Sewerage Authorities (Restructuring) Act 1983*, approves of the extension of the Drysdale-Clifton Springs Sewerage District of the Geelong and District Water Board as shown by pink colour on the accompanying plan—(Corr. No. P86/133).

Dated 2 June 1987

Responsible Minister:

ANDREW McCUTCHEON  
Minister for Water Resources

E. M. MILLER  
Acting Clerk of the Executive Council

*Libraries Act 1958*

AUTHORITY TO TRANSFER LAND

The Governor in Council under section 23 of the *Libraries Act 1958* authorises Ronald Stewart Ristrom and Charles Rupert Jones the trustees for the time being of the Rushworth Mechanics' Institute and Free Library to transfer the land described in Certificate of Title volume 6229 folio 727 to the President, Councillors and Ratepayers of the Shire of Waranga.

Dated 2 June 1987

Responsible Minister:

CHARLES RACE THORSON MATHEWS  
Minister for the Arts

E. M. MILLER  
Acting Clerk of the Executive Council

*Crown Land (Reserves) Act 1978*

REVOCATION OF TEMPORARY  
RESERVATION

The Governor in Council under section 10 of the *Crown Land (Reserves) Act 1978* revokes the following temporary reservation:

SANDHURST—The temporary reservations by Orders in Council of 13 July 1942 and 22 August 1956 of 1.98 hectares more or less in the Parish of Sandhurst as a site for the purposes of Public Recreation and Public Hall so far only as the portion containing 2035 square metres being Crown Allotment 416D, section H, Parish of Sandhurst as shown on Certified Plan No. 108158 lodged in the Central Plan Office—(Rs. 4599).

Dated 2 June 1987

Responsible Minister:

JOAN E. KIRNER  
Minister for Conservation, Forests and Lands

E. M. MILLER  
Acting Clerk of the Executive Council

*Crown Land (Reserves) Act 1978*

REVOCATION OF TEMPORARY  
RESERVATIONS

The Governor in Council under section 10 of the *Crown Land (Reserves) Act 1978* revokes the following temporary reservations:

BOORT—The temporary reservation by Order in Council of 29 July 1940 of 4.04 hectares, more or less, of land in the Township of Boort, Parish of Boort as a site for Plantation Purposes so far only as the portion containing 3067 square metres being Crown Allotment 2, section 13, Township of Boort as shown on Certified Plan No. 107857 lodged in the Central Plan Office—(Rs. 5071).

**QUEENSLIFF**—The temporary reservation by Order in Council of 14 April 1885 of 1523 square metres of land in the Township of Queenscliff, Parish of Paywit as a site for Railway Purposes so far only as the area of 1300 square metres, more or less, shown by hatching on the plan published in the *Government Gazette* of 13 May 1987 on page 1113—(Rs. 5781).

Dated 2 June 1987

Responsible Minister:

JOAN E. KIRNER

Minister for Conservation, Forests and Lands

E. M. MILLER

Acting Clerk of the Executive Council

*Crown Land (Reserves) Act 1978*

**CROWN LAND TEMPORARILY RESERVED**

The Governor in Council under sections 4 and 7 of the *Crown Land (Reserves) Act 1978* temporarily reserves for the purpose mentioned and also excepts from prospecting or from occupation for mining purposes under any miners right the following Crown land:

**PAYWIT**—Park and Recreation, 3187 square metres being Crown Allotment 7, section 43, Parish of Paywit as shown on Certified Plan No. 73272 lodged in the Central Plan Office—(Rs. 13493).

Dated 2 June 1987

Responsible Minister:

JOAN E. KIRNER

Minister for Conservation, Forests and Lands

E. M. MILLER

Acting Clerk of the Executive Council

*Crown Land (Reserves) Act 1978*

**REVOCATION OF TEMPORARY RESERVATION**

The Governor in Council under section 10 of the *Crown Land (Reserves) Act 1978* revokes the following temporary reservation:

**STAWELL**—The temporary reservations by Orders in Council of 20 June 1905, 26 January 1949 and 6 November 1985 of 26.78 hectares more or less in the Township of Stawell as a site for Public Gardens, Public Recreation and Tourist Camp so far only as the purpose of Public Gardens is concerned—(Rs. 5020).

Dated 2 June 1987

Responsible Minister:

JOAN E. KIRNER

Minister for Conservation, Forests and Lands

E. M. MILLER

Acting Clerk of the Executive Council

*The Constitution Act Amendment Act 1958*

**APPOINTMENT OF RETURNING OFFICER**

The Governor in Council under section 145 of *The Constitution Act Amendment Act 1958*, appoints Douglas John ALLEN as Returning Officer for the Electoral District of Rodney.

Dated: 10 June 1987

Responsible Minister:

ANDREW McCUTCHEON

Minister for Property and Services

E. M. MILLER

Acting Clerk of the Executive Council

*Transport Act 1983*

**AMENDMENT TO THE PROCLAMATION OF OUTER-SUBURBAN TAXI-CAB ZONE AND SPECIFICATION OF LICENSING PROCEDURES**

The Governor in Council under section 143A of the *Transport Act* amends the Order in Council made on 2 June 1987 and published in the *Government Gazette* of 3 June 1987 as follows:

In paragraph (d) (i) of the Order for the expression "26 June 1987" there shall be substituted the expression "3 July 1987".

Dated: 10 June 1987

Responsible Minister:

T. W. ROPER

Minister for Transport

E. M. MILLER

Acting Clerk of the Executive Council

*Transport Act 1983*

**AMENDMENT TO THE PROCLAMATION OF METROPOLITAN TAXI-CAB ZONE AND SPECIFICATION OF LICENSING PROCEDURES**

The Governor in Council under section 143A of the *Transport Act* amends the Order in Council made on 2 June 1987 and published in the *Government Gazette* of 3 June 1987 as follows:

In paragraph (d) (i) of the Order for the expression "26 June 1987" there shall be substituted the expression "3 July 1987".

Dated: 10 June 1987

Responsible Minister:

T. W. ROPER

Minister for Transport

E. M. MILLER

Acting Clerk of the Executive Council



**CITY OF BRUNSWICK**

**Appointment of Prosecuting Officer**

Notice is hereby given that Senior Sergeant Peter William Harvey No. 16543 has been appointed as Prosecuting Officer for the City of Brunswick replacing Senior Sergeant Geoffrey Craig Burrows No. 15587 (transferred).

7400 K. D. WILSON, Town Clerk

**CITY OF RINGWOOD**

**Change of Street Name**

**Erica Crescent**

In accordance with section 535 (4) of the Local Government Act notice is given that the Council of the City of Ringwood at its meeting held on 1 June 1987 resolved to alter the name of a segment of Erica Crescent, shown hatched on the following plan to Erica Court.

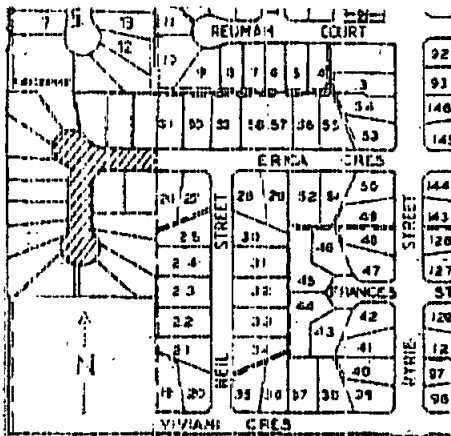

7386 R. B. CATTERALL, Town Clerk

**Form 2.1**

**Town and Country Planning Act 1961  
CITY OF SHEPPARTON PLANNING  
SCHEME 1953**

Notice that a Planning Scheme has been Prepared and is Available for Inspection  
Amendment No. 112, 1987

Notice is hereby given that the Council of the City of Shepparton, in pursuance of its powers

under the *Town and Country Planning Act 1961*, has prepared a Scheme for the purpose of:

Amending the Town Planning Scheme to allow the rezoning of Land at 127 Numurkah Road from Commercial "C" to Residential "C".

Land at 137 Numurkah Road from Commercial "B" to Residential "C" to permit the construction of display homes.

A copy of the Scheme has been deposited at the office, of the Council, Municipal Offices, Welsford Street, Shepparton, and at the office of the Ministry for Planning and Environment (Plan Inspection Section), Ground Floor, The Olderfleet Buildings, 477 Collins Street, Melbourne and will be open for inspection during office hours by any person free of charge. Any persons affected by the Scheme are required to set forth, in writing, any submission they may wish to make, with respect to the Scheme, addressed to the City Manager/Town Clerk, City of Shepparton, P.O. Box 989, Shepparton, 3630, by 10 July 1987, and state whether you wish to be heard in respect of the submission.

I. L. GILBERT

7389 City Manager/Town Clerk

**Form 2:1**

**Town and Country Planning Act 1961  
CITY OF SHEPPARTON PLANNING  
SCHEME 1953**

Notice that a Planning Scheme has been Prepared and is Available for Inspection  
Amendment No. 114, 1987

Notice is hereby given that the Council of the City of Shepparton, in pursuance of its powers under the *Town and Country Planning Act 1961*, has prepared a Scheme for the purpose of:

Amending the Town Planning Scheme to allow the rezoning of land at 127 Fryers Street from Special Use "A" (Churches and Church Schools) to Commercial "A" to allow for commercial usage of the site and to modify the zoning to accord with that of the surrounding area.

A copy of the Scheme has been deposited at the office, of the Council, Municipal Offices, Welsford Street, Shepparton, and at the office of the Ministry for Planning and Environment (Plan Inspection Section), Ground Floor, The Olderfleet Buildings, 477 Collins Street, Melbourne and will be open for inspection during office hours by any person free of charge. Any persons affected by the Scheme are required to set forth, in writing, any submission they may wish to make, with respect to the Scheme, addressed to the City Manager/Town Clerk, City of Shepparton, P.O. Box 989, Shepparton, 3630.

by 10 July 1987, and state whether you wish to be heard in respect of the submission.

I. L. GILBERT  
7460 City Manager/Town Clerk

*Local Government Act 1958*  
CITY OF WANGARATTA

Notice is hereby given, as required by section 656LA of the *Local Government Act 1958* that the Council of the City of Wangaratta intends to borrow certain sums, secured against drainage rates made pursuant to section 656I of that Act.

The borrowings are to be applied to the part-construction cost of an approved Flood Mitigation Scheme as follows:

- Wilson Road area Levee Bank \$20 113
- Parfitt Road area Levee Bank \$174 260

7443 J. W. ELWARD, Town Clerk

TOWN OF BAIRNSDALE

Publication of Resolution of the Council of Road Discontinuance pursuant to Section 528 (2) of the *Local Government Act 1958*

Whereas the Council of the Town of Bairnsdale

1. is of the opinion that the right of way at the rear of 212 Main Street, Bairnsdale which is shown within the thick lines on the plan at the foot hereof is not reasonably required as a road for public use;

2. has consulted with the public statutory corporations referred to in Section 528 (2) (e);

3. has not less than one month before the date of this meeting published a public notice in "The Bairnsdale Advertiser" newspaper and given written notice to the registered proprietors of the land and the owners and occupiers of the land abutting or immediately adjacent to the said road in accordance with Section 528 (2) (a) (iii);

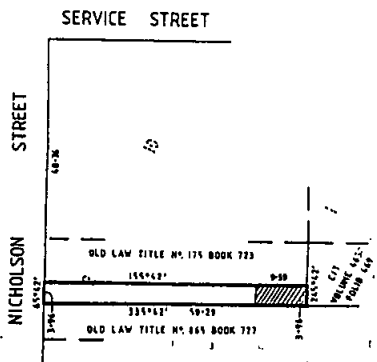

Now the Council does hereby direct—

- (a) that the said road which is shown within the thick lines on the plan herewith shall be discontinued upon publication of this resolution in the *Government Gazette*.
- (b) that notwithstanding such discontinuance the Mitchell Water Board shall continue to have and possess the same right title power authority or interest in or in relation to that portion of the land shown by hatching on the said plan as it had or possessed prior to such discontinuance with respect to or in connection with any drains or pipes laid or erected in or over such land for the purpose of drainage or sewerage;
- (c) that subject to any such right title power authority or interest the land in the said road shall vest in the municipality until it is sold by private treaty.

7404 G. G. McWHINNEY  
Town Clerk

Form 2.1

*Town and Country Planning Act 1961*  
BOROUGH OF SEBASTOPOL PLANNING SCHEME

Notice that a Planing Scheme has been Prepared and is Available for Inspection  
Amendment No. 44

Notice is hereby given that the Council of the Borough of Sebastopol in pursuance of its powers under the *Town and Country Planning Act 1961* has prepared a scheme for the following area:

Land being Crown Allotment 25, section 47, Township of Sebastopol, located at 107 Rubicon Street, Sebastopol. The Planning Scheme proposes to rezone the land from "Residential" to "Commercial B".

A copy of the scheme has been deposited at the Town Hall, 181 Albert Street, Sebastopol, at the Regional Office of the Ministry for Planning and Environment, Corner Mair and Doveton Streets, Ballarat and at the office of the Ministry for Planning and Environment, The Olderfleet Buildings, 477 Collins Street, Melbourne, and will be open for inspection during office hours to any persons free of charge.

Any persons affected by the scheme are required to set forth in writing any submissions they may wish to make with respect to the scheme addressed to the Town Clerk, Borough of Sebastopol, Town Hall, 181 Albert Street, Sebastopol by Monday 6 July 1987 and state whether you wish to be heard in respect of your submission.

7388 P. B. COOK, Town Clerk

**BOROUGH OF KERANG**

**By-Law No. 14**

**Verandah Post By-Law**

Notice is hereby given that in pursuance of the powers conferred by the *Local Government Act 1958* the Council of the Borough of Kerang has made a By-Law numbered 14 for the purposes of amending By-Law No. 4 to give Council discretionary power to grant permission for the erection of buildings with verandahs other than cantilever verandahs.

The resolution for passing this By-Law was agreed to by the Council of the Borough of Kerang on 22 April 1987 and confirmed on 27 May 1987.

A copy of the By-Law is open for inspection free of charge at the office of the Council, 71 Wellington Street, Kerang.

7405 **B. G. O'DWYER**  
Town Clerk

*Local Government Act 1958* (As amended)

**SHIRE OF ARARAT**

**Notice of Intention to Take Land Compulsorily**

The Council of the Shire of Ararat deems it expedient to exercise its powers of taking land compulsorily and in the opinion of the Council such compulsory taking of land is necessary, and desirable notice is hereby given:

1. That the Council of the Shire of Ararat has deemed it expedient to exercise its power of taking compulsorily the land described hereunder for Public Purposes.

2. The said Council has caused to be prepared and has approved maps and other papers showing the general description of the work or undertaking for which the land proposed to be taken is to be used, the description of the land proposed to be so taken and the names of the owners or reputed owners lessees or reputed lessees, mortgagees and occupiers of the said land so far as these names are known to or can be ascertained by the Council.

3. Such maps and other papers have been deposited at the office of the Council, Shire Hall, Barkly Street, Ararat and are open for inspection by all persons interested at all reasonable hours for 40 clear days after the publication of this notice in the *Government Gazette*.

4. The land proposed to be taken is:

All that piece of land being Allotment 8, Township of Lake Bolac, Parish of Parupa, County of Ripon and being the land described in a land purchase dealing dated 19 September 1862.

5. All persons affected by the proposed taking of the said land are required to set forth in writing,

addressed to the Council or the Shire Secretary of the Shire of Ararat within 40 clear days from the publication of this notice in the *Government Gazette*, all objections which they may have to the taking of the said land.

7401 **BARRY J. SERTORI**  
Shire Secretary

**Schedule 1**

**Form 2.1**

*Town and Country Planning Act 1961*  
**SHIRE OF CRANBOURNE (WESTERN PORT) PLANNING SCHEME**

Notice that a Planning Scheme has been Prepared and is Available for Inspection  
Amendment No. 44, 1987

Notice is hereby given that the Shire of Cranbourne in pursuance of its powers under the *Town and Country Planning Act 1961*, has prepared a Scheme:

To rezone Crown Allotment 87A, Parish of Sherwood situated on the south-east corner of North Road and Coolebah Road, Devon Meadows from Extractive Industry to General Farming A.

A copy of the Scheme has been deposited at the Shire Offices, Cranbourne and at the office of the Ministry for Planning and Environment, The Olderfleet Buildings, 477 Collins Street, Melbourne and will be open for inspection during office hours by any person free of charge.

Any person affected by the Scheme are required to set forth in writing any submissions they may wish to make with respect to the Scheme addressed to the Shire Secretary, Shire of Cranbourne, Shire Offices, Cranbourne, by 10 July 1987 and to state whether you wish to be heard in respect of your submissions.

7387 **A. J. HOBAN, Town Planner**

**Form 2.1**

*Town and Country Planning Act 1961*  
**SHIRE OF FLINDERS PLANNING SCHEME**  
1962

Notice that a Planning Scheme has been Prepared and is Available for Inspection  
Amendment No. 220, 1987

Notice is hereby given that the Council of the Shire of Flinders in pursuance of its powers under the *Town and Country Planning Act 1961* has prepared a scheme to amend the Planning Scheme Ordinance to allow 'Medical Consulting Rooms' as a discretionary use in the Bayside Residential 2 Zone.

A copy of the amendment has been deposited at the office of the Shire of Flinders, Boneo Road, Rosebud, and at the office of the Ministry for Planning and Environment, The Olderfleet Buildings, 477 Collins Street, Melbourne, and will be open for inspection during office hours by any person free of charge.

Any persons affected by the amendment are required to set forth in writing any submission they may wish to make with respect to the amendment addressed to The Chief Executive, Shire of Flinders, PO Box 1000, Rosebud 3939 by 15 July 1987 and state whether you wish to be heard in respect of your submission.

Dated 3 June 1987

PETER KRSTIC  
Statutory Planner

7402

SHIRE OF HASTINGS  
Discontinuance of Roads  
Banksia and Somers Sanctuary Estates  
Somers

At its meeting held on 19 May 1987, the Council of the Shire of Hastings, being of the opinion that the parts of various roads within the Banksia and Somers Sanctuary Estates, Somers, identified in the plans hereunder, are not reasonably required as roads for public use, and having complied with the provisions of sections 528 (2) (a) (ii) and (iii) of the *Local Government Act 1958* (as amended), resolved that the roads be discontinued, and upon publication of its resolution in the *Government Gazette*, the land being the roads was to be retained by the Council of the Shire of Hastings for municipal purposes, subject to:

The State Electricity Commission of Victoria continuing to have and possess the same right, title, power, authority or interest in or in relation

to the land being the discontinued part of roads as it had or possessed prior to such discontinuance with respect to the connection of any pipes, wires and other fittings later erected in, on or over such land for electrical reticulation purposes.

THE AREA OF ROAD TO BE CLOSED IS SHOWN HATCHED

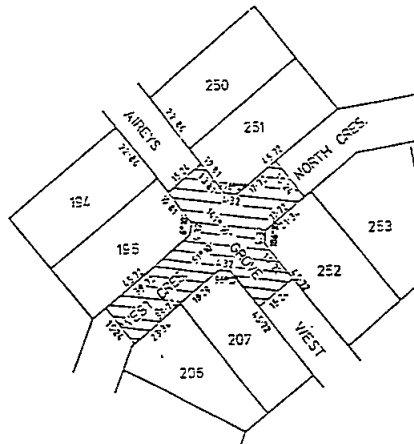

PLAN OF ROAD CLOSURE  
PART OF CROWN ALLOTMENTS 140 & 141  
PARISH OF BITTERN  
COUNTY OF MORNINGTON

THE AREA OF ROAD TO BE CLOSED IS SHOWN HATCHED

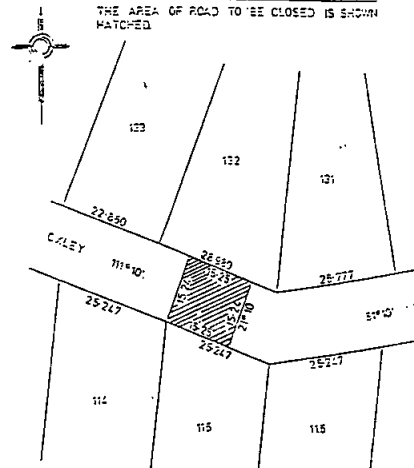

THE AREA OF ROAD TO BE CLOSED IS SHOWN HATCHED

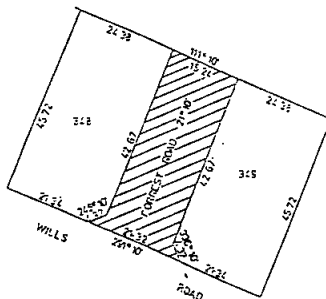





*Town and Country Planning Act 1961*  
**SHIRE OF NEWHAM AND WOODEND  
 PLANNING SCHEME**

Notice that a Shire of Newham and Woodend  
 Planning Scheme Amendment has been  
 Prepared and is Available for Inspection  
 Amendment No. 26

Notice is hereby given that the Shire of  
 Newham and Woodend in pursuance of its  
 powers under the *Town and Country Planning  
 Act 1961* has prepared a Planning Scheme  
 Amendment for the "Service Trades and Light  
 Industrial" zones in Woodend.

A copy of the Amendment has been deposited  
 at the Municipal Offices, 92 High Street,  
 Woodend and at the Office of the Ministry for  
 Planning and Environment, The Olderfleet  
 Buildings, 477 Collins Street, Melbourne, and  
 will be open for inspection during office hours by  
 any person free of charge.

Any persons affected by the Amendment are  
 required to set forth in writing any submission  
 they wish to make with respect to the  
 Amendment addressed to the Shire Secretary,  
 Shire of Newham and Woodend, 92 High Street,  
 Woodend by 15 July 1987, and state whether  
 they wish to be heard in respect of their  
 submission.

7461 DAN DREW, Shire Secretary

*Town and Country Planning Act 1961*  
**SHIRE OF ROCHESTER (ROCHESTER  
 TOWNSHIP) PLANNING SCHEME**

Notice that an Amendment has been Prepared  
 and is Available for Inspection  
 Amendment No. 23

Notice is hereby given that the Council of the  
 Shire of Rochester in pursuance of its powers  
 under the *Town and Country Planning Act 1961*,  
 has prepared an amendment to the Shire of  
 Rochester (Rochester Township) Planning  
 Scheme for the purpose of creating a Rural  
 Residential Zone on the land south of Pascoe  
 Street and between Bonn Road and Cohen Road.

A copy of the scheme has been deposited at  
 the Shire Office, Mackay Street, Rochester, and  
 at the office of the Ministry for Planning and  
 Environment (Plan Inspection Section), Ground  
 Floor, 427 Collins Street, Melbourne, and will be  
 open for inspection during office hours by any  
 person free of charge.

Any persons affected by the scheme are  
 required to set forth in writing any submission  
 they may wish to make with respect to the  
 scheme, addressed to the Shire Secretary, Shire  
 of Rochester, PO Box 121, Rochester, Victoria

3561, by 10 July 1987, and to state whether they  
 wish to be heard in respect of their submission.

7462 K. W. JACKEL, Shire Secretary

Form 2.1

*Town and Country Planning Act 1961*  
**SHIRE OF STAWELL**

Notice that a Planning Scheme has been  
 prepared and is available for Inspection.

**Lake Bellfield Planning Scheme  
 Amendment No. 22**

Notice is hereby given that the Council of the  
 Shire of Stawell in pursuance of its powers under  
 the *Town and Country Planning Act 1961*; has  
 prepared a Scheme for amending the ordinance  
 regarding the definition of "Residential Unit"  
 and allowing such in conjunction with either a  
 Cluster or Strata Subdivision in a Residential  
 Zone.

A copy of the Scheme has been deposited at  
 the Shire of Stawell Municipal Offices, and at the  
 Office of the Ministry for Planning and  
 Environment, the Olderfleet Building, 477  
 Collins Street, Melbourne, and at its Regional  
 Office in Ballarat, and will be open for inspection  
 during Office Hours by any person free of charge.

Any persons effected by the Scheme are  
 required to set forth in writing any submission  
 they wish to make in respect of the Scheme,  
 addressed to the Shire Secretary, Shire of Stawell,  
 Shire Offices, Stawell, Vic., 3380, by 3 July 1987,  
 and state whether they wish to be heard in respect  
 of their submission.

7440 B. J. THOMAS  
 Shire Secretary

Form 2.1

*Town and Country Planning Act 1961*  
**SEYMOUR PLANNING SCHEME**

Notice that a planning scheme has been  
 prepared and is available for inspection

**Amendment No. 103**

Notice is hereby given that the Shire of  
 Seymour in pursuance of its powers under the  
*Town and Country Planning Act, 1961* has  
 prepared a scheme for the following area:

Lot 44, Lodged Plan 2504, Parish of Tallarook,  
 (86 Anzac Avenue, Seymour), for the purpose of  
 re-zoning the land from Residential zone to  
 Commercial Local zone.

A copy of the scheme has been deposited at  
 the office of the Shire of Seymour and at the  
 office of the Department of Planning and  
 Environment (Plan Inspection Section, Ground  
 Floor, Older Fleet Building, 477 Collins Street,

Melbourne), and will be open for inspection during office hours by any person free of charge.

Any persons affected by the scheme are required to set forth in writing any submission they may wish to make with respect to the scheme addressed to The Secretary Shire of Seymour, P.O. Box 117, Seymour 3660 by 10 July 1987 and to state whether they wish to be heard in respect of their submission.

Dated 1 June 1987

PETER L. McCUBBIN  
Planning Officer

7403

#### BALLARAT WATER BOARD

##### General Notice

The abovementioned Water Board having made provision for carrying off the sewage from each and every property which or any part of which is within the Sewerage Area hereinafter described doth hereby declare that on and after 1 July 1987, each and every property which or any part of which is within the said Sewerage Area shall be deemed to be a sewered property within the meaning of the *Sewerage Districts Act* 1958.

##### *Sewerage Area No. 495*

###### City of Ballarat

Commencing at a point on the north corner of No. 609 Tress Street, Township of Ballarat East, Parish of Ballarat, being also a point on the boundary of Sewerage Area Nos. 133 and 391, thence south westerly along the boundary of the said Sewerage Area No. 391 to a point on the boundary of Sewerage Area No. 130 thence south westerly, north westerly and north easterly along the boundary of the said Sewerage Area No. 130 to a point on the boundary of Sewerage Area No. 390 thence generally north easterly and north westerly along the boundary of the said Sewerage Area No. 390 to a point on the boundary of Sewerage Area No. 429 thence north easterly and north westerly along the boundary of the said Sewerage Area No. 429 to a point on the boundary of Sewerage Area No. 72 thence north easterly along the boundary of the said Sewerage Area No. 72 to a point on the boundary of Sewerage Area No. 74 thence south easterly and north easterly along the boundary of the said Sewerage Area No. 74 to a point on the boundary of Sewerage Area No. 72 thence south easterly along the boundary of the said Sewerage Area No. 72 to a point on the boundary of Sewerage Area No. 133 thence south westerly and south easterly along the boundary of the said Sewerage Area No. 133 to the point of commencement.

##### *Sewerage Area No. 496*

All that piece of land contained in Crown Allotment 9, Section 51, Township of Ballarat East, Parish of Ballarat.

##### *Sewerage Area No. 497*

Commencing at a point on the north east corner of Lot 1, L.P. 50077, Township of Ballarat East, Parish of Ballarat, also being a point on the boundary of Sewerage Area No. 371 thence easterly along the south building line of Duggan Street to and across Leerama Court continuing along the said building line to the north east corner of Lot 1, L.P. 205120, thence southerly along the eastern boundaries of the said Lot 1 and Lots 14-16 inclusive, L.P. 205120, thence westerly along the southern boundaries of the said Lot 16 and Lots 17-22 inclusive, L.P. 205120, thence northerly to the north west corner of the said Lot 22 thence westerly along the southern boundary of Lot 23, L.P. 205120, continuing along the southern boundaries of Nos. 110-106 inclusive Duggan Street and No. 102 Duggan Street to a point on the boundary of Sewerage Area No. 371 thence northerly along the boundary of the said Sewerage Area No. 371 to the point of commencement.

##### *Sewerage Area No. 498*

Commencing at the south west corner of Wilson and Otway Streets, Township of Ballarat East, Parish of Ballarat, being also a point on the boundary of Sewerage Area No. 326 thence generally southerly along the said Sewerage Area No. 326 to the south west corner of Otway and Glendenning Streets being also a point on the boundary of Sewerage Area No. 206 thence north westerly along the boundary of the said Sewerage Area No. 206 to the north west corner of No. 203 Clayton Street thence north westerly along the north west building line of Glendenning Street to the south east corner of Lot 2, L.P. 144139, thence south westerly along the south east boundary of the said Lot 2 continuing by a line across Larter Street to a point on the boundary of Sewerage Area No. 157 thence north westerly and easterly along the boundary of the said Sewerage Area No. 157 to a point approximately 45 metres east of the north east corner of Wilson and Larter Streets thence south easterly to the south east corner of Glendenning and Wilson Streets continuing generally south easterly to the south west corner of Crown Allotment 21, Section 84, thence north easterly to the north westerly corner of the said Crown Allotment 21 thence easterly along the south building line of Wilson Street to the point of commencement.

*Sewerage Area No. 499*

Commencing at the south east corner of Morres and Rice Streets, Township of Ballarat East, Parish of Ballarat, being also a point on the boundary of Sewerage Area No. 84 thence by a line across Morres Street to the north east corner of Morres and Rice Streets continuing north westerly along the north east building line of Rice Street to the north west corner of Lot 5, L.P. 204661, thence north easterly along the north west boundary of the said Lot 5 and Lot 2, L.P. 204661, thence easterly along the northern boundary of the said Lot 2 and Lot 1, L.P. 204661, thence southerly along the east boundary of the said Lot 1 and across Morres Street to a point on the boundary of Sewerage Area No. 84 thence continuing south westerly along the said Sewerage Area No. 84 to the point of commencement.

*Sewerage Area No. 500*

Commencing at a point on the north building line of Wilson Street, Township of Ballarat East, Parish of Ballarat, approximately 82.3 metres west of Kline Street being also a point on the boundary of Sewerage Area No. 280 thence southerly along the boundary of the said Sewerage Area No. 280 to a point on the south building line of Wilson Street thence westerly along the said south building line to a point on the boundary of Sewerage Area No. 461 thence north easterly, northerly and easterly along the boundary of the said Sewerage Area No. 461 to a point on the boundary of Sewerage Area No. 255 continuing easterly along the boundary of the said Sewerage Area No. 255 to the north east corner of Lot 5, L.P. 206891, being also a point on the boundary of Sewerage Area No. 280 thence south easterly along the boundary of the said Sewerage Area No. 280 to the point of commencement.

*Sewerage Area No. 501*

Commencing at a point on the south east corner of Lot 10, L.P. 206890, Township of Ballarat East, Parish of Ballarat, being also the boundary of Sewerage Area No. 461 thence southerly along the boundary of the said Sewerage Area No. 461 to the south building line of Wilson Street thence westerly along the said south building line across Rodier Street continuing westerly to the boundary of Sewerage Area No. 326 thence northerly along the boundary of the said Sewerage Area No. 326 to a point being the north west corner of Lot 2, L.P. 2042331, thence easterly along the north boundary of the said Lot 2 to a point on the west building line of Rodier Street thence northerly along the said west building line to a point on the boundary of Sewerage Area No. 462 thence easterly along the

boundary of the said Sewerage Area No. 462 to a point on the boundary of Sewerage Area No. 232 thence southerly along the said boundary of Sewerage Area No. 232 to a point on the boundary of Sewerage Area No. 461 thence southerly, easterly, southerly and westerly along the boundary of the said Sewerage Area No. 461 to the point of commencement.

Further particulars regarding the streets or part of streets in which sewers have been laid may be ascertained at the Board's Office.

By Order of the said Water Board

M. E. J. FOO, Chairman  
7444 P. A. POLLARD, Secretary

## BALLARAT WATER BOARD

## General Notice

The abovementioned Water Board having made provision for carrying of the sewage from each and every property which or any part of which is within the Sewerage Area hereinafter described doth hereby declare that on and after 1 July 1987, each and every property which or any part of which is within the said Sewerage Area shall be deemed to be a sewered property within the meaning of the *Sewerage Districts Act* 1985.

*Sewerage Area No. 506*

## Shire of Bungaree

The boundaries of all those pieces of land comprising Crown Allotment 5A and Crown Allotment 7, Section 21, Township of Ballarat North, Parish of Ballarat, and the section of Simpson Street which abuts the above allotments,

*Sewerage Area No. 507*

## Shire of Bungaree

The boundaries of all those pieces of land comprising Lot Nos. 1-4 inclusive and Lot Nos. 15-17 inclusive on Lodged Plan of Subdivision No. 202906 such allotments having an abuttal to Sherrard Street, Lot Nos. 5-14 inclusive on Lodged Plan of Subdivision No. 202906 such allotments having an abuttal to Kenvarra Court, Lot Nos. 18-20 inclusive on Lodged Plan of Subdivision No. 202906 such allotments having an abuttal to Maddern Street and those sections of Sherrard, Maddern and Howitt Streets and Kenvarra Court which abut the above allotments.

Further particulars regarding the streets or parts of streets in which sewers have been laid may be ascertained at the Board's Office.

By Order of the said Water Board.

M. E. J. FOO, Chairman  
7449 P. A. POLLARD, Secretary

**BALLARAT WATER BOARD**

Pursuant to section 119 (2) of the *Sewerage Districts Act 1958* (No. 6368) notice is hereby given of the intention to construct a sewer for property situated in the vicinity of the following streets:

*City of Ballarat*

Joseph Street  
Wainwright Street  
Heales Street  
Canterbury Street

*Shire of Buninyong*

Whitehorse Road

more particularly as shown on plans which are open for inspection at this Office between the hours of 8.45 a.m. and 4.30 p.m., Monday to Friday, inclusive.

7450 P. A. POLLARD, Secretary

hours of 8.10 a.m. and 5.00 p.m. from Monday to Friday (public holidays excepted) by the owners or occupiers of land or premises within the Drainage Area.

7439 R. A. JORDAN, Secretary

**ACT 797 APPLICATION**

If within one calendar month from publication of this advertisement no proceedings be taken by any of the persons in whose name the consent is given, application under sections 6, 7 and 8 of the *Trusts Corporation Act 1884* will be made for the transfer of the land herein described to The Church of England Trusts Corporation for the Diocese of Melbourne.

*Description of Land*

All that piece or parcel of land situate lying and being in the Parish of Jika Jika in the County of Bourke in the Colony of Victoria being part of Lots Nos. 337, 338, 339 and 340 in the Plan of Subdivision by The Reverend Joseph Docker of portions Nos. 21 and 22 of the said Parish commencing at a point distant 278 feet west from the western boundary line of the Government Road bounding the said portion 21 on the east and 70 feet south from the northern boundary line of the said Portion 21 bounded on the east by a line bearing south 43 feet and dividing the said Lot 337 from the Richmond Church Reserve on the south by Richmond Terrace bearing west at right angles to the lastmentioned line 104 feet on the west by a line at right angles to Richmond Terrace aforesaid bearing north 43 feet and dividing the said piece of land from a way 30 feet wide reserved out of the said Lot 340 and on the north by a line parallel to Richmond Terrace aforesaid bearing east 104 feet to the commencing point which piece of land is delineated on the plan drawn in the margin of the Conveyance and is thereon coloured red together with full free and uninterrupted use and enjoyment to the transferees their heirs and assigns and their agents, tenants, servants, friends and others at all times forever thereafter and for all purposes with or without horses, cattle, carts and carriages in common with all others entitled thereto to pass and re-pass in, through, over and along the aforesaid way bounding the said land in the west and in, through, over and along all other roads and ways reserved out of the said Portions 21 and 22 and over which Daniel Stodhart Campbell a predecessor in title of the present proprietors had a disposing power.

7438

**GEELONG AND DISTRICT WATER BOARD**

Pursuant to section 60 of the *Geelong Waterworks and Sewerage Act 1958* (No. 6263) the Board has prepared plans to indicate the particulars of sewers and underground works, the construction of which the Board intends to begin at a date not less than one month after publication of the notices, in or adjacent to the following locality within the Drainage Area:

Hoylake Avenue and Carnarvan Avenue, Jan Juc, Shire of Barrabool

Notice is hereby given that the plans indicated are open for public inspection at the Board's Offices, 51-67 Ryrie Street, Geelong between the hours of 8.10 a.m. and 5.00 p.m. from Monday to Friday (public holidays excepted) by the owners or occupiers of land or premises within the Drainage Area.

7390 R. A. JORDAN, Secretary

**GEELONG AND DISTRICT WATER BOARD**

Pursuant to section 60 of the *Geelong Waterworks and Sewerage Act 1958* (No. 6263) the Board has prepared plans to indicate the particulars of sewers and underground works, the construction of which the Board intends to begin at a date not less than one month after publication of the notices, in or adjacent to the following locality within the Drainage Area:

Marlin Drive/Halibut Avenue/Abalone Court, Collendina, Shire of Bellarine

Notice is hereby given that the plans indicated are open for public inspection at the Board's Offices, 51-67 Ryrie Street, Geelong between the

**BALLARAT WATER BOARD****General Notice**

The abovementioned Water Board having made provision for carrying off the sewage from each and every property which or any part of which is within the Sewerage Area hereinafter described doth hereby declare that on and after 1 July 1987, each and every property which or any part of which is within the said Sewerage Area shall be deemed to be a sewerer property within the meaning of the *Sewerage Districts Act* 1985.

*Sewerage Area No. 502*

## Shire of Buninyong

Commencing at a point on the east building line of Vincent Drive being also the most westerly angle of Lot 1, L.P. 204013, Parish of Ballarat, thence easterly along the north west boundaries of the said Lots 1-8 inclusive, L.P. 204013, thence south easterly along the boundary of the said Lot 8 to and across a right-of-way to the north west corner of Lot 9, L.P. 204013, thence south easterly along the north eastern boundaries of the said Lots 9-13 inclusive, L.P. 204013, thence easterly along the northern boundaries of Lots 14-16 inclusive, L.P. 204013, thence southerly along the east boundary of the said Lot 16 to and across Wattle-tree Drive to the north east corner of Lot 17, L.P. 204013, continuing southerly along the eastern boundary of the said Lot 17 to the most easterly angle of Lot 26, L.P. 204013, thence south westerly along the southern boundary of the said Lot 26 to and across a right-of-way to the most easterly angle of Lot 27, L.P. 204013, thence south westerly and westerly along the boundaries of the said Lots 27 and 28, L.P. 204013, to the south east corner of Lot 42, L.P. 204013, thence south westerly along the south east boundary of the said Lot 42 to and across a right-of-way to the most easterly angle of Lot 43, L.P. 204013, thence south westerly along the south east boundaries of the said Lots 43 and 44, L.P. 204013, continuing by a line across a reserve to a point on the north east building line of Vincent Drive thence north westerly along the north east building line of the said Vincent Drive to the point of commencement.

Further particulars regarding the streets or part of streets in which sewers have been laid may be ascertained at the Board's Office.

By Order of the said Water Board.

7445 M. E. J. FOO, Chairman  
P. A. POLLARD, Secretary

**BALLARAT WATER BOARD****General Notice**

The abovementioned Water Board having made provision for carrying off the sewage from each and every property which or any part of which is within the Sewerage Area hereinafter described doth hereby declare that on and after 1 July 1987, each and every property which or any part of which is within the said Sewerage Area shall be deemed to be a sewerer property within the meaning of the *Sewerage Districts Act* 1958.

*Sewerage Area No. 503*

## Shire of Ballarat

All that piece of land contained in Crown Allotment 9, Section 3, Parish of Dowling Forest.

Further particulars regarding the streets or part of streets in which sewers have been laid may be ascertained at the Board's Office.

By Order of the said Water Board.

7446 M. E. J. FOO, Chairman  
P. A. POLLARD, Secretary

**BALLARAT WATER BOARD****General Notice**

The abovementioned Water Board having made provision for carrying of the sewage from each and every property which or any part of which is within the Sewerage Area hereinafter described doth hereby declare that on and after 1 July 1987, each and every property which or any part of which is within the said Sewerage Area shall be deemed to be a sewerer property within the meaning of the *Sewerage Districts Act* 1958.

*Sewerage Area No. 504*

## Shire of Grenville

The boundaries of all those pieces of land comprising Lot 50 on Lodged Plan of Subdivision No. 203476 such allotment having an abuttal to Glenelg Highway, Lot Nos. 1-6 inclusive and 39-41 inclusive on Lodged Plan of Subdivision No. 203477 such allotments having an abuttal to Panorama Drive, Lot Nos. 7-10 inclusive on Lodged Plan No. 203477 such allotments having an abuttal to Georgia Crescent, Lot Nos. 42-48 inclusive on Lodged Plan No. 203477 such allotments having an abuttal to Parkside Road and those sections of Panorama Drive, Georgia Crescent and Parkside Road which abut the above pieces of land.

Further particulars regarding the streets or parts of streets in which sewers have been laid may be ascertained at the Board's Office.

By Order of the said Water Board.

7447 M. E. J. FOO, Chairman  
P. A. POLLARD, Secretary

**BALLARAT WATER BOARD****General Notice**

The abovementioned Water Board having made provision for carrying of the sewage from each and every property which or any part of which is within the Sewerage Area hereinafter described doth hereby declare that on and after 1 July 1987, each and every property which or any part of which is within the said Sewerage Area shall be deemed to be a seweraged property within the meaning of the *Sewerage Districts Act 1958*.

*Sewerage Area No. 505***Borough of Sebastopol**

The boundaries of all those pieces of land comprising Lot Nos. 1-4 inclusive on Lodged Plan of Subdivision No. 206099v such allotments having an abuttal to Queen Street, Lot Nos. 5-9 inclusive on Lodged Plan of Subdivision No. 206099v such allotments having an abuttal to Spencer Street, Lot No. 10 on Lodged Plan of Subdivision No. 206099v such allotment having an abuttal to Morgan and Spencer Streets and that section of Spencer Street which abuts Lots 5-9 inclusive and Lot 10 of the said Lodged Plan.

Further particulars regarding the streets or parts of streets in which sewers have been laid may be ascertained at the Board's Office.

By Order of the said Water Board.

M. E. J. FOO, Chairman

7448

P. A. POLLARD, Secretary

**NOTICE OF DISSOLUTION OF PARTNERSHIP**

Notice is hereby given that the partnership between Marinus Marius Van Dreumel, Jennifer Anne Van Dreumel, Andrew Gerardus Van Dreumel and Gillian Suzanne Van Dreumel carrying on a service station business at 168 Torquay Road, Grovedale under the name "Caltex Service Centre Grovedale" has been dissolved as from 18 May 1987. The business will continue to be carried on by Marinus Marius Van Dreumel and Jennifer Anne Van Dreumel.

LAMB & CASSIDY, solicitors, of 159 Yarra Street, Geelong 7406

**NOTICE OF DISSOLUTION**

Notice is hereby given that the partnership heretofore subsisting between Diamanta Fountoulakis and Helen Magelaki carrying on the business of beauticians, operating a hair care salon and the retail sale of cosmetics and hair care products under the style or firm name "Body Works" from premises at Shop 8, 189 Toorak Road, South Yarra, Victoria has been dissolved

as from 6 December 1986 so far as concerns Diamanta Fountoulakis.

Dated 2 June 1987

7407

**DIAMANTA FOUNTOLAKIS****NOTICE OF DISSOLUTION OF PARTNERSHIP**

Notice is hereby given that the partnership hitherto subsisting between Graeme Edgar Stephens of Flat 1/19 Polwarth Crescent Belmont in the State of Victoria of the one part and Shirley Doreen Stephens of 38 Hereford Drive Belmont in the said State of the other part carrying on the business of "G. & S. Car Sales" has been dissolved as and from 30 June 1986. The said business shall be continued by the continuing partner Graeme Edgar Stephens.

Dated 22 May 1987

GRAEME EDGAR STEPHENS, SHIRLEY DOREEN STEPHENS

PHILLIP CONSIDINE & CO., solicitors, 40 Myers Street, Geelong 7424

**NOTICE OF DISSOLUTION OF PARTNERSHIP**

Notice is hereby given that the partnership heretofore subsisting between Chere Marie Goodingham and Arthur William Tierney carrying on business as licensed Hotelkeepers in respect of the Union Hotel, 171 High Street, Heathcote under the firm name of "C. N. Goodingham and A. W. Tierney" has been dissolved as and from 31 May 1987.

Dated 25 May 1987

ARTHUR WILLIAM TIERNEY; CHERE MARIE GOODINGHAM 7425

**NOTICE OF DISSOLUTION OF PARTNERSHIP**

Notice is hereby given that the partnership between Robert Charles Neely and John Neely, carrying on a holiday park business at Settlement Road, Cowes under the name "Seaview Holiday Park" has been dissolved from 19 May 1987. The business will continue to be carried on by John Neely and Fay Lorraine Neely.

DAVID BULLARD, solicitor of 316 Queen Street, Melbourne 7463

**NOTICE OF DISSOLUTION OF  
PARTNERSHIP**

Notice is hereby given that the partnership heretofore subsisting between Ronald Leslie Peel of 346 Albert Road, South Melbourne and Martin James Humphris of 280 Park Street, South Melbourne carrying on a business as mixed grocer and sandwich bar at 280 Park Street, South Melbourne under the style or firm of the "Gourmet Grocer" has been dissolved by mutual consent as from 1 January 1987.

Dated 2 May 1987

7442

- (i) laying before it an account showing how the winding up has been conducted and the property of the Society disposed of and giving any explanations thereof; and
- (ii) passing a resolution that the books and papers of the said Society and of the Liquidator relevant to the affairs of the Society may be destroyed after a period of twelve months from the date of the meeting.

Dated at Coburg 4 June 1987

7453

D. B. CHALMERS, Liquidator

**NOTICE THAT A MEMBERS' WINDING  
UP RESOLUTION PASSED**

Notice of hereby given in accordance with section 392 of the *Companies Act* 1981, that at a General Meeting of Molinaro Bros. Pty Ltd duly convened and held on 3 June 1987, the following special resolution was duly passed:

That the Company be wound up voluntarily.

MARIO MOLINARO

7408

Director

**COBURG No. 8 CO-OPERATIVE HOUSING  
SOCIETY LIMITED**

(In Liquidation)

Take notice that the affairs of the above-named Society are now fully wound up and that in pursuance of section 411 of the *Companies (Victoria) Code* and of the *Co-operative Housing Societies Act* 1958, a General Meeting of the Society will be held at 131 Bell Street, Coburg on 24 June 1987 at 2.30 p.m. for the purposes of—

- (i) laying before it an account showing the winding up has been conducted and the property of the Society disposed of and giving any explanations thereof; and
- (ii) passing a resolution that the books and papers of the said Society and of the Liquidator relevant to the affairs of the Society may be destroyed after a period of twelve months from the date of the meeting.

Dated at Coburg 4 June 1987

7454

D. B. CHALMERS, Liquidator

**NOTICE THAT A MEMBERS' WINDING  
UP RESOLUTION PASSED**

Notice is hereby given in accordance with section 392 of the *Companies Act* 1981, that a General Meeting of Haca Pty Ltd duly convened and held on 4 June 1987, the following special resolution was duly passed:

That the Company be wound up voluntarily.

7451

W. R. O. JEFFREYS, Liquidator

**NOTICE THAT A MEMBERS' WINDING  
UP RESOLUTION PASSED**

Notice is hereby given in accordance with section 392 of the *Companies Act* 1981, that a General Meeting of Lube Mobile (Aust) Pty Ltd duly convened and held on 4 June 1987, the following special resolution was duly passed:

That the Company be wound up voluntarily.

7452

GEOFFREY J. MOXEY, Director

**TRADVICE PTY LTD**

(In Voluntary Liquidation)

Notice of Final Meeting

Notice is hereby given pursuant to section 411 of the *Companies (Victoria) Code* that a final meeting of the members of Tradvice Pty Ltd (In Voluntary Liquidation) will be held at the registered office of the company, 19 Iona Avenue, Toorak on Friday, 10 July 1987 at 11 a.m. for the purpose of having an account laid before them showing how the winding up of the company has been conducted and the property of the company disposed of, and of hearing any explanation that may be given by the Liquidator.

Dated 5 June 1987

7455

J. P. NIEUWENHUYSEN

Liquidator

**CAMPBELLFIELD No. 1 CO-OPERATIVE  
HOUSING SOCIETY LIMITED**

(In Liquidation)

Take notice that the affairs of the above-named Society are now fully wound up and that in pursuance of section 411 of the *Companies (Victoria) Code* and of the *Co-operative Housing Societies Act* 1958, a General Meeting of the Society will be held at 131 Bell Street, Coburg on 24 June 1987 at 2.45 p.m. for the purposes of—



Companies (Victoria) Code  
N. R. PARKER ENTERPRISES PTY LTD  
In Voluntary Liquidation  
Notice Convening Final Meeting of Members  
Pursuant to Section 411

Notice is hereby given in pursuance of section 411 of the Companies (Victoria) Code that a General Meeting of Members of the abovenamed Company will be held on 9 July 1987 at 10 a.m. at 19A Hanover Street, Oakleigh for the purpose of having an account laid before them showing the manner in which the winding up has been conducted and the property of the Company disposed of and hearing any explanation that may be given by the Liquidators.

Dated 5 June 1987

7456

W. J. OKEY, Liquidator

Companies Act 1961

HATTWELL HOLDINGS PTY LTD  
Members Voluntary Liquidation

Notice is hereby given, in pursuance of section 411 of the Companies (Victoria) Code that a General Meeting of Members of the abovenamed company will be held at the offices of E. P. Taylor & Co., 220 Chesterville Road, Moorabbin on 5 July 1987 at 9.30 a.m. for the purpose of having the liquidator's accounts laid before them showing the manner in which the winding up has been conducted and the property of the company disposed of and hearing of any explanations that may be given by the Liquidator.

Dated 3 June 1987

7464

R. L. MALE, Liquidator

Companies (Victoria) Code, Section 392 (2)  
PARK EAST PROPRIETARY LIMITED

Notice is hereby given that at a general meeting of the members of the abovenamed Company held on 2 June 1987, it was resolved that the Company would be wound up voluntarily and that Mr Eric Harry Shallcross of Suite 6, 145 Canterbury Road, Toorak, be appointed liquidator.

Notice is also given that after twenty one days from this date I shall proceed to distribute the assets of the Company. Any creditors having any claims against the Company should furnish particulars of same by that date, otherwise I shall proceed to distribute assets without regard to their claim.

Dated 2 June 1987

7409

E. H. SHALLCROSS  
Liquidator

Companies (Victoria) Code, Section 392 (2)  
PARK INN PROPRIETARY LIMITED

Notice is hereby given that at a general meeting of the members of the abovenamed Company held on 2 June 1987, it was resolved that the Company would be wound up voluntarily and that Mr Eric Harry Shallcross of Suite 6, 145 Canterbury Road, Toorak, be appointed liquidator.

Notice is also given that after twenty one days from this date I shall proceed to distribute the assets of the Company. Any creditors having any claims against the Company should furnish particulars of same by that date, otherwise I shall proceed to distribute assets without regard to their claim.

Dated 2 June 1987

7410

E. H. SHALLCROSS  
Liquidator

Companies (Victoria) Code, Section 392 (2)  
LORAYAN INVESTMENTS PROPRIETARY  
LIMITED

Notice is hereby given that at a general meeting of the members of the abovenamed Company held on 2 June 1987, it was resolved that the Company would be wound up voluntarily and that Mr Eric Harry Shallcross of Suite 6, 145 Canterbury Road, Toorak, be appointed liquidator.

Notice is also given that after twenty one days from this date I shall proceed to distribute the assets of the Company. Any creditors having any claims against the Company should furnish particulars of same by that date, otherwise I shall proceed to distribute assets without regard to their claim.

Dated 2 June 1987

7411

E. H. SHALLCROSS  
Liquidator

In the Supreme Court of Victoria between—1987  
No. Co. 309—In the Matter of the Companies (Victoria) Code; and in the matter of Russell Gem Pty. Ltd.—Advertisement of Application for Winding Up

Notice is hereby given that an Application for winding up of the abovementioned company by the Supreme Court of Victoria was on 13 May 1987 filed by Filament Extruders Pty. Ltd. The application is to be heard before the Court in the 7th Court, Law Courts, Lonsdale Street, Melbourne at 10.30 a.m. on 1 July 1987.

The Liquidator whose appointment is sought is Peter Robert Vince of 500 Bourke Street, Melbourne.

Any creditor or contributory of the company desiring to support or oppose the making of an order on the application may appear at the time of hearing by himself or his Counsel for that purpose. A copy of the application will be furnished by the undersigned to any creditor or contributory of the company requiring it on payment of the regulated charge.

The Applicant's address is Playford Street, Stawell, Victoria, 3380.

The Applicant's Solicitor is Messrs. Home Wilkinson & Lowry of 80 Collins Street, Melbourne.

HOME WILKINSON & LOWRY, solicitors for the applicant

Note: Any person who intends to appear on the hearing of the application must serve on or send by post to the abovenamed solicitors notice in writing of his intention so to do. The notice must state the name and address of the person or, if a firm, the name and address of the firm, and must be signed by a person or firm, or his or their solicitor (if any), and must be served or, if posted, must be sent by post in sufficient time to be received not later than 4 p.m. of 30 June 1987.

7391

#### LISROCK PROPRIETARY LIMITED

(in Voluntary Liquidation).

At an Extraordinary General Meeting of shareholders of the company held at the offices of B.G. Cupit & Co., 3rd Floor, Corporation Centre, 123-129 Clarence Street, Sydney, NSW on 28 May 1987 it was resolved that the company be placed into members' voluntary liquidation and that Mr D. J. Cupit, care of B. G. Cupit & Co., 123-129 Clarence Street, Sydney be appointed liquidator of the company.

Dated 28 May 1987

7392

D. J. Cupit, Liquidator

#### FEELFIT INVESTMENTS PTY. LTD.

Members Voluntary Winding Up

Please take notice that on Tuesday, 30 June 1987 at 135 McCrae Street, Bendigo at 8.30 a.m. the Liquidator of the Company Doctor John Edward Gault proposes to lay before this final meeting a copy of his accounts showing monies received and moneys disposed and give explanations.

7393

Creditors, next of kin and others having claims in respect of the estate of Olive Maria May Smith, late of Unit 4, 121 Centre Dandenong Road, Dingley in the State of Victoria, widow, deceased, who died on 25 March 1987 are required to send particulars of their claims to the executor care of the undermentioned solicitors by 10 August 1987 after which date she will distribute the assets having regard only to the claims of which notice has been received.

LYTTLETON & GILLARD, solicitors, 51 Marcus Road, Dingley 7394

GEOFFREY ALAN WEST (deceased), late of 53 Lockie Crescent, Tivoli Heights, Queensland, died on 10 April 1987

Any persons claiming to be dependant upon the deceased are requested to send particulars of their claims to "Life Claims Department, Australian Eagle Ins. Co. Ltd., GPO Box 1883R, Melbourne 3001", within two months of the date of this notice, after which date the deceased's entitlement will be distributed in accordance with the provisions of the Eagle Retirement Fund Trust Deed, having regard only to the claims which have been notified.

7395

Creditors, next of kin and others having claims in respect of the estate of Anne Elizabeth Butler, late of Flat 7, 34 Park Street, St Kilda, architect, deceased, intestate, who died on 27 January 1987 and Letters of Administration of whose estate were granted by the Supreme Court of Victoria on 22 May 1987 to Alan Thomas Butler of 14 Borsa Crescent, Hepburn Springs are to send particulars of their claims to the said administrator care of the below mentioned solicitors by 18 August 1987 after which date he will distribute the assets of the deceased having regard only to the claims of which he then has notice.

LITTLETON, HACKFORD & MALKIN, solicitors, Law Chambers, 115-119 Hotham Street, Traralgon 7396

GRAHAM JOHN BRUMBY (deceased), late of 19 Nuttall Street, Bulimba, Qld, died on 22 April 1987

Any persons claiming to be dependant upon the deceased are requested to send particulars of their claims to "Life Claims Department, Australian Eagle Ins. Co. Ltd., G.P.O. Box 1883R, Melbourne 3001", within two months of the date of this notice, after which date the deceased's entitlement will be distributed in accordance with the provisions of the Eagle Superannuation Trust, Trust Deed, having regard only to the claims which have been notified.

7412

Creditors, next of kin and others having claims against the estate of Reginald Francis Dyball formerly of Flat 1A/21 The Upper Esplanade, St. Kilda in the State of Victoria, but late of 5 Lorac Avenue, Brighton in the said State, furniture manufacturer are required by the executors of the Will of the deceased to send particulars of the claims to their solicitors Messrs G. W. P. Aarons & Co. of 262 Queen Street, Melbourne on or before 16 August 1987 after which date the executors will distribute the assets having regard only to the claims of which they will then have had notice. 7413

IVY MARJORIE FITZGIBBON, late of Jamieson Road, Mansfield, widow, deceased

Creditors, next of kin and others having claims in respect of the deceased (who died on 17 June 1986) are required by his Trustee Thomas Michael Rodney Ryan of 9 High Street Mansfield solicitor to send particulars to him care of the undermentioned firm of solicitors by 29 July 1987 after which date the Trustee may convey and distribute the assets having regard only to the claims of which he then has notice.

MAL. RYAN, JACKSON & GLEN, 9 High Street, Mansfield, solicitors for the trustee 7414

GORDON MAXWELL GARDINER, late of 23 Werder Street, Box Hill North, in the State of Victoria, gentleman, deceased

Creditors, next of kin and others having claims in respect of the estate of the deceased who died on 10 January 1987 are required by the executors to whom Probate has been granted namely Frederick James Gardiner of 65 The Ridge, Mt. Eliza and Rex Gardiner of 13 Ferris Avenue, Box Hill both in the said State to send particulars to them care of their solicitors, Klooger Forbes & Co., of 1341 Toorak Road, Burwood in the said State by 21 August 1987 after which date the said executors may convey or distribute the assets having regard only to the claims of which they then have notice. 7415

Creditors, next of kin and others having claims in respect of the estate of Patrick Folliot Cawcutt, late of 8 Avondale Road, Morwell, who died on 20 December 1986 and probate of whose Will was granted by the Supreme Court of Victoria on 22 May 1987, to Irene Mavis Cawcutt of 8 Avondale Road, Morwell are to send particulars of their claims to the said executrix by 18 August 1987 after which date she will distribute the assets of the deceased having regard only to the claims of which she then has notice.

LITTLETON, HACKFORD & MALKIN, solicitors, Law Chambers, 115-119, Hotham Street, Traralgon 7398

JAMES CARSTAIRS LOWSON, late of 386 Wattletree Road, East Malvern, engineer, deceased

Creditors, next of kin and others having claims in respect of the estate of the abovenamed deceased (who died on 16 February 1987) are required to send particulars of their claims to the executors Cecilia Lowson of 386 Wattletree Road, East Malvern, widow, John James Lowson of 25 Thackeray Street, Elwood, subcontractor, Ann Grady of 7 Ralton Avenue, Glen Waverley, married woman and Robert Russell Aitken of 114 William Street, Melbourne, solicitor care of the undermentioned solicitors by 25 August 1987 after which date they may convey or distribute the assets having regard only to the claims of which they then have notice.

AITKEN WALKER & STRACHAN, solicitors, 114 William Street, Melbourne 7457

DOROTHY MARY BARRY, formerly of "Alcheringa", Stewart Street, Swan Hill, but late of Robinvale, in the State of Victoria, widow, deceased

Creditors, next of kin and other persons having claims against the estate of the said deceased who died on 27 March 1987 are required to send particulars of same to the Executors John James Barry and Marie Therese Pragt in care of the undersigned on or before 15 August 1987 after which date they will distribute the assets having regard only to the claims of which they have notice.

DWYER, BENNETT & MAHON, barristers and solicitors, 194-208 Beveridge Street, Swan Hill 7458

MARJORY BROWN, late of 116 Thornhill Park Streetly, Sutton, Coldfields, West Midlands, England, banker, deceased, who died on 3 January 1986

Creditors, next of kin and others having claims in respect of the estate of the deceased are required by the legal personal representative of her Will and Estate, Bryan David Connor of 20 Bond Street, Sydney, New South Wales—Trust Manager to send particulars thereof to him care of New Zealand Insurance Co. Ltd., 6th Floor, 20 Bond Street, Sydney, New South Wales before 17 August 1987 after which date he may distribute the assets of the deceased having regard only to the claims of which he then has notice.

FREDERICK OWEN & ASSOCIATES, solicitors, 450 Little Collins Street, Melbourne 7459

THELMA FLORENCE KINGSTON, late of 173 Prospect Hill Road, Canterbury, widow, deceased

Creditors, next of kin and others having claims in respect of the estate of the deceased who died on 21 February 1987 are required by the personal representatives James Crawford Stewart and John Bruce McNeil to send particulars to them care of the undermentioned solicitors by 1 September 1987 after which date the said personal representatives may convey or distribute the assets having regard only to the claims of which they then have notice.

Dated 4 June 1987

YOUNG HUBBARD & CO., solicitors, 825 Burke Road, Camberwell 7465

Creditors, next of kin and others having claims in respect of the estate of Alfred Oscar Kanavan, late of 6 Pollock Avenue, Traralgon, fire officer, deceased, who died on 22 February 1987, probate of whose Will was granted by the Supreme Court of Victoria on 19 May 1987 to Eileen Madge Kanavan of 6 Pollock Avenue, Traralgon, home duties, are to send particulars of their claims to the said executrix by 18 August 1987, after which date she will distribute the assets of the deceased having regard only to the claims of which she then has notice.

LITTLETON, HACKFORD & MALKIN, solicitors, Law Chambers, 115-119 Hotham Street, Traralgon 7397

Creditors, next of kin and others having claims in respect of the estate of John Charles Brown, late of 9 James Parade, Traralgon, retired gentleman, deceased, who died on 14 January 1987 and probate of whose Will was granted by the Supreme Court of Victoria on 21 May 1987, to Mary Fleming Brown of 9 James Parade, Traralgon, home duties, are to send particulars of their claims to the said executrix by 18 August 1987 after which date she will distribute the assets of the deceased having regard only to the claims of which she then has notice.

LITTLETON, HACKFORD & MALKIN, solicitors, Law Chambers, 115-119 Hotham Street, Traralgon 7399

## TENDERS

### PUBLIC WORKS DEPARTMENT

Tenders are invited for the purposes indicated hereunder and will be received at 2 Treasury Place, Melbourne, 3002, until TWO p.m. on the dates shown.

Tenders must be addressed to the Minister for Public Works with the envelope endorsed "Tender for \_\_\_\_\_".

Tenders forwarded either by mail, telegram or telex, which arrive after the closing time, will be accepted provided that the official Telecom or Australia Post time and date stamping indicates dispatch prior to the closing time. (TIME AND DATE STAMPING MUST BE REQUESTED AT SOME POST OFFICES.)

(TELEX No. AA152039)

Hand-delivered tenders must be placed in the Department's tender box, in foyer, Ground Floor, 2 Treasury Place, Melbourne.

Tender documents are available from the Contracts Office, Room 29, Ground Floor, 2 Treasury Place, Melbourne and where indicated, at offices of Inspector of Works.

Wednesday, 24 June 1987

Building, Electrical and Mechanical Services etc.

ARMATA—Refurbishment of part of existing building for student services unit, Primary School.

KURUNJANG—Metalwork, stage 2, Post Primary School.

#### Miscellaneous

MELBOURNE—Supply of interconnecting movable screens, T3527, 436 Lonsdale Street—Department of Management and Budget.

PORT MELBOURNE—Supply of furniture (office seating) for the period 1.7.87 to 30.6.89, P.W.D. Storeyard—69 Salmon Street.

PORT MELBOURNE—Supply of furniture (general seating) for the period 1.7.87 to 30.6.89, P.W.D. Storeyard—69 Salmon Street.

PORT MELBOURNE—Supply of furniture (sheet steel) for the period 1.7.87 to 30.6.89, P.W.D. Storeyard—69 Salmon Street.

PORT MELBOURNE—Supply of furniture (benches, desks and tables, etc.) for the period 1.7.87 to 30.6.89, P.W.D. Storeyard—69 Salmon Street.

Wednesday, 1 July 1987

**Building, Electrical and Mechanical Services etc.**

ABERFELDIE—Cyclic maintenance, Primary School.

KNOX—*Amended and re-advertised*: Repairs and painting, Technical School.

KURUNJANG—Floor finishes—Stage 2, Blocks 1 and 2, Post Primary School.

KURUNJANG—Painting—Stage 2, Blocks 1 and 2, Post Primary School.

KURUNJANG—Operable walls—Stage 2, Blocks 1 and 2, Post Primary School.

MELBOURNE—Fit-out to Floors 16–21 inclusive, A.C.I. House—200 Queen Street.

Wednesday, 8 July 1987

**Building, Electrical and Mechanical Services etc.**

WARRNAMBOOL—Intruder detection system, College of TAFE.

RONALD W. WALSH  
Minister for Public Works

Public Works Department  
Melbourne, 1 June 1987

LATE NOTICES

Department of Industry, Technology and Resources

MINING LEASE GRANTED

No. 974; Mineral Industries Pty Ltd; 8.7817 ha, Parish of Nowa Nowa South.

INTENTION TO RENEW A MINING LEASE  
No. 861-1; A. A. May and H. A. Sumberg; 9.18 ha, Parish of Bungyarr.

MINING LEASE EXPIRED

No. 512-1; A. J. Mahoney, P. Higgins & Reamway Pty Ltd; 1.4757 ha, Parish of Blackwood.

APPLICATIONS FOR DEVELOPMENT LEASES REFUSED

Nos 564–583 inclusive; Hewest Pty Ltd; Parishes of Castlemaine, Harcourt, Fryers, Chewton and Faraday.

Nos. 507 and 508; Keamuse Pty Ltd; Parishes of Mirboo North, Woorara and Walhalla.

No. 516; Homuse Pty Ltd; Parish of Walwa.

Nos. 517, 521–525 inclusive, 538–540 inclusive; Slamuse Pty Ltd; Parishes of Thologolong, Everton, Kiewa, Buchan, Bet Bet.

Nos. 518–520 inclusive; Tramuse Pty Ltd; Parishes of Gaffney's Creek and Woods Point.

Nos. 533–537 inclusive; Yemuse Pty Ltd; Parishes of Dargile and Redcastle.

No. 532; Loimuse Pty Ltd; Parish of Thorkidaan.

INTENTION TO GRANT A PROSPECTING AREA LICENCE

No. 233; Ando Minerals NL; 22 ha, Parish of Blackwood.

PROSPECTING AREA LICENCES GRANTED

No. 87; M. J., Kent; 198 ha, Parishes of Goongerah and Noonga.

No. 151; Dundee Mines NL; 118 ha, Parish of Moolerr.

No. 152; Dundee Mines NL; 8 ha, Parish of Moolerr.

APPLICATIONS FOR PROSPECTING AREA LICENCES REFUSED

Nos. 357–376 inclusive; Hewest Pty Ltd; Parishes of Castlemaine, Harcourt, Fryers, Chewton and Faraday.

Nos. 292 and 293; Keamuse Pty Ltd; Parishes of Mirboo South, Woorara and Walhalla.

No. 294; Homuse Pty Ltd; Parish of Walwa.  
 Nos. 295, 308-312 inclusive and 328-330 inclusive; Slamuse Pty Ltd; Parishes of Thologolong, Everton, Kiewa, Buchan, Bet Bet.

Nos. 305-307 inclusive and 331-334 inclusive; Tramuse Pty Ltd; Parishes of Gaffney's Creek and Woods Point.

Nos. 323-327 inclusive; Yemuse Pty Ltd; Parishes of Dargile and Redcastle.

No. 332; Loimuse Pty Ltd; Parish of Thorkidaan.

**APPLICATION FOR PROSPECTING AREA LICENCE TRANSFERRED**

No. 110; From I. M. Parker to Bendigo Mining NL.

**INTENTION TO GRANT A WATERLINE LICENCE**

No. 6; Automake Pty Ltd; approx 1.5 km, Parishes of Nerring and Sandhurst.

**APPLICATION FOR TAILINGS REMOVAL LICENCE REFUSED**

No. 5095; Brunswick Mining Pty Ltd; to remove tailings adjacent to Mining Treatment Plant on ML 1050.

**TAILINGS REMOVAL LICENCES FOR TREATMENT PURPOSES EXPIRED**

No. 4911; Bendigo Gold Associates, to remove tailings from the State Forest situated in the Parish of Buninyong.

**TAILINGS REMOVAL LICENCE EXPIRED**

No. 4954; Shire of Bright; to remove tailings adjacent to Harrierville Road near Germantown situated in the Parish of Bright.

**APPLICATION FOR TAILINGS TREATMENT LICENCE REFUSED**

No. 367; Planet Resources Group NL; 1.2 ha, Parish of Carisbrook.

**APPLICATION FOR TAILINGS TREATMENT LICENCE DECLARED ABANDONED**

No. 406; M. J. Roet and K. A. White; Parish of Bungal.

**INTENTION TO GRANT EXPLORATION LICENCES**

No. 1889; BHP Minerals Ltd; 475 km<sup>2</sup>, Shire of Swan Hill.

No. 1669; Sandhurst Mining NL; 137 km<sup>2</sup>, Shire of Leigh.

No. 1873; F. G. Garner; 16 km<sup>2</sup>, Shire of Maffra.

No. 1886; BHP Minerals Ltd; 492 km<sup>2</sup>, Shires of Warracknabeal and Karkaroc.

No. 1890; R. D. Foster and N. T. Motton; 80 km<sup>2</sup>, Shire of Avoca.

No. 1891; Aberfoyle Resources Ltd and Balmoral Resources NL; 170 km<sup>2</sup>, Shire of Birchip.

**EXPLORATION LICENCES GRANTED**

No. 1681; Planet Resources Group NL; 48 km<sup>2</sup>, Shire of Kara Kara.

No. 1787; Bendigo Gold Associates Pty Ltd; 95 km<sup>2</sup>, Shire of Tallangatta.

**EXPLORATION LICENCES EXTENDED AND AREAS RELINQUISHED**

No. 1408-2; P. F. Robinson and D. M. Barty; area retained 21 km<sup>2</sup>, area relinquished 7 km<sup>2</sup>, County of Anglesey.

No. 1422-2; P. F. Robinson and D. M. Barty; area retained 2.25 km<sup>2</sup>, area relinquished 1 km<sup>2</sup>, Gobur.

The above relinquished areas became available again for Exploration Licence on 30 April 1987.

**EXPLORATION LICENCE EXPIRED**

No. 1593; Poolette Holdings (Vic) Pty Ltd; 39.5 km<sup>2</sup>, County of Grant.

The above expired area will become available again for Exploration Licence on 23 November 1987.

R. C. FORDHAM

Minister for Industry, Technology and Resources

Department of Conservation, Forests and Lands

**SALE OF CROWN LAND BY PUBLIC AUCTION**

Reference No. S9072

Hallam

On Saturday, 27 June 1987 at 2.00 p.m.

On Site: 11 Harmer Road, Hallam.

**Crown Description:** Crown Allotment 14B, Section 14, Parish of Eumemmerring, County of Mornington.

**Area:** 725 m<sup>2</sup>

**Terms:** Deposit 10% of purchase price. Balance due in 60 days.

**Officer Co-Ordinating Sale:** Mr. A. Burford, Property Division, Department of Property and Services.

**Selling Agent:** Stockdale & Leggo Pty. Ltd., 144 Thomas Street, Dandenong.

J. E. KIRNER

Minister for Conservation, Forests and Lands

*Stock Diseases Act 1968*  
**APPOINTMENT OF INSPECTORS**

<i>Name</i>	<i>Classification</i>	<i>Gazette</i>	<i>Date</i>	<i>PSB Cert.</i>	<i>Date</i>
Allen, John David	Scientist, Veterinary, SCI(VET) 2	16	11.2.76		29.12.75
Allison, James Francis	Scientist, Veterinary, SCI(VET) 1	106	3.12.80		5.11.80
Archer, John Harold	Scientist SCI 1	63	20.7.77		12.7.77
Armstrong, Lewis John	Scientist, SCI 1	2	15.1.75		16.12.74
Atkins, John William	Scientist, SCI 2	89	30.9.70		31.8.70
Ault, Gregory Keith	Scientist, SCI 1	80	17.9.80		9.9.80
Badman, Rodney Terrance	Scientist, Veterinary, SCI(VET) 2	77	2.9.79		4.9.79
Balleck, Jan Charles	Scientist, Veterinary, SCI(VET) 3				
Barr, Donald Arthur	Scientist, Veterinary, SCI(VET) 4	106	3.12.80		5.11.80
Bartram, Peter	Scientist, Veterinary, SCI(VET) 2	86	15.10.86		4.6.86
Beers, Peter T.	Scientist, Veterinary, SCI(VET) 2	48	18.6.86		4.6.86
Bennett, Geoffrey K.	Scientist, SCI 1	67	6.8.86		18.6.86
Blandy, Martin Lane	Scientist, SCI 2	22	8.3.67		9.2.67
Blunden, Robert John	Scientist, SCI 2	34	7.4.71		15.3.71
Bollen, Christopher Charles	Scientist, SCI 1	2	15.1.75		16.12.74
Borland, Narelle Anne	Scientist, Veterinary, SCI(VET) 2	16	12.3.75		10.2.75
Brightling, Anthony	Scientist, Veterinary, SCI(VET) 1	126	8.12.82		18.11.82
Brown, Graham Gordon	Scientist, SCI 2	17	12.3.69		20.1.69
Bull, Austen Everard	Scientist, SCI 2	76	4.9.68		9.8.68
Bunn, Christopher M.	Scientist, Veterinary, SCI(VET) 4			154	12.1.68
Button, Christopher	Scientist, Veterinary, SCI(VET) 4	48	18.6.86		4.6.86
Caithness, Maxwell John	Scientist, SCI 2	69	14.9.66		26.8.66
Campbell, Noel John	Scientist, Veterinary, SCI(VET) 4	106	3.12.80		5.11.80
Chapman, Colin Bruce	Scientist, Veterinary, SCI(VET) 3	26	27.4.77		29.3.77
Chapman, John Stewart	Scientist, SCI 1	47	13.6.79		5.6.79
Condron, Robin James	Scientist, Veterinary, SCI(VET) 4	18	4.3.70		9.2.70
Coulson, Kenneth Hillam	Scientist, SCI 2	524	1.7.53	GIC	24.6.53
Cox, Geoffrey Arthur	Scientist, SCI 2	54	30.5.62		3.5.62
Craven, John Alexander	Regional Manager, SES-2	10	13.2.63		25.1.63
Crossing, Richard James	Scientist, Veterinary, SCI(VET) 4	46	13.5.70		10.4.70
Cumming, Peter John	Scientist, SCI 2			7499	1.10.58
Cummins, Leo J.	Scientist, Veterinary, SCI(VET) 1	48	18.6.86		4.6.86
Cutler, Ross Stanley	Scientist, Veterinary, SCI(VET) 3	27	8.4.73		22.3.73
Davis, Katherine E.	Scientist, Veterinary, SCI(VET) 1	65	19.6.85		16.5.85
Denholm, Lawrence John	Scientist, Veterinary, SCI(VET) 2	106	3.12.80		5.11.80
Drenen, Patrick Waterford	Scientist, SCI 2			3234	20.4.59
Eadie, George Ledlie	Scientist, SCI 2			9139	7.11.58
Fahy, Virgil Anthony	Scientist, Veterinary, SCI(VET) 4	106	3.12.80		5.11.80
Finnie, John Walker	Scientist, Veterinary, SCI(VET) 2	106	3.12.80		5.11.80
Flannagan, John Thomas	Scientist, Veterinary, SCI(VET) 1	26	27.4.77		29.3.77
Forsyth, William Michael	Scientist, Veterinary, SCI(VET) 2	11	19.2.69		10.1.69
Gahan, Christopher C. E.	Principal Animal Health Officer	69	14.9.66		26.8.66
Galvin, John W.	Scientist, Veterinary, SCI(VET) 2	982	1.10.83		16.9.83
Gill, Ian James	Scientist, Veterinary, SCI(VET) 2	79	24.9.75		21.8.75
Glynn, Thomas	Scientist, SCI 2	60	17.6.70		20.5.70
Gould, James Arthur	Scientist, Veterinary, SCI(VET) 2	105	25.11.70		6.11.70
Grainger, Hartley John	Scientist, SCI 2	2	9.1.70		5.12.69
Gribbin, Raymond John	Scientist, SCI 2	10	30.1.74		2.1.74
Hallam, Gary James	Scientist, SCI 2	111	21.11.73		5.11.73
Harkin, John Thomas	Scientist, Veterinary, SCI(VET) 2	56	9.6.76		6.5.76
Harris, Douglas John	Scientist, Veterinary, SCI(VET) 2	31	5.5.65		26.2.65
Harrison, Michael Allan	Principal Veterinary Officer SCI(VET) 5	66	1.7.76		20.5.76
Hawker, Graeme	Scientist, SCI 1	61	8.7.81		19.6.81
Headlam, Patten Fraser	Scientist, SCI 2	13	20.2.85		24.1.85
Heath, Susan E.	Scientist, SCI 1	39	24.4.85		4.4.85
Herbert, Lindsay Arthur	Scientist, Veterinary, SCI(VET) 3	66	3.8.77		20.7.77
Hides, Susan Jean	Scientist, Veterinary, SCI(VET) 2	76	29.7.81		2.7.81
Hill, John Fredrick	Scientist, Veterinary, SCI(VET) 1	73	21.7.82		24.6.82
Hinton, David Grenville	Scientist, SCI 2	106	3.12.80		5.11.80

Name	Classification	Gazette	Date	PSB	
				Cert.	Date
Hollier, Timothy J.	Scientist, SCI 1		25.10.83		18.10.83
Hore, Desmond Edwin	General Manager Operations SES-6			1145	14.2.57
Hum, Steven	Scientist, Veterinary, SCI(VET) 1	48	15.10.86		4.6.86
Humphrey, John D.	Scientist, Veterinary, SCI(VET) 4	48	18.6.86		4.6.86
Huntington, Peter J.	Scientist, Veterinary, SCI(VET) 1	56	23.5.84		10.4.84
Jack, Andrew Robert	Scientist, SCI 2	17	12.3.69		20.1.69
Jackson, Peter John	Scientist, Veterinary, SCI(VET) 4	49	7.6.67		10.5.67
Jeffers, Michael James	Scientist, Veterinary, SCI(VET) 1	76	28.7.82		5.7.82
Jerrett, Ian Vincent	Scientist, Veterinary, SCI(VET) 2	106	3.12.80		5.11.80
Johns, Malcolm Evan	Scientist, SCI 2			3936	16.5.60
Johnston, Noel Edgar	Scientist, Veterinary, SCI(VET) 3	106	3.12.80		5.11.80
Jolly, Jeffery	Scientist, SCI 2	42	28.5.75		24.4.75
Jones, Robert Tracey	Director Regional Vet. Lab. SCI(VET) 5	106	3.12.80		5.11.80
Jones, Thomas Evan	Principal Vet. Officer SCI(VET) 5	35	24.4.81		31.3.81
Kelly, Andrew Philip	Scientist, Veterinary, SCI(VET) 2	17	8.3.78		10.2.78
Keys, Richard George	Scientist, SCI 1	63	20.7.77		12.7.77
Lambell, Robert George	Scientist, SCI 1	63	20.7.77		12.7.77
Lancaster, Malcolm	Scientist, Veterinary, SCI(VET) 5	29	1.4.81		27.2.81
Langdon, Jeremy J.	Scientist, Veterinary, SCI(VET) 2	48	18.6.86		4.6.86
Larsen, John William	Scientist, Veterinary, SCI(VET) 2	66	1.8.79		9.7.79
Lenghaus, Cornelis	Scientist, Veterinary, SCI(VET) 4	106	3.12.80		5.11.80
Lyford, Roger Arthur	Scientist, SCI 2	1	7.1.76		8.12.75
Makin, Trevor	Scientist, SCI 1	101	7.10.81		31.8.81
McCaughan, Chris J.	Scientist, Veterinary, SCI(VET) 2	20	6.4.77		9.3.77
McCrory, John W.	Scientist, SCI 2	65	19.6.85		16.5.85
McDonald, John William	Scientist, Veterinary, SCI(VET) 2	31	10.4.63		27.2.63
McIntyre, John Angus	Scientist, SCI 1	79	24.9.75		21.8.75
McKenzie, Ian Duncan	Scientist, SCI 1	118	11.12.74		25.11.74
McOrist, Steven	Scientist, Veterinary, SCI(VET) 1	106	3.12.80		5.11.80
Medwell, Warren Douglas	Scientist, SCI 2	2	9.1.70		5.12.69
Mellar, Robert John	Scientist, SCI 1	47	7.6.78		23.5.78
Millar, Hugh W. C.	Scientist, Veterinary, SCI(VET) 4	26	27.4.77		29.3.77
Miller, George Thomas	Scientist, Veterinary, SCI(VET) 2	20	6.4.77		9.3.77
Mitchell, Geoffrey	Scientist, Veterinary, SCI(VET) 4	29	1.4.81		27.2.81
Morgan, Ian Richard	Scientist, Veterinary, SCI(VET) 4			154	12.1.68
Morris, David C.	Scientist, Veterinary, SCI(VET) 1	48	18.6.86		4.6.86
Morton, John Michael	Scientist, Veterinary, SCI(VET) 2	982	1.10.83		16.9.83
Moss, David	Scientist, SCI 2	76	4.9.68		9.8.68
Napthine, Denis Vincent	Scientist, Veterinary, SCI(VET) 2	42	28.5.75		18.4.75
Nash, Gordon Alan	Scientist, SCI 1	2	15.1.75		16.12.74
Nicholls, Terrence John	Director, Regional Vet. Lab. SCI(VET) 5	84	2.11.77		14.10.77
Nurse, Garth Henry	Scientist, Veterinary, SCI(VET) 2	6	21.1.81		22.12.80
Oldroyd, Benjamin P.	Scientist, SCI 2	13	20.2.85		24.1.85
Oliver, Christopher J.	Scientist, SCI 2	60	17.6.70.		20.5.70
Paterson, Peter John	Scientist, SCI 2			3936	16.5.60
Peisley, Frank Robert	Scientist, SCI 2	81	26.8.70		16.8.70
Penson, Peter James	Principal Vet. Officer, SCI(VET) 4	79	24.9.75		21.8.75
Phillips, Michael	Scientist, SCI 1	33	7.5.80		10.4.80
Powell, William George	Scientist, SCI 2	17	12.3.69		20.1.69
Pratt, Peter Douglas	Scientist, SCI 2			6105	11.8.58
Prime, Robert W.	Scientist, SCI 1	65	19.6.85		16.5.85
Pritchard, David Howard	Scientist, Veterinary, SCI(VET) 2	106	3.12.80		5.11.80
Rahaley, Robert S.	Scientist, Veterinary, SCI(VET) 4	29	1.4.81		27.2.81
Reece, Rodney Leon	Scientist, Veterinary, SCI(VET) 2				15.9.78
Rees, John Bryn	Scientist, Veterinary, SCI(VET) 8	79	24.9.75		21.8.75
Ridge, Sally	Scientist, Veterinary, SCI(VET) 1	86	15.10.86		4.6.86
Rifkin, George Gerald	Director Regional Vet. Lab. SCI(VET) 5	106	3.12.80		5.11.80
Ross, Alan Roderick	Scientist, SCI 2	76	4.9.68		9.8.68
Roycroft, Cristopher R.	Scientist, SCI 2	76	4.9.68		9.8.68
Rubira, Richard James	Scientist, Veterinary, SCI(VET) 2	82	21.8.74		2.7.74
Salisbury, James Ralph	Principal Vet. Officer, SCI(VET) 5	106	3.12.80		5.11.80
Scott, Peter	Scientist, Veterinary, SCI(VET) 2	29	1.4.81		27.2.81



Name	Classification	Gazette	Date	PSB Cert.	Date
Seiler, Robert J.	Scientist, Veterinary, SCI(VET) 2	48	18.6.86		4.6.86
Sheil, Michael John	Scientist, Veterinary, SCI(VET) 2	31	31.3.82		2.3.82
Simpson-White, Patrick H.	Scientist, Veterinary, SCI(VET) 2				16.9.74
Sims, Leslie David	Scientist, Veterinary, SCI(VET) 1	106	3.12.80		5.11.80
Snelson, Stephen	Scientist, SCI 1	61	8.7.81		19.6.81
Stelmasiak, Theodor	Scientist, Veterinary, SCI(VET) 4	106	3.12.80		5.11.80
Stephens, Leonard Russell	Scientist, Veterinary, SCI(VET) 5	26	27.4.77		29.3.77
Stranger, James William	Scientist, SCI 2	77	12.8.70		9.7.70
Sykes, William Everett	Scientist, Veterinary, SCI(VET) 4	28	26.4.72		27.3.72
Tate, Stephen	Scientist, Veterinary, SCI(VET) 2	53	17.6.81		27.5.81
Thomas, Terrance R.	Scientist, Veterinary, SCI(VET) 2	20	6.4.77		9.3.77
Toohey, Leslie Alexander	Scientist, SCI 1	94	3.11.76		13.9.76
Tulloch, John Douglas	Scientist, Veterinary, SCI(VET) 4	17	8.3.78		10.2.78
Turner, Andrew Joseph	Manager, Product Stds SES-2	31	10.4.63		27.2.63
Tweddle, Neil Edward	Principal Vet. Officer SCI(VET) 5	17	12.3.69		20.1.69
Vizard, Andrew Lancelot	Scientist, Veterinary, SCI(VET) 1	982	1.10.83		16.9.83
Ward, Keith Lawrence	Scientist, SCI 2	59	13.6.62		14.5.62
Watt, Gerard Francis	Scientist, SCI 1	63	20.7.77		12.7.77
Webber, Jonathon J.	Scientist, Veterinary, SCI(VET) 4	126	8.12.82		18.11.82
Whinney, Paul David	Scientist, SCI 1	82	5.8.81		10.7.81
White, Matthew Barry	Scientist, Veterinary, SCI(VET) 3	40	8.6.66		12.5.66
White, Wallace Ernest	Mgr. Animal Health & Welfare Stds. SES-2	10	13.2.63		25.1.63
Williams, David M. D.	Scientist, Veterinary, SCI(VET) 2	48	18.6.86		4.6.86
Williams, Desmond D.	Scientist, SCI 1	125	16.3.83		15.2.83
Williams, Peter James	Scientist, SCI 2	82	30.8.78		27.7.78
Wootton, William Kenneth	Scientist, SCI 2	34	7.4.71		15.3.71
Yeh, Felix James	Scientist, Veterinary, SCI(VET) 4	17	8.3.78		10.2.78

TERRY HILL

Manager, Personnel

Department of Agriculture and Rural Affairs

In The Supreme Court of the State of Victoria  
SALE BY THE SHERIFF

On 23 July 1987 at 2.30 p.m. at the Sheriff's Office, 287 Springvale Road, Glen Waverley (unless process be stayed or satisfied).

All the estate and interest (if any) of Hilton Raymond Dallwitz and Elizabeth Helen Dallwitz of 14 Fernshaw Place, Mt. Eliza as joint proprietors of an estate in fee simple in the land described in Certificate of Title Volume 8781 Folio 071 upon which is erected a dwelling and known as No. 14 Fernshaw Place, Mount Eliza.

Registered Mortgages L706615D, L912957P and L972730L affects the said estate and interest.

Terms—Cash only

7430 A. STANLEY, Sheriff's Officer

In the Supreme Court of the State of Victoria  
SALE BY THE SHERIFF

On 16 July 1987 at 2.30 p.m. at the Sheriff's Office, 287 Springvale Road, Glen Waverley (unless process be stayed or satisfied).

All the estate and interest (if any) of Thomas Fung and Patricia Fung of 14 Hillside Road, Bulleen, joint proprietors of an estate in fee simple in the land described in the Certificate of

Title Volume 8100 Folio 214 upon which is erected a dwelling and known as 14 Hillside Road, Bulleen.

Registered Mortgage K571832 affects the said estate and interest.

Terms—Cash only

7431 A. STANLEY, Sheriff's Officer

In the Supreme Court of the State of Victoria  
SALE BY THE SHERIFF

On 16 July 1987 at 2.30 p.m. at the Sheriff's Office, 287 Springvale Road, Glen Waverley (unless process be stayed or satisfied).

All the estate and interest (if any) of Peter John Gilligan, 53 Baden Powell Drive, Frankston shown on Certificate of Title as Peter James Gilligan, proprietor of an estate in fee simple in the land described in the Certificate of Title Volume 9486 Folio 615 upon which is erected a dwelling and known as 6 Parkside Grove, Frankston.

Registered Mortgage K810481 and Caveats K27788, M285367V affects the said estate and interest.

Terms—Cash only

7432 A. STANLEY, Sheriff's Officer

In The Supreme Court of the State of Victoria  
SALE BY THE SHERIFF

On 23 July 1987 at 2.30 p.m. at the Sheriff's Office, 287 Springvale Road, Glen Waverley (unless process be stayed or satisfied).

All the estate and interest (if any) of Lyn Rosemary Hardidge of Lot 11 McMahons Road, Woori Yallock, joint proprietor with Edward Maxwell Hardidge of an estate in fee simple in the land described in the Certificate of Title Volume 8720 Folio 896 upon which is erected a dwelling and known as Lot 11, McMahons Road, Woori Yallock.

Registered Mortgage K523721 and Caveat M418733R affects the said estate and interest.

Terms—Cash only

7433 A. STANLEY, Sheriff's Officer

In the Supreme Court of the State of Victoria  
SALE BY THE SHERIFF

On 30 July 1987 at 2.30 p.m. at the Sheriff's Office, 287 Springvale Road, Glen Waverley (unless process be stayed or satisfied).

All the estate and interest (if any) of Rhonda H. Moss of 14 Sussex Street, Ringwood, shown on Certificate of Title as Rhonda Helen Moss, joint proprietor with William George Moss of an estate in fee simple in the land described in the Certificate of Title Volume 8146 Folio 260 upon which is erected a dwelling and known as 14 Sussex Street, Ringwood.

Registered mortgage K407199 and Caveats L101931B, L286979F affects the said estate and interest.

Terms—Cash only

7434 A. STANLEY, Sheriff's Officer

In the Supreme Court of the State of Victoria  
SALE BY THE SHERIFF

On 23 July 1987 at 2.30 p.m. at the Sheriff's Office, 287 Springvale Road, Glen Waverley (unless process be stayed or satisfied).

All the estate and interest (if any) of Sandra Elizabeth Ohlew of 117 Camms Road, Cranbourne, joint proprietor with Gunter Jurgen Ohlew of an estate in fee simple in the land described in the Certificate of Title Volume 8892 Folio 046 upon which is erected a dwelling and known as (Lot 99) 17 Camms Road, Cranbourne.

Registered mortgage L445179T and Caveat L786860B.

Terms—Cash only

7435 A. STANLEY, Sheriff's Officer

In the Supreme Court of the State of Victoria  
SALE BY THE SHERIFF

On 30 July 1987 at 2.30 p.m. (unless process be stayed or satisfied).

All the estate and interest (if any) of Lazaros Papaikononou of 38 Spensley Street, Clifton Hill, joint proprietor with Ioanna Papaikononou of an estate in fee simple in the land described in the Certificate of Title Volume 8800 Folio 939 upon which is erected a dwelling and known as 38 Spensley Street, Clifton Hill.

Registered mortgages K713855, M04747F affects the said estate and interest.

Terms—Cash only

7436 A. STANLEY, Sheriff's Officer

In The Supreme Court of the State of Victoria  
SALE BY THE SHERIFF

On 16 July 1987 at 2.30 p.m. at the Sheriff's Office, 287 Springvale Road, Glen Waverley (unless process be stayed or satisfied).

All the estate and interest (if any) of Hatice, Pektas and Mehmet Pektas of 1 Vivaldi Court, Templestowe shown on Certificate as Hatice Pektas and Mehmet Adnan Pektas, joint proprietors with Sazai Bulent Pektas, Ahmet Feyyaz Pektas, and Mehmet Levent Pektas of an estate in fee simple in the land described in the Certificate of Title Volume 9250 Folio 766 upon which is erected a dwelling and known as 1 Vivaldi Court, Templestowe.

Registered mortgage M661649N affects the said estate and interest.

Terms—Cash only

7437 A. STANLEY, Sheriff's Officer

FREDERICK ANDREW GOLDSTONE, late of 719 Toorak Road, Malvern, in the State of Victoria, consulting engineer, deceased

Creditors, next of kin and others having claims in respect of the estate of the deceased who died on 26 January 1987 are required by the executrix Barbara Ethel Goldstone of 719 Toorak Road, Malvern, widow to send particulars to her by 14 August 1987 after which date the executrix may convey or distribute the assets, having regard only to the claims of which she then has notice.

COHENS FRENKEL KEFFORD NEW,  
solicitors, of 114 William Street, Melbourne

7416

VERONICA WHELAN, (also known as Veronica Fiscalini) late of 80 Williams Road, Windsor in the State of Victoria, retired chiropodist, deceased

Creditors, next of kin, and others having claims in respect of the estate of the deceased who died on 27 July 1986 are required by the executrix Elinor Rabinov (in the will called Eleanor Rabinov) of 52 North Road, Brighton, pharmacist to send particulars to her by 14 August 1987 after which date the executrix may convey or distribute the assets having regard only to the claims of which she then has notice.

COHENS FRENKEL KEFFORD NEW, solicitors, of 114 William Street, Melbourne

7417

STEPHEN MARTIN GUY (deceased), late of 22 Drysdale Drive, Trott Park, S.A., died on 15 April 1987

Any persons claiming to be dependant upon the deceased are requested to send particulars of their claims to "Life Claims Department, Australian Eagle Ins. Co. Ltd., G.P.O. Box 1883R, Melbourne 3001", within two months of the date of this notice, after which date the deceased's entitlement will be distributed in accordance with the provisions of the Eagle Retirement Fund Trust Deed, having regard only to the claims which have been notified.

7418

Creditors, next of kin and others having claims in respect of the estate of William Richard Griffith late of 27 Waldemar Road, Eaglemont, company director, deceased who died on 4 July 1986 and probate of whose will has been granted to Barbara Lorraine Griffith of 7 Thomas Street, Eaglemont widow are required to send particulars of their claims to the said executrix care of the undermentioned solicitors by 10 August 1987 after which date she will distribute the assets having regard only to the claims of which she then has notice.

PEARCE & WEBSTER, solicitors, 51 Queen Street, Melbourne

7419

Creditors, next of kin and others having claims in respect of the estate of Ernest Wesley Barrie late of Melton, farmer, deceased are to send particulars of their claims to the Executor Kenneth Douglas Doig care of the undermentioned solicitors by 11 August 1987 after which date the Executor will distribute the assets having regard to the claims of which he then has notice.

HENDERSON & BALL of 722 High Street, East Kew, solicitors

7426

Creditors, next of kin and others having claims in respect of the estate of Hilda May Macri, late of Flat 2, 12 Peacock Street, West Brunswick, widow, deceased who died on 14 January 1987 are to send the particulars of their claims to ANZ Executors & Trustee Company Limited of 94 Queen Street, Melbourne by 19 August, 1987 after which date it will distribute the assets having regard only to the claims of which it then has notice.

7427

Creditors, next of kin and other persons having claims in respect of the estate of William Melville McDonald late of 89 Berkeley Street, Hawthorn in the State of Victoria, medical practitioner who died on 24 September 1986 are required by the Executrix Susan Officer McDonald of 89 Berkeley Street, Hawthorn in the said State, widow, to send particulars of their claims to her care of the undersigned by 10 August 1987 after which date she will convey or distribute the assets of the estate having regard only to the claims of which she then has notice.

MINTER ELLISON, solicitors, 500 Collins Street, Melbourne

7428

Creditors, next of kin and others having claims in respect of the estate of Robert Bridge Monkhouse late of George Vowell Centre, Cobb Road, Mount Eliza, retired, deceased who died on 17 January 1987 are required to send particulars of their claims to the Executors Malcolm Wesson of 8 Attunga Crescent, Seaford and Lillian Iris Howard of 7 Blair Avenue, Frankston on or before 10 August 1987 after which date they will distribute the assets having regard only to the claims of which they then had notice.

WHITE CLELAND, solicitors, 108 Young Street, Frankston

7429

CORNELIUS JOHN McCARTHY, late of Little Sisters of the Poor, St. Georges Road, Northcote, clergyman, deceased

Creditors, next of kin and others having claims in respect of the estate of the abovenamed deceased who died on 9 February 1987 are to send particulars of their claims to the executor Patrick Maye care of the undermentioned solicitors by 17 August 1987 after which date the said executor will distribute the assets having regard only to the claims of which he then has notice.

O'BRIEN & GALANTE, solicitors, 27 Norwood Crescent, Moonee Ponds

7420

Creditors, next of kin and others having claims in respect of the estate of Elsie McNair late of 62 Blyth Street, Brunswick in the State of Victoria, home duties, deceased who died on 15 February 1985 are required by the Administrator Eric French Gentleman of 16 Wolstencroft Street, Bendigo in the said State to send particulars of their claims to the said administrator care of the undermentioned solicitors by 5 August 1987 after which date the said administrator will convey or distribute the assets of the deceased having regard only to the claims of which the said administrator then has notice.

Messrs. MAKARUCHA & De MARCO,  
solicitors, of 250 Glenroy Road, Glenroy 7421

Creditors next of kin and others having claims in respect of the estate of Stuart Stanley Playle (also known as Stuart Joseph Playle) late of Unit 4, 587 Toorak Road, Toorak gentleman, deceased who died on 7 March 1987 are required by the personal representatives The Union-Fidelity Trustee Company of Australia Limited of 100 Exhibition Street, Melbourne and Janice Hunter Kirk of 10/159 Alexandra Avenue, Toorak, married woman to send particulars to them by 4 August 1987 after which date the personal representatives may convey or distribute the assets having regard only to the claims of which they then have notice.

Dated 3 June 1987.

ANDERSON RICE, solicitors, of 51 Queen Street, Melbourne 7422

GWENDOLINE DOROTHY WYLIE, late of 2 Aberdeen Street, Geelong West in the State of Victoria, married woman, deceased

Creditors, next of kin and all persons having claims against the estate of the abovenamed are required by The Union Fidelity Trustees Company of Australia Limited of 100 Exhibition Street, Melbourne in the said State the Executor of the deceased's estate to forward particulars on or before 20 July 1987 after which date the assets of the estate will be distributed having regard only to the claims of which notice has been so given.

COULTER, BURKE & FAZIO, solicitors, 68 Myers Street, Geelong 7423

NOTICE OF MAKING OF  
STATUTORY RULES  
WHICH ARE NOT YET  
AVAILABLE

Notice is given of the making of the following Statutory Rules:

- Seeds Act 1982*
- 103/1987 Seeds (Fees) Regulations 1987
- Stock Diseases Act 1968*
- 104/1987 Stock Diseases (Fees) Regulations 1987
- Magistrates' Courts Act 1971*
- 105/1987 Magistrates Court (Fees, Costs and Charges) (Amendment) Regulations 1987
- Co-operative Housing Societies Act 1986*
- 106/1987 Co-operative Housing Societies (General) (Amendment) Regulations 1987
- Health Act 1958*
- 107/1987 Health (Private Hospitals—Notification of Interest) Regulation 1987
- Medical Practitioners Act 1970*
- 108/1987 Medical Practitioners (Private Hospitals—Notification of Interest) Regulations 1987
- Transport Act 1983*
- 109/1987 Transport (Road Traffic) (Speed Limit Amendment) Regulations 1987
- Melbourne and Metropolitan Board of Works Act 1958*
- 110/1987 By-Law No. 228 Fees for Restriction and Restoration of Water Supply

	<i>Melbourne and Metropolitan Board of Works Act 1958</i>		<i>Public Authorities Marks Act 1958</i>
113/1987	By-Law No. 232 Water Supply	125/1987	By-Law No. 229 Approving and Stamping of Materials
	<i>Road Safety Act 1986</i>		<i>Melbourne and Metropolitan Board of Works Act 1958</i>
116/1987	Road Safety (Procedures) (Further Amendment) Regulations 1987	126/1987	Special By-Law 31 Fees for Water Supply and Sewerage Services to Non-Rateable Property and Cultural and Recreational Lands
	<i>Hospital and Charities Act 1958</i>		
117/1987	Hospitals and Charities (Amendment No. 1) Regulations 1987		
	<i>Agricultural Chemicals Act 1958</i>		
118/1987	Agricultural Chemicals (Fees) Regulations 1987		
	<i>Agricultural Chemicals Act 1958</i>		
119/1987	Pesticides (Fees) Regulations 1987		
	<i>Farm Produce Merchants and Commission Agents Act 1965</i>		
120/1987	Farm Produce Merchants and Commission Agents (Fees) Regulations 1987		
	<i>Companies (Application of Laws) Act 1981</i>		
121/1987	Companies (Application of Laws) (Retirement Villages Exemption) Regulations 1987		
	<i>Retirement Villages Act 1986</i>		
122/1987	Retirement Villages Regulations 1987		
	<i>Transport Act 1983</i>		
123/1987	Victoria Transport Borrowing Agency (Bonded Stocks) (Revocation) Regulations 1987		
	<i>Transport Act 1986</i>		
124/1987	Transport Accident (Charges Amendment) Regulations 1987		

**NOTICE OF MAKING  
AND AVAILABILITY OF  
STATUTORY RULES**

In pursuance of the provisions of the *Subordinate Legislation Act 1962* and the Regulations made thereunder notice is given of the making and availability of the following Statutory Rules:

Note: The date specified after each Statutory Rule is the date it was first obtainable from—

VGPO Bookshop  
Information Victoria Centre  
318 Lt Bourke Street, Melbourne

	<i>Melbourne and Metropolitan Board of Works Act 1958</i>	
111/1987	By-Law No. 230 Rate Certificate Fee	
10 June 1987		40c
	<i>Melbourne and Metropolitan Board of Works Act 1958</i>	
112/1987	By-Law No. 231 Encumbrance Certificate Fee	
10 June 1987		40c
	<i>Melbourne and Metropolitan Board of Works Act 1958</i>	
114/1987	By-Law No. 233 Trade Waste	
10 June 1987		40c
	<i>Melbourne and Metropolitan Board of Works Act 1958</i>	
115/1987	By-Law No. 234 Plumbing Code and Sewerage Regulations	
10 June 1987		40c



1526 G 22 10 June 1987

*Victoria Government Gazette*



---

*Victoria Government Gazette*

*G 22 10 June 1987 1527*

1528 G 22 10 June 1987

*Victoria Government Gazette*

---

*Victoria Government Gazette*

*G 22 10 June 1987 1529*

---

1530 G 22 10 June 1987

*Victoria Government Gazette*

---

*Victoria Government Gazette*

*G 22 10 June 1987 1531*

1532 G 22 10 June 1987

*Victoria Government Gazette*

*Victoria Government Gazette*

*G 22 10 June 1987 1533*

## CONTENTS

	Page
Appointments	1494
Cemeteries—Scale of Fees	1491
Contracts	1492
Contracts Accepted—Amendments	1492
Estates of Deceased Persons	1484
Government Notices	1475
Late Notices	1515
Notice of Making Statutory Rules	1522
Orders in Council—	
Acts—Crown Land (Reserves); Land; Urban Land Authority; River Improvement; Water; Water and Sewerage Authorities (Restructuring); Libraries; Crown Land (Reserves); Constitution Act Amendment; Transport	1495
Private Advertisements	1499
Proclamations	1473
Regulations—	
Acts—Police	1485
Tenders	1514

**No. G 22—General Government Gazette**

A Victorian Government Publication

Published by VGPO

Melbourne Victoria Australia

© State of Victoria

This publication is copyright. No part may be reproduced by any process except in accordance with the provisions of the Copyright Act

Address all inquiries to the Government Printer for the State of Victoria

PO Box 203 North Melbourne 3051 Victoria Australia

ISSN 0819—5471

Further copies of this publication can be obtained from VGPO Bookshop

Information Victoria Centre

318 Lt Bourke Street Melbourne

(PO Box 203 North Melbourne 3051)

By Authority F D Atkinson Government Printer Melbourne

Recommended Retail Price \$1.10