

# VICTORIA GOVERNMENT GAZETTE

No. G 29 Wednesday 29 July 1987

By Authority F D Atkinson Government Printer Melbourne

**GENERAL**

## Gazette Services

The *Victoria Government Gazette* (VGG) is published by VGPO for the State of Victoria and is produced in three editions.

VGG General is published each Wednesday and provides information regarding Acts of Parliament and their effective date of operation; Government notices; requests for tenders; as well as contracts and contracts accepted. Private notices are also published.

VGG Special is published any day when required for urgent or special Government notices. VGG Special is made available automatically to subscribers of VGG General.

VGG Periodical is published on Monday when required and includes specialised information eg. Medical, Dental, Pharmacist's Registers, etc.

## Government Advertising

### Publishing Details

The following Guidelines should be followed to ensure publication of Government material in the *Victoria Government Gazette*.

- Duplicate copies should be submitted for use by the Gazette Officer.
- Material submitted to the Executive Council for gazettal will normally be published in the following week's issue.
- Where urgent gazettal is required, contact:  
Gerd Gaspar  
Gazette Officer  
Department of the Premier and Cabinet  
2nd Floor 1 Treasury Place  
Melbourne 3000  
Telephone Inquiries (03) 651 5153
- Government advertising other than material for the consideration of the Executive Council should be forwarded to the Gazette Office no later than 9.30 am on Tuesday.
- Lengthy or complicated notices should be forwarded several days before publication.
- Proofs will be supplied only when requested or at the direction of the Gazette Officer.
- No additions or amendments to material for publication will be accepted by telephone.
- Double rates for advertising in the Special Gazette will apply.

## Private Advertising

### Publishing Details. Send copy to:

VGG Coordinator  
Gazette Advertising  
VGPO  
66-112 Macaulay Road  
North Melbourne  
(PO Box 203 North Melbourne 3051)  
Telephone inquiries (03) 320 0100  
Fax No. (03) 329 2696

### Advertising Rates and Payment

Single column × cm/part cm \$3.85  
Double column × cm/part cm \$7.70  
Full page \$161.70

All private advertising MUST be paid for in advance, prior to any gazettal. Cheques should be made payable to 'VGPO'.

### Advertisers should note:

- There are approximately 20 words to each column centimetre depth.
- Signatures (in particular) and proper names must also be in block letters.
- All material should be double spaced.
- Advertisements can be faxed, and a cover sheet should be used, marked to the attention of the Gazette Coordinator.
- Documents not clearly prepared and in the exact format for gazettal will be returned to the sender unpublished.
- Late copy received at VGPO after 3.30 pm Tuesday will be placed in the following issue of VGG, irrespective of any date/s mentioned in the copy (unless otherwise advised).

### Copy Deadline

11.00 am Tuesday (Normal Rates)  
3.30 pm Tuesday (Double Rates)

## Subscriptions

VGG is available by three subscription services:

General and Special—\$100 each year  
General, Special and Periodical—\$115 each year  
Periodical—\$60 each year

Subscriptions are payable in advance and accepted for a period of one year. All subscriptions are on a firm basis and refunds for cancellations will not be given.

All payments should be made payable to VGPO.

Subscription inquiries: (03) 320 0217

**PROCLAMATIONS**

*Planning Appeals (Amendment) Act 1987*  
**PROCLAMATION OF COMMENCEMENT**

I, J. Davis McCaughey, Governor of Victoria, acting with the advice of the Executive Council and under the power found in section 2 of the *Planning Appeals (Amendment) Act 1987*, fix 1 August 1987 as the day on which the Act comes into operation.

Given under my hand and the seal of Victoria on 28 July 1987.

(L.S.) J. DAVIS McCAUGHEY  
 By His Excellency's Command  
 J. H. KENNAN  
 Attorney-General

*Local Government Act 1958*  
**PROCLAMATION OF PUBLIC HIGHWAY**  
 Shire of Portland

I, J. Davis McCaughey, Governor of Victoria acting with the advice of the Executive Council and under section 519 of the *Local Government Act 1958* proclaim the road shown by hatching on the plan hereunder to be a public highway.

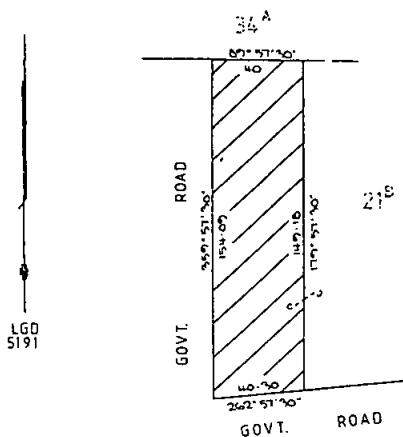

Given under my hand and the seal of Victoria on 21 July 1987

(L.S.) J. DAVIS McCAUGHEY  
 By His Excellency's Command  
 J. L. SIMMONDS  
 Minister for Local Government

*Agricultural Chemicals Act 1958*  
**PROCLAMATION**

Prescribing DDT to be a Prohibited Constituent of any Agricultural Chemical

and

Prescribing Dieldrin to be a Prohibited Constituent of any Agricultural Chemical Used Other Than for Certain Purposes

I, J. Davis McCaughey, Governor of Victoria, acting with the advice of the Executive Council and under sections 6A and 10A of the *Agricultural Chemicals Act 1958*:

1. Amend the Proclamation made on 20 January 1987 and published in the *Government Gazette* of 21 January 1987 by deleting items 7 and 8 of the Proclamation.

2. Prescribe DDT to be a prohibited constituent of any agricultural chemical.

3. Prescribe dieldrin to be a prohibited constituent of any agricultural chemical used for any purpose other than as an insecticide—

- (a) for soil treatment for protection against subterranean termites in the case of buildings under construction, or for the treatment of subterranean termite infestation in existing buildings, except that in dairies, milking sheds, poultry houses, sheep pens, pig sties, feed lot structures and other animal houses for food producing animals it may only be used for soil treatment for protection against subterranean termites in the case of buildings under construction; or
- (b) for the control of ants and argentine ants for quarantine purposes.

Given under my hand and the seal of Victoria on 28 July 1987.

(L.S.) J. DAVIS McCAUGHEY  
 By His Excellency's Command  
 EVAN WALKER  
 Minister for Agriculture and Rural Affairs

*Chattel Securities Act 1987*  
**PROCLAMATION OF COMMENCEMENT**

I, J. Davis McCaughey, Governor of Victoria, acting on the advice of Executive Council and under section 2 of the *Chattel Securities Act 1987*, fix 1 August 1987 as the day on which that Act comes into operation.

Given under my hand and seal of Victoria on 21 July 1987.

(L.S.) J. DAVIS McCAUGHEY  
 By His Excellency's Command  
 P. C. SPYKER  
 Minister for Consumer Affairs

*Motor Car Traders Act 1986*

**PROCLAMATION OF COMMENCEMENT**

I, J. Davis McCaughey, Governor of Victoria, acting on the advice of Executive Council and under section 2 of the *Motor Car Traders Act 1986*, fix:

1 October 1987 as the day on which sections 43 and 44 of the Act comes into operation;

1 January 1988 as the day on which section 16 of the Act, except for sub-section (9) of that section, comes into operation;

1 April 1988 as the day on which sub-section (9) of section 16 of the Act comes into operation; and

1 August 1987 as the day on which all other provisions of the Act except section 53 come into operation.

Given under my hand and the seal of Victoria on 21 July 1987.

(L.S.) J. DAVIS McCAUGHEY  
By His Excellency's Command  
P. C. SPYKER  
Minister for Consumer Affairs

**MUNICIPAL DISTRICT OF THE SHIRE OF LEIGH**

DEREEL—Crown Allotment 6B, section 6, Township of Dereel and Crown Allotment A12c, Parish of Dereel as shown on Certified Plan No. 108449 lodged in the Central Plan Office—(Rs. 13135).

Given under my hand and the seal of Victoria on 21 July 1987.

(L.S.) J. DAVIS McCAUGHEY  
By His Excellency's Command  
J. E. KIRNER  
Minister for Conservation, Forests and Lands

*Land Act 1958*

**PROCLAMATION OF ROADS**

I, J. Davis McCaughey, Governor of Victoria acting with the advice of the Executive Council and under section 25 (3) (c) of the *Land Act 1958* proclaim as roads the following lands:

**MUNICIPAL DISTRICT OF THE SHIRE OF TAMBO**

COLQUHOUN—The land in the Parish of Colquhoun as indicated by hatching on plan hereunder—(L9-1579).

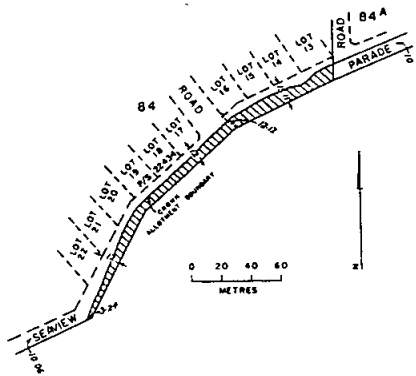

### GOVERNMENT NOTICES

#### *Cemeteries Act 1958*

#### SCALE OF FEES OF THE TIMOR PUBLIC CEMETERY

In pursuance of the powers conferred upon them by the Cemeteries Act the trustees of the Timor Public Cemetery hereby make the following scale of fees, which shall come into operation upon publication in the *Government Gazette*, and from and after such publication every scale of fees heretofore made by the said trustees shall be and is hereby rescinded to the extent to which it conflicts with this scale.

	\$
Land 2.44 m × 1.22 m	75.00
Sinking grave 1.83 m deep	110.00
Interment fee	35.00
Reopening grave (no cover)	110.00
Reopening grave (with cover)	120.00
Permission to erect a headstone or monument—5% of cost with a minimum \$15.00	
Exhumation charge	300.00
Search fee per request	15.00

P. J. IPSEN, Trustee  
T. F. LONG, Trustee  
K. PARKER, Trustee

Approved by the Governor in Council, 21 July 1987—L. A. FISHER, Acting Clerk of the Executive Council

#### *Cemeteries Act 1958*

#### SCALE OF FEES OF THE GRANYA PUBLIC CEMETERY

In pursuance of the powers conferred upon them by the Cemeteries Act the trustees of the Granya Public Cemetery hereby make the following scale of fees, which shall come into operation upon publication in the *Government Gazette*, and from and after such publication every scale of fees heretofore made by the said trustees shall be and is hereby rescinded to the extent to which it conflicts with this scale.

	\$
Land 1.22 m × 2.44 m	20.00

J. F. TERLICH, Trustee  
W. WEBB, Trustee  
C. WEBB, Trustee

Approved by the Governor in Council, 21 July 1987—L. A. FISHER, Acting Clerk of the Executive Council

#### *Cemeteries Act 1958*

#### SCALE OF FEES OF THE NEERIM PUBLIC CEMETERY

In pursuance of the powers conferred upon them by the Cemeteries Act the trustees of the Neerim Public Cemetery hereby make the following scale of fees, which shall come into operation in the *Government Gazette*, and from and after such publication every scale of fees heretofore made by the said trustees shall be and is hereby rescinded to the extent to which it conflicts this scale.

	\$
<i>Lawn Section</i>	
Lawn grave	200.00
Interment fee (including sinking)	190.00
Plaque and flower container	130.00
Reopening grave	190.00
Plaque	130.00
<i>Denominational Section</i>	
Land	200.00
Interment fee (including sinking)	190.00
Reopening	190.00
Removal of slab	75.00
10% of all monumental costs	
Child up to 6 years plus plaque	120.00
Ashes—interment plus plaque	50.00
<i>Miscellaneous Charges</i>	
Saturdays—Public Holidays (extra)	100.00

P. YOUNG, Trustee  
T. PARKER, Trustee  
J. CUNUFFE, Trustee

Approved by the Governor in Council, 21 July 1987—L. A. FISHER, Acting Clerk of the Executive Council

#### *Cemeteries Act 1958*

#### SCALE OF FEES OF THE TYLDEN PUBLIC CEMETERY

In pursuance of the powers conferred upon them by the Cemeteries Act the trustees of the Tylden Public Cemetery hereby make the following scale of fees, which shall come into operation upon publication in the *Government Gazette*, and from and after such publication every scale of fees heretofore made by the said trustees shall be and is hereby rescinded to the extent to which it conflicts with this scale.

	\$
<i>Public Graves</i>	
Interment in grave without exclusive right—stillborn child	40.00
Interment in grave without exclusive right—others	60.00
Number peg or label	15.00

<i>Private Graves</i>	
Land 2.44 m × 1.22 m	80.00
Own selection of land (extra)	60.00

<i>Sinking Charges for Private Graves</i>	
Sinking grave 1.83 m deep	150.00
Each additional 0.3 m	35.00
Sinking oversize grave	50.00
Cancellation of order to sink (if commenced)	30.00
Reopening grave (no cover)	130.00
Reopening grave (with cover)	140.00

<i>Miscellaneous Charges</i>	
Interment fee	40.00
Interment outside prescribed hours, or on Saturdays, Sundays or Public Holidays or without due notice	60.00
Certificate of right of burial	15.00
Number plate of brick	20.00
Permission to erect a headstone or monument—5% of cost with a minimum of \$15.00	
Permission to construct a brick grave or to erect any stone kerb, brick tile-work or concrete—5% of cost with a minimum of \$15.00	
Exhuming the remains of a body (when authorised)	350.00
Interment of ashes in a private grave	50.00

L. G. O'BRIEN, Trustee  
W. T. HICKEY, Trustee  
A. J. TRANTER, Trustee

Approved by the Governor in Council, 21 July 1987—L. A. FISHER, Acting Clerk of the Executive Council

*Cemeteries Act 1958*  
**SCALE OF FEES OF THE SHEPPARTON PUBLIC CEMETERY**

In pursuance of the powers conferred upon them by the Cemeteries Act the trustees of the Shepparton Public Cemetery hereby make the

following scale of fees, which shall come into operation upon publication in the *Government Gazette*, and from and after such publication every scale of fees heretofore made by the said trustees shall be and is hereby rescinded to the extent to which it conflicts with this scale.

	\$
<i>Public Graves</i>	
Interment in grave without exclusive right—adult	100.00
Interment in grave without exclusive right—stillborn child	55.00

<i>Private Graves</i>	
Land 2.44 m × 1.22 m	300.00
Sinking a grave	250.00
Interment of ashes in a private grave	55.00
Memorial Wall Niche	125.00

<i>Extra Charges</i>	
Interment on a public holiday	100.00
Interment on a Saturday	75.00

<i>Miscellaneous</i>	
Permission to erect a headstone on a monument—7% of cost	
Concrete vault and land (when available)	1500.00
Interment in Vault	250.00

S. W. MORRELL, Trustee  
A. R. CAPLE, Trustee  
B. V. RYAN, Trustee

Approved by the Governor in Council, 21 July 1987—L. A. FISHER, Acting Clerk of the Executive Council

**CONTRACTS ACCEPTED**  
Public Works Department

His Excellency the Administrator of the State of Victoria by and with the advice of the Executive Council thereof has by Order made on 21 July 1987 approved of the acceptance by the Minister of Public Works of the undermentioned offer without public tenders being invited, viz:

Offer of Gryffin Pty. Ltd., for the provision of security works at Her Majesty's Prison, Pentridge, for the sum of Two Hundred and Seventy Five Thousand Five Hundred and Eighty three Dollars (\$275 583.00).

L. A. FISHER  
Acting Clerk of the Executive Council  
At the Executive Council Chamber,  
Melbourne, 21 July 1987

*Private Agents Act 1966*NOTICE OF RECEIPT OF APPLICATIONS FOR LICENCES UNDER THE PROVISIONS OF  
THE PRIVATE AGENTS ACT 1966

The Clerk(s) of the Magistrates' Court(s) as listed hereunder hereby give notice that applications, as under, have been lodged for hearing by the said Court(s) on the date(s) specified.

Any person desiring to object to any of such applications must—

- (a) lodge with the respective Clerk of the Magistrates' Court a notice in the prescribed form of his objection and of the grounds thereof;
- (b) cause a copy of such notice to be served personally or by post upon the applicant at least three days before the hearing of the application; and
- (c) send or deliver—
  - (i) where the objection is not made by the officer in charge of the police district in which the Court is situated—a copy of the notice to such officer; and
  - (ii) where the objection is not made by the Registrar or Deputy Registrar—a copy to the Registrar.

<i>Full Name of Applicant*</i>	<i>Place of Abode of Applicant or Nominee</i>	<i>Name of Firm or Corporation</i>	<i>Address for Registration</i>	<i>Type of Licence</i>	<i>Date of Hearing</i>
<b>MAGISTRATES' COURT, PRAHRAN</b>					
Barber, Kevin Ashley	34 Benalla St, Broadmeadows	Mayne Nickless	390 St. Kilda Rd, Melbourne	Watchman	13.8.87
Bennett, Richard Douglas	5/77 Wetherby Rd, Doncaster	"	" "	"	"
Bingham, Craig Stephen	6 Dunsford St, Lancefield	"	" "	"	"
Bradley, Robert William	6 O'Neill Ave, Hoppers Crossing	"	" "	"	"
Chesterman, Donald Ian	1/3 Trevelan St, Blackburn	Alef Security	271A Carlisle St, Balaclava	"	"
Clark, Gregory John	12 Spring St, Preston	Mayne Nickless	390 St. Kilda Rd, Melbourne	"	"
Divers, Hugh	17 Murphy St, Altona	"	" "	"	"
Gardner, Kim Yvette	9 Worthing Crt, Mulgrave	Alef Security	271A Carlisle St, Balaclava	"	"
Herbert, Colin William	1/30 Aberdeen St, Reservoir	Mayne Nickless	390 St. Kilda Rd, Melbourne	"	"
Hunter, Alan James	4 Sherman St, Forest Hill	"	" "	"	"
Irving, Mark Andrew	1-15 Beauty Gully Rd, Warrandyte	"	" "	"	"
Johnstone, Ian Douglas	15 Gladstone Pde, Glenroy	"	" "	"	"
Kellett, Russell Charles	14 Goden Gve, Ringwood	"	" "	"	"
Patterson, Brian Robert	12 Karloo Cl, Epping	"	" "	"	"

\*Or in the case of a firm or corporation, of the Nominee

## PRIVATE AGENTS—continued

Full Name of Applicant*	Place of Abode of Applicant or Nominee	Name of Firm or Corporation	Address for Registration	Type of Licence	Date of Hearing
Rounds, Lawrence	1 Glenelg Ct, Melton South	"	" "	"	"
Scott, Anthony Robert	491 Watergate Rd, West Heidelberg	"	" "	"	"
Scott, David John	37 Robin Ave, Norlane	"	" "	"	"
Wulf, Karl Heinz	18/10 Mitford St, St. Kilda	"	" "	"	"
Dated at Prahran, 14 July 1987 Clerk of Petty Sessions					
MAGISTRATES' COURT, SUNSHINE					
Sheekelton, Garry John	12/96 Glass St, Essendon		174 Ashley St, Maidstone	Watchman	21.8.87
Dated at Sunshine, 20 July 1987 R. NIEMER, Clerk of the Magistrates' Court					
MAGISTRATES' COURT, CAMBERWELL					
Hacche, Paul Philip Gareth	22 Armstrong Rd, Seaford	Loss Assessors Vic	1st Floor, 143 Auburn Rd, Auburn	Inquiry Agent	12.8.87
Dated at Camberwell, 10 July 1987 Clerk of the Magistrates' Court					
MAGISTRATES' COURT, PORT MELBOURNE					
Cosson, Steven Andrew	127 Woods St, Newport	Armaguard	152 Turner St, Port Melbourne	Watchman	20.8.87
Ciminelli, Domenic	78 Lothian St, North Melbourne	"	" "	"	"
Galea, Andrew	11 Harrington St, Altona	"	" "	"	"
Anthony Phillip Gill, Malcolm Andrew	220 Kooyong Rd, Caulfield	"	" "	"	"
Jarvis, Albert Joseph	55 Ellerina Rd, Dromana	"	" "	"	"
La Rocca, Santo	1A Birdwood St, Essendon	"	" "	"	"
Pridham, Anthony Robert	77 Manningham St, Parkville	"	" "	"	"
Dated at Port Melbourne, 21 July 1987 B. THIELE, Clerk of the Magistrates' Court					
MAGISTRATES' COURT, TRARALGON					
Kennedy, Neville Geoffrey	3 Phillip St, Traralgon		8 Kay St, Traralgon	Watchman	28.8.87
Dated at Traralgon, 22 July 1987 H. WOODROFFE, Clerk of the Magistrates' Court					

\*Or in the case of a firm or corporation, of the Nominee

## PRIVATE AGENTS—continued

Full Name of Applicant*	Place of Abode of Applicant or Nominee	Name of Firm or Corporation	Address for Registration	Type of Licence	Date of Hearing
<b>MAGISTRATES' COURT, WERRIBEE</b>					
Davies, John Reynolds	2 Sandpiper St, Werribee		2 Sandpiper St, Werribee	Guard Agent	3.9.87
Dated at Werribee, 21 July 1987 Clerk of the Magistrates' Court					
<b>MAGISTRATES' COURT, MELBOURNE</b>					
Watson, Andrens Raymond	16 Wackett St, Laverton	Wormald Security	87 Racecourse Rd, North Melbourne	Watchman	21.7.87
Bagnato, Joseph	52 Blyth St, Brunswick	"	"	"	"
Brown, Patrick Noel	6/11 Guarajong St, Glenroy	"	"	"	"
Cleary, Brian Maurice Graeme	5 Joffre St, Croydon	"	"	"	"
Fairest, James Arthur	56 Cambden Park Pde, Ferntree Gully	"	"	"	"
Gough, Jacqueline Valerie	1 Herbert Cres, Sunbury	"	"	"	"
Houlinan, Mark Anthony	17 Smeaton Ave, Broadmeadows	"	"	"	"
Mazza, Sam	97 Pearson St, West Brunswick	"	"	"	"
Rose, Gregory Alen	4 Oppy Cres, Hoppers Crossing	"	"	"	"
Dated at Melbourne, 21 July 1987 Clerk of the Magistrates' Court					
<b>MAGISTRATES' COURT, MELBOURNE</b>					
Nikolic, Douglas	214 Gladesville Bvd, Patterson Lakes	T.N.T. Security	54 Racecourse Rd, North Melbourne	Watchman	22.7.87
Dated at Melbourne, 22 July 1987 Clerk of the Magistrates' Court					
<b>MAGISTRATES' COURT, DANDENONG</b>					
Froelich, Denis Vincent	"Nindoo" Lot 1 Pearcedale Rd, Pearcedale		"Nindoo" Lot 1 Pearcedale Rd, Pearcedale	Inquiry Agent	14.8.87
Dated at Dandenong, 21 July 1987 G. EBERT, Clerk of the Magistrates' Court					
<b>MAGISTRATES' COURT, SPRINGVALE</b>					
Ranyard, Lynne Alexandra	16 Canopus Dve, East Doncaster		23 Chapel St, Glen Waverley	Watchman	16.8.87
Dated at Springvale, 16 July 1987 M. BOURKE, Clerk of the Magistrates' Court					

\*Or in the case of a firm or corporation, of the Nominee



## PRIVATE AGENTS—continued

<i>Full Name of Applicant*</i>	<i>Place of Abode of Applicant or Nominee</i>	<i>Name of Firm or Corporation</i>	<i>Address for Registration</i>	<i>Type of Licence</i>	<i>Date of Hearing</i>
<b>MAGISTRATES' COURT, WILLIAMSTOWN</b>					
Proksa, Antony	2/277 Nicholson St, Footscray		2/277 Nicholson St, Footscray	Inquiry Agent	20.8.87
Proksa, Antony	2/277 Nicholson St, Footscray		2/277 Nicholson St, Footscray	Process Server	"
Dated at Williamstown, 16 July 1987 Clerk of the Magistrates' Court					
<b>MAGISTRATES' COURT, BROADMEADOWS</b>					
Mulroney, Kevin	7 Danaher Ave, Wallan		Cookes Rd, Mernda	Watchman	13.8.87
Dated at Broadmeadows, 17 July 1987 Clerk of the Magistrates' Court					
<b>MAGISTRATES' COURT, HEIDELBERG</b>					
Stewart, Philip Arthur	28A Hazel Dve, Lower Templestowe		28A Hazel Dve, Lower Templestowe	Process Server	12.8.87
Dated at Heidelberg, 23 July 1987 R. COOK, Clerk of the Magistrates' Court					
<b>MAGISTRATES' COURT, MELBOURNE</b>					
Richards, Susan Anne	478 St. Kilda Rd, Melbourne	T.N.T. Security	54 Racecourse Rd, North Melbourne	Watchman	22.7.87
Britt, Mark Robert	2 Dight St, Collingwood	Mark Robert Britt	2 Dight St, Collingwood	Guard Agent	23.7.87
Dated at Melbourne, 23 July 1987 Clerk of the Magistrates' Court					
<b>MAGISTRATES' COURT, WERRIBEE</b>					
Lee, David John	Unit 8, 46 Plummer Rd, Mentone	Werribee Armed Escort and Security Service Co. Pty Ltd.	9 Stradbroke Way, Werribee	Watchman	20.8.87
Dated at Werribee, 22 July 1987 I. J. SIMMONS, Clerk of the Magistrates' Court					
<b>MAGISTRATES' COURT, SUNSHINE</b>					
White, Kevin James	30 Iluka Dve, Werribee		390 St. Kilda Rd, Melbourne	Watchman	27.8.87
Dated at Sunshine, 27 July 1987 R. A. NIEMER, Clerk of the Magistrates' Court					

\*Or in the case of a firm or corporation, of the Nominee

## PRIVATE AGENTS—continued

Full Name of Applicant*	Place of Abode of Applicant or Nominee	Name of Firm or Corporation	Address for Registration	Type of Licence	Date of Hearing
<b>MAGISTRATES' COURT, TRARALGON</b>					
Miller, Ronald Frederick	4/34 Gordon St, Traralgon		8 Kay St, Traralgon	Watchman	28.8.87
Dated at Traralgon, 27 July 1987 H. WOODROFFE, Clerk of the Magistrates' Court					
<b>MAGISTRATES' COURT, PRESTON</b>					
Calderaro, Joseph	2 Northumberland Dve, Epping		Office No. 7, 294 High St, Preston	Watchman	17.8.87
Dated at Preston, 21 July 1987 R. McHUGH, Clerk of the Magistrates' Court					
<b>MAGISTRATES' COURT, SWAN HILL</b>					
Monaghan, Colin Leslie	Nyah Rd, Swan Hill		103 Badger Creek Rd, Healesville	Watchman	20.8.87
Dated at Swan Hill, 20 July 1987 J. G. SHIELS, Clerk of the Magistrates' Court					
<b>MAGISTRATES' COURT, WODONGA</b>					
Stanford, Gerard Anthony	Coyles Rd, Wodonga		390 St. Kilda Rd, Melbourne	Watchman	18.8.87
Dated at Wodonga, 27 July 1987 P. A. McCANN, Clerk of the Magistrates' Court					

\*Or in the case of a firm or corporation, of the Nominee

*Town and Country Planning Act 1961*  
**MELBOURNE METROPOLITAN  
 PLANNING SCHEME**  
 Amendment No. 472  
 Notice of Amendment

In pursuance of the powers conferred by the *Town and Country Planning Act 1961*, the Governor in Council on 21 July 1987, amended the abovementioned scheme in respect of the municipal district of the City of Melbourne and for which the Minister for Planning and Environment is the Responsible Authority.

The amendment comes into operation on the date this notice is published in the *Government Gazette*.

The amendment includes an ordinance amendment to vary the provisions applying to the Comprehensive Development zone No. 6, including the Concept Plan and Building Envelope Plan, regarding the St. Nicholas site, Rathdowne Street, Carlton.

A copy of the documents may be inspected free of charge, during office hours, at the office of the Ministry for Planning and Environment, The Olderfleet Buildings, 477 Collins Street, Melbourne.

DAVID YENCKEN  
 Secretary for Planning and Environment

*Town and Country Planning Act 1961*  
**MELBOURNE METROPOLITAN  
 PLANNING SCHEME**  
 Amendment No. 429 Part I  
 Notice of Approval

In pursuance of the powers conferred by the *Town and Country Planning Act 1961*, the Governor in Council on 21 July 1987, approved the abovementioned scheme for which the Minister for Planning and Environment is the responsible authority.

The scheme comes into operation on the date this notice is published in the *Government Gazette*.

The scheme includes 16 routine rezonings/ordinance amendments which affect various parcels of land throughout the metropolitan area.

A copy of the documents may be inspected free of charge, during office hours, at the office of the Ministry for Planning and Environment, The Olderfleet Buildings, 477 Collins Street, Melbourne.

DAVID YENCKEN  
Secretary for Planning and Environment

**SHIRE OF DIMBOOLA**  
Road Deviation

Pursuant to the provisions of sections 522 and 526 of the *Local Government Act 1958*, the Council of the Shire of Dimboola hereby directs that the land in the Parish of Tarranyurk indicated by hatching on the plan hereunder which has been purchased, taken or acquired by it shall be a public highway on and from the date of publication of this order in the *Government Gazette* in lieu of the land indicated by cross-hatching on the said plan.

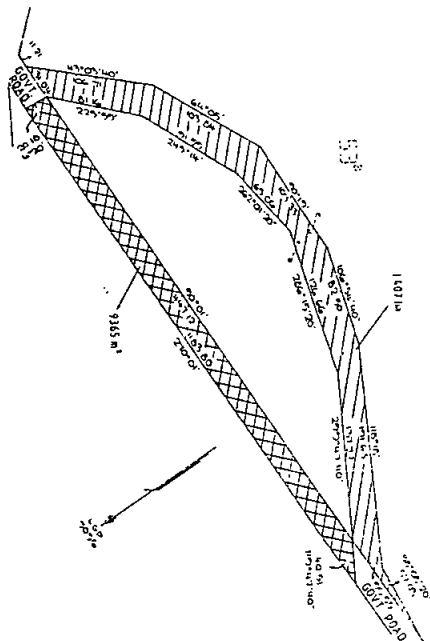

The Common Seal of the President, Councillors and Ratepayers of the Shire of Dimboola was hereunto affixed on 17 June 1987 in the presence of—

K. G. SLEEP, Shire President  
G. PUMPA, Councillor  
M. B. MOLONEY, Shire Secretary

Confirmed by the Governor in Council, 21 July 1987—L. A. FISHER, Acting Clerk of the Executive Council

*Town and Country Planning Act 1961*  
**SHIRE OF KILMORE PLANNING SCHEME**  
Amendment No. 67  
Notice of Approval

In pursuance of the powers conferred by the *Town and Country Planning Act 1961*, the Governor in Council on 21 July 1987, amended the abovementioned scheme in respect of the municipal district of the Shire of Kilmore and for which the Shire of Kilmore is the responsible authority.

The scheme comes into operation on the date this notice is published in the *Government Gazette*.

The scheme includes the rezoning of Lots 1 and 2, LP 89322, Parish of Wallan Wallan, situated on the north-east corner of Duke and Windham Streets, Wallan, from Rural A1 to Residential Development zone.

A copy of the documents may be inspected free of charge, during office hours, at the office of the Ministry for Planning and Environment, The Olderfleet Buildings, 477 Collins Street, Melbourne, and at the office of the Shire of Kilmore, Civic Centre, Kilmore.

DAVID YENCKEN  
Secretary for Planning and Environment

*Town and Country Planning Act 1961*  
**MELBOURNE METROPOLITAN PLANNING SCHEME**  
Amendment No. 454  
Notice of Amendment

In pursuance of the powers conferred by the *Town and Country Planning Act 1961*, the Governor in Council on 21 July 1987, amended the abovementioned scheme in respect of the municipal district of the City of Footscray and for which the Minister for Planning and Environment is the responsible authority.

The amendment comes into operation on the date this notice is published in the *Government Gazette*.

2002 G 29 29 July 1987

Victoria Government Gazette

The amendment includes the rezoning of land in Josephs Road, Footscray, from a Railway Reservation to General Industrial.

A copy of the documents may be inspected free of charge, during office hours, at the office of the Ministry for Planning and Environment, The Olderfleet Buildings, 477 Collins Street, Melbourne, and at the office of the responsible authority.

DAVID YENCKEN  
Secretary for Planning and Environment

*Town and Country Planning Act 1961*  
GEELONG REGIONAL PLANNING  
SCHEME

Amendment No. 179  
Notice of Approval

In pursuance of the powers conferred by the *Town and Country Planning Act 1961*, the Governor in Council on 21 July 1987, approved the abovementioned scheme in respect of the municipal district of the City of Geelong and for which the Geelong Regional Commission is the responsible authority.

The scheme comes into operation on the date this notice is published in the *Government Gazette*.

The scheme includes the deletion of the "Land Liable to Flooding" overlay from land in Barwon Road, Breakwater.

A copy of the documents may be inspected free of charge, during office hours, at the office of the Ministry for Planning and Environment, The Olderfleet Buildings, 477 Collins Street, Melbourne, and at the office of the responsible authority, the Geelong Regional Commission, on the corner of Little Malop and Fenwick Streets, Geelong.

DAVID YENCKEN  
Secretary for Planning and Environment

*Town and Country Planning Act 1961*  
TOWN OF BAIRNSDALE PLANNING  
SCHEME

Amendment No. 59  
Notice of Amendment

In pursuance of the powers conferred by the *Town and Country Planning Act 1961*, the Governor in Council on 21 July 1987, amended the abovementioned scheme in respect of the municipal district of the Town of Bairnsdale and for which the Town of Bairnsdale is the responsible authority.

The amendment includes an ordinance amendment that includes several zones referred to on the Planning Scheme Maps in the relevant clauses.

A copy of the documents may be inspected free of charge, during office hours, at the office of the Ministry for Planning and Environment, The Olderfleet Buildings, 477 Collins Street, Melbourne, and at the office of the responsible authority, the Town of Bairnsdale, Town Offices, Pearson Street, Bairnsdale.

DAVID YENCKEN  
Secretary for Planning and Environment

*Town and Country Planning Act 1961*  
SHIRE OF TAMBO (BALANCE OF SHIRE)  
Planning Scheme Interim Development Order  
Amendment No. 9

Notice of Approval

In pursuance of the powers conferred by the *Town and Country Planning Act 1961*, the Governor in Council on 21 July 1987, approved the abovementioned scheme in respect of the municipal district of the Shire of Tambo and for which the Shire of Tambo is the responsible authority.

The scheme comes into operation on the date this notice is published in the *Government Gazette*.

The scheme includes amending the Ordinance to enable Council to consider applications for extractive industry within the Rural A, Rural B and Township zones.

A copy of the documents may be inspected free of charge, during office hours, at the office of the Ministry for Planning and Environment, The Olderfleet Buildings, 477 Collins Street, Melbourne and at the office of the responsible authority, Shire of Tambo, 51 Main Street, Bruthen.

DAVID YENCKEN  
Secretary for Planning and Environment

*Town and Country Planning Act 1961*  
MELBOURNE METROPOLITAN  
PLANNING SCHEME

Notice that a Planning Scheme has been  
Prepared and is Available for Inspection  
Amending Scheme No. 471

Notice is hereby given that the Minister for Planning and Environment in pursuance of his powers under the *Town and Country Planning Act 1961*, has prepared a Planning Scheme amendment which proposes the reservation of land and modifications to the Planning Scheme

Ordinance to facilitate the establishment of the proposed Nunawading Train Stabling and Maintenance Depot, in the City of Nunawading.

A copy of the Amending Scheme will be deposited at the offices of the Ministry for Planning and Environment, The Olderfleet Buildings, 477 Collins Street, Melbourne, and the offices of the City of Nunawading, Municipal Offices, 379-397 Whitehorse Road, Nunawading, from 29 July 1987 to 30 October 1987 and will be open for inspection during office hours by any person free of charge.

Any persons affected by the Amending Scheme are required to set forth in writing any submissions they may wish to make with respect to the Amending Scheme, addressed to the Minister for Planning and Environment, Attention Chief Assessment Officer, 4th Floor, The Olderfleet Buildings, 477 Collins Street, Melbourne, 3000, by 30 October 1987 and to state whether they wish to be heard in respect of their submissions.

Dated 28 July 1987

DAVID YENCKEN

Secretary for Planning and Environment

Note: An Environment Effects Statement in respect to the proposed amendment has been prepared on behalf of the Metropolitan Transit Authority and is being exhibited concurrently with the Planning Scheme amendment.

A single submission covering the Environment Effects Statement and the Planning Scheme amendment will suffice.

## VICTORIA

### ACT 391—Second Schedule

A statement of trusts having been submitted by the head or authorised representative of the denomination known as The Presbyterian Church of Victoria pursuant to the provisions of the Act to provide for the abolition of State Aid to Religion for allowance of His Excellency the Governor of Victoria and the following is the form in which such statement of trusts is allowed.

#### Statement of Trusts

*Description of Land*—Site set apart for Free Presbyterians Church purposes 8094 square metres, Parish of Duneed, County of Grant being Crown Allotment L5 Section 21. Commencing at the south-eastern angle of the site being a point bearing 0°00' 20-12 metres from the north-eastern angle of Crown Allotment P Section 21, bounded thence by a road bearing 270°00' 100-58 metres; by lines bearing 0°00' 80-47 metres, 90°00' 100-58 metres and thence by a road bearing 180°00' 80-47 metres to the point of commencement.

*Name of Trustees*—The Presbyterian Church of Victoria Trusts Corporation.

*Powers of Disposition*—Presbyterian Trusts Act 1890 as amended by the Presbyterian Trusts (Common Fund) Act 1965 and the Presbyterian Church of Australia Act 1971.

*Purposes to which Proceeds of Disposition are to be Applied*—The Presbyterian Church of Victoria.

As Witness the Hand of the Governor of the State of Victoria this 21 July 1987.

J. DAVIS McCAUGHEY

Governor of the State of Victoria

I hereby give notice that on 10 July 1987, the Public Trustee filed Elections to Administer the following deceased persons' estates in accordance with section 17 of the Public Trustee Act 1958:

Harris, James, late of Mount Egerton Road, Elaine, pensioner, died 22 February 1987.

Harrop, Elsie, but late of Bendigo Home and Hospital for the Aged, Bendigo, widow, died 25 September 1986.

Tempany, Muriel Elizabeth, formerly of 34 Gillbank Street, Reservoir, but late of Flat 4, 41 Cumming Street, West Brunswick, married woman, died 6 February 1987.

Dated 22 July 1987

W. J. KILPATRICK

Public Trustee

Creditors, next of kin and others having claims against the estate of any of the under-mentioned deceased persons are required to send particulars of their claims to the Public Trustee, 168 Exhibition Street, Melbourne, Vic. 3000, the personal representative, on or before 1 October 1987 after which date the Public Trustee may convey or distribute the assets having regard only to the claims of which the Public Trustee then has notice:

Harris, James, late of Mount Egerton Road, Elaine, pensioner, died 22 February 1987.

Harrop, Elsie, but late of Bendigo Home and Hospital for the Aged, Bendigo, widow, died 25 September 1986.

Hughes, Samuel Harold, also known as Samuel Hughes, late of 48 Archibald Street, Lyncham, A.C.T., retired insurance agent, died 26 February 1987.

Johannesen, Chloris Hilda, but late of 35 Hume Street, Armadale, widow, died 11 April 1987.

Jones, William Christmas Evan, late of 85 Fitzwilliam Street, Kew, retired school teacher, died 16 April 1987.

Kmita, Stanislaw, also known as Stanley Kmita, late of 5 Carlyle Street, Ashwood, retired knitter, died 24 August 1985.

Mills, Lillian, formerly of Flat 1, 31 Tourello Avenue, East Hawthorn, but late of Holly Dale Lodge, 37 Burke Road, East Malvern, home duties, died 22 April 1987.

O'Connell, Beryl Frances, but late of St. Leeor Private Nursing Home, 31 Thanet Street, Malvern, pensioner, died 10 March 1987.

Tempany, Muriel Elizabeth, formerly of 34 Gillbank Street, Reservoir, but late of Flat 4, 41 Cumming Street, West Brunswick, married woman, died 6 February 1987.

W. J. KILPATRICK  
Public Trustee

*Education Act 1958*

**NOTICE OF THE MAKING OF AN ORDER UNDER SECTION 12D (3) OF THE ACT**

Pursuant to section 12D of the *Education Act 1958*, I hereby give notice that an Order of the Governor in Council was made on 21 July 1987 under sub-section (3) of the said Act amending certain provisions relating to the Regional Boards of Education.

IAN CATHIE  
Minister for Education

**RURAL WATER COMMISSION OF VICTORIA**

**Designation of 1% Probability Flood Levels City of Castlemaine**

Pursuant to section 37A of the *Drainage of Land Act 1975* the Rural Water Commission, as the Drainage Authority, hereby designates the flood levels as more particularly described on Plan Nos. 147474 (Campbells and Wattle Creeks) and 147496 (Forest and Moonlight Creeks) lodged in the Plan Room of the Rural Water Commission, 590 Orrong Road, Armadale, and its offices at Bendigo and also at the Municipal Offices of the City of Castlemaine.

Subject to the provision of section 37A (4) of the *Drainage of Land Act 1975*, any person who feels aggrieved by the designation of flood levels may within one month of the last publication of this notice in *Castlemaine Mail* on 31 July 1987, appeal to the Minister for Water Resources, setting out the ground of appeal against that designation.

Dated 22 July 1987

R. C. SKINNER  
Acting General Manager

*Industrial Relations Act 1979*

**FIBROUS PLASTERERS CONCILIATION AND ARBITRATION BOARD**

Notice is hereby given that an application has been lodged by the Victorian Plaster Industry Workers' Union for an extension of the jurisdiction of the Fibrous Plasterers Conciliation and Arbitration Board so that it applies to the trades of fixing and finishing of composite boards where a plaster finish is required.

Notice is also given that this matter is listed for hearing before the Industrial Relations Commission of Victoria in Full Session at 10.30 a.m. on Thursday, 27 August 1987, in Hearing Room No. 1, Level 18, Nauru House, 80 Collins Street, Melbourne.

A. S. DOWLING  
Deputy Registrar

Industrial Relations Commission of Victoria

*Industrial Relations Act 1979*

**INDUSTRIAL RELATIONS COMMISSION OF VICTORIA**

Application for a Declaration as to the True Intent and Effect of Clause 6, Higher Duties, of the Registered Nurses Award No. 1 of 1986

Notice is hereby given that an application has been made by the Royal Australian Nursing Federation (Victorian Branch) under section 21 (2) of the *Industrial Relations Act 1979* for a declaration as to the true intent and effect of Clause 6, Higher Duties, of the Registered Nurses Award No. 1 of 1986.

Notice is also given that this matter is listed for mention before the Industrial Relations Commission of Victoria in Court Session at 10.00 a.m. Thursday, 30 July 1987 in Hearing Room No. 1, Level 18, Nauru House, 80 Collins Street, Melbourne.

A. S. DOWLING  
Deputy Registrar

Industrial Relations Commission of Victoria

**ASSOCIATIONS INCORPORATION ACT 1981**

Notice is hereby given that in pursuance of sub-section 10 (4) of the *Associations Incorporation Act 1981* a certificate of incorporation was granted to Epirotic Philanthropic Society of Australia "Dodoni" on 8 July 1987.

R. C. TREVETHAN  
Registrar of Incorporated Associations

**ASSOCIATIONS INCORPORATION ACT  
1981**

Notice is hereby given that in pursuance of sub-section 10 (4) of the *Associations Incorporation Act* 1981 a certificate of incorporation was granted to Western Region Council for Social Development on 8 July 1987.

**R. C. TREVETHAN**  
Registrar of Incorporated Associations

**ASSOCIATIONS INCORPORATION ACT  
1981**

Notice is hereby given that in pursuance of sub-section 10 (4) of the *Associations Incorporation Act* 1981 a certificate of incorporation was granted to Burumbeep Ski Club Co-operative Limited on 17 July 1987.

**R. C. TREVETHAN**  
Registrar of Incorporated Associations

*Transport Act* 1983

**ROAD TRAFFIC AUTHORITY**

**Commercial Passenger Vehicle Applications**

Notice is hereby given that the following applications will be considered by the Road Traffic Authority on 1 September 1987.

Notice of any objections should be forwarded to reach the Manager, Vehicle Licensing Branch or any Regional Office of the Road Traffic Authority not later than 26 August 1987.

It will not be necessary for interested parties to appear on the hearing date specified, unless advised in writing by the Authority.

Notification of the date for consideration of applications which are objected to and which require determination by the Road Transport Licensing Tribunal will be published by further notice in this Gazette.

**P. Dockery, Noble Park.** Application to license one commercial passenger vehicle to be purchased with seating capacity for 22 passengers to operate as a Metropolitan special service omnibus.

*Note:* The vehicle to be licensed would hold a minimum 2 star rating for charter purposes.

**B. G. & J. C. Edwards, Bruthen.** Application for variation of conditions of licence SV 694 which authorise tours of 1 to 7 days duration from Bairnsdale or Bruthen to delete the existing fare structure and instead charge fares by agreement with the hirer.

**Gladmont Pty. Ltd., Moonee Ponds.** Application to license ten commercial passenger vehicles to be purchased in respect of 1956-1987 Bentley sedans, 1956-1987 Rolls Royce sedans, 1981-1987 Mercedes Benz sedans, 1984-1987

BMW sedans, 1984-1987 Volvo sedans and 1985-1987 Jaguar sedans, each with seating capacity for 5 passengers to operate as metropolitan hire cars from a depot situated within a 10 km radius of the Melbourne G.P.O.

**F. Holmes, Montrose.** Application to license two commercial passenger vehicles to be purchased in respect of two 1970 Rolls Royce sedans, each with seating capacity for 4 passengers to operate as special purpose vehicles from 27 Lilydale-Montrose Road, Montrose for the carriage of passengers for wedding parties.

**Seymour Passenger Service Pty. Ltd., Seymour.** Application to license one commercial passenger vehicle with seating capacity for 19 passengers to operate a service for the carriage of school children to the exclusion of all other passengers excepting duly authorised teachers between Kilmore and Romsey.

*Note:* The service to operate under contract to St. Patricks Parish School.

**Seymour Passenger Service Pty. Ltd., Seymour.** Application to license one commercial passenger vehicle with seating capacity for 22 passengers to operate a service for the carriage of school children to the exclusion of all other passengers excepting duly authorised teachers between Euroa and Seymour.

*Note:* The service to operate under contract to St. Patricks Parish School.

**Shuttlebus Ballarat Pty. Ltd., Ballarat.** Application for variation of CO licence conditions which authorise various route service operations to operate in substitution for but not in addition to existing TO licences in the name of the applicant.

Dated 29 July 1987

**M. KENT**  
Group Manager  
Vehicle Licensing and Regulation Strategies

**ROAD TRAFFIC AUTHORITY**

*Transport Act* 1983

**Determination of Fees**

In accordance with section 147b of the *Transport Act* 1983 the Road Traffic Authority has obtained the approval of the Minister for Transport for the following fee which the Road Traffic Authority has determined as the fee payable under section 147a (1) of that Act:

Annual fee for a licence to operate a commercial passenger vehicle classified by the Authority as a taxi-cab—\$300.

**MICHAEL J. ROUX**  
Chairman and Managing Director  
Road Traffic Authority

*Health Act 1958*

**SUPPLEMENT TO THE REGISTER OF CONTRACEPTIVES PUBLISHED IN THE  
Government Gazette IN ACCORDANCE WITH THE PROVISIONS OF SECTION 270H (5) OF  
THE Health Act 1958.**

<i>Serial No.</i>	<i>Date of Registration</i>	<i>Distinctive Name</i>	<i>Name and Address of Applicant</i>
C237	1.7.87	Ansell Lifestyles Ultrasure Condoms (12 pack)	Ansell International, South Gippsland Highway, Dandenong Vic. 3175
C238	1.7.87	Ansell Lifestyles Ultrasure Condoms (3 pack)	Ansell International, South Gippsland Highway, Dandenong Vic. 3175

G. J. ROUCH  
Health Department, Victoria

*Co-operation Act 1981*

BEAUMARIS HIGH SCHOOL NO. 2 CO-OPERATIVE LTD.  
NORTH BOX HILL TENNIS CLUB CO-OPERATIVE LIMITED  
HILLVIEW COLLEGE CO-OPERATIVE LIMITED  
KANGAROO FLAT PRIMARY SCHOOL CO-OPERATIVE LIMITED

Notice is hereby given in pursuance of section 192 (8) of the *Co-operation Act 1981* and section 459 (2) of the Companies (Victoria) Code, that, at the expiration of three months from the date hereof, the names of the aforementioned societies will, unless cause is shown to the contrary, be struck off the register and the societies will be dissolved.

Dated at Melbourne 10 June 1987

DAN HENRY  
Acting Deputy Registrar of Co-operative Societies

*Co-operation Act 1981*

**NOTICE OF DISSOLUTION OF SOCIETIES**  
Fiery Creek Co-operative Limited  
Laverton Bowling Club Co-operative Limited  
Mirboo North Primary School Co-operative Limited

Notice is hereby given that I have this day registered the dissolution of the above-named societies and cancelled their registration under the above-named Act.

Dated at Melbourne 12 June 1987

DAN HENRY  
Acting Deputy Registrar of Co-operative Societies

*Co-operation Act 1981***CHANGE OF NAME OF A SOCIETY**

Notice is hereby given that Tirhatuan Park Golf Club Co-operative Ltd. which was incorporated as a Community Advancement Society under the above-named Act on 18 October 1985, has registered a change of its name and is now incorporated under the name of Tirhatuan Park Co-operative Ltd. under the said Act.

Dated at Melbourne 10 July 1987.

DAN HENRY  
Acting Deputy Registrar of Co-operative Societies

*Co-operative Housing Societies Act 1958***NOTICE OF DISSOLUTION OF SOCIETIES**

A.N.A Co-operative Housing Society (No. 5) Limited

A.N.A. Co-operative Housing Society (No. 7) Limited

A.N.A Co-operative Housing Society (No. 10) Limited

Barwon (No. 1) Co-operative Housing Society Limited

Benalla No. 6 Co-operative Housing Society Limited

Corio and Moorpanyal (No. 4) Co-operative Housing Society Limited

Corio and Moorpanyal (No. 5) Co-operative Housing Society Limited

Geelong Citizens Co-operative Housing Society No. 6 Limited

Geelong Citizens Co-operative Housing Society No. 10 Limited

Greater Moorabbin (No. 4) Co-operative Housing Society Limited



Horsham No. 2 Co-operative Housing Society Limited  
 Minerva Co-operative Housing Society Limited  
 Moorabool No. 4 Co-operative Housing Society Limited  
 Oakleigh (No. 10) Co-operative Housing Society Limited  
 Ocean Grove and District Co-operative Housing Society Limited

Notice is hereby given that I have this day registered the dissolution of the above-named societies and cancelled their registration under the above-named Act.

Dated at Melbourne 24 June 1987

P. J. ROGAN  
 Deputy Registrar of Co-operative Housing Societies

*Police Offences Act 1958, No. 6337*  
 DIVISION 1A—STATE CLASSIFICATION  
 OF PUBLICATIONS BOARD

Take note that the State Classification of Publications Board has classified the following publications in accordance with the provisions of section 180H (1) of the *Police Offences Act 1958*.

Each publication shall be subject to the following restrictions:

- (a) It shall not be offered for sale, sold or delivered to any person under the age of 18 years;
- (b) It shall not be made available for inspection or perusal by any person under the age of 18 years.

<i>Title</i>	<i>Distributor</i>
Fiesta—Vol. 21 No. 8	Gordon & Gotch Ltd.
*Genesis* Girls/ Girls—Fall 1987	Gordon & Gotch Ltd.
Penthouse Variations— September 1987	Gordon & Gotch Ltd.

R. V. DOOLEY  
 Acting Secretary  
 State Classification of Publications Board

*Police Offences Act 1958, No. 6337*  
 DIVISION 1A—STATE CLASSIFICATION  
 OF PUBLICATIONS BOARD

Take note that the State Classification of Publications Board has classified the following publications in accordance with the provisions of section 180H (1) of the *Police Offences Act 1958*.

Each publication shall be subject to the following restrictions:

- (a) It shall not be offered for sale, sold or delivered to any person under the age of 18 years;
- (b) It shall not be made available for inspection or perusal by any person under the age of 18 years;
- (c) It shall not be exhibited or displayed in any place to which persons under the age of 18 years have access or so that it is visible from any such place.

<i>Title</i>	<i>Distributor</i>
Erotic X-Film Guide—October 1987—Vol. 5 No. 6	Gordon & Gotch Ltd.
Family Letters— November 1987—Vol. 4 No. 7	Gordon & Gotch Ltd.
X-Letters—October 1987—Vol. 4 No. 7	Gordon & Gotch Ltd.

R. V. DOOLEY  
 Acting Secretary

State Classification of Publications Board

Ministerial Council for Companies and  
 Securities

FUTURES INDUSTRY ACT 1986 AND  
 CORRESPONDING LAWS OF THE STATES  
 OF NEW SOUTH WALES AND VICTORIA  
 Declaration under sub-section 45 (2)

Pursuant to sub-section 45 (2) of the *Futures Industry Act 1986* and the corresponding laws of the States of New South Wales and Victoria ("the Act") the Ministerial Council for Companies and Securities hereby declares as an exempt futures market the futures market commonly known as the Loco-London Bullion Market for Deferred-Delivery Gold and Silver Contracts which persons who are members of a "relevant organisation" within the meaning of the definition in sub-section 4 (1) of the Act establish, maintain or provide, or assist in establishing, maintaining or providing and who deal in futures contracts which—

- (a) are of a kind which are not ordinarily traded on a futures market of any futures exchange;
- (b) specify that the quantity of gold or silver bullion is not less than 100 troy ounces of gold and 1000 troy ounces of silver per contract unit;
- (c) express the price of the gold or silver bullion in the currency of the United States of America or Australia; and

(d) specify that the grade of gold or silver is not less than 99.5 per centum purity—in that futures market.

Dated at Sydney 1 July 1986

The Honourable T. W. SHEAHAN, MLA  
Attorney-General for New South Wales

Ministerial Council for Companies and Securities

FUTURES INDUSTRY ACT 1986 AND  
CORRESPONDING LAWS OF THE STATES  
OF NEW SOUTH WALES, VICTORIA,  
WESTERN AUSTRALIA, QUEENSLAND  
AND SOUTH AUSTRALIA

Declaration under sub-section 45 (2)

Pursuant to sub-section 45 (2) of the *Futures Industry Act* 1986 and the corresponding laws of the States of New South Wales, Victoria, Western Australia, Queensland and South Australia ("the Act") the Ministerial Council for Companies and Securities hereby declares as an exempt futures market the futures market provided by Macquarie Bank Limited for forward precious metals contracts ("the contracts") on condition that—

- (a) the contracts do not contain the same specifications as contracts traded on a futures market of any futures exchange or recognised futures exchange; and
- (b) the persons with whom the bank enters into the contracts are *bona fide* producers, refiners, merchants or users of precious metals.

Dated at Sydney, 2 February 1987

The Honourable T. W. SHEAHAN, MLA  
Attorney-General for New South Wales  
(For and on behalf of the Ministerial Council  
for Companies and Securities by its duly  
authorised member.)

*Legal Profession Practice Act* 1958

SOLICITORS' (AUDIT AND PRACTISING  
CERTIFICATES) RULES 1987

Pursuant to section 88 of the *Legal Profession Practice Act* 1958 and all other powers thereto enabling, the Council of the Law Institute of Victoria hereby makes the following rules:

1. These rules may be cited as the "Solicitors' (Audit and Practising Certificates) Rules 1987" and shall come into operation on the date on which they are published in the *Government Gazette*.

2. In these rules the Solicitors' (Audit and Practising Certificates) Rules 1985 are called "the Principal Rules".

3. Rule 41 of the Principal Rules is amended as follows:

- (a) In sub-rule 1 there is substituted the year "1988" for the year "1987".
- (b) In paragraph (a) of sub-rule 1, there is substituted the sum of "\$415.00" for the sum of "\$380.00".
- (c) In paragraphs (b) and (c) of sub-rule 1, there is substituted the sum of "\$245.00" for the sum of "\$225.00".

Signed on behalf of the Council of the Law Institute of Victoria.

IAN DUNN, President  
R. J. A. CORNALL, Secretary

I approve the above Rules.

Dated 28 July 1987

JOHN McI. YOUNG  
8086 Chief Justice

FRIENDLY SOCIETIES REGULATIONS  
1987

It is proposed to make regulations entitled *Friendly Societies Regulations 1987* prescribing various matters for the purposes of the *Friendly Societies Act* 1986. That Act is not yet in operation, but is expected to be proclaimed in the near future.

The objectives of the Statutory Rule are to prescribe the forms recoup the costs of providing services under the Act, provide for payment of monies to persons attending for examination under the Act and such other matters as are required or necessary to carry the Act into effect. These objectives are to be achieved so that they balance the deregulatory thrust of the Act with the demands of administrative efficiency.

The statement concludes that the proposed regulations are the most appropriate method available to achieve the objectives, because they provide an appropriate balance between the deregulatory thrust of the Act, the administrative requirements for consistency and certainty and other competing interests. This has been achieved by prescribing a minimum number of forms and restricting fee increases to accord with Government policy.

A copy of the regulatory impact statement may be obtained from the Legal and Policy Division, Corporate Affairs Office, 471 Little Bourke Street, Melbourne 3000.

Comments and submissions are invited from the public and will be received up to 21 days from the publication of this advertisement.

MALCOLM WALTER  
Acting Deputy Commissioner, Legal and Policy

**ECHUCA ABORIGINAL CO-OPERATIVE SOCIETY LTD.**

Notice is hereby given in accordance with section 137 of the *Land Act* 1958 that after the expiration of 14 days from the date of this public notice the Echuca Aboriginal Co-operative Society Ltd. shall be granted a 99 year lease over Crown land described hereunder for commercial purposes:

**Description of Land**

948 m<sup>2</sup> of Crown land on which is situated the old Echuca Court House, being Allotment 8, section 2 located on the corner of Dickson Street and Law Court Place in the Parish of Echuca North, Township of Echuca to the Echuca Aboriginal Co-operative Society Ltd., 541 High Street, Echuca, Victoria 3625.

M. JOHNSON  
Administrator

Echuca Aboriginal Co-operative Society Ltd.

Department of Industry, Technology and  
Resources

**INTENTION TO GRANT A MINING LEASE**  
No. 1112; United and Commercial Holdings Ltd;  
approx 1.5 ha, Parish of Bright.

**MINING LEASES GRANTED**

No. 988; E. L. & M. L. Smith; 5.255 ha, Parish  
of Terrick, Terrick West.

No. 1070; Wedderburn Drilling Co P/L; 13.31  
ha, Parish of Bealiba.

**MINING LEASE RENEWED**

No. 630-2; Australian Plaster P/L; 112.1634 ha,  
Parish of Tyalla and Tutye.

**DEVELOPMENT LEASES GRANTED**

Nos. 230, 232 & 277; Dargo Gold NL; 46.22,  
24.372 and 45.62 ha respectively,  
Parish of Redcastle.

**PROSPECTING AREA LICENCE GRANTED**  
No. 196; Ando Minerals NL; 9.89 ha, Parish of  
Painswick.

**PROSPECTING AREA LICENCES RENEWED**

No. 54-1; R. A. Borchers, B. Cozens & W. Green;  
200 ha, Parish of Brimbonga.

No. 55-1; R. A. Borchers, B. Cozens & W. Green;  
248 ha, Parish of Brimbonga.

**APPLICATIONS FOR RENEWAL OF PROSPECTING AREA LICENCES WITHDRAWN**

Nos. 82-1, 83-1, 84-1 & 89-1; KTM Gold P/L;  
24, 2.79, 8 and 7.4859 has, Parishes  
of Kangeraar and Tchuterr.

**TAILINGS REMOVAL LICENCES GRANTED**

No. 5131; Borough of Sebastopol, to remove  
tailings from the corner of Miles and  
Todd Streets situated in the Parish of  
Ballarat.

No. 5191; Triad Minerals NL; to remove tailings  
located within ML 1302 situated in  
the Parish of Maldon.

No. 5242; R. J., E. R. and C. A. Conboy; to  
remove tailings from the Bracewell  
and James Street Dump situated in  
the Parish of Nerring.

**APPLICATION FOR TAILINGS REMOVAL LICENCE REFUSED**

No. 5194; W. H. Jay and S. F. Reardon; to  
remove tailings from within ML 961  
situated in the Parish of Tongio  
Munjie West.

**TAILINGS REMOVAL LICENCE CANCELLED**

No. 4959; Shire of Ballan, to remove tailings  
from the "Sultana and North Mine  
Dump" situated in the Parish of  
Blackwood.

**TAILINGS TREATMENT LICENCE GRANTED**

No. 261; Tulong Four P/L; approximately 17.9  
ha, Parish of Craigie.

**APPLICATION FOR EXPLORATION LICENCE DECLARED ABANDONED**

No. 1999; Thirty Fourth Shako P/L; 336 km<sup>2</sup>,  
Shire of Tambo.

**EXPLORATION LICENCE EXTENDED**

No. 1451-1; KTM Gold P/L; 37 km<sup>2</sup>, County of  
Kara Kara.

**APPLICATION FOR EXTENSION OF EXPLORATION LICENCE REFUSED**

No. 1445-1; Balmoral Resources NL; 68 km<sup>2</sup>,  
Birchip.

**EXPLORATION LICENCE EXPIRED**

No. 1487; Bendigo Dredging NL; 50.5 km<sup>2</sup>,  
County of Bendigo.

**EXTRACTIVE INDUSTRY LICENCE RENEWED**

No. 1116-1; Oupan Resources P/L; 85.82 ha,  
Shire of Bacchus Marsh.

**EXTRACTIVE INDUSTRY LICENCE ASSIGNED**

No. 1072; From Associated Quarries (Western)  
Pty Ltd to CSR Ltd.

**EXTRACTIVE INDUSTRY LICENCE EXPIRED**

No. 1112; F. T. Whelan; 16.19 ha, Parish of  
Kooweerup East.

**EXTRACTIVE INDUSTRY SEARCH  
PERMIT GRANTED**

No. 122; KBY P/L; approx 640 ha, Parish of  
Wibenduck.

**ROBERT FORDHAM**  
Minister for Industry, Technology and  
Resources

**CORRIGENDUM**

Melbourne Metropolitan Planning Scheme  
Amendment No. 480

*Government Gazette*, No. G28 dated 22 July  
1987 page 1927.

The third paragraph should read as follows:

"The amendment includes an Ordinance  
amendment that makes a detached house the  
subject of siting requirements and Council  
discretion."

**DAVID YENCKEN**  
Secretary for Planning and Environment

**CORRIGENDUM**

Shire of Sherbrooke Interim Development  
Order 1987

*Government Gazette* No. G26 dated 8 July  
1987 page 1807.

The third paragraph should read as follows:

"The Order provides that the use or  
development of any land or the erection,  
construction or carrying out of any buildings or  
works within the Shire, other than in conformity  
with the Order and the Shire of Sherbrooke  
Planning Scheme 1984 (amended), is  
prohibited."

**DAVID YENCKEN**  
Secretary for Planning and Environment

**APPOINTMENTS AND  
RESIGNATIONS**

**APPOINTMENTS**

His Excellency the Governor of the State of  
Victoria by and with the advice of the Executive  
Council thereof has by Order made on 21 July  
1987 been pleased to make the undermentioned  
appointments, viz.:

**Department of Health**

*Trustee of Public Cemeteries*

Gordon Barry ALLAN

Brian BOBBIN and

Jim BUCKLAND

to be Trustees of the Mallacoota Cemetery Trust.

John Edward DELVIN

Adrian Douglas BELL and

John Leonard IBBOTSON

to be Trustees of the Lismore Cemetery Trust.

Peter William DICKINSON

to be a Trustee of the Torrumbarry and Patho  
Cemetery Trust.

John Mervyn NICHOLSON

Kevin Thomas KIRK

Stephen Keith John BOOTH

Vincent Thomas LEY and

Jean MERBACH

to be Trustees of the Tallangatta Cemetery Trust.

All appointments made pursuant to section 3 (1)  
of the *Cemeteries Act* 1958.

**Attorney-General's Department**

*Prosecutor for the Queen*

Elizabeth Helen CURTAIN

to be Prosecutor for the Queen pursuant to  
section 352 of the *Crimes Act* 1958 from 3 August  
1987.

Lance Ivan MARTIN, a Barrister and Solicitor  
of the Supreme Court of Victoria to be a  
Magistrate pursuant to section 7 of the  
*Magistrates' Courts Act* 1971 from 21 July 1987.

Noel Brian PURELL, a Magistrate to be a  
Coroner pursuant to the provisions of the  
*Coroners Act* 1985, section 8, the term of office  
being concurrent with appointment as a  
Magistrate.

Ken MCLAREN, to be a part-time member of  
the Victorian Prison Industries Commission  
pursuant to section 8 (2) (b), *Victorian Prison  
Industries Act* 1983 for a period of 3 years, from  
21 July 1987.

James BEGGS, to be a part-time Member,  
Victorian Prison Industries Commission

pursuant to section 8 (2) (d) (iii) of the *Victorian Prison Industries Commission Act 1983* for a period of 3 years from 21 July 1987.

Department of Labour  
*Acting President of the Industrial Relations Commission*

Brian Donnelly LAWRENCE to be Acting President of the Industrial Relations Commission during the period 13 August 1987 to 25 September 1987 inclusive, or until the return to duty after leave of absence of Keith Douglas Marshall, whichever occurs first.

L. A. FISHER  
Acting Clerk of the Executive Council  
At the Executive Council Chamber  
Melbourne, 21 July 1987

1	Maroondah	Inspector Lawrence Colin Beet, 15803 (from 1.7.87 to 31.7.87)
1	Prahran	Chief Inspector Robert Ian O'Loughlin, 13276 (vice Superintendent Fennessy, 13192)
1	Wimmera	Senior Sergeant Geoffrey Noel Leversha, 13965 (from 28.6.87 to 18.7.87)
1	Wimmera	Chief Inspector Rex John Topp, 12927 (vice Superintendent Campbell, 12127)

Dated 20 July 1987

PAUL DELIANIS  
Deputy Commissioner (Administration)

*Liquor Control Act 1968*  
APPOINTMENT OF LICENSING  
INSPECTORS

In accordance with the authority conferred upon me by section 6 of the *Police Regulation Act 1958*, I, Paul Delianis, Deputy Commissioner of Police, do hereby appoint under sub-section (1) of section 22 of the *Liquor Control Act 1968*, the following Officers of Police as Licensing Inspectors for the Divisions of the Police Districts as shown:

Division	Police Number	District	Rank and Name
1		Central Highlands	Senior Sergeant Robert John Barby, 16049 (from 11.5.87 to 31.8.87)
2		Dandenong	Inspector George Edward Johnson, 15142 (from 19.7.87 to 8.8.87)
2		Dandenong	The appointment of Inspector David Charles Sprague for the period 19.7.87 to 8.8.87 is withdrawn
1		Essendon	Superintendent Alan Keith Porter, 12980 (vice Chief Superintendent Morahan, 11017)
2		Essendon	Chief Inspector Maxwell Castree, 13019 (vice Superintendent Harding, 11079)
1		Malvern	Chief Inspector Keith Charles MacDonald, 12024 (vice Superintendent Petty, 12208)

RESIGNATIONS

His Excellency the Governor of the State of Victoria by and with the advice of the Executive Council thereof has by Orders made on 21 July 1987 accepted the resignations of the persons named hereunder of the offices mentioned, viz.:

Department of Health  
*Trustee of Public Cemetery*

Robert THOMSON  
as Trustee, Tallangatta Cemetery as from 10 April 1987 in accordance with the provisions of section 6 of the *Cemeteries Act 1958*.

Department of Labour  
*Commissioner of the Industrial Relations Commission of Victoria*

Gordon C. RODGERS  
from the position of Commissioner of the Industrial Relations Commission of Victoria, to take effect from 29 August 1987.

L. A. FISHER  
Acting Clerk of the Executive Council  
At the Executive Council Chamber  
Melbourne, 21 July 1987

**ORDERS IN COUNCIL***Melbourne Wholesale Fruit and Vegetable Market Trust Act 1977***APPOINTMENT OF CHAIRPERSON, DEPUTY CHAIRPERSON AND MEMBERS OF THE MELBOURNE WHOLESALE FRUIT AND VEGETABLE MARKET TRUST**

The Governor in Council acting under section 7 of the *Melbourne Wholesale Fruit and Vegetable Market Trust Act 1977* appoints—

Linton Roy Lethlean to be Member and Chairperson;

Daniel Eric Kent to be Member and Deputy Chairperson;

Alan Dykes to be a Member;

Michael Norman Kinsella to be a Member;

Angelo Siragusano to be a Member; and

Santo Antonio Varapodio to be a Member—

of the Melbourne Wholesale Fruit and Vegetable Market Trust for the period ending 30 June 1988.

Dated 21 July 1987

Responsible Minister:

EVAN WALKER

Minister for Agriculture and Rural Affairs

L. A. FISHER

Acting Clerk of the Executive Council

*Crown Land (Reserves) Act 1978***REVOCATION OF TEMPORARY RESERVATIONS**

The Governor in Council under section 10 of the *Crown Land (Reserves) Act 1978* revokes the following temporary reservations:

**CURYO**—The temporary reservation by Order in Council of 14 March 1908 of 7082 square metres of land in section 3, Township of Curyo, Parish of Curyo as a site for a State School—(Rs. 2186).

**MILDURA**—The temporary reservation by Order in Council of 1 March 1960 of 11.74 hectares, more or less, of land in Section B, Parish of Mildura, as a site for Public Park and Public Recreation—(Rs. 7869).

**SPRINGHURST**—The temporary reservation by Order in Council of 9 December 1885 of 29.09 hectares of land in the Township of Springhurst, Parish of Bontherambo, revoked as to part by Order in Council of 26 May 1970 and the temporary reservation by Order in Council of 13 September 1983 of the remaining areas of 27.78

hectares, more or less, of such land for the additional purposes of Public Hall, so far only as the portion containing 4420 square metres as indicated by hatching on plan published in the *Government Gazette* on 1 July 1987—(Rs. 610).

**WODONGA**—The temporary reservation by Order in Council of 22 November 1875 of 4.91 hectares of land east of Crown Allotment 13c, Section 1, Parish of Wodonga, as a site for Quarrying purposes—(Rs. 13227).

**WOORNDOO**—The temporary reservation by Order in Council of 18 May 1869 of 4047 square metres of land in Section 7, Township of Woorndoo as a site for Common School purposes—(Rs. 5767).

**WOORNDOO**—The temporary reservation by Order in Council of 5 July 1869 of 2023 square metres of land in Section 7, Township of Woorndoo for Common School purposes in addition to the site temporarily reserved for those purposes by Order in Council of 18 May 1869—(Rs. 5767).

**WOORNDOO**—The temporary reservation by Order in Council of 27 February 1909 of 2049 square metres of land in Section 7, Township of Woorndoo as a site for a State School in addition to and adjoining the site temporarily reserved for Common School purposes by Orders of 18 May 1869 and 5 July 1869. (Rs. 5767).

Dated 21 July 1987

Responsible Minister:

JOAN E. KIRNER

Minister for Conservation, Forests and Lands

L. A. FISHER

Acting Clerk of the Executive Council

*Crown Land (Reserves) Act 1978***NOTICE OF INTENTION**

The Governor in Council under section 10 of the *Crown Land (Reserves) Act 1978* gives notice of intention to revoke the following temporary reservations:

**BALLARAT**—The temporary reservation by Order in Council of 10 February 1976 of 991 square metres of land being Crown Allotment 14A, Section 10, Parish of Ballarat as a site for Public Purposes (Departmental Residence)—(Rs. 10124).

**BALLARAT NORTH**—The temporary reservation by Order in Council of 18 December 1903 of 8 hectares of land in the Township of Ballarat North as a site for a Night Soil Depot—(Rs. 5459).

**HADDON**—The temporary reservation by Order in Council of 11 December 1917 of 2.78

hectares of land in the Township of Haddon, Parish of Haddon as a site for the Supply of Gravel—(Rs. 12704).

Dated 21 July 1987

Responsible Minister:

JOANE E. KIRNER

Minister for Conservation, Forests and Lands

L. A. FISHER

Acting Clerk of the Executive Council

*Crown Land (Reserves) Act 1978*  
CROWN LANDS TEMPORARILY RESERVED

The Governor in Council under sections 4 and 7 of the *Crown Land (Reserves) Act 1978* temporarily reserves for the purposes mentioned and also excepts from prospecting or from occupation for mining purposes under any miners right the following Crown lands:

MUNICIPAL DISTRICT OF THE SHIRE OF DUNDAS

BEEAR—Conservation of an area of natural interest, 20.25 hectares being Crown allotment 34, Parish of Bear, as indicated by hatching on plan hereunder. (Rs. 13500).

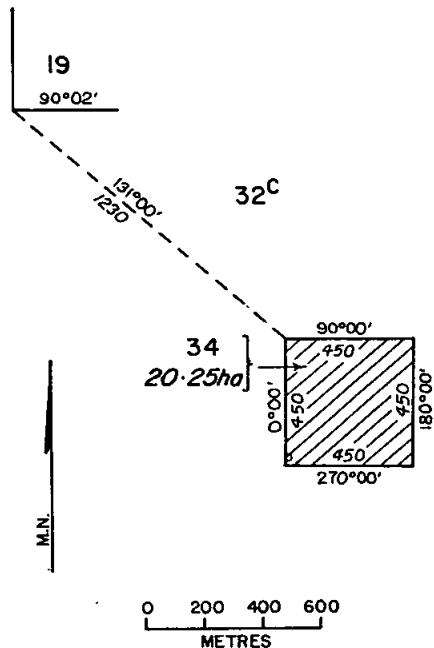

MUNICIPAL DISTRICT OF THE SHIRE OF COHUNA

COHUNA—State School, 1000 square metres, more or less, being Crown allotment 3, Section 4A, Township of Cohuna, Parish of Cohuna, as indicated by hatching on plan hereunder. (Rs. 5164).

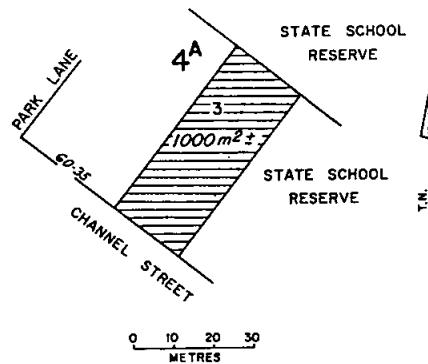

MUNICIPAL DISTRICT OF THE SHIRE OF KARKAROOC

GAALANUNGAH—Water Supply, 3.2 hectares, more or less being Crown Allotment 23B, Parish of Gaalanungah, as indicated by hatching on plan hereunder. (Rs. 13169).

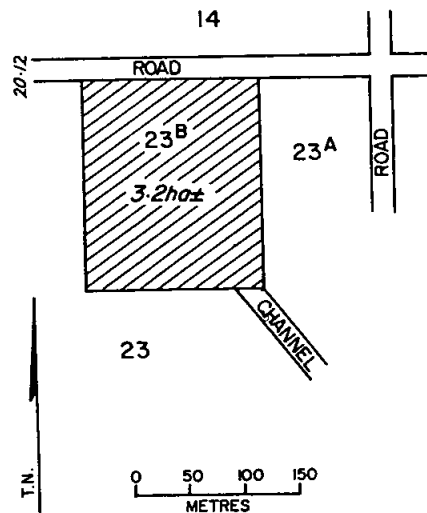

**MUNICIPAL DISTRICT OF THE SHIRE OF BIRCHIP**

**KARYRIE**—Conservation of an area of natural interest, 26.28 hectares being Crown Allotment 103A, Parish of Karyrie as shown on Certified Plan No. 108448 lodged in the Central Plan Office. (Rs. 13275).

**MUNICIPAL DISTRICT OF THE CITY OF WAVERLEY**

**MULGRAVE**—Department of Community Services, 1404 square metres being Crown Allotment 88B, Parish of Mulgrave as shown on Certified Plan No. 108231 lodged in the Central Plan Office. (Rs. 9220).

**MUNICIPAL DISTRICT OF THE SHIRE OF DUNMUNKLE**

**MURTOA**—Public Purposes, 232 square metres, more or less, being Crown Allotment 12, Section 11, Township of Murtoa, Parish of Ashens as shown on Certified Plan No. 108062 lodged in the Central Plan Office. (Rs. 7784).

Dated 21 July 1987

Responsible Minister:

**JOAN E KIRNER**

Minister for Conservation, Forests and Lands

**L. A. FISHER**

Acting Clerk of the Executive Council

**AMBULANCE SERVICES ACT 1986**

The Governor in Council under section 23 of the *Ambulance Services Act 1986* does by this Order transfer to Wimmera District Ambulance Service the asset of Glenelg District Ambulance Service being all that land described in Certificate of Title Volume 6361, Folio 1272075, together with all buildings and improvements thereon.

Dated 21 July 1987

Responsible Minister:

**D. R. WHITE**

Minister for Health

**L. A. FISHER**

Acting Clerk of the Executive Council

*Forests Act 1958*

**GUNYAH RAIN FOREST RESERVE**

The Governor in Council under section 50 (1) of the *Forests Act 1958* sets aside and declares the area of Reserved Forest described in the Schedule hereunder to be a Flora Reserve known as "Gunyah Rain Forest Reserve".

**Schedule**

The Reserved Forest in the Parishes of Gunyah Gunyah and Wonyip containing 550 hectares,

more or less, as shown by shading on the plan hereunder.

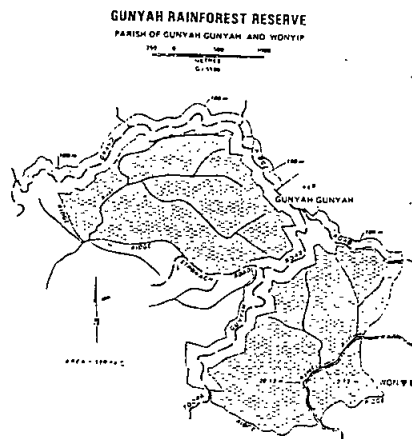

Dated 21 July 1987

Responsible Minister:

**JOAN E. KIRNER**

Minister for Conservation, Forests and Lands

**L. A. FISHER**

Acting Clerk of the Executive Council

*Urban Land Authority Act 1979*

**TRANSFER OF LAND**

**Keilor East**

The Governor in Council under section 19 (1) of the *Urban Land Authority Act 1979* transfers to the Urban Land Authority the land described in the Schedule.

**Schedule**

**Parish of Doutta Galla**

**County of Bourke**

1. Lots 3 to 7 (both inclusive) on Plan of Subdivision No. 138726 and being the whole of the land in Certificates of Title Volume 9487, Folios 007 to 011 respectively;
2. Easements of Way Drainage and Sewerage on Plan of Subdivision No. 142147 and being the whole of the land in Certificate of Title Volume 9547, Folio 565;
3. Easements of Way Drainage and Sewerage on Plan of Subdivision No. 142146 and being the whole of the land in Certificate of Title Volume 9547, Folio 524; and



4. Reserve for Resort and Recreation on Plan of Subdivision No. 142146 and being the whole of the land in Certificate of Title Volume 9547, Folio 523.

Dated 21 July 1987

Responsible Minister:

FRANK NOEL WILKES  
Minister for Housing

L. A. FISHER  
Acting Clerk of the Executive Council

*Crown Land (Reserves) Act 1978*  
**CROWN LAND PERMANENTLY RESERVED**

The Governor in Council under sections 4 and 7 of the *Crown Land (Reserves) Act 1978* permanently reserves for the purpose mentioned and also excepts from prospecting or from occupation for mining purposes under any miners right the following Crown land:

**MUNICIPAL DISTRICT OF THE SHIRE OF STAWELL**

WARRANOOK—Public Purposes, 23 hectares, more or less being Crown Allotment 133C, Parish of Warranook as indicated by hatching on plan hereunder. (Rs. 13370).

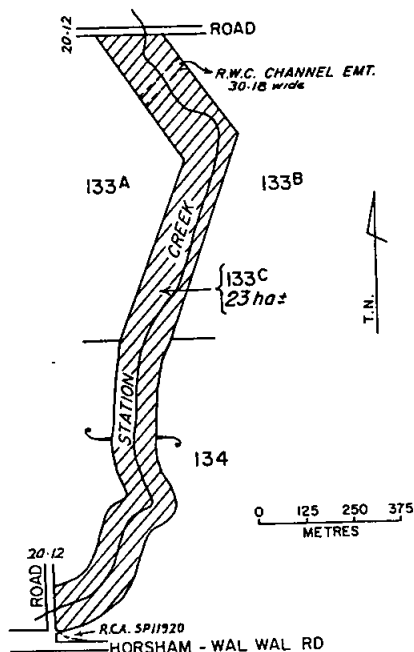

Dated 21 July 1987

Responsible Minister:

JOANE E. KIRNER  
Minister For Conservation, Forests and Lands

L. A. FISHER  
Acting Clerk of the Executive Council

*Local Government Act 1958*

**CONFIRMATION OF SEPARATE RATE SHIRE OF BROADFORD**

The Governor in Council acting under section 287 of the *Local Government Act 1958* confirms a separate rate made by the Council of the Shire of Broadford on 28 May 1987 for the purpose of providing electricity reticulation in the Parishes of Clonbinane and Glenburnie.

Dated 21 July 1987

Responsible Minister:

J. L. SIMMONDS  
Minister for Local Government

L. A. FISHER  
Acting Clerk of the Executive Council

**LOCAL GOVERNMENT DEPARTMENT**

Notice of Approval of Agreement

Mallee Valuation Group

The Governor in Council acting under section 254 (10) of the *Local Government Act 1958* approves the agreement between the Councils of the Cities of Mildura and Swan Hill, the Shires of Swan Hill, Wycheproof, Walpeup, Birchip and Karkaroc to form a Valuation Group to be known as the Mallee Valuation Group.

Dated 21 July 1987

Responsible Minister:

J. L. SIMMONDS  
Minister for Local Government

L. A. FISHER  
Acting Clerk of the Executive Council

**PARLIAMENTARY COMMITTEES ACT 1968**

The Governor in Council, pursuant to section 4F (1) (a) (ii) of the *Parliamentary Committees Act 1968*, refers to the Joint Investigatory Economic and Budget Review Committee for inquiry consideration and report to Parliament by 31 December 1987 the matter of whether the imposition of limits on the borrowings of commercial trading authorities covered by the Borrowing and Investment Powers Act, viz the State Electricity Commission, the Gas and Fuel Corporation and the Melbourne and Metropolitan Board of Works is appropriate and

desirable, and if deemed so, what would be the appropriate mechanism for the establishment and review of these limits, in particular whether this be by—

- (i) amendment to the relevant Act or,
- (ii) adjustment by regulation (subject to disallowance if both Houses agree).

Dated 21 July 1987

Responsible Minister:

R. A. JOLLY  
Treasurer

L. A. FISHER  
Acting Clerk of the Executive Council

*Urban Land Authority Act 1979*  
TRANSFER OF LAND  
Churchill

The Governor in Council under section 19 (1) of the *Urban Land Authority Act 1979* transfers to the Urban Land Authority the land described in the Schedule.

Schedule  
Parish of Hazelwood  
County of Buln Buln

1. Part of Lot 3 on Plan of Submission No. 139395 being the balance of Land remaining untransferred in Certificate of Title Volume 9651 Folio 237.

2. Part of Crown Allotments 24 and 26 section A being the whole of the land in Certificate of Title Volume 9485 Folio 465.

3. Lot 34 on Plan of Subdivision No. 72657 being the whole of the land in Certificate of Title Volume 8622 Folio 200.

4. Part of Crown Allotments 29, 30, 30A, 35 and 36 section A and being the land remaining untransferred in Certificate of Title Volume 8596 Folio 612.

5. Lot A on Plan of Subdivision No. 200728X and being the whole of the land in Certificate of Title Volume 9637 Folio 107.

6. Lot D on Plan of Subdivision No. 139396 and being the whole of the land in Certificate of Title Volume 9485 Folio 463.

Dated 21 July 1987

Responsible Minister:

FRANK NOEL WILKES  
Minister for Housing

L. A. FISHER  
Acting Clerk of the Executive Council

*Local Government Act 1958*

DIRECTION FOR CORRECTIONS TO BE  
MADE TO THE 1986-87 VOTER'S ROLL—  
CITY OF SALE

The Governor in Council, acting under section 90 of the *Local Government Act 1958* directs that the corrections contained in Schedule A be made to the voters roll for the South and North Wards of the City of Sale.

List of Names to be excluded from Voter's Roll for South Ward and included in the Voter's Roll for North Ward

<i>Name</i>	<i>Address</i>
Aitken, Pauline Ann	108 Pearson Street, Sale.
Barry, Angela Rose	141 Pearson Street, Sale.
Barry, Anthony James	141 Pearson Street, Sale.
Barry, Christopher Joseph	141 Pearson Street, Sale.
Barry, David Andrew	141 Pearson Street, Sale.
Barry, John William	141 Pearson Street, Sale.
Bedggood, Jack	81 Pearson Street, Sale.
Bedggood, Kevin	81 Pearson Street, Sale.
Bedggood, Marjorie Florence	81 Pearson Street, Sale.
Blank, Barbara	158 Pearson Street, Sale.
Brander, Jayne Elizabeth	133 Pearson Street, Sale.
Brice, Ada Veronica	75 Pearson Street, Sale.
Cain, Wendy Francis	135 Pearson Street, Sale.
Camin, Anna Paulina	123 Pearson Street, Sale.
Camin, Clarence Leonard	123 Pearson Street, Sale.
Carter, Ian Leslie	117 Pearson Street, Sale.
Cobain, Alan Johnson	149 Pearson Street, Sale.
Cobain, Mona Beatrice	149 Pearson Street, Sale.
Crawford, Diane Elizabeth	137 Pearson Street, Sale.
Crawford, Kenneth	137 Pearson Street, Sale.
Driscoll, Bernard Francis	172 Pearson Street, Sale.

Edgley, Helene Frances	150 Pearson Street, Sale.	Magnuson, Margaret Victoria	127 Pearson Street, Sale.
Edgley, Ian	150 Pearson Street, Sale.	Maiden, Alfred Edward	154 Pearson Street, Sale.
Emphield, Lynette Mary	106 Pearson Street, Sale.	Maiden, Mary Elizabeth	154 Pearson Street, Sale.
Emphield, Neil James	106 Pearson Street, Sale.	Mewha, Kathleen Imelda	129 Pearson Street, Sale.
Gallagher, Muriel Joan	99 Pearson Street, Sale.	Mewha, Malcolm	129 Pearson Street, Sale.
Gallagher, Norman Patrick	99 Pearson Street, Sale.	Mewha, Mark Francis	129 Pearson Street, Sale.
Graham, Veronica Nancy	153 Pearson Street, Sale.	Milanovic, Peter Alexander	108 Pearson Street, Sale.
Hammill, Leslie Warren	2/165 Pearson Street, Sale.	Millar, Nita Verelle	174 Pearson Street, Sale.
Hannaford, Joan Daphne	166 Pearson Street, Sale.	Millham, Andrew Mark	5/165 Pearson Street, Sale.
Hannaford, John Francis	166 Pearson Street, Sale.	Newman, Rosemary June	156 Pearson Street, Sale.
Harrap, Geoffrey Rylott	135 Pearson Street, Sale.	Olsson, Frederick John	144 Pearson Street, Sale.
Hart, James	113 Pearson Street, Sale.	O'Shea, Evelyn Mavis	91 Pearson Street, Sale.
Hart, Valerie May	113 Pearson Street, Sale.	O'Shea, Lynette Ann	91 Pearson Street, Sale.
Horstman, Kenneth John	155 Pearson Street, Sale.	Parsons, Lorraine Eileen	89 Pearson Street, Sale.
Horstman, Linda Margaret	155 Pearson Street, Sale.	Potter, Anna Margit	69 Pearson Street, Sale.
Hua, Quyen Nghiep	79 Pearson Street, Sale.	Potter, Frank Henry	69 Pearson Street, Sale.
Hua, Tan Van	79 Pearson Street, Sale.	Ray, Julie-Anne	109 Pearson Street, Sale.
Janczukowicz, Olga	152 Pearson Street, Sale.	Rose, Judith Ann	145 Pearson Street, Sale.
Jones, Karen Louise	105 Pearson Street, Sale.	Rose, Kevin Charles	145 Pearson Street, Sale.
Jones, Kevin Samuel	105 Pearson Street, Sale.	Ruff, Atholle Margaret	160 Pearson Street, Sale.
Jones, Maureen Alm	105 Pearson Street, Sale.	Ruff, Oswald Abraham	160 Pearson Street, Sale.
Jones, Susan Maureen	105 Pearson Street, Sale.	Ruff, Victor Claude	77 Pearson Street, Sale.
Kelberg, Cyril James	147 Pearson Street, Sale.	Seears, Keith Bailey	98 Pearson Street, Sale.
Kerr, Francine Bernadette	110 Pearson Street, Sale.	Seears, Sylvia	98 Pearson Street, Sale.
Kerr, Michael James	110 Pearson Street, Sale.	Slater, Shirley Anne	139 Pearson Street, Sale.
Lewis, John	121 Pearson Street, Sale.	Slater, Stephen Arthur	139 Pearson Street, Sale.
Lewis, Katherine Louisa	121 Pearson Street, Sale.	Stipic, Hanna Erika	164 Pearson Street, Sale.
McGrath, Pamela Faye	1/165 Pearson Street, Sale.	Stipic, Stefan	164 Pearson Street, Sale.
		Templeton, James Ronald	143 Pearson Street, Sale.
		Templeton, Joan Patricia	143 Pearson Street, Sale.

Tomczyk, Boleslaw	95 Pearson Street, Sale.	Augousti, Antigoni, 5 Cynthia Street, Morwell 3840.
Tomczyk, Maria	95 Pearson Street, Sale.	Augousti, Demosthenis, 5 Cynthia Street, Morwell 3840.
Vella, Charles	159 Pearson Street, Sale.	Baird, Allan James, 96 Crinigan Road, Morwell 3840.
Vella, David Richard	159 Pearson Street, Sale.	Baird, Nancy Judith, 96 Crinigan Road, Morwell 3840.
Vella, Johanna	159 Pearson Street, Sale.	Britton, Johanna Maria, 14 Butters Street, Morwell 3840.
Wallace, Mary	77 Pearson Street, Sale.	Britton, Wayne, 14 Butters Street, Morwell 3840.
Winifred		Brown, Mavis Dolly, 6 Butters Street, Morwell 3840.
Warneke, Irene Ellen	157 Pearson Street, Sale.	Brown, William Thomas, 6 Butters Street, Morwell 3840.
Warneke, Robin Edward	157 Pearson Street, Sale.	Easton, William John, 22 Monash Street, Morwell 3840.
Warry, Janet Shirley	161 Pearson Street, Sale.	Love, Marlene Elbertha, 17 Cynthia Street, Morwell 3840.
Warry, Michael John	161 Pearson Street, Sale.	McKenzie, Barry John, 17 Butters Street, Morwell 3840.
Yeates, Joanne Maree	6/165 Pearson Street, Sale.	McKenzie, Lorna Marion, 22 Spring Court, Morwell 3840.

Dated 28 July 1987

Responsible Minister:

J. L. SIMMONDS

Minister for Local Government

L. A. FISHER

Acting Clerk of the Executive Council

*Local Government Act 1958*

**DIRECTION FOR CORRECTIONS TO BE MADE TO THE 1986-87 VOTERS' ROLL—SHIRE OF MORWELL**

The Governor in Council, acting under section 90 of the *Local Government Act 1958* directs that the corrections contained in Schedule A be made to the voters roll for the North, West and South Ridings of the Shire of Morwell.

Schedule A

Names to be Deleted from West Riding Roll and Added to North Riding Roll

Alway, Gerald, 20 Butters Street, Morwell 3840.

Alway, Linda Debra Louise, 20 Butters Street, Morwell 3840.

Alway, Maureen Margaret, 20 Butters Street, Morwell 3840.

Ambler, Edna May, 15 Cynthia Street, Morwell 3840.

Ambler, Ronald Edward, 15 Cynthia Street, Morwell 3840.

Angelo, Denise Monica, 3 Cynthia Street, Morwell 3840.

Angelo, Noel Lionel, 3 Cynthia Street, Morwell 3840.

McKenzie, Susan Jean, 17 Butters Street, Morwell 3840.

McKenzie, Tammie-Jayne, 22 Spring Court, Morwell 3840.

Moncrieff, Adrian Thomas, 12 Butters Street, Morwell 3840.

Moncrieff, Carol Ann, 12 Butters Street, Morwell 3840.

Moncrieff, Gwendolyn Niree, 12 Butters Street, Morwell 3840.

Moncrieff, Hector, 12 Butters Street, Morwell 3840.

Paulet, Patricia Margaret, 3 Butters Street, Morwell 3840.

Paulet, Shane William, 3 Butters Street, Morwell 3840.

Peter, Carmel Agnes, 44 Spring Court, Morwell 3840.

Peter, Kenneth James, 44 Spring Court, Morwell 3840.

Petrides, Maria, 31 Waratah Drive, Morwell 3840.

Petrides, Stylianos, 31 Waratah Drive, Morwell 3840.

Randall, Lorraine Faye, 37 Spring Court, Morwell 3840.

Randall, Rodney Wayne, 37 Spring Court, Morwell 3840.

Salvatore, Connie Maria, 41 Spring Court, Morwell 3840.

Salvatore, Maria Conchetta, 41 Spring Court, Morwell 3840.

Smith, Dianne Elizabeth, 15 Butters Street, Morwell 3840.

Smith, Ross James, 15 Butters Street, Morwell 3840.

Szczepanek, Sofia Theresa, 14 Spring Court, Morwell 3840.

Zandona, Cheryl Ann, 4 Monash Street, Morwell 3840.

Names to be Deleted from North Riding Roll and Added to West Riding Roll

Badger, Ruby, 116 Maryvale Road, Morwell 3840.

Bartlett, Melissa Jane, 111 Vary Street, Morwell 3840.

Bartlett, Samuel Ian, 111 Vary Street, Morwell 3840.

Brindley, Dennis Raymond, 95 Vary Street, Morwell 3840.

Brindley, Gloria, 95 Vary Street, Morwell 3840.

Danaher, Stephen Greg, 55 Savige Street, Morwell 3840.

Day, Barry Paul, 93 Vary Street, Morwell 3840.

Ellwood, Scott Lawrence, 97 Vary Street, Morwell 3840.

Grima, Marianne Toni, 49 Savige Street, Morwell 3840.

Grima, Mary Ann, 49 Savige Street, Morwell 3840.

Hillsley, Robert Guye, 87 Vary Street, Morwell 3840.

Hillsley, Sheryl Marjorie, 87 Vary Street, Morwell 3840.

Shanahan, Michael Thomas, 19 Hourigan Road, Morwell 3840.

Waddington, Lawrence Russell, 5 Hourigan Road, Morwell 3840.

Waddington, Vira Joy, 5 Hourigan Road, Morwell 3840.

White, Wendy Joy, 4 Albert Court, Morwell 3840.

Williams, Anthony, 19 Hourigan Road, Morwell 3840.

Williams, Helen, 19 Hourigan Road, Morwell 3840.

Woszczeiko, John, 7 Albert Court, Morwell 3840.

Woszczeiko, Maureen Elizabeth, 7 Albert Court, Morwell 3840.

Young, Ross Goften, 101 Vincent Road, Morwell 3840.

Young, Ross Goften, 101 Vincent Road, Morwell 3840.

Zerafa, Anita, 6 Joseph Court, Morwell 3840.

Zerafa, Frank, 6 Joseph Court, Morwell 3840.

Names to be Deleted from South Riding Roll and Added to West Riding Roll

Ashton, Anne Theresa, Lot 2 Hegla Drive, Yallourn North 3838.

Ashton, Douglas James, Lot 2 Hegla Drive, Yallourn North 3838.

Bawden, Ann Marie, 59 Holmes Road, Morwell 3840.

Bawden, Kathleen Lorelle, 59 Holmes Road, Morwell 3840.

Beames, Glenice Irene, 47 Holmes Road, Morwell 3840.

Beames, Paul William, 47 Holmes Road, Morwell 3840.

Borgwardt, Frank, 67 Holmes Road, Morwell 3840.

Borgwardt, Marianne, 67 Holmes Road, Morwell 3840.

Borgwardt, Gunther, 67 Holmes Road, Morwell 3840.

Cardillo, Tina, 125 Holmes Road, Morwell 3840.

Cloak, Ronald William, 66 Holmes Road, Morwell 3840.

Cole, Elaine Alice, 58 Holmes Road, Morwell 3840.

Cole, George Ambrose, 58 Holmes Road, Morwell 3840.

Cole, Ronald Preston, 58 Holmes Road, Morwell 3840.

Dickson, Marjorie Lillian, 10 Harold Street, Morwell 3840.

Dickson, William Peter, 10 Harold Street, Morwell 3840.

Pym, Derek Rodney, 1/8 Harold Street, Morwell 3840.

Sao, Chamda, 59 Holmes Road, Morwell 3840.

Sao, Sokhan, 59 Holmes Road, Morwell 3840.

Names to be Deleted from West Riding Roll and Added to South Riding Roll

Bull, David, 55 Comans Street, Morwell (Varys Track).

Rosato, Antonio, Coalville Road, Moe (Varys Track).

Rosato, Michael, Coalville Road, Moe (Blacks Track).

Schack, Rolf Heinz, Arwon Drive, Hernes Oak 3825.

Schack, Susan Gail, Arwon Drive, Hernes Oak 3825.

Schessl, Franz Otto, 41 Arwon Drive, Hernes Oak 3825.

2020 G 29 29 July 1987

Victoria Government Gazette

Schessl, Margaret Mary, 41 Arwon Drive,  
Hernes Oak 3825.

Dated 28 July 1987

Responsible Minister:

J. L. SIMMONDS

Minister for Local Government

L. A. FISHER

Acting Clerk of the Executive Council

*Local Government Act 1958*

**DIRECTION FOR CORRECTIONS TO BE  
MADE TO THE 1986-87 VOTERS' ROLL—  
CITY OF KEILOR**

The Governor in Council, acting under section 90 of the *Local Government Act 1958* directs that the following corrections be made to the voters roll for the City of Keilor to be held on 1 August 1987:

- List of Names to be included on the Voters' Roll for the Niddrie Ward of the City of Keilor

<i>Name</i>	<i>Address</i>
Ortisi, Salvatore	10 Monte Carlo Drive, Avondale Heights 3034

Dated 28 July 1987

Responsible Minister:

J. L. SIMMONDS

Minister for Local Government

L. A. FISHER

Acting Clerk of the Executive Council

*Local Government Act 1958*

**DIRECTION FOR CORRECTIONS TO BE  
MADE TO THE 1986-87 VOTERS' ROLL—  
CITY OF BENALLA**

The Governor in Council, acting under section 90 of the *Local Government Act 1958* directs that the following corrections be made to the voters roll for the City of Benalla:

- List of Names to be included on the Voters' Roll for the City of Benalla

<i>Name</i>	<i>Address</i>
Hanrahan, Margaret Rose	3/36 Bridge Street West, Benalla 3672

Dated 28 July 1987

Responsible Minister:

J. L. SIMMONDS

Minister for Local Government

L. A. FISHER

Acting Clerk of the Executive Council

*Local Government Act 1958*

**DIRECTION FOR CORRECTIONS TO BE  
MADE TO THE 1986-87 VOTERS' ROLL—  
CITY OF COLLINGWOOD**

The Governor in Council, acting under section 90 of the *Local Government Act 1958* directs that the following corrections contained in Schedules A, B and C and lodged at the office of the Director-General for Local Government at 480 Collins Street, Melbourne and at the office of the City of Collingwood, Hoddle Street, Abbotsford be made to the voters' rolls for the Abbotsford, Barkly and Clifton Hill Wards of the City of Collingwood.

Dated 28 July 1987

Responsible Minister:

J. L. SIMMONDS

Minister for Local Government

L. A. FISHER

Acting Clerk of the Executive Council

*Local Government Act 1958*

**SHIRE OF KORUMBURRA**

Direction for Corrections to be made to the  
1987/88 Voters' Roll

The Governor in Council, acting under section 90 of the *Local Government Act 1958*, directs that the corrections contained in Schedule A be made to the Voters' Rolls for the South and Central Ridings of the Shire of Korumburra.

**Schedule A**

List of Names of Voters to be added to the Municipal Roll in the Shire of Korumburra for the following ridings:

**Central Riding:**

5a: ANDRONICO, Annunziata; Rudds Road, Korumburra. (Non-naturalised resident voter.)

36a: BRUZZESE, Annunziata; 59 Mine Road, Korumburra. (Non-naturalised resident voter.)

36b: BRUZZESE, Michele; 59 Mine Road, Korumburra. (Non-naturalised resident voter.)

157a: NOBILE, Carmeto; 19 Guys Road, Korumburra. (Non-naturalised resident voter.)

157b: NOBILE, Natalina; 12 Princes Street, Korumburra. (Non-naturalised resident voter.)

157c: NOBILE, Vincenza; 19 Guys Road, Korumburra. (Non-naturalised resident voter.)

179a: REALE, Concetta; 21 Guys Road, Korumburra. (Non-naturalised resident voter.)

179b: REALE, Franco; 21 Guys Road, Korumburra. (Non-naturalised resident voter.)

**South Riding:**

58a: FAVA, Rosa; Jumbunna Road, Korumburra. (18 year old resident voter.)

76a: GRENON, Jean-Paul; La Fernon Charolais Stud, Jeetho. (Non-naturalised resident voter.)

176a: MORRIS, Joan Elizabeth; P.O. Box 243, Korumburra. (Non-resident voter omitted in error.)

191a: PATTEN, Henry Robert; RMB 3505, Warragul Road, Korumburra. (Non-resident voter omitted in error.)

286a: WOOLLEY, David James; 12 Bourke Street, Korumburra. (Non-resident voter omitted in error.)

290a: WYATT, Lester Charles; Fairbank Road, Arawata. (Non-resident voter omitted in error.)

Dated 28 July 1987

Responsible Minister:

J. L. SIMMONDS  
Minister for Local Government

L. A. FISHER  
Acting Clerk of the Executive Council

*Local Government Act 1958*

CITY OF COLLINGWOOD

Direction for Corrections to be made to the 1986-87 Voters' Roll

The Governor in Council, acting under section 90 of the *Local Government Act 1958*, directs that the corrections contained in Schedule A and lodged at the office of the Director-General for Local Government, 480 Collins Street, Melbourne and at the office of the City of Collingwood, Hoddle Street, Abbotsford be made to the voters' rolls for the Clifton Hill Ward of the City of Collingwood.

Schedule A

Deletions to Clifton Hill Ward—Booth Rolls

Roll No.	Name
121	Arrowsmith, Alfreda P.
149	Baker, Alfred Charles
180	Barr, Archibald T.
187	Bate, Patricia J.
657	Cottingham, Edith F.
682	Coyne, Margaret
1107	Galli, William
1294	Hall, Ian G.
1541	Innes-Irons, Judith Ann
1544	Ioannidis, Nikolaos
1580	Jane, Simon A.
1884	Lithgow, Jacinta M.
2040	Marett, Helena
2360	Muhleisen, Peter J.
2767	Redford, Alfred W.

2768 Redford, Roger Stephen

3031 Simpson, Dennis James

3144 Stavrakis, Sokratis

3166 Stevens, Kathleen M.

3171 Stewart, Colleen Ann

3219 Symonds, Patricia Anne

I hereby certify that the abovementioned voters are included in error on the Clifton Hill Ward Rolls.

Dated 28 July 1987

Responsible Minister:

J. L. SIMMONDS  
Minister for Local Government

L. A. FISHER

Acting Clerk of the executive Council

*Local Government Act 1958*

CITY OF PRESTON

Direction for Corrections to be made to the 1986-87 Voters' Roll

The Governor in Council, acting under section 90 of the *Local Government Act 1958*, directs that the corrections contained in Schedule A and lodged at the office of the Director-General for Local Government, 480 Collins Street, Melbourne and at the office of the City of Preston, High Street, Preston be made to the voters' rolls for the South East and North East Wards of the City of Preston.

Dated 28 July 1987

Responsible Minister:

J. L. SIMMONDS  
Minister for Local Government

L. A. FISHER

Acting Clerk of the Executive Council

*Water and Sewerage Authorities (Restructuring) Act 1983*

*Sewerage Districts Act 1958*

EMERALD DISTRICT WATER BOARD

Site of Sewage Treatment Works Approved

The Administrator in Council, under the provisions of the *Water and Sewerage Authorities (Restructuring) Act 1983* and the *Sewerage Districts Act 1958* approves of the site for sewage treatment works as shown in brown on the accompanying plan—(Corr. No. P87/40/D).

Dated 14 July 1987

Responsible Minister:

ANDREW McCUTCHEON  
Minister for Water Resources

L. A. FISHER

Acting Clerk of the Executive Council

*Water and Sewerage Authorities (Restructuring)  
Act 1983**Water Act 1958***EMERALD DISTRICT WATER BOARD****Sites of Pump Station and Pipelines Approved**

The Administrator in Council, under the provisions of the *Water and Sewerage Authorities (Restructuring) Act 1983* and the *Water Act 1958* approves of the sites of a pump station and pipelines as shown in yellow and red on the accompanying plan—(Corr. No. L86/395/2).

Dated 14 July 1987

Responsible Minister:

**ANDREW McCUTCHEON**  
Minister for Water Resources

**L. A. FISHER**  
Acting Clerk of the Executive Council

*Latrobe Valley Act 1958***OFFICE OF THE MINISTER FOR WATER  
RESOURCES****Appointment of Members of the Latrobe Valley  
Water and Sewerage Board**

The Administrator in Council under the powers conferred by the *Latrobe Valley Act 1958*, hereby appoints Richard Allen James Stanistreet as the Member representing industry located in the Latrobe Valley on the Latrobe Valley Water and Sewerage Board for a period of one year from 14 July 1987.

Dated 14 July 1987

Responsible Minister:

**ANDREW McCUTCHEON**  
Minister for Water Resources

**L. A. FISHER**  
Acting Clerk of the Executive Council

*Latrobe Valley Act 1958***OFFICE OF THE MINISTER FOR WATER  
RESOURCES****Appointment of Members of the Latrobe Valley  
Water and Sewerage Board**

The Administrator in Council under the powers conferred by the *Latrobe Valley Act 1958*, hereby appoints Maxwell Henry Williamson, an officer of the State Electricity Commission of Victoria, as a Member of the Latrobe Valley Water and Sewerage Board for a period of one year from 14 July 1987.

Dated 14 July 1987

Responsible Minister:

**ANDREW McCUTCHEON**  
Minister for Water Resources

**L. A. FISHER**  
Acting Clerk of the Executive Council

*Building Societies Act 1986***APPOINTMENT OF MEMBERS OF THE  
VICTORIAN BUILDING SOCIETIES  
COUNCIL**

The Administrator in Council under section 13 of the *Building Societies Act 1986*—

- (i) appoints for the period from the date of this Order to 30 June 1988, Robert William McIntyre Farrow and;
- (ii) re-appoints for the period from the date of this Order to 30 June 1988, Edward Brian Thomas (Chairperson), Christopher John Stewart, Brian Geoffrey Thom, Jane Margaret Harvey, Allen Lesley Moore, Anthony Vincent Cahir and the person for the time being appointed or acting in the position of Registrar of Building Societies;

under the *Building Societies Act 1986* as members of the Victorian Building Societies Council established by that Act.

Dated 30 June 1987

Responsible Minister:

**R. A. JOLLY**  
Treasurer

**L. A. FISHER**  
Acting Clerk of the Executive Council

*Water and Sewerage Authorities (Restructuring)  
Act 1983***BRIGHT DISTRICT WATER BOARD****Amendment to Constitution**

The Governor in Council, under the provisions of the *Water and Sewerage Authorities (Restructuring) Act 1983*, approves of the following amendment to the constitution of the Bright District Water Board.

The following clause of the constituting Order shall be abolished:

“H. The Board shall comprise six members of whom three shall be elected by the Councillors of the Shire of Bright and three shall be appointed by the Minister of Water Supply.”

Instead the following clause shall be inserted:

“H. The members of the said Board shall be the Councillors of the Bright Riding and three other persons appointed by the Minister for Water Resources”—(Corr. No. 84/2019/7).

Dated 2 June 1987

Responsible Minister:

**ANDREW McCUTCHEON**  
Minister for Water Resources

**E. M. MILLER**  
Acting Clerk of the Executive Council



*Local Government Act 1958*

## DIRECTION FOR CORRECTIONS TO BE MADE TO THE 1986-87 VOTERS' ROLL—CITY OF HAWTHORN

The Governor in Council, acting under section 90 of the *Local Government Act 1958* directs that the following corrections be made to the voters roll for the City of Hawthorn:

<i>Wards</i>	<i>Name</i>	<i>Address</i>
Additions		
Auburn	Cowaghan, Angela Patricia	44 Auburn Parade, Hawthorn East
Auburn	Harley, Jacqueline Elizabeth	10/247 Riversdale Road, Hawthorn East
Glenferrie	Brodzinski, Mary	4/147 Victoria Road, Hawthorn East
Glenferrie	Hargrave, Alan Wayne	4/24 Elphin Grove, Hawthorn
Glenferrie	McDonald, Joan Mary	172 Rathmines Road, Hawthorn East
Glenferrie	Money, Kathryn	9/799 Burwood Road, Hawthorn
Glenferrie	Murphy, Elizabeth Ann	2 Lorne Road, Hawthorn East
Glenferrie	Schellekews, Mary-Anne Petranella	4/5 Stanley Avenue, Hawthorn East
Power	Hawkins, Dimity Jane	206 Auburn Road, Hawthorn
Power	Muller, Nancy Olive	7 Hambledon Road, Hawthorn
Power	Perrett, Matthew Neal	8/20 Fordholm Road, Hawthorn
Yarra	Croxford, John Walter	8A Myrtle Street, Hawthorn
Yarra	Freemantle, Cecily Jane	33 Chrystobel Crescent, Hawthorn
Deletions		
Auburn	Atkins, Colin James	13/203 Auburn Road, Hawthorn
Auburn	Cordina, Suzan Francesca	6/716 Burwood Road, Hawthorn East
Auburn	Frank, Helen Therese	7/4 Brookfield Court, Hawthorn East
Auburn	Holland, Mary Ann	29 Sinclair Avenue, Glen Iris
Auburn	McGarry, Carole-Ann	9/11 Auburn Grove, Hawthorn East
Auburn	McLean, Suzanne Dunster	2/867 Toorak Road, Hawthorn East
Auburn	Teh, Katherine Yoke Cheng	217 Auburn Road, Hawthorn
Glenferrie	Clarke, Jonathan Ernest Murray	5 Temple Street, Hawthorn East
Glenferrie	El-Khoury, Hassib	92 Auburn Road, Hawthorn
Glenferrie	El-Khoury, Sonia	92 Auburn Road, Hawthorn
Glenferrie	Sharp, Ailana Merryn	15 Sercombe Grove, Hawthorn
Glenferrie	Wilson, Peter John	65 Harcourt Street, Hawthorn East
Power	Cole, Judith	15/181 Power Street, Hawthorn
Power	Duthie, Mary Elizabeth	3/506 Glenferrie Road, Hawthorn
Power	Harley, Jacqueline Elizabeth	4/566 Glenferrie Road, Hawthorn
Power	Hicks, Rachel Christina	33 Wattle Road, Hawthorn
Power	Murphy, Elizabeth Ann	19 Elmie Street, Hawthorn
Power	Wynn, Janine	13/131 Riversdale Road, Hawthorn
Yarra	Barwell, Grace Georgina	25/168 Power Street, Hawthorn
Yarra	Dempster, Amanda Winfield	2/1A Kinkora Road, Hawthorn
Yarra	Henry, Raymond Lester	55 Linda Crescent, Hawthorn
Yarra	Rado, Eva	3/40 Creswick Street, Hawthorn

Dated 28 July 1987

Responsible Minister:

J. L. SIMMONDS

Minister for Local Government

L. A. FISHER

Acting Clerk of the Executive Council

*Local Government Act 1958*

## CITY OF PRESTON

## Direction for corrections to be made to the 1986/87 voters' roll

The Governor in Council, acting under section 90 of the *Local Government Act 1958*, directs that the corrections contained in Schedules A, B and C be made to the voters' rolls for the South East, South West and North Central Wards of the City of Preston.

## SCHEDULE A

List of Names to be added to the Voters' Roll for the South West Ward and added to Voters' Roll for the South East Ward of the City of Preston.

<i>Name</i>	<i>Address</i>
Riley, Phyllis Victoria Margarita	1 Powell Street, Reservoir 3073
Brylce, Eric	3 Powell Street, Reservoir 3073
Rizzi, Angelo	5 Powell Street, Reservoir 3073
Rizzi, Paola	5 Powell Street, Reservoir 3073
D'Achille, Nicola	7 Powell Street, Reservoir 3073
D'Achille, Maria	7 Powell Street, Reservoir 3073
D'Achille Pina	7 Powell Street, Reservoir 3073
Ritchie, Sheila Myra	9 Powell Street, Reservoir 3073
Di Lorenzo, Gino	11 Powell Street, Reservoir 3073
Di Lorenzo, Rosanna	11 Powell Street, Reservoir 3073

## SCHEDULE B

List of Names to be added to the Voters' Roll for the North West Ward and added to the Voters' Roll for the South East Ward of the City of Preston.

<i>Name</i>	<i>Address</i>
Nouachkos, Alex	1 Crawley Street, Reservoir
Williams, Benjamin Arnold	3 Crawley Street, Reservoir
Williams, Norma Marle	3 Crawley Street, Reservoir
Haore, Darryl Leighton	5 Crawley Street, Reservoir
Blasich, Dorina	7 Crawley Street, Reservoir
Blasich, Gioyanni	7 Crawley Street, Reservoir
Christopoulos, Afroditi	9 Crawley Street, Reservoir
Christopoulos, Antonios	9 Crawley Street, Reservoir
Christopoulos, Christos	9 Crawley Street, Reservoir
Williams, Kevin Gordon	11 Crawley Street, Reservoir
Williams, Therese Mary	11 Crawley Street, Reservoir
Christopoulos, Betty	13 Crawley Street, Reservoir
Christopoulos, Fotis	13 Crawley Street, Reservoir
Valls, Erenst John	17 Crawley Street, Reservoir
Valls, John Erenst	17 Crawley Street, Reservoir
Valls, Louise Jane	17 Crawley Street, Reservoir
Valls, Patricia Margaret	17 Crawley Street, Reservoir
Levens, Helen Campbell	19 Crawley Street, Reservoir
Bower, John Alfred	19A Crawley Street, Reservoir
Bower, Lola Gwendolyn	19A Crawley Street, Reservoir
Ambrose, Francis Wesley	2 Crawley Street, Reservoir
Ambrose, Marjorie Edna	2 Crawley Street, Reservoir
Hancock, Iris Isabel	4 Crawley Street, Reservoir

Hancock, Jean Violet	4 Crawley Street, Reservoir
Bramich, Gary Alan	6 Crawley Street, Reservoir
Bramich, Sherrill	6 Crawley Street, Reservoir
Bird, Phyllis Irene	8 Crawley Street, Reservoir
Goldsworthy, Laurence Leo	10 Crawley Street, Reservoir
Goldsworthy, Mavis Olive	10 Crawley Street, Reservoir
Goldsworthy, Rosemary	10 Crawley Street, Reservoir
Iulianetti, Carmine	16 Crawley Street, Reservoir
Iulianetti, Filomena	16 Crawley Street, Reservoir
Zaffino, Raffaele	20 Crawley Street, Reservoir
Fairchild, Harold Robert	22 Crawley Street, Reservoir
Palmieri, Michele	42 Dundee Street, Reservoir, for 24 Crawley Street, Reservoir
Wannouche, Majed	24 Crawley Street, Reservoir
Wannouche, Natida	24 Crawley Street, Reservoir

SCHEDULE C

List of Names to be added to the Voters' Roll for the North West Ward and added to the Voters' Roll for the South East Ward of the City of Preston.

<i>Name</i>	<i>Address</i>
Tetu, Ethel Jean	2 Powell Street, Reservoir
Campbell, John Thomas	4 Powell Street, Reservoir
Papagiorgiou, Christos	6 Powell Street, Reservoir
Papagiorgiou, Evangelia	6 Powell Street, Reservoir
Papagiorgiou, Peter	6 Powell Street, Reservoir
Cvetkoski, Najden	8 Powell Street, Reservoir
O'Brien, Eveline Clarke	10 Powell Street, Reservoir
Andrews, Michelle Lee	12 Powell Street, Reservoir
Quinn, Michael James	12 Powell Street, Reservoir
Podgornik, Peter Paul	16 Powell Street, Reservoir
Podgornik, Alicia Susan	16 Powell Street, Reservoir
Di Lorenzo, Giovanna	14 Powell Street, Reservoir
Di Lorenzo, Iole	14 Powell Street, Reservoir
Stragalinos, George	21 Golhill Avenue, Doncaster for 1/18 Powell Street, Reservoir
Dunlop, Russell	1/18 Powell Street, Reservoir
Yarnold, Daryl Charles	3/18 Powell Street, Reservoir
Yarnold, Doris Josephine	3/18 Powell Street, Reservoir
Jovicic, Kim	4/18 Powell Street, Reservoir
McGowan, Kevin Joseph	20 Powell Street, Reservoir
McGowan, Mary	20 Powell Street, Reservoir
Hayward, Ian James	20A Powell Street, Reservoir
Hayward, Lynette Rhonda	20A Powell Street, Reservoir

Dated 28 July 1987

Responsible Minister:

J. L. SIMMONDS

Minister for Local Government

L. A. FISHER  
Acting Clerk of the Executive Council

*Local Government Act 1958*  
CITY OF SPRINGVALE

Direction for Corrections to be made to the 1986-87 Voters' Roll

The Governor in Council, acting under section 90 of the *Local Government Act 1958*, directs that the following corrections contained in Schedule A be made to the voters' rolls for the South and Central Wards of the City of Springvale.

SCHEDULE A

List of Names to be added to the Voters' Roll for the Central Ward and deleted from the Voters' Roll for the South Ward of the City of Springvale.

<i>Name</i>	<i>Address</i>
Bastin, Raymond	1 Red Gum Close, Keysborough
Bastin, Viola	1 Red Gum Close, Keysborough
Bott, Peter	
Deri, Karolj	2 Iron Bark Close, Keysborough
Ferra, Herman	3 Iron Bark Close, Keysborough
Ferra, Maybelle	3 Iron Bark Close, Keysborough
Ferra, Hector	3 Iron Bark Close, Keysborough
Gursoy, Abbas	21 Dryandra Crescent, Keysborough
Hall, Lorna	12 Dryandra Crescent, Keysborough
Isaacs, Hadley	14 Dryandra Crescent, Keysborough
Jacob, Jennifer	15 Dryandra Crescent, Keysborough
Jones, Laraine	1 Iron Bark Close, Keysborough
Keys, Christine	11 Dryandra Crescent, Keysborough
Kun, Laszlo	19 Dryandra Crescent, Keysborough
Marsh, Glenn	17 Dryandra Crescent, Keysborough
McEwan, Stuart	8 Dryandra Crescent, Keysborough
McEwan, Alexander	8 Dryandra Crescent, Keysborough
McEwan, Helen	8 Dryandra Crescent, Keysborough
McNamara, John	10 Dryandra Crescent, Keysborough
Morgan, Constance	3 Dryandra Crescent, Keysborough
Morphet, Margot	9 Dryandra Crescent, Keysborough
Owen, Ian	4 Dryandra Crescent, Keysborough
Pearson, Rosemary	1 Waratah News, Keysborough
Pearson, Amanda	1 Waratah News, Keysborough
Pearson, Jennifer	1 Waratah News, Keysborough
Stapleton, Harry	10 Dryandra Crescent, Keysborough
Thatcher, Shiralee	2 Iron Bark Close, Keysborough
Vize, Frederic	5 Dryandra Crescent, Keysborough
Vize, Isobel	5 Dryandra Crescent, Keysborough

Dated 28 July 1987

Responsible Minister:

J. L. SIMMONDS

Minister for Local Government

L. A. FISHER

Acting Clerk of the Executive Council

*Local Government Act 1958*  
SHIRE OF SWAN HILL

Direction for Corrections to be made to the 1986-87 Voters' Roll

The Governor in Council, acting under section 90 of the *Local Government Act 1958*, directs that the following corrections be made to the Voters' Roll for the North, East and West Ridings of the Shire of Swan Hill.

List of Names to be added to the Voters' Roll for East Riding and deleted from Voters' Roll for North Riding

<i>Name</i>	<i>Address</i>
Treseder, Bernard Murray	Lot 40F, PH Tyntynder West, Nyah West, 3595
Treseder, Margaret Elaine	Lot 40F, PH Tyntynder West, Nyah West, 3595
Treseder, Rhys Martin	Lot 40F, PH Tyntynder West, Nyah West, 3595

List of Names to be added to the Voters' Roll for West Riding and deleted from Voters' Roll for North Riding

<i>Name</i>	<i>Address</i>
Rogers, Aileen Patricia	Wood Wood, 3596
Rogers, Lyn Maree	Wood Wood, 3596
Rogers, Michael John	Wood Wood, 3596
Rogers, Noel Patrick	Wood Wood, 3596

Dated 28 July 1987

Responsible Minister:

J. L. SIMMONDS

Minister for Local Government

A. FISHER

Acting Clerk of the Executive Council

*Local Government Act 1958*

DIRECTION FOR CORRECTIONS TO BE MADE TO THE 1986-87 VOTERS' ROLL—SHIRE OF FLINDERS

The Governor in Council, acting under section 90 of the *Local Government Act 1958*, directs that the following corrections contained in Schedule A be made to the voters roll for the Shire of Flinders.

Schedule A

<i>Riding</i>	<i>Roll No.</i>	<i>Name</i>	<i>Address</i>
Bowen	14868	Callander, Merlyn F.	1807 Nepean Hwy, West Rosebud
	14869	Callander, Thomas D.	1455 Nepean Hwy, Rosebud
Collins	12055	Bucknell, Alan N.	94 Franklin Road, Portsea
	12056	Davis, Brian M.	3808 Nepean Hwy, Portsea
	12057	Davison, Jonathon D.	3568 Nepean Hwy, Sorrento
	12058	Harper, Heather A.	2 Roseville Avenue, Blairgowrie
	12059	Kimpton, Rodger J.	12 Martins Road, Portsea
	12060	McNamara, Kenneth J.	55 Macfarlan Avenue, Blairgowrie
	12061	Massoni, Vivienne	11 Leyden Avenue, Portsea
	12062	O'Callaghan, Peter D.	67 Blair Road, Portsea
	12063	Palmer, Alan A.	334 Hotham Road, Portsea
	12064	Ramsay, John W.	9 Wattle Grove, Portsea
12065	Rennie, John R.	3675 Nepean Hwy, Portsea	
12066	Taylor, Jillian M.	16 Welbeck Avenue, Sorrento	

2028 G 29 29 July 1987

Victoria Government Gazette

	12067	Wertheimer, John	1 Russell Crescent, Sorrento
	12068	Whelan, Myles J.	35 MacGregor Avenue, Portsea
	12069	Whelan, Owen J.	8 Iluka Court, Sorrento
	12070	Wilson, Geoffrey McK.	17 Welbeck Avenue, Sorrento
Matthew	10575	Komesaroff, Morris	68 Marine Parade, Shoreham
	10576	Maw, Ian W.	6 Steane Avenue, Dromana
	10577	Mayes, Marilyn	17 Spindrift Avenue, Flinders
Murray	12375	Allison, Robert C.	123 Jetty Road, Rosebud
	12376	Callander, Merlyn F.	889 Nepean Hwy, Rosebud
	12377	Maw, Alan T.	819 Nepean Hwy, Rosebud

Dated 28 July 1987

Responsible Minister:

J. L. SIMMONDS

Minister for Local Government

L. A. FISHER

Acting Clerk of the Executive Council

*Local Government Act 1958*

SHIRE OF FLINDERS

Direction for Corrections to be made to the 1986-87 Voters' Roll

The Governor in Council, acting under section 90 of the *Local Government Act 1958*, directs that the following corrections be made to the Voters' Roll for the Collins Riding of the Shire of Flinders.

List of Names to be added to the Voters' Roll for Collins Riding

<i>Name</i>	<i>Address</i>
Cormack, Geoffrey F.	6 Tarakan Street, Sorrento

Dated 28 July 1987

Responsible Minister:

J. L. SIMMONDS

Minister for Local Government

L. A. FISHER

Acting Clerk of the Executive Council

*Local Government Act 1958*

CITY OF FITZROY

Direction for Corrections to be made to the 1987/88 Voters' Roll

The Governor in Council, acting under section 90 of the *Local Government Act 1958*, directs that the corrections contained in Schedules A, B and C and lodged at the office of the Director-General for Local Government, 480 Collins Street, Melbourne and at the office of the City of Fitzroy, 201 Napier Street Fitzroy be made to the Voters' Rolls for the Clifton, North and South Wards of the City of Fitzroy.

Dated 28 July 1987

Responsible Minister:

J. L. SIMMONDS

Minister for Local Government

L. A. FISHER

Acting Clerk of the Executive Council

*Local Government Act 1958*

DIRECTION FOR CORRECTIONS TO BE MADE TO THE 1986-87 VOTERS' ROLL—  
CITY OF SPRINGVALE

The Governor in Council, acting under section 90 of the *Local Government Act 1958* directs that the following corrections contained in Schedules A, B, C and D and lodged at the office of the Director-General for Local Government at 480 Collins Street, Melbourne and at the office of the City of Springvale, Springvale Road, be made to the voters' rolls for the South, East, North and Central Wards of the City of Springvale.

Dated 28 July 1987

Responsible Minister:

J. L. SIMMONDS

Minister for Local Government

L. A. FISHER

Acting Clerk of the Executive Council

*Local Government Act 1958*  
**DIRECTION FOR CORRECTIONS TO BE  
 MADE TO THE 1986-87 VOTERS' ROLL—  
 SHIRE OF FLINDERS**

The Governor in Council, acting under section 90 of the *Local Government Act 1958* directs that the following corrections be made to the voters' roll for the Shire of Flinders:

List of Names to be included in the Voters' Roll for the Collins Riding of the Shire of Flinders

<i>Name</i>	<i>Address</i>
Read, Robin Scott	25 James St, Sorrento

Dated 28 July 1987

Responsible Minister:

J. L. SIMMONDS

Minister for Local Government

L. A. FISHER

Acting Clerk of the Executive Council

*Local Government Act 1958*  
**DIRECTION FOR CORRECTIONS TO BE  
 MADE TO THE 1986-87 VOTERS' ROLL—  
 SHIRE OF SOUTH GIPPSLAND**

The Governor in Council, acting under section 90 of the *Local Government Act 1958* directs that the following corrections be made to the voters' roll for the Shire of South Gippsland:

List of Names to be included in the Voters' Roll for the West Riding of the Shire of South Gippsland

<i>Name</i>	<i>Address</i>
Pilkington, Stephen Thomas	"Gyndanook", Sandy Point

Dated 28 July 1987

Responsible Minister:

J. L. SIMMONDS

Minister for Local Government

L. A. FISHER

Acting Clerk of the Executive Council

*Local Government Act 1958*  
**SHIRE OF KORUMBURRA**

Direction for Corrections to be made to the 1987/88 Voters' Roll

The Governor in Council, acting under section 90 of the *Local Government Act 1958*, directs that the corrections contained in Schedule A be made to the Voters' Rolls for the South and Central Ridings of the Shire of Korumburra.

**Schedule A**

List of Names of Voters to be added to the Municipal Roll in the Shire of Korumburra for the following ridings:

**Central Riding:**

5a: ANDRONICO, Annunziata; Rudds Road, Korumburra. (Non-naturalised resident voter.)

36a: BRUZZESE, Annunziata; 59 Mine Road, Korumburra. (Non-naturalised resident voter.)

36b: BRUZZESE, Michele; 59 Mine Road, Korumburra. (Non-naturalised resident voter.)

157a: NOBILE, Carmeto; 19 Guys Road, Korumburra. (Non-naturalised resident voter.)

157b: NOBILE, Natalina; 12 Princes Street, Korumburra. (Non-naturalised resident voter.)

157c: NOBILE, Vincenza; 19 Guys Road, Korumburra. (Non-naturalised resident voter.)

179a: REALE, Concetta; 21 Guys Road, Korumburra. (Non-naturalised resident voter.)

179b: REALE, Franco; 21 Guys Road, Korumburra. (Non-naturalised resident voter.)

**South Riding:**

58a: FAVA, Rosa; Jumbunna Road, Korumburra. (18 year old resident voter.)

76a: GRENON, Jean-Paul; La Fernon Charolais Stud, Jeetho. (Non-naturalised resident voter.)

176a: MORRIS, Joan Elizabeth; P.O. Box 243, Korumburra. (Non-resident voter omitted in error.)

191a: PATTEN, Henry Robert; RMB 3505, Warragul Road, Korumburra. (Non-resident voter omitted in error.)

286a: WOOLLEY, David James; 12 Bourke Street, Korumburra. (Non-resident voter omitted in error.)

290a: WYATT, Lester Charles; Fairbank Road, Arawata. (Non-resident voter omitted in error.)

Dated 28 July 1987

Responsible Minister:

J. L. SIMMONDS

Minister for Local Government

L. A. FISHER

Acting Clerk of the Executive Council

*Local Government Act 1958*  
**CITY OF KEILOR**

Direction for Corrections to be Made to the 1987-88 Voters' Roll

The Governor in Council, acting under section 90 of the *Local Government Act 1958*, directs that the corrections contained in Schedules A, B and C and lodged at the office of the Director-

General for Local Government, 480 Collins Street, Melbourne and at the office of the City of Keilor, Calder Highway, Keilor be made to the voters' rolls for the Maribyrnong, Niddrie and Doutta Galla/Tullamarine Wards of the City of Keilor.

Dated 28 July 1987

Responsible Minister:

J. L. SIMMONDS

Minister for Local Government

L. A. FISHER

Acting Clerk of the Executive Council

*Water and Sewerage Authorities (Restructuring) Act 1983*

**SHIRE OF BACCHUS MARSH**

Extent of Water Supply District Increased

The Governor in Council, under the provisions of the *Water and Sewerage Authorities (Restructuring) Act 1983*, approves of the extension of the Bacchus Marsh Water Supply District of the Shire of Bacchus Marsh as shown by the pink shading on the accompanying plan—(Corr. No. 84/2185).

Dated 2 June 1987

Responsible Minister:

ANDREW McCUTCHEON

Minister for Water Resources

E. M. MILLER

Acting Clerk of the Executive Council

*Water and Sewerage Authorities (Restructuring) Act 1983*

*Water Act 1958*

**MORWELL WATER BOARD**

Transfer of Works of Water Supply

Under the powers conferred by the *Water and Sewerage Authorities (Restructuring) Act 1983* and *Water Act 1958* and all other powers enabling him in that behalf, His Excellency the Governor of Victoria approves the transfer from the Latrobe Valley Water and Sewerage Board to the Morwell Water Board of the Saline Water Pipeline located between the Latrobe Valley Water and Sewerage Board's outfall sewer and the Hazelwood Power Station in accordance with the attached agreement—(Corr. No. 84/2776/73).

Dated 2 June 1987

Responsible Minister:

ANDREW McCUTCHEON

Minister for Water Resources

E. M. MILLER

Acting Clerk of the Executive Council

*Water and Sewerage Authorities (Restructuring) Act 1983*

*Sewerage Districts Act 1958*

**MORNINGTON PENINSULA AND DISTRICT WATER BOARD**

Compulsory Acquisition of Easement Approved

The Governor in Council, under the provisions of the *Water and Sewerage Authorities (Restructuring) Act 1983* and the *Sewerage Districts Act 1958* approves of the compulsory acquisition of an easement for the Mornington Peninsula and District Water Board as shown in yellow on the accompanying plan—(Corr. No. 79/845/89).

Dated 2 June 1987

Responsible Minister:

ANDREW McCUTCHEON

Minister for Water Resources

E. M. MILLER

Acting Clerk of the Executive Council

*Water and Sewerage Authorities (Restructuring) Act 1983*

*Water Act 1958*

**PYALONG WATER BOARD**

Sites of Water Storage Access and Pipelines Approved

The Governor in Council, under the provisions of the *Water and Sewerage Authorities (Restructuring) Act 1983* and the *Water Act 1958* approves of the sites of a water storage, access and pipelines as shown in brown and yellow on the accompanying plan—(Corr. No. 81/3357/51).

Dated 2 June 1987

Responsible Minister:

ANDREW McCUTCHEON

Minister for Water Resources

E. M. MILLER

Acting Clerk of the Executive Council



## TENDERS

### PUBLIC WORKS DEPARTMENT

Tenders are invited for the purposes indicated hereunder and will be received at 2 Treasury Place, Melbourne, 3002, until TWO p.m. on the dates shown.

Tenders must be addressed to the Minister for Public Works with the envelope endorsed "Tender for \_\_\_\_\_".

Tenders forwarded either by mail, telegram or telex, which arrive after the closing time, will be accepted provided that the official Telecom or Australia Post time and date stamping indicates dispatch prior to the closing time. (TIME AND DATE STAMPING MUST BE REQUESTED AT SOME POST OFFICES.)

(TELEX No. AA152039)

Hand-delivered tenders must be placed in the Department's tender box, in foyer, Ground Floor, 2 Treasury Place, Melbourne.

Tender documents are available from the Contracts Office, Room 29, Ground Floor, 2 Treasury Place, Melbourne and where indicated, at offices of Inspector of Works.

Wednesday, 5 August 1987

**Building, Electrical and Mechanical Services etc.**

**MARYBOROUGH**—Conversion of relocatable classroom to a canteen facility, Technical College. (W.O. Bendigo).

**MITCHAM**—Fitting out works to 1st Floor, 329 Mitcham Road—Community Health Services Clinic.

**SUNBURY**—Paving works, Caloola Training Centre.

Wednesday, 12 August 1987

**Building, Electrical and Mechanical Services etc.**

**BEECHWORTH**—Upgrade of staff/administration facilities, Primary School. (W.O. Wangaratta).

**KURUNJANG**—*Re-advertised:* Floor finishes, Stage 2, Blocks 1 and 2, Post Primary School.

**MORNINGTON**—New covered ways and ramps, Special Development School. (W.O. Mornington).

**PORT MELBOURNE**—Contract 1, 87/88: Supply and delivery of relocatable modular buildings at rates, F.O.G., P.W.D. Storeyard—69 Salmon Street. (W.O. Bendigo and Ballarat).

**WATTLE PARK**—External repairs and painting, High School.

### Miscellaneous

**GLEN WAVERLEY**—Supply of passive infrared detectors, T1414, Security Services, Education Department.

**PORT MELBOURNE**—Supply of tote boxes, T3598, P.W.D. Storeyard, 69 Salmon Street.

Wednesday, 19 August 1987

**Building, Electrical and Mechanical Services etc.**

**FERNTREE GULLY NORTH**—Repairs and painting and re-roofing, Primary School.

**MELBOURNE**—Fitting out works to Levels 8 and 21, Nauru House, 80 Collins Street, Department of Labour.

**MELBOURNE**—Computer site works and uninterrupted power supply, 471 Little Bourke Street, Attorney-General's Department.

**PARKMORE**—Internal and external repairs and painting, Primary School.

RONALD W. WALSH  
Minister for Public Works

Public Works Department  
Melbourne, 20 July 1987

### STATE TENDER BOARD CONTRACTS ACCEPTED Amendments

Schedule Number	Item Number	New Rate	Effective Date
\$			
<i>Photographic and X-Ray Equipment</i>			
1/55	46	10.14	3.8.87
	47	101.24	
	48	28.13	
	49	153.93	
	56	1365.35	
	58	2.27	
	59	3.28	
	60	2.51	
	82	4.60	
	87	3.35	
	88	5.69	
	89	17.86	
	91	4.28	
	92	3.04	
	93	34.79	
	105	20.74	
	115	19.81	
	116	16.06	
	117	3.35	

118	19.81	224	List	
119	30.57		2.3.87	
120	15.83		less 22%	
121	5.26	232	8.42	
122	19.81	233	45.40	
123	74.92	234	108.80	
124	2.80	235	45.40	
125	2.80	* Delete: 25 litre pack size		
126	2.94	Add: 35 litre pack size		
127	3.74	<i>Hand Tools (General)</i>		
129	2.57	1/56	44	P & N 3.8.87
130	3.23			Wiltshire
131	4.33			List 1
139	6.53			May 1987
140	9.68			Less 44.5%
144	7.44	<b>J. M. PAWSON</b>		
145	4.10	<b>Secretary to the Tender Board</b>		
146	22.18	<b>STATE TENDER BOARD</b>		
148	7.44	Registration of Interest		
149	18.22	Photocopying Machines		
150	22.18	Expression of interests are invited for the		
151	6.53	supply of photocopying machines and		
152	9.68	consumables to the Victorian Government for		
153	11.08	the period commencing 1 August 1988.		
154	8.77	Companies wishing to register an interest are		
155	22.18	requested to forward relevant details and		
156	8.77	brochures of their range of photocopying		
157	99.25	machines to—		
158	22.19	Secretary, State Tender Board, 49 Spring Street,		
159	5.31	Melbourne, Vic., 3000—		
160	7.46	no later than 8.30 a.m. Friday, 31 July 1987.		
161	5.65	All responses must be clearly marked		
172	11.39	"Expression of Interest to Supply Photocopying		
173	40.48	Machines and Consumables to the Government		
174	5.85	of Victoria".		
175	46.91	Full particulars and any information may be		
176	11.55	obtained from the office of the Tender Board		
199	24.98	(Telephone—651 3266).		
201	16.13*	5.8.87	<b>P. G. FIELD</b>	
211	7.91	3.8.87	<b>Acting Secretary to the Tender Board</b>	
212	6.43			
213	5.92			
214	12.79			
218	7.40			
219	List			
	2.3.87			
	less 22%			
220	27.69			
221	List			
	2.3.87			
	less 22%			

**PRIVATE NOTICES**

**CITY OF WERRIBEE**

**Right of Way Discontinuance**

Notice is hereby given pursuant to section 528 (2) of the *Local Government Act 1958*, the Council of the City of Werribee, after consultation with Public Authorities and the advertising of its intention and notification to the registered proprietors of the land and owners and occupiers of any land abutting the right of way has by resolution of its Ordinary Meeting held on 6 July 1987 as follows:

- (a) That the right of way north of Central Avenue, south of Alma Avenue, between

SCHEME 41  
Scale 1/100.

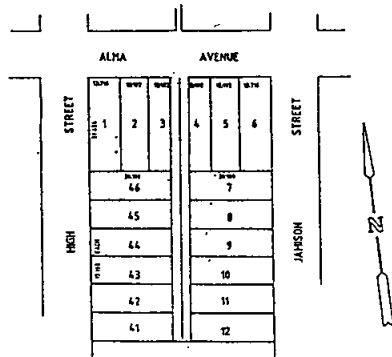

High Street and Jamison Street shown hatched on the plan hereunder shall be discontinued.

- (b) That the land in the discontinued right of way shall be sold and transferred to the abutting owners by private treaty.

J. T. KERR  
Town Clerk

7928

**SHIRE OF CRANBOURNE**  
**Declaration of Drainage Courses**

The Shire of Cranbourne, pursuant to section 38 of the *Drainage of Land Act 1975*, has applied to the Minister for Water Resources to declare the Pearceedale Outfall Drains as drainage courses.

The outfall drains are shown on the plan numbered D87-4 which is exhibited at the Municipal Offices, Sladen Street, Cranbourne, during normal office hours.

Inspection of the plan is invited. Any objections to the making of the declaration should be in writing and addressed to the Chief Executive, Shire of Cranbourne, P.O. Box 4, Cranbourne, 3977. Objections will be accepted up until Wednesday, 26 August 1987.

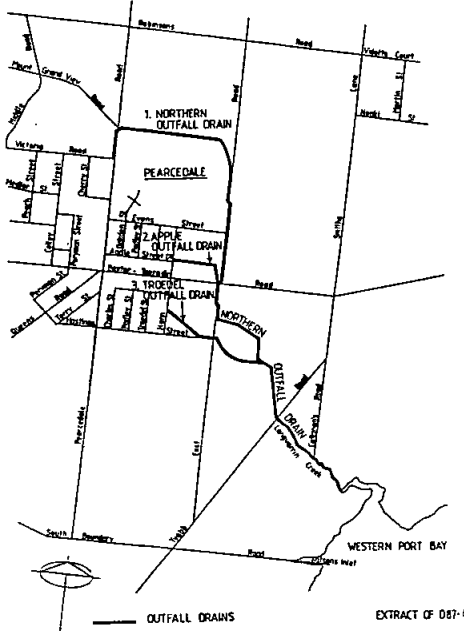

EXTRACT OF D87-4

T. VICKERMAN  
Chief Executive

7929

**CITY OF GEELONG**

**Loan No. 70**

Melbourne and Geelong Debentures Inscribed  
Stock and Mortgages Acts

Notice is hereby given that the Council of the City of Geelong intends to borrow the principal sum of \$82 000 for the purpose of road reconstruction works in Rock O'Cashell Lane and Union Street, Geelong. The period of the loan shall be four years due 31 August 1991 after which date the term of the loan may be extended in consecutive four year periods to a total of 10 years. Repayments of the loan will be by equal half yearly instalments based on a 10 year repayment schedule. The rate of interest payable during the initial four year period will be 14.5 per cent per annum.

T. J. T. NEAL  
Town Clerk and Chief  
Administrative Officer

8006

**Sewerage Districts Act 1958  
SHIRE OF WARRNAMBOOL**

**Proposed Sewerage Works Koroit**

Notice is hereby given that the Shire of Warrnambool has made application to the Honourable the Minister for Water Resources for submission to the Governor in Council for his sanction for the proclamation of the Koroit Sewerage District and the construction maintenance and continuance of the proposed sewerage works.

A general plan and description of the proposed works have been forwarded with the application and copies of all such documents have been deposited and may be inspected at the Shire office, 99 Fairy Street, Warrnambool, the office of the Minister for Water Resources 590 Orrong Road, Armadale and the office of the Health Department Victoria, 555 Collins Street, Melbourne.

R. E. HARDISTY  
Acting Shire Secretary

7790

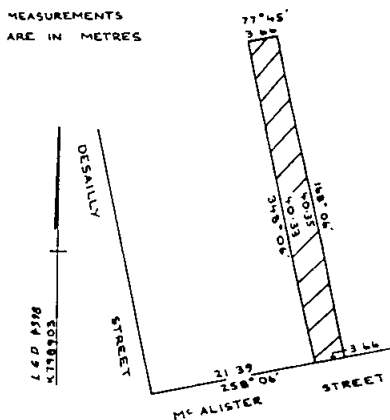

JOHN L. LOW  
Town Clerk

8005

**Form 2.1**

**Town and Country Planning Act 1961  
CITY OF TRARALGON PLANNING  
SCHEME 1957**

Notice that a Planning Scheme has been Prepared and is Available for Inspection  
Amendment No. 90

Notice is hereby given that the City of Traralgon in pursuance of its powers under the *Town and Country Planning Act 1961* has prepared a scheme for land being 29, 39 and 41 Breed Street, Lots 17, 21 and 23, section 10A, Block 3, Lodged Plan 1767, Parish and City of Traralgon.

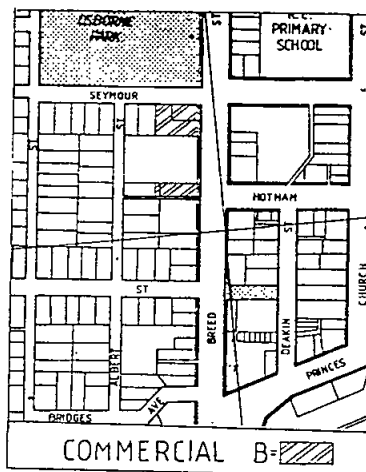

**CITY OF SALE**

**Discontinuance of Road**

Notice is hereby given that in accordance with section 528 (2) of the *Local Government Act 1958*, the City of Sale has resolved that the road shown hatched below, known as "Campbell's Lane" having a 3.66 metre frontage to Macalister Street by a depth of 40.35 metres and which lies between the following properties:

- (i) Part of Crown Allotment 10, section 4, Town and Parish of Sale and being the whole of the land contained in Certificate of Title Volume 2105, Folio 911 (Desailly C/R Macalister Streets);
- (ii) Part of Crown Allotment 10, section 4, Town and Parish of Sale and being the whole of the land contained in Certificate of Title Volume 6367, Folio 344 (Victoria Hall site, Macalister Street)—is not reasonably required as a road for public use and that the Council has resolved to discontinue and sell the said road by agreement.

Now therefore the Council of the City of Sale hereby directs:

- (a) That the said road which is shown hatched below shall be discontinued upon publication of resolution in the *Government Gazette*;
- (b) That subject to any such right, title, power, authority or interest in the land the said road shall be sold by agreement.

The Amendment proposes to rezone land from Residential 'B' to Commercial 'B' and proposes ordinance changes restricting development to the following uses:

- Amenity Building
- Car Park
- Commercial Premises
- Office of Professional Person and Public Building

A copy of the scheme has been deposited at the Municipal Offices, Kay Street, Traralgon and at the Regional Office of the Ministry for Planning and Environment, 71 Hotham Street, Traralgon and at the office of the Ministry for Planning and Environment, The Olderfleet Buildings, 477 Collins Street, Melbourne, and will be open for inspection during office hours by any person free of charge.

Any persons affected by the scheme are required to set forth in writing any submissions they may wish to make with respect to the scheme addressed to Chief Executive/Town Clerk, City of Traralgon, Municipal Offices, Kay Street, Traralgon, 3844 by 29 August 1987 and state whether you wish to be heard in respect of your submission.

Dated 21 July 1987

8007 JOHN L. MITCHELL  
Chief Executive/Town Clerk

**CITY OF BOX HILL**

Notice of Road Discontinuance Pursuant to Paragraph 528 (2) (a) of the *Local Government Act 1958*

The Council of the City of Box Hill at its meeting on 17 September 1984 made the following resolution:

1. "The Council, being of the opinion that the road delineated and hatched on the plan herunder being Part of Plan of Subdivision Nos. 1468 and 29007 is not reasonably required as a road for public use, hereby directs that the road be discontinued and retained by the City of Box Hill for municipal purposes.

2. Notwithstanding the discontinuance of the Road the MMBW shall continue, and where necessary, shall be deemed to have continued to have and possess the same right, title, power and authority or interest in or in relation to the road or any part of the road with respect to or in connection with any drains and pipes laid or erected in, on or over the road or part of the road for the purpose of drainage and sewerage or other like purposes as existed prior to the discontinuance of the road in accordance with paragraph 528 (2) (e) of the Act."

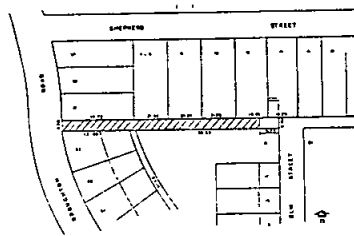

8008 I. G. PORT  
Town Clerk

**Form 2.1**

*Town and Country Planning Act 1961*  
**SHIRE OF FLINDERS PLANNING  
SCHEME, 1962**

Notice that a Planning Scheme has been Prepared and is Available for Inspection  
Amendment No. 228, 1987

Notice is hereby given that the Council of the Shire of Flinders in pursuance of its powers under the *Town and Country Planning Act 1961* has prepared a scheme for the area being Part CA.146, Parish of Nepean, 3790 Nepean Highway, Portsea to designate this land as being subject to the provisions of Clause 5.04—Historic Site Policy of the Shire of Flinders Planning Scheme, 1962 and to include Part CA.146, Parish of Nepean, 3790 Nepean Highway, Portsea, Title Volume 6250, Title Folio 995 as a historic building in the table to Clause 5.04.

A copy of the amendment has been deposited at the office of the Shire of Flinders, Boneo Road, Rosebud, and at the office of the Ministry for Planning and Environment, The Olderfleet Buildings, 477 Collins Street, Melbourne, and will be open for inspection during office hours by any person free of charge.

Any persons affected by the amendment are required to set forth in writing any submission they may wish to make with respect to the amendment addressed to The Chief Executive, Shire of Flinders, P.O. Box 1000, Rosebud, by 31 August 1987 and state whether you wish to be heard in respect of your submission.

Dated 29 July 1987

8009 LARRY M. JONES  
Shire Secretary

**SHIRE OF BACCHUS MARSH**

Change of Street Name  
View Street to Somerton Court

Notice is hereby given that at the Council Meeting held on 16 July 1987, Council resolved

to name View Street, hatched on the plan hereunder, Somerton Court.

This change will come into effect on the date of publication in the *Government Gazette*, being Wednesday, 29 July 1987.

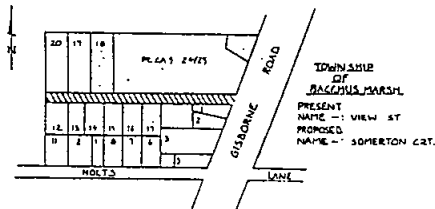

8010

IAN D. MORRIS  
Shire Secretary

required as a road for public use, be discontinued and that the land be sold by private treaty.

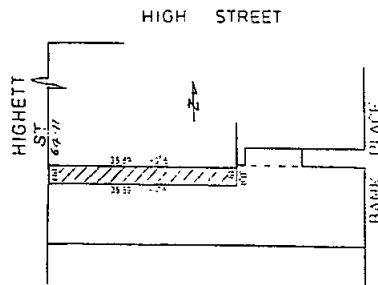

88015

F. WALSHE  
Shire Secretary

**SHIRE OF McIVOR**  
Streets and Roads

Notice is hereby given pursuant to the provisions of the *Local Government Act 1958*, as amended, that the Council of the Shire of McIvor resolved at its meeting held on 9 July 1987 to assign the following name to the unnamed Government roads as stated hereunder:

Name	Location
Westblade Street	The unnamed road/lane that extends in an easterly direction to Valley Road adjacent to C.A. 4 and 5, section 28, Township of Mia Mia, Parish of Spring Plains.
McKindlay Street	The unnamed road/lane that extends in an north/southerly direction to C.A. 2, 3 and 4, section 28, Township of Mia Mia, Parish of Spring Plains.

Dated 14 July 1987

8014

D. J. MONTGOMERY  
Shire Secretary

**SHIRE OF MANSFIELD**  
Road Discontinuance

Notice is hereby given that in accordance with the provisions of section 528 (2) (a) of the *Local Government Act 1958*, the Council of the Shire of Mansfield on 14 July 1987 resolved as follows:

That the part of the roadway between Highett Street and Bank Place, Mansfield, hatched below, being in the opinion of Council not reasonably

**SHIRE OF VIOLET TOWN**  
Naming of Street

Notice is hereby given that in accordance with the provisions of section 535 (4) of the *Local Government Act 1958* the Council of the Shire of Violet Town, at the Meeting held on 13 July 1987, resolved to assign the name—"Meadows Lane"—to the unnamed road running South from Footers Road adjacent to C.A.s 3, 4A and 5, Parish of Marraweeny.

8016

J. R. KYLE  
Shire Secretary

**SHIRE OF DIMBOOLA**

Declaration of Land as a Public Highway

Pursuant to the provisions of section 522 of the *Local Government Act 1958*, the Council of the Shire of Dimboola hereby directs that the land being part of Crown Allotment 35A, Parish of Tullyvea indicated by hatching on the diagram hereunder which has been purchased taken or acquired by it shall be a public highway on and from the date of publication of this order in the *Government Gazette*.

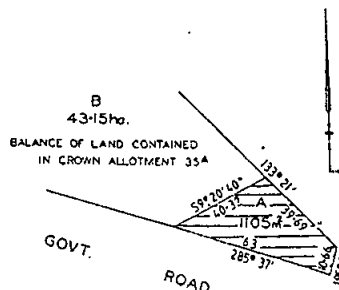

The Common Seal of the President, Councillors and Ratepayers of the Shire of Dimboola was hereunto affixed 21 July 1987 in the presence of:

KEN G. SLEEP, Shire President  
 SHIRLEY WILSON, Councillor  
 8012 BRIAN MOLONEY, Shire Secretary

(d) hereafter, subject to any such right, title, power, authority or interest, the said part be sold to abutting owners by private treaty.

**SHIRE OF WANGARATTA**  
 By-Law No. 35  
 Caravan By-Law

Notice is hereby given that the Council of the Shire of Wangaratta has made a By-Law No. 35 under the provisions of the *Local Government Act 1958* for the purpose of prohibiting or regulating the placing of Caravans on private property.

A copy of the By-Law is open for inspection free of charge during office hours at the Shire Offices, 23 Ely Street, Wangaratta.

8013 D. R. SHARP Shire Secretary

**CITY OF SUNSHINE**  
 Road Discontinuance

Pursuant to section 528 (2) of the *Local Government Act 1958*, the Council of the City of Sunshine passed the following resolution at its Ordinary Meeting held on 9 June 1987.

This Council, being of the opinion that the part of the road shown enclosed by continuous thick lines on the plan hereunder is not reasonably required as a road for public use, having consulted with any relevant public statutory authority, having published and given notices required by section 528 (2) of the *Local Government Act 1958* and having considered any objections to the proposal, does hereby resolve and direct that:

- (a) such part be discontinued;
- (b) that notwithstanding such discontinuance, the Melbourne and Metropolitan Board of Works shall continue to have and possess the same right, title, power, authority or interest in or in relation to the whole of the land shown enclosed by continuous thick lines on the said plan as it had or possessed prior to such discontinuance with respect to or in connection with any drains or pipes laid or erected in, on or over such land for the purposes of drainage or sewerage;
- (c) publication of this resolution be effected in the *Government Gazette*; and

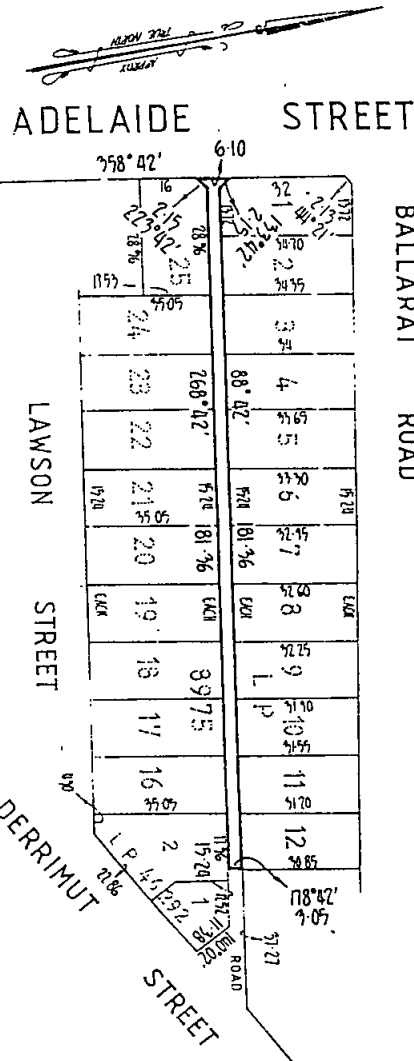

**SHIRE OF BASS**  
Short Street, San Remo

Notice is hereby given that the Council of the Shire of Bass, having complied with the provisions of section 528 of the Local Government Act passed the following motion at its meeting on 4 May 1987.

That pursuant to section 528 of the Local Government Act, Council being of the opinion that the section of roadway shown hatched on the plan annexed hereto is not reasonably required for public purposes resolves that it be discontinued and sold by private treaty.

PLAN FOR CLOSURE OF ROAD  
PART OF CROWN ALLOTMENT 6A  
TOWNSHIP OF SAN REMO  
PARISH OF WOOLAMAI  
COUNTY OF MORNINGTON

SCALE 1:1500  
5 0 5 10 15 20  
LOWERING ARE IN METRES

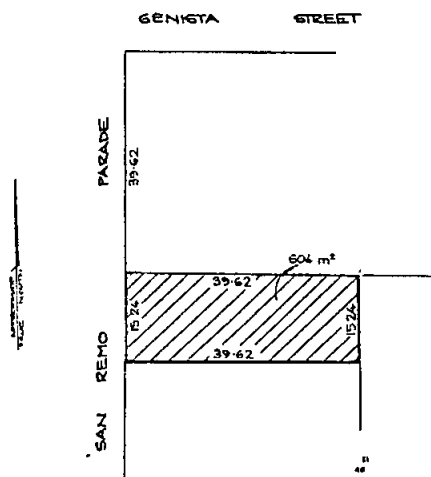

ROAD TO BE CLOSED SHOWN WITH [Hatched Pattern]

PART OF LOT VOL. 8222, FOL. 393

8040

G. J. HARLAND  
Shire Manager

**CITY OF DONCASTER AND  
TEMPLESTOWE**

**Sale Unnecessary Road—Bulleen Road,  
Bulleen**

Pursuant to section 528 of the Local Government Act 1958, the Council of the City of Doncaster and Templestowe at the meeting on 7 July 1987 resolved that:

Council, having complied with the provisions of section 528 (2) (a) of the Local Government Act 1958 and having received no objections under section 193 (A) of the Local Government Act 1958 to the proposal to close and sell by private treaty that part of the Bulleen Road Reserve opposite Lot 1, LP 89295, hereby resolves that that part of the Road Reserve shown on the plan hereunder be sold by private treaty to the abutting owner of Lot 1, 89295, the Veneto Social Club Melbourne.

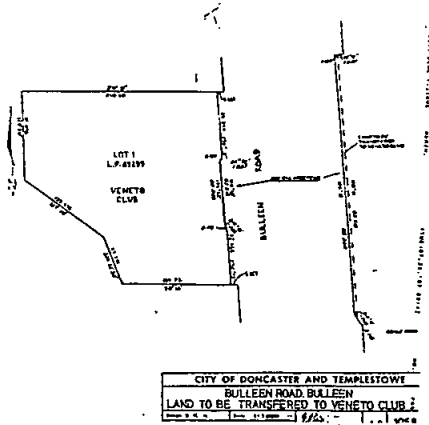

CITY OF DONCASTER AND TEMPLESTOWE  
BULLEEN ROAD, BULLEEN  
LAND TO BE TRANSFERRED TO VENETO CLUB

8080

G. J. MORTON  
Town Clerk

**CITY OF CAMBERWELL**  
Road Discontinuance

Pursuant to section 528 (2) of the Local Government Act 1958, the Council of the City of Camberwell has resolved that part of a road at the rear of Howie, Renwick and Goodwin Streets, Glen Iris, which is shown by hatching on the plan herewith, and which has been closed per Amendment 408, Melbourne, Metropolitan Planning Scheme, gazetted 25 June 1986 be discontinued, subject to—

- (a) the Melbourne and Metropolitan Board of Works continuing to have and possess the same right, title, power, authority or



interest in or in relation to the whole of the land shown by hatching on the said plan as it had or possessed prior to such discontinuance with respect to or in connection with any drains or pipes laid or erected in on or over such land for the purposes of drainage or sewerage;

- (b) the City of Camberwell continuing to have and possess the same right, title, power, authority or interest in or in relation to the whole of the land shown by hatching on the said plan as it had or possessed prior to such discontinuance with respect to or in connection with any drains or pipes laid or erected in on or over such land for the purposes of drainage or sewerage;
- (c) the land in the said road subject to any such right, title, power, authority or interest vesting in the municipality to be retained by it until sold by private treaty.

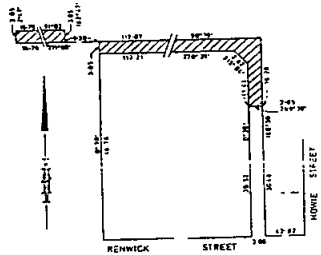

**MARTIN VERHOEVEN**  
8038 Chief Executive Officer and Town Clerk

**SHIRE OF BET BET**  
Naming of Streets and Roads

Notice is hereby given pursuant to the provisions of the *Local Government Act 1958*, as amended, that the Council of the Shire of Bet Bet resolved at its Meeting held on 22 July 1987, to assign the following name to the un-named Government Road as stated hereunder:

Name	Location
Brewery Lane	Un-named road/lane located between Crown Allotments 1, 19, 17, 26, 26A, section F, Parish of Tarnagulla.

Dated 27 July 1987

8069 **J. A. THOMPSON**  
Shire Secretary

**SHIRE OF FLINDERS**  
Banksia Wood, Rosebud

Naming of Link Road—Tea Tree Place

At the Meeting held on 22 July 1987 the Council of the Shire of Flinders having undertaken the required statutory procedures pursuant to section 535 (4) of the *Local Government Act 1958* and invited objection pursuant to section 193A of the said Act, resolved to apply the name 'Tea Tree Place' to road as shown on Plan SK.491.

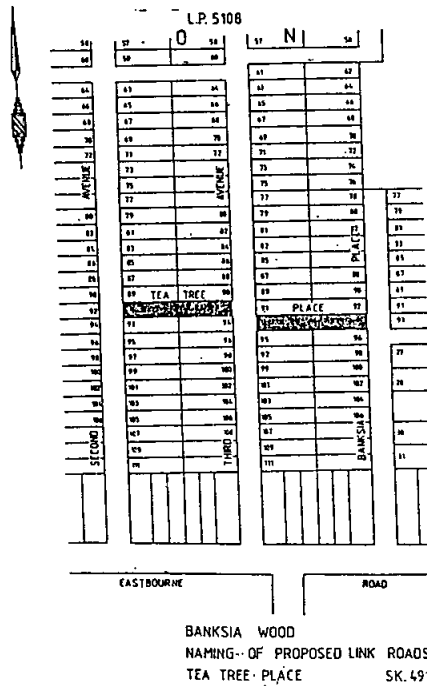

Dated 29 July 1987

8067 **LARRY M. JONES**  
Chief Executive Officer/Shire Secretary

Form 2.1  
*Town and Country Planning Act 1961*  
**SHIRE OF BALLARAT PLANNING SCHEME**

Notice that a Planning Scheme Amendment has been Prepared and is Available for Inspection  
Notice is hereby given that the Shire of Ballarat in pursuance of its powers under the *Town and*

2040 G 29 29 July 1987

Victoria Government Gazette

Country Planning Act 1961 has prepared a scheme to re-zone the land known as:

Nos 914-916 Howitt Street, Wendouree from Residential A to Commercial B.

A copy of the scheme has been deposited at the Shire Offices, Gillies Street, Wendouree, 3355, the Central Highlands Regional Office, Ministry for Planning and Environment, State Offices, Mair Street, Ballarat 3350 and at the office of the Ministry for Planning and Environment, The Olderfleet Buildings, 477 Collins Street, Melbourne 3000 and will be open for inspection during office hours by any person free of charge.

Any persons affected by the scheme are required to set forth in writing any submission they wish to make with respect to the scheme addressed to the Shire Secretary, Shire of Ballarat, Shire Offices, Gillies Street, Wendouree, 3355 by 31 August 1987 and state whether they wish to be heard in respect of their submission.

Dated 23 July 1987

R. H. HOLLIOAKE  
Town Planning Officer

8068

Form 2.1

Town and Country Planning Act 1961

SHIRE OF BACCHUS MARSH PLANNING  
SCHEME

Notice that a Planning Scheme Amendment has been Prepared and is Available for Inspection  
Amendment No. 49

Notice is hereby given that the Shire of Bacchus Marsh in pursuance of its powers under the *Town and Country Planning Act 1961* has prepared a Scheme to change the use "Fuel Depot" from a prohibited use to a Column 4 or Council discretionary use in the Commercial Central, Commercial General and Commercial Local zones of the Planning Scheme.

A copy of the Scheme has been deposited at the Shire Offices of Bacchus Marsh, 197 Main Street, Bacchus Marsh and at the office of the Ministry for Planning and Environment, The Olderfleet Buildings, 477 Collins Street, Melbourne and will be open for inspection during office hours, by any person, free of charge.

Any persons affected by the Scheme are required to set forth in writing any submission they may wish to make with respect to the Scheme, addressed to the Shire Secretary, Shire of Bacchus Marsh, P.O. Box 216, Bacchus Marsh 3340 by 30 August 1987 and state whether they wish to be heard in respect of their submission.

Dated 20 July 1987

8011 D. L. MURPHY Shire Engineer

SHIRE OF BENALLA

Naming of Road

Notice is hereby given that at the meeting on 20 July 1987, Council altered the name of the following road:

Old name: North Benalla-Winton Road from Benalla/Yarrowonga Road to Eleven Mile Creek Road.

New name: Nelson Road.

S. LONDON

8055

Shire Secretary

CITY OF SPRINGVALE

Change of Street Names

Notice is hereby given that pursuant to the powers conferred by section 535 (4) of the *Local Government Act 1958* (as amended), the Council has renamed Coniston Drive and the western end of Treeby Court as Coniston Court, Springvale South.

I. J. TATTERSON

Chief Executive Officer

8039

Town and Country Planning Act 1961

CITY OF WARRNAMBOOL PLANNING  
SCHEME

Notice of a Proposed Amendment to the City of Warrnambool Planning Scheme  
Amendment No. 24

Notice is hereby given that pursuant to subsection 7 of section 32 of the *Town and Country Planning Act 1961*, the Minister has required that the City of Warrnambool give notice of and deposit for inspection by the public for a period of fourteen days, a proposed amendment to the Ordinance of the City of Warrnambool Planning Scheme.

The amendment, known as Amendment No. 24 is to insert a new sub-clause 30 (3) into the Ordinance such that a Motel may be established on property known as 2 Liebig Street, Warrnambool subject to a number of conditions.

The proposed amendment is available for inspection free of charge during office hours at the office of the Council of the City of Warrnambool, Municipal Offices, Liebig Street, Warrnambool, and at the office of the Ministry for Planning and Environment, 477 Collins Street, Melbourne and Room 14, V S & L Building, Liebig Street, Warrnambool.

Any persons affected by the proposed amendment are required to set forth in writing any submission they may wish to make with respect to the proposed amendment addressed

to the Minister for Planning and Environment,  
PO Box 42, Warrnambool, 3280 by 13 August  
1987.

Dated 29 July 1987

V. G. ROBSON  
Town Clerk

City of Warrnambool, Municipal Offices,  
Liebig Street, Warrnambool 8050

Form 2.1

*Town and Country Planning Act 1961*  
SHIRE OF TAMBO (LAKES ENTRANCE)  
PLANNING SCHEME

Notice that a Planning Scheme Amendment has  
been Prepared and is Available for Inspection  
Amendment No. 75

Notice is hereby given that the Shire of Tambo  
in pursuance of its powers under the *Town and  
Country Planning Act 1961*, has prepared a  
Planning Scheme Amendment for the following:

That area situated on the north-east corner of  
McCullough Street and the Princes Highway  
Service Road and being Lots 210 and 211 LP  
53064 Princes Highway, Lakes Entrance to  
rezone from Residential A to Commercial  
Neighbourhood.

A copy of the Scheme has been deposited at  
the Shire Offices, Main Street, Bruthen, and at  
the office of the Ministry for Planning and  
Environment (Plan Inspection Section), Ground  
Floor, The Olderfleet Buildings, 477 Collins  
Street, Melbourne, and will be open for inspection  
during office hours by any person free of charge.

Any persons affected by the Scheme are  
required to set forth in writing any submissions  
they may wish to make addressed to the Chief  
Executive, Shire of Tambo, P.O. Box 10, Bruthen,  
3885, by 2 September 1987 and state whether  
you wish to be heard in respect of your  
submission.

8054 W. J. HOBSON  
Chief Executive

Form 2.1

*Town and Country Planning Act 1961*  
CITY OF MOE PLANNING SCHEME 1966

Notice that a Planning Scheme has been  
Prepared and is Available to Inspection  
Amendment No. 102

Notice is hereby given that the City of Moe in  
pursuance of its powers under the *Town and  
Country Planning Act 1961* has prepared a  
scheme for land being Nos. 54-60 Dinwoodie  
Drive, Moe, being Lots 203-206, LP 142618

(Sheet 2 of 3), part Crown Allotment 5B, Parish  
of Narracan.

The Amendment proposes to rezone land from  
Commercial "A" to Proposed Public Purpose  
Reserve 5—Community Centre.

A copy of the scheme has been deposited at  
the Municipal Offices, Albert Street, Moe and at  
the Regional Office of the Ministry for Planning  
and Environment, 71 Hotham Street, Traralgon  
and at the office of the Ministry for Planning and  
Environment, The Olderfleet Buildings, 477  
Collins Street, Melbourne, and will be open for  
inspection during office hours by any person free  
of charge.

Any persons affected by the scheme are  
required to set forth in writing any submissions  
they may wish to make with respect to the scheme  
addressed to Economic Development and  
Planning Officer, City of Moe, Municipal Offices,  
Albert Street, Moe 3825 by 29 October 1987 and  
state whether you wish to be heard in respect of  
your submission.

Dated 22 July 1987

8049 B. PEACH  
Economic Development and  
Planning Officer

Form 2.1

*Town and Country Planning Act 1961*  
SHIRE OF TAMBO (BALANCE OF SHIRE)

Notice that an Interim Development Order  
Amendment has been Prepared and is Available  
for Inspection

Planning Scheme Interim Development Order  
1985

Amendment No. 17

Notice is hereby given that the Shire of Tambo  
in pursuance of its powers under the *Town and  
Country Planning Act 1961*, has prepared an  
Interim Development Order Amendment for the  
following:

That area situated on the south-western portion  
of the southern end of Curtis Lane and being  
Crown Allotment A3 Parish of Tambo, Mossiface  
Road, Mossiface for a site specific amendment  
to clause 7 of the Ordinance.

A copy of the Order has been deposited at the  
Shire Offices, Main Street, Bruthen, and at the  
office of the Ministry for Planning and  
Environment (Plan Inspection Section), Ground  
Floor, The Olderfleet Buildings, 477 Collins  
Street, Melbourne, and will be open for inspection  
during office hours by any person free of charge.

Any persons affected by the Order are required  
to set forth in writing any submissions they may  
wish to make addressed to the Chief Executive,

Shire of Tambo, P.O. Box 10, Bruthen, 3885, by 2 September 1987 and state whether you wish to be heard in respect of your submission.

8051 W. J. HOBSON  
Chief Executive

## Form 2.1

*Town and Country Planning Act 1961*  
SHIRE OF TAMBO (BALANCE OF SHIRE)

Notice that an Interim Development Order Amendment has been Prepared and is Available for Inspection

Planning Scheme Interim Development Order  
1985

## Amendment No. 18

Notice is hereby given that the Shire of Tambo in pursuance of its powers under the *Town and Country Planning Act 1961*, has prepared an Interim Development Order Amendment for the following:

That area situated on the east side of Kalimna West Road directly south of the Kalimna West Primary School and being Crown Allotment 100A, Kalimna West Road, Kalimna West for an amendment to clause 7 of the ordinance to include a site specific clause to allow a 2 lot subdivision

A copy of the Order has been deposited at the Shire Offices, Main Street, Bruthen, and at the office of the Ministry for Planning and Environment (Plan Inspection Section), Ground Floor, The Olderfleet Buildings, 477 Collins Street, Melbourne, and will be open for inspection during office hours by any person free of charge.

Any persons affected by the Order are required to set forth in writing any submissions they may wish to make addressed to the Chief Executive, Shire of Tambo, P.O. Box 10, Bruthen, 3885, by 2 September 1987 and state whether you wish to be heard in respect of your submission.

8052 W. J. HOBSON  
Chief Executive

## Form 2.1

*Town and Country Planning Act 1961*  
SHIRE OF TAMBO (BALANCE OF SHIRE)

Notice that an Interim Development Order Amendment has been Prepared and is Available for Inspection

Planning Scheme Interim Development Order  
1985

## Amendment No. 22

Notice is hereby given that the Shire of Tambo in pursuance of its powers under the *Town and*

*Country Planning Act 1961*, has prepared an Interim Development Order Amendment for the following:

That area situated on the immediate north-western corner of the subject land being Part Crown Allotment 11 section A Parish of Tambo, Omeo Highway, Bruthen and located on the east side of the Highway commencing approximately 900 metres north of Hosies Road for a site specific amendment to clause 7 of the ordinance to allow an excision for allotments to be created for the three (3) weatherboard dwellings.

A copy of the Order has been deposited at the Shire Offices, Main Street, Bruthen, and at the office of the Ministry for Planning and Environment (Plan Inspection Section), Ground Floor, The Olderfleet Buildings, 477 Collins Street, Melbourne, and will be open for inspection during office hours by any person free of charge.

Any persons affected by the Order are required to set forth in writing any submissions they may wish to make addressed to the Chief Executive, Shire of Tambo, P.O. Box 10, Bruthen, 3885, by 2 September 1987 and state whether you wish to be heard in respect of your submission.

8053 W. J. HOBSON  
Chief Executive

Notice is hereby given that the Hastings Yacht Club Inc. has applied for a lease pursuant to section 134 of the *Land Act 1958* of an area of approximately 3770 square metres, being Allotment 22 section D Township of Hastings for a term of 21 years for the purpose of amusement and recreation.

7884 G. D. RAITT, Secretary

## SUNBURY WATER BOARD

Location of Sewers in Diggers Rest Area  
(Re-advertised)

Notice is hereby given that the above Authority intends to construct sewers and related works in the area known as Diggers Rest Township to serve properties situated in the whole or parts of the areas hereinafter described in the Sunbury Sewerage District.

Maps and plans showing the works to be constructed are open for inspection at the Board's office between the hours of 9.00 a.m. and 5.00 p.m., Monday to Friday.

The area referred to above comprises the area in Licence Road adjacent lot 296 and along the southern boundary of lot 296 Licence Road.

7771 JOHN M. KELLY, Secretary

Sixth Schedule  
MORNINGTON PENINSULA AND  
DISTRICT WATER BOARD

General Notice

Declaration of Sewerage Area

The abovementioned Board having made provision for carrying off the sewerage from each and every property which, or any part of which, is within the Sewerage Area hereinafter described, doth hereby declare that on or after 1 September 1987 each and every property which, or any part of which, is within the said Sewerage Area shall be deemed to be a seweraged property within the meaning of the *Sewerage Districts Act 1958*.

The boundaries of the Sewerage areas hereinafter referred to are:

CITY OF FRANKSTON SEWERAGE  
DISTRICT

*Sewerage Area No. 362*

The boundaries of all that piece of land comprising Lot Nos. 66, 67, 71 to 100 inclusive on Lodged Plan of Subdivision No. 205360 such allotments having an abuttal to Settlers Way, Frankston.

*Sewerage Area No. 363*

The boundaries of all that piece of land comprising Lot Nos. 114 to 124 inclusive, 100, 220, 221, 107 to 110 inclusive on Lodged Plan of Subdivision No. 203210 such allotments having an abuttal to Aquarius Street, Frankston, Lot Nos. 101 to 106 inclusive on Lodged Plan of Subdivision No. 203210 such allotments having an abuttal to Apollo Court, Frankston, Lot Nos. 111 to 113 inclusive, 212 to 219 inclusive, 222 to 234 inclusive on Lodged Plan of Subdivision No. 203210 such allotments having an abuttal to Schooner Bay Drive, Frankston.

*Sewerage Area No. 364*

The boundaries of all that piece of land comprising Lot Nos. 60, 61 on Lodged Plan of Subdivision No. 13210, Lot Nos. 1 to 5 inclusive, on Lodged Plan No. 13454, Consolidation Plan Nos. 151934 and 155636 such allotments having an abuttal to Wells Road, Seaford, Lot Nos. 58 to 69 inclusive on Lodged Plan of Subdivision No. 13454 such allotments having an abuttal to Wedge Court, Seaford, Lot Nos. 12 to 15 inclusive on Lodged Plan of Subdivision No. 13454, Consolidation Plan No. 155711 such allotments having an abuttal to Armstrongs Road, Seaford.

*Sewerage Area No. 365*

The boundaries of all that piece of land comprising Lot Nos. 251 to 255 inclusive Part 249, Part 250 on Lodged Plan of Subdivision No.

10717 such allotments having an abuttal to Francis Street, Seaford, Lot Nos. Part 276, Part 277 on Lodged Plan of Subdivision No. 10717, Lot Nos. 91 to 93 inclusive, 95, 96, 117 to 119 inclusive, 132 to 134 inclusive on Lodged Plan of Subdivision No. 12131 such allotments having an abuttal to Wells Road, Seaford, Lot Nos. 278 to 280 on Lodged Plan of Subdivision No. 11717 such allotments having an abuttal to Greaves Street, Seaford, Lot Nos. 88 to 90 inclusive, 94, 97 to 100 inclusive on Lodged Plan of Subdivision No. 12131 such allotments having an abuttal to Rossiter Court, Seaford, Lot Nos. 112 to 116 inclusive, 127 to 131 inclusive on Lodged Plan of Subdivision No. 12131 such allotments having an abuttal to Bennett Court, Seaford.

*Sewerage Area No. 366*

The boundaries of all that piece of land comprising Lot No. 1 on Lodged Plan of Subdivision No. 8422, Lot Nos. 5 to 7 inclusive, 30 to 47 inclusive, 94 to 96 inclusive on Lodged Plan of Subdivision No. 13689 such allotments having an abuttal to Baxter-Tooradin Road, Baxter, Lot Nos. 48 to 51 inclusive, 81, 97 to 104 inclusive, 115 on Lodged Plan of Subdivision No. 13689 such allotments having an abuttal to St Kilda Street, Baxter, Lot Nos. 52 to 68 inclusive, 70, 82 to 93 inclusive, 105 to 114 inclusive, 130 to 140 inclusive on Lodged Plan of Subdivision No. 13689 such allotments having an abuttal to Toorak Avenue, Baxter, Lot Nos. 129, 141 to 147 inclusive on Lodged Plan of Subdivision No. 13689 such allotments having an abuttal to Grandview Grove, Baxter, Lot Nos. 8 to 11 inclusive, 69, 71 to 80 inclusive, 116 to 128 inclusive, 148, 149, such allotments having an abuttal to Golf Links Road, Baxter.

SHIRE OF FLINDERS SEWERAGE  
DISTRICT

*Sewerage Area No. 117*

The boundaries of all that piece of land comprising Lot Nos. 76, 77 on Lodged Plan of Subdivision No. 44936 such allotments having an abuttal to Waterfall Gully Road, Rosebud, Lot Nos. 78 to 82 inclusive on Lodged Plan of Subdivision No. 44936 such allotments having an abuttal to Caroline Court, Rosebud, Lot Nos. 83 to 89 inclusive, on Lodged Plan of Subdivision No. 44936, Lot Nos. 104, 109 to 112 inclusive on Lodged Plan of Subdivision No. 50763 such allotments having an abuttal to Anne Street, Rosebud, Lot Nos. 105 to 108 inclusive on Lodged Plan of Subdivision No. 50763 such allotments having an abuttal to York Street, Rosebud.

*Sewerage Area No. 118*

The boundaries of all that piece of land comprising Lot Nos. 219, 23 on Lodged Plan of Subdivision No. 147140, Lot Nos. 2 to 6 inclusive on Lodged Plan of Subdivision No. 119852, Lot Nos. 218, 14 on Lodged Plan of Subdivision No. 14741, RP 18354, Lot Nos. 9 to 11 inclusive on Lodged Plan of Subdivision No. 119852, Consolidation Plan No. 155274 such allotments having an abuttal to Colchester Road, Rosebud.

*Sewerage Area No. 119*

The boundaries of all that piece of land comprising Lot Nos. 1 to 4 inclusive, 9 to 19 inclusive on Lodged Plan of Subdivision No. 205458 such allotments having an abuttal to Newington Avenue, Rosebud. Lot Nos. 5 to 8 inclusive on Lodged Plan of Subdivision No. 205458 such allotments having an abuttal to David Court, Rosebud.

## SHIRE OF CRANBOURNE SEWERAGE DISTRICT

*Sewerage Area No. 148*

The boundaries of all that piece of land comprising Lot No. 1 on Lodged Plan of Subdivision No. 203991, Lot Nos. 1 and 2 on Lodged Plan of Subdivision No. 203992 such allotments having an abuttal to Cranbourne-Frankston Road, Cranbourne.

*Sewerage Area No. 149*

The boundaries of all that piece of land comprising Lot Nos. 1195 to 1197 inclusive on Lodged Plan of Subdivision No. 204677 such allotments having an abuttal to Currawong Drive, Carrum Downs, Lot Nos. 1177 to 1194 inclusive on Lodged Plan of Subdivision No. 204677 such allotments having an abuttal to Peregrine Place, Carrum Downs.

*Sewerage Area No. 150*

The boundaries of all that piece of land comprising Lot Nos. 1 to 12 inclusive on Lodged Plan of Subdivision No. 206135, such allotments having an abuttal to Pellita Way, Langwarrin.

*Sewerage Area No. 151*

The boundaries of all that piece of land comprising Lot Nos. 90 to 104 inclusive on Lodged Plan of Subdivision No. 206634, such allotments having an abuttal to Ferneroft Court, Cranbourne North, Lot Nos. 88, 89, 105 to 111 inclusive on Lodged Plan of Subdivision No. 206634, Lot Nos. 61, 74 to 84 inclusive, 86, 87 on Lodged Plan of Subdivision No. 206635 such allotments having an abuttal to Courtenay Avenue, Cranbourne North, Lot Nos. 62 to 73 inclusive on Lodged Plan of Subdivision No. 206635 such allotments having an abuttal to Jasmine Court, Cranbourne North, Lot No. 38

on Lodged Plan of Subdivision No. 206634 such allotment having an abuttal to Elizabeth Street, Cranbourne North.

*Sewerage Area No. 152*

The boundaries of all that piece of land comprising Lot Nos. 1 to 13 inclusive on Lodged Plan of Subdivision No. 68746, Lot Nos. 525 to 529 inclusive on Lodged Plan of Subdivision No. 2064, Lot Nos. 222, 489, 491 on Lodged Plan of Subdivision No. 1740 such allotments having an abuttal to Pearcedale Road, Pearcedale, Lot Nos. 516 to 520 inclusive on Lodged Plan of Subdivision No. 2064, Lot Nos. 59 to 64 inclusive on Lodged Plan of Subdivision No. 202259 such allotments having an abuttal to Cherry Street, Pearcedale, Lot Nos. 65 to 68 inclusive on Lodged Plan of Subdivision No. 202259 such allotments having an abuttal to Victoria Road, Pearcedale, Lot Nos. 69 to 74 inclusive on Lodged Plan of Subdivision No. 202259 such allotments having an abuttal to Colley Street, Pearcedale.

By order of the said Water Board

J. K. BUCHANAN  
Chairperson

J. O. WILLIAMS  
Secretary

8018

## SUNBURY WATER BOARD

## Sewerage District

## General Notice

Sewerage Areas Nos. 33, 34, 35 and 36

The abovementioned Water Board having made provision for carrying off the sewage from each and every property which any part of which is within the sewerage areas hereinafter described doth hereby declare that on and after 1 July 1987 each and every property which or any part of which is within the said sewerage areas shall be deemed to be a seweraged property within the meaning of the *Sewerage Districts Act 1958*.

The general boundaries of the Sewerage Area No. 33 hereinbefore referred to are on the north, the rear of properties fronting Reservoir Road, to the west, Wilsons Lane and to the east the rear of properties fronting Atkinson Close and Blackman Close.

The general boundaries of the Sewerage Area No. 34 hereinbefore referred to are on the north Gap Road, on the east the rear of properties fronting Bower Court, on the west the rear of properties fronting Rover Street and on the south the rear of properties fronting Keith Avenue.

The general boundaries of the Sewerage Area No. 35 hereinbefore referred to are on the north the rear of properties fronting Kerri Court, on

the south, Kerri Court, and on the east the rear of properties fronting Stewarts Lane.

The general boundaries of the Sewerage Area No. 36 hereinbefore referred to are on the northeast Riddell Road, on the southeast the rear of properties fronting Woodstock Close and on the northwest the rear of properties fronting Strathearn Drive.

Maps and plans of Sewerage Areas Nos. 33, 34, 35 and 36 are available for inspection at the Board's offices, Macedon Street, Sunbury between the hours of 9.00 a.m. and 4.00 p.m. Monday to Friday.

By Order of the Sunbury Water Board

JOHN J. McMAHON  
Chairman

JOHN M. KELLY  
Secretary

8056

Troon Street From Austin Avenue to Sunningdale Road.

Fourth Avenue Rosebud  
From Eastbourne Road to a point opposite Lot 98 about 124 metres northerly.

Fifth Avenue From Eastbourne Road to a point opposite Lots 77 and 78 about 237 metres northerly.

Booran Parade Tootgarook  
From Belar Road to a point opposite Lots 186 and 221 about 296 metres easterly.

Elizabeth Road Portsea  
From end of existing main opposite Lots 1 and 29 to a point opposite Lots 4 and 29 about 100 metres south-easterly.

Bambra Court Rye  
Omar Street Full length.  
From end of existing main opposite Lots 2573 and 2603 to a point opposite Lot 2605, about 39 metres northerly.

Howell Street From Browns Road to Menzies Street.  
Mernda Street From end of existing main opposite Lots 3612 and 3536 to Howell Street about 113 metres westerly.

Beryl Court Full length.  
Marcia Avenue From end of existing main opposite Lots 18 and 1 to Ocean Drive about 118 metres south-westerly.

Mulgra Street Frankston  
Jamesbrad Court Full Court Bowl.  
Baden Powell Drive Full length.  
From end of existing main opposite part Lot 9 to a point opposite part Lot 14 about 87 metres southerly.

*Water Act 1958*  
MORNINGTON PENINSULA AND  
DISTRICT WATER BOARD

Mornington Peninsula Urban District

Notice to owners of tenements in the undermentioned streets in the Mornington Peninsula Urban District and the private streets, lanes, courts and alleys opening thereto:

<i>Street</i>	<i>Section</i>
	<b>Safety Beach</b>
Tonkin Street	From Seaview Avenue to Rymer Road.
Anthony Street	From end of existing main opposite Lot 73 to Rymer Road about 643 metres easterly.
Picking Road	From end of existing main opposite Lot 25 to Rymer Road about 360 metres easterly.
Rymer Road	From Picking Road to Tonkin Street.
	<b>Dromana</b>
Weymouth Drive	From end of existing main opposite Lot 107 to a point opposite Lot 106 about 31 metres southerly.
	<b>McCrae</b>
Austin Avenue	From end of existing main opposite Lots 146 and 232 to Troon Street about 121 metres easterly.

	Seaford	Andrew Place	Full length.
Erwin Drive	From Government Road to a point opposite Lots 174 and 175 about 143 metres south-easterly.	Jeremy Court	Full length.
Anthony Court	Full length.	Dorothy Crescent	from Nichols Drive to a point opposite Lots 390 and 441 about 51 metres westerly.
Hunts Drive	From Erwin Drive to a point opposite Lots 147 and 174 about 25 metres north-easterly.		
		Carrum Downs	
		Greenwood Drive	From end of existing main opposite Lot 258 to a point opposite Lot 300 about 171 metres northerly.
	Mt Eliza	Heatherleigh Court	Full length.
Common Property off Gillards Road, (Private Driveway)	Full length to serve Lots 1 & 2.	Idonia Court	Full length.
Merrigal Court	Full length.		
Wynnstay Road	From end of existing main opposite Lots 14 and 23 to Wooralla Drive about 115 metres north-westerly.	Bergman Road	From end of existing main opposite Lot 1 to a point opposite Lot 4 about 66 metres northerly.
Claremont Street	From Victory Place to a point opposite lots 723 and 731 about 292 metres north-easterly.	Beacon Drive	From end of existing main opposite Lots 45 and 48 to Granite Drive about 162 metres northerly.
Quinton Court	Full length.	Granite Drive	Form a point opposite Lots 76 and 199 to a point approximately 67 metres east of Beacon Drive.
	Mornington	Rogan Court	Full length.
Dunns Road	From Craigie Road to a point opposite Lot 1 about 318 metres northerly. Western side only.	Raewyn Court	Full length.
Francis Drive	From Dunns Road to a point opposite Lots 14 and 54, about 200 metres westerly.		
Tanya-Lee Court	Full length.	Wallaroo Place	From Tambar Place to a point opposite Lot 11, about 43 metres southerly.
Lisa-Britt Court	Full length.	Davies Street	From Wooleys Road to a point opposite Lots 56 and 60 about 487 metres southerly.
Grantdee Court	Full length.		
Nichols Drive	From Moomba Street to a point opposite Lots 442 and 446 about 249 metres southerly.		
Moomba Street	From Nichols Drive to link up with existing main at a point opposite Pt. 13, about 309 metres westerly.	Randor Rise	
		Evans Street	
Moomba Street	From Brent Street to link up with existing main at a point opposite Lot 42 about 72 metres westerly.	Peryman Street	
			Somerville
			Full length.
			Pearcedale
			From Colley Street to Peryman Street.
			from end of existing main opposite Lot 162 to Evans Street, about 221 metres northerly.



	<b>Crib Point</b>
Lorimar Street	From end of existing main opposite Lots 188 and 8 to Verdun Street about 47 metres easterly.
Verdun Street	From Lorimar Street to Disney Street.
	<b>Balnarring</b>
Fethers Road	From end of existing main opposite Lot 2 to a point opposite Lot 3 about 20 metres easterly.
	<b>Pakenham</b>
Tania Court	Full length.
Barbara Court	Full length.
Healesville-Kooweerup Road	From end to existing main opposite Lot 2 to a point opposite Lot 9 about 127 metres north-easterly.
	<b>Buninyip</b>
Wattle Tree Road	From end of existing main opposite Lots 1 and 35 to a point opposite Lots 2 and 35 about 15 metres easterly
	<b>Garfield</b>
Barker Road	From Garfield North Road to a point opposite Lots 8 and 19 about 481 metres westerly.
	<b>Blind Bight</b>
Channel Crescent	From Fishermans Drive to a point opposite Lots 278 and 259 about 100 metres westerly.
Gannet Close	Full length.
	<b>Kooweerup</b>
Charles Street	From end of existing main opposite Lots 1 and 10 to a point opposite Lot 2, about 21 metres southerly.

The main pipe in the said streets being laid down, the owners of all tenements situated as above are hereby required, on or before 1 September 1987 to cause proper pipes and stop cocks to be laid so as to supply water within such tenements from the main pipe.

Dated at Frankston, 22 July 1987

J. O. WILLIAMS, Secretary  
Mornington Peninsula and  
District Water Board

8019

**STAWELL WATER BOARD**

**Notice of Commencement of Construction of Sewerage Works**

Pursuant to section 119 (2) of the *Sewerage Districts Act 1958* notice is hereby given of the intention to construct sewers for properties situated in the following areas, at least 30 days after the date of this notice:

Haughton Street, Crown allotment 30, section 255, Parish of Stawell, and more particularly as shown on plans which are open for inspection at the office of the Stawell Water Board between the hours of 8.30 a.m. and 5.15 p.m., Monday to Friday, inclusive.

N. R. ILLIG  
Secretary

8017

**BALLARAT WATER BOARD**

Pursuant to section 119 (2) of the *Sewerage Districts Act 1958* (No. 6368) notice is hereby given of the intention to construct sewers for properties situated generally in the following areas:

**Shire of Buninyong**

Buninyong Sewerage Reticulation Stage 3A, Yuille Street between Warrenheip and Fiskens Streets, Simpson Street between Cornish and Lal Lal Streets and Cornish and Fiskens Streets between Herriot and Yuille Streets.

**Ballarat North**

North of Norman Street between Simpson Street and Doodts Road, more particularly as shown on plans which are open for inspection at this office between the hours of 8.45 a.m. and 4.30 p.m., Monday to Friday, inclusive.

P. A. POLLARD  
Secretary

8020

**FAR EAST GIPPSLAND ABORIGINAL CORPORATION**

Notice is hereby given that the Far East Gippsland Aboriginal Corporation has applied for a lease under section 134 of the *Land Act 1958* for a term of 99 years in respect of 7.156 hectares of Crown Land facing the Cann Valley Highway at Cann River; being allotment 13, section 9, Township of Cann River; for commercial purposes.

A. MONGTA  
Secretary

8064

*Wheat Marketing Act 1984 of Victoria*  
**DELIVERY OF WHEAT TO AUSTRALIAN  
 WHEAT BOARD**

To all persons in Victoria

Take Notice that pursuant to sub-section 8 (2) of the *Wheat Marketing Act 1984* you are required to deliver to the Australian Wheat Board within seven days from the date of the Notice (hereinafter referred to as "the Board") all wheat that is in your possession on the date on which this Notice is published in the Gazette and all wheat coming into your possession after that date but before 1 July 1988, other than—

- (a) wheat retained on the farm on which it was grown (hereinafter referred to as "the farm of production") for use on that farm;
  - (b) wheat which pursuant to a permit issued by the Board is moved from the farm of production—
    - (i) to a mill for gristing with the object of returning the products of gristing to the farm of production for use on that farm;
    - (ii) to another farm approved by the Board for use on that other farm; or
    - (iii) to another farm for feeding to agisted stock owned by the owner of the farm of production;
  - (c) wheat which the Board declares to be—
    - (i) seed wheat; or
    - (ii) inferior wheat;
- to which this Act does not apply;
- (d) wheat which pursuant to a permit issued by the Board is purchased for a stockfeed use;
  - (e) wheat that has been sold by the Board;

Also take notice that pursuant to sub-section 8 (4) of the *Wheat Marketing Act 1984* any person—

- (a) who without reasonable excuse refuses or fails to deliver wheat to the Board in accordance with this notice; or
- (b) who delivers to the Board wheat which has been previously sold by the Board, commits an offence punishable in the case of an individual by a fine of 100 penalty units and in the case of a body corporate by a fine of 500 penalty units.

Wheat may be delivered to the Board by delivering the wheat to any of the Board's authorised receivers. A penalty unit currently has a value of \$100.

For information as to the names and addresses of the authorised receivers or any other matter in relation to this notice please contact—

The State Manager, Australian Wheat Board,  
 14th Floor, Marland House, 570 Bourke Street,  
 Melbourne. Vic. 3000 Telephone: (03) 67 6261  
 Dated at Melbourne 10 July 1987.

The common seal of the Australian Wheat Board was hereunto affixed in the presence of—

CLINTON CONDON  
 Chairman

D. T. NORTON  
 Secretary

8065

**NOTICE OF DISSOLUTION OF  
 PARTNERSHIP**

Kim Christine McKay and John Wayne West who previously traded in partnership as A-Z Printers & Stationers give notice that the partnership was dissolved with effect from 31 May 1986.

John Wayne West is continuing to trade as A-Z Printers & Stationers. Kim Christine McKay has no further interest in that business.

ANTHONY J. BONE, solicitor, 696 High Street, East Kew 8021

**NOTICE OF DISSOLUTION OF  
 PARTNERSHIP**

Notice is hereby given that the partnership heretofore subsisting between the undersigned medical practitioners at 71 Victoria Parade, Fitzroy has been dissolved by mutual consent as from 3 July 1987.

Gary Patrick Sherman will continue to practise on his own account from 71 Victoria Parade, Fitzroy. John Timothy Kennedy will continue to practise on his own account from 19 Simpson Street, East Melbourne.

Dated 3 July 1987.

JOHN TIMOTHY KENNEDY  
 GARY PATRICK SHERMAN

Corrs Pavey Whiting & Byrne, solicitors, 350 William Street, Melbourne 8022

**NOTICE OF DISSOLUTION OF  
 PARTNERSHIP**

Notice is hereby given that the partnership heretofore subsisting between Michael Richard Webb and Jaclyn Sylvia Webb carrying on the business of Registered Valuer and Licensed Estate Agent under the name of Michael R. Webb from premises at 53 Little Rynie Street, Geelong has been dissolved as and from 30 June 1987. The business will continue to be carried on by Michael Richard Webb.

ANDREWS & BACKHOUSE, solicitors, of 115 Myers Street, Geelong 7973

Take Notice that the partnership of Margolis Tuszynski Klein & Schwarcz, solicitors of 133 and 137 Hawthorn Road, Caulfield was dissolved on 30 June 1987 and that Messrs Morris Margolis, Ian Tuszynski and Ronald Klein will continue to practice, in partnership, at 133 Hawthorn Road, Caulfield under the firm name Margolis Tuszynski & Klein. Mr. Tibor Schwarcz will continue to practice at 137 Hawthorn Road, Caulfield 8023

As from 1 August 1987, Edwin Kennon has resigned from the partnership of Stedman, Cameron, Meares & Hall. The firm will continue under the name of Stedman Cameron and the phone number is now 670 7211. 8085

In the Supreme Court of Victoria—1987 No. Co423—in the matter of the Companies (Victoria) Code; and in the matter of Adhara Investments Pty. Ltd.—Advertisement of Application for Winding Up

Notice is hereby given that an application for the winding up of the abovenamed company by the Supreme Court of Victoria was on 30 June 1987 filed by Frankston Ambassador Pty. Ltd. The application is to be heard before the Court in 7th Court, Law Courts, Lonsdale Street, Melbourne at 10.30 a.m. on 19 August 1987.

The Liquidator whose appointment is sought is John David Adams of the firm of Parkhill Lithgow & Gibson of 500 Collins Street, Melbourne.

Any creditor or contributory of the company desiring to support or oppose the making of an order on the application may appear at the time of hearing by himself or his Counsel for that purpose. A copy of the application will be furnished by the undersigned to any creditor or contributory of the company requiring it on payment of the regulated charge.

The applicant's address is 325-331 Nepean Highway, Frankston.

The applicant's solicitor is Henderson & Ball of 722 High Street, East Kew.

Note: Any person who intends to appear on the hearing of the application must serve on or send by post to the abovenamed solicitor notice in writing of his intention to do so. The notice must state the name and address of the person or, if a firm, the name and address of the firm and must be signed by the person or firm or his or their solicitor (if any) and must be served or, if posted, must be sent by post in sufficient time to be received not later than 4 o'clock in the afternoon of 18 August 1987. 8024

In the Supreme Court of Victoria—1987 No. Co422—in the matter of the Companies (Victoria) Code; and in the matter of Thomas Standing Real Estate Pty. Ltd.—Advertisement of Application for Winding Up

Notice is hereby given that an application for the winding up of the abovenamed company by the Supreme Court of Victoria was on 30 June 1987 filed by Fenton Lane Pty. Ltd. The application is to be heard before the Court in 7th Court, Law Courts, Lonsdale Street, Melbourne at 10.30 a.m. on 19 August 1987.

The Liquidator whose appointment is sought is John David Adams of the firm of Parkhill Lithgow & Gibson of 500 Collins Street, Melbourne.

Any creditor or contributory of the company desiring to support or oppose the making of an order on the application may appear at the time of hearing by himself or his Counsel for that purpose. A copy of the application will be furnished by the undersigned to any creditor or contributory of the company requiring it on payment of the regulated charge.

The applicant's address is 415 Toorak Road, Toorak.

The applicant's solicitor is Henderson & Ball of 722 High Street, East Kew.

Note: Any person who intends to appear on the hearing of the application must serve on or send by post to the abovenamed solicitor notice in writing of his intention to do so. The notice must state the name and address of the person or, if a firm, the name and address of the firm and must be signed by the person or firm or his or their solicitor (if any) and must be served or, if posted, must be sent by post in sufficient time to be received not later than 4 o'clock in the afternoon of 18 August 1987. 8025

**A. M. O'HALLORAN PROPRIETARY LIMITED**

(in Voluntary Liquidation)

Special Resolution to Wind Up

At an extraordinary general meeting of the abovenamed company duly convened and held at 4 Brodie Street, Bendigo on 15 July 1987, the following resolution was passed as a special resolution:

That the company be wound up voluntarily.

At the abovementioned meeting F. E. Douglass was appointed liquidator for the purpose of the winding up.

Dated 10 July 1987

8030 F. E. DOUGLASS, Liquidator

Pursuant to the *Trustee Act 1958*, notice is hereby given that all persons having claims against the estate of William Thomas Edmund Whitehead, late of Unit 5, 14-16 Surrey Road, Croydon, gentleman, deceased, who died on 17 August 1986, and letters of administration with the will annexed the executors having renounced Probate was granted by the Supreme Court of the State of Victoria in its Probate Jurisdiction on 6 July 1987 to Coral Jean Whitehead of Unit 5, 14-16 Surrey Road, Croydon, widow, are hereby required to send particulars in writing of such claims to the said Coral Jean Whitehead at her abovementioned address on or before 29 September 1987, after which date the said Coral Jean Whitehead is to distribute the assets of the said William Thomas Edmund Whitehead, deceased, which shall have come to her hands amongst the persons entitled thereto having regard only to the claims of which she shall then have had notice. Notice is hereby further given that the said Coral Jean Whitehead will not be liable for the assets so distributed or any part thereof to any person of whose claim she shall not have had notice as aforesaid.

Dated 20 July 1987

**PATRICK HARTL & ASSOCIATES,**  
solicitors, 60 Main Street, Croydon, proctor for  
the said Coral Jean Whitehead 8031

Notice is hereby given that a general meeting of members of D.J.F. Homes Pty. Ltd. will be held at 11.00 a.m. on 28 August 1987, at the office of Crosbie, Doran & Co., Public Accountants, 1st Floor, 266 Hampshire Road, Sunshine. The purpose of the meeting is to place before the members the liquidator's final accounts and give an explanation of them.

**BRIAN NORMAN HOSKIN**  
8026 A.A.S.A. Liquidator

In the Supreme Court of Victoria—1987  
Company No. C—201185 R—In the matter  
of the Companies (Victoria) Code; and in the  
matter of R.V.P. Nominees Pty. Limited

Notice is hereby given that an application for the winding up of the abovenamed company by the Supreme Court of Victoria was on 2 July 1987, filed by Floorstock Pty. Ltd. The application is to be heard before the Court in the Seventh Court, Law Courts, Lonsdale Street, Melbourne at the hour of 10.30 o'clock in the forenoon on 2 September 1987. The liquidator whose appointment is sought is Robert Molesworth Hobill Cole of the firm of Robert M. H. Cole & Co., 499 Bourke Street, Melbourne, Victoria.

Any creditor or contributory of the company desiring to support or oppose the making of an order on the application may appear at the time of hearing by himself or his Counsel for that purpose. A copy of the application will be furnished by the undersigned to any creditor or contributory of the company requiring it on payment of the regulated charge.

The applicant's address is Floorstock Pty. Ltd. of corner of Linton and Horscroft Place, Moorabbin, Victoria.

The applicants solicitor is Ian Michael Tapley Timms, of 1st Floor, 63 High Street, Cranbourne.

**EAGLE & TIMMS,**  
solicitors for the applicant

Note—Any person who intends to appear on the hearing of the application must serve on or send by post to the abovenamed solicitors, notice in writing of his intention so to do. The Notice must state the name and address of the person, or if a firm, the name and address of the firm, and must be signed by the person or firm, or his or their Solicitors (if any), and must be served or, if posted, must be sent by post in sufficient time to be received not later than 4 p.m. on 1 September 1987. 8070

*Companies Act 1961, Section 272*

**CLANMERRA PTY. LTD. (In Liquidation)**  
Notice Convening Final Meeting of Members  
and Creditors

Notice is hereby given pursuant to section 272 of the *Companies Act 1961* that a General Meeting of the Members and Creditors of the abovenamed Company will be held at the offices of Ferrier Hodgson & Co., 24th Floor, 459 Collins Street, Melbourne, on Monday 31 August 1987 at 11.00 a.m. for the purpose of having an account laid before them showing the manner in which the winding up has been conducted and the property of the Company disposed of and of hearing any explanations that may be given by the Liquidator.

Dated 27 July 1987

**R. H. JUDSON**  
8081 Liquidator.

**COMPANIES (VICTORIA) CODE**

Notice is hereby given that the following special resolution passed at an extraordinary general meeting of Morresam Pty Ltd held on 24 July 1987:

That the company be voluntarily wound up in accordance with the Companies (Victoria) Code.

**NORMAN RAITMAN**  
8042 Liquidator

Companies Form 81  
Registered No C 75007 Z, Sub-section 326 (2)  
**NOTICE BY RECEIVER AND MANAGER  
CEASING TO ACT**

Natural Life Health & Vitamin Centres Ltd  
I, Ernest Harding Niemann, Receiver and  
Manager of the property of the company under  
the power contained in an instrument dated 25  
July 1979 being a Mortgage Debenture registered  
number 35302 give notice that I ceased to act as  
such, in respect of the property described in the  
Schedule on 10 July 1987.

**Schedule**

All and singular the undertaking and assets of  
the company whatsoever and wheresoever both  
present and future including its uncalled capital  
for the time being and the uncalled premiums  
for the time being on its shares or stock.

Dated 17 July 1987

8057

E. H. NIEMANN

**KEW MUFFLERS PTY. LTD.**

**Notice of Distribution**

Notice is hereby given that the company acting  
in its capacity as trustee of the Kew Mufflers  
Unit Trust has appointed a distribution date for  
the purposes of distributing all property of the  
Kew Mufflers Unit Trust.

The distribution date so appointed is 7  
September 1987 7876

**OAKMONT PTY. LIMITED**

**(In Voluntary Liquidation)**

**Special Resolution to wind up**

At an Extraordinary General Meeting of the  
abovenamed company duly convened and held  
at 377 Little Collins Street, Melbourne on 20  
July 1987, the following Resolution was passed  
as a Special Resolution:

"That the company be wound up voluntarily."

At the abovementioned meeting, K. A. Sharp  
was appointed Liquidator for the purpose of the  
winding up.

Notice is also given, that after 30 days from  
this date, I shall proceed to distribute the assets.  
All creditors having any claims against the  
company, should furnish particulars of same by  
that date, otherwise I shall proceed to distribute  
the assets without regard to their claims.

The final meeting of the company will be held  
on 25 August 1987 at 12 noon, at 377 Little  
Collins Street, Melbourne.

Dated 20 July 1987.

8071

K. A. SHARP  
Liquidator

**NOTICE OF RESOLUTION**

The Directors of Springhill Co-operative Ltd.  
hereby give notice of the following resolution  
passed at their meeting on 29 June 1987:

**Resolved:**

- (i) The co-operative be wound up voluntarily;
- (ii) The society's auditors, Gillards Pty. be  
appointed to wind up the co-operative and  
that they be paid on an hourly basis as  
follows: Principals \$80, senior accountants  
\$60 and clerical \$50.
- (iii) Upon winding up, after satisfaction of all  
debts and liabilities (including repayment  
of the paid-up capital) the remaining assets  
be paid or distributed amongst the  
members of the society in such equal parts  
for each one dollar share owned or  
equitably owned by such members;
- (iv) The society's books be destroyed after two  
years.

8027

R. EADE, Chairman  
W. PATTINSON, Secretary

Companies (Victoria) Code, Section 392 (2)  
**BELITA PTY. LTD. (IN LIQUIDATION)**  
(Trading as Madison's)

Notice is hereby given that at a general meeting  
of members of the abovenamed company held  
on 16 July 1987, it was resolved that the company  
be wound up voluntarily and that for such  
purpose Dean R. McVeigh and Tim A. Jonas,  
both chartered accountants, of KMG  
Hungerfords, 80 Collins Street, Melbourne be  
appointed joint and several liquidators.

Dated 16 July 1987

8028

D. R. McVEIGH, Liquidator

*Co-operative Housing Societies Act 1958*  
**HEIDELBERG DISTRICT (No. 5)  
COOPERATIVE HOUSING SOCIETY  
LIMITED**

Notice is hereby given that at a special general  
meeting of the abovenamed society duly  
convened and held at 126 Wellington Parade,  
East Melbourne, on Friday, 17 July 1987, at 12.30  
p.m. the following special resolution was duly  
passed:

That the society having successfully completed  
its objectives 84 months ahead of its expected  
term be wound up voluntarily, and that John  
Patrick Chaundy of 126 Wellington Parade, East  
Melbourne, be appointed liquidator for the  
purposes of the winding up.

Dated 21 July 1987

8029

R. A. LANGLEY, Chairman  
J. P. CHAUNDY, Secretary

**HESELEV AND ASSOCIATES PTY.  
LTD.**

**Notice of Distribution**

Notice is hereby given that the company acting in its capacity as trustee of the Rob Heselev Family Trust has appointed a distribution date for the purposes of distributing all property of the Rob Heselev Family Trust.

The distribution date so appointed is 7 September 1987. 7877

**MAXWELL HERBERT GERLACH**, late of Walker Street, Angelsea in the State of Victoria, gentleman

Creditors, next of kin and others having claims in respect of the estate of the deceased who died on 18 July 1986 are required by the Executors Keith Clifford and Mary Monica O'Callaghan both of 8/600 Lonsdale Street, Melbourne, solicitors and Alan Murray Horsburgh and John Martin Walsh both of 499 St. Kilda Road, Melbourne, chartered accountants to send particulars of their claims to the said Executors care of Oakley, Thompson & Co of 8/600 Lonsdale Street, Melbourne solicitors by 16 October 1987 after which date the Executors may convey or distribute the assets having regard only to the claims of which they then have notice.

**OAKLEY, THOMPSON & CO**, solicitors, 8/600 Lonsdale Street, Melbourne 3001 8076

**ROBERT LAMAC**, late of 1 Caroline Avenue, Cockatoo, in the State of Victoria, linesman, deceased

Creditors, next of kin and others having claims in respect of the estate of the deceased are required to send particulars of their claims to the executor, Frank Lamac care of the undersigned solicitors by 28 September 1987, after which date the said executor will proceed to distribute the estate having regard only to the claims of which he then has notice.

**ARMSTRONG, SINGER & ROSS**, solicitors, 647A Main Street, Belgrave 8077

Creditors, next of kin and others having claims in respect of the Estate of Winifred Florence Henderson late of 3 Hazel Street, Belmont, widow, deceased who died on 7 June 1987, are required to send particulars of their claims to the Executrix Winifred Jean Reece care of the undersigned solicitors before 30 September 1987 after which date the assets of the estate will be distributed having regard only to the claims of which the Executrix then has notice.

**HARWOOD & PINCOTT**, solicitors, 77 Moorabool Street, Geelong 8078

Creditors, next of kin and others having claims against the estate of Lillian Mabel Pattison (also known as Lily Mabel Addison) late of 2 Princess Street, Oakleigh, widow who died on 3 May 1987 are required to send particulars of their claims to Lawrence Vernon Charles Anderson, the Executor to whom Probate of the Will has been granted by the Supreme Court, C/- Messrs. Campbell & Shaw, Solicitors, 30 Chester Street, Oakleigh by 4 September 1987 after which date he will then commence to distribute the assets having regard only to the claims of which he then has notice.

**CAMPBELL & SHAW**, solicitors, 30 Chester Street, Oakleigh 3166 8041

**THOMAS HOWARD ROBISON** late of Goorang Street, Katamatite, retired farmer, deceased

Creditors, next of kin and others having claims in respect of the estate of the deceased who died on 12 March 1987 are required by the Perpetual Executors and Trustees Association of Australia Limited of 50 Queen Street, Melbourne, to send particulars of their claims to the Company by 30 September 1987 after which date it will convey or distribute the assets, having regard only to the claims of which the Company then has notice.

**MADDEN BUTLER ELDER & GRAHAM**, solicitors of 575 Bourke Street, Melbourne 8043

Creditors, next of kin and others having claims in respect of the estate of Eileen Mary Hart late of 159 Ross Street, Port Melbourne, retired deceased who died on 2 May 1987 are requested to send particulars of their claims to the executor, Ronald Milton Douglas care of the undermentioned solicitors on or before 30 September 1987 after which date he will distribute the assets having regard only to the claims of which he then has notice.

**McKEAN & PARK**, 405 Little Bourke Street, Melbourne 8044

Creditors, next of kin and others having claims in respect of the estate of Ethel Violet Webster late of Flat 4, 17 Muir Street Hawthorn in the State of Victoria, widow deceased who died on 1 March 1987 are required by the executor the Equity Trustees Executors and Agency Company Limited of 472 Bourke Street, Melbourne in the said State to send particulars of their claims to the said company by 30 September 1987 after which date the said executor will convey or distribute the assets having regard only to the claims of which the said executor then has notice.

**DARVALL McCUTCHEON**, solicitors of 80 Collins Street, Melbourne 8045

Creditors, next of kin and others having claims in respect of the Estate of Stefan Angelov Mollov late of 202 Separation Street, North Geelong, pot room worker, deceased who died on 6 November 1986 are required to send particulars of their claims to the Executors Boris Valchev Stoeff and Mary Boris Stoeff care of the undersigned solicitors before 28 September 1987 after which date the assets of the Estate will be distributed having regard only to the claims of which the Executors then have notice.

**HARWOOD & PINCOTT**, solicitors, 77 Moorabool Street, Geelong 8079

Creditors, next of kin and other persons having claims in respect of the Estate of Kathleen Mary Garrard late of 10 Mernda Avenue, Carrum in the State of Victoria, married woman, deceased intestate who died on 28 March 1978 are required by Cheryl Ann Motttram of 7 Darren Road, Springvale South in the said State married woman (the Legal Personal Representative of William Alexander Garrard the husband of the said deceased he having survived the deceased but died without obtaining a Grant), to send particulars of their claims to her care of the undersigned by 26 September 1987 after which date she will convey or distribute the assets of the estate having regard only to the claims of which she then has notice.

**MINTER ELLISON**, solicitors, 379 Collins Street, Melbourne 8082

Creditors, next of kin or others having claims in respect of the estate of Muriel Myrtle Millsom late of Lot 3 Coonoc Road, Traralgon, home duties, deceased who died on 20 June 1987 are to send particulars of their claims to the executors care of the undermentioned solicitors by 27 September 1987 after date the executors will distribute the assets having regard only to the claims of which they then have notice.

**D. C. DAVINE EDMUNDS & CO.**, solicitors, 39 Breed Street, Traralgon 3844 8034

Creditors, next of kin and others having claims in respect of the Estate of Thomas McKean late of 17 Buckley Street Yarrum pensioner deceased who died on 9 October 1986 are required by the executor Allen Maxwell McKean of 66 Darvall Street, Donvale, Bank Manager to send particulars of their claim care of the undermentioned solicitor by 21 October 1987 after which date the said executor will distribute the assets of the deceased having regard only to the claims of which he then shall have notice.

**B. J. WILLIAMS LL.B.**, solicitor, 106 Lower Plenty Road, Rosanna 8032

Creditors, next of kin and others having claims in respect of the Estate of John Harwood Collier late of Unit 4, 35 Rose Street, Altona, clerk, deceased who died intestate on 24 January 1987 are required by the Administrator Russell Peter Cocks of 80 Stephen Street, Yarraville, solicitor to send particulars to him of their claims to his solicitors on or before 30 September 1987 after which date he will convey or distribute the assets having regard only to the claims of which he shall then have had notice.

**SECOMB McDONALD SMITH JONES & KENNEDY**, solicitors, 339 William Street, Melbourne West 8033

**ROBERT JOHN USHER** (deceased), late of "Ando", Ando, N.S.W., died on 12 February 1987

Any persons claiming to be dependent upon the deceased are requested to send particulars of their claims to Life Claims Department, Australian Eagle Ins. Co. Ltd, G.P.O. Box 1883R, Melbourne 3001, within two months of the date of this notice, after which date the deceased's entitlement will be distributed in accordance with the provisions of the Eagle Retirement Fund Trust Deed, having regard only to the claims which have been notified. 8059

**ALYSIA MARGARET DORGAN**, late of 79 Widford Street, Glenroy, Victoria, widow, deceased

Creditors, next of kin and others having claims in respect of the estate of the abovenamed deceased (who died on 20 January 1987), are required to send particulars of their claims to the executor, Wayne Francis Dorgan of 36 Cromwell Street, Glenroy in the State of Victoria, care of the undermentioned solicitors by 7 October 1987, after which date he may convey or distribute the assets having regard only to the claims of which he then has notice.

**AITKEN, WALKER & STRACHAN**, solicitors, 114 William Street, Melbourne 8060

**ROBERT HENRY DUNCAN**, late of "Selby Court", Olinda, retired farmer, deceased

Creditors, next of kin and others having claims in respect of the estate of the deceased, who died on 29 December 1986, are required by the trustees, Geoffrey Arthur Duncan and Judith Ann Symons to send particulars of their claims to them care of the undersigned solicitors by 14 September 1987, after which date the trustees may convey or distribute the assets having regard only to the claims of which they then have notice.

**GRAY, FRIEND & LONG**, solicitors, Warragul 8061

WINIFRED ANNIE BLACKWELL, late of 33 Stokes Street, Queenscliff in the State of Victoria, married woman, deceased

Creditors, next of kin and others having claims in respect of the estate of the abovenamed deceased, who died on 10 January 1987 are required by the administrator, Ian Priddle of 24 Carina Road, Turramurra in the State of New South Wales, gentleman, to send particulars of their claims to the administrator, care of the undermentioned solicitors by 20 September 1987, after which date the administrator may convey or distribute the assets having regard only to the claims of which he then has notice.

INGPEN & BENT, solicitors, 95 Yarra Street, Geelong 8062

HERBERT PAUL BREUER, late of Lutheran Rest Home, Trinity Drive, Horsham, retired orchardist, deceased

Creditors, next of kin and others having claims against the estate of the deceased, who died 27 April 1987 are required to send particulars of their claims to the executors, Coral L. Hookham and Garry M. Breuer, care of the address below, by 31 September 1987, after which date the executors shall distribute the assets having regard only to the claims of which they then have notice.

G. M. BREUER, 18 Myrtle Grove, Blackburn 8063

SHEILA MARGET PIESSE (deceased), late of "KooBADONG", Wagin, W.A., died on 6 December 1985

Any persons claiming to be dependent upon the deceased are requested to send particulars of their claims to "Life Claims Department, Australian Eagle Ins. Co. Ltd., G.P.O. Box 1883R, Melbourne 3001" within two months of the date of this notice after which date the deceased's entitlement will be distributed in accordance with the provisions of the Eagle Retirement Fund Trust Deed, having regard only to the claims which have been notified.

7904

EVELYN ANNIE WILSON, late of 64 Freeburgh Avenue, Mount Beauty in the State of Victoria, widow formerly married woman, deceased

Creditors, next of kin and others having claims in respect of the deceased (who died on 14 May 1987) are required to send particulars of their claims to Thomas Joseph Wilson and William Richard Wilson care of Walsh, Johnston & Co., solicitors of 452 High Street, Northcote before 7 October 1987 after which date they may convey or distribute the assets having regard only to the claims of which they then have notice.

8072

Creditors, next of kin and others having claims in respect of the estate of Doris Mavis Dickson, late of 7 Vaynor Street, Niddrie, in the State of Victoria, widow, deceased, who died on 30 May 1987 are required by the executors, Robert James Dickson, aircraft maintenance engineer, of 50 Clovelly Avenue, Glenroy and Christopher Robin Dickson, draftsman, of 7 Goa Court, Keilor East in the said State to send particulars of their claims to the said executors care of the undermentioned solicitors by 30 September 1987 after which date the said executors will convey or distribute the assets of the deceased having regard only to the claims of which the said executors then have notice.

MESSRS. MAKARUCHA & DE MARCO, solicitors, of 250 Glenroy Road, Glenroy 8035

Creditors, next of kin and others having claims against the estate of Tom Grouios (also known as Athanassios Grouios) late of 19 Mayfield Grove, Laverton, retired, deceased (who died on 12 January 1987) are required by Peter Grouios the executor of the will of the said deceased to send to him care of the undersigned solicitors particulars thereof by 30 September 1987 after which date he distribute the assets of the deceased having regard only to the claims of which he shall then have notice.

GAVAN DUFFY & KING, solicitors, 95 Queen Street, Melbourne 8036

ARCANGELA CIAVARELLA, late of 33 Winn Grove, Fawkner, widow, deceased

Creditors, next of kin and others having claims in respect of the estate of the abovenamed deceased who died on 11 February 1987 are to send particulars of their claims to the executor Michele Ciavarella care of the undermentioned solicitors by 30 September 1987 after which date the said executor will distribute the assets of the deceased having regard only to the claims of which he then has notice.

O'BRIEN & GALANTE, solicitors, 27 Norwood Crescent, Moonee Ponds 8037

ERNEST EDWARD HONIG, late of 45 Gladstone Avenue, Croxton in the State of Victoria, retired carpenter, deceased

Creditors, next of kin and others having claims in respect of the deceased (who died on 8 June 1987) are required to send particulars of their claims to Iris Daphne Honig and Michael Edward Honig care of Walsh, Johnston & Co., solicitors, of 452 High Street, Northcote before 7 October 1987 after which date they may convey or distribute the assets having regard only to the claims of which they then have notice.

8073



**FREDERICK JOHN SHEPPARD**, late of 28 Henry Street, Windsor, plumber, deceased

Creditors, next of kin and others having claims in respect of the estate of the deceased (who died on 26 March 1987 and who traded as Plumbing Service Company) are required by Richard Brooke Boothby and John Reilly Kyne both of 883 Dandenong Road, Caulfield East, solicitors, the executors of the will of the said deceased, to send particulars of their claims to the said executors by 5 October 1987 after which date the said Executors will convey or distribute the assets having regard only to the claims of which they then have notice.

**BOOTHBY & BOOTHBY**, solicitors, 883 Dandenong Road, Caulfield East 8046

Creditors, next of kin and others having claims in respect of the estate of Betty Agnes Hardy, late of 7 Birdwood Avenue, Dandenong, married woman, who died on 14 March 1987 are to send particulars of their claims to ANZ Executors & Trustee Company Limited of 94 Queen Street, Melbourne by 30 September 1987 after which date it will distribute the assets having regard only to the claims of which it then has notice.

8047

Creditors, next of kin and others having claims against the estate of Walter Dikstein late of 2, 109 Park Street, South Yarra, company director, deceased who died on 25 February 1987 and Probate of whose Will was granted by the Supreme Court of Victoria in its Probate Jurisdiction on 22 July 1987 are required to send particulars of their claims to the executors care of Minter Ellison of 379 Collins Street, Melbourne by 6 October 1987, after which date the executors will distribute the assets of the estate having regard only to the claims of which they then have notice.

8075

Creditors, next of kin and others having claims against the estate of Agnes Mary Walker, late of 43 Bridge Road, Beechworth in the State of Victoria, widow, deceased, who died on 17 May 1987 are required by the executors of the will of the said deceased James Leslie Kelly of 51 Salisbury Street, Benalla, gentleman and Eileen Veronica Rennie, of 43 Bridge Road, Beechworth aforesaid to send particulars of their claims to them care of the undermentioned solicitor by 7 October 1987 after which date the executors may convey or distribute the assets of the said deceased having regard only to the claims of which they then have notice.

**DENIS JOHNSTON**, solicitor, Cnr. Bridge & Nunn Streets, Benalla 8058

Creditors, next of kin and others having claims in respect to the estate of Norman Clifford Orr, late of 20 Bishop Street, Kingsville in the State of Victoria, deceased, intestate who died on 21 May 1987 are required to send particulars of their claims to the Administrator Frederick Orr care of the undermentioned solicitors by 30 September 1987 after which date the Administrator will distribute the assets of the deceased having regard only to the claims of which he then has had notice.

**SECOMB McDONALD SMITH JONES & KENNEDY**, solicitors, 59-63 Irving Street, Footscray 8048

Creditors, next of kin and others having claims against the estate of Margaret Elizabeth McIntosh late of 1 Delatite Avenue, Shepparton, widow, deceased who died on 7 December 1986 and Probate of whose Will was granted by the Supreme Court of Victoria in its Probate Jurisdiction on 17 July 1987 are required to send particulars of their claims to the executor care of Minter Ellison of 379 Collins Street, Melbourne by 5 October 1987 after which date the executor will distribute the assets of the estate having regard only to the claims of which they then have had notice.

8074

In the Supreme Court of the State of Victoria  
SALE BY THE SHERIFF

On 3 September 1987, at 2.00 p.m. at Warrnambool Police Station (unless process be stayed or satisfied).

All the estate and interest (if any) of Robert Williamson of 3 Sundale Road, Warrnambool shown on Certificate of Title as Robert Martin Williamson, proprietor of an estate in fee simple in the land described in the Certificate of Title Volume 8934 Folio 689 upon which is erected a dwelling and known as 3 Sundale Road, Warrnambool.

Registered mortgage K365553 affects the said estate and interest.

Terms—Cash only  
8083 A. STANLEY, Sheriff's Officer

In the Supreme Court of the State of Victoria  
SALE BY THE SHERIFF

On 3 September 1987, at 2.30 p.m. at the Sheriff's Office, 287 Springvale Road, Glen Waverley (unless process be stayed or satisfied).

All the estate and interest (if any) of Peter J. Hudson and Linda J. Hudson of 4 Tara Court, Wantirna, shown on Certificate of Title as Peter John Hudson and Lynda Janice Hudson, joint

proprietors of an estate in fee simple in the land described on the Certificate of Title Volume 8947 Folio 222 upon which is erected a dwelling and known as 4 Tara Court, Wantirna.

Registered mortgages H683957, L259483B and Caveats M116580E, M844579J affects the said estate and interest.

Terms—Cash only

8084 A. STANLEY, Sheriff's Officer

**NOTICE OF MAKING OF  
STATUTORY RULES  
WHICH ARE NOT YET  
AVAILABLE**

Notice is given of the making of the following Statutory Rules:

	<i>Motor Car Traders Act</i> 1986
190/1987	Motor Car Traders Regulations 1987
	<i>Consumer Affairs Act 1972</i>
191/1987	Consumer Affairs (Product Safety) (Children's Toys) Regulations 1987
	<i>Chattel Securities Act 1987</i>
192/1987	Chattel Securities Regulations 1987
	<i>Environment Protection Act</i> 1970
193/1987	Environment Protection (Transport) Regulations 1987
	<i>Environment Protection Act</i> 1970
194/1987	Environment Protection (Fees) (Amendment) Regulations 1987
	<i>Environment Protection Act</i> 1970
195/1987	Environment Protection (Prescribed Waste) Regulations 1987
	<i>Environment Protection Act</i> 1970
196/1987	Environment Protection (Scheduled Premises and Exemptions) (Amendment) Regulations 1987
	<i>Environment Protection Act</i> 1970
197/1987	Environment Protection (MMBW Exemption) Regulations 1987

**NOTICE OF MAKING  
AND AVAILABILITY OF  
STATUTORY RULES**

In pursuance of the provisions of the *Subordinate Legislation Act 1962* and the Regulations made thereunder notice is given of the making and availability of the following Statutory Rules:

Note: The date specified after each Statutory Rule is the date it was first obtainable from—

VGPO Bookshop  
Information Victoria Centre  
318 Lt Bourke Street, Melbourne

		24 July 1987		40c
			<i>Extractive Industries Act 1966</i>	
		184/1987	Extractive Industries (Board of Examiners Fees) Regulations 1987	
		24 July 1987		40c
			<i>Mines Act 1958</i>	
		185/1987	Mines (Board of Examiners Fees) Regulations 1987	
		24 July 1987		40c
			<i>Public Service Act 1974</i>	
		186/1987	Public Service (Amendment) Regulations (No. 4) 1987	
		24 July 1987		40c
			<i>Racing Act 1958</i>	
		187/1987	Racing (Off-Course Totalizator) (Amendment) Regulations 1987	
		24 July 1987		40c
			<i>Racing Act 1958</i>	
		188/1987	Racing (On-Course Totalizator) (Further Amendment) Regulations 1987	
		24 July 1987		40c
			<i>Chattel Securities Act 1981</i>	
		189/1987	Chattel Securities (Amendment) Regulations 1987	
		24 July 1987		40c
			<i>Public Service Act 1974</i>	
		PSD28/1987	Public Service Determinations (No. 28) 1987	
		PSD29/1987	Public Service Determinations (No. 29) 1987	
		PSD30/1987	Public Service Determinations (No. 30) 1987	
		24 July 1987		40c
			<i>Forests Act 1958</i>	
		183/1987	Forests (Part V—Timber Promotion) (Amendment) Regulations 1987	

178/1987 Dried Fruits (Allowances of Board Members) Regulations 1987

24 July 1987 40c

*Farm Produce Merchants and Commission Agents Act 1965*

179/1987 Farm Produce Merchants and Commission Agents (Disputes Committee Fees) Regulations 1987

24 July 1987 40c

*Stock Medicines Act 1958*

180/1987 Stock Medicines (Fees No. 2) Regulations 1987

24 July 1987 40c

*Crimes (Confiscation of Profits) Act 1986*

181/1987 Crimes (Confiscation of Profits) Regulations 1987

24 July 1987 40c

*Reference Areas Act 1978*

182/1987 Reference Areas (Advisory Committee—Remuneration and Allowances) (Amendment) Regulations 1987

24 July 1987 40c

## CONTENTS

	Page
Appointments	2010
Cemeteries—Scale of Fees	1994
Contracts	1995
Contracts Accepted—Amendments	2031
Estates of Deceased Persons	2003
Government Notices	1994
Notice of Making of Statutory Rules	2056
Orders in Council—	
Acts—Melbourne Wholesale Fruit and Vegetable Market Trust; Crown Land (Reserves); Ambulance Services; Forests; Urban Land Authority; Local Government; Parliamentary Committees; Water and Sewerage Authorities (Restructuring); Latrobe Valley; Building Society; Water and Sewerage Authorities (Restructuring); Local Government; Water and Sewerage Authorities (Restructuring).	2012
Private Notices	2033
Proclamations	1992
Resignations	2011
Tenders	2031

**No. G 29—General Government Gazette**

A Victorian Government Publication

Published by VGPO

Melbourne Victoria Australia

© State of Victoria

This publication is copyright. No part may be reproduced by any process except in accordance with the provisions of the Copyright Act

Address all inquiries to the Government Printer for the State of Victoria  
PO Box 203 North Melbourne 3051 Victoria Australia  
ISSN 0819—5471

Further copies of this publication can be obtained from  
VGPO Bookshop  
Information Victoria Centre  
318 Lt Bourke Street Melbourne  
(PO Box 203 North Melbourne 3051)

By Authority F D Atkinson Government Printer Melbourne  
**Recommended Retail Price \$1.10**