

# VICTORIA GOVERNMENT G A Z E T T E

No. G 21 Wednesday 31 May 1989

By Authority Jean Gordon Government Printer Melbourne

**GENERAL**

## Gazette Services

The *Victoria Government Gazette* (VGG) is published by VGPO for the State of Victoria and is produced in three editions.

VGG General is published each Wednesday and provides information regarding Acts of Parliament and their effective date of operation; Government notices; requests for tenders; as well as contracts and contracts accepted. Private notices are also published.

VGG Special is published any day when required for urgent or special Government notices. VGG Special is made available automatically to subscribers of VGG General.

VGG Periodical is published on Monday when required and includes specialised information eg. Medical, Dental, Pharmacist's Registers, etc.

## Government Advertising

### Publishing Details

The following Guidelines should be followed to ensure publication of Government material in the *Victoria Government Gazette*.

- Duplicate copies should be submitted for use by the Gazette Officer.
- Material submitted to the Executive Council for gazettal will normally be published in the following week's issue.
- Where urgent gazettal is required, contact:  
Gerd Gaspar  
Gazette Officer  
Department of the Premier and Cabinet  
2nd Floor 1 Treasury Place  
Melbourne 3000  
Telephone Inquiries (03) 651 5153
- Government advertising other than material for the consideration of the Executive Council should be forwarded to the Gazette Office no later than 9.30 am on Tuesday.
- Lengthy or complicated notices should be forwarded several days before publication.
- Proofs will be supplied only when requested or at the direction of the Gazette Officer.
- No additions or amendments to material for publication will be accepted by telephone.
- Double rates for advertising in the Special Gazette will apply.

## Private Advertising

### Publishing Details. Send copy to:

VGG Coordinator  
Gazette Advertising  
VGPO  
66-112 Macaulay Road  
North Melbourne  
(PO Box 203 North Melbourne 3051)  
Telephone inquiries (03) 320 0100  
Fax No. (03) 329 2696

### Advertising Rates and Payment

Single column × cm/part cm \$3.85  
Double column × cm/part cm \$7.70  
Full page \$161.70

All private advertising MUST be paid for in advance, prior to any gazettal. Cheques should be made payable to 'VGPO'.

### Advertisers should note:

- There are approximately 20 words to each column centimetre depth.
- Signatures (in particular) and proper names must also be in block letters.
- All material should be double spaced.
- Advertisements can be faxed, and a cover sheet should be used, marked to the attention of the Gazette Coordinator.
- Documents not clearly prepared and in the exact format for gazettal will be returned to the sender unpublished.
- Late copy received at VGPO after 3.30 pm Tuesday will be placed in the following issue of VGG, irrespective of any date/s mentioned in the copy (unless otherwise advised).

### Copy Deadline

11.00 am Tuesday (Normal Rates)  
3.30 pm Tuesday (Double Rates)

## Subscriptions

VGG is available by three subscription services:

General and Special—\$111.50 each year  
General, Special and Periodical—\$128 each year  
Periodical—\$67 each year

Subscriptions are payable in advance and accepted for a period of one year. All subscriptions are on a firm basis and refunds for cancellations will not be given.

All payments should be made payable to VGPO.  
Subscription inquiries: (03) 320 0217  
Bookshop Inquiries: (03) 663 3760

**PROCLAMATIONS**

**PROCLAMATION**

**Assumption of Office as Administrator**

The Governor will be absent from the State from Thursday, 25 May until Saturday, 29 July 1989.

The Premier has requested in writing that I assume office as Administrator.

In accordance with Her Majesty's Letters Patent relating to the Office of the Governor of Victoria I, John McIntosh Young, Lieutenant-Governor, have therefore assumed office as Administrator from Thursday, 25 May to Saturday, 29 July 1989.

Given under my hand and the seal of  
Victoria on 25 May 1989

(L.S.) J. McI. YOUNG

By His Excellency's Command  
JOHN CAIN  
Premier

*Agricultural Chemicals Act 1958*

**PROCLAMATION**

Prescribing Tributyl Tin to be a Prohibited Constituent of any Agricultural Chemical used other than for certain purposes

I, Sir John McI. Young, Administrator of Victoria, acting with the advice of the Executive Council and under sections 6A and 10A of the *Agricultural Chemicals Act 1958*:

1. Amend the Proclamation made on 20 January 1987 and published in the *Government Gazette* on 21 January 1987, as amended by proclamations made on 28 July 1987, and 29 November 1988 and published respectively in the *Government Gazette* on 29 July 1987 and 30 November 1988 by adding the following item 41 to the Schedule of the Proclamation—

**SCHEDULE**

<i>Column 1</i> Prohibited Substance	<i>Column 2</i> Purpose
41. Tributyl tin	As an agricultural chemical except where written consent has been given by the Environment Protection Authority.

Given under my hand and the seal of  
Victoria on 30 May 1989.

(L.S.) J. McI. YOUNG

By His Excellency's Command  
BARRY ROWE  
Minister for Agriculture and Rural Affairs

*Agricultural Chemicals Act 1958*

**PROCLAMATION**

**Prescribing a Standard for Tributyl Tin**

I, Sir John McI. Young, Administrator of Victoria, acting with the advice of the Executive Council and under sections 4 and 6A of the *Agricultural Chemicals Act 1958* declare the standard for tributyl tin to be a maximum leaching rate into water of 5 micrograms per square centimetre per day of tributyl tin from painted surfaces.

Given under my hand and the seal of  
Victoria on 30 May 1989.

(L.S.) J. McI. YOUNG

By His Excellency's Command  
BARRY ROWE  
Minister for Agriculture and Rural Affairs

**GOVERNMENT NOTICES**

**STATE ELECTORAL OFFICE VICTORIA**  
**Notice of Application for Registration of a**  
**Political Party**

The following application has been received for registration of a political party under the provisions of *The Constitution Act Amendment Act 1958*.

*Name of party:* Grey Power.

*Name and address of registered officer:* Ronald James Letten 35-39 McIntosh Street, Airport West, Victoria, 3042.

The application is made, and signed by, ten members of the party. The application states their names and addresses as follows:

- R. J. Letten, 6 Burnside Avenue, Canterbury.
- B. F. Walsh, 14 Merchiston Grove, Strathmore.
- M. L. Vassallo, 5 Miriam Court, Airport West.
- R. Woodgate, 27 Toolern Street, Melton South.
- S. McDonald, 238 The Avenue, Parkville.
- A. Bernadou, 41 Heads Road, Donvale.
- K. Agius, 71 William Street, Glenroy.
- D. Hassard, 86 Carnarvon Road, Strathmore.
- H. Rothwell, 31 Lind Street, Strathmore.
- S. A. Letten, 6 Burnside Avenue, Canterbury.

In its application the party states that it has or operates under a constitution, a copy of which accompanied the application.

Any persons who believe that this application:

- (i) does not relate to an eligible political party;
- (ii) is not in accordance with section 148D of *The Constitution Act Amendment Act 1958*;
- (iii) should not be considered by reason of section 148F of *The Constitution Act Amendment Act 1958*; or
- (iv) should be refused under section 148G of *The Constitution Act Amendment Act 1958*;

are invited to submit written particulars of the grounds for that belief to the Electoral Commissioner within one month of the date of publication of this notice.

Particulars submitted by a person in response to this notice must be signed by, and specify an address of, that person and must be sent to the Electoral Commissioner, State Electoral Office, Ninth Floor, 30 Collins Street, Melbourne, Vic., 3000.

This notice is placed as required by section 148K of *The Constitution Act Amendment Act 1958*.

G. P. LYONS  
 Electoral Commissioner

Regulations

**SANDALONG PARK, MILDURA**

I, Kay Setches, Her Majesty's Minister for Conservation, Forests and Lands for the State of Victoria, in pursuance of the powers conferred on me by section 13 of the *Crown Land (Reserves) Act 1978* do hereby make the following regulations for or with respect to the remaining Crown lands in the Parish of Mildura temporarily reserved as sites for Public Recreation by Orders in Council of 10 October 1932, 18 November 1935, 26 July 1948 and 27 April 1977 and known as Sandalong Park (hereinafter called "the Reserve") in respect of which a Committee of Management (hereinafter called "the Committee") has been appointed.

Regulations

1. The Reserve shall be open to the public free of charge except on such days as the Reserve may be set apart for sporting or athletic events, shows, fetes, musical performances, outdoor gatherings or holiday amusements, or any other special event, on any of which occasions an admission fee may be charged.
2. No person shall—
  - (a) Enter or remain in the Reserve who may offend against decency as regards dress, language or conduct, or who may behave in a disorderly or offensive manner, or create or take part in any disturbance.
  - (b) Carry or discharge any firearm or airgun in the Reserve.
  - (c) Obstruct, hinder or interfere with any person under authority from or employed by the Committee at the Reserve.
  - (d) Bring or sell or distribute in the Reserve, any intoxicating liquor unless authorised in writing by the Committee and holding a licence or permit as required pursuant to the provisions of the Liquor Control Act and then only in such place or places, or portion of the Reserve as may be set apart for the purpose by the Committee.
  - (e) Gamble publicly in any part of the Reserve without permission in writing of the Committee first obtained.
  - (f) Light a fire in the Reserve except at such places as are set apart for the purpose by the Committee.
  - (g) Damage or remove any trees, shrubs, plants or flowers in the Reserve.
  - (h) Remove any earth, sand, stones, marble, gravel or any other material from the Reserve.

- (i) Exercise or train any horse or pony on the Reserve or any part hereof without the consent in writing of the Committee.
  - (j) Cause or permit any outcry, sound or noise to be emitted from an amplifier, loud speaker, public address system or like instrument without first obtaining the written permission of the Committee and such permission may be granted subject to such terms, conditions and restrictions as may be imposed by the Committee.
  - (k) Deposit or leave any glass bottle, tin can, waste paper, garbage or litter of any kind in the Reserve except in a receptacle provided for that purpose by the Committee.
  - (l) Damage or injure in any way any of the buildings and fittings, gates, fences, seats or any other property in the Reserve and in the event of such damage occurring, the person, club or other organisation responsible shall pay the Committee the cost of making good and repairing such damage.
  - (m) Enter the Reserve or pass over the playing area or oval with any vehicle or on horseback without the permission of the Committee first obtained, nor ride or drive amongst or to the danger or annoyance of persons assembled on any part of the Reserve.
  - (n) Commit any nuisance in the Reserve.
  - (o) In or upon the Reserve, kill, wound, trap or snare, or attempt to kill, wound, trap or snare, any bird or other native game, or have any dead bird or native game or skin or pelt thereof in his/her possession.
3. The Committee shall have the power to hold sporting and athletic events, entertainments, shows or performances in the Reserve, and to make a charge for admission thereto as herein provided.
4. The Committee shall have power to let any portion of the Reserve to any club, association, person or society, for the purpose of holding entertainment, performances, shows or sports, subject to the payment of such fees and on such terms as it may be deemed to be reasonable and consistent with these regulations, and to authorise any club, association, society or person to make a charge for admission thereto as provided herein before.
5. No club, association, society or person shall hold any event, entertainment, performance show or ceremony in any part of the Reserve without the authority of the Committee.
6. No person except the Committee or its Officers or employees on duty shall enter any

part of the Reserve when a charge is made for admission without first paying the fees chargeable for admission.

7. No person shall park a motor car vehicle or motorcycle within the Reserve except at such places as are set apart for the purpose by the Committee.

8. No person shall put in the Reserve any cattle, horses, sheep, goats, pigs or any other animals without the permission in writing of the Committee first obtained. All dogs must at all times be controlled by a chain or leash within the Reserve.

9. No person shall camp in the Reserve or erect herein any building or any other structure without the consent in writing of the Committee being first obtained.

10. No person shall sell or offer for sale in the Reserve any article without the prior permission in writing of the Committee and then to such conditions as the Committee may determine.

11. No person shall erect or display any signs, advertising material or notices within the Reserve without the permission of the Committee in writing.

These Regulations are in lieu of all previous Regulations, relating to the said lands, which are hereby rescinded.

Given under my hand at Melbourne on 26 May 1989.

K. P. SETCHES

Minister for Conservation, Forests and Lands

Every person who contravenes or fails to comply with these regulations shall be liable to the penalties prescribed in section 13 of the *Crown Land (Reserves) Act 1978*.

#### REGULATIONS FOR THE CARE PROTECTION AND MANAGEMENT OF THE TEESDALE RECREATION RESERVE

I, Kay Setches, Her Majesty's Minister of Conservation, Forests and Lands in the State of Victoria in pursuance of the powers conferred on me by section 13 of the *Crown Land (Reserves) Act 1978* do hereby make the following regulations for or with respect to the Crown land in the Township of Teesdale, Parish of Carrah temporarily reserved for Public Recreation by Order in Council dated 5 November 1986 (hereunder called the "Reserve") in respect of which a Committee of Management (hereinafter referred to as the "Committee") has been appointed.

1. No person shall—

- (a) Enter or remain in the Reserve who behaves in a disorderly manner or creates or takes part in any disturbance or

commits any act of indecency as regards dress, language or conduct.

- (b) Light or cause to be lit any fire in the Reserve except in fire places as may be provided by the Committee.
- (c) Deposit in the Reserve any lighted tobacco, cigarette, cigar or match or any other burning material or thing within the reserve.
- (d) Bring or allow any animal to graze or trespass in the area.
- (e) Obstruct, disturb or annoy any officer or employee of the Committee in the lawful execution of his work or duty.

2. No person shall unless authorised in writing by the Committee—

- (a) Carry or bring into the Reserve traps, poisons, snares, firearms or any weapon capable of discharging a missile.
- (b) Deposit in the Reserve any rubbish, litter or refuse of any kind except in receptacles for that purpose, nor post bills on fences gates or trees or paint names or letters, marks or other matter on trees, gates, post or fences or otherwise deface same nor break, cut dig-up, damage or injure in any way or take away the whole or portion of any tree, shrub, plant, seed, undergrowth, fern, flower, property, soil or any vegetation in the Reserve.
- (c) Remove, displace or damage any board or fitting for the exhibition of any regulations or any notice fixed or set up in the Reserve.
- (d) Ride or drive any vehicle, motor or otherwise, within the Reserve, except on the roadways, and then only at a speed not exceeding 10 km/h.
- (e) Camp nor erect or place any building, tent, booth or other structure in any part of the reserve.

Every person infringing these Regulations in any respect shall be liable to expulsion from the Reserve in addition to any other penalty to which such person may be liable—(Rs. 13314).

Given under my hand at Melbourne on 26 May 1989.

K. P. SETCHES  
Minister for Conservation, Forests and Lands

Every person who contravenes or fails to comply with these Regulations shall be liable to the penalties prescribed in section 13 of the *Crown Land (Reserves) Act 1978*.

AMENDMENT TO THE REGULATIONS  
FOR THE CARE, PROTECTION AND  
MANAGEMENT OF THE RESERVE FOR  
PUBLIC PARK AND GARDEN AND FOR  
RECREATION AND CAMPING PURPOSES  
IN THE TOWNSHIP OF WARRAGUL

I, Kay Setches, Her Majesty's Minister for Conservation, Forests and Lands in and for the State of Victoria in pursuance of the powers conferred on me by section 13 of the *Crown Land Reserves Act 1978*, do hereby amend the Regulations made on 22 January 1952 (see *Government Gazette* dated 30 January 1952) and amended from time to time, the last time being 4 October 1983 (see *Government Gazette*, dated 12 October 1983 page 3351) for or with respect to the above Reserve as follows:

Regulation 9 of the said Regulations shall be amended to read—

“The charges for camping in the portion or portions determined from time to time apart for the purpose shall be set by the Council of the Shire of Warragul”.

Given under my hand at Melbourne on 26 May 1989.

K. P. SETCHES  
Minister for Conservation, Forests and Lands—  
(Rs. 2541).

REGULATIONS FOR THE CARE,  
PROTECTION AND MANAGEMENT OF  
THE FYANSFORD RECREATION  
RESERVE

I, Kay Setches, Her Majesty's Minister for Conservation, Forests and Lands in the State of Victoria in pursuance of the powers conferred on me by section 13 of the *Crown Land (Reserves) Act 1978* do hereby make the following Regulations for or with respect to the Crown Land in the Township of Fyansford, Parish of Gheringhap, temporarily reserved for Public Recreation by Order in Council dated 20 November 1984 (hereinafter called the reserve) in respect of which a Committee of Management (hereinafter referred to as the “Committee”) has been appointed.

*Entry to the Reserve*

1. (a) The Reserve shall be open to the public from sunrise to sunset, free of charge except on the days and between the hours determined by the Committee from time to time.

(b) The Committee may close the Reserve or any part thereof at any time for cleaning maintenance or other works or if in the opinion of the Committee undue risks will arise if the Reserve remains open to the public.

(c) The Committee may fix fees for entry to or use of the Reserve from time to time.

1290 G 21 31 May 1989

(d) No person shall enter or use the Reserve without first paying the fee fixed by the Committee or pursuant to these Regulations for such entry or use.

(e) Membership tickets tokens or licences issued to any person for entry to or use of the Reserve shall not be transferable to any other person.

(f) No person shall without the authority of the Committee enter or remain within or use the Reserve or any part of the Reserve at any time during which it is closed to the public.

#### *Removal of Persons from a Reserve*

2. (a) Any person who offends against these Regulations or who in the opinion of the Committee is about to offend against these Regulations shall if requested by the Committee or an Officer of the Committee immediately leave the Reserve.

(b) An Officer of the Committee may remove from the Reserve any person who refuses to obey a direction to leave.

#### *Officers and Employees*

3. (a) Nothing in these Regulations shall prevent any of the Committee, member of the Police Force, contractor of the Committee or workman employed by a contractor from doing such things and taking such action as may be required in the course of his or her duties.

(b) No person shall interfere with, hinder or obstruct an employee of the Committee in the course of his or her duties within the Reserve.

(c) Every person within the Reserve shall obey the lawful directions of any employee of the Committee or member of the Police Force.

#### *Behaviour within Reserves*

4. No person shall:

- (a) Interfere with, break, damage, remove, displace or deface any vegetation garden bed, pavement, seat, table, fence, fixture, building improvement or structure within the reserve whether affixed thereto or not;
- (b) Throw or roll any stone or missile or carry or shoot any firearm within the Reserve;
- (c) Bring any refuse rubbish litter or offensive material into the Reserve or deposit or leave any refuse rubbish litter or offensive material within the reserve except in the receptacle provided for the purpose;
- (d) Commit or create any public or private nuisance or any annoyance to the public or any persons lawfully in the Reserve or behave in a disorderly indecent or offensive manner or create a disturbance, or use offensive or insulting language;

#### *Victoria Government Gazette*

- (e) Make any unreasonable noise or play any instrument or other sound producing device so as to cause annoyance to interfere with the enjoyment of any other persons within the Reserve;
- (f) Enter or remain within the Reserve whilst in a state of intoxication or whilst under the influence of a hallucinatory drug;
- (g) Permit or allow any animal owned by him or her to enter or remain within the Reserve provided however that dogs kept at all times under proper control on a chain cord or leash may enter the Reserve;
- (h) Play or practice any cricket football bowls tennis golf or other like game or any organised sport within the Reserve or any part of the Reserve where a sign is displayed indicating that such activities are not permitted;
- (i) Interfere with, interrupt or obstruct any sports match, sports gathering or game being played within the reserve on a sports ground or playing area set aside for the purpose of such sport or game;
- (j) Drive or park any vehicle within the Reserve except on or within a roadway or parking area set aside for that purpose provided however, that nothing herein contained shall prevent any officer or employee of the Committee from driving or parking a vehicle within the Reserve in the course of his or her duties;
- (k) Ride any horse within the Reserve except within the Reserve or part of the Reserve set aside for that purpose;
- (l) Kill or injure any animal or bird within the Reserve;
- (m) Being over the age of fourteen years use any playground equipment or enter or remain in any playground between the hours of sunset or sunrise;
- (n) Enter or use any part of the Reserve for the time being set apart or appropriated for the use of the opposite sex except a child under the age of four years in the care of a responsible person;
- (o) Bring or come to be brought into the Reserve any unregistered or uninsured motor cycle or recreation type vehicle;
- (p) Use any minibike, trailbike or similar recreation type vehicle on the Reserve without the written authority of the Committee and then only under such conditions as may be determined by the Committee.

#### *Activities requiring a Permit*

5. No person shall except in accordance with a permit in writing:

- (a) Sell or offer for sale any article whatsoever within the Reserve;
- (b) Camp within the Reserve;
- (c) Light a fire or permit a fire to remain alight within the Reserve except in a fireplace provided for that purpose.

*Permits*

6. (a) Any application for a permit shall be in writing in such form as the Committee may determine from time to time.

(b) Any permit issued by the Committee may be limited in time or in its operation and where in the opinion of the Committee which has issued a permit, there has been a material change in circumstances or in the condition of the Reserve or where the terms or conditions attaching to any permit have not been complied with then the Committee may amend or revoke the permit.

(c) The Committee may from time to time fix and collect a fee for issue of any permit—(Rs 12861).

Given under my Hand at Melbourne on 26 May 1989

K. P. SETCHES

Minister for Conservation, Forests and Lands

Every person who contravenes or fails to comply with these Regulations shall be liable to the penalties prescribed in section 13 of the *Crown Land (Reserves) Act 1978*.

*Transport Act 1983*

**ROAD TRAFFIC AUTHORITY**

**Commercial Passenger Vehicle and Tow Truck Applications**

Notice is hereby given that the following applications will be considered by the Road Traffic Authority on 4 July 1989.

Notice of any objections should be forwarded to reach the Manager, Vehicle Licensing Branch or any Regional Office of the Road Traffic Authority not later than 28 June 1989.

It will not be necessary for interested parties to appear on the hearing date specified, unless advised in writing by the Authority.

Notification of the date for consideration of applications which are objected to and which require determination by the Road Transport Licensing Tribunal will be published by further notice in this Gazette.

Abcrest Pty. Ltd., Moorabbin. Application to license three commercial passenger vehicles, to be purchased in respect of the following: one 1980 or later model Cadillac stretched limousine with seating capacity for 7-8 passengers; one 1987 or later model Nissan Patrol with seating capacity for 6 passengers; and either a 1987 or later model Toyota Tarago, a 1987 or later model Nissan

Nomad or a 1987 or later model VW Caravelle with seating capacity for 6-7 passengers; to operate as metropolitan hire cars from 64 Mortimore Street, Moorabbin.

G. P. Beardsley, Berwick. Application to license one commercial passenger vehicle in respect of a 1981 Statesman De Ville sedan with seating capacity for 4 passengers to operate as a special purpose vehicle from 7 Graneel Grove, Berwick for the carriage of passengers for wedding parties.

*Note:* This application is made in addition to an application which appeared in the *Victoria Government Gazette* No. G11 dated 15 March 1989, in the name of the applicant.

Cambro Nominees Pty. Ltd., Clayton North. Application to license three class 2 tow trucks to be purchased to operate throughout the State of Victoria from a depot situated at 53 Sarton Road, Clayton North for the purpose of lifting and carrying or towing damaged or disabled motor cars excluding the ability to attend the scene of a motor car accident.

R. E. and V. J. Campbell, Leopold. Application for variation of the conditions of tow truck licence number 338 which authorises the licensed vehicle to:

- (i) be managed controlled and operated from a depot situated at 15 Douro Street, North Geelong; and
- (ii) operate throughout the State of Victoria as a tow truck in the course of business as "motor wrecker" for the purpose of lifting and carrying or towing and/or repairing of wrecked, disabled or repossessed vehicles—tools of trade, spare parts and materials incidental thereto, but excluding the right to operate the vehicle as a tow truck to or from the scenes of accidents or collisions.

To vary the conditions to:

- (i) change the depot address to 12 Gravelpits Road, South Geelong; and
- (ii) add the ability to lift carry and tow, vehicles not owned by the licence holder.

*Note:*

- (i) This licence is currently under consideration for transfer to Grant's Auto Wreckers Pty. Ltd. of South Geelong.
- (ii) Notice of this application replaces notices which appeared in the *Victoria Government Gazette*, Nos. G8 dated 22 February 1989 and G16 dated 26 April 1989 in the names of R. E. and V. J. Campbell.
- (iii) Previous objections to the granting of this application are invalid and interested parties are advised that a new notice of objection must be submitted.

1292 G 21 31 May 1989

*Victoria Government Gazette*

G. J. Ceniti, East Brunswick. Application to license three commercial passenger vehicles to be purchased in respect of two 1979 Jaguar sedans and one 1955 Bentley sedan with seating capacity for 4 and 6 passengers respectively to operate as special purpose vehicles from 134 McBryde Street, Fawkner for the carriage of passengers for wedding parties.

Corpstreet Pty. Ltd., North Clayton. Application to license one class 1 and one class 2 tow truck to be purchased to operate throughout the State of Victoria from a depot situated at 44 Renver Road, North Clayton for the purpose of lifting and carrying or towing damaged or disabled motor cars excluding the ability to attend the scene of a motor car accident.

H. J. Craddock, Colac. Application for variation of the conditions of tow truck licence number 325 which authorises the licensed vehicle to be managed, controlled and operated from a depot situated at 370 Murray Street, Colac to change the depot address to Princes Highway, Colac West.

F. & R. Martin Pty. Ltd., Albury. Application to license one commercial passenger vehicle in respect of a 1982 Mazda bus with seating capacity for 18 passengers to operate a service for the carriage of employees of Best Foods between Albury, Wodonga and Wahgunyah.

*Fares:* By agreement with the hirer.

*Timetable:* As and when required.

J. M. Gilliland, Alphington. Application to license three commercial passenger vehicles in respect of one 1952 Cadillac sedan, one 1952 Cadillac convertible and one 1957 Cadillac sedan each with seating capacity for 5 passengers to operate as special purpose vehicles from 13 Como Street, Alphington for the carriage of passengers for wedding parties, birthdays and anniversaries.

L. T. Lambert, Springvale North. Application to license one class 2 tow truck to be purchased to operate throughout the State of Victoria from a depot situated at 7 Smith Road, Springvale North for the purpose of lifting and carrying or towing damaged or disabled motor cars excluding the ability to attend the scene of a motor car accident.

D. La Selva, Lalor. Application to license two commercial passenger vehicles in respect of two 1978 Jaguar sedans each with seating capacity for 4 passengers to operate as metropolitan hire cars from 457 High Street, Lalor.

*Note:* This application is made in conjunction with a similar application by C. Pierri.

M. Mastos, Abbotsford. Application to license one commercial passenger vehicle to be purchased, in respect of a 1980-1986 Cadillac stretched limousine with seating capacity for 7

passengers to operate as a metropolitan hire car from 133 Yarra Street, Abbotsford.

Mazzro Nominees Pty. Ltd., North Clayton. Application to license two class 2 tow trucks to be purchased to operate throughout the State of Victoria from a depot situated at 1848 Dandenong Road, North Clayton for the purpose of lifting and carrying or towing damaged or disabled motor cars excluding the ability to attend the scene of a motor car accident.

R. Muller, North Clayton. Application to license one class 1 and two class 2 tow trucks to be purchased to operate throughout the State of Victoria from a depot situated at 71 Renver Road, Clayton for the purpose of lifting and carrying or towing damaged or disabled motor cars excluding the ability to attend the scene of a motor car accident.

K. M., L. & V. C. O'Connor, Bairnsdale. Application for variation of the condition of licence CC43 which authorises tours and charter rights from within a 20 km pick up radii of the Post Offices at Bairnsdale, Lakes Entrance and Orbost to include the ability to operate a school service between Wy Yung and Nagle College, Bairnsdale under contract to Nagle College, Bairnsdale.

E. Petras, North Carlton. Application to license one commercial passenger vehicle in respect of a 1985 Lincoln stretched limousine with seating capacity for 7 passengers to operate as a metropolitan hire car from 409B Blackshaw Road, North Altona.

C. Pierri, Rosanna. Application to license two commercial passenger vehicles in respect of a 1978 Jaguar sedan and a 1978 or later model Rolls Royce sedan each with seating capacity for 4 passengers to operate as metropolitan hire cars from 457 High Street, Lalor.

*Note:* This application is made in conjunction with a similar application by D. La Selva.

C. Ponsonby, Mulgrave. Application to license one class 2 tow truck to be purchased to operate throughout the State of Victoria from a depot situated at 47 Henderson Road, North Clayton for the purpose of lifting and carrying or towing damaged or disabled motor cars excluding the ability to attend the scene of a motor car accident.

E. A. Pugliese, Brighton. Application to license one commercial passenger vehicle in respect of a 1988 Ford Fairlane stretched limousine with seating capacity for 8 passengers, to operate as a metropolitan hire car from 98 Thomas Street, Hampton.

T. & G. Roberts & C. & V. A. Mennilli, Box Hill. Application to license ten commercial passenger vehicles in respect of the following:



Make	Year of Manufacture	Seating Capacity
Jaguar sedan	Series 3	4
Jaguar sedan	1974	4
Jaguar sedan	1978	4
Rolls Royce sedan	1972	4
Rolls Royce sedan	1970	4
Rolls Royce sedan	1975	4
Bentley sedan	1950	4
Bentley sedan	1951	4
Cadillac sedan	1974-1980	5
Cadillac sedan	1974	5

to operate as metropolitan hire cars from 362 Elgar Road, Box Hill.

Temple Body Works Pty. Ltd., Oakleigh South. Application to license three class 2 low trucks to be purchased to operate throughout the State of Victoria from a depot situated at 1366 North Road, Oakleigh South for the purpose of lifting and carrying or towing damaged or disabled motor cars excluding the ability to attend the scene of a motor car accident.

A. Todaro, Hoppers Crossing. Application to license eight commercial passenger vehicles in respect of the following:

Make	Year of Manufacture	Seating Capacity
Ford Fairlane sedan	1987	4
Ford Fairlane sedan	1987	4
Jaguar sedan	1980	4
Jaguar sedan	1980	4
Statesman sedan	1989	4
Statesman sedan	1989	4
Mercedes Benz sedan	1974	4
Mercedes Benz sedan	1975	4

to operate as metropolitan hire cars from 2 Hogans Road, Hoppers Crossing.

Note: This application is made subject to the cancellation of eight special purpose vehicle licences held by the applicant.

G. I. Unwin, Aspendale. Application to license four commercial passenger vehicles to be purchased, in respect of two 1984 or later model Jaguar sedans, one 1988 or later model Ford LTD and one 1989 Statesman sedan each with seating capacity for 4 passengers to operate as metropolitan hire cars from 42 Glen Street, Aspendale.

G. SHANKS  
Manager  
Vehicle Registration

ROAD TRAFFIC AUTHORITY

Mass Limits Increase Permits

In accordance with section 720 (2) of the Road Safety (Vehicles) Regulations 1988 the Councils of the Municipalities listed below have authorised the Road Traffic Authority to issue permits allowing vehicles to be used on any road within the Municipality which is not a State Highway, Main Road, Tourists' Road, Forest Road or Freeway within the meaning of the Transport Act, subject to the conditions that:

travel shall not be authorised over any roads specified in this notice or those signposted with lower limits than allowed under these permits; and

permit issue shall be limited to the Option A limits described by the Review of Road Vehicle Limits.

Municipality

Shire of Ballarat

IAN F. X. STONEY  
Managing Director

Transport Act 1983

NOTICE DECLARING NEW ROADS TO BE FIT TO BE USED AS PUBLIC HIGHWAYS

The Road Construction Authority is of the opinion that the new roads as set out below are fit to be used as public highways—

The new road in the Shire of Warragul shown hatched on plan numbered GP17909.

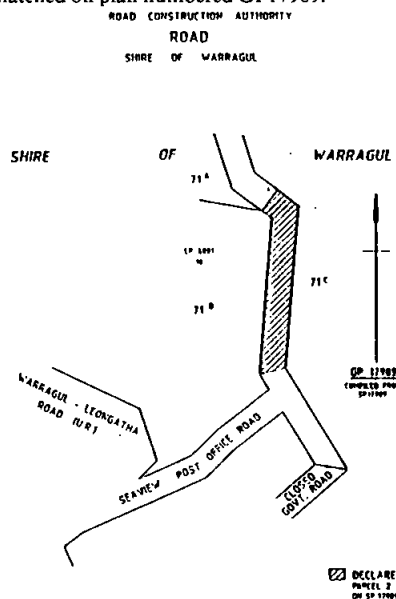

1294 G 21 31 May 1989

In accordance with the provisions of Clause 2 (2), Schedule 5 of the *Transport Act* 1983, the new roads shall, upon the publication of this notice in the *Government Gazette*, become and be absolutely dedicated to the public as public highways within the meaning of any law now or hereafter in force.

Dated 25 May 1989

R. H. SOLLY  
 Manager  
 Road Design and Traffic Branch  
 Road Construction Authority

*Transport Act* 1983

**DECLARATIONS AND DEDICATIONS OF ROADS**

The Road Construction Authority, in pursuance of the powers conferred by the *Transport Act* 1983, declares the roads or parts of roads or any deviations from or widenings of roads to be as described below; and further declares that any such new roads, deviations or widenings made by the Authority are fit to be used as public highways—

14/89 The new road (Princes Freeway) in the Shire of Pakenham shown hatched on plans numbered GP16407, GP16408, GP16409, GP16410, GP16411 and GP16413.

15/89 The widening of the Princes Highway in the Shire of Buln Buln shown hatched on plan numbered GP16825.

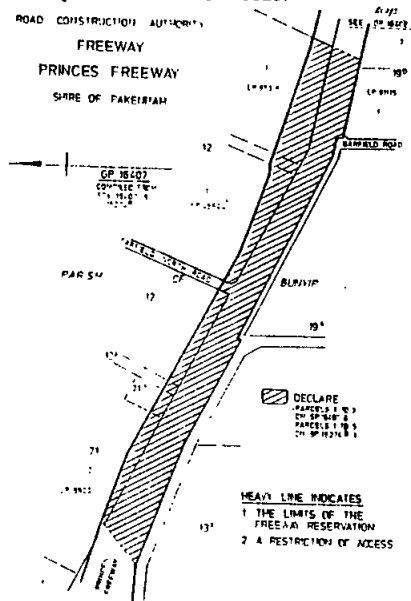

*Victoria Government Gazette*

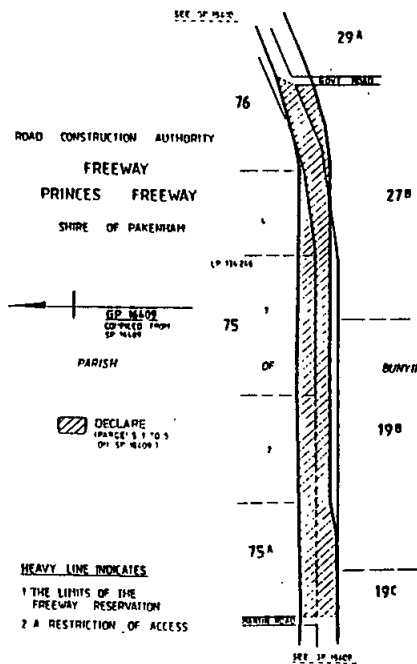
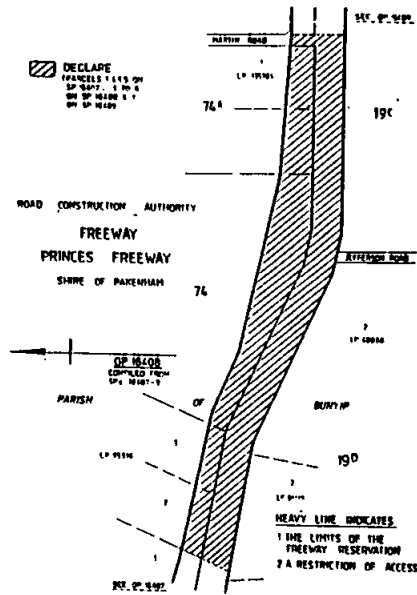

ROAD CONSTRUCTION AUTHORITY

FREWAY  
PRINCES FREEWAY  
SHIRE OF PAKENHAM

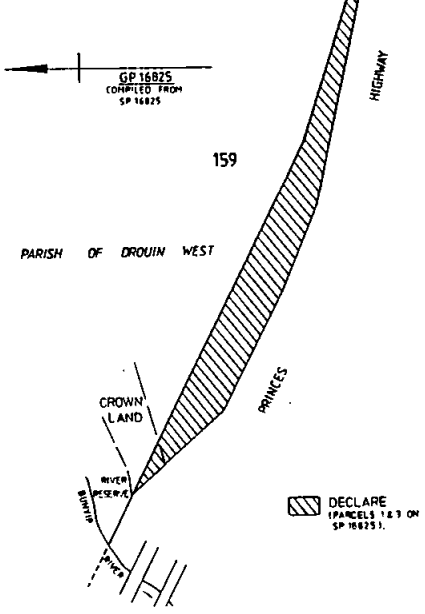
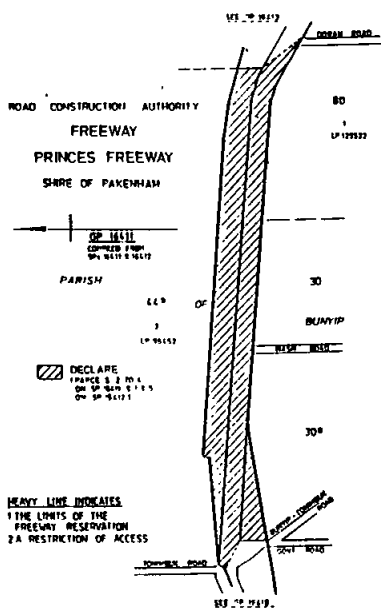
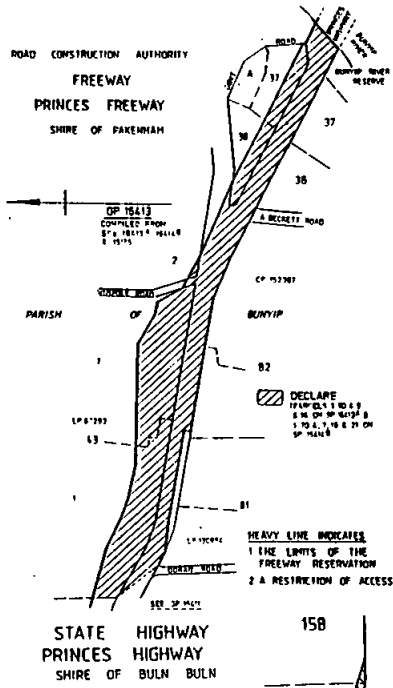
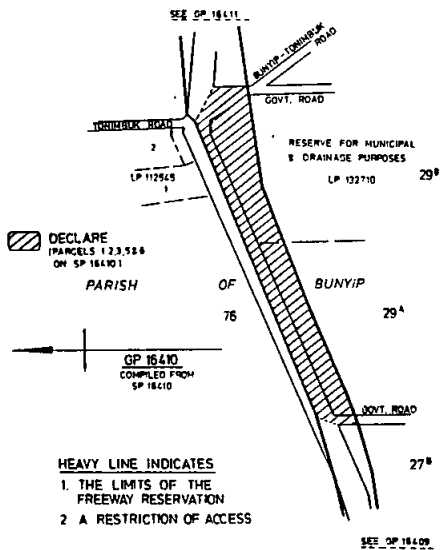

1296 G 21 31 May 1989

In accordance with the provisions of Clause 2 (2), Schedule 5 of the *Transport Act* 1983, the new roads, deviations or widenings made by the Authority shall, upon the publication of this notice in the *Government Gazette*, become and be absolutely dedicated to the public as a public highway within the meaning of any law now or hereafter in force.

Dated 25 May 1989

R. H. SOLLY  
 Manager  
 Road Design and Traffic Branch  
 Road Construction Authority

*Transport Act* 1983  
 VARIATIONS OF DECLARATIONS AND  
 DEDICATIONS OF ROADS

The Road Construction Authority, in pursuance of the powers conferred by the *Transport Act* 1983, varies the declarations of roads as described below; and further declares that any new roads, deviations or widenings made by the Authority and included in such variations are fit to be used as public highways—

17/89 By excluding from the declaration of the Princes Highway in the Shire of Pakénham the land shown cross hatched on plans numbered GP16410A and GP16413A.

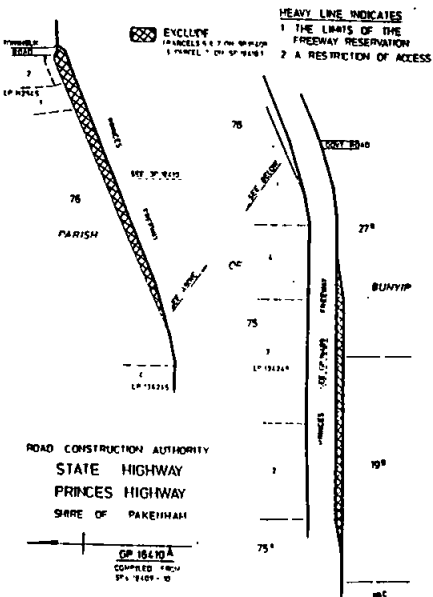

Victoria Government Gazette

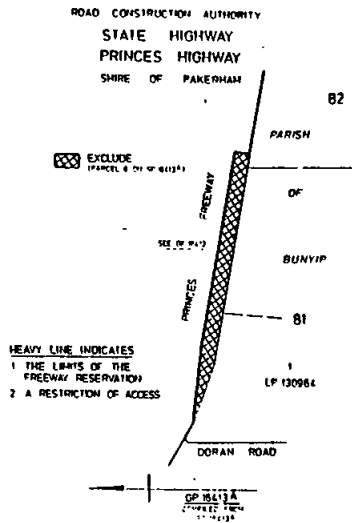

In accordance with the provisions of Clause 2 (2), Schedule 5 of the *Transport Act* 1983, the new roads, deviations or widenings made by the Authority shall, upon the publication of this notice in the *Government Gazette*, become and be absolutely dedicated to the public as a public highway within the meaning of any law now or hereafter in force.

Dated 25 May 1989

R. H. SOLLY  
 Manager  
 Road Design and Traffic Branch  
 Road Construction Authority

Department of Industry, Technology and  
 Resources

INTENTION TO GRANT MINING LEASE  
 No. 1657; ACI Operations Pty Ltd; 205.7 ha,  
 Parish of Beechworth.

APPLICATIONS FOR MINING LEASE  
 REFUSED

- No. 1522; E. E. Pascoe; 24.58 ha, Parish of Tarnagulla.
- No. 1531; Chartwest Mining NL & E. E. Pascoe; 82 ha, Parish of Tarnagulla.
- No. 1548; Cambrian Gold Mines; 35 ha, Tarnagulla.

APPLICATIONS FOR MINING LEASE  
 WITHDRAWN

- No. 1196; Western Mining Corporation Ltd; 47 ha, Parish of Moral Moral.
- No. 1863; M. C. Cox, R. G. Wilson & J. W. Carr; 163 ha, Parish of Corindhap.

APPLICATIONS FOR MINING LEASE  
ABANDONED

No. 1789; G. F. Thomas; 91.9 ha, Parish of Borung.

No. 1981; P. Wilson; 7.5 ha, Shire of Bet Bet.

INTENTION TO RENEW MINING LEASE

No. 1453; Martin Exploration Pty Ltd; 10 ha, Tongio-Munjie West.

APPLICATION FOR RENEWAL OF  
MINING LEASE REFUSED

No. 27-1; D. & M. Hance; 12.0318 ha, Harrierville.

INTENTION TO RENEW MINING LEASE

No. 887-1; J. E. Radcliffe and G. I. Guy; 7.224 ha, Parish of Budgerum East.

MINING LEASES RENEWED

No. 849-1; K. G. Keller; 20 ha, Parish of Albacutya.

No. 1411; Martin Exploration Pty Ltd; 10 ha, Parish of Tongio-Munjie West.

MINING LEASE CANCELLED

No. 1153; D. R. Brown & B. W. Cuffley; 154.32 ha, Yackandandah.

MINING LEASE COVENANT VARIED

No. 315; Covenant 7 varied.

MINING LEASES TRANSFERRED

Nos. 1454 & 1455; From R. C. Davidson to Chenar Pty Ltd.

INTENTION TO GRANT DEVELOPMENT  
LEASES

No. 116; CRA Exploration Pty Ltd; 259 ha, Parish of Ballarat and Buninyong.

Nos. 480 and 482; Interactive Process Services Pty Ltd, C. William & Associates and A. D. Garrett; 199.725 and 135.199 ha, Parish of Maldon, Muckleford and Tarrengower.

No. 812; J. Wilcox, R. Wright and J. Balfour; 12.5 ha, Parish of Stanley.

APPLICATION FOR DEVELOPMENT  
LEASE REFUSED

No. 1057; N. T. Motton; 55.96 ha, Smythesdale.

APPLICATIONS FOR DEVELOPMENT  
LEASE DECLARED ABANDONED

No. 269; Muratio Pty Ltd; 22 ha, Parish of Moorabool West.

No. 548; G. M. Proctor, T. G. Kordell, N. M. Higgins and R. H. Kirby; 104.8 ha, Parish of Boola Boloke.

No. 933; R. A. Farquhar & R. G. Pyle; 15 ha, Parish of Mullindolingong.

APPLICATION FOR DEVELOPMENT  
LEASE TRANSFERRED

No. 225; From Hardrock Exploration Pty Ltd to Western Mining Corporation Ltd.

INTENTION TO GRANT PROSPECTING  
AREA LICENCES

No. 522; Cathgold Pty Ltd; 27 ha, Parish of Craigie.

No. 573; L. Hopcroft & H. Walker; 213 ha, Parish of Borung.

No. 678; Centaur Mining and Exploration Ltd; 150 ha, Parish of Ararat and Burrumbeep.

Nos. 770 and 771; A. R. Fraser; 13.8 and 120 ha, Parish of Moora.

PROSPECTING AREA LICENCE GRANTED

No. 99; Golden Phoenix NL; 42 ha, Parish of Neilborough.

APPLICATION FOR PROSPECTING AREA  
LICENCE REFUSED

No. 783; Vicgold NL; 250 ha, Parish of Argyle.

APPLICATIONS FOR PROSPECTING AREA  
LICENCE DECLARED ABANDONED

No. 423; Mopoke Creek Gold Mining Co NL; 123 ha, Parish of Tarengower, Muckleford and Stranways.

No. 670; R. A. Farquhar & R. G. Pyle; 15 ha, Parish of Mullindolingong.

APPLICATION TO RENEW A  
PROSPECTING AREA LICENCE  
WITHDRAWN

No. 27-2; Western Mining Corporation Ltd & Southern Continental Mining Ltd; 47.2 ha, Parish of Morri Morri.

PROSPECTING AREA LICENCES  
CANCELLED

No. 40; Southern Continental Mining Ltd; 53.6 ha, Elphinstone, Drummond and Edgecombe.

Nos. 159 and 160; Pyrenees Mining Co Pty Ltd; 211 and 182 ha, Kingower.

No. 161; Pyrenees Mining Co Pty Ltd; 171 ha, Brenanah.

No. 190; Pyrenees Mining Co Pty Ltd; 232 ha, Tchirree.

No. 192; Pyrenees Mining Co Pty Ltd; 141 ha, Painswick.

No. 252; Goldsearch Ltd, 124 ha, Maryborough.

No. 384; Alexander Lehman Pty Ltd; 130 ha, Moyreisk and Natteyallock.

Nos. 513 and 516; Alexander Lehman Pty Ltd; 223 and 223 ha, Dalyenong and Natteyallock.

Nos. 514 and 515; Alexander Lehman Pty Ltd; 157 and 151 ha, Dalyenong.

No. 555; Alexander Lehman Pty Ltd; 226 ha, Rathscar.

WATER RIGHT CANCELLED

No. 1244; M. Hance; Harrierville.

1298 G 21 31 May 1989

LEASED AREA LICENCE GRANTED

No. 1; K. W. Brice; 1 ha, Parish of Sandhurst.

INTENTION TO GRANT MINING AREA LICENCE

No. 32; Village Mines NL; 13 ha, Parish of Tonjio-Munjie West.

INTENTION TO GRANT WATER LINE LICENCE

No. 7; Perseverance Mining Pty Ltd; Parish of Waranga.

TAILINGS REMOVAL LICENCE GRANTED

No. 5430; Western Mining Corporation Ltd; Parish of Stawell.

TAILINGS REMOVAL LICENCE CONDITION VARIED

No. 5224; Condition 10 varied.

APPLICATION FOR TAILINGS TREATMENT LICENCE WITHDRAWN

No. 493; Goldsearch Ltd; 6 ha, Parish of Dunolly.

APPLICATION FOR TAILINGS TREATMENT LICENCE DECLARED ABANDONED

No. 497; Centfield Mining Pty Ltd; Shire of Bright.

INTENTION TO GRANT EXPLORATION LICENCES

No. 2020; N. T. Motton; 31 km<sup>2</sup>, Creswick and Blingaree.

No. 2047; Village Mines NL; 36.25 km<sup>2</sup>, Benambra.

No. 2080; Triad Minerals NL; 27 km<sup>2</sup>, Albury.

No. 2410; Goldrill Pty Ltd; 84 km<sup>2</sup>, Shire of Omeo.

No. 2411; Thirty Third Shako Pty Ltd; 5.75 km<sup>2</sup>, Alexandra.

No. 2421; New Holland Mining NL; 4 km<sup>2</sup>, Shire of Waranga.

No. 2432; Bendigo Mining NL; 51.75 km<sup>2</sup>, Bendigo.

No. 2435; R. Brooks & W. Brooks; 187 km<sup>2</sup>, Bet Bet and Kara Kara.

Nos. 2436 and 2446; Fidunu Pty Ltd; 500 km<sup>2</sup>, & 162 km<sup>2</sup>, Shire of Kaniva and Lowan.

No. 2437; CRA Exploration Pty Ltd; 49.5 km<sup>2</sup>, Waranga.

No. 2441; Tasrock Resources Pty Ltd and Australian Gold Development NL; 26 km<sup>2</sup>, Tambo.

No. 2445; CRA Exploration Pty Ltd; 151 km<sup>2</sup>, Wartook.

No. 2447; Fidunu Pty Ltd; 318 km<sup>2</sup>, Shire of Kowree.

No. 2470; Orion Resources NL & B. R., D. R. & I. J. McLean; 148 km<sup>2</sup>, Healesville and Upper Yarra.

Victoria Government Gazette

EXPLORATION LICENCES GRANTED

No. 2048; Village Mines NL; 78.25 km<sup>2</sup>, Bendigo.

No. 2060; Village Mines NL; 50 km<sup>2</sup>, Shire of Orbost.

No. 2074; Noble Resources NL; 71.5 km<sup>2</sup>, Shire of Buninyong.

No. 2183; BHP Gold Mines Ltd; 37.75 km<sup>2</sup>, Shire of Bet Bet.

No. 2184; BHP Gold Mines Ltd; 42.75 km<sup>2</sup>, Dunolly.

No. 2267; Oroya Gold EMI Pty Ltd; 0.5 km<sup>2</sup>, Shire of Bet Bet.

No. 2289; Phoenix Resources NL; 6.5 km<sup>2</sup>, Shire of Upper Murray.

No. 2303; Eurast Mineral Exploration Ltd; 498 km<sup>2</sup>, Lowan.

No. 2340; CRA Exploration Pty Ltd; 411.25 km<sup>2</sup>, Shire of Kerang.

No. 2341; CRA Exploration Pty Ltd; 425.5 km<sup>2</sup>, Kara Kara.

No. 2342; CRA Exploration Pty Ltd; 478 km<sup>2</sup>, Shire of Donald.

No. 2345; Centaur Mining & Exploration Ltd; 49.75 km<sup>2</sup>, Stawell.

APPLICATIONS FOR EXPLORATION LICENCE WITHDRAWN

No. 1912; Western Mining Corporation Ltd; 65 km<sup>2</sup>, Clunes.

No. 2223; Warren Jay Holdings Pty Ltd; 182 km<sup>2</sup>, Alexandra.

No. 2448; Oroya Gold EMI Pty Ltd; 13 km<sup>2</sup>, Shire of Bet Bet.

APPLICATION FOR EXPLORATION LICENCE REFUSED

No. 2124; Australian Gold Development NL; 298.75 km<sup>2</sup>, Newstead.

INTENTION TO EXTEND EXPLORATION LICENCES

No. 1524-2; Aymleg Pty Ltd; 196 km<sup>2</sup>, Matlock and Maffra.

No. 1640-2; B. R. & D. R. McLean and Continental Resources NL; 74 km<sup>2</sup>, Kara Kara & Gladstone.

No. 1968-1; P. J. Woods; 189 km<sup>2</sup>, Myrtleford.

No. 1970-1; P. J. Woods; 108.5 km<sup>2</sup>, Tallangatta and Yackandandah.

No. 1988-1; Aberfoyle Resources Ltd and Balmoral Resources NL; 242 km<sup>2</sup>, Warracknabeal.

No. 2114-1; P. J. Woods; 100 km<sup>2</sup>, Omeo and Bairnsdale.

No. 2170-1; A. M. Rigg; 242 km<sup>2</sup>, Benalla, Violet Town, Goulburn and Shepparton.

EXPLORATION LICENCES EXTENDED

No. 1498-2; Takadori Gold (Australia) Pty Ltd; 41.25 km<sup>2</sup>, Yea.

*Victoria Government Gazette*

No. 1510-2; P. S. & G. F. Forwood Pty Ltd; 35.25 km<sup>2</sup>, Moyston.

No. 1658-1; BHP Minerals Ltd; 121.25 km<sup>2</sup>, Murrindal and Orbost.

No. 1675-1; T. F. Croft; 41 km<sup>2</sup>, Shire of Bairnsdale.

No. 1931-1; Aberfoyle Resources Ltd & Sandhurst Mining NL; 312 km<sup>2</sup>, Shire of Dunmunkle and Wimmera.

**APPLICATION FOR EXTENSION OF EXPLORATION LICENCE REFUSED**

No. 1672-1; T. F. Croft; 193 km<sup>2</sup>, Upper Yarra.

The above area will become available again for exploration licence on 20 November 1989.

**AREA RELINQUISHED FROM EXPLORATION LICENCE**

No. 1778; 49.25 km<sup>2</sup>, Beaufort.

The above relinquished area will become available again for exploration licence on 20 November 1989.

**EXPLORATION LICENCE TRANSFERRED**

No. 1825; From Kinglake Resources Pty Ltd, to Ballarat Goldfields Ltd.

**EXTRACTIVE INDUSTRY LICENCES GRANTED**

No. 1273; Boral Resources (Vic.) Pty Ltd; 11.26 ha, Parish of Coimadai.

No. 1280; G. W. Rudolph and Co. Pty Ltd; 52 ha, Parish of Timboon.

No. 1288; J. H. Bramley; 9.59 ha, Parish of Koroit.

Nos 1366 and 1367; Union Rd Quarries Pty Ltd; 1.54 and 2 ha, Parish of Langwarrin.

No. 1378; Seymour Quarries Pty Ltd; Parish of Seymour.

**APPLICATION FOR EXTRACTIVE INDUSTRY LICENCE REFUSED**

No. 1421; A. E. Prossor; Parish of Ulupna.

**EXTRACTIVE INDUSTRY LICENCE RENEWED**

No. 219-1; Amatek Ltd; Parish of Mordialloc.

**APPLICATION FOR RENEWAL OF EXTRACTIVE INDUSTRY LICENCE REFUSED**

No. 779-2; N. F. Moon; Parish of Diggora.

**EXTRACTIVE INDUSTRY LICENCE EXPIRED**

No. 779-1; N. F. Moon; Parish of Diggora.

**APPLICATION FOR EXTRACTIVE INDUSTRY LEASE ABANDONED**

No. 369; R. F. Kerr Quarries Pty Ltd; Parish of Bunyip.

**ADDENDUM**

The notice appearing in the *Victoria Government Gazette*, dated 17 May 1989 relating

G 21 31 May 1989 1299

to application No. 298-1 under the heading "Extractive Industry Licences Renewed" should have appeared under the heading "Extractive Industry Leases Renewed".

**MINISTERIAL ORDER PURSUANT TO SECTION 79 (c)**

I hereby declare the 80 ha of Mining Lease No. 1865 located within Cobberas-Tingaringy National Park void.

D. R. WHITE

Minister for Industry, Technology and Resources

*Upper Yarra Valley and Dandenong Ranges Authority Act 1976*

**UPPER YARRA VALLEY AND DANDENONG RANGES REGIONAL STRATEGY PLAN**

**Notice of Amendment**

**Amendment No. 27**

In pursuance of the powers conferred by the *Upper Yarra Valley and Dandenong Ranges Authority Act 1976*, the Administrator in Council on 30 May 1989 amended the abovementioned Regional Strategy Plan.

The amendment comes into operation on the date this Notice is published in the *Government Gazette*.

The amendment alters Action A3.204 to allow the construction of a house on Allotment 2 LP 58509 Hazel Crescent, Healesville, Shire of Healesville.

A copy of the amendment documents may be inspected free of charge, during office hours, at the office of the Ministry for Planning and Environment, The Olderfleet Buildings, 477 Collins Street, Melbourne, and at the offices of the Authority, 7-9 John Street, Lilydale.

GEOFF CODE

Manager

Planning Co-ordination Branch

*Subordinate Legislation Act 1962*

**SUBDIVISION (BODY CORPORATE) REGULATIONS 1989**

In accordance with the provisions of the *Subordinate Legislation Act 1962*, notice is given of the proposal to make the abovementioned Regulations.

A Regulatory Impact Statement has been prepared in respect of the proposed Regulations.

The Regulations will enable the *Subdivision Act 1988* to be brought into force and will, together with the Act:

Prescribe the duties and powers of Bodies Corporate established under the *Strata Titles Act 1967* and the *Subdivision Act 1988*.

1300 G 21 31 May 1989

Prescribe procedures for the establishment, administration and conduct of meetings by Bodies Corporate.

Establish the duties of owners and occupiers of property that is affected by Body Corporate.

Copies of the RIS may be obtained from Diane Cockroft, Ministry for Planning and Environment, 3rd Floor, 477 Collins Street, Melbourne 3000 (Telephone: (03) 628 5388).

Public comments are invited on the RIS and the proposed Regulations. Written submission should be forwarded to the above address by no later than Monday, 26 June 1989.

J. SHIELDS

Assistant Director  
Policy and Projects

Ministry for Planning and Environment

*Planning and Environment Act 1987*

ALL PLANNING SCHEMES IN VICTORIA

Notice of Approval of Amendment

Amendment S2

The Minister for Planning and Environment has approved Amendment S2 to all Planning Schemes in Victoria.

The amendment comes into operation on the date this notice is published in the *Government Gazette*.

The amendment sets out planning policy for housing development in the State section of all planning schemes in Victoria. To assist in implementation of policy, the Residential Development Provisions (RDPs) are incorporated into schemes by reference. However, the RDPs will have no effect unless the local section of any scheme is amended to specify those provisions which are to apply, and the areas to which they will apply.

A copy of the amendment can be inspected, free of charge, during office hours at the Ministry for Planning and Environment, Ground Floor, The Olderfleet Buildings, 477 Collins Street, Melbourne and at each municipal office in Victoria.

GEOFF COOK

Assistant Manager  
Planning Co-ordination Branch

*Planning and Environment Act 1987*

METROPOLITAN REGION PLANNING  
SCHEMES

Notice of Approval of Amendment

Amendment RL37, Part I

The Minister for Planning and Environment has approved this amendment which affects the Regional Section of the Metropolitan Region Planning Schemes and the Local Section of the Knox Planning Scheme.

*Victoria Government Gazette*

The amendment comes into effect on the date this notice is published in the *Government Gazette*.

The amendment modifies the schemes as follows—

A. REGIONAL SECTION

A specific site control is removed from Lots 2 and 3 LP 55714 High Street Road, Wantirna South.

A specific site control is introduced on Lot 2 LP 72536 Dorset Road, Bayswater.

The table of uses is revised and all new buildings and works are made subject to permit in the Knox Rural Residential Zone.

Conditions for the establishment of a mechanical car wash are established for the following Knox Zones—Commercial Drive-In, Commercial General, Commercial Industrial, Service, Garden Industrial, Residential Development, General Industrial and Light Industrial.

B. LOCAL SECTION

Lot 2 LP 72536 Dorset Road, Bayswater, is included in a Knox Garden Industrial Zone.

Land on the north side of Burwood Highway and east of Mossfield Avenue, Ferntree Gully, is included in a Knox Commercial Local Zone.

A copy of the amendment can be inspected, free of charge, during office hours at the Ministry for Planning and Environment, Ground Floor, The Olderfleet Buildings, 477 Collins Street, Melbourne, the City of Knox, Civic Centre, 511 Burwood Highway, Knoxfield, and a copy of the Regional Section at each municipal office in the Metropolitan Region.

GEOFF COOK

Assistant Manager

Planning Co-ordination Branch

*Planning and Environment Act 1987*

METROPOLITAN REGION PLANNING  
SCHEMES

Notice of Approval of Amendment

Amendment R21

The Minister for Planning and Environment has approved Amendment R21 to the Metropolitan Region Planning Schemes.

The amendment comes into operation on the date this notice is published in the *Government Gazette*.

The amendment includes new setback requirements for development in industrial zones in the City of South Melbourne.

A copy of the amendment can be inspected, free of charge, during office hours at the Ministry for Planning and Environment, Ground Floor,



*Victoria Government Gazette*

The Olderfleet Buildings, 477 Collins Street, Melbourne, and at each municipal office in the Metropolitan Region.

GEOFF COOK  
Assistant Manager  
Planning Co-ordination Branch

---

*Planning and Environment Act 1987*

**METROPOLITAN REGION PLANNING  
SCHEMES**

**Notice of Approval of Amendment  
Amendment R35**

The Minister for Planning and Environment has approved Amendment R35 to the Metropolitan Region Planning Schemes.

The amendment comes into operation on the date this notice is published in the *Government Gazette*.

The amendment makes swimming pools and external spas as-of-right provided they comply with specified setback requirements in the Berwick Residential Normal Density, Berwick Residential Low Density, Berwick Residential—Berwick Township Zones.

A copy of the amendment can be inspected, free of charge, during office hours at the Ministry for Planning and Environment, Ground Floor, The Olderfleet Buildings, 477 Collins Street, Melbourne, and First Floor, 33-39 High Street, Cranbourne, and at each municipal office in the Metropolitan Region.

GEOFF COOK  
Assistant Manager  
Planning Co-ordination Branch

---

*Planning and Environment Act 1987*

**MELBOURNE PLANNING SCHEME**

**Notice of Amendment to Planning Scheme  
Amendment L18**

The Minister for Planning and Environment has prepared Amendment L18 to the Melbourne Planning Scheme.

The amendment includes the former Melbourne German Club at 7 Alfred Place, Melbourne, as a Notable Building in the Scheme.

The amendment can be inspected at the Ministry for Planning and Environment, Ground Floor, The Olderfleet Buildings, 477 Collins Street, Melbourne, and at the offices of the City of Melbourne, Council House, 200 Little Collins Street, Melbourne.

Submissions about the amendment must be sent to the Minister for Planning and Environment, Attention: Planning Co-ordination Branch, P.O. Box 2240T, Melbourne, 3001 by 3 July 1989.

GEOFF COOK  
Assistant Manager  
Planning Co-ordination Branch

G 21 31 May 1989 1301

*Planning and Environment Act 1987*  
**METROPOLITAN REGION PLANNING  
SCHEMES**

**Notice of Approval of Amendment  
Amendment RL44**

The Minister for Planning and Environment has approved Amendment RL44 to the Metropolitan Region Planning Schemes. The amendment includes modifications to the Regional Section of all Planning Schemes in the Metropolitan Region and Local Section of the Werribee Planning Scheme.

The amendment comes into operation on the date this notice is published in the *Government Gazette*.

The amendment introduces a new zone, called the Werribee Harbour Zone, for land and water situated at the southern end, and on the eastern side, of Duncans Road, Werribee South. The land includes the crown foreshore reserve, the adjacent area of Port Phillip Bay and an area of agricultural land. The provisions of the zone allow for the development of a 300 berth marina with associated onshore facilities and tourist development.

A copy of the amendment can be inspected, free of charge, during office hours at the Ministry for Planning and Environment, Ground Floor, The Olderfleet Buildings, 477 Collins Street, Melbourne; the Ministry for Planning and Environment, Western Region Office, 5th Floor, 235 Queen Street, Melbourne; City of Werribee, Civic Centre, Princes Highway, Werribee and the amendment to the Regional Section at each municipal office in the Metropolitan Region.

GEOFF COOK  
Assistant Manager  
Planning Co-ordination Branch

---

**Department of Property and Services  
SALE OF CROWN PROPERTY BY PUBLIC  
AUCTION**

Reference No. GL 10300

On Saturday, 1 July 1989 at 11.00 a.m. on site.

**Property Address:** 24 Sheehan Crescent, Shepparton.

**Crown Description:** Crown Allotment 12C, Parish of Shepparton County of Moira.

**Area:** 571m<sup>2</sup>

**Terms of Sale:** 10% deposit balance 60 days

**Officer Co-ordinating Sale:** Mr M. Christofas, Property Consultant, Government Land Bureau, Department of Property and Services.

**Selling Agent:** D. J. O'Shea and Co. Pty. Ltd., 193A Corio Street, Shepparton, Telephone (058) 21 8388

R. W. WALSH  
Minister for Property and Services

## Private Agents Act 1966

## NOTICE OF RECEIPT OF APPLICATIONS FOR LICENCES

Any objections to the applications below should be in accordance with the *Private Agents Act 1966 s.12* and *Private Agents Regulations 1988, reg. 16.*

Full Name of Applicant/Nominee	Residential Address	Name of Firm or Corporation	Address for Registration	*Licence Type	Hearing Date and Court
Cain, Matthew John	44 Danielle Cres, Heathmont		44 Danielle Cres, Heathmont	P	24.6.89 Ringwood
Sheen, Michael John	22 McGregor Cres, Shepparton	Asdic Security Industries Pty Ltd	5/47 Vaughn St, Shepparton	W	26.6.89
Moylan, Brian John	11 McCubbin Dve, Shepparton	Metropolitan Security Services	11 McCubbin Dve, Shepparton	"	" Shepparton
Kingsley, Phillip John	33 Elizabeth St, Traralgon		15 Bayley Dve, Traralgon	"	16.6.89 Traralgon
Czaj, Marek	2 Bellara St, Vermont		2 Bellara St, Vermont	P	3.7.89 Ringwood
Spivey, Robert Allan	924 15th St, Mildura		390 St Kilda Rd, Melbourne	W	14.6.89 Mildura
Austin, Jennifer M	33 Olympiad Cres, Box Hill North	AMG Security Services	33 Olympiad Cres, Box Hill North	G	26.6.89
Austin, Shane C	33 Olympiad Cres, Box Hill North	AMG Security Services	33 Olympiad Cres, Box Hill North	G	22.6.89 Box Hill
Crino, Walter Fabian	16 Rhodes St, Springvale	A.S.C. Security Services	16 Colchester Dr, East Doncaster	W	26.6.89
Dounias, John	65 Theodore Ave, Noble Park	Accomplished Investigations and Security Services Pty Ltd	15 Ceylon St, Nunawading	"	25.6.89 Box Hill
Ladd, Jeanette Elizabeth	4 Hawkins Rd, Montrose	T & J Insurance Assessors	4 Hawkins Rd, Montrose	IA	19.6.89 Lilydale
Payne, Terrence Charles	" " "	" "	" " "	"	"
Beard, Jonathan Frederick Andrew	31 Yertchuk Ave, Ashwood		2 Esper Ave, South Oakleigh	IA	20.6.89 Oakleigh
" "	" " "		" " "	P	"
" "	" " "		" " "	G	"
" "	" " "		" " "	CS	"
Sposato, Giuseppe	29 Jeanine Cres, Fawkner	Joel Special Investigations Group	410 Bell St, Pascoe Vale	IA	19.6.89 Moonee Ponds
" "	" " "		" " "	P	"
Bordin, Leo John	129 Parar Rd, Airport West		" " "	IA	"
Shaw, Jennifer A	10 Bryden Dve, Ferntree Gully	Mansfield Security Service	10 Bryden Dve, Ferntree Gully	G	1.6.89 Box Hill
Shaw, Christopher J	" " "	" "	" " "	P	"
" "	" " "	" "	" " "	GA	"
" "	" " "	" "	" " "	P	"
Basanis, Giuseppe P	34 Stonehaven Dve, Thomastown	ASC Security Services	16 Colchester Dve, East Doncaster	W	20.6.89 Box Hill
Bradford, Gayle E	399 Dorset Rd, Croydon		6 Telopea Crt, North Frankston	W	13.6.89 Frankston
Lochhead, Alexander Robert	Cowra Ave, Mildura		390 St Kilda Rd, Melbourne	"	14.6.89
Creighton, Kenneth Hugh	Block 488, Red Cliffs		" " "	"	20.6.89
Napoli, Domenico Gaetano	Block 264, Red Cliffs		" " "	"	" Mildura
Perez, Anthony William	3 Kalinna St, Carrum		249 Station St, Edithvale	"	20.6.89
Mizzi, Alfred	25 Barbara Ave, Dandenong North		" " "	"	" Mordialloc
Bejatovic, George Alexander	9 Bertrand St, Mulgrave	Burson Security Services Pty Ltd	13 Bainbridge Dve, Eltham	"	15.6.89
Yancov, George	1 Donald St, Laverton	" " "	" " "	"	" Heidelberg
Pettiford, Michael	26 Kaniva St, Dallas		5 Lily St, North Coburg	"	15.6.89
Michielin, John Anthony	9 Clarendon St, Coburg		32 Chevron Crt, Seaford	"	23.6.89 Broadmeadows
Birmingham, Stephen John	30 Mahen Cres, Narre Warren		30 Mahen Cres, Narre Warren	G	16.6.89 Dandenong
Morris, Russell John	25 Guinane Ave, Hoppers Crossing	R. J. Securities	25 Guinane Ave, Hoppers Crossing	"	21.6.89
" "	" " "	" " "	" " "	IA	" Werrisbee
Harris, Leonie Joy	26 Hewitt Ave, Bendigo	Armguard	390 St Kilda Rd, Melbourne	W	23.6.89 Bendigo
Hasanovski, Erol	1/5 Adelaide St, St Albans		2/14 Gladstone St, St Albans	"	23.6.89 Sunshine
Hatzimanolis, George	177 Kingsway Dve, Lalor		177 Kingsway Dve, Lalor	IA	26.6.89
Mazzeili, Darren	37 Leamington St, Reservoir	Profile Security Services	274 Broadway, Reservoir	W	29.6.89 Preston
Peters, Peter	Lot 10, Milburn St, Keilor		3 Berrydale Crt, North Clayton	W	20.7.89 Oakleigh
Milner, David Thomas	Blk 83B, Stewart Rd, Red Cliffs		390 St. Kilda Rd, Melbourne	W	19.6.89 Mildura

\*Licence Type: CA—Commercial Agent; CS—Commercial Sub-Agent; P—Process Server; IA—Inquiry Agent; G—Guard Agent; W—Watchman

PRIVATE AGENTS—continued

Full Name of Applicant/Nominee	Residential Address	Name of Firm or Corporation	Address for Registration	Licence Type	Hearing Date and Court
Williams, Malcolm Leslie	20 Belar St. Dareton				
Graser, Enrico John	6 Ricky Cr. Bundoora		6 Ricky Cr. Bundoora	P	13.6.89
Riach, Andrew Murray	175 Collins St, Thornbury		2/32 Lower Heidelberg Rd, W Ivanhoe	W	Heidelberg 15.6.89
Brehaut, Stephen John	10 Albert St. Myrtleford	Ovens Valley Security Service	3 Anderson St. Bright and 10 Albert St. Myrtleford	G	16.6.89 Myrtleford
Buna, Michael	63 Jensen Rd, East Preston	Nationwide Alef Security Services	167 McKinnon Rd, McKinnon	W	29.6.89 Oakleigh
Reid, Mary Jane	4 Rudolph St, Hoppers Crossing	" "	" " " "	"	"
Karas, Bill	2/174 George St, Fitzroy	" "	" " " "	"	"
Walker, Ewen Gordon	11 Dallas Cres, Watsonia	" "	" " " "	"	20.7.89
Boyd, Desmond John	18 Lark St, Altona	Ace Security Pty Ltd	18 Lark St, Altona	G	3.7.89
Lo Piccolo, Robert	39 Rodney Ave, Coburg North		39 Rodney Ave, Coburg North	"	Williamstown 16.6.89
Lowry, Kerry Lorraine	6/22 Norfolk St, Bendigo	Armaguard	390 St Kilda Rd, Melbourne	W	Broadmeadows 23.6.89 Bendigo
Collins, Robert John	9 Galway St, Castlemaine	" "	" " " "	"	"
Upston, Kathryn Ann	8 Third Ave, Chelsea Heights	Nationwide Alef Security Services	167 McKinnon Rd, McKinnon	W	27.6.89 Oakleigh
Messina, Bruno	5 Skewes St, Braybrook	" "	" " " "	"	"
Ellis, Noel Francis	29 Canterbury Rd, Heathmont	" "	" " " "	"	28.6.89
Davies, Graham Terrence	4 Margate St, Beaumaris	" "	" " " "	"	"
Gemmell, Andrew Christopher	10 Morlyn Dve, Mt. Martha	" "	10 Morlyn Dve, Mt. Martha	P	21.6.89 Mornington
Smithson, Terrence Richard	14 Palpera Tce, Greensborough	" "	14 Palpera Tce, Greensborough	IA	13.6.89 Heidelberg
Moate, Richard Dale	4/64 Olympic Ave, Shepparton	Metropolitan Security Services	634 Graham St, Port Melbourne	W	26.6.89 Shepparton
Daniels, Mark Christopher	Unit 1/20 Don St, Reservoir	" "	Unit 1/20 Don St, Reservoir	IA	19.6.89 Preston
Boyd, Timothy	3 Langold Cr, Noble Park	" "	4 Formosa Cr, Narre Warren	W	23.6.89 Dandenong

\*Licence Type: CA—Commercial Agent; CS—Commercial Sub-Agent; P—Process Server; IA—Inquiry Agent; G—Guard Agent; W—Watchman

STATE TENDER BOARD  
CONTRACTS ACCEPTED  
Amendments

Schedule Number	Item Number	New Rate	Effective Date
<i>Chemicals, Agricultural etc.</i>			
1/03	66	\$ 12.80	7.6.89
<i>Electrical Goods</i>			
1/05	14}	Eveready	26.5.89
	15}	Price List	
		26.3.89	
		Less 26-5%	
<i>Motor Spirit, Kerosene, Fuel Oils and Lubricants</i>			
1/53B	18	0.5669	25.5.89
<i>Typewriters, Electronic</i>			
1/77	1-3	*	31.5.89
* Delete: Adler Business Machines Pty. Ltd. Add: TA Triumph Adler (Australia) Pty. Ltd. (inc. in N.S.W.).			
<i>Provisions/Groceries</i>			
2/01A	1	Arnott Price List 5.6.89	5.6.89

J. M. PAWSON  
Secretary to the Tender Board

CONTRACTS ACCEPTED—Series 88/89  
Victoria Police

T. 130 *Transport Division:*  
Construction and supply of a Mobile Field Kitchen  
\$32 650.00—Australian Caravans.  
T. 131—*Transport Division*  
Construction and supply of a Prison Van  
\$95 400.00—Chariot (Australia) Pty. Ltd.  
P. J. HALE  
Supply Manager

Police Regulation Act 1958  
Section 122

SALE OF FORFEITED PROPERTY  
An owner is required for an unregistered Honda 400 c.c. motor cycle, engine number CB400FE1034147, which came into possession of Police on 4 August 1988.

In accordance with an order issued by the Frankston Magistrates' Court on 15 November 1988, the vehicle will be sold by public auction at 10 a.m. on 18 July 1989, at Chelsea Police Station, 2 The Strand, Chelsea.

K. GLARE  
Chief Commissioner

1304 G 21 31 May 1989

**VICTORIAN GRAPHIC ARTS AWARD  
Superannuation—Notice of Proposed Award  
Variation**

Notice is hereby given that the Printing and Kindred Industries Union (Victorian Branch) has applied for the decision of Mr Commissioner Donaldson of the Australian Industrial Relations Commission in relation to the Printing Industry Superannuation Award 1988 (Print H 6898) to flow on as a common rule to the Graphic Arts Award by providing superannuation as a condition of employment.

The application provides for contributions on behalf of employees to a superannuation scheme established in terms consistent with the requirements of the Occupational Superannuation Commission and as detailed in the Industrial Relations Commission of Victoria State Wage Case Decision of 10 April 1987.

Any employer or other person interested in this matter may obtain particulars of the application from the Registrar, Industrial Relations Commission of Victoria, Level 18, Nauru House, 80 Collins Street, Melbourne 3000, Telephone: (03) 650 4431.

The Graphic Arts Board will meet on Friday, 30 June 1989 at 10.00 a.m. in Hearing Room No. 8, Level 17, Nauru House, 30 Collins Street, Melbourne 3000, At that meeting the Board will consider varying the Graphic Arts Award in the terms of the application. Any employer with a relevant interest in this matter is at liberty to apply to make representations to the Board at its 30 June 1989 meeting or to apply for exemption from the proposed Award variation.

**VICTORIAN COUNTRY PRINTERS  
AWARD**

**Superannuation—Notice of Proposed Award  
Variation**

Notice is hereby given that the Printing and Kindred Industries Union (Victorian Branch) has applied for the Decision of Mr Commissioner Donaldson of the Australian Industrial Relations Commission in relation to the Printing Industry Superannuation Award 1988 (Print H 6898) to flow on as a common rule to the Country Printers Award by providing superannuation as a condition of employment.

The application provides for contributions on behalf of employees to a superannuation scheme established in terms consistent with the requirements of the Occupational Superannuation Commission and as detailed in the Industrial Relations Commission of Victoria State Wage Case Decision of 10 April 1987.

Any employer or other person interested in this matter may obtain particulars of the application from the Registrar, Industrial

*Victoria Government Gazette*

Relations Commission of Victoria, Level 18, Nauru House, 80 Collins Street, Melbourne 3000, Telephone: (03) 650 4431.

The Country Printers Board will meet on Friday, 30 June 1989 at 10.00 a.m. in Hearing Room No. 8, Level 17, Nauru House, 30 Collins Street, Melbourne 3000. At that meeting the Board will consider varying the Country Printers Award in the terms of the application. Any employer with a relevant interest in this matter is at liberty to apply to make representations to the Board at its 30 June 1989 meeting or to apply for exemption from the proposed Award variation.

*Education Act 1958*

**NOTICE OF THE MAKING OF ORDERS  
UNDER SECTION 13 (4) OF THE ACT**

Under section 13 of the *Education Act 1958* I hereby give notice that Orders of the Governor in Council were made on 23 May 1989 under sub-section (4) of the said Act amending certain provisions relating to the school councils listed below:

1503 Tooradin Primary School Council  
2048 Brighton Beach Primary School Council  
4874 Pinewood Primary School Council  
5257 Langwarrin Park Primary School Council  
5258 Taylors Lakes Primary School Council  
5280 Clifton Springs Primary School Council  
7540 Ballarat High School Council.

J. E. KIRNER  
Minister for Education

*Education Act 1958*

**NOTICE OF THE MAKING OF AN ORDER  
UNDER SECTIONS 13 (1), (4) AND (5) OF  
THE ACT**

Under section 13 of the *Education Act 1958* I hereby give notice that an Order of the Governor in Council was made on 23 May 1989 under sub-section (1) constituting a council for:

Orchard Grove Primary School  
and under sub-section (4) dissolving the school council for:

Blackburn South Primary School, Killoura Primary School, Mirrabooka Primary School and Warrawong Primary School Council  
and under sub-section (5) directing the disposal of any assets of the council for the:

Blackburn South Primary School, Killoura Primary School, Mirrabooka Primary School and Warrawong Primary School Council.

J. E. KIRNER  
Minister for Education

Victoria Government Gazette

*Co-operation Act 1981*

WESTERN COMMUNITY SAVINGS  
CREDIT UNION CO-OPERATIVE LIMITED

Notice is hereby given that I have this day registered the dissolution of the abovenamed society and cancelled its registration under the abovenamed Act.

Dated at Melbourne 15 May 1989

A. M. SARFIELD

Deputy Registrar of Co-operative Societies

*Co-operative Housing Societies Act 1958*

PROPOSED CO-OPERATIVE HOUSING  
SOCIETIES (GENERAL) (AMENDMENT)  
REGULATIONS 1989

It is proposed that the Co-operative Housing Societies (General) (Amendment) Regulations 1989 be made to ensure that the Treasurer's aggregate liability with respect to indemnity agreements, as determined by statute, is not exceeded. This will encourage financial institutions to maintain loans to co-operative housing societies in response to the increased demand on housing finance.

A Regulatory Impact Statement has been prepared and this concludes that the proposed regulations are the most appropriate and efficient means of ensuring that the Treasurer's aggregate liability is not exceeded.

Comments and submissions are invited from the public and will be received up to 21 days from the publication of this notice.

Copies of the Regulatory Impact Statement are available from Maria Sandbach, Legal Officer, Registry of Co-operatives and Societies, Corporate Affairs, 9th Floor, 471 Little Bourke Street, Melbourne, Telephone 603 4637.

E. PROUST  
Secretary

Attorney-General's Department Victoria

*Co-operation Act 1981*

CHELTENHAM SECONDARY COLLEGE  
CO-OPERATIVE LIMITED  
1ST OAKWOOD PARK BOY SCOUT  
CO-OPERATIVE LIMITED

Notice is hereby given in pursuance of section 192 (8) of the *Co-operation Act 1981* and section 459 (2) of the Companies (Victoria) Code, that, at the expiration of three months from the date hereof, the names of the aforementioned societies will, unless cause is shown to the contrary, be struck off the register and the societies will be dissolved.

Dated at Melbourne 15 May 1989

L. G. HOPKINS

Deputy Registrar of Co-operative Societies

G 21 31 May 1989 1305

*Subordinate Legislation Act 1962*

ROAD SAFETY (VEHICLES)  
(AMENDMENT No. 2) REGULATIONS 1989

ROAD SAFETY (PROCEDURES)  
(AMENDMENT No. 3) REGULATIONS 1989

Suspension of Driver Licence or Vehicle  
Registration where Traffic and Parking Fines  
Remain Outstanding

I, James Harley Kennan, Minister for Transport, give notice that after consideration of the submissions and comments received in response to the Regulatory Impact Statement issued in relation to the proposed Regulations I intend to proceed with the making of the proposed regulations in amended form. The Road Safety (Vehicles) (Amendment No. 2) Regulations will now provide for suspension of vehicle registration only where the registered owner who has incurred the fine is a body corporate.

J. H. KENNAN  
Minister for Transport

*Co-operative Housing Societies Act 1958*

NOTICE OF DISSOLUTION OF SOCIETIES

A.N.A. CO-OPERATIVE HOUSING  
SOCIETY (No. 11) LIMITED

A.N.A. CO-OPERATIVE HOUSING  
SOCIETY (No. 13) LIMITED

COBURG No. 7 CO-OPERATIVE HOUSING  
SOCIETY LIMITED

COMMERCIAL No. 2 CO-OPERATIVE  
HOUSING SOCIETY LIMITED

CORIO AND MOORPANYAL (No. 6) CO-  
OPERATIVE HOUSING SOCIETY LIMITED

CORIO AND MOORPANYAL (No. 9) CO-  
OPERATIVE HOUSING SOCIETY LIMITED

DEAKIN No. 2 CO-OPERATIVE HOUSING  
SOCIETY LIMITED

FRIENDLY SOCIETIES (No. 2) CO-  
OPERATIVE HOUSING SOCIETY LIMITED

HERBERT CREMEAN CO-OPERATIVE  
HOUSING SOCIETY LIMITED

KARDINIA (No. 8) CO-OPERATIVE  
HOUSING SOCIETY LIMITED

KIAMA CO-OPERATIVE HOUSING  
SOCIETY LIMITED

KYNOCH CO-OPERATIVE HOUSING  
SOCIETY LIMITED

LAVERTON (No. 2) CO-OPERATIVE  
HOUSING SOCIETY LIMITED

LAWSON No. 3 CO-OPERATIVE HOUSING  
SOCIETY LIMITED

MAFFRA AND DISTRICT CO-OPERATIVE  
HOUSING SOCIETY LIMITED

1306 G 21 31 May 1989

M.O.A. CO-OPERATIVE HOUSING SOCIETY LIMITED  
M.O.A. No. 2 CO-OPERATIVE HOUSING SOCIETY LIMITED  
MONASH CO-OPERATIVE HOUSING SOCIETY LIMITED  
MONASH No. 2 CO-OPERATIVE HOUSING SOCIETY LIMITED  
ORBOST CO-OPERATIVE HOUSING SOCIETY LIMITED  
RESERVOIR CO-OPERATIVE HOUSING SOCIETY LIMITED  
SEPARATE TITLES CO-OPERATIVE HOUSING SOCIETY (No. 4) LIMITED  
SNOWY RIVER CO-OPERATIVE HOUSING SOCIETY LIMITED  
ST. MARY'S CO-OPERATIVE HOUSING SOCIETY LIMITED

Notice is hereby given that I have this day registered the dissolution of the abovenamed societies and cancelled their registration under the abovenamed Act.

Dated at Melbourne 28 June 1988

P. J. ROGAN  
Deputy Registrar of Co-operative Housing Societies

*Co-operative Housing Societies Act 1958*  
NOTICE OF DISSOLUTION OF SOCIETIES  
ASSOCIATED TOBACCO COMPANIES CO-OPERATIVE HOUSING SOCIETY No. 10 LIMITED  
BALLARAT A.N.A. CO-OPERATIVE HOUSING SOCIETY LIMITED  
LATROBE No. 2 CO-OPERATIVE HOUSING SOCIETY LIMITED  
ENTERPRISE CO-OPERATIVE HOUSING SOCIETY LIMITED  
GASCOR CO-OPERATIVE HOUSING SOCIETY LIMITED  
HILLSIDE (No. 1) CO-OPERATIVE HOUSING SOCIETY LIMITED  
KANGAROO FLAT (BENDIGO) No. 4 CO-OPERATIVE HOUSING SOCIETY LIMITED  
KYU CO-OPERATIVE HOUSING SOCIETY LIMITED  
MISCELLANEOUS WORKERS' CO-OPERATIVE HOUSING SOCIETY LIMITED  
NETHERLANDS AUSTRALIAN No. 1 CO-OPERATIVE HOUSING SOCIETY LIMITED  
OCEAN GROVE AND DISTRICT (No. 3) CO-OPERATIVE HOUSING SOCIETY LIMITED  
MOUNT WAVERLEY No. 2 CO-OPERATIVE HOUSING SOCIETY LIMITED

*Victoria Government Gazette*

PRAHRAN AND DISTRICT NO. 1 CO-OPERATIVE HOUSING SOCIETY LIMITED  
ROSEBUD (No. 4) CO-OPERATIVE HOUSING SOCIETY LIMITED  
SANDHURST (No. 1) CO-OPERATIVE HOUSING SOCIETY LIMITED  
S.E.C. PROJECT No. 2 CO-OPERATIVE HOUSING SOCIETY LIMITED  
SHEPPARTON AND DISTRICT (No. 10) CO-OPERATIVE HOUSING SOCIETY LIMITED  
STATAX (No. 2) CO-OPERATIVE HOUSING SOCIETY LIMITED  
WANGARATTA CO-OPERATIVE HOUSING SOCIETY No. 7 LIMITED  
WESTERN SUBURBS CO-OPERATIVE HOUSING SOCIETY LIMITED  
WORKMANS No. 2 CO-OPERATIVE HOUSING SOCIETY LIMITED

Notice is hereby given that I have this day registered the dissolution of the abovenamed societies and cancelled their registration under the abovenamed Act.

Dated at Melbourne, 29 June 1988

P. J. ROGAN  
Deputy Registrar of Co-operative Housing Societies

*Co-operation Act 1981*  
NOTICE OF DISSOLUTION OF SOCIETIES  
ALPENLAND DANCE AND ENTERTAINMENT CO-OPERATIVE SOCIETY LIMITED  
DIMBOOLA MEMORIAL HIGH SCHOOL CO-OPERATIVE LIMITED  
NEWMAN CO-OPERATIVE SOCIETY LIMITED  
MARALINGA PRIMARY SCHOOL CO-OPERATIVE LIMITED  
DANDENONG TEACHERS CENTRE CO-OPERATIVE LIMITED  
KOONUNG HIGH SCHOOL CO-OPERATIVE LIMITED  
BERWICK AND DISTRICT ARTIFICIAL BREEDING CO-OPERATIVE LIMITED  
LATROBE VALLEY MASONIC HOMES CO-OPERATIVE LIMITED

Notice is hereby given that I have this day registered the dissolution of the abovenamed societies and cancelled their registration under the abovenamed Act.

Dated at Melbourne, 22 May 1988

L. G. HOPKINS  
Deputy Registrar of Co-operative Societies

Victoria Government Gazette

VICTORIAN DAIRY INDUSTRY  
AUTHORITY

Notice Pursuant to Section 42 of the *Dairy  
Industry Act 1984*

Pursuant to the provisions of the *Dairy Industry Act 1984* the Victorian Dairy Industry Authority does, by this notice, hereby amend on the specified day the notice published in *Government Gazette*, No. G46 of 30 November 1988 as follows:

(1) From the Second Schedule of the said notice—

Under the heading Central Milk District, the following shall be deleted:

Nairn, L. J. & S. M., 6 Boston Road, Torquay.

Under the heading Northern Milk District, the following shall be deleted:

Elborough, R. J. & H. L., 9 Bishop Street, Kyabram.

(2) From the Second Schedule of the said notice—

Under the heading Central Milk District, the following shall be inserted:

Lane, J. N. & C. A., 6 Boston Road, Torquay.

Under the heading Northern Milk District, the following shall be inserted:

Barnett, G. P. & J. A., 9 Bishop Street, Kyabram.

For the purpose of this notice, the "specified day" shall be the day upon which the amendments made pursuant to this notice come into effect by virtue of section 42 (2) of the *Dairy Industry Act 1984*.

By order of the Victorian Dairy Industry Authority.

J. F. HOGAN  
Secretary

Creditors, next of kin and others having claims against the estate of any of the under-mentioned deceased persons are required to send particulars of their claims to the State Trust Corporation of Victoria, 168 Exhibition Street, Melbourne, Vic. 3000 the personal representative, on or before 1 August 1989 after which date the State Trust Corporation may convey or distribute the assets having regard only to the claims of which the State Trust Corporation then has notice:

Archer, Christina Veronica, also known as Christina Archer, formerly of 17 Finlay Street, Albert Park, late of Siesta Private Nursing Home, 11 Sheppard Street, Moorabbin, pensioner, died 22 July 1988.

Buckley, Harold Bert, late of Flat 1/7 Hatfield Court, West Footscray, pensioner, died 10 October 1988.

G 21 31 May 1989 1307

Danyluk, Adelajda, late of 47 Type Street, Richmond, pensioner, died 17 February 1989.

Day, Reginald Robert, formerly of 248 Cardigan Street, Carlton, late of Flat 13, 113 Gold Street, Collingwood, retired cleaner, died 29 January 1989.

McKenna, William Morris, late of Briery Hospital, Moore Street, Warrnambool, pensioner, died 23 July 1988.

O'Brien, John Anthony, late of 21 Alameda Avenue, Maribyrnong, retired, died 25 November 1988.

Reed, Grace Florence, formerly of Townsend Road, Whittington, late of Clyde Private Nursing Home, 21 Skene Street, Newtown, pensioner, died 23 August 1988.

Shorten, Thomas Walter, late of 3 Herbert Street, Avondale Heights, pensioner, died 1 March 1989.

Sorensen, Richard Hans, late of 4 Dorothy Avenue, Sunshine, retired, died 30 December 1988.

Taylor, Viola Blackburne, formerly of 1 Beaumont Street, Vermont, late of Strathdon Nursing Home, Forest Hill, widow, died 12 January 1989.

Melbourne, 22 May 1989

W. J. KILPATRICK

Managing Director, State Trust Corporation

Creditors, next of kin and others having claims against the estate of any of the under-mentioned deceased persons are required to send particulars of their claims to the State Trust Corporation of Victoria, 168 Exhibition Street, Melbourne, Vic. 3000 the personal representative, on or before 1 August 1989 after which date the State Trust Corporation may convey or distribute the assets having regard only to the claims of which the State Trust Corporation then has notice:

Barter, Samuel Wilfred, late of 18 Prospect Grove, Black Rock, gentleman, died 18 September 1988.

Beverley, Jane, late of Flat 64, Hedley Sutton Baptist Home, 2 Gascoyne Street, Canterbury, retired, died 12 February 1989.

Just, Marjorie Beryl, formerly of 15 Railway Avenue, Upper Ferntree Gully, late of 7 Coogee Street, Boronia, home duties, died 24 October 1988.

Melbourne, 22 May 1989

W. J. KILPATRICK

Managing Director, State Trust Corporation

Creditors, next of kin and others having claims against the estate of any of the under-mentioned deceased persons are required to send particulars of their claims to the State Trust Corporation of

1308 G 21 31 May 1989

Victoria, 168 Exhibition Street, Melbourne, Vic. 3000 the personal representative, on or before 1 August 1989 after which date the State Trust Corporation may convey or distribute the assets having regard only to the claims of which the State Trust Corporation then has notice:

Allsop, Edward Charles Joseph, late of 40 Stud Road, Bayswater, pensioner, died 4 April 1989.

Brown, Selina, late of 11A Roslyn Road, East Belmont, home duties, died 30 July 1988.

Cooper, Daisy Lillian, formerly of 47 Eastfield Road, Croydon, late of Holmwood Nursing Home, Lalor Road, Healesville, widow, died 13 July 1988.

Crosisca, Kay Lorraine, late of 90 Hotham Street, Collingwood, home duties, died 22 March 1988.

Dethridge, Mary Louisa, late of Woombye, Queensland, retired matron, died 16 December 1987.

Earle, Mura Rose, late of Flat 1, 41 Riversdale Road, Hawthorn, home duties, died 25 February 1989.

Edwards, Daisy Elizabeth, late of 86/1 Surrey Road, South Yarra, widow, died 12 April 1989.

Farrands, Constance Muriel, late of 34 Howitt Road, North Caulfield, widow, died 13 December 1988.

Gillam, Arthur Thomas, Warrnambool, retired, died 24 December 1988.

Hawkins, Ernest William, late of Abel Rest Home, 20 Laura Street, Moonee Ponds, retired, died 7 July 1988.

Griffiths, Mabel Isabella, late of 90 Rae Street, Benalla, spinster, died 17 February 1971.

Hodson, Conrad Percy, late of Flat 3, 107 Walpole Street, Kew, retired, died 8 December 1988.

Mason, Ann, late of Flat 5, 21 Kingsby Street, Elwood, home duties, died 5 or 6 November 1986.

Marklew, Helen Keast, formerly of 9 Marama Street, Merlynston, late of Colton Close Nursing Home, York Street, Glenroy, retired, died 10 March 1989.

McClellan, Hilda Violet, late of Unit 3, 2 Cameron Street, Mt. Waverley, pensioner, died 11 February 1989.

Smythe, Kathleen Winifred, late of 20 Victoria Avenue, Mitcham, widow, died 10 November 1988.

Van Den Eijnde, Anna Maria, also known as Anna Marie Vandeneynde, late of La Trobe Valley Nursing Home, 86 Wirraway Street, Moe, died 26 August 1988.

Waters, Mabel May, formerly of 1 Rosedale Road, Glen Iris, late of Unit 5, 35 Bay Road,

*Victoria Government Gazette*

Mordialloc, married woman, died 6 October 1988.

Williams, Hilda May, late of Bradley House, 558 Orrong Road, Armadale, retired, died 25 August 1988.

Wright, Jean, also known as Jane Wright, formerly of 2 Cook Street, West Brunswick, late of Werribee Private Nursing Home, corner Little Street and Central Avenue, Werribee, pensioner, died 9 September 1988.

Melbourne, 23 May 1989

W. J. KILPATRICK

Managing Director, State Trust Corporation

Creditors, next of kin and others having claims against the estate of any of the under-mentioned deceased persons are required to send particulars of their claims to the State Trust Corporation of Victoria, 168 Exhibition Street, Melbourne, Vic. 3000, the personal representative, on or before 14 August 1989 after which date the State Trust Corporation may convey or distribute the assets having regard only to the claims of which the State Trust Corporation then has notice:

Berry, Lavinia Faith, late of 4 Acacia Avenue, Upwey, widow, died 6 July 1985.

Clark, Dorothy May, formerly of Flat 2, 27 Wilson Street, Highett, late of Whitehall Special Accommodation, 1324 Nepean Highway, Mentone, widow, died 13 November 1988.

Dawson, Gordon Ernest, late of 24 Nepean Street, Watsonia, retired, died 29 November 1988.

Gilmour, Charles Gordon, late of 45 Yarraford Avenue, Alphington, retire valuer, died 13 January 1989.

Hooke, James Manson, late of 19 Delaware Street, Reservoir, retired, died 22 February 1989.

Kenzie, Alfred Ronald, late of 172 Brougham Street, Kew, retired, died 10 November 1988.

Malmberg, Ada, late of 89 Glen Street, Glenroy, widow, died 3 February 1989.

Mara, Isabella, formerly of 44 Jean Street (in the Will called 4 Jean Street, Cheltenham), late of Keswick Nursing Home, 42 Mentone Parade, Mentone, widow, died 7 April 1988.

McCartney, Catherine Veronica, also known as Catherine McCarthy, late of The Little Sisters of the Poor, St Joseph's Home, St Georges Road, Northcote, retired hospital assistant, died 3 November 1988.

McKenzie, Clifford Humbrae, also known as Humbrae McKenzie, late of "Tulach Ard", 41 Mouchmore Avenue, St Leonards, retired army officer, died 17 February 1989.

Morello, Albert Dominic, late of Bundoora, retired, died 5 October 1988.



*Victoria Government Gazette*

*G 21 31 May 1989 1309*

Nicholson, Margaret Denise, also known as Margaret Denise Nicholson and Margaret Denise Reid, late of Flat 18, 59 Queens Road, Melbourne, widow died 18 January 1989.

Power, Leo Albert, late of Flat 4, 8 Beech Street, Caulfield South, mail officer, died 26 January 1989.

Stivey, Charles Thomas, late of 26 Cosmos Street, Glenroy, retired carpenter, died 7 November 1988.

Dated 29 May 1989

W. J. KILPATRICK  
Managing Director  
State Trust Corporation

---

**APPOINTMENTS**

*Occupational Health and Safety Act 1985*

**APPOINTMENT OF INSPECTORS**

Pursuant to section 38 of the *Occupational Health and Safety Act 1985* the following people have been appointed as Inspectors under the Act.

Edward J. MURTAGH  
Patricia M. FRISWELL  
Robert E. JONES

PHILIP BENTLEY  
Director General  
Department of Labour

---

*Dangerous Goods Act 1985*

**APPOINTMENT OF INSPECTORS**

Pursuant to section 11 of the *Dangerous Goods Act 1985* the following people have been appointed as Inspectors under the Act.

Edward J. MURTAGH  
Patricia M. FRISWELL

PHILIP BENTLEY  
Director General  
Department of Labour

---

*Industrial Relations Act 1979*

**APPOINTMENT OF INSPECTORS**

Pursuant to section 87 of the *Industrial Relations Act 1979* the following people have been appointed as Inspectors under the Act.

Yvonne L. FORREST

PHILIP BENTLEY  
Director General  
Department of Labour

---

**STOCK DISEASES ACT 1968**

The Department of Agriculture and Rural Affairs, by decision under delegation 14.1 has appointed the following officer as an Inspector under the above Act, without additional salary.

<i>Name</i>	<i>Classification</i>
ELLIS, Patricia	Scientist (Veterinary) Class SCI (VET) 2

J. J. WRIGHT  
Chief General Manager

---

## ORDERS IN COUNCIL

*Cemeteries Act 1958*  
**APPOINTMENT OF TRUSTEES OF PUBLIC CEMETERIES**

The Governor in Council under section 3 (1) of the *Cemeteries Act 1958* makes the following appointments of Trustees of public cemeteries:

Name	Public Cemetery
Evan Robert LEWIS	Moornag
Robert Bruce PIKE	Nirranda
John Francis SHEEHAN	Heathcote
Ian Henry HARVEY	Strathdownie East
John Thomas McGRATH	" "
Ross McKINNON	" "
Kenneth Douglas McEACHERN	" "
William Vernon Francis COIN	" "
David George JOHNSTON	" "
Kevin John Kelynack HARVEY	" "

Dated 23 May 1989

Responsible Minister: •  
 CAROLINE HOGG  
 Minister for Health

KATHY OUZOUNIS  
 Acting Clerk of the Executive Council

*Cemeteries Act 1958*  
**SCALES OF FEES FOR PUBLIC CEMETERIES**

The Governor in Council under section 17 of the *Cemeteries Act 1958* consents to the making of the attached Scales of Fees in respect of the undermentioned public cemeteries:

*Cemeteries Act 1958*  
**SCALE OF FEES OF THE BORAM BORAM PUBLIC CEMETERY**

In pursuance of the powers conferred upon them by the *Cemeteries Act* the trustees of the Boram Boram Public Cemetery hereby make the following scale of fees, which shall come into operation upon publication in the *Government Gazette*, and from and after such publication every scale of fees heretofore made by the said trustees shall be and is hereby rescinded to the extent to which it conflicts with this scale.

	\$
Land for private grave	100.00
Sinking charges for 6 ft.	170.00
Sinking charges for 7 ft.	180.00
Re-opening grave (no cover)	150.00
Re-opening grave (with cover)	160.00
Second interment fee	50.00
<i>New Bush Grass Section</i>	
Purchase of land	100.00

Sinking 1.83m	170.00
Sinking 7 ft.	180.00
Plaque and lettering	300.00
Flower container	50.00
Second interment fee	50.00

E. R. KELLY, Trustee  
 I. HARRINGTON, Trustee  
 N. ROSS, Trustee

*Cemeteries Act 1958*  
**SCALE OF FEES OF THE WILLIAMSTOWN PUBLIC CEMETERY**

In pursuance of the powers conferred upon them by the *Cemeteries Act* the trustees of the Williamstown Public Cemetery hereby make the following scale of fees, which shall come into operation upon publication in the *Government Gazette*, and from and after such publication every scale of fees heretofore made by the said trustees shall be and is hereby rescinded to the extent to which it conflicts with this scale.

*Monumental Lawn* \$

Land 2.44m × 1.22m	
<i>At Need</i>	
Includes Right of Burial and First Interment	1230
<i>Pre Need</i>	
Right of Burial only—As Selected	855

*Monumental*

Land 2.44m × 1.22m	
<i>At Need</i>	
Includes Right of Burial and First Interment	1095
<i>Pre Need</i>	
Right of Burial only—As Selected	735
Interment Fee—Standard (Monumental and Lawn)	490

*Vaults*

For two caskets—Includes Right of Burial and Concrete Lined Grave only	
<i>At Need</i>	3935
<i>Pre Need</i>	4100

*Miscellaneous*

Exhumation Fee—when authorised	850
B. HEATH, Trustee	
H. B. WHITTAKER, Trustee	
J. E. PATTERSON, Trustee	
G. J. MacGILL, Manager and Secretary	

1312 G 21 31 May 1989

*Cemeteries Act 1958*

SCALE OF FEES OF THE MEMORIAL  
PARK PUBLIC CEMETERY

In pursuance of the powers conferred upon them by the Cemeteries Act the trustees of the Memorial Park Public Cemetery hereby make the following scale of fees, which shall come into operation upon publication in the *Government Gazette*, and from and after such publication every scale of fees heretofore made by the said trustees shall be and is hereby rescinded to the extent to which it conflicts with this scale.

*Cremation*

	\$
Weekdays—Adult	380
Weekdays—Child under 5 years of age	210
Cremation Pre Need	415

*Lawn Cemetery*

Land 2.44m × 1.22m	
<i>At Need</i>	
Fee includes Right of Burial and First Internment	1285
<i>Pre Need</i>	
As Selected—Right of Burial Only	855
Internment Fee—Standard	490

*Children's Section*

Land 1.83m × 0.91m	
Child under 12 years of age	485

*Disposal of Cremated Remains*

Collect from Office (24 hours notice required)	35
Registered Mail—Australia	60
Registered Mail—Overseas (Air)	80

*Miscellaneous*

Use of Chapel—Service only	100
Exhumation Fee—when authorised	850

*Memorialization*

Boulder	Six Positions	2200
Tree	Six Positions	1700
Weeping Rose	Four Positions	1700
Individual Rose	Four Positions	1100
Shrub	Two Positions	835
Sundial/Fountain	Single Position	370
Rose Garden	Single Position	300
Rockpool	Single Position	300
Memorial Walls		
"A" Niche	Single Position	220
"B" Niche	Single Position	185

Where a Memorial provides for more than one position, a positioning fee shall apply to each position after the first 90

*Victoria Government Gazette*

B. HEATH, Trustee  
H. B. WHITTAKER, Trustee  
J. E. PATTERSON, Trustee  
G. J. MacGILL, Manager and Secretary

*Cemeteries Act 1958*

SCALE OF FEES OF THE DROUIN PUBLIC  
CEMETERY

In pursuance of the powers conferred upon them by the Cemeteries Act the trustees of the Drouin Public Cemetery hereby make the following scale of fees, which shall come into operation upon publication in the *Government Gazette*, and from and after such publication every scale of fees heretofore made by the said trustees shall be and is hereby rescinded to the extent to which it conflicts with this scale.

*Lawn Section*

	\$
Land 2.44m × 1.22m	260.00
Sinking Grave to 1.85m	165.00
Sinking Grave, for each additional 0.3m (extra)	40.00
Sinking Grave oversize (extra)	55.00
Reservation of Lawn Grave site	260.00
Sinking Grave on Weekend or Public Holiday (extra)	100.00
Sinking Grave for child (across head of grave)	80.00

*Monumental Section*

Land 2.44m × 1.22m	260.00
Sinking Grave to 1.85m	165.00
Sinking Grave, for each additional 0.3m (extra)	40.00
Sinking Grave oversize (extra)	55.00
Sinking Grave on weekend or Public Holiday (extra)	110.00
To remove ledger or cover and replace	165.00
To erect headstone, holder of Burial Right permission to be required, 10% of cost	

*Re-open Charges*

To re-open grave in Lawn Section	165.00
To re-open in Monumental Section (no cover)	165.00
To re-open in Monumental Section with ledger	360.00

*Interment Fees*

Wall Niche	40.00
Lawn or Monumental Section	105.00
Interment on Weekends or Holidays	165.00
Interment of child	No Charge

Victoria Government Gazette

Memorial Wall Niche

Purchase of Wall Niche	85.00
To seal Ashes in Memorial Wall	40.00
<i>Plaques</i>	
Lawn Section	210.00
Monumental Section (includes research of site)	270.00
Wall Niche	90.00
Wall Niche Reservation Plaque	40.00

To research records for Family Tree Information

For research maximum and minimum charge	20.00
---	-------

Exhumation Charge

To exhume the remains of a body at Official Request (when requested)	650.00
--	--------

C. C. TANNER, Trustee  
I. T. GAFFNEY, Trustee  
H. P. HEARN, Trustee

Cemeteries Act 1958

SCALE OF FEES OF THE HORSHAM PUBLIC CEMETERY

In pursuance of the powers conferred upon them by the Cemeteries Act the trustees of the Horsham Public Cemetery hereby make the following scale of fees, which shall come into operation upon publication in the *Government Gazette*, and from and after such publication every scale of fees heretofore made by the said trustees shall be and is hereby rescinded to the extent to which it conflicts with this scale.

General Cemetery

Private Graves

	\$
Land, 2.4m x 1.22m	310.00
Sinking Grave, Adult	310.00

Public Graves

Sinking of Grave, number plate and Interment (Adult)	140.00
Sinking of Grave, number plate and Interment (child)	85.00
Sinking each 0.3m past 1.8m	60.00
Sinking Grave for Oversized Casket	195.00
Interment not in prescribed hours or on Saturdays or Public Holidays	160.00
Maintenance of Graves by Trustees—Annual fee per grave (optional)	20.00
Memorial Wall Niche and Plaque	175.00

Lawn Cemetery

Undenominational

Lawn Grave 2.44m x 1.22m including first Interment (Adult)	625.00
--	--------

G 21 31 May 1989 1313

Second Interment in same Grave	375.00
Additional fee for Bronze Plaque, each	170.00
Lawn Grave for cremated ashes including first interment of ashes	270.00
Second Interment of cremated ashes	125.00
Flower Container supplied by Trust, Bronze	45.00
Flower Container supplied by Trust, Plastic	25.00

A. W. UEBERGANG, Trustee  
R. W. SCHUBERT, Trustee  
J. T. SHARRY, Trustee

Cemeteries Act 1958

SCALE OF FEES OF THE UPPER YARRA PUBLIC CEMETERY

In pursuance of the powers conferred upon them by the Cemeteries Act the trustees of the Upper Yarra Public Cemetery hereby make the following scale of fees, which shall come into operation upon publication in the *Government Gazette*, and from and after such publication every scale of fees heretofore made by the said trustees shall be and is hereby rescinded to the extent to which it conflicts with this scale.

Private Graves

	\$
Lawn Area—Non denominational Bronze Plaque memorials only area—2.44m x 1.22m allowing two interments	300.00
Memorial—Denominational area for approved monumental works or bronze plaques—2.44m x 1.22m allowing two interments	300.00

Interment Fees

Lawn and monumental areas	300.00
Ashes in private grave	60.00

Interment of Cremated Remains

Reception of ashes of cremation and placement of a 280mm x 230mm bronze plaque supplied by the Trust at a Garden Bed	290.00
--	--------

Cemetery Plaque Fees

Plaques supplied and set in position by the Trust Special dual conversion decorative design to commemorate one or two persons with the same surname. Includes first attachment and inbuilt flower container. Measures 560mm x 305mm	385.00
Second attachment to dual conversion plaque	60.00
Standard Lawn Plaque (381mm x 279mm)	250.00

1314 G 21 31 May 1989

Decorative Lawn Plaque with decorative design and inbuilt flower container (381mm × 279mm)	265.00
<i>Miscellaneous Charges</i>	
Exhumation fee (only if authorised)	500.00
Permission to erect, repair or add to any monument	50.00
Cancellation fee—in respect of pre-purchased graves—10% of amount of reservation	
Search of Records	10.00

B. S. HALIT, Trustee  
E. F. COLVERSON, Trustee  
C. A. OLLREY, Trustee

Dated 23 May 1989

Responsible Minister:

CAROLINE HOGG

Minister for Health

KATHY OUZOUNIS

Acting Clerk of the Executive Council

*Crown Land (Reserves) Act 1978*

#### NOTICE OF INTENTION

The Governor in Council under section 10 of the *Crown Land (Reserves) Act 1978* gives notice of intention to revoke the following temporary reservations:

**BRIAGOLONG**—The temporary reservation by Order in Council of 20 November 1962 of 5716 square metres of land in the Parish of Briagolong as a site for a Quarry—(Rs. 4593).

**DROUIN EAST**—The temporary reservation by Order in Council of 3 June 1969 of 657 square metres of land shown as Crown Allotment 77B, Parish of Drouin East on Parish Plan No. 2547 lodged in the Central Plan Office—(Rs. 9151).

**MARMA (STATION CREEK)**—The temporary reservation, by Order in Council of 27 August 1894 of 19.02 hectares, more or less, of land in the Parish of Marma, being a strip of land following the course of the Ashens Creek through Allotments 25, 24, 23, 22, 21A, 19A, 18, 17, 11, 1 and 4 so far only as the portion through reserved forest shown as Allotments 11 and 1 on Plan M.457 (2) lodged in the Central Plan Office—(Rs. 13936).

**SANDHURST (BENDIGO)**—The temporary reservation by Order in Council of 8 January 1980 of 674 square metres of land being Crown Allotment 4B, Section 18, at Bendigo, Parish of Sandhurst as a site for Departmental Residence—(Rs. 10755).

**STEWARTON**—The temporary reservation by Order in Council of 20 August 1883 of 4047 square metres of land adjoining Crown Allotment 49, Parish of Stewarton as a site for Public Purposes (State School)—(Rs. 14045).

#### *Victoria Government Gazette*

**WANGARATTA**—The temporary reservation by Order in Council of 25 October 1966 of 1088 square metres of land in Section 6, Township of Wangaratta, Parish of Wangaratta North as a site for Public Purposes (Forests Department purposes)—(Rs. 8648).

**WHITFIELD**—The temporary reservation by Order in Council of 20 June 1967 of 1771 square metres of land in Section 1, Parish of Whitfield as a site for Public Purposes (Forests Department purposes)—(Rs. 8713).

Dated 23 May 1989

Responsible Minister:

KAY SETCHES

Minister for Conservation, Forests and Lands

KATHY OUZOUNIS

Acting Clerk of the Executive Council

*Crown Land (Reserves) Act 1978*

#### REVOCATION OF TEMPORARY RESERVATIONS

The Governor in Council under section 10 of the *Crown Land (Reserves) Act 1978* revokes the following temporary reservations:

**BARRARBOOL**—The temporary reservation by Order in Council of 8 July 1902 of 8.326 hectares of land in the Parish of Barrarbool as a site for Water Supply purposes, revoked as to part by various Orders, so far only as the portion containing 519 square metres being Crown Allotment 1D, Section 16, Parish of Barrarbool as shown on Certified Plan No. 109414—(Rs. 7643).

**BENALLA**—The temporary reservation by Order in Council of 27 February 1963 of 860 square metres of land in Section 23, Township of Benalla, Parish of Benalla as a site for the purposes of the Forests Act—(Rs. 8212).

**MOONDARRA**—The temporary reservation by Order in Council of 12 March 1952 of 7866 square metres of land in Section B, Parish of Moondarra, as a site for Police purposes, revoked as to part by Order in Council of 22 April 1969, so far as the balance remaining of 7386 square metres—(Rs. 6868).

**PYRAMID HILL**—The temporary reservation by Order in Council of 9 November 1971 of 6.07 hectares of land in the Township of Pyramid Hill, Parish of Mologa as a site for State School purposes—(Rs. 9541).

**SHEPPARTON**—The temporary reservation by Order in Council of 23 May 1967 of 632 square metres of land in the Parish of Shepparton as a site for Public Purposes (Police Purposes)—(Rs. 8676).

**TRUGANINA**—The temporary reservation by Order in Council of 16 October 1979 of 18.51 hectares of land being Crown Allotment 4C,

*Victoria Government Gazette*

Section 5, Parish of Truganina as a site for Public Park and Public Recreation so far only as the purpose of a Public Park in concerned—(Rs. 10684).

**TURRUMBERRY NORTH**—The temporary reservation by Order in Council of 29 January 1878 of 48.55 hectares of land west of Crown Allotment 27, Parish of Turrumberry North as a site for Watering purposes—(Rs. 13209).

**WILL WILL ROOK (FAWKNER)**—The temporary reservation by Order in Council of 12 September 1978 of 585.2 square metres of land being Crown Allotment 4D, Parish of Will Will Rook as a site for Public Purposes (Social Welfare Department purposes)—(Rs. 10615).

Dated 23 May 1989

Responsible Minister:

**KAY SETCHES**

Minister for Conservation, Forests and Lands

**KATHY OUZOUNIS**

Acting Clerk of the Executive Council

*Crown Land (Reserves) Act 1978*  
**CROWN LANDS TEMPORARILY  
RESERVED**

The Governor in Council under sections 4 and 7 of the *Crown Land (Reserves) Act 1978* temporarily reserves for the purposes mentioned and also excepts from prospecting or from occupation for mining purposes under any miners right the following Crown lands:

**MUNICIPAL DISTRICT OF THE SHIRE OF  
STAWELL**

**MALAKOFF**—Management of Wildlife, 39 hectares, more or less, of land in the Parish of Malakoff shown coloured red on plan marked M:16-12-88 attached to Department of Conservation, Forests and Lands correspondence No. Rs. 509 and being the land described in the Land Conservation Council's Final Recommendation C2 for the North Central Area—(Rs. 509).

**MUNICIPAL DISTRICT OF THE SHIRE OF  
WIMMERA**

**WAIL**—Management of Wildlife, 15 hectares, more or less, of land in the Parish of Wail shown bordered pink on plan marked W1/16-5-1988 attached to Department of Conservation, Forests and Lands correspondence No. Rs. 13959 and being the land described in the Land Conservation Council's Final Recommendation C29 for the Wimmera Area excluding gravel roads—(Rs. 13959).

**MUNICIPAL DISTRICT OF THE SHIRE OF  
DUNDAS**

**WOHLPOOER**—Management of Wildlife, 54 hectares, more or less, of land in the Parish of

*G 21 31 May 1989 1315*

Wohlpooper shown bordered red on plan marked W1/25-11-87 attached to Department of Conservation, Forests and Lands correspondence No. Rs. 13978 and being land described in the Land Conservation Council's Final Recommendation D68 for the South-Western Area, District 2, excluding a gravel road—(Rs. 13978).

Dated 23 May 1989

Responsible Minister:

**KAY SETCHES**

Minister for Conservation, Forests and Lands

**KATHY OUZOUNIS**

Acting Clerk of the Executive Council

*Crown Land (Reserves) Act 1978*  
**CROWN LANDS PERMANENTLY  
RESERVED**

The Governor in Council under sections 4 and 7 of the *Crown Land (Reserves) Act 1978* permanently reserves for the purpose mentioned and also excepts from prospecting or from occupation for mining purposes under any miners right the following Crown lands:

**MUNICIPAL DISTRICT OF THE SHIRE OF  
STAWELL**

**KIRKELLA**—Conservation of an area of natural interest, 8.809 hectares being Crown Allotment J 3A, Parish of Kirkella as shown on Certified Plan No. 108706 lodged in the Central Plan Office.

**KIRKELLA**—Conservation of an area of natural interest, 2.4 hectares, more or less, being Crown Allotments 66D1, 66D2, 66D3 and 66D4, Parish of Kirkella as indicated by hatching on plan hereunder—(Rs. 11710).

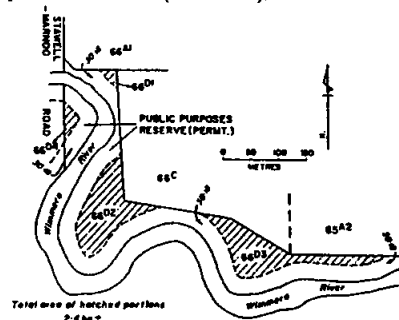

Dated 23 May 1989

Responsible Minister:

**KAY SETCHES**

Minister for Conservation, Forests and Lands

**KATHY OUZOUNIS**

Acting Clerk of the Executive Council

Corrections Act 1986

Section 11

APPOINTMENT OF POLICE GAOL

The Governor in Council appoints under section 11 of the *Corrections Act* 1986 the premises described hereunder to be a police gaol to hold a person for a term not exceeding three days.

St Kilda, 88-98 Chapel Street, St Kilda.	South East Corner of St Kilda Police Station.	Reinforced concrete Building 15.78m x 11.5m approximately	Parish of Prahran, County of Bourke, Crown Allotment 136c
--	---	--	---

Dated 23 May 1989

Responsible Minister:

S. M. CRABB

Minister for Police and Emergency Services

KATHY OUZOUNIS  
Acting Clerk of the Executive Council

*Housing Act* 1983

EXTINGUISHMENT OF AN EASEMENT

The Governor in Council under section 16 of the *Housing Act* 1983 extinguishes the easement indicated by hatching on the plan hereunder.

COUNTY OF BULN BULN  
PARISH OF NARRACAN  
PART CROWN ALLOTMENT 5B

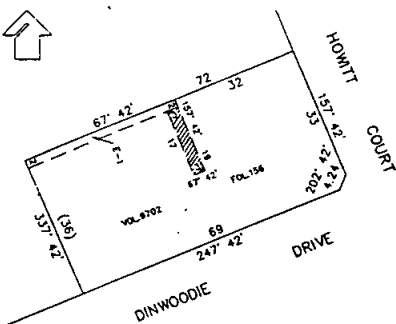

E-1 DRAINAGE AND SEWERAGE EASEMENT

Dated 23 May 1989

Responsible Minister:

BARRY PULLEN

Minister for Housing and Construction

KATHY OUZOUNIS

Acting Clerk of the Executive Council

*Historic Buildings Act* 1981 (No. 9667)

AMENDMENT OF REGISTER OF HISTORIC BUILDINGS

Under section 14 of the *Historic Buildings Act* 1981 the Administrator in Council amends the Register by adding Historic Building No. 708—

Young and Jackson's Princes Bridge Hotel  
Cnr Swanston and Flinders Streets,  
Melbourne

to the extent of all of the buildings and all of the land entered in the Register Book Volume 9586 Folio 955 and the painting "Chloe" by Jules Lefebvre.

Dated: 30 May 1989

Responsible Minister

T. W. ROPER

Minister for Planning and Environment

KATHY OUZOUNIS

Acting Clerk of the Executive Council

*Historic Buildings Act* 1981 (No. 9667)

AMENDMENT OF REGISTER OF HISTORIC BUILDINGS

Under section 14 of the *Historic Buildings Act* 1981 the Administrator in Council amends the Register by adding Historic Building No. 737—

Residence

5 Bowden Street, Castlemaine

to the extent of all of the buildings and the land hatched which is entered in the Register Book in the Title Memorial Number 176 Book 717.

Dated 30 May 1989

Responsible Minister

T. W. ROPER

Minister for Planning and Environment

KATHY OUZOUNIS

Acting Clerk of the Executive Council

*Kew and Heidelberg Lands Act* 1933

APPOINTMENT OF TRUSTEE

Yarra Bend Park

The Governor in Council under section 6 of the *Kew and Heidelberg Lands Act* 1933 appoints the undermentioned person as Trustee of the balance of the land in the Parishes of Boroondara



*Victoria Government Gazette*

and Jika Jika permanently reserved pursuant to Order in Council of 26 March 1935 as a site for Public Park and Recreation and known as "Yarra Bend Park":

Daryl OLDAKER

in place of:

Joseph ORMANDO (retired)

provided that the said Daryl Oldaker shall hold office as a Trustee for so long only as he continues to be a Councillor and the elect of the Council of the City of Kew.

Dated 23 May 1989

Responsible Minister:

KAY SETCHES

Minister for Conservation, Forests and Lands

KATHY OUZOUNIS

Acting Clerk of the Executive Council

*Land Act 1958*

**ABOLITION OF COMMON**

The Governor in Council under section 184 of the *Land Act 1958* abolishes the following Common:

WICKLIFFE—The remaining portions of the Wickliffe Town Common proclaimed on 6 November 1865 and 18 May 1875—(C 77058).

Dated 23 May 1989

Responsible Minister:

KAY SETCHES

Minister for Conservation, Forests and Lands

KATHY OUZOUNIS

Acting Clerk of the Executive Council

*Road Safety Act 1986*

**APPROVED ANALYSTS**

The Governor in Council acting under section 57 of the *Road Safety Act 1986* revokes the Order made on 25 October 1988 and published in the *Government Gazette* on 9 November 1988 and by this Order approved each of the following as a properly qualified analyst:

BOWMAN, Janette Anne

BROWN, Robert Gordon

CANAVAN, Gavan John

CUTTING, Graham John

GIDLEY, David Neil

HALL, Nigel Murray George

HAYES, Robert John

LILLIS, Naomi Jean

PERKAL, Michael

PLESS, Michael Roger

PRESTON, William Lyle Kent

QUINN, Catherine Anne

ROSS, Peter

TAUPIN, Jane Moira

G 21 31 May 1989 1317

Thatcher, Peter John

WHITE, Malcolm John

WYNN, Phillip David

ZWOLAK, Bernard

Dated 23 May 1989

Responsible Minister:

J. H. KENNAN

Minister for Transport

KATHY OUZOUNIS

Acting Clerk of the Executive Council

*Water and Sewerage Authorities (Restructuring) Act 1983*

*Water Act 1958*

**SHEPPARTON WATER BOARD**

Extensions of Shepparton Waterworks District  
Approved

Sites of Pipelines Approved

The Governor in Council under the provisions of the *Water and Sewerage Authorities (Restructuring) Act 1983* and the *Water Act 1958* approves of the extensions to the Shepparton Waterworks District and the sites of pipelines as shown in red and yellow respectively on the accompanying plans (Corr. No. 002170/50 (Plans A-D)).

Dated 26 April 1989

Responsible Minister:

R. W. WALSH

Minister for Water Resources

KATHY OUZOUNIS

Acting Clerk of the Executive Council

*Water and Sewerage Authorities (Restructuring) Act 1983*

*Water Act 1958*

**SHEPPARTON WATER BOARD**

Extension of Shepparton Waterworks District  
Approved

The Governor in Council under the provisions of the *Water and Sewerage Authorities (Restructuring) Act 1983* and the *Water Act 1958* approves of the extension to the Shepparton Waterworks District as shown in red on the accompanying plan (Corr. No. 002170/51).

Dated 26 April 1989

Responsible Minister:

R. W. WALSH

Minister for Water Resources

KATHY OUZOUNIS

Acting Clerk of the Executive Council

1318 G 21 31 May 1989

*Water and Sewerage Authorities (Restructuring)  
Act 1983*

**RURAL CITY OF WODONGA**

**Approval to Sale of Land**

The Governor in Council under the provisions of the *Water and Sewerage Authorities (Restructuring) Act 1983* approves of the sale of land described as Lots 3 and 4 L.P. No. 215510T Certificate of Title Vol. 9727, Folio 887, Township of Wodonga, Parish of Wodonga, by the Rural City of Wodonga (Correspondence No. 6167/25).

Dated 18 April 1989

Responsible Minister:

R. W. WALSH

Minister for Water Resources

KATHY OUZOUNIS

Acting Clerk of the Executive Council

---

*Water Act 1958*

**RURAL WATER COMMISSION OF  
VICTORIA**

**Goulburn–Murray Irrigation District**

**Rochester Irrigation Area**

**Portions Excised**

The Governor in Council under the provisions of section 62B(6) of the *Water Act 1958* approves of the excision of the lands shown by green colour on the accompanying plans (Corr. Nos 85/27318 and 89/01538) from the Rochester Irrigation Area of the Goulburn–Murray Irrigation District as on and from 30 June 1989.

Responsible Minister:

R. W. WALSH

Minister for Water Resources

KATHY OUZOUNIS

Acting Clerk of the Executive Council

---

*Victoria Government Gazette*

**TENDERS**

**MINISTRY OF HOUSING AND  
CONSTRUCTION—VICTORIA**

Major Works Tenders are invited for the purposes indicated hereunder and must be forwarded in the Ministry's coloured envelope and endorsed "Major Works Tender for \_\_\_\_\_".

The tender must either be—

lodged by hand in the box marked "Tenders" on First Floor, 2 Treasury Place, Melbourne, received by mail.

received by facsimile machine on (03) 651 1738 and immediately confirmed by mail on the Ministry's Tender Form.

No tender will be considered if received later than 2.00 p.m. on the closing date indicated hereunder for that work, or received by any other means.

Note: Telex and telegram tenders are no longer accepted. Tenders received by a mail delivery after the closing date and time are no longer accepted.

Tender documents are available for pick-up from the Contracts Office, Room 44, Ground Floor, 2 Treasury Place, Melbourne between 8.30 a.m.—12.30 p.m. and 1.30 p.m.—4.00 p.m. (posting will only occur outside 32 km from the G.P.O.) and where indicated at the Provincial Works Office.

Enquiries: Telephone (03) 651 2453/4.

**Wednesday, 7 June 1989**

CARAMUT—Cyclic maintenance, Primary School. (W.O. Geelong and Warrnambool.)

HEATHERTON—Installation of flat aluminium wall cladding, Acute Admissions unit—Hospital.

HEYWOOD—Construction of bus bays and car park, stage 1, part A, Consolidated School. (W.O. Geelong, Warrnambool and Horsham.)

KEW—New brick seed store enclosure, Land Protection Office—378 Cotham Road—Conservation, Forests and Lands.

MURRUMBEENA—Staff/administration upgrade, Primary School.

RICHMOND—Fire protection—Smoke doors, fire walls and electrical work, High School.

WERRIBEE—Upgrade and additions, Meat Research Centre, Animal Research Institute.

**Wednesday, 14 June 1989**

BENALLA—Upgrade of original brick building, Stage 3, Regional Headquarters—Ministry of Education. (W.O. Benalla.) *Re-advertised.*

BENDIGO—Upgrade of thermal fire alarm system, Loddon Campaspe College of T.A.F.E.

HALLS GAP—Construction of a four-man police station and three bedroom residence, Police Station and Residence. (W.O. Horsham.)

PORT MELBOURNE—Contract 1, 1989/90: Supply, delivery and assembly of modular buildings at rates, F.O.G., M.H.C. Storeyard—69 Salmon Street. (W.O. Bendigo and Ballarat.)

**Wednesday, 21 June 1989**

MANYUNG—Construction of kitchen/dining room, recreation camp—Department of Sport and Recreation.

SPOTSWOOD—Removal of asbestos, Science and Technology Museum.

**Wednesday, 28 June 1989**

MELBOURNE—Supply of radio equipment, low power base stations—376 Russell Street—Police Complex.

**BARRY PULLEN**

Minister for Housing and Construction  
Ministry of Housing and Construction  
Melbourne, 22 May 1989

**PRIVATE  
ADVERTISEMENTS**

*Planning and Environment Act 1987*  
**BERWICK PLANNING SCHEME**  
Notice of Amendment  
Amendment No. L7

The City of Berwick has prepared Amendment No. L7 to the Local Section of the Berwick Planning Scheme.

The amendment proposes to reserve land situated in Richardson Grove, Berwick for Proposed Public Purposes 19 (Local Government).

The amendment can be inspected at the City of Berwick, Municipal Offices, Magid Drive, Fountain Gate; the Ministry for Planning and Environment, Ground Floor, The Olderfleet Buildings, 477 Collins Street, Melbourne; the Ministry for Planning and Environment, Metropolitan South and Westernport Region, 33-39 High Street, Cranbourne.

Submissions about the amendment must be sent to: the Town Clerk, City of Berwick, PO Box 200, Berwick, 3806 by 3 July 1989.

P. J. NORTHEAST  
City Manager  
5493

*Planning and Environment Act 1987*  
**NOTICE OF AMENDMENT TO BERWICK  
PLANNING SCHEME**  
Amendment No. L7

The City of Berwick has prepared Amendment No. L7 to the Local Section of the Berwick Planning Scheme.

The amendment proposes to reserve land situated in Richardson Grove, Berwick for Proposed Public Purposes 19 (Local Government).

The amendment can be inspected at City of Berwick, Municipal Offices, Magid Drive, Fountain Gate; the Ministry for Planning and Environment, Ground Floor, The Olderfleet Buildings, 477 Collins Street, Melbourne; the Ministry for Planning and Environment, Metropolitan South and Westernport Region, 33-39 High Street, Cranbourne.

Submissions about the amendment must be sent to the Town Clerk, City of Berwick, P.O. Box 200, Berwick 3806 by 3 July 1989.

P. J. NORTHEAST  
City Manager  
5392

**CITY OF BERWICK**  
Declaration of Public Highway  
Pursuant to section 522 of the *Local Government Act 1958*, the Council of the City of

Berwick hereby orders and directs that all that piece of land, as shown hatched on the Plan hereunder and more particularly described on Certificate of Title Volume 9490, Folio 208 on Plan of Subdivision No. 140381, which the City of Berwick is the registered proprietor, shall be a public highway on and from the date of publication of this Order in the *Government Gazette*.

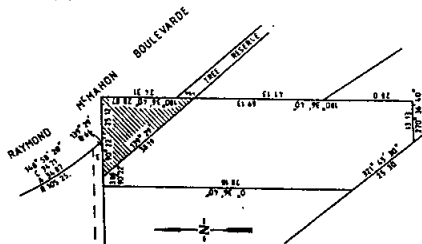

P. J. NORTHEAST  
City Manager  
5395

**CITY OF BRIGHTON**  
By-law No. 235

Notice is hereby given that the City of Brighton has made the following By-law No. 235, pursuant to section 207 of the Local Government Act.

By-law No. 235 for the purpose of:

controlling and regulating the times at which building works can be carried out on any allotment within the municipality with a view to preventing objectionable noise from building works at unreasonable times.

A copy of the By-law is available for public inspection, free of charge, during office hours at the Municipal Offices, Boxshall Street, Brighton.

The resolution adopting this By-law was agreed to by the Council on 17 April 1989, and confirmed on 15 May 1989.

R. J. COBAIN  
Town Clerk  
5421

**CITY OF BRIGHTON**  
By-law No. 234

Notice is hereby given that the City of Brighton has made the following By-law No. 234, pursuant to section 207 of the Local Government Act.

By-law No. 234 for the purposes of repealing By-law 232:

- (a) preventing and extinguishing fires;
- (b) suppressing nuisances;
- (c) regulating the times during which incinerators may be used on property used

*Victoria Government Gazette*

wholly or partly for residential purposes; and

(d) generally for maintaining the good rule and government of the municipality.

A copy of the By-law is available for public inspection, free of charge, during office hours at the Municipal Offices, Boxshall Street, Brighton.

The resolution adopting this By-law was agreed to by the Council on 17 April 1989, and confirmed on 15 May 1989.

R. J. COBAIN  
Town Clerk

5420

**CITY OF COBURG**  
Road Discontinuance

Pursuant to section 528 (2) of the *Local Government Act 1958*, the Council of the City of Coburg at its ordinary meeting held on 22 May 1989, resolved that the road bounded by Bell Street, Westgate Street, Anderson Street and Cumberland Road, Pascoe Vale and shown hatched on the plan hereunder, be discontinued and sold by private treaty.

Notwithstanding such discontinuance the Council of the City of Coburg and the Melbourne and Metropolitan Board of Works shall continue to have and possess the same right, title, power, authority or interest in or in relation to the whole of the land shown hatched on the said plan as it had possessed prior to such discontinuance.

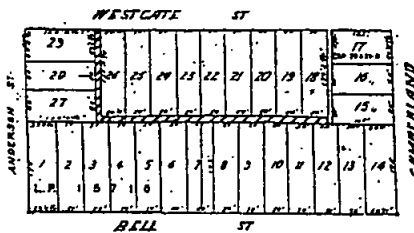

J. R. DIFFEN  
City Manager

5447

**CITY OF CROYDON**  
By-Law No. 69

Regulating Incinerators and Fires By-Law

A by-law of the City of Croydon, has been made under sections 197 and 198 of the *Local Government Act* and numbered 69, for the purpose of restricting the lighting of fires whether in the open or in an incinerator to the hours between 10.00 a.m. and 3.00 p.m. Tuesday to Saturday inclusive, except where a permit has been obtained from an authorised officer.

As required by section 205 of the *Local Government Act 1958* a copy of the by-law is open for inspection, free of charge, at the

G 21 31 May 1989 1321

Municipal Offices, Civic Square, Croydon during office hours.

T. L. MAHER  
Chief Executive Officer

5450

**CITY OF GEELONG**  
MELBOURNE AND GEELONG  
DEBENTURES  
INSCRIBED STOCK AND MORTGAGES  
ACTS

Loan No. 83

Notice is hereby given that the Council of the City of Geelong intends to borrow the principal sum of \$320 000 for the following purposes:

- Roadworks (Carr Street/St. Albans Road)
- Footpath Construction
- Construction of public toilets
- Drainage (Ormond Road)
- Improvements at North Geelong Park
- Development of new Council Depot at South Geelong

The period of the loan shall be four years due 30 June 1993, after which date the term of the loan may be extended in consecutive four-year periods to a total of 10 years. Repayments of the loan will be by equal half-yearly instalments based on a 10 year repayment schedule. The rate of interest payable during the initial four-year period will be 15.6 per cent per annum.

T. J. T. NEAL  
Town Clerk and  
Chief Administrative Officer

5489

**CITY OF KEW**  
Discontinuance of Road

Pursuant to section 528 (2) of the *Local Government Act 1958* the Council of the City of Kew at the Ordinary Meeting of Council held on 23 May 1989 directed—

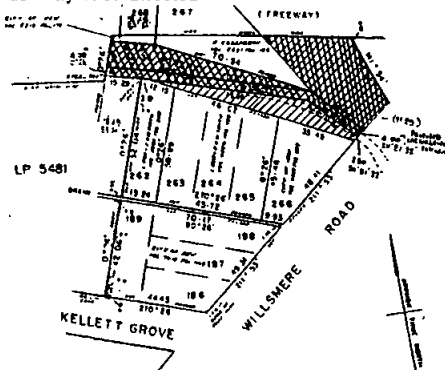

1. That the road shown hatched and crosshatched on the plan shown below shall be

1322 G 21 31 May 1989

discontinued upon publication of this resolution in the *Government Gazette*.

2. That the land in the road shall vest in the municipality with the land shown hatched to be sold by public auction; the land shown crosshatched to be retained for municipal purposes.

ADRIAN HALLIDAY  
5481 Chief Executive and Town Clerk

CITY OF KEILOR  
Street Renaming

Notice is hereby given that the Council of the City of Keilor resolved on 4 April 1989, that that portion of Assembly Drive running in a westerly direction from Tullamarine Park Road and located in the north eastern corner of the Tullamarine Industrial Park Estate, Keilor Park, be renamed "Prima Court" in accordance with the provisions of section 535 (4) of the *Local Government Act 1958* (as amended).

That portion of Assembly Drive to be renamed Prima Court is shown hatched on the hereunder plan.

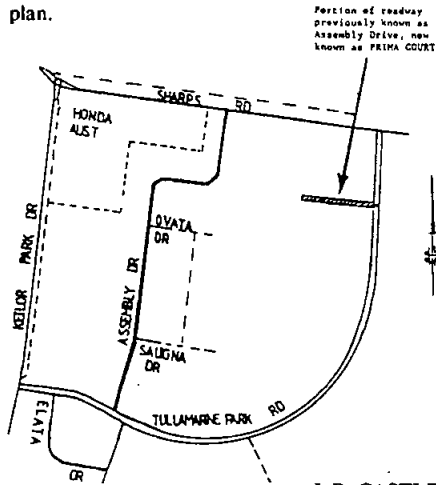

5422

J. R. CASTLE  
Town Clerk

CITY OF MALVERN  
Road Discontinuance

Pursuant to section 528 (2) (a) of the *Local Government Act 1958* (as amended) the Council of the City of Malvern, after consultation with public authorities and the advertising of its intention and notification to the required proprietors of the land and the owners and occupiers of any land abutting or immediately adjacent to the Road, has by resolution at its Ordinary Meeting held on 15 May 1989 resolved that the Road adjacent to No. 7 and No. 9 Warner

Victoria Government Gazette

Street, Malvern and shown hatched on the Plan hereunder be discontinued and sold by private treaty.

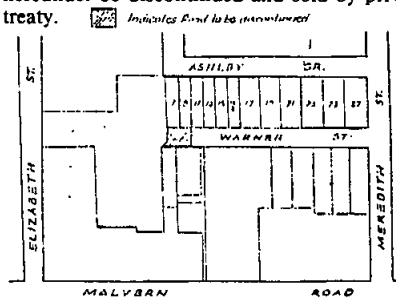

Notwithstanding such discontinuance the Melbourne and Metropolitan Board of Works and Gas and Fuel Corporation of Victoria shall continue to have and possess the same right, title, power, authority or interest in or in relation to the section of land shown hatched on the said Plan as it had or possessed prior to such discontinuance with respect to or in connection with any drain or pipes laid or erected in or over such land for the purpose of sewerage and gas and water mains.

5439

CITY OF MARYBOROUGH  
By-Law 93—Animals By-law

Notice is given that the City of Maryborough has made By-law No. 93—"Animals By-law".

The By-law in summary, is for the purpose of:

- (a) regulating the keeping of animals (including birds) and regulating or prohibiting the keeping of any place or storage of any things which in the opinion of the Council may be offensive, injurious to health or dangerous;
- (b) fixing subject to Part IV of the *Health Act 1958*, the distance from any dwelling within which it shall be lawful to keep any such place or to store any such thing;
- (c) fixing subject to Part IV of the *Health Act 1958* the limits within which it shall be unlawful to keep swine or pig-sties;
- (d) providing for the health of the residents in the municipal district and against the spreading of contagious or infectious diseases;
- (e) controlling and regulating the use of premises with a view to preventing objectionable noises at unreasonable times;
- (f) suppressing nuisances;
- (g) regulating the keeping of animals, and birds with power to limit the number of animals and birds kept on any property within any area within the municipal

district set forth in this By-law and declared herein to be a populous or residential area and/or to prohibit the keeping of any specified kind of animal or bird in such area;

- (h) prohibiting or regulating the sale or purchase or the exposing for sale of animals or birds in any street, road or public place;
- (i) generally maintaining the good rule and government of the Municipality and for other purposes.

5449

CITY OF MELBOURNE

By-Law No. 563

Notice is given that, at meeting held on 20 March 1989 and 17 April 1989, the Council made, passed and confirmed a By-law titled:

"A By-law of the City of Melbourne made under section 93 of the Health Act 1958 and numbered 563 with respect to preventing or regulating the deposit of refuse and rubbish upon streets and other lands and places under the control of the Council of the City of Melbourne and with respect to the provision, use, standards and control of containers for the deposit and collection of refuse and rubbish (whether temporary or otherwise) and with respect to certain other matters".

The By-law may be cited as "The City of Melbourne Disposal of Refuse By-law". The By-law repeals previous By-laws (Nos. 399 and 470) dealing with the disposal of refuse and provides for regulating or preventing the deposit of refuse and rubbish upon streets and other lands and places under the control of the City of Melbourne by detailing—

- (a) general provisions concerning the disposal of refuse (clauses 5, 6 and 7);
- (b) standards for refuse containers (clauses 8, 9, 10 and 11);
- (c) conditions for the cleanliness and condition of refuse containers (clauses 12 and 13);
- (d) permissible waste and their storage in containers (clauses 14 and 15);
- (e) the procedure for the disposal of hazardous waste (clause 16);
- (f) the procedure for the disposal of recyclable material (clause 17);
- (g) the conditions for the storage of waste and recyclable material (clauses 18 and 19);
- (h) conditions for the placement of waste and recyclable material for collection (clauses 20, 21 and 23);
- (i) a provision for shared storage of waste (clause 24);

- (j) what constitutes a breach of the By-law (clause 25); and
- (k) what constitutes hazardous waste from a domestic origin (schedule 2) and non-domestic origin (schedule 3).

A copy of the By-law is open for inspection free of charge, during the hours of 8.00 a.m. to 5.00 p.m. each day Monday to Friday at the Corporate Services Department, 3rd Floor, Town Hall Administration Building, Swanston Street, Melbourne.

D. N. BETHKE  
Chief Executive Officer  
and Town Clerk

5483

CITY OF MILDURA  
APPOINTMENT OF POUND

Benetook Avenue, Mildura

Notice is hereby given, that the Council of the City of Mildura at its meeting held on 20 March 1989 appointed land situated at the Municipal Depot, Benetook Avenue, Mildura being part of Lot 4, Section 28, Block F, on Plan of Subdivision No. 2380, more particularly described in Certificate of Title Volume 9144, Folio 803 (as shown on the plan below), as a pound in accordance with section 4 of the Pounds Act 1958 (as amended).

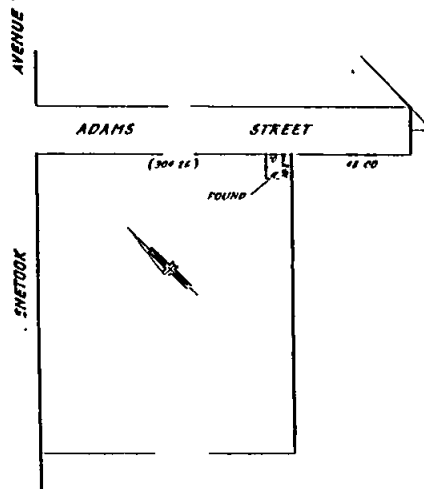

CITY OF MILDURA  
POUND  
SCALE - 1:1000

5491

06-A-52

DAMIAN B. GOSS  
Town Clerk and  
Chief Executive

5491

**CITY OF MILDURA**  
**Stockpound Fees**  
**Benetook Avenue, Mildura**

Notice is hereby given that the Council of the City of Mildura at its meeting held on 4 May 1989 confirmed the adoption of Special Order of the following prescribed fees at the City of Mildura Stockpound, Municipal Depot, Benetook Avenue, Mildura, pursuant to the *Pounds Act 1958* (as amended) and the *Local Government Act 1958* (as amended).

*Pounds Act 1958*

**TABLE OF RATES TO BE CHARGED FOR THE TRESPASS OF CATTLE AND THEIR SUSTENANCE WHILE IMPOUNDED**

**A For Trespass**

<i>Description of Cattle Trespassing</i>	<i>Upon Tillage land enclosed by a substantial fence</i>	<i>Upon land other than tillage land enclosed by a substantial fence</i>
	\$	\$
For every sheep	2	1
For every goat	10	5
For every pig	10	5
For every head of other cattle	10	5
In addition for the trespass of any entire horse		30
In addition for the trespass of any bull		30
In addition for the trespass of any ram		30
In addition for the trespass of any billy-goat		30

**B. For Sustenance**

<i>Description of Cattle</i>	<i>Amount to be charged daily for sustenance while impounded</i>
	\$
For every sheep	2
For every goat	4
For every pig	4
For every head of other cattle	4

A release fee of \$30.00 per head of cattle as defined in the *Pounds Act 1958*. A fee of \$2.00 in addition to any costs incurred by Council in relation to postage and/or advertising in accordance with the *Pounds Act 1958*.

*Note:* Section 10A of the *Pounds Act 1958* provides that where a person intending to impound cattle conveys or drives the cattle to the pound or makes arrangements for the cattle to be conveyed or driven to the pound, there shall be payable as a transport rate the expenses reasonably incurred by him in conveying or driving the cattle to the pound or in making arrangements for conveying or driving the cattle to the pound.

DAMIAN B. GOSS

5492

Town Clerk/Chief Executive

**CITY OF MILDURA**  
**Appointment of Pound Keeper**  
 Notice is hereby given that the Council of the City of Mildura at its meeting held on 20 March 1989 appointed Mr Raymond George Lyons as Pound Keeper for the City of Mildura pursuant to the *Pounds Act 1958* (as amended).

DAMIAN B. GOSS  
 Town Clerk and  
 Chief Executive

5490

**CITY OF OAKLEIGH**  
**Road Discontinuance**  
 Pursuant to section 528 (2) of the *Local Government Act 1958*, (as amended), the Council

of the City of Oakleigh, after consultation with the public authorities and the advertising of its intention and notification to the registered proprietor of the land, and owners and occupiers of any land abutting or immediately adjacent to the road, as directed, hereby resolves as follows:

“That—

- (a) the land identified on plan hereunder being Part of Crown Grant No. 33902, 1855 as shown on C/T Vol. 510, Fol. 868 commonly known as Ryans Road (East of Deals Road) is not reasonably required as a road for public use.
- (b) the said portion of road be discontinued upon publication of this resolution in the *Government Gazette*.



- (c) the land in the said road shall vest in the City of Oakleigh until sold by private treaty to the abutting property owner.
- (d) notwithstanding discontinuance, Telecom Australia shall continue to have and possess the same right title power authority or interest in or in relation to the whole of the land shown by hatching on the said plan as it had or possessed prior to such discontinuance with respect to access to existing Telecom plant."

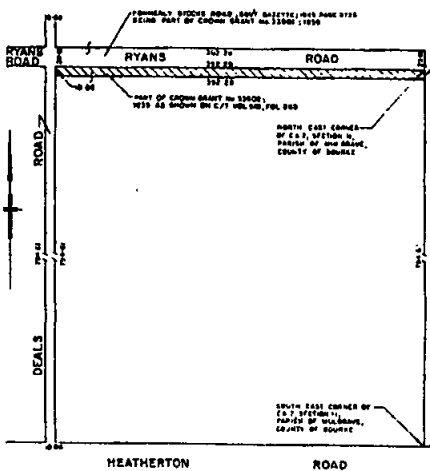

5426

INDICATES ROAD TO BE DISCONTINUED  
NOT WITHSTANDING SUCH DISCONTINUANCE, TELECOM AUSTRALIA SHALL CONTINUE TO HAVE AND POSSESS THE SAME RIGHT TITLE POWER AUTHORITY OR INTEREST IN OR IN RELATION TO THE WHOLE OF THE LAND SHOWN HATCHED WITH RESPECT TO ANY UNDERGROUND OR OVERHEAD CABLES LAID OR TO BE LAID ON THE SAID ROAD

CITY OF PRESTON  
Road Discontinuance

Pursuant to section 528 (2) of the *Local Government Act 1958*, the Council of the City of Preston at its Ordinary Meeting of Council held on 10 April 1989, resolved that the roads shown hatched on the plans below, be discontinued and sold by private treaty.

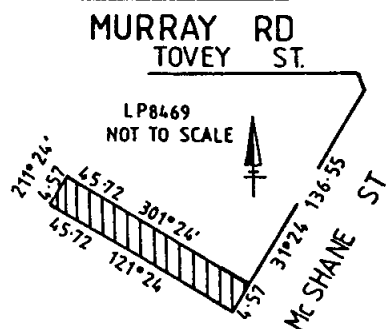
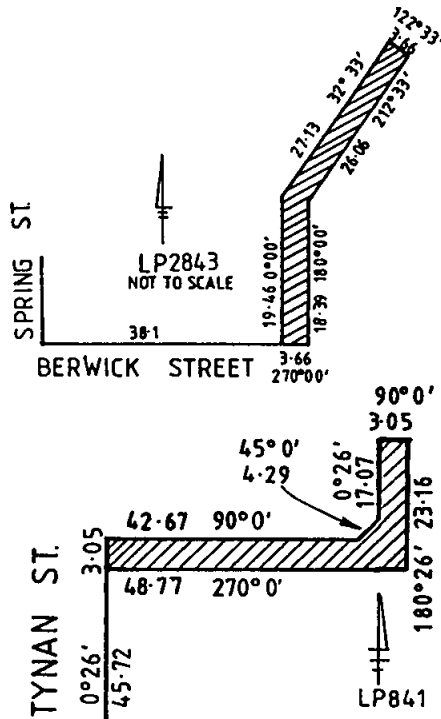
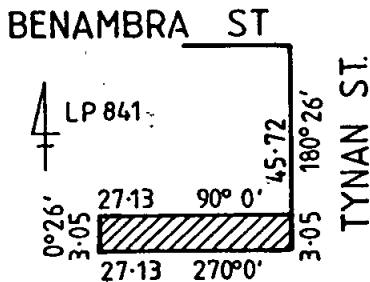

That notwithstanding such discontinuance the Council and the Melbourne and Metropolitan Board of Works shall continue to have and possess the same right, title, power, authority or interest in or in relation to the whole of the lands shown by hatching on the said plans as it had or possessed prior to such discontinuance with respect to or in connection with any drains or pipes laid or erected in on or over such lands for the purposes of drainage or sewerage.

D. O. McLEAN  
Chief Executive Officer

CITY OF SHEPPARTON  
Vesting of Reserves

At its meeting on 8 May 1989, the Council resolved pursuant to the provisions of section 569BA (1) of the *Local Government Act* 1958, as amended, to vest the Reserves noted hereunder in the Council.

Street Location	Reserve	Description Plan of Subdivision
Batman Avenue	Gerrard Reserve	124578
Longstaff Street	Wauchope Park	88771
Sutton Road	Wilson Park	137037 & 130534
Wright Avenue	Hanlon Park	99322
Pt. Broken River Drive Reserve	Ross-Edwards Reserve	137960
		115176
		99229
		124548
Reid Street	Alfred Kleinert Park	124548
Duncan Court	Duncan Coates Reserve	99020
		116966
Mills Street	Leembruggen Park	112750
Sarsfield Street	Billingham Park	71956
Oak Street	Bailey Park	27673
Wilmot Road	Tuttle Park	88028
Meaklim Street	Hillier Reserve	42796
		89790
Little Street	Little Park	44602
Swallow Street	O'Connor Park	20535
St. Andrews Road	Ross Dean Reserve	20156
		26121
Davis Court	Graham Park	125285
		133957
2-6 Asim Drive		205842
3 Sunray Court		204535
7 Wintersun Court		208050
Rear Ferguson Road	Reserve No. 1 and 2	201750

Dated 23 May 1989

I. L. GILBERT  
City Manager

5452

*Planning and Environment Act* 1987

CITY OF SALE

Notice of Amendment to a Planning Scheme

The Sale City Council has prepared Amendment No. L9 to the Sale Planning Scheme.

The amendment affects all land within the City of Sale.

The amendment proposes to change the Planning Scheme by replacing the existing advertising signs and advertisement provisions with new outdoor advertising controls.

The amendment can be inspected at the Sale Council Chambers, 82-88 Macalister Street, Sale, the office of the Department of Planning (Plan Inspection Section) Ground Floor, The Olderfleet Buildings, 477 Collins Street, Melbourne, and at the office of the Latrobe Regional Commission, 43 Grey Street, Traralgon.

Submissions about the amendment must be sent to the Town Clerk, City of Sale, Victoria, 3850, by 10 July 1989.

5494

J. H. LOW  
Town Clerk

CITY OF SOUTH BARWON  
Road Discontinuance

The Council of the City of South Barwon, having done all those things required by section 528 (2) of the *Local Government Act* 1958 to be done prior to the making of this Resolution and having formed the opinion that the road hereinafter mentioned is not reasonably required as a road for public use, the said Council of the City of South Barwon pursuant to the power given to it by section 528 (2) of the said Act at its Ordinary Meeting on 17 May 1989, resolved and directed:

- (a) That the portion of road reserve incorporated in No. 23 Peter Street, Grovedale, which road is shown hatched on the reference plan, shall be discontinued;
- (b) That the land in the said road shall vest in the municipality to be retained by it until it is sold by private treaty.

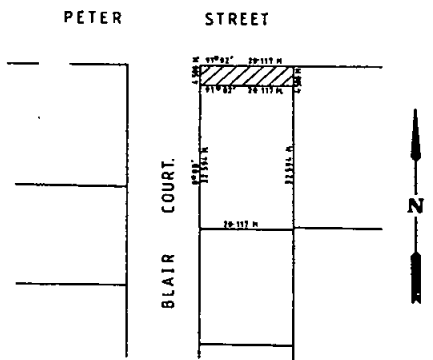

K. B. McDONALD  
Town Clerk

5411

*Planning and Environment Act 1987*  
**NOTICE OF AMENDMENT TO A  
PLANNING SCHEME**

The Warrnambool City Council has prepared Amendment No. L10 to the Warrnambool City Planning Scheme.

The amendment affects land at:

- (a) 65 Ocean Grove;
- (b) 5, 7, 9 and 11 Hider Street;
- (c) Crown Allotments 13 and 14, Part Crown Allotments 10 and 17, Section 66, Town of Warrnambool, i.e. Cramer Street end of the Racecourse;
- (d) Gibson Street.

The amendment proposes to change the Planning Scheme by:

- (a) Rezone to Residential 2;
- (b) Rezone to Public Purpose 7—Warrnambool Base Hospital;
- (c) Rezone to Residential 2;
- (d) Remove Proposed Road Widening.

The amendment can be inspected at The Town Planning Department, City Offices, City of Warrnambool, Liebig Street, Warrnambool 3280.

Submissions about the amendment must be sent to the Town Clerk, City of Warrnambool, P.O. Box 198, Warrnambool 3280 by 3 July 1989.  
Dated 26 May 1989

5419

V. G. ROBSON

*Planning and Environment Act 1987*  
**SHIRE OF AVON**

**Notice of Amendment to a Planning Scheme**

The Shire of Avon has prepared Amendment No. L3 to the Avon Planning Scheme, Local Section.

The amendment affects land east of Dargo.

The amendment proposes to change the Planning Scheme by rezoning land on the east side of the Dargo River located in the Parishes of Dargo and Quagmungie from Rural General Farming "A" zone to a reservation for a proposed road.

The amendment can be inspected at the Shire Offices, Shire of Avon, Tyers Street, Stratford, or the Ministry for Planning and Environment, Ground Floor, The Olderfleet Buildings, 477 Collins Street, Melbourne or the Ministry for Planning and Environment, Gippsland Regional Office, 1st Floor, Hotham La Trobe Building, 71 Hotham Street, Traralgon.

Submissions about the amendment must be sent to the Shire of Avon, P.O. Box 42, Stratford 3862 by 30 June 1989.

M. J. HART

Shire Engineer

5423

**SHIRE OF BULN BULN**  
**Road Discontinuance**

Pursuant to section 528 (2) of the *Local Government Act 1958*, the Council of the Shire of Buln Buln passed the following resolution at its Ordinary Meeting held on 20 January 1989.

This Council, being of the opinion that the part of the road shown hatched on the plan hereunder is not reasonably required as a road for public use, having consulted with relevant public statutory authorities, having published and given notice as required by section 528 (2) of the *Local Government Act 1958* hereby resolves and directs that: such part be discontinued on

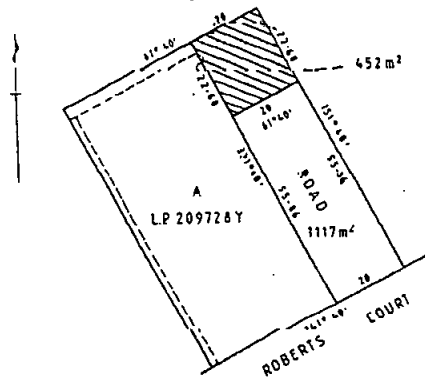

1328 G 21 31 May 1989

publication of this resolution in the *Government Gazette* and, the land so discontinued shall be retained by the Municipality for Municipal purposes.

K. A. PRETTY  
5448 Shire Secretary/Chief Executive

*Planning and Environment Act 1987*  
NOTICE OF AMENDMENT TO THE  
GEELONG REGIONAL PLANNING  
SCHEME

Amendment No. L27

The Shire of Bellarine has prepared Amendment No. L27 to the Geelong Regional Planning Scheme.

The amendment affects the municipal district of the Shire of Bellarine.

The amendment proposes to change the Local Section of the Planning Scheme by:

1. Including provisions to control the relocation of houses by requiring a permit.

The amendment can be inspected at Shire of Bellarine, Municipal Offices, Collins Street, Drysdale; Ministry for Planning and Environment, The Olderfleet Buildings, 477 Collins Street, Melbourne; Geelong Regional Commission, Fifth Floor, State Government Offices, Cnr Fenwick and Little Malop Streets, Geelong.

Submissions about the amendment must be sent to the Shire Manager, Shire of Bellarine, Collins Street, Drysdale 3222 by 3 July 1989.

Dated 11 May 1989

I. N. COUPER  
5398 Shire Manager, Shire of Bellarine

SHIRE OF BELLARINE

Pursuant to section 535 of the *Local Government Act 1958* the Council of the Shire of Bellarine resolved at a meeting held on 17 May 1989, that the name of the following streets or roads as set out hereunder be changed:

- (a) *Old name*—Douburg Street between Presidents Avenue and Eggleston Street.  
*New name*—Blackwood Place.
- (b) *Old name*—Douburg Street between Eggleston Street and the eastern boundaries of Nos. 71 and 72 Douburg Street.  
*New name*—Heath Close.
- (c) *Old name*—Douburg Street between Bramwell Street and the western boundaries of Nos. 73 and 74 Douburg Street.  
*New name*—Acacia Court.
- (d) *Old name*—Douburg Street between Bramwell Street and the eastern

*Victoria Government Gazette*

boundaries of Nos. 107 and 108 Douburg Street.

*New name*—Dubourg Court.

- (e) *Old name*—Lowe Street between Presidents Avenue and Eggleston Street.

*New name*—Lyrebird Street.

- (f) *Old name*—Lowe Street between Eggleston Street and the eastern boundaries of Nos. 71 and 76 Lowe Street.

*New name*—Teatree Close.

- (g) *Old name*—Lowe Street between Bramwell Street and the western boundaries of Nos. 73 and 78 Lowe Street.

*New name*—Sheoak Court.

- (h) *Old name*—Wilkinson Street between Presidents Avenue and Eggleston Street.

*New name*—Platypus Court.

- (i) *Old name*—Wilkinson Street between Eggleston Street and the eastern boundaries of Nos. 70 and 71 Wilkinson Street.

*New name*—Jabiru Close.

- (j) *Old name*—Wilkinson Street between Bramwell Street and the western boundaries of Nos. 72 and 73 Wilkinson Street.

*New name*—Lorikeet Close.

- (k) *Old name*—Wilkinson Street between Bramwell Street and Tuckfield Street.

*New name*—Wilkinson Court.

- (l) *Old name*—Watkin Street between Presidents Avenue and Eggleston Street.

*New name*—Crane Court.

- (m) *Old name*—Watkin Street between Eggleston Street and the eastern boundaries of Nos. 68 and 71 Watkin Street.

*New name*—Kurrajong Court.

- (n) *Old name*—Watkin Street and the western boundaries of Nos. 70 and 73 Watkin Street.

*New name*—Stingybark Place.

- (o) *Old name*—Wyatt Street between Bramwell Street and Tuckfield Street.

*New name*—Callistemon Court.

- (p) *Old name*—Bramwell Street between Madeley Street and Asbury Street East.

*New name*—Karri Close.

- (q) *Old name*—Bramwell Street between Asbury Street East and The Esplanade.

*New name*—Wedge Street.

*Locality*—Ocean Grove.

P. L. WIGNALL  
5397 Deputy Shire Manager/Shire Secretary

*Victoria Government Gazette*

*Planning and Environment Act 1987*

**NOTICE OF AMENDMENT TO A  
PLANNING SCHEME**

The Shire of Flinders has prepared Amendment No. L40 to the Flinders Planning Scheme.

The Amendment affects land at the recreation reserve on Lodged Plan No. 66731, Arthurs Seat Road, Arthurs Seat.

The Amendment proposes to change the Planning Scheme by rezoning the land to Special Urban Residential to enable its development and use for residential purposes.

The Amendment can be inspected at the Shire of Flinders, Boneo Road, Rosebud, 3939; Ministry for Planning and Environment, Regional Office, 33 High Street, Cranbourne, 3977; Ministry for Planning and Environment, The Olderfleet Buildings, 477 Collins Street, Melbourne, 3000.

Submissions about this Amendment must be sent to The Chief Executive, Shire of Flinders, P.O. Box 1000, Rosebud, 3939 by 4 July 1989.

Dated 31 May 1989

5425 IAN MORRIS, Manager  
Planning and Development

*Planning and Environment Act 1987*

**NOTICE OF AMENDMENT TO A  
PLANNING SCHEME**

The Shire of Hastings has prepared Amendment L14 to the Hastings Planning Scheme.

The amendment affects land bounded by Callanans Road, Bayview Road, Jeremiah's Road and the Hastings Bight as shown on the map below.

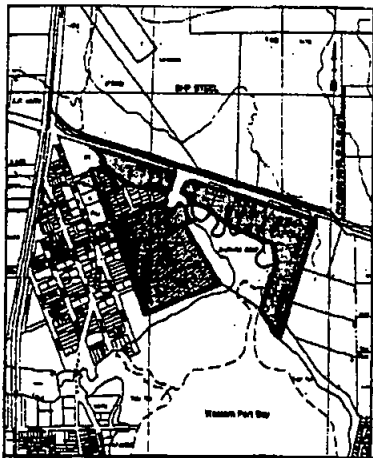

*G 21 31 May 1989 1329*

The amendment proposes to rezone land from Port Related Uses to Western Port General Industrial.

The amendment can be inspected at the Shire Offices, Marine Parade, Hastings; the Ministry for Planning and Environment, 33-39 High Street, Cranbourne; and the Ministry for Planning and Environment, The Olderfleet Buildings, 377 Collins Street, Melbourne.

Submissions about the amendment must be sent to the Manager—Planning and Development, Shire of Hastings, PO Box 55, Hastings, 3915 by 7 July 1989.

5477 R. J. WEBB, Manager  
Planning and Development

*Planning and Environment Act 1987*

**NOTICE OF AMENDMENT TO A  
PLANNING SCHEME**

The Shire of Hastings has prepared Amendment No. L18 to the Hastings Planning Scheme.

The amendment affects land included in the Special Use Airport Zone.

The amendment proposes to change the Use Table for the Special Use Airport Zone by including Warehouse and Transport Depot in Column 4 as a permissible use.

The amendment can be inspected at the Shire Offices, Marine Parade, Hastings; the Ministry for Planning and Environment, 33-39 High Street, Cranbourne; and the Ministry for Planning and Environment, The Olderfleet Buildings, 377 Collins Street, Melbourne.

Submissions about the amendment must be sent to the Manager, Planning and Development, Shire of Hastings, P.O. Box 55, Hastings 3915 by 7 July 1989.

5475 R. J. WEBB, Manager  
Planning and Development

*Planning and Environment Act 1987*

**NOTICE OF AMENDMENT TO A  
PLANNING SCHEME**

The Shire of Hastings has prepared Amendment No. L11 to the Hastings Planning Scheme.

The amendment affects land at 42 Victoria Street, Hastings.

The amendment proposes to introduce a site specific control to allow the land to be used and developed as an Office subject to the grant of a planning permit.

The amendment can be inspected at the Shire Offices, Marine Parade, Hastings; the Ministry for Planning and Environment, 33-39 High

1330 G 21 31 May 1989

Street, Cranbourne; and the Ministry for Planning and Environment. The Olderfleet Buildings, 377 Collins Street, Melbourne.

Submissions about the amendment can be sent to the Manager, Planning and Development, Shire of Hastings, P.O. Box 55, Hastings 3915 by 7 July 1989.

5476 R. J. WEBB, Manager  
Planning and Development

**SHIRE OF HEYTESBURY**

**Re-Naming of Road**

Notice is hereby given that the Council of the Shire of Heytesbury has resolved pursuant to section 535 (4) of the *Local Government Act 1958*, to rename that part of East West Road, Timboon, between Boundary Road and the Timboon-Peterborough Road, to be called Squibbs Road, Timboon.

5460 M. L. WHELAN  
Shire Manager

*Planning and Environment Act 1987*

**NOTICE OF AMENDMENT TO A  
PLANNING SCHEME**

The Shire of Lillydale has prepared Amendment No. L19 to the Lillydale Planning Scheme.

The amendment affects land locally known as "Yarraloch" being C.A's 131, Pt 132, Pt 133, 134, 134A, 133A, and 29A, Killara Road, Gruyere.

The amendment proposes to change the Planning Scheme by inserting a provision into the Local Section allowing subdivision of the property into 31 allotments.

The amendment can be inspected at Upper Yarra Valley and Dandenong Ranges Authority, John Street, Lilydale, Vic. 3140; Shire of Lillydale, Anderson Street, Lilydale, Vic. 3140; Ministry for Planning and Environment, The Olderfleet Buildings, 477 Collins Street, Melbourne, Vic. 3000.

Submissions about the amendment must be sent to the Shire of Lillydale, Shire Offices, Anderson Street, Lilydale, P.O. Box 105, Lilydale, by Friday, 30 June 1989.

5410 W. I. HEINE  
Chief Executive Officer

*Planning and Environment Act 1987*

**MELTON PLANNING SCHEME**

**Notice of Amendment  
Amendment L1**

The Shire of Melton has prepared this amendment to the Melton Planning Scheme.

The amendment affects land at Lot 1, LP128467 and Lots 1 and 2, LP128210 situated south of Tullidge Street, and east of Toolern Creek, Melton.

*Victoria Government Gazette*

The amendment proposes to change the Planning Scheme by rezoning the land from a Corridor A Zone to a Reserved Living Zone to enable the future residential subdivision and development of the land.

A copy of the amendment can be inspected, free of charge, during office hours at the Shire of Melton, Municipal Offices, Cnr High and Yuille Streets, Melton 3337; the Ministry for Planning and Environment, Ground Floor, The Olderfleet Buildings, 477 Collins Street, Melbourne 3000.

Submissions about the amendment must be sent to the Shire of Melton, Attention: Town Planning Section, P.O. Box 21, Melton 3337 by 3 July 1989.

5399 LINDSAY A. MERRITT  
Shire Manager

*Planning and Environment Act 1987*

**AMENDMENT TO THE LOCAL SECTION  
OF THE MILDURA SHIRE PLANNING  
SCHEME**

**Amendment L14**

At the meeting on 4 May 1989, Council determined to instigate amendment procedures to rezone from Rural A/Rural Highway to Urban, land described as Crown Allotments 2-5, Section 48, Block F, San Mateo Avenue, Mildura South, and Crown Allotments 11-15, Section 32, Block E, Ontario Avenue, Mildura South.

A copy of the amendment can be inspected at the Offices of the Shire of Mildura, Fifteenth Street, Irymple; Ministry for Planning and Environment, 7th Floor, 391 Hargreaves Street, Bendigo; Ministry for Planning and Environment, Ground Floor, The Olderfleet Buildings, 477 Collins Street, Melbourne.

Inspection is available during office hours and is free of charge.

Any persons affected by the amendment may set forth in writing any submission they may wish to make with respect to the amendment to the Planning Department, Shire of Mildura, P.O. Box 366, Irymple 3498, by 5 July 1989 and state whether they wish to be heard in respect of their submission.

5451 H. D. KIRBY  
Shire Engineer

*Planning and Environment Act 1987*

**NOTICE OF AMENDMENT TO A  
PLANNING SCHEME**

The Shire of Mornington has prepared Amendment No. L18 to the Mornington Planning Scheme.

The amendment affects land within the area bounded by Murray, Philip, Gordon and Barkly Streets, (with full length of Gordon Street included) and the property fronting Murray Street being a former factory site.

*Victoria Government Gazette*

The amendment proposes to change the Planning Scheme by the rezoning of the land fronting Gordon Street, to a new zone called "Low Intensity Service Industrial" and the old factory site fronting Murray Street to be rezoned from Industrial to High Density Residential, the same zoning as the land it abuts. Some additional definitions have been added into the scheme which are intended to apply only to the Low Intensity Service Industrial zone.

The amendment can be inspected at Shire of Mornington, Queens Street, Mornington, and Ministry for Planning and Environment, Ground Floor, 477 Collins Street, Melbourne.

Submissions about the amendment must be sent to Chief Executive Officer, by 30 June 1989, Shire of Mornington, P.O. Box 78, Mornington 3931.

Dated 31 May 1989

LYNTON D. SHEDDEN, Manager  
5424 Amenity Control

*Planning and Environment Act 1987*

NOTICE OF AMENDMENT TO A  
PLANNING SCHEME

The Shire of Rodney has prepared Amendment No. L20 to the Rodney Planning Scheme.

The amendment affects land at the corner of Dhurringile Road and Murton Road, Tatura. The land is described as being Lot 2, LP 123231, Pt C A 19, Parish of Toolamba.

The amendment proposes to change the Planning Scheme by rezoning the land from Rural 'B' to Rural 'C'.

The amendment can be inspected at the Shire of Rodney, Shire Offices, Casey Street, Tatura 3616; North East/Goulburn Region, Ministry for Planning and Environment, Astra House, Jack Hore Place, Wodonga 3690; Ministry for Planning and Environment, The Olderfleet Buildings, 477 Collins Street, Melbourne 3000.

Submissions about the amendment must be sent to the Shire of Rodney, Shire Offices, Casey Street, Tatura 3616 by Monday, 31 July 1989.

Dated 10 May 1989

TERRY W. ALFORD  
5391 Shire Engineer/Town Planner

PLANNING AND ENVIRONMENT ACT

Notice of Amendment to a Planning Scheme

The Shire of Pakenham has prepared Amendment No. L11 to the Pakenham Planning Scheme.

The amendment affects Part Lot 2, L.P. 20283 (No. 52) and Part Lot 3, L.P. 20283 (No. 50) John Street, Pakenham.

The amendment proposes to change the Planning Scheme by altering the planning control

G 21 31 May 1989 1331

from "Reserved Commercial" Zone to "Public Purposes I (Municipal Purposes)" reservation.

The amendment can be inspected at: Shire of Pakenham, Municipal Offices, Henty Way, Pakenham, Vic. 3810; Ministry of Planning and Environment, Southern and Westernport Region, 1st Floor, 33-39 High Street, Cranbourne, Vic. 3977; Ministry of Planning and Environment, Plan Inspection Section, The Olderfleet Buildings, 477 Collins Street, Melbourne, Vic. 3000.

Submissions about the amendment must be sent to Shire of Pakenham, P.O. Box 7, Pakenham, Vic. 3810 by 3 July 1989.

Dated 18 May 1989

RAY CANOBIE  
5418 Shire Secretary

SHIRE OF SHEPPARTON

Naming of Unnamed Road

Notice is hereby given that pursuant to section 535 (4) of the *Local Government Act 1958*, the Council of the Shire of Shepparton at its Ordinary Meeting of Council held on 22 May 1989, resolved to name the following unnamed road:

*Old name*—Unnamed Road.

*New name*—Phillips Road.

*Location*—South of Crown Allotment 40A, Parish of Congupna, County of Moira.

I. W. MARTIN  
5407 Shire Secretary

SHIRE OF WARRACKNABEAL

ASSIGNING OF ROAD NAME

Notice is hereby given that pursuant to section 535 (4A) of the *Local Government Act 1958* (as amended) that the Council of the Shire of Warracknabeal on 19 May 1989 resolved that the name of an unnamed Government Road Reserve in the North East Riding, north of the Borung Highway to the Lah Angle Road adjoining C.A.'s 35A, 109, 110 and 121, Parish of Bangerang be assigned as follows:

*Name*: Pietsch Road.

K. V. SHADE  
5486 Shire Secretary

SHIRE OF WOORAYL

Road Discontinuance

That whereas the Council of the Shire of Woorayl—

1. is of the opinion that the right of way on the southern boundary of 20 Atkinson Avenue and eastern boundary of 20 and 22 Atkinson Avenue, Venus Bay which is shown by hatching on the plan at the foot hereof is not reasonably required as a road for public use;

1332 G 21 31 May 1989

2. has consulted with the public statutory corporations referred to in section 528 (2) (e);

3. has not less than one month before the date of this meeting published a public notice in the *Star* and *Sentinel Times* newspapers and given written notice to the owners and occupiers of the land abutting or immediately adjacent to the said road in accordance with section 528 (2) (a) (iii).

Now the Council does hereby direct—

- (a) that the said road which is shown by hatching on the plan herewith shall be discontinued upon publication of this resolution in the *Government Gazette*;
- (b) that notwithstanding such discontinuance the Shire of Woorayl shall continue to have and possess the same right title power authority or interest in or in relation to the whole of the land shown by hatching on the said plan as it had or possessed prior to such discontinuance with respect to or in connection with any drains or pipes laid or erected in on or over such land for the purposes of drainage or sewerage;
- (c) that subject to any such right title power authority or interest the land in the said road shall vest in the municipality until it is sold by private treaty.

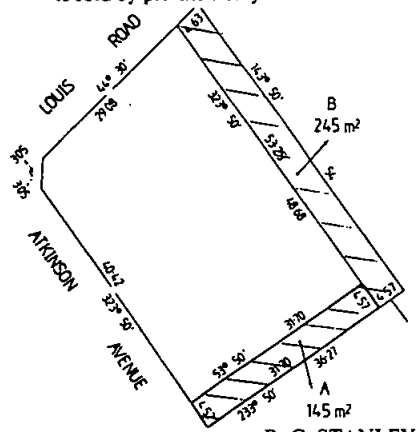

R. G. STANLEY  
Shire Secretary

5456

#### NOTICE OF AMENDMENT TO A PLANNING SCHEME

The Shire of Woorayl has prepared Amendment No. L17 to the Woorayl Planning Scheme.

The Amendment introduces revised provisions to Residential zones within the Woorayl Planning Scheme. These provisions have been formulated in response to the Residential Development

#### Victoria Government Gazette

Provisions formulated by the Task Force appointed to the Minister for Planning and Environment.

The Amendment introduces the following:

Dual Occupancy (Leongatha Township only).

A maximum building height of 8.0 metres (whole Shire).

Revised setback requirements for buildings in Residential A and Residential Development areas (Leongatha Township only).

Revised minimum requirements for the subdivision of land in the Residential A zone (Leongatha Township only).

The introduction of Zero Lot Line provisions, i.e. building on title boundaries (Leongatha Township only).

Extension of maximum size of outbuildings from 60 square metres to 80 square metres in Residential zones (whole Shire).

The amendment can be inspected at Shire of Woorayl, 9 Smith Street, Leongatha; Ministry for Planning and Environment, 33-39 High Street, Cranbourne; Ministry for Planning and Environment, 477 Collins Street, Melbourne.

Submissions about the Amendment must be sent to the Shire of Woorayl, 9 Smith Street, Leongatha by 3 July 1989.

T. J. LUDEMAN

Town Planner

5406

#### SHIRE OF YARRAWONGA

##### By-Law No. 67

Notice is hereby given that pursuant to the powers conferred by the *Local Government Act 1958*, the Council of Shire of Yarrawonga has made a By-Law numbered 67 for the purpose of:

1. Repealing By-Law No. 65.
2. Prohibiting or regulating the placing of caravans on private property.
3. Prohibiting or regulating camping on roads.
4. Prohibiting or regulating the establishment of camps on private property.

The resolution passing the By-Law was agreed to by the Council of the Shire of Yarrawonga on 29 March 1989 and confirmed on 10 May 1989.

A copy of the By-Law is open for inspection free of charge at the Office of the Council of the Shire of Yarrawonga, Shire Hall, Belmore Street, Yarrawonga.

G. J. EMONSON

5482 Chief Executive Officer/Shire Secretary

The Goroke Bowling Club (Inc) hereby wish to apply for a further 21 years lease on allotment 9B, Parish of Goroke, in the Shire of Koorwee, for the purpose of sport and recreation. 5390



NOTICE OF COVENANT

Sec. 3A Victorian Conservation Trust Act

Abigrove Pty Ltd, Donald William Hossack and Dorothy Elizabeth Joan Hossack propose to enter into a Covenant with the Victorian Conservation Trust of 250 Victoria Parade, East Melbourne with regard to approximately 25 ha of land situated off the Mount Eirene Road, Gembrook being Allotments 105, 106 and 107, Parish of Gembrook, Shire of Pakenham for the purpose of:

*Protecting the native trees, wildlife and other special features by regulating:*

- (a) The introduction of flora and fauna not indigenous to the area;
- (b) The grazing of stock;
- (c) The keeping of domestic animals;
- (d) The erection of buildings and subdivision;
- (e) Other potential developments and changes on the land in order to ensure its conservation.

Submissions with respect to the proposed Covenant may be made within one month of the publication of this notice in the *Government Gazette* to the Minister for Planning and Environment, (att. Manager, Environment and Planning) Box 2240T, G.P.O Melbourne 3001. Enquiries may be directed to the Victorian Conservation Trust, tel. (03) 412 4661. 5388

SUNBURY WATER BOARD

Notice is hereby given that the above Authority intends to construct trunk sewers and related works in the area known as Blind Creek from Kerri Court to Strathearn Glen Estate to serve properties situated in the whole or parts of the areas hereinafter described in the Sunbury Sewerage District.

Maps and plans showing the works to be constructed are open for inspection at the Board's office, between the hours of 9.00 a.m. and 5.00 p.m. Monday to Friday.

The area referred to above comprises the area generally bounded by Blind Creek and Stewarts Lane, Sunbury.

JOHN M. KELLY  
Secretary

5487

SUNBURY WATER BOARD

Notice is hereby given that the above Authority intends to construct trunk sewers and related works in the area known as Kismet Creek from Aldridge Drive to Phillips Drive to serve properties situated in the whole or parts of the areas hereinafter described in the Sunbury Sewerage District.

Maps and plans showing the works to be constructed are open for inspection at the Board's

G 21 31 May 1989 1333

office, between the hours of 9.00 a.m. and 5.00 p.m. Monday to Friday.

The area referred to above comprises the area north of Riddell Road between Spavin Drive and Bundanoon Park.

JOHN M. KELLY  
Secretary

5488

Water Act 1958

MORNINGTON PENINSULA AND DISTRICT WATER BOARD

Mornington Peninsula Urban District  
Gazettal Notice No. 4

Notice to owners of tenements in the undermentioned streets in the Mornington Peninsula Urban District and the Private Streets, Lanes, Courts and Alleys opening thereto:

Street	Section
	Bunyip
A'beckett Road	From end of existing main opposite lot 1 to a point opposite lot 13 about 100 metres north easterly.
	Carrum Downs
Rangeview Drive	From end of existing main opposite lots 99 and 100 to a point opposite lots 153 and 212 about 220 metres northerly.
Louise Court	Full length.
Alice Court	Full length.
Lyrebird Drive	From end of existing main opposite lot 1251 to a point opposite lots 1266 and about 210 metres north easterly.
Tattler Street	From Lyrebird Drive to a point opposite lots 1356 and 1357 about 90 metres easterly.
Pardalotte Avenue	From Tattler Street to Swift Court.
Swift Court	Full length.
Pinewood Drive	From a point opposite lot 38 to a point opposite lot 10 about 95 metres northerly.
Manna Gum Court	Full length.
Boronia Court	Full length.
Toiram Crescent	From Lesdon Avenue to a point opposite lot 350 about 310 metres westerly.
Valda Court	Full length.
Miller Court	Full length.

1334 G 21 31 May 1989

South Anderson Full length.  
Court

Kingsvale Court Full length.  
Cranbourne

Hoystead Avenue From end of existing main  
opposite lots 126 and 127  
to a point opposite lot 11  
and municipal reserve  
about 225 metres easterly.

Woodbine Road From Hoystead Avenue  
to Thompson Road.

Candytuft Court Full length.

Blueberry Close Full length

Clairmont Avenue From end of existing main  
opposite lots 2 and 179 to  
a point opposite lots 28  
and 29 about 155 metres  
northerly.

Darcy Court Full length.

Janie-Maree Place Full length.

Blanch Close Full length.

Flinders Parade East Crib Point  
From end of existing main  
opposite lot 45 to Center  
Avenue about 125 metres  
northerly.

Center Avenue From Flinders Parade  
East to Messines Road  
about 405 metres  
westerly.

Hamilton Street From end of existing main  
opposite lot 263 and  
CP164500 to Urquhart  
Crescent about 595 metres  
easterly.

Callas Street Dromana  
From end of existing main  
opposite lot 114 and 116  
to a point opposite lot 115  
about 25 metres easterly.

Eddystone Street McCrae  
From end of existing main  
at corner of Eddystone  
and Gellibrand Streets to  
a point opposite lot 2  
about 40 metres south  
westerly.

Merricks Beach Road Merricks  
From end of existing main  
opposite lot 60 to a point  
opposite lot 44 about 30  
metres southerly.

Bentons Road Mornington  
From end of existing main  
opposite lots P1 17 and 3  
to a point opposite lots 4

Victoria Government Gazette

and 6 about 560 metres  
easterly.

Archer Drive From Carbine Way to a  
point opposite and lots 82  
and 31 about 650 metres  
north and westerly.

Carbine Way From Racecourse Road to  
a point opposite lot 9  
about 520 metres  
westerly.

Mount Martha

Craigie Road From end of existing main  
opposite lots 6 and 1 to a  
point opposite lots 4 and  
part 26 about 1010 metres  
south easterly.

Seppelt Avenue From Uralla Road to a  
point opposite lot 1 about  
335 metres north easterly.

Uralla Road From Bay Road to  
Seppelt Avenue about 400  
metres northerly.

Latrobe Drive From Bay Road to a point  
opposite lot 29 about 160  
metres north westerly.

Village Close Full length.

Pakenham

Bluegrass Crescent From Barrington Drive to  
a point opposite lots 243  
and 237 about 335 metres  
westerly.

Barrington Drive From end of existing main  
opposite lot 202 to a point  
opposite lot 207 about 90  
metre northerly.

Bridle Place From Bluegrass Crescent  
to a point opposite lot 284  
about 40 metres northerly.

Stirrup Court Full length.

Purton Road From end of existing main  
opposite lots 16 and 18 to  
Mulcahy Road about 175  
metres northerly.

Mulcahy Road From Purton Road to a  
point opposite municipal  
reserve about 190 metres  
westerly.

Gerrard Court Full length.

Rosebud

Curlew Drive From end of existing main  
opposite lots 51 and 70 to  
a point opposite lot 69  
about 185 metres  
southerly.

Sanderling Court Full length.

Dotterel Court Full length.

Victoria Government Gazette

Safety Beach

Rymer Avenue From end of existing main opposite lot 720 to a point opposite lot 719 about 30 metres southerly.

Somerville

Chesterfield Road From end of existing main opposite lot 49 to a point opposite lot 71 about 150 metres westerly.

Blackwood Rise Full length.

The main pipe in the said streets being laid down, the owners of all tenements situated as above are hereby required, on or before 1 July 1989 to cause proper pipes and stop cocks to be laid so as to supply water within such tenements from the main pipe.

Dated at Frankston

J. O. WILLIAMS, Secretary  
5441 Mornington and District Water Board

Sixth Schedule  
MORNINGTON PENINSULA AND  
DISTRICT WATER BOARD

General Notice

Declaration of Sewerage Area

The abovementioned Board having made provision for carrying off the sewerage from each and every property which, or any part of which, is within the Sewerage Area hereinafter described, doth hereby declare that on or after 1 July 1989 each and every property which, or any part of which, is within the said Sewerage Area shall be deemed to be a seweraged property within the meaning of the *Sewerage Districts Act* 1958.

The boundaries of the Sewerage areas hereinafter referred to are:

CITY OF FRANKSTON

*Sewerage Area No. 379*

The boundaries of all that piece of land comprising Lot Nos. 148 to 174 inclusive on Lodged Plan of Subdivision No. 211219 generally abutting Hunt Drive, Valerie Court, Seaford.

SHIRE OF FLINDERS

*Sewerage Area No. 131*

The boundaries of all that piece of land comprising Lodged Plans of Subdivision Nos. 208691 and 208692 generally abutting Boneo Road, Hiscock Road, Rosebud West.

SHIRE OF CRANBOURNE

*Sewerage Area No. 188*

The boundaries of all that piece of land comprising Lodged Plans of Subdivision Nos. 211889 and 211890 generally abutting Bianco Court, Lawless Drive, Cranbourne North.

G 21 31 May 1989 1335

*Sewerage Area No. 189*

The boundaries of all that piece of land comprising Lodged Plan of Subdivision No. 211840 generally abutting Chandos Place, Meridian Court, Langwarrin.

MORNINGTON SEWERAGE DISTRICT

*Sewerage Area No. 205*

The boundaries of all that piece of land comprising Lot Nos. 6 to 11 inclusive on Lodged Plan of Subdivision No. 81954, Lot Nos. 18, 22 to 28 inclusive on Lodged Plan of Subdivision No. 17880 generally abutting John Rowell Lane, Kalimna Drive, Silvan Grove, Waratah Avenue, Mornington.

*Sewerage Area No. 206*

The boundaries of all that piece of land comprising the odd street numbers 1 to 55 inclusive on the east side of Caraar Creek Lane, Mornington.

By Order of the said Water Board.

J. K. BUCHANAN  
Chairperson

J. O. WILLIAMS  
Secretary

5442

SWAN HILL WATER BOARD

General Notice

Declaration of Sewered Areas in Swan Hill

The Swan Hill Water Board having made provision for carrying off the sewage from each and every property which or any part of which is within the sewerage area hereinafter described doth hereby declare that on and after 1 July 1989 each and every property which or any part of which is within the said sewerage area shall be declared to be a seweraged property within the meaning of the *Sewerage Districts Act* 1958.

The sewerage areas hereinbefore referred to are:

*Sewerage Area 60A*

Lots 28, 29, 30, 31—C.A. 7

Lot 53—C.A. 7

By Order of the Swan Hill Water Board.

D. J. WILKINS, Chairman

G. J. MENNIE, Secretary

5409

SWAN HILL WATER BOARD

Notice to owners of tenements in the streets and the private streets, lanes, courts and alleys opening thereto.

The main pipe in the said street being laid down the owners of all tenements situated as under are hereby required on or before 1 July 1989, to cause a proper pipe and stop cock to be laid so as to supply water within such tenement from the main pipe.

1336 G 21 31 May 1989

*Swan Hill Urban District*  
Area No. 76—Poole Boulevard  
Area No. 77—Parkview Drive  
Area No. 78—Shepherd Road

G. J. MENNIE  
Secretary

5408  
Notice of Application for a Licence to divert water from the Goulburn River at Eildon to part Crown Allotment 14 Allotment 4, Section LP146229, Parish of Eildon.

I hereby give notice of an application for a licence empowering me to divert water for a term of 15 years to the extent of 100 megalitres per annum at a maximum rate of 4 megalitres per day of 24 hours for the irrigation of 16 hectares and to occupy certain Crown Lands for diversion works.

Any objection to the granting of this application must be forwarded in writing to reach the Manager Business Services, Rural Water Commission, 33 Casey Street, Tatura, 3616 before 23 June 1989 being thirty days from the publication of this notice.

GREGORY RAYMOND LUCAS, P.O. Box  
32, Eildon, Victoria, 3713 5386

Notice of Application for a Licence to divert water from the Goulburn River at Eildon to part Crown Allotment 14 and 15 Allotment 2. Section LP208098M, Parish of Eildon.

I hereby give notice of an application for a licence empowering me to divert water for a term of 15 years to the extent of 12 megalitres per annum at a maximum rate of 0.5 megalitres per day of 24 hours for the irrigation of 6 hectares and to occupy certain Crown lands for diversion works.

Any objection to the granting of this application must be forwarded in writing to reach the Manager Business Services, Rural Water Commission, 33 Casey Street, Tatura, 3616 before 23 June 1989 being thirty days from the publication of this notice.

GREGORY RAYMOND LUCAS, P.O. Box  
32, Eildon, Victoria, 3713 5387

#### SECOND SCHEDULE

Notice of Application for a Licence to divert water from the Loddon River at Serpentine to Allotment 7, 6, 9, 9A, 1, 2, 4, 5, 1A, 1B Section 17, 13, 11, 10, Parish of Yarrayne.

I hereby give notice of an application for a licence empowering me to divert water for a term of 15 years to the extent of 200 megalitres per annum at a maximum rate of 30 megalitres per day of 24 hours for the irrigation of 20-454 hectares and to occupy certain Crown lands for diversion works.

*Victoria Government Gazette*

Any objection to the granting of this application must be forwarded in writing to reach the Regional Manager, Loddon-Torrumbarry, Rural Water Commission, P.O. Box 264, Kerang, 3579, before 22 June 1989 being thirty days from the publication of this notice.

CHARLTON FEEDLOT PTY. LTD.,  
Serpentine Farm, P.O. Box 29, Serpentine,  
Victoria 3517 5396

Note: This notice supersedes that made on 22 October 1988. Note changes to Allotments, and Sections.

#### SECOND SCHEDULE

Notice of application for a licence to divert water from the Broken River, at Kialla, to allotments Pts 66A, 66B, 67, Parish of Kialla.

I hereby give notice of an application for a licence empowering me to divert water for a term of 15 years to the extent of 50 megalitres per annum at a maximum rate of 4 megalitres per day of 24 hours for the Irrigation of 14 ha and to occupy certain Crown lands for diversion works.

Any objection to the granting of this application must be forwarded in writing to reach the Manager Business Services, Rural Water Commission, 33 Casey Street, Tatura 3616.

KEVIN JAMES THORN, RMB 5895,  
Shepparton 3630 5416

#### SECOND SCHEDULE

Notice of application for a licence to divert water from the Goulburn River, at Arcadia Downs, to allotments Pt 60 and 74, Parish of Kialla.

I hereby give notice of an application for a licence empowering me to divert water for a term of 15 years to the extent of 3 megalitres per annum at a maximum rate of 0.02 megalitres per day of 24 hours for the Irrigation (0.4371 ha) and to occupy certain Crown lands for diversion works.

Any objection to the granting of this application must be forwarded in writing to reach the Manager Business Services, Rural Water Commission, 33 Casey Street, Tatura 3616.

JOHN and MARILYN YOUNG, 9 St  
Andrews Rd, Shepparton 5413

#### SECOND SCHEDULE

Notice of application to divert water from the Goulburn River, Kanyapella, to allotments 154 and 154A, Parish of Kanyapella.

I hereby give notice of an application for a licence empowering me to divert water for a term of 15 years to the extent of 305 megalitres per annum at a maximum rate of 12 megalitres per day of 24 hours for the 51 ha Pasture Irrigation and to occupy certain Crown lands for diversion works.

Any objection to the granting of this application must be forwarded in writing to reach the Manager Business Services, Rural Water Commission, 33 Casey Street, Tatura 3616.

LEONARD M. H. BENNETT, 120 Bridge Street, Bendigo 5414

SECOND SCHEDULE

Notice of application for a licence to divert water from the Goulburn River, at Kanyapella, to Allotments 7, 8, 9, 10, 11 and 11A, Section C, Parish of Kanyapella.

I hereby give notice of an application for a licence empowering me to divert water for a term of fifteen (15) years to the extent of 259.0 megalitres at a maximum rate of 12 megalitres per day of 24 hours for the irrigation of 200 ha of cereal, pasture and lucerne and to occupy certain Crown lands for diversion works.

Any objection to the granting of this application must be forwarded in writing to reach the Manager Business Services, Rural Water Commission, 33 Casey Street, Tatura 3616 before Friday, 23 June 1989 being thirty days from the publication of this notice.

DANIEL STELMACH on behalf of R. G. & D. STELMACH, 'Kalamunda', P.O. Box 422, Echuca 3564 5415

SECOND SCHEDULE

Notice of application to divert water from the Goulburn River, at Molesworth, to allotments 23 and 23A, Parish of Molesworth.

I hereby give notice of an application for a licence empowering me to divert water for a term of 15 years to the extent of 74 megalitres per annum at a maximum rate of 3.7 megalitres per day of 24 hours for irrigation and to occupy certain Crown lands for diversion works.

Any objection to the granting of this application must be forwarded in writing to reach the Manager Business Services, Rural Water Commission, 33 Casey Street, Tatura 3616, before 23 June 1989 being thirty days from the publication of this notice.

DAIWA BUILDING COMPANY LTD, "Nar-Darak", Dropmore Road, Molesworth, Victoria 3718, Telephone (057) 97 6270 5416

SECOND SCHEDULE

Notice of application for a licence to divert water from the Goulburn River at Kialla to allotment 49A.

I hereby give notice of an application for a licence empowering me to divert water for a term of 15 years to the extent of 74 megalitres per annum at a maximum rate of 5 megalitres per day of 24 hours for the irrigation of 12.3 hectares and to occupy certain Crown lands for diversion works.

Any objection to the granting of this application must be forwarded in writing to reach the Manager Business Services, Rural Water Commission, 33 Casey Street, Tatura 3616.

R. A. & J. P. PINNER, Box 943, Shepparton, 3630 5434

SECOND SCHEDULE

Notice of application for a licence to divert water from the Goulburn River, at Echuca Village to allotment 6C, section A, Parish of Kanyapella.

I hereby give notice of an application for a licence empowering me to divert water for a term of 15 years to the extent of 37 megalitres per annum at a maximum rate of 10 megalitres per day of 24 hours for the irrigation of six hectares of pasture and to occupy certain Crown lands for diversion works.

Any objection to the granting of this application must be forwarded in writing to reach the Manager Business Services, Rural Water Commission, 33 Casey Street, Tatura 3616.

RAYMOND WEIR RUMBLE, P.O. Box 168, Echuca, 3564 5435

SECOND SCHEDULE

Notice of application for a licence to divert water from the Goulburn River at Echuca Village to allotment 4A, section A, Parish of Kanyapella.

I hereby give notice of an application for a licence empowering me to divert water for a term of 15 years to the extent of 187.2 megalitres per annum at a maximum rate of 10 megalitres per day of 24 hours for the irrigation of 31.2 hectares of pasture and to occupy certain Crown Lands for diversion works.

Any objection to the granting of this application must be forwarded in writing to reach the Manager Business Services, Rural Water Commission, 33 Casey Street, Tatura, 3616.

GERALD LEO McDONELL, ANTOINETTE EVELINE McDONELL, Shepparton Road, Echuca, 3564 5436

SECOND SCHEDULE

Notice of application for a licence to divert water from the Goulburn River, at Murchison East to allotments 93 A, B, C, D, E and F, Parish of Arcadia.

I hereby give notice of an application for a licence empowering me to divert water for a term of 15 years to the extent of 25 megalitres per annum at a maximum rate of 7 megalitres per day of 24 hours for the irrigation 4.1 hectares and to occupy certain Crown lands for diversion works.

Any objection to the granting of this application must be forwarded in writing to reach

1338 G 21 31 May 1989

the Manager Business Services, Rural Water Commission, 33 Casey Street, Tatura, 3616.

ROBERT B. CLEMENTS for W. H. ARNLEYSIDE P/L, McArthurs Road, South Morang, 3752 5438

**SECOND SCHEDULE**

Notice of application for a licence to divert water from the Goulburn River at Scobie Road, Wyuna West to allotment 26 (Lot 1 and Lot 2), Parish of Wyuna.

I hereby give notice of an application for a licence empowering me to divert water for a term of 15 years to the extent of 100 megalitres per annum at a maximum rate of 12 megalitres per day of 24 hours for the irrigation (40 hectares) and to occupy certain Crown lands for diversion works.

Any objection to the granting of this application must be forwarded in writing to reach the Manager Business Services, Rural Water Commission, 33 Casey Street, Tatura 3616 before 24 June 1989 being thirty days from the publication of this notice.

J. S. & V. L. MILLER, R.M.B. 1745, Tongala, 3621 5457

**SECOND SCHEDULE**

Notice of application for a licence to divert water from the Goulburn River, at Kialla to allotment Lot 5 LP 93826 Part of 77A, Parish of Kialla.

I hereby give notice of an application for a licence empowering me to divert water for a term of 15 years to the extent of 27 megalitres per annum at a maximum rate of 1.25 megalitres per day of 24 hours for the irrigation of pasture 4.2 hectares and to occupy certain Crown lands for diversion works.

Any objection to the granting of this application must be forwarded in writing to reach the Manager Business Services, Rural Water Commission, 33 Casey Street, Tatura 3616 before 24 June 1989 being thirty days from the publication of this notice.

MARGARET J. McLEOD, P.O. Box 1323, Shepparton, Vic. 5458

**SECOND SCHEDULE**

Notice of application for a licence to divert water from the Goulburn River at Chateau Tahbilk Anabranche to allotment 28B, 26A, Parish of Tabilk.

I hereby give notice of an application for a licence empowering me to divert water for a term of 15 years to the extent of 111 megalitres per annum at a maximum rate of megalitres per day of 24 hours for the irrigation of 40 hectares and to occupy certain Crown lands for diversion works.

*Victoria Government Gazette*

Any objection to the granting of this application must be forwarded in writing to reach the Manager Business Services, Rural Water Commission, 33 Casey Street, Tatura 3616 before 24 June 1989 being thirty days from the publication of this notice.

TIMOTHY and CLARE PURBRICK, Terragong, Tabilk, Vic. 3607 5459

**SECOND SCHEDULE**

Notice of application for a licence to divert water from the Goulburn River at Wyuna to Allotment 66 and 66A, Parish of Wyuna

I hereby give notice of an application for a licence empowering me to divert water for a term of 15 years to the extent of 70 megalitres per annum at a maximum rate of 12 megalitres per day of 24 hours for the irrigation of 12 hectares and to occupy certain Crown lands for diversion works.

Any objection to the granting of this application must be forwarded in writing to reach the Manager Business Services, Rural Water Commission, 33 Casey Street, Tatura, 3616, before 26 June 1989 being thirty days from the publication of this notice.

GEOFFREY FRANK & LYNETTE CLAIRE HALLETT, "Wyuna Downs" RMB 1395, Wyuna 3620 5478

**SECOND SCHEDULE**

Notice of application for a licence to divert water from Broken River at Mungerie Cosgrove South to Allotments PT8, 9, Parish of Pine Lodge

I hereby give notice of an application for a licence empowering me to divert water for a term of 15 years to the extent of 134 megalitres per annum at a maximum rate of 6 megalitres per day of 24 hours for the irrigation of 60 hectares and to occupy certain Crown lands for diversion works.

Any objection to the granting of this application must be forwarded in writing to reach the Manager Business Services, Rural Water Commission, 33 Casey Street, Tatura, 3616, before 26 June 1989 being thirty days from the publication of this notice.

JEREMY MICHAEL JAMES & FELICITY ANNE GAYLARD, Mungerie RMB 1760, Shepparton 5479

**SECOND SCHEDULE**

Notice of application for a licence to divert water from Goulburn River at Kanyapella to Allotment 158, Section B, Parish of Kanyapella.

I hereby give notice of an application for a licence empowering me to divert water for a term of 15 years to the extent of 45 megalitres per annum at a maximum rate of 10 megalitres per day of 24 hours for the irrigation of 10 hectares

*Victoria Government Gazette*

of pasture and to occupy certain Crown lands for diversion works.

Any objection to the granting of this application must be forwarded in writing to reach the Manager Business Services, Rural Water Commission, 33 Casey Street, Tatura, 3616, before 26 June 1989 being thirty days from the publication of this notice.

BRIAN FRANCIS QUINN, 82 Bowen Street,  
Echuca, 3546 5480

**NOTICE OF DISSOLUTION**

Notice is hereby given that the partnership heretofore subsisting between John Downes and Marianne Downes and Debabriya Bhattacharya and Alana Bhattacharya carrying on business as Restaurateurs at 15 Ormond Road, Elwood under the name of Cafe Tarrango has been dissolved as from 16 December 1988 so far as concerns the said John Downes and Marianne Downes who retire from the partnership.

JOHN DOWNES

MARIANNE DOWNES

DEBABRIYA BHATTACHARYA

ALANA BHATTACHARYA 5497

In the matter of the Companies (Victoria) Code and in the matter of Leo Monti's Bus Services Pty. Ltd. (In Liquidation)

Notice is hereby given that pursuant to section 411 of the Companies (Victoria) Code, the final meeting of the members of the company will be held at Cnr. Mundy and Hopetoun Streets, Bendigo, on Monday, 3 July 1989 at 2.00 p.m. for the purpose of laying before the meeting the account of the winding up and any explanation thereof.

Dated 26 May 1989

T. C. REID, liquidator, Leo Monti's Bus Services Pty. Ltd. (In Liquidation) 5496

Companies (Victoria) Code

KENNER UPHOLSTERING CO.  
PROPRIETARY LIMITED

Notice of Voluntary Liquidation—Section 392  
(2)

At a general meeting of the abovenamed company, duly convened and held at 19 Carpenter Street, Brighton on 20 December 1988, the following special resolution was passed:

That the company be wound up as a Members Voluntary Liquidation and that the assets of the company may be distributed in whole or in part to the members in specie should the liquidator so desire.

Dated 29 May 1989

B. R. S. COMFORT, P.O. Box 2100, North Brighton 5474

*G 21 31 May 1989 1339*

In the Supreme Court of Victoria at Melbourne, 1989 Co. No. 432—In the matter of the Companies (Victoria) Code: and in the matter of Unidata Australasia Pty. Ltd.—Advertisement of Application for Winding Up

Notice is hereby given that an application for the winding up of the abovenamed company by the Supreme Court was on 12 May 1989 filed by Lucas Seater Design Pty. Ltd., a creditor of the abovenamed company. The application is to be heard before the Seventh Court in the Supreme Court, Law Courts, Lonsdale Street, Melbourne at 10.30 a.m. on 28 June 1989.

The Liquidator whose appointment is sought is David Carl Christensen of the firm of Coopers and Lybrand, chartered accountants, of 28th Floor, 385 Bourke Street, Melbourne in the State of Victoria.

Any creditor or contributory of the company desiring to support or oppose the making of an order on the application may appear at the time of the hearing by himself or his counsel for that purpose. A copy of the application will be furnished by the undersigned to any creditor or contributor of the company requiring it on payment of the regulated fee.

The Applicant's address is 34 Cambridge Street, Collingwood in the State of Victoria.

The Applicant's solicitors are E. L. Moran & Co., of 27 Ringwood Street, Richmond in the State of Victoria.

E. L. MORAN & CO., as agents for Lucas Seater Design Pty. Ltd.

Note: Any person who intends to appear on the hearing of the application must serve or send by post to the abovenamed E. L. Moran & Co. notice in writing of his intention so to do. The notice must state the name and address of the person or, if a firm, the name and address of the firm, and must be signed by the person or firm or his or their solicitor (if any), and must be served or, if posted, must be sent by post in sufficient time to be received not later than 4 p.m. on 27 June 1989. 5495

Companies (Victoria) Code

FREEMAN INVESTMENTS PTY. LTD. (In Liquidation)

Notice is hereby given in accordance with section 392 (2) of the Companies (Victoria) Code that at an extraordinary general meeting of the members of the abovementioned company, duly convened and held on 23 May 1989 the following special resolution was passed:

That the Company be wound up voluntarily.

Dated 23 May 1989

P. L. WHARTON  
Secretary

5437

1340 G 21 31 May 1989

G.H.L. HOLDINGS PTY LIMITED—(in voluntary liquidation)

Notice is given that at a general meeting of shareholders held on 11 May 1989, it was resolved that the company be placed into members voluntary liquidation and that A. H. Abbott of 353 New South Heads Road, Double Bay, be appointed liquidator.  
Dated 11 May 1989

ADRIAN H. ABBOTT  
Liquidator

5389

*Companies Act 1961*

CLARE STREET TENTS PTY. LTD.  
(FORMERLY FREEDOM CANVAS CO.  
PTY. LTD.)

(In Liquidation)

Notice of Final Meeting of Creditors and  
Contributories

Notice is given that a final meeting of the creditors and contributories of the company will be held at Unit 1, 233 Cardigan Street, Carlton, on 6 July 1989 at 11.00 a.m.

Agenda

To receive the liquidator's account of his acts and dealings and of the conduct of the winding up of hearing any explanations thereof.

Dated 23 May 1989

ROBERT A. WATERS  
Liquidator

ORR, MARTIN & WATERS, chartered accountants, 15/233 Cardigan Street, Carlton 3053. Telephone (03) 347 9155 5394

NOTICE OF FINAL MEETING IN  
VOLUNTARY WINDING UP OF A.N.A. CO-  
OPERATIVE HOUSING SOCIETY (No. 14)  
LIMITED

(In Liquidation)

Take notice that the affairs of the abovenamed society are now fully wound up and that in pursuance of the Companies (Victoria) Code and of the *Co-operative Housing Societies Act 1958*, a general meeting of the society will be held at the 7th Floor, A.N.A. House, 114 Albert Road, South Melbourne on Wednesday, 28 June 1989 at 5.00 p.m.

- (1) laying before it an account showing how the winding up has been conducted and the property of the society disposed of and giving any explanation thereof; and
- (2) passing a resolution that the books and papers of the said society and of the liquidator relevant to the affairs of the society be destroyed after a period of twelve months from the meeting.

W. L. J. CROFTS  
Liquidator

5453

*Victoria Government Gazette*

NOTICE OF FINAL MEETING IN  
VOLUNTARY WINDING UP OF A.N.A. CO-  
OPERATIVE HOUSING SOCIETY (No. 17)  
LIMITED

(In Liquidation)

Take notice that the affairs of the abovenamed society are now fully wound up and that in pursuance of the Companies (Victoria) Code and of the *Co-operative Housing Societies Act 1958*, a general meeting of the society will be held at the 7th Floor, A.N.A. House, 114 Albert Road, South Melbourne on Wednesday, 28 June 1989 at 5.30 p.m.

- (1) laying before it an account showing how the winding up has been conducted and the property of the society disposed of and giving any explanation thereof; and
- (2) passing a resolution that the books and papers of the said society and of the liquidator relevant to the affairs of the society be destroyed after a period of twelve months from the meeting.

W. L. J. CROFTS  
Liquidator

5454

NOTICE OF FINAL MEETING IN  
VOLUNTARY WINDING UP OF A.N.A. CO-  
OPERATIVE HOUSING SOCIETY (No. 19)  
LIMITED

(In Liquidation)

Take notice that the affairs of the abovenamed society are now fully wound up and that in pursuance of the Companies (Victoria) Code and of the *Co-operative Housing Societies Act 1958*, a general meeting of the society will be held at the 7th Floor, A.N.A. House, 114 Albert Road, South Melbourne on Wednesday, 28 June 1989 at 6.00 p.m.

- (1) laying before it an account showing how the winding up has been conducted and the property of the society disposed of and giving any explanation thereof; and
- (2) passing a resolution that the books and papers of the said society and of the liquidator relevant to the affairs of the society be destroyed after a period of twelve months from the meeting.

W. L. J. CROFTS  
Liquidator

5455

Creditors, next of kin and others having claims in respect of the estate of Veronika Latinovits, late of 41 East Boundary Road, East Bentleigh, Victoria, technical assistant, deceased, who died on 11 February 1989 and probate of whose will was granted by the Supreme Court of Victoria on 11 May 1989 to the Equity Trustees Executors and Agency Company Limited of 472 Bourke Street, Melbourne, Victoria, the executor named in the said will are to send particulars of their



*Victoria Government Gazette*

claim to the said executor at its said address by 2 August 1989 after which date the said executor will distribute the assets of the said deceased having regard only to claims of which the said executor then has notice.

Dated 31 May 1989

N. D. KELLY & ASSOCIATES, of 437 Centre Road, Bentleigh, solicitors for the executor 5384

FLORENCE MERLE CLARKE, late of 181 Morris Street, Sunshine in the State of Victoria, widow, deceased

Creditors, next of kin and others having claims in respect of the estate of the deceased who died on 22 November 1988 are required by Beryl May Stonehouse of 27 Raglan Street, Avondale Heights, the executrix to whom probate of the will of the said deceased was granted by the Supreme Court of Victoria to send particulars care of the undersigned by 31 July 1989 after which date the said executrix may convey or distribute the assets having regard only to the claims of which she then has notice.

PATRICK J. CANNON, COBURN & ASSOCIATES, solicitors, 205 Hampshire Road, Sunshine 5385

LOUISA ELIZABETH SCOTT GREIG, late of Unit 5, "Sirovilla", 6 Colac Road, Belmont in the State of Victoria, spinster, deceased

Creditors, next of kin and others having claims in respect of the estate of the deceased, who died on 26 January 1989 are required by the executors David John Lindsay and Michael Geoffrey Vines both solicitors of 89 Myers Street, Geelong to send particulars to them by 1 August 1989, after which date the executors may convey or distribute the assets, having regard only to the claims of which they have had notice.

Dated 23 May 1989

WIGHTON & McDONALD, solicitors of 89 Myers Street, Geelong 5393

Creditors, next of kin and others having claims in respect of the estate of Honor Evelyn St. Omer Crane, late of Liddiard Road, Traralgon who died on 3 October 1988 are required to send particulars of the claims to the executor John Henry Crane of 8 Trees Court, Clayton South, in the care of the undersigned solicitors on or before 1 August 1989 after which date they will distribute the assets of the estate having regard only to the claims of which they then have notice.

DOBSON & GILES, solicitors of 79 Hawthorn Road, Caulfield, 3161 5402

Creditors, next of kin and others, having claims in respect of the estate of Thomas William Brook, late of Lot 53 Gilbert Street, Kilcunda who died on 14 December 1988 are required to send particulars of the claims, to the executrix Eileen

*G 21 31 May 1989 1341*

Norah Brook of Lot 53 Gilbert Street, Kilcunda, in the care of the undersigned solicitors on or before 1 August 1989 after which date they will distribute the assets of the estate having regard only to the claims of which they have notice.

DOBSON & GILES, solicitors of 79 Hawthorn Road, Caulfield, 3161 5403

Creditors, next of kin and others having claims against the estate of Alexander Skyes (also known as Alexander Hlinovsky), late of 7 Moomba Parade, Dandenong in the State of Victoria, engineer, deceased who died on 19 April 1987 are required by the Administrators Michael Hlinovsky and Nadjie Hlinovsky both of 30 Wedge Street, Dandenong to send particulars of their claims to the said Administrators care of Messrs. F. R. Monotti & Co. of 13 Scott Street, Dandenong, solicitors, by 1 September 1989 after which date they will distribute the assets of the said estate having regard only to the claims of which they then have notice.

F. R. MONOTTI & CO., solicitors, 13 Scott Street, Dandenong 5404

JOHN DICKIE, late of Tungamah, retired farmer, deceased

Creditors, next of kin and others having claims in respect of the estate of the deceased who died on 18 April 1989 are required by the trustees Leslie Charles Sampson, Stanley David Dickie and Graeme Leslie Charles Sampson of Tungamah to send particulars to them by 31 August 1989 after which date the trustees may convey or distribute the assets having regard only to the claims of which they then have notice.

HARGRAVES, barristers and solicitors, 81 Belmore Street, Yarrowonga 3730 5405

Creditors, next of kin and others, having claims in respect to the estate of Rose Curran, late of flat 15/146 Power Street, Hawthorn in the State of Victoria, widow, deceased who died on 14 December 1988 are required by the Executor National Mutual Trustees Limited of 419 Collins Street, Melbourne formerly of and in the will described as National Trustees Executors & Agency Company of Australasia Limited of 95 Queen Street, Melbourne in the said State to send particulars to it by 1 September 1989 after which date the Executor will distribute the assets having regard only to the claims of which it then has notice.

HODGSON & FINLAYSON, solicitors, 2 Stanley Street, Kew, solicitors for the estate 5401

Creditors, next of kin and others having claims in respect of the estate of Valerija Kuncaitis, late of 13 Salem Avenue, South Oakleigh, pensioner, deceased who died on 16 January 1988 are required by the Executor of her Will, Vytautas Justinas Kuncaitis of 13 Salem Avenue, South

1342 G 21 31 May 1989

Oakleigh, mailing officer to send particulars to him care of the undermentioned solicitors by 20 July 1989 after which date the Executor may convey or distribute the assets having regard only to the claims of which he then has notice.

Dated 19 May 1989

ANDERSON RICE, solicitors of 51 Queen Street, Melbourne 5429

MARY TERESA GIBBINGS, late of 15 Robbs Road, West Footscray, married woman, deceased, intestate, died on 22 December 1986. Claims to the Administrator Henry Charles Gibbings, of 15 Robbs Road, West Footscray by 31 July 1989.

JOHN F. CARROLL, LL.B., solicitor, 4 Paisley Street, Footscray 5400

SANDRA ALICE TRIPCONY, late of 1 Afton Street, Research in the State of Victoria, security officer, deceased, Intestate (who died on 14 February 1989)

Creditors, next of kin and all other persons having claims against the estate of the deceased are required by the Administrator of the estate, William Forrest Tripcony to send particulars to him care of the undersigned on or before 26 July 1989 after which date he will distribute the assets having regard only to the claims of which he then has notice.

GARDEN & GREEN, solicitors, 4 McCallum Street, Swan Hill 5432

EDWIN FREDERICK KOSSECK, late of 100 Torquay Road, Belmont in the State of Victoria formerly farmer, but late retired, deceased

Creditors, next of kin and others having claims in respect of the estate of the deceased who died on 23 March 1989 are required by the Trustee Mavis Alicia Kosseck of 100 Torquay Road, Belmont to send particulars to her by 30 July 1989 after which date the Trustee may convey or distribute the assets having regard only to the claims of which she then has notice.

Dated 22 May 1989

MESSRS. AINSWORTH & CO., solicitors of 117 Yarra Street, Geelong 5431

Creditors, next of kin and others having claims in respect of the estate of Ella Doris Sleightholm, late of 49 Kendall Street, West Preston in the State of Victoria, married woman, deceased, who died on 1 October 1988, are required by the executor Arthur James Downing to send particulars of their claims to him care of Read & Read Pty. of 422 Collins Street, Melbourne by 25 July 1989, after which date he will convey or distribute the assets having regard only to the claims of which he then has notice.

READ & READ PTY., solicitors, 422 Collins Street, Melbourne 5430

*Victoria Government Gazette*

Creditors, next of kin and others having claims in respect of the estate of James Alexander McKay, late of Chillingollah, farmer, deceased (who died on 20 November 1988) are required by the executors Kevin McMillan and Murray James McKay to send particulars to them care of the undersigned by 8 August 1989, after which date the executors may convey or distribute the assets having regard only to the claims of which they then have notice.

FINDLAY McGRATH & TOMLINSON, solicitors, 51 McCallum Street, Swan Hill 5433

JAMES WILLIAM CLEARY, late of 37 Ryan Street, Footscray, retired, deceased, died on 30 June 1985

Claims to the executor Thomas Joseph Cleary of 37 Ryan Street, Footscray by 31 July 1989.

JOHN F. CARROLL, LL.B., solicitor, 4 Paisley Street, Footscray 5428

Creditors, next of kin and others having claims in respect of the estate of Jean Eales, late of "Benbullen" Ingram Road, Coldstream in the State of Victoria, widow, deceased, who died on 3 January 1989, are to send particulars of their claims to Anne Woodward and Richard James Mackenzie, care of Messrs. Eales & Mackenzie, solicitors of 116 Main Street, Lilydale by 7 August 1989, after which date they will distribute the assets having regard only to the claims of which they then have notice.

EALES & MACKENZIE, solicitors, 116 Main Street, Lilydale 5427

JOHN GALLAGHER, late of 20/17A Milton Street, Elwood, retired, deceased

Creditors, next of kin and others having claims in respect of the deceased who died on 29 December 1988 are required by the trustee National Mutual Trustees Limited of 419 Collins Street, Melbourne (formerly and in the Will called National Trustees Executors and Agency Company of Australasia Limited of 95 Queen Street, Melbourne) to send particulars to it by 31 July 1989 after which date the trustee may convey or distribute the assets having regard only to the claims of which it then has notice.

McNAMARA & MURPHY, solicitors, 1st Floor, 306 Carlisle Street, Balaclava 5443

ESTELLA BIGGS, formerly of 2 Jetty Road, Rosebud in the State of Victoria, but late of "Eastbourne Grange" 1 Wyuna Street, Rosebud in the said State, spinster, deceased

Creditors, next of kin and others having claims in respect of the the estate of the deceased who died on 18 November 1988 are required by Graeme Richard Tibb formerly of 150 Queen Street, Melbourne but now of 685 Park Road, Park Orchards in the said State to send particulars to him by 30 July 1989 after which date the

*Victoria Government Gazette*

Executor may convey or distribute assets having regard only to the claims of which he then has notice.

Dated 31 May 1989

NICHOLAS O'DONOHUE & CO., solicitors,  
of 180 Queen Street, Melbourne 5445

LILIAN MAY CLISSOLD, late of Unit 1, Colac Road, Belmont, Geelong in the State of Victoria, widow, deceased

Creditors, next of kin and others having claims in respect of the estate of the deceased who died on 6 March 1989 are required by the Trustee Rupert Clarence Sherar (referred to in the Will as Rupert Sherar) of 7 Nelson Street, Ringwood, to send particulars to him by 31 July 1989 after which date the Trustee may convey or distribute the assets having regard only to the claims of which he then has notice.

Dated 23 May 1989

AINSWORTH & CO., solicitors, 117 Yarra Street, Geelong 5444

THELMA PHILLIPS, formerly of Flat 3, 50 Whitmuir Road, Bentleigh late of 17 Murphy Road, East Doncaster in the State of Victoria, married woman, deceased

Creditors, next of kin and others having claims in respect of the deceased (who died on 4 December 1988) are required to send particulars of their claims to the Equity Trustees Executors and Agency Company Limited of 472 Bourke Street, Melbourne before 2 September 1989 after which date the said company may convey or distribute the assets having regard only to the claims of which it then has notice.

GRAEME STEINFORT, solicitor of 562 High Street, Thornbury 5473

Creditors, next of kin and others having claims in respect of the estate of the Ethel May Lee, late of 6 Garfield Street, Cheltenham in the State of Victoria, widow, deceased, who died on 8 October 1988 are required to send particulars of their claims to the executor care of the undermentioned solicitors by a date not later than two months from the date of publication hereof after which date he will distribute the assets having regard only to the claims of which notice has been received.

LYTTLETONS, solicitors, 51 Marcus Road, Dingley 5484

DEMOSTHENOS NICOLAOU (also known as Demonstines Nicolaou), late of 182/127 Gordon Street, Footscray, pensioner

Creditors, next of kin and others having claims in respect of the estate of the deceased (who died on 6 August 1988) are required by The Executor Trustee and Agency Company of South Australia Limited of 454 Collins Street, Melbourne, to send

*G 21 31 May 1989 1343*

particulars of their claims to the said company by 31 July 1989 after which date it will convey or distribute the assets, having regard only to the claims of which the company then has notice

5485

VERA MARGARET BLACKETT MAIR (formerly called Vera Margaret Blackett Kerr), formerly of 524 Orrong Road, Toorak and 18 The Rialto, Chadstone in the State of Victoria but late of Janmar Nursing Home, 2 Chilcote Avenue, Malvern in the said State, married woman, deceased

Creditors, next of kin and others having claims in respect of the estate of the deceased who died on 8 January 1989 are required by Geoffrey James Kerr of 21 Closter Avenue, Ashwood in the State of Victoria, retired and William David Mair of "Weerona", 400 Waverley Road, East Malvern in the said State, retired, the executors appointed by the will of the said deceased to send particulars to them in the care of the undernamed solicitors by 31 July 1989 after which date they will convey or distribute the assets having regard only to the claims of which they then have notice.

Dated 22 May 1989

ARTHUR PHILLIPS & JUST, solicitors, 394 Collins Street, Melbourne 5464

GEOFFREY NEAL HANSON, late of Barrington Court Special Accommodation, 22 Fulton Street, East St Kilda, retired driver

Creditors, next of kin and others having claims in respect of the estate of the deceased (who died on 15 August 1988) are required by The Perpetual Executors and Trustees Association of Australia Limited of 50 Queen Street, Melbourne, to send particulars of their claims to the said Company by 14 August 1989 after which date it will convey or distribute the assets, having regard only to the claims of which the Company then has notice.

CORRS PAVEY WHITING & BYRNE, solicitors, 350 William Street, Melbourne 5462

JOSEPH LATONA, late of 71 Alexandra Avenue, South Yarra in the State of Victoria, television producer, deceased

Creditors, next of kin and others having claims in respect of the estate of the deceased who died on 12 March 1989 are required by the personal representatives, Johnny Ladd of 13 Gipps Street, East Melbourne and Martin John O'Dell Armstrong of 385 Bourke Street, Melbourne to send particulars to them care of the below mentioned solicitors by 31 July 1989 after which date the personal representatives may convey or distribute the assets having regard only to the claims of which they then have notice.

SLY & WEIGALL of 385 Bourke Street, Melbourne, solicitors for the estate 5466

1344 G 21 31 May 1989

EDWARD JAMES CHIPP HAMP, late of St. Anne's Nursing Home, 33 Wattle Road, Hawthorn in the State of Victoria, retired medical practitioner, deceased

Creditors, next of kin and others having claims in respect of the estate of the deceased (who died on 12 February 1989) are required by the Perpetual Executors and Trustees Association of Australia Limited of 50 Queen Street, Melbourne to send particulars of their claims to the said company by 31 July 1989 after which date it will convey or distribute the assets, having regard only to the claims of which the company then has notice.

SLY & WEIGALL, 385 Bourke Street, Melbourne 5465

HAROLD ISAAC MICHAEL, formerly of Flat 2, Pine View Flats, 3 Stonehaven Court, Toorak, in the State of Victoria but late of the Montefiore Homes for the Aged, 95 High Street Road, Ashwood in the said State, retired pharmaceutical chemist, deceased

Creditors, next of kin and others having claims in respect of the estate of the deceased (who died on 26 July 1988) are required by The Equity Trustees Executors and Agency Company Limited of 472 Bourke Street, Melbourne in the said State and Rosemary Eva Michael (in the Will called Rosemary Eva Pass) of 4 Avoca Court, Ashwood in the said State, home duties, to send particulars of their claims to the said Company by 7 August 1989 after which date it will convey or distribute the assets having regard only to the claims of which the Company then has notice.

CORRS PAVEY WHITING & BYRNE, solicitors, 350 William Street, Melbourne 5461

NANCE BERYL CUTLAND, formerly of 163 Charman Road, Mentone but late of Kiama Private Hospital, 15 Staniland Street, East Malvern in the State of Victoria, widow, deceased

Creditors, next of kin and others having claims in respect of the estate of the deceased, who died on 30 December 1988 are required by the Trustee, National Mutual Trustees Limited of 419 Collins Street, Melbourne in the State of Victoria to send particulars to it by 2 August 1989, after which date the Trustee may convey or distribute the assets having regard only to claims of which it then has notice.

Dated 22 May 1989

CARROLL & DILLON, solicitors, 84 William Street, Melbourne 5463

MARJORIE CHRISTINA RAY, formerly of 681 Sydney Road, Brunswick but late of 1/33 Woodlands Avenue, East Kew, retired hotel keeper, deceased

*Victoria Government Gazette*

Creditors, next of kin and others having claims in respect of the estate of the deceased who died on 1 May 1989 are required by the legal personal representatives Jaanette Dorothy Overall Enden and John Maurice Davies both of 257 Collins Street, Melbourne, solicitors to send particulars to them by 31 August 1989 after which date they will distribute the assets having regard only to the claims of which they then have notice.

E. P. JOHNSON & DAVIES of 257 Collins Street, Melbourne 5470

LAWRENCE FITZGERALD, late of 33 Queen Street, Ormond in the State of Victoria, retired army officer, deceased

Creditors, next of kin and others hearing claims in respect of the estate of the deceased who died on 26 December 1988 are required by the trustee National Mutual Trustees Limited of 419 Collins Street, Melbourne to send particulars to it by 31 July 1989 after which date the trustee may convey or distribute the assets having regard only to the claims of which they then have notice.

PHILLIPS FOX, solicitors of 461 Bourke Street, Melbourne 5471

CLARA BEATRICE MALCOLM, late of Hanslope Private Nursing Home, 12 Hanslope Avenue, Alphington in the State of Victoria, spinster, deceased

Creditors, next of kin and others having claims in respect of the estate of the deceased, who died on 15 September 1988 are required by the trustee, Peter Frederick Coldbeck of 140 William Street, Melbourne in the said State to send particulars to him by 1 August 1989 after which date the trustee may convey or distribute the assets, having regard only to the claims of which the trustee then has notice.

HALL & WILCOX, solicitors, 140 William Street, Melbourne 5472

On 13 July 1989 at 2.30 p.m. at the Sheriff's Office, 287 Springvale Road, Glen Waverley (unless process be stayed or satisfied).

All the estate and interest (if any) of Ismail Yucedag of 141 Glenroy Road, Glenroy as joint proprietor with Neyime Yucedag and Erol Yucedag of an estate in fee simple in the land described in Certificate of Title Volume 7654 Folio 157 upon which is erected a dwelling known as 141 Glenroy Road, Glenroy.

Registered Mortgage No. M468480H and Caveat No. P85922K affect the said estate and interest.

Terms—Cash only  
5467 H. BUETTNER, Sheriff's Officer

*Victoria Government Gazette*

*G 21 31 May 1989 1345*

On 13 July 1989 at 2.30 p.m. at the Sheriff's Office, 287 Springvale Road, Glen Waverley (unless process be stayed or satisfied).

All the estate and interest (if any) of Kenneth John House of 53 Stanton Crescent, Rosanna shown on Certificate of Title as Ken John House as proprietor of an estate in fee simple in the land described in Certificate of Title Volume 4211 Folio 156 upon which is erected a dwelling known as 21 Malvern Grove, Caulfield.

Registered Mortgage Nos. L889720V and N67513E affect the said estate and interest.

Terms—Cash only

5468 H. BUETTNER, Sheriff's Officer

On 13 July 1989 at 2.30 p.m. at the Sheriff's Office, 287 Springvale Road, Glen Waverley (unless process be stayed or satisfied).

All the estate and interest (if any) of Frank Iannazzo of 12 Stawell Street, Geelong as proprietor of an estate in fee simple in the land described on Certificate of Title Volume 8031 Folio 994 upon which is erected a dwelling known as 15 Disney Street, Fawkner.

Registered Mortgage No. M567482Y and Caveats M562338P and M865130F and N864239S and M985639A affect the said estate and interest.

Terms—Cash only

5469 H. BUETTNER, Sheriff's Officer

1346 G 21 31 May 1989

Victoria Government Gazette

**NOTICE OF MAKING OF  
STATUTORY RULES  
WHICH ARE NOT YET  
AVAILABLE**

Notice is given of the making of the following Statutory Rules:

- Liquor Control Act 1987*
- 111/1989 Liquor Control (Licences and Permit Fees) (Amendment) Regulations 1989
- Food Act 1984*
- 112/1989 Food Standards (Amendment) Regulations 1989
- Transport Accident Act 1986*
- 113/1989 Transport Accident (Charges) (Amendment) Regulations 1989
- Annual Reporting Act 1983*
- 114/1989 Annual Reporting (Contributed Income Sector) (Amendment) Regulations 1989

**NOTICE OF MAKING  
AND AVAILABILITY OF  
STATUTORY RULES**

In pursuance of the provisions of the *Subordinate Legislation Act 1962* and the Regulations made thereunder notice is given of the making and availability of the following Statutory Rules:

Note: The date specified after each Statutory Rule is the date it was first obtainable from—  
VGPO Bookshop  
Information Victoria Centre  
318 Lt Bourke Street, Melbourne

- Police Regulation Act 1958*
- 109/1989 Police (Constitution, Strength, Organisation and Seniority) (Amendment) Regulations 1989
- 25 May 1989 Code 1
- Public Account Act 1958*
- 110/1989 Victorian Development Fund (Treasury Bills) Regulations 1989
- 25 May 1989 Code 1

Price Code	No. of Pages (Including cover and blank pages)	Price
1	1-4	\$0.42
2	5-8	\$0.75
3	9-12	\$1.05
4	13-16	\$1.50
5	17-24	\$1.80
6	25-32	\$2.25
7	33-40	\$2.55
8	41-48	\$2.85
9	49-56	\$3.20
10	57-64	\$3.50
11	65-72	\$3.80
12	73-80	\$4.00
13	81-88	\$4.45
14	89-96	\$4.80
Each additional 16 pages or part thereof		\$0.63

*Victoria Government Gazette*

*G 21 31 May 1989 1347*

1348 G 21 31 May 1989

*Victoria Government Gazette*



*Victoria Government Gazette*

*G 21 31 May 1989 1349*

1350 G 21 31 May 1989

*Victoria Government Gazette*

*Victoria Government Gazette*

*G 21 31 May 1989 1351*

1352 G 21 31 May 1989

*Victoria Government Gazette*

*Victoria Government Gazette*

*G 21 31 May 1989 1353*

1354 G 21 31 May 1989

*Victoria Government Gazette*

*Victoria Government Gazette*

*G 21 31 May 1989 1355*

**CONTENTS**

	Page
Appointments	1310
Contracts	1303
Contracts Accepted—Amendments	1303
Estates of Deceased Persons	1307
Government Notices	1287
Notice of Making of Statutory Rules	1346
Orders in Council—	
Acts—Cemeteries; Crown Land (Reserves); Corrections; Housing; Historic Buildings; Kew and Heidelberg Lands; Lands; Road Safety; Water and Sewerage Authorities (Restructuring); Water	1311
Police Sale	1303
Private Advertisements	1320
Proclamations	1286
Tenders	1319

A Victorian Government Publication

Published by VGPO  
Melbourne Victoria Australia  
© State of Victoria 1989

This publication is copyright. No part may be reproduced  
by any process except in accordance with the provisions  
of the Copyright Act.

Address all inquiries to the Government Printer  
for the State of Victoria  
PO Box 203 North Melbourne 3051 Victoria Australia  
ISSN 0819—5471

Jean Gordon Government Printer Melbourne

**Counter Sales**

Information Victoria Bookshop  
318 Lt. Bourke Street Melbourne 3000  
Telephone inquiries (03) 663 3760

**Mail and Bulk Order Sales**

VGPO  
PO Box 203 North Melbourne 3051  
7-21 Boundary Road North Melbourne 3051  
Telephone inquiries (03) 326 6240

**Recommended Retail Price \$1.15**