

# VICTORIA GOVERNMENT GAZETTE

No. G25 Wednesday 1 July 1992

By Authority L. V. North, Government Printer Melbourne

GENERAL

## Gazette Services

The *Victoria Government Gazette* (VGG) is published by THE LAW PRINTER (PPSV) for the State of Victoria and is produced in three editions.

**VGG General** is published each Wednesday and provides information regarding Acts of Parliament and their effective date of operation; Government notices; requests for tenders; as well as contracts and contracts accepted. Private notices are also published.

**VGG Special** is published any day when required for urgent or special Government notices. VGG special is made available automatically to subscribers of VGG General.

**VGG Periodical** is published on Monday when required and includes specialised information eg. Medical, Dental, Pharmacist's Registers, etc.

## Government Advertising

### Publishing Details

The following Guidelines should be forwarded to ensure publication of Government material in the *Victoria Government Gazette*.

- Duplicate copies should be submitted for use by the Gazette Officer.
- Material submitted to the Executive Council for gazettal will normally be published in the following week's issue.
- Where urgent gazettal is required, contact:  
Gerd Gaspar  
Gazette Officer  
Department of the Premier and Cabinet  
Ground Floor 1 Treasury Place  
Melbourne 3000  
Telephone inquiries (03) 651 5153
- Government advertising other than material for the consideration of the Executive Council should be forwarded to the Gazette Office no later than 9.30 a.m. on Tuesday.
- Lengthy or complicated notices should be forwarded several days before publication.
- Proofs will be supplied only when requested or at the direction of the Gazette Officer.
- No additions or amendments to material for publication will be accepted by telephone.

### Advertising Rates and Payment

#### General Gazette

Single column x cm/part cm \$2.65  
Double column x cm/part cm \$5.30  
Full page \$111.00

#### Periodical Gazette

Full page \$115.50

#### Special Gazette

Full page \$233.00.

## Private Advertisements

### Publishing Details: Send copy to:

VGG Coordinator  
Gazette Advertising  
THE LAW PRINTER  
28 Queensbridge Street, South Melbourne  
(PO Box 292 South Melbourne 3205)  
Telephone inquiries (03) 2424600  
Fax No. (03) 2424699

### Advertising Rates and Payment

#### General Gazette

Single column x cm/part cm \$4.10  
Double column x cm/part cm \$8.20  
Full page \$171.50

#### Periodical Gazette

Full page \$180.00

#### Special Gazette

Full page \$360.00

Cheques should be made payable to 'THE LAW PRINTER'.

These rates apply to advertisements printed on or after 14 February 1990.

### Advertisers should note:

- There are approximately 20 words to each column centimetre depth.
- Signatures (in particular) and proper names must also be in block letters.
- All material should be double spaced.
- Advertisements can be faxed, and a cover sheet should be used, marked to the attention of the Gazette Coordinator.
- Documents not clearly prepared and in the exact format for gazettal will be returned to the sender unpublished.
- Late copy received at THE LAW PRINTER after 11.00 a.m. Monday will be placed in the following issue of VGG, irrespective of any date/s mentioned in the copy (unless otherwise advised).

### Copy Deadline

11.00 a.m. Monday

## Subscriptions

VGG is available by three subscription services:

General and Special—\$160.00 each year  
General, Special and Periodical—\$212.00 each year  
Periodical—\$106.00 each year

Subscriptions are payable in advance and accepted for a period of one year. All subscriptions are on a firm basis and refunds for cancellations will not be given.

All payments should be made payable to THE LAW PRINTER.  
Subscription inquiries (03) 2424600  
Fax (03) 2424699

**PROCLAMATIONS**

ACTS OF PARLIAMENT  
PROCLAMATION

I, Richard E. McGarvie, Governor of Victoria declare that I have today assented in Her Majesty's name to the following Bills:

No. 40/1992 National Parks (Wilderness) Act;

No. 41/1992 Road Safety (Licence Cancellation) Act;

No. 42/1992 Bank Integration Act;

No. 43/1992 Partnership (Limited Partnerships) Act;

No. 44/1992 Swinburne University of Technology Act;

No. 45/1992 Royal Melbourne Institute of Technology Act;

No. 46/1992 Agricultural and Veterinary Chemicals Act;

No. 47/1992 Industrial Relations (Enterprise Bargaining) Act.

Given under my hand and the seal of Victoria at Melbourne on 23 June 1992.

(L.S.) R. E. MCGARVIE  
By His Excellency's Command

JOAN KIRNER  
Premier

No. 40/1992 (1) Parts 1, 3, 7 and 9 come into operation on the day on which this Act receives the Royal Assent.

(2) Part 2 comes into operation on a day to be proclaimed.

(3) Part 4 comes into operation on a day to be proclaimed.

(4) Part 5 comes into operation on a day to be proclaimed.

(5) Part 6 comes into operation on a day to be proclaimed.

(6) Part 8 comes into operation on a day to be proclaimed.

No. 41/1992 This Act comes into operation on the day on which it receives the Royal Assent.

No. 42/1992 This Act comes into operation on a day to be proclaimed.

No. 43/1992 This Act comes into operation on a day or days to be proclaimed.

No. 44/1992 This Act comes into operation on a day or days to be proclaimed.

No. 45/1992 This Act comes into operation on a day or days to be proclaimed.

No. 46/1992 This Act comes into operation on a day or days to be proclaimed.

No. 47/1992 This Act comes into operation on a day to be proclaimed.

20660

*Royal Melbourne Institute of Technology Act*  
1992

PROCLAMATION OF COMMENCEMENT

I, Richard E. McGarvie, Governor of Victoria, acting with the advice of the Executive Council under section 2 of the *Royal Melbourne Institute of Technology Act 1992* fix 1 July 1992 as the day on which the Act comes into operation.

Given under my hand and the seal of Victoria on 30 June 1992

(L.S.) R. E. MCGARVIE  
By His Excellency's Command

TOM ROPER  
Minister for Employment, Post-Secondary  
Education and Training

20980

*Collingwood Land (Victoria Park) Act 1992*  
PROCLAMATION

I, Richard E. McGarvie, Governor of Victoria, acting with the advice of the Executive Council and pursuant to the power in section 2 of the *Collingwood Land (Victoria Park) Act 1992* fix Wednesday, 1 July 1992 as the day on which the *Collingwood Land (Victoria Park) Act 1992*, except sections 1 to 4, shall come into operation.

Given under my hand and the seal of Victoria on 30 June 1992

(L.S.) R. E. MCGARVIE  
By His Excellency's Command

JIM KENNAN  
Deputy Premier and  
Attorney-General

20430

**Mental Health Act 1986  
PROCLAMATION**

I, Richard E. McGarvie, Governor of Victoria, acting with the advice of the Executive Council and under section 94 (2) of the *Mental Health Act 1986*, proclaim part of Travancore Child and Family Centre, being the room to the immediate left of the entrance to the unit known as Banksia Unit and hatched on the accompanying map, to be an approved psychiatric unit of the Royal Children's Hospital from 1 July 1992.

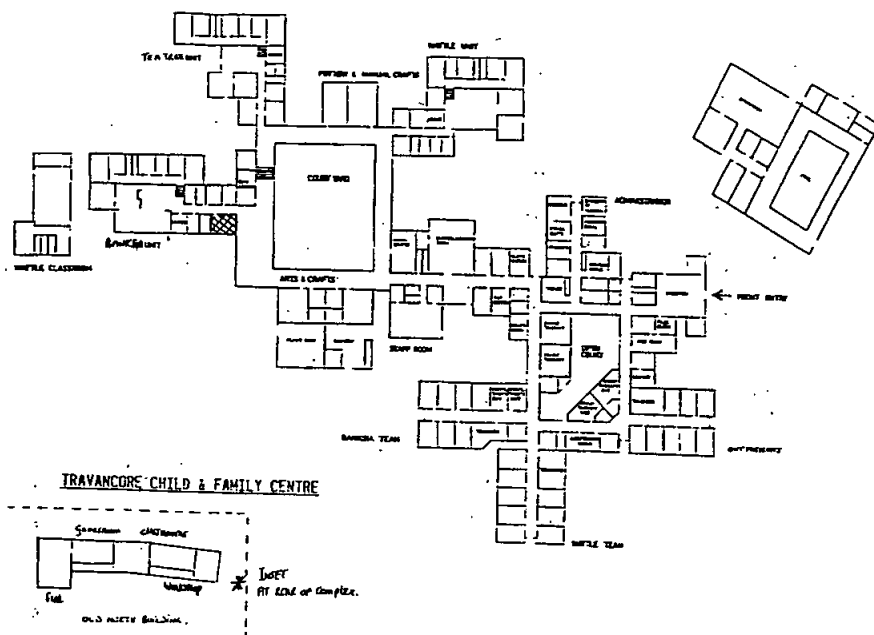

Given under my hand and the seal of Victoria on 30 June 1992

(L.S.) R. E. MCGARVIE  
By His Excellency's Command  
MAL SANDON  
Acting Minister for Health

20370

**Mental Health Act 1986  
REVOCATION**

I, Richard E. McGarvie, Governor of Victoria, acting with the advice of the Executive Council and under section 94 (4) (a) of the *Mental Health Act 1986*, revoke the proclamation under section 94 (1) of the *Mental Health Act 1986* of premises known as Travancore Child and Family Centre as an approved psychiatric hospital from 1 July 1992.

Given under my hand and the seal of Victoria on 30 June 1992

(L.S.) R. E. MCGARVIE  
By His Excellency's Command

MAL SANDON  
Acting Minister for Health

20370

1628 G 25 1 July 1992

*Land Act 1958*  
PROCLAMATION OF ROAD

I, Richard E. McGarvie, Governor of Victoria, acting with the advice of the Executive Council and under section 25 (3) (c) of the *Land Act 1958* proclaim as road the following land:

MUNICIPAL DISTRICT OF THE SHIRE OF  
DUNMUNKLE

RUPANYUP—The land in the Parish of Rupanyup as indicated by hatching on plan hereunder—(R 76 (8)) (L4-5195).

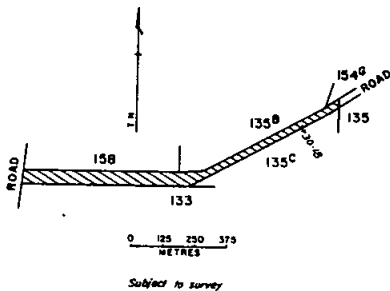

Given under my hand and the seal of  
Victoria on 30 June 1992.

(L.S.) R. E. MCGARVIE  
By His Excellency's Command

BARRY PULLEN  
Minister for Conservation  
and Environment

20090

*Land Act 1958*  
PROCLAMATION OF ROADS

I, Richard E. McGarvie, Governor of Victoria acting with the advice of the Executive Council and under section 25 (3) (c) of the *Land Act 1958* proclaim as roads the following lands:

MUNICIPAL DISTRICT OF THE BOROUGH  
OF EAGLEHAWK

EAGLEHAWK—Crown Allotment 517G, Section M, at Eaglehawk, Parish of Sandhurst as shown on Certified Plan No. 110888 lodged in the Central Plan Office—(P 126108).

MUNICIPAL DISTRICT OF THE SHIRE OF  
SOUTH GIPPSLAND

FOSTER—Crown Allotment 21A, Section 2 and Crown Allotment 5A, Section 15, Township of Foster, Parish of Wonga Wonga South as

*Victoria Government Gazette*  
shown on Certified Plan No. 109728 lodged in the Central Plan Office—(14/87/1101).

Given under my hand and the seal of  
Victoria on 30 June 1992

(L.S.) R. E. MCGARVIE  
By His Excellency's Command

BARRY PULLEN  
Minister for Conservation  
and Environment

20090

*Swinburne University of Technology Act 1992*  
PROCLAMATION OF COMMENCEMENT

I, Richard E. McGarvie, Governor of Victoria acting with the advice of the Executive Council and under section 2 of the *Swinburne University of Technology Act 1992* fix 1 July 1992 as the day on which the Act comes into operation.

Given under my hand and the seal of  
Victoria on 30 June 1992

(L.S.) R. E. MCGARVIE  
By His Excellency's Command

TOM ROPER  
Minister for Employment,  
20980 Post-Secondary Education and Training

*Melbourne University (VCAH) Act 1992*  
PROCLAMATION OF COMMENCEMENT

I, Richard E. McGarvie, Governor of Victoria, acting with the advice of the Executive Council under section 2 of the *Melbourne University (VCAH) Act 1992* fix 1 July 1992 as the day on which Part Two excepting section 13, Part Three and the Schedule of the Act come into operation.

Given under my hand and the seal of  
Victoria on 30 June 1992

(L.S.) R. E. MCGARVIE  
By His Excellency's Command

TOM ROPER  
Minister for Employment, Post-Secondary  
20160 Education and Training

*Victoria Government Gazette*

*Melbourne Water Corporation Act 1992*  
PROCLAMATION OF COMMENCEMENT

I, Richard E. McGarvie, Governor of Victoria, acting with the advice of the Executive Council and under section 2 of the *Melbourne Water Corporation Act 1992*, fix Wednesday, 1 July 1992 as the day on which the whole of that Act (except section 2) comes into operation.

Given under my hand and the seal of Victoria on 30 June 1992

(L.S.) R. E. McGARVIE  
By His Excellency's Command

S. M. CRABB  
21210 Minister for Water Resources

G 25 1 July 1992 1629

*Water (Rural Water Corporation) Act 1992*  
PROCLAMATION OF COMMENCEMENT

I, Richard E. McGarvie, Governor of Victoria, acting with the advice of the Executive Council and under section 2 of the *Water (Rural Water Corporation) Act 1992*, fix Wednesday, 1 July 1992 as the day on which that Act comes into operation.

Given under my hand and the seal of Victoria on 30 June 1992

(L.S.) R. E. McGARVIE  
By His Excellency's Command

S. M. CRABB  
21210 Minister for Water Resources

*Wildlife (Amendment) Act 1990*  
PROCLAMATION OF COMMENCEMENT

I, Richard E. McGarvie, Governor of Victoria, acting with the advice of the Executive Council, and under section 2 of the *Wildlife (Amendment) Act 1990*, fix Wednesday, 1 July 1992 as the day on which the remaining sections except sections 6 (3), 6 (4) and 6 (5) of that Act come into operation.

Given under my hand and the seal of Victoria on 30 June 1992.

(L.S.) R. E. McGARVIE  
By His Excellency's Command

BARRY PULLEN  
20090 Minister for Conservation  
and Environment

*Financial Institutions (Victoria) Act 1992*  
PROCLAMATION

I, Richard E. McGarvie, Governor of Victoria, acting with the advice of the Executive Council fix Wednesday, 1 July 1992 as the day on which Parts 2 to 4, 6 to 10, the remaining provisions of Part 11 except sections 76 (2) (c), (d) and (e), the remaining provisions of Part 12 except section 84 (1) (zn) and Parts 13 to 15 of the *Financial Institutions (Victoria) Act 1992* come into operation.

Given under my hand and the seal of Victoria on 30 June 1992

(L.S.) R. E. McGARVIE  
By His Excellency's Command

JIM KENNAN  
20430 Deputy Premier and  
Attorney-General

*Royal Botanic Gardens Act 1991*  
PROCLAMATION OF COMMENCEMENT

I, Richard E. McGarvie, Governor of Victoria, acting with the advice of the Executive Council, and under section 2 of the *Royal Botanic Gardens Act 1991*, fix Wednesday, 1 July 1992 as the day on which that Act comes into operation.

Given under my hand and the seal of Victoria on 30 June 1992.

(L.S.) R. E. McGARVIE  
By His Excellency's Command

BARRY PULLEN  
20090 Minister for Conservation  
and Environment

### GOVERNMENT NOTICES

*Private Agents Act 1966*

NOTICE OF RECEIPT OF APPLICATIONS FOR LICENCES

Any objections to the applications below should be in accordance with the *Private Agents Act 1966* s. 12 and *Private Agents Regulations 1988*, reg. 16

<i>Full name of Applicant/Nominee</i>	<i>Residential Address</i>	<i>Name of Firm or Corporation</i>	<i>Address for Registration</i>	<i>Licence Type</i>	<i>Hearing Date and Court</i>
Irving, Kathryn	46 Pearce St, Wodonga	Border Mercantile Agency	46 Pearce St, Wodonga	CA	7.7.92

20620

\*Licence Type: CA—Commercial Agent; CS—Commercial Sub-Agent; P—Process Server; IA—Inquiry Agent; G—Guard Agent; W—Watchman

*Survey Co-ordination Act 1958*  
PLACE NAMES COMMITTEE

1. NOTICE OF PROPOSAL TO ASSIGN PLACE NAMES

The Place Names Committee gives notice that it proposes to assign the undermentioned place names. Any objections to a proposed name must be in writing (stating the reasons therefore) and be lodged with the Secretary to the Committee within two months of the publication of this notice.

<i>Place Name</i>	<i>Location</i>
Outer Circle Railway Linear Park	Proposal from the Department of Conservation and Environment to name the former Outer Circle Railway Reserve from Princess Street, Kew to the railway line near Hughesdale Station.
Newberry Creek	Proposal from the Shire of Benalla to name a previously un-named watercourse in the Parish of Lima.
Montrose Brickworks Flora Reserve	Proposal from the Shire of Lillydale to name a reserve at the corner of Cambridge and Montrose Roads, Montrose.
Davies Hill	Proposal from the Shire of Buninyong to name a hill to the north of the township of Napoleons.
R. W. Stone Reserve	Proposal from the Shire of Hastings to name a reserve in Camp Hill Road, Somers.
Saint Helena Bush Reserve	Proposal from the Shire of Diamond Valley to name a reserve in Liddesdale Grove, Saint Helena.
Evelyn Reserve	Proposal from the City of Oakleigh to name a reserve in Evelyn Street, Clayton.
Balliang East, Cocoroc, Exford, Eynesbury, Laverton, Laverton North, Laverton South, Little River, Mambourin, Mount Cotrell, Point Cook, Parwan, Quandong, Tarnait, Truganina, Werribee, Werribee South and Western Gardens	Proposal from the City of Werribee to assign the names and define the boundaries of 20 localities within the municipality (see map below). Individual locality plans may be inspected at the Municipal Offices, or the Office of the Place Names Committee.
Hoppers Crossing, Wyndham Vale	Proposal from the City of Werribee to re-define the boundaries of these two areas previously defined in the <i>Victoria Government Gazette</i> of 4 April 1975, page 739 and 29 November 1978, page 3679 respectively.

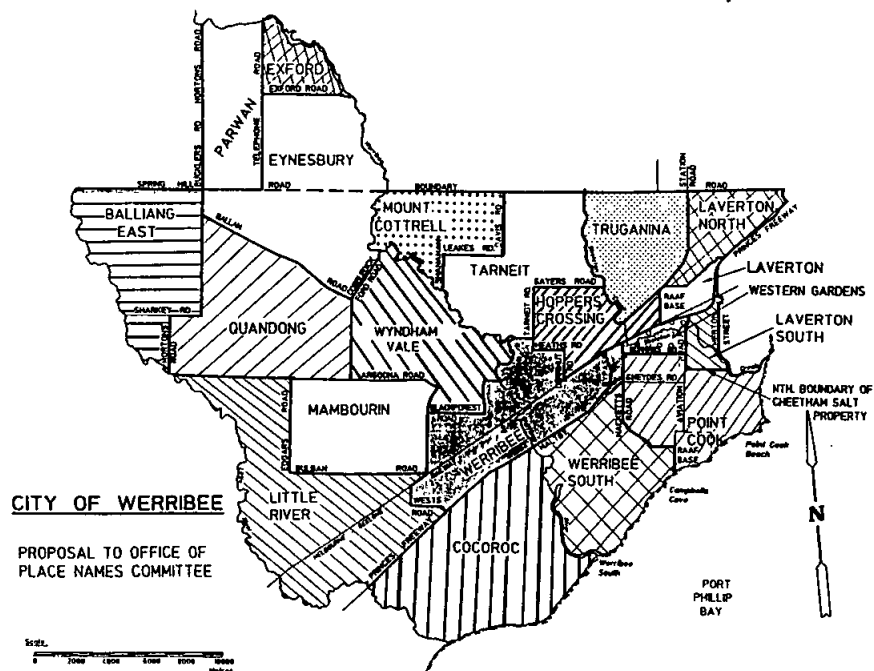

2. NOTICE OF PROPOSAL TO ALTER PLACE NAMES

The Place Names Committee gives notice that it proposes to alter the undermentioned place names in the manner indicated. Any objections to a proposal must be in writing (stating the reasons therefor) and be lodged with the Secretary to the Committee within two months of the publication of this notice.

<i>Present Name</i>	<i>Proposed Name</i>
Murray-Sunset National Park	Yanga-nyawi (Murray-Sunset) National Park
Footscray Primary School	Footscray City Primary School
Myrtleford Consolidated School	Myrtleford Primary School
Elwood (that portion within the City of Brighton only).	Brighton (plan of area available for inspection at the Municipal Offices or the Office of the Place Names Committee).

Place Names Committee  
 care of Survey and Mapping Victoria  
 2 Treasury Place, Melbourne 3000

20670

RON McLEOD  
 Secretary

## TRAVEL AGENTS LICENSING AUTHORITY

The Travel Agents Licensing Authority hereby publishes amendments to the list of licensed travel agents published in the *Victoria Government Gazette* No. G21 dated 3 June 1992 and to subsequent monthly amendments.

Suppliers of travel services should not deal with a person or corporation not included on the list, unless that person or corporation is able to produce a travel agent's licence or can satisfy the supplier that he or she or it is exempt from being required to hold a licence.

In accordance with section 37 (2A) of the *Travel Agents Act* 1986, amendments to this list will be published in the first V.G.G. of each month.

C. TIKOTIN, Registrar  
Travel Agents Licensing Authority

## AMENDMENTS TO LIST OF LICENSED TRAVEL AGENTS

Date of preparation: 26 June 1992

1. The following Travel Agents and/or business names are to be ADDED to the list of Licensed Travel Agents:

<i>Name under which business conducted</i>	<i>Licensee</i>	<i>Licence Number</i>
Alfy Travel Agency	Mikhael, Rafik	31658
ECT (Educational Central Tours)	Scorgie, George William	31562
ECT (Educational Central Tours)	Sewell, Alan Ernest	31648
Gordons International Pty. Ltd.	Gordons International Pty. Ltd.	30639
Harvey World Travel (Mill Park)	Sarraville Pty. Ltd.	30336
Horizons Travel Pty. Ltd.	Horizons Travel Pty. Ltd.	31640
Jetset Travel Dandenong	Destination Travel Management P/L	31185
Jetset Travel Fitzroy North	Lesit Shipping International P/L	30051
May-Way Travel	McCracken, May Yoke	31642
New World Travel	SFM Pty. Ltd.	31620
Paradise Island Holidays	Professional Travel Services Pty. Ltd.	31597
Travel On Pty. Ltd.	Travel On Pty. Ltd.	31627
Waverley Travel	Holiday Club International (A'asia) Pty. Ltd.	31473

2. The following Travel Agents and/or business names are to be DELETED from the list of Licensed Travel Agents:

<i>Name under which business conducted</i>	<i>Licensee</i>	<i>Licence Number</i>
Allways Dive Expeditions	Skinner, Geoffrey James	30525
Allways Tours	Skinner, Geoffrey James	30525
Allways Travel Service	Skinner, Geoffrey James	30525
Balcombe Travel & Tours Pty. Ltd.	Balcombe Travel & Tours Pty. Ltd.	30747
Britannia Travel Service	Haines, Brettwell Charles	30595
CMCL Business Services	McLennan, Christine Maree	31231
Fasciale Travel Services	Joe Fasciale & Associates Pty. Ltd.	30614
Five Star Travel	Five Star Travel (International) P/L	31033
Five Star Travel (International) P/L	Five Star Travel (International) P/L	31033



<i>Name under which business conducted</i>	<i>Licensee</i>	<i>Licence Number</i>
Giramondo Travel Agency	Giramondo, Luigi	30792
Giramondo Travel Agency	Giramondo, Maria	30910
Gordons International	Morning Star Travel Service (Australia) Pty. Ltd.	30639
Mettravel Tours	Metro Friendly Society	30309
Samlor Adventure Tours	Alma Travel Service Pty. Ltd.	30612
Travelcade of Bayswater	Alburnum Pty. Ltd.	30196
Waverley Travel	Holiday Club International (A'asia) Pty. Ltd.	31476
Waverley Travel Centre	Holiday Club International Pty. Ltd.	30768

52086

**MELBOURNE WATER****General Notice****Declaration of Sewerage Areas**

Melbourne Water having made provision for carrying off the sewage of each and every property which or any part of which is situated in the Sewerage Areas hereinafter described doth hereby declare that on and after 1 July 1992 each and every property so situated shall be deemed to be a seweraged property within the meaning of *Melbourne and Metropolitan Board of Works Act 1958*.

The Sewerage Areas hereinbefore referred to are:

**Sewerage Area No. 7839**

City of Berwick—This area comprises Lots 16 to 26 Sirius Place, Lots 14, 15, 27 to 31 Halcyon Way and contains 18 lots.

**Sewerage Area No. 7843**

City of Berwick—This area comprises Lots 429 to 436, 943 to 948, 428 to 413, a reserve, Lots 412 to 396, 245 to 247, a reserve, Lots 248 to 263, 298 to 300, 310, 311, a drainage reserve, Lot 312 Telford Drive, All Lots in Confait Court, All Lots in Glenbrae Court, Lots 349 to 344, a reserve, Lots 343 to 338 Kuranda Crescent, Lots 269 to 275 Shand Court, Lots 313 to 317 Avebury Drive and contains 117 lots.

**Sewerage Area No. 7844**

City of Berwick—This area comprises Lots 186, 187, 199, 209 Godwin Avenue, Lots 210 to 212, 215 Buckingham Close, Lots 198 to 188 Warwickshire Court, Lots 185 to 182, 181, 180, 162, 171 to 173, 178, 179 Denver Drive, All Lots in Dalbury Place, All Lots in Hampton Close, and contains 43 lots.

**Sewerage Area No. 7846**

City of Berwick—This area comprises Lots 93 to 99 Boomerang Court, Lots 53, 23 to 28, 48 to 52, 90 James Bathe Way, All Lots in Karrum Karrum Court, a tree reserve, All Lots in Sarah Court, All Lots in Bunerong Court, Lots 54, 55, 21, 22 Toomah Street, Lots 11, 143 to 147 Garem Gam Wynd, Lots 148, 149 Nana Walk, Lots 10 to 4, a reserve, Lots 3 to 1, 12 to 20 Strathard Drive, Lots 75 to 78, 86 to 99, 111 to 127, 110 to 100 Baringa Park Drive, All Lots in Capsian Place, Lots 189 to 199 Dewsbury Court, Lots 130 to 138 Abercairn Drive, All Lots in Addlington Court, Lots 23 to 27, 42 to 44 Oakgrove Drive, All Lots in Oxenford Rise, Lots 45 to 49 Eastbury Court, and contains 226 lots.

**Sewerage Area No. 7849**

City of Berwick—This area comprises Lots 449 to 451 Quadrat Close, Lots 452 to 466 Festival Terrace, All Lots in Sunnyside Drive, All Lots in Magdalena Place, Lots 625 to 620, 585, 584, 592 to 586, 619 to 614, 555, 554, 532 a reserve, Leonard Avenue, All Lots in Adelaide Close, Lots 610, 611, a drainage easement, a reserve, 612, 613, 581 to 583, 593, a reserve, The Gateway, All Lots in Emma Court, All Lots in Theodore Terrace, All Lots in Coowarra Road, a reserve, All Lots in Oscar Court, Lots 467 to 472, 355, 351A, 351B, 350, 349, 348B, 348A, a reserve, 347B, 347A, 346A, 346B, 345, 344, 381B, 381A, 365, 364B, 364A, 356, 357A, 357B Coolong Avenue, All Lots in Messmate Court, All Lots in Gumnut Court, All Lots in Nerang Court, All Lots in Boree Court, All Lots in Wimmera Court, Lots 394 to 390, 330 to 328A, 328B, 327 to 322A, 322B, 321 to 319, 446 to 443, 433 to 436, 415 to 413, 398 Coowarra

1634 G 25 1 July 1992

Way, All Lots in Camden Court, All Lots in Jericho Court, All Lots in Mitre Crescent, and contains 402 lots.

Sewerage Area No. 7851

City of Berwick—This area comprises Lots 77 to 90 Joyce Avenue, and contains 14 lots.

Sewerage Area No. 7852

City of Berwick—This area comprises Lots 35 to 54, 63 to 65, 74 to 76, 34 to 32, 15 to 13 London Crescent, Lots 31, 28 to 25 Lucy Court, All Lots in Sidney Court, All Lots in James Court, and contains 53 lots.

Sewerage Area No. 7853

City of Berwick—This area comprises Lots 128 to 132, 139 to 142, a reserve, Lots 143 to 157, 90, 91, 97 to 100, 107 to 110, 117 to 121, 126, 127 Kendall Drive, All Lots in Cliff Court, All Lots in Peter Court, All Lots in Claire Court, All Lots in Joshua Court, All Lots in Acre Court, Lots 250, 249, 242 to 239, 232 to 229, 222 to 219, 212 to 209, 191 to 186, Maramba Primary School, Maramba Drive, Lots 248 to 245 Brenda Court, All Lots in Lana Court, All Lots in Naomi Court, All Lots in Miriam Court, Lots 208, 202 to 192 Anaconda Road, Lots 185, 184 Tarcoola Drive, Lots 182 to 172 Eskdale Court, Lots 152 to 157, a reserve, Lots 158, 158 Josephine Avenue, and contains 147 lots.

Sewerage Area No. 7854

City of Berwick—This area comprises Lots 164 to 155, 152 to 130 Garnet Close, a plantation reserve, Lots 68 to 73 Ellenvale Drive, Lot 86 Kilfera Court, and contains 40 lots.

Sewerage Area No. 7856

City of Berwick—This area comprises Lots 1, 2, 15, 16, 46 to 38 Centre Road, All Lots in Kelburn Road, All Lots in Willunga Court, and contains 76 lots.

Sewerage Area No. 7857

City of Berwick—This area comprises All Lots in Dianna Court, All Lots in Emma Court, Lots 722 to 718, a reserve, Lot 751 Lesley Drive, and contains 34 lots.

Sewerage Area No. 7840

Shire of Cranbourne—This area comprises Lot 12 Hallam Road, and contains 1 lot.

Victoria Government Gazette

Sewerage Area No. 7848

Shire of Cranbourne—This area comprises Lots 187 to 194, a municipal reserve, Lots 195 to 202, a municipal reserve, Lots 203 to 207, a municipal reserve, Lots 208 to 213 Victor Court, All Lots in Ballina Place, Lots 154 to 158, 164 to 166, 178 to 181, 216 to 224 Strong Drive, All Lots in Gandin Court, Lots 153 to 148 Gleneadie Close, Lots 182 to 191, a municipal reserve, Lots 192 to 199, 210 to 215 Ellindale Close, All Lots in Kendari Court, and contains 103 lots.

Sewerage Area No. 7850

Shire of Cranbourne—This area comprises Lots 61 to 53, 24 to 27, 50 Cumberland Chase, Lots 49 to 42, 35 to 28 Kiandra Mews, Lots 1, 3 to 11, a reserve, Lots 12, 13, 300 to 288, 227, 238, 239, 255, 258 to 261, 16 to 23, 52, 51 Ralph Crescent, Lot 2 Burlington Chase, Lots 262 to 268 The Ridge, All Lots in Greenhill Rise, All Lots in Bill Place, Lots 256, 257 Laura Drive, Lots 175 to 191 Thelma Rise, All Lots in Cornell Place, Lots 209 to 196 Acre Rise, Lots 603, 604 Lesley Drive, and contains 162 lots.

Sewerage Area No. 7855

Shire of Cranbourne—This area comprises Lots 126 to 123 Alpha Close, Lots 122 to 115 Dewpoint Crescent, Lots 114 to 109 The Spur, Lots 91 to 84, 139 to 141, a municipal reserve, Lots 210, 162 Horizon Boulevard, and contains 31 lots.

Sewerage Area No. 7838

City of Oakleigh—This area comprises Lots 1, 2, 1 to 6 Huntingdale Road, and contains 8 lots.

Sewerage Area No. 7842

City of Springvale—This area comprises Lot 1 Malcolm Road, and contains 1 lot.

Sewerage Area No. 7845

City of Springvale—This area comprises Lots 58 to 89 Dunscombe Place, and contains 32 lots.

Sewerage Area No. 7847

City of Springvale—This area comprises Lots 67 to 76, 4 to 11, 26, 27 Bianca Drive, Lots 1, 1 to 3 Wells Road, Lots 30 to 35 Lynda Court, All Lots in Helmich Court, and contains 44 lots.

Sewerage Area No. 7858

City of Springvale—This area comprises Lots 1 to 20 Lagoon Place, and contains 20 lots.

Further particulars may be obtained from Melbourne Water's Moorabbin Office, South East Region.

By Order of

**MATTHEW GIESEMANN**  
Development Manager  
Moorabbin Office  
South East Region

20494

**MELBOURNE WATER**  
Proclamation of Water Mains

Notice to the owners of tenements in the undermentioned street and the private streets, lanes, courts and alleys opening thereto. The main pipe in the said streets being laid down, the owners of all tenements situated as under are hereby required on or before 2 August 1992 to cause a proper pipe and stop-cocks to be laid so as to supply water within such tenements from the main pipe.

**BERWICK**

Kurrajong Road, from the southwest boundary of Lot 40, eastward 280 metres.

Ellinvale Drive, from Kurrajong Road, northeastward 35 metres.

Nettle Drive, from the northwest boundary of Lot 23, westward 262 metres.

Louise Court, the whole court, 65 metres.

Simone Court, the whole court, 77 metres.

Fitzgerald Road, from Nettle Drive, southward 38 metres.

George Bass Avenue, from David Collins Drive, northeastward 224 metres.

Edward Freeth Drive, from George Bass Avenue, eastward 283 metres.

Morgan Court, the whole court, 66 metres.

Reema Boulevard, from the northeast boundary of Lot 233, southward 103 metres.

Aranmore Crescent, from the southwest boundary of Lot 31, northward 38 metres.

Lana Place, the whole place, 93 metres.

Naomi Court, the whole court, 93 metres.

Miriam Close, the whole close, 75 metres.

Anaconda Road, from Maramba Drive, northeastward 129 metres.

Maramba Drive, from the southwest boundary of Lot 230, eastward then southward 379 metres.

Tarcoola Drive, from Maramba Drive, eastward 37 metres.

Edrington Park Drive, from the southwest boundary of Lot 105, eastward 137 metres.

Jancoi Court, the whole court, 95 metres.

Aristotle Court, the whole court, 169 metres.

Godwin Avenue, from Kurrajong Road, eastward 89 metres.

Kurrajong Road, from the southwest boundary of Lot 250, northward 90 metres.

Edrington Park Drive, from Melville Park Drive, eastward 109 metres.

Melville Park Drive, from the northwest boundary of Lot 124, southward 71 metres.

James Bathe Way, from the northeast boundary of Lot 142, southwestward 135 metres.

Boomerang Court, from James Bathe Way, southeastward 39 metres.

Rupertswood Rise, the whole rise, 105 metres.

Clivenden Close, the whole close, 92 metres.

Ernst Wanke Road, from Narre Warren Road, westward 216 metres.

London Crescent, from the northwest boundary of Lot 76, eastward 184 metres.

Sidney Court, the whole court, 114 metres.

James Court, the whole court, 109 metres.

Leonard Avenue, the whole avenue, 378 metres.

Magdalena Place, the whole place, 157 metres.

Sunnyside Drive, the whole drive, 355 metres.

Adelaide Drive, the whole drive, 172 metres.

The Gateway, from the southwest boundary of Lot 610, eastward 380 metres.

Emma Court, the whole court, 166 metres.

Theodore Terrace, the whole terrace, 205 metres.

Gumnut Court, the whole court, 188 metres.

Perennial Road, the whole road, 196 metres.

Oscar Court, the whole court, 79 metres.

Coolong Avenue, the whole avenue, 317 metres.

Messmate Court, the whole court, 211 metres.

Boree Court, the whole court, 245 metres.

Wimmera Court, the whole court, 311 metres.

Coowarra Way, from Wimmera Court, eastward 52 metres.

**CRANBOURNE**

South Gippsland Highway, from the southeast boundary of lot 3, northwestward 240 metres.

1636 G 25 1 July 1992

SPRINGVALE

Wells Road, from McLeod Road, southward, 86 metres.

Wells Road, from Bianca Drive, eastward 92 metres.

Bianca Drive, from Wells Road, southward, then southeastward 253 metres.

Helmich Court, the whole court, 176 metres.

Springvale Road, from the northeast boundary of Lot 7, northward 570 metres.

KNOX

Dunlop Court, the whole Court, 267 metres.

Further particulars may be obtained from Melbourne Water's Moorabbin Office, South East Region.

By order of  
MATTHEW GIESEMANN  
Development Manager  
Moorabbin Office  
South East Region

20494

Victoria Government Gazette

(i) Devenish Waterworks District;

(ii) Devenish Urban District.

6. The Benalla Water Board Electoral District shall be extended to include the Devenish Water Board Electoral District.

7. The Former Authority is abolished.

(a) This is an Order referred to in section 98 (2) (a) of the Act.

(b) Under section 100 (2) (a) of the Act, the affected Authorities have applied to me for the Order to be made.

(c) Under section 98 (2) (a) of the Act I have agreed to the terms and conditions for the takeover made by this Order with the affected Authorities.

Dated 24 June 1992

DAVID DOWNIE

Director-General of Water Resources  
as delegate of the Minister for Water

Resources

21210

WATER ACT 1989

I, David Downie, Director-General of Water Resources, as delegate of the Minister for Water Resources made the following Order:

APPOINTMENT OF THE BENALLA WATER BOARD ORDER 1992

1. This Order is called the Appointment of the Benalla Water Board Order 1992.

2. The Order is made under the powers conferred by Division 2 of Part 6 of the *Water Act 1989* and all other available powers.

3. This Order takes effect on 1 July 1992.

4. In this Order—

“Act” means the *Water Act 1989*;

“Authority” means the Benalla Water Board constituted by an Order in Council dated 27 September 1983;

“Former Authority” means the Devenish Water Board constituted by an Order in Council dated 13 December 1983.

5. On and from the date on which this Order takes effect—

(a) The Authority takes over the whole of the property, rights, liabilities, obligations, powers and functions under the Act of the former Authority including the management and control of the existing water districts named below:

MELBOURNE WATER

Notice of Preparation of Regulatory Impact Statement

In accordance with the provisions of the *Subordinate Legislation Act 1962*, notice is given of the proposal to make the following Regulation:

By-law No. 294: Waterways By-law

The proposed Regulation replaces existing By-laws Nos 239, 264, 265 and 291.

The objectives of the proposed statutory rule are to ensure the proper conduct of activities and safety of users on certain waterways under the control of Melbourne Water by:

Regulating boat traffic and other activities.

Providing for the licensing of boats which are moored.

Providing for the licensing of passenger tourist boats and other boats which are let out for hire.

Providing for the regulation of structures in or above the waterway.

The Schedule to the By-law contains fee structures for mooring, passenger tourist boat and hire-and-drive business licences. The fees are based on the user-pays principle and are aimed at full cost recovery.

The Regulatory Impact Statement concludes that the proposed Regulation is the most appropriate means of achieving the objectives.

*Victoria Government Gazette*

The proposed By-law and Impact Statement will be on exhibition from 1 to 31 July 1992.

Water-based Uses Policy for the Lower Yarra and Maribyrnong rivers.

A Water-based uses policy for the lower Yarra and Maribyrnong rivers will be placed on exhibition concurrently with the proposed By-law. The policy contains sections on environmental management, safety and risk management, use of the river, mooring of boats and promotion.

Further information and copies of the Regulatory Impact Statement, the proposed Regulation and proposed policy document are available from Colin Leigh or Peter Zimmermann, Parks and Waterways Planning Division, Melbourne Water, 625 Little Collins Street, Melbourne 3000. Telephone 615 5208 or 615 4309.

Copies can also be obtained from Melbourne Water's Maribyrnong Regional Office, St Albans Road, Sunshine and Yarra Regional Office, Lucknow Street, Mitcham.

Written comments and submissions are invited from the public and should be lodged at the above address no later than 31 July 1992. 20490

**WATER ACT 1989**

I, Mark Anderson, Director, Water Industry Management, as delegate of the Minister for Water Resources make the following Order:

**APPOINTMENT OF THE MID-GOULBURN REGIONAL WATER BOARD ORDER (No. 1) 1992**

1. This Order is called the Appointment of the Mid-Goulburn Regional Water Board Order (No. 1) 1992.

2. This Order is made under the powers conferred by Division 2 of Part 6 of the *Water Act 1989* and all other available powers.

3. This Order takes effect on the date of its publication in the *Government Gazette*.

4. In this Order—

“Act” means the *Water Act 1989*.

“Former Authority” means the Marysville Water Board constituted by an Order in Council dated 29 May 1984.

5. On and from the date on which this Order takes effect—the Mid-Goulburn Regional Water Board is appointed to take over the whole of the property, rights, liabilities, obligations, powers

G 25 1 July 1992 1637

and functions under the Act of the Former Authority including the management and control of the existing water districts named below—

Marysville Urban District

Marysville Waterworks District

6. The Mid-Goulburn Regional Water Board takes over the staff of the Former Authority from the date of this Order.

7. From 1 July 1992 the Mid-Goulburn Regional Water Board Electoral District is extended to include the Marysville Water Board Electoral District.

8. On and from the date on which this Order takes effect, the current membership of the Mid-Goulburn Regional Water Board is not altered.

9. The Former Authority is abolished.

10. (a) This is an Order referred to in section 98 (2) (a) of the Act.

(b) Under section 100 (2) (a) of the Act, the affected Authorities Mid-Goulburn Regional Water Board and Marysville Water Board have applied to me for the Order to be made.

(c) Under section 98 (2) (a) of the Act I have agreed the terms and conditions for the takeover made by this Order with the affected Authorities.

Dated 29 June 1992

MARK ANDERSON  
Director—Water Industry Management  
as delegate of the  
Minister for Water Resources

21210

*Planning and Environment Act 1987*  
**CAMBERWELL PLANNING SCHEME**  
Notice of Lapsing of Amendment  
Amendment L5

On 10 April 1992 the City of Camberwell resolved to abandon the above amendment.

The amendment proposed to change the zoning of part of the land in the existing reservation covering “Froggnal”, 54 Mont Albert Road, Canterbury, from Public Purposes 1 (Commonwealth Government) to Camberwell Residential zone.

The amendment lapses on the date this notice is published in the *Government Gazette*.

GEOFF CODE  
Manager  
20600 Planning Co-ordination Branch

1638 G 25 1 July 1992

*Planning and Environment Act 1987*  
WERRIBEE PLANNING SCHEME  
Notice of Lapsing of Amendment  
Amendment L35

The City of Werribee has resolved to abandon the above amendment.

The amendment proposed to rezone from Corridor A to Residential D the following land at Little River—

the area south of Jolyn Court between Rothwell Road and the Little River;

the area south of Flinders Street between Rothwell Road and McLeans Road;

the area bounded by Old Melbourne Road, Gleasons Road and the Little River;

the triangular piece of land between Little River Road and the railway line.

The amendment lapses on the date this notice is published in the *Government Gazette*.

GEOFF CODE  
Manager

20600 Planning Co-ordination Branch

*Planning and Environment Act 1987*  
ST KILDA PLANNING SCHEME  
Notice of Amendment  
Amendment L18

The Minister for Planning and Housing has prepared this amendment to the local section of the St. Kilda Planning Scheme.

The amendment makes minor changes (for the purpose of clarification) to the Consent Notice applicable to the redevelopment of the Sea Baths site, Jacka Boulevard, City of St. Kilda, for the purpose of a health and fitness centre incorporating hot sea baths, swimming pool and other related activities.

The amendment and the consent notice can be inspected at the offices of the Department of Planning and Housing, Ground Floor, 477 Collins Street, Melbourne and the City of St. Kilda, corner Brighton Road and Carlisle Street, St. Kilda.

GEOFF CODE  
Manager

20600 Planning Co-ordination Branch

*Victoria Government Gazette*

*Pipelines Act 1967, No. 7541*

DEPARTMENT OF MANUFACTURING  
AND INDUSTRY DEVELOPMENT

Application for a Permit to Own and Use a Pipeline

1. In accordance with the provisions of section 11 (1) of the *Pipelines Act 1967*, notice is given that an application has been received by me from the Gas and Fuel Corporation of Victoria for a Permit to Own and Use a Pipeline for the purpose of conveying natural gas at Port Melbourne.

2. The proposed route of the pipeline is as follows:

A steel pipeline approximately 0.44 kms in length with a nominal bore of 150 mm and commencing at a branch valve on the South Melbourne to Brooklyn pipeline (Authorised under Permit No. 108) located within the Bay Street Road Reserve adjacent to the south western corner of its intersection with Boundary Street, Port Melbourne, thence proceeding in a generally north easterly direction within the Bay Street Road Reserve for a distance of approximately 15 metres to the southern side of Boundary Street, thence turning to continue in a generally north westerly direction along the southern side of such street for a distance of approximately 410 metres, crossing Station-Gladstone Street, the Port Melbourne Light Rail, Normanby Road and Munro Street en route, thence turning to continue in a generally south westerly direction for a distance of approximately 20 metres to leave the Boundary Street Road Reserve to enter property owned by Unilever (Australia) Pty Ltd and known as Allotments 15 and 16 Parish of South Melbourne, County of Bourke, and terminate at a line valve situated adjacent to the western boundary of such allotment.

3. Plans of the proposed route of the pipeline may be inspected between the hours of 9.00 a.m. and 4.00 p.m. Mondays to Fridays (excluding public holidays) at the Department of Manufacturing and Industry Development, Energy Division, 6th Floor, 151 Flinders Street, Melbourne; Council Offices, City of Port Melbourne, Bay Street, Port Melbourne; Council Offices, City of South Melbourne, Bank Street, South Melbourne; Gas and Fuel Corporation of Victoria, 171 Flinders Street, Melbourne.

*Victoria Government Gazette*

Additional copies of plans are not available from the Department and preliminary route plans can be seen only at Gas and Fuel Corporation of Victoria, 171 Flinders Street, Melbourne.

4. Any objection to the proposed route of the pipeline must be addressed to me and reach my office at the Department of Manufacturing and Industry Development, 228 Victoria Parade, East Melbourne, 3002, no later than Friday, 7 August 1992.

Dated 29 June 1992

DAVID WHITE  
Minister for Manufacturing and  
Industry Development  
20400

*Health Services Act 1988*  
DECLARATION OF COMMUNITY  
HEALTH CENTRE

I, I. Weibgen, Acting Regional Director, Loddon-Campaspe Mallee Region, Health Department Victoria, as delegate for the Chief General Manager being satisfied as to the matters referred to in paragraphs (a) and (b) of section 45 (1) of the Act, declare under that section—

- (i) the Northern District Community Health Service Incorporated to be a community health centre; and
- (ii) the area specified below to be the area served by the Northern District Community Health Service Incorporated.

Kerang (Shire)

That portion bounded by the Loddon Valley Highway, Shire of Gordon/Kerang boundary, Meering West Road, Dear Road, Weir Road, Baulch Road, Normanville Road, Manuel Road, Brady Lane, Lalbert/Kerang Road, Gillies Road, O'Brien Road, Loughran Road, Shire of Kerang/Swan Hill boundary.

East Loddon (Shire)

That portion bounded by the Loddon Valley Highway, Prairie West Road, Shire of East Loddon/Rochester boundary.

Gordon (Shire)

That portion bounded by the Shire of Gordon/Rochester boundary.

G 25 1 July 1992 1639

Rochester (Shire)

That portion bounded by Balderson Road, Gunbower Road, Gibbon Road, the National Channel, Baggot's Creek, Murray River.

Where any road, street, lane or thoroughfare forms part of the boundary of the catchment area common to another centre, the centre line of the road, street, lane or thoroughfare shall be deemed to be the boundary and the area north or east (whichever is applicable) of the centre line is deemed to be the catchment area.

IAN WEIBGEN  
20370 Acting Regional Director

*Health Services Act 1988*  
DECLARATION OF COMMUNITY  
HEALTH CENTRE

I, I. Weibgen, Acting Regional Director, Loddon-Campaspe Mallee Region, Health Department Victoria, as delegate for the Chief General Manager in accordance with section 45 (2) of the *Health Services Act 1988* vary the area served by the Wheatlands Community Health Centre Incorporated and declare that the area specified below to be the area served by the centre.

Kerang (Shire)

That portion bounded by O'Meara Road, Meatian Road, Loughran Road, Gillies Road, Lalbert/Kerang Road, Brady Lane, Manuel Road, Normanville Road, Baulch Road, Weir Road, Dear Road, Meering West Road, Forest Lane, Sutherlands Road, Teasedales Road.

Gordon (Shire)

That portion bounded by the Loddon Valley Highway, Gordon/Korong Shire boundary, Charlton/Gordon Shire boundary.

Wycheproof (Shire)

That portion bounded by the Charlton/Wycheproof Shire boundary, Charlton/Thalia Road, Morton Plains Road, Wycheproof/Birchip Shire boundary, Birchip Road, Springfield Road, Powers Road, Lalbert Creek, Matiskes Tank Road.

Where any road, street, lane or thoroughfare forms part of the boundary of the catchment area common to another centre, the centre line of the road, street, lane or thoroughfare shall be deemed to be the boundary and the area south or west (whichever is applicable) of the centre line is deemed to be the catchment area.

1640 G 25 1 July 1992

The Wheatlands Community Health Centre Incorporated was formerly known as the Quambatook Community Care Centre.

The Quambatook Community Care Centre was declared a community health centre and the area specified below to be the area served by the centre, in the *Government Gazette* of 18 October 1989.

The western part of the Shire of Kerang bounded by Crump Road, Flemming Road, Barraport Road, Meering West Road, White Elephant Road, Fawcett Lane, Fenton Lane, Lalbert/Kerang Road, Lookout Road, and Meatian/Mystic Park Road.

IAN WEIBGEN  
Acting Regional Director

20370

*Health Services Act 1988*  
DECLARATION OF COMMUNITY  
HEALTH CENTRE

I, I. Weibgen, Acting Regional Director, Loddon-Campaspe Mallee Region, Health Department Victoria, as delegate for the Chief General Manager being satisfied as to the matters referred to in paragraphs (a) and (b) of section 45 (1) of the Act, declare under that section—

- (i) the Echuca Regional Community Health Centre Incorporated to be a community health centre; and
- (ii) the area specified below to be the area served by the Echuca Regional Community Health Centre Incorporated.

City of Echuca  
Shire of Deakin

The north western part of the Shire of Deakin bounded by Curr Road, O'Dea Road and Shackell Road.

Shire of Rochester

The Shire of Rochester excluding that part bounded by the Shire boundaries and Balderson Road, Gunbower Road, Gibbon Road, the National Channel and Baggot's Creek.

IAN WEIBGEN  
Acting Regional Director

20370

*Victoria Government Gazette*

ROAD SAFETY (VEHICLES)  
REGULATIONS 1988

General Dimension Permit for Over Length  
Semi-Trailers

Regulation 724 of the Road Safety (Vehicles) Regulations 1988 authorises the Roads Corporation, by notice in the *Government Gazette*, to allow vehicles and loads which exceed mass or dimension limits prescribed in the Regulations to be used on highways.

In accordance with those Regulations, I, Tony Fry, delegate of the Roads Corporation, allow the semi-trailers specified in Part 1 of the following schedule which are within the dimension limits specified in Part 2 to be used on the highways specified in Part 3 on condition that they are operated in accordance with Part 4.

This notice is valid until 31 December 1994.  
Dated 23 June 1992

TONY FRY  
Manager  
Policy Development Department  
VicRoads

The Schedule

Part 1—Specified Vehicles

1.1 *Specified Vehicles*

This General Dimension Permit applies to semi-trailers exceeding 12.5 metres in length to a maximum of 13.7 metres over the full width of the vehicle.

Part 2—Dimension Limits

2.1 *Dimension Limits*

The length limits of a semi-trailer on a highway may exceed the limits specified in the Road Safety (Vehicles) Regulations 1988 Section 716 (2) (a) and (b) provided the maximum dimensions of semi-trailers as specified in the Australian Design Rule 43/02 are not exceeded.

Part 3—Specified Highways

3.1 *Specified Highways*

The semi-trailers are authorised to operate on the following highways:

- (a) over a state highway, a main road, a tourists' road, a forest road and a freeway (all as defined in section 2 (1) of the *Transport Act 1983*) and over highways between those highways; and



- (b) over a highway, in a municipality specified by the Minister for Transport by notice in the *Government Gazette* where the journey is not undertaken entirely within that municipality; and
- (c) with, and in accordance with, the approval of a municipality specified in accordance with paragraph (b), over a highway in that municipality, where the journey is undertaken entirely within that municipality.

## Part 4—Specified Conditions

## 4.1 Operating Conditions for the Vehicle

## 4.1.1 Complying with Total Length Limits

Owners of semi-trailers exceeding 12.5 metres in length must ensure that any drivers using these semi-trailers are aware that they are coupling to a longer semi-trailer.

## 4.1.2 Sign Posted Limits

Travel is not permitted on a highway where any sign posted dimension limit would be exceeded. 20703

*Workers Compensation Act 1958*  
NOTICE OF NEW BENEFIT RATES  
PAYABLE IN ACCORDANCE WITH  
SECTION 9 AND SECTION 11

## (a) Section 9

Section 9 (3) of the *Workers Compensation Act 1958* provides for rates of compensation to be adjusted on 1 July in any year in line with movements in the Australian male average weekly earnings between the December quarters of the two preceding years, as published by the Australian Statistician at 15 June in each respective year.

The Australian Statistician no longer publishes average weekly earnings figures for the December quarter. Therefore the Australian average weekly earnings for all males for the November quarter are used.

The Australian male average weekly earnings for the November quarter of the years 1990 and 1991 are \$578.20 and \$589.70 respectively.

Notice is hereby given that calculations in accordance with the said section produce the following rates of compensation which are payable, on and from 1 July 1992 instead of the amounts specified in section 9 of the said Act, in the clauses under the heading "The Clauses Referred to".

	<i>The amount specified in "The Clauses Referred to" (wherever amount to operate occurring)</i>	<i>The adjusted amount to operate from 1 July 1992</i>
	\$	\$
1. (a) (i)	33 160	91 500
	8 088	22 321
	7 566	20 876
	7 044	19 437
	6 523	17 998
	6 001	16 558
	5 479	15 118
	4 957	13 678
	4 435	12 237
	3 914	10 802
	3 392	9 359
	2 870	7 918
	2 348	6 477
	1 826	5 038
	1 826	5 038
1. (a) (ii)	33 160	91 500
1. (b) (i)	105	290
	30	81
	10	28
	155	430
	78	214
	135	371
1. (b) (iii)	36 960	101 985

## (b) Section 11

Section 11 (1) of the *Workers Compensation Act 1958* provides for rates of compensation for certain specified injuries to be set percentages of the maximum payable, at the time of injury, under Clause 1 (a) (ii) as from 1 July 1992.

J. G. EDGAR  
20290 Acting Director General

Creditors, next of kin and others having claims against the estate of any of the under-mentioned deceased persons are required to send particulars of their claims to the State Trust Corporation of Victoria, 168 Exhibition Street, Melbourne Vic. 3000, the personal representative, on or before 21 July 1992 after which date the State Trust Corporation may convey or distribute the assets having regard only to the claims of which the State Trust Corporation then has notice.

Beardshall, George Francis, in the will called George Beardshall, late of 24 Colour Road, Diggers Rest, retired telecom employee, died 29 October 1991.

1642 G 25 1 July 1992

Burt, Violet Elizabeth, late of Unit 4, 448 Monbulk Road, Tecoma, widow, died 7 January 1992.

Frese, Lottie, late of Alberta House Accommodation Home, 241 Dandenong Road, Windsor, pensioner, died 3 March 1992.

Gunn, Elizabeth, late of Castlemaine, pensioner, died 15 February 1992.

Johnson, Gertrude Stuart Josephine, also known as Gertrude Josephine Johnson, late of 17 Jolimont Road, Forest Hill, retired, died 13 December 1991.

Kerr, Ada Evelyn, formerly of 1 Thorpdale Street, East Newborough, but late of Unit 79, Yallambie Village, Traralgon, home duties, died 12 October 1991.

Noll, Antoinette Therese, late of 12 Alvie Court, West Meadows, home duties, died 16 October 1985.

Sluiter, George, late of 8 Keogh Street, Rosebud, retired, died 2 December 1991.

Terzini, Quirino, late of Toorak House Nursing Home, 1011 Toorak Road, Camberwell, pensioner, died 3 November 1991. Dated at Melbourne 12 May 1992

B. F. CARMODY  
Managing Director  
State Trust Corporation

20434

Creditors, next of kin and others having claims against the estate of any of the under-mentioned deceased persons are required to send particulars of their claims to the State Trust Corporation of Victoria, 168 Exhibition Street, Melbourne, the personal representative, on or before 28 July 1992 after which date the State Trust Corporation may convey or distribute the assets having regard only to the claims of which the State Trust Corporation then has notice.

Andrews, Percy Thomas Beech, late of 26 Anderson Street, Pascoe Vale, retired, died 1 October 1991.

Bagot, Francis Ivor, late of "Little Haven" 3 Smeaton Avenue, Hoppers Crossing, Agricultural Officer, died 14 February 1992.

Bezzina, Anthony, late of 155 Myers Street, Geelong, pensioner, died 20 October 1991.

Coleman, Edith Frances, formerly of 10 Closeburn Avenue, Windsor, but late of Athol Lodge, 41 Acland Street, St. Kilda, widow, died 8 March 1992.

Victoria Government Gazette

Curren, Florence, late of Carnsworth Garoopna Nursing Home, 18 Barry Street, Kew, pensioner, died 7 February 1992.

Dean, Myrtle Beatrice, formerly of Unit 8, 186 Princes Highway, Hallam, but late of Chelsea Park Private Nursing Home, 55-57 Broadway, Chelsea, pensioner, died 25 February 1992.

Fergus, Patrick Anthony, late of 24 Dalgety Street, St. Kilda, pensioner, died 2 November 1991.

Gilbert, Elizabeth Selina, also known as Elizabeth Gilbert, formerly of 172 Beavers Street, Northcote, but late of 14 Como Street, Alphington, widow, died 13 August 1991.

Hallvorsen, Gunnar, late of 66 Numurkah Road, Shepparton, pensioner, died 18 October 1991.

Hornsby, Stanley Thomas, late of 106 River Street, Newport, retired, died 20 April 1985.

Knezevic, Lazar, formerly of 4 Ridgeway Street, Kensington, but late of 57/150 Inkerman Street, East St. Kilda, pensioner, died 29 January 1992.

Lowe, Shirley Jean, late of 2/6 Alexandra Road, Ringwood East, widow, died 29 February 1992.

Nilan, Winifred Ivy, formerly of 87 Eskdale Road, Caulfield, late of 28 White Street, Mount Waverley, spinster, died 17 February 1992.

Spry, Evelyn Grace, formerly of 43 Bennett Parade, East Kew, but late of Glenferrie Private Nursing Home, 31 Chrystobel Street, Hawthorn, widow, died 8 February 1992.

Stanford, Eleanor Fearey, formerly of 27 Cole Street, Laverton, but late of Wyndham Lodge, 120 Synnot Street, Werribee, widow, died 18 February 1992.

Tarnay, Geza, late of 20 Devon Street, Heidelberg, pensioner, died 19 March 1992. Dated at Melbourne 19 May 1992

B. F. CARMODY  
Managing Director  
State Trust Corporation

20434

Creditors, next of kin and others having claims against the estate of any of the under-mentioned deceased persons are required to send particulars of their claims to the State Trust Corporation of Victoria, 168 Exhibition Street, Melbourne, the personal representative, on or before 13 July 1992 after which date the State Trust Corporation may convey or distribute the

*Victoria Government Gazette*

assets having regard only to the claims of which the State Trust Corporation then has notice.

Claffey, Noreen Newton, formerly of Unit 7, 34 Barkly Street, St. Kilda, late of Otway Pioneer Nursing Home, Corangamite Street, Colac, retired teacher, died 9 January 1992.

Dean, Carol Grazia, formerly of 18 Gabriel Avenue, Chadstone, late of Kimberley Nursing Home, 42 Mentone Parade, Mentone, stenographer, died 20 March 1992.

Jones, Charles William, late of 3 Zinnia Street, Reservoir, retired, died 26 December 1991.

Key, William Ronald, late of 19 Bon Vue Road, North Balwyn, retired, died 15 January 1992.

Kiesel, Antoni, also known as Antoni Kieslel and Antoni Kieseil, late of 10 Leander Street, Footscray, retired, died 15 July 1991.

Langtip, Graeme Ernest, formerly of 95 Westbourne Grove, Northcote, late of Burke Lodge, 6 Burke Road, Malvern, retired serviceman, died 14 November 1991.

Marshman, Stanley William, late of Kew Cottages, Princes Street, Kew, pensioner, died 6 February 1992.

Montgomery, John James, late of 26 Third Avenue, Hoppers Crossing, pensioner, died 11 January 1992.

Peace, Roberta, late of Greenview Special Accommodation House, 27-29 The Greenway, Heathmont, pensioner, died 3 August 1991.

Purins, Janis, late of 67 Tranmere Avenue, Carnegie, pensioner, died 16 August 1991.

Rooney, Thomas, late of 21 Dega Avenue, East Bentleigh, retired electrical, died 30 January 1992.

Ryan, John Bernard, late of Alexandra Rest Home, 503 Cross Road, Plympton, South Australia, retired gardener, died 23 June 1991.

Stewart, John Maurice, late of 3 New Street, Kew, retired, died 20 October 1991.

Watson, Janet, formerly of Castlebar Special Accommodation House, 16 Castlebar Road, Chadstone, late of Corner Blackburn and Canterbury Roads, Blackburn, widow, died 29 September 1991.

West, Leonard Gordon, late of 31 Hopetoun Avenue, Canterbury, retired, died 4 April 1992.

White, David Thomas, formerly of Unit 4, 25 Lake Street, Reservoir, late of Lumeah Nursing Home, 78 Bruce Street, Preston, widower, died 2 February 1992.

G 25 1 July 1992 1643

Dated at Melbourne 4 May 1992

20434

B. F. CARMODY  
Managing Director  
State Trust Corporation

Creditors, next of kin and others having claims against the estate of any of the under-mentioned deceased persons are required to send particulars of their claims to the State Trust Corporation of Victoria, 168 Exhibition Street, Melbourne Vic. 3000, the personal representative, on or before 31 August 1992, after which date the State Trust Corporation may convey or distribute the assets having regard only to the claims of which the State Trust Corporation then has notice:

Bundy, Harold Edward, late of 32 Market Street, Kyneton, labourer, died 21 August 1991.

Cunningham, Frederick Laurence, also known as Frederick Lawrence Cunningham, late of Flat 5, 43 Holland Court, Flemington, retired horse trainer, died 29 December 1991.

Dienhoff, Veronica Brigita, late of Flat 10, 7 Denbigh Road, Armadale, secretary, died 6 February 1992.

Adonnelly, Adeline Matilda Victoria, formerly of Yarragon, late of 11 Grandview Grove, Carnegie, pensioner, died 19 April 1992.

Freake, Elizabeth May, late of Beechworth, pensioner, died 23 September 1991.

Freeman, Alice, late of Begonia Private Nursing Home, Ballarat, pensioner, died 15 March 1992.

Heaps, Harry, formerly of Bulla Road, Tullamarine, late of 372 Melrose Drive, Tullamarine, poultry farmer, died 26 March 1992.

Henderson, Donald Arthur, late of 44 Sandford Avenue, Sunshine, retired, died 3 May 1992.

Lagaard, Arnold Christian, also known as Arnold Lagaard, late of 253 MacKenzie Street, Bendigo, retired painter, died 28 June 1990.

Lenowry, Irene Gertrude, formerly of 17 Flowers Street, South Caulfield, late of Alexandra Private Nursing Home, 304 Hawthorn Road, Caulfield South, widow, died 5 January 1992.

Lloyd, Annie, late of 2 Newman Street, Sunshine, pensioner, died 8 May 1992.

Lynch, Robert Thomas, late of Ararat, pensioner, died 10 July 1991.

1644 G 25 1 July 1992

Mehmet, Esma Aileen, formerly of Flat 3/21 McLennan Place, East Preston, late of St. Aidans Nursing Home, 79 Mansfield Street, Thornbury, pensioner, died 5 April 1992.

Molyneux, John Marni, formerly known as John Mahony, late of 24 Cumming Street, Brunswick West, retired, died 22 October 1991.

Carter, Felicity Estelle, late of Kew Cottages, Kew, pensioner, died 22 November 1991.

Court, Walter George, late of 74 Cardinal Road, Glenroy, service pensioner, died 4 February 1992.

Dart, Stewart, also known as Stuart Alan Oart, late of Flat 1, 31 Murphy Street, Gardenvale, retired, died 3 January 1992.

Denny, Dorothea Isobel, late of Latrobe Private Nursing Home, 14 Como Street, Alphington, pensioner, died 8 May 1992.

Torney, Shirley Winifred, late of 5 Thomas Street, Airport West, home duties, died 16 March 1992.

MacPherson, Colin Clyde, late of 24 Pratt Avenue, Frankston, chemical maker, died 7 April 1992.

McMahon, Robert John, formerly of 13 Blyth Street, Vermont, late of 10 Carnavon Street, Lang Lang, marketing manager, died 1 August 1991.

Rigon, Margherita, late of Beechworth, pensioner, died 24 April 1992.

Robins, James Henry, late of Cuming Street, Yarraville, retired postal supervisor, died 24 March 1992.

Sieben, Veronica Anne, late of "Hampton House", 158 Ludstone Street, Hampton, widow, died 13 June 1992.

Thomas, Alan Raymond, late of 36 Hedge-End Road, Mitcham, unemployed, died 30 April 1992.

White, Shirley, formerly of 22 Francis Crescent, Glen Iris, late of Nicol Road, Koondrook, married woman, died 8 September 1991.

Williams, Claude Frederick, late of Carnsworth Private Nursing Home, 10 A Beckett Street, Kew, retired, died 24 February 1992.

Dated 22 June 1992

B. F. CARMODY  
Managing Director  
State Trust Corporation

20434

*Victoria Government Gazette*

*Fisheries Act 1968*

FISHERIES NOTICE No. 8/1992

I, Barry Pullen, Minister for Conservation and Environment, after consultation with the Victorian Fishing Industry Federation, make the following Fisheries Notice:

Dated 28 June 1992

BARRY PULLEN

Minister for Conservation and Environment

FISHERIES (GIPPSLAND LAKES MUSSEL FISHERY) (No. 2) NOTICE 1992

Title

1. This notice may be cited as the Fisheries (Gippsland Lakes Mussel Fishery) (No. 2) Notice No. 8/1992.

Commencement

2. This notice comes into operation on the date of this notice.

Objective

3. The objective of this notice is to control the taking of mussels from mussel beds located in the Gippsland Lakes for a period of three months.

Authorising Provision

4. This notice is made under section 80 of the *Fisheries Act 1968*.

Definitions

5. In this notice:

"Diving Equipment" means equipment which is specifically designed to assist breathing while the user is wholly or partly submerged in water and includes breathing regulators, S.C.U.B.A. equipment, equipment which is capable of pumping air to a regulator and snorkels.

"Fish Bin" means a fish bin with a nominal capacity of 54.5 litres.

Hours of Operation for Taking Mussels

6. The holder of a licence to take mussels for sale from the Gippsland Lakes must not take mussels from the waters of the Gippsland Lakes other than between the hours of 7.00 a.m. and 4.30 p.m. on any Monday.

Catch Limit

7. The holder of a licence to take mussels from the Gippsland Lakes must not take, store, hold or possess more than a total of 210 kilograms of mussels on any one day.

8. The holder of a Master Fisherman's Licence—

- (a) must ensure that mussels are cleaned within 20 metres of the point where the mussels were harvested; and
- (b) must ensure that other than when using a catch bag while diving, mussels are only contained in fish bins; and
- (c) must not be in possession of more than 7 full or partly filled fish bins containing mussels; and
- (d) must be present while mussels are taken; and
- (e) must ensure that diving equipment is not used from the master fisherman's boat other than between the hours of 7.00 a.m. and 4.30 p.m. on any Monday.

Penalty

9. Any person who contravenes this notice is liable to a penalty of 20 penalty units. 20090

*Fisheries Act 1968*

FISHERIES NOTICE No. 9/1992

I, Barry Pullen, Minister for Conservation and Environment, after consultation with the Victorian Fishing Industry Federation, make the following Fisheries Notice:

Dated 26 June 1992

BARRY PULLEN

Minister for Conservation and Environment

FISHERIES (SHARK FISHING) (No. 2)  
NOTICE 1992

*Title*

1. This notice may be cited as the Fisheries (Shark Fishing) (No. 2) Notice No. 9/1992.

*Commencement*

2. This notice comes into operation on the date of this notice.

*Objective*

3. The objective of this notice is to prohibit the commercial targeting of shark in all Victorian waters other than Port Phillip Bay, Western Port and Corner Inlet as a consequence of State and Commonwealth management arrangements.

*Authorising Provision*

4. This notice is made under section 80 of the Fisheries Act 1968.

*Certain Shark Gillnets and Longlines Not to be Used*

5. (1) A person must not use in Victorian waters during the period commencing on the date of this notice and ending on 25 September 1992—

- (a) any mesh net containing any meshes measuring greater than 150 millimetres;
- (b) any one line or combination of lines with more than 200 hooks attached where the mainline is of a sinking rope with a diameter of 6 millimetres or more.

(2) The provisions of sub-clause (1) do not apply to persons using mesh nets and lines in the waters of Port Phillip Bay, Western Port and Corner Inlet.

*By Catch*

5. (1) A person must not—

- (a) take or retain on board any vessel gummy shark (*Mustelus antarcticus*) or school (snapper) shark (*Galeorhinus galeus*) with a total combined weight of more than 50 kilograms in or adjacent to Victorian waters; or
- (b) be in possession of gummy shark (*Mustelus antarcticus*) or school (snapper) shark (*Galeorhinus galeus*) with a total combined weight of more than 50 kilograms in or adjacent to Victorian waters.

(2) A person must not land gummy shark (*Mustelus antarcticus*) or school (snapper) shark (*Galeorhinus galeus*) otherwise than in the form of a carcass.

(3) The provisions of sub-clauses (1) and (2) do not apply to a person who takes gummy shark (*Mustelus antarcticus*) or school (snapper) shark (*Galeorhinus galeus*) from the waters of Port Phillip Bay, Western Port or Corner Inlet.

(4) The provisions of sub-clause (1) (b) do not apply to a person who—

- (a) holds a Commonwealth Fishing Boat Licence issued pursuant to paragraph 9 (2) (a) of the Commonwealth Fisheries Act 1952 which is endorsed to exempt the licence holder from the prohibitions contained in

1646 G 25 1 July 1992

Commonwealth Fisheries Notice 163A;  
or

(b) holds a Commonwealth Fishing Boat Licence issued pursuant to paragraph 9 (2) (b) of the Commonwealth Fisheries Act 1952 which authorises use of the boat in the southern shark gillnet fishery; or

(c) holds a fishing permit issued pursuant to section 32 (1) of the Commonwealth Fisheries Management Act 1991.

(5) For the purpose of this clause "carcass" means the body of a shark which is not cut or mutilated in any manner whatsoever other than to remove the gut and head forward and clear of the posterior (fifth) gill slit.

*Penalty*

6. Any person who contravenes this notice is liable to a penalty of 20 penalty units. 20090

*Transport Act 1983*

**ROADS CORPORATION**

**Commercial Passenger Vehicle and Tow Truck Applications**

Notice is hereby given that the following applications will be considered by the Roads Corporation on 4 August 1992.

Notice of any objection to the granting of an application should be forwarded to reach the Section Leader, Vehicle Licensing or any District Office of the Roads Corporation not later than 29 July 1992.

It will not be necessary for interested parties to appear on the date specified, unless advised in writing by the Corporation.

Notification of the date for consideration of applications which are objected to and which require determination by the Road Transport Licensing Tribunal will be published by further notice in this Gazette.

A. W. Nicholson Pty. Ltd., Wendouree. Application to license one commercial passenger vehicle in respect of a 1987 Nissan Civilian bus with seating capacity for 22 passengers to operate a courtesy service for the carriage of employees from the applicant company's main site at 358 Dowling Street, Wendouree to various building sites within a 350 km radius of the Principal Post Office in the City of Ballarat.

*Note:* Employees will be picked up/set down at 358 Dowling Street, Wendouree.

*Victoria Government Gazette*

Balaclava Towing Pty. Ltd., Caulfield. Application to license one class 2 tow truck to operate throughout the State of Victoria from a depot situated at 512 Glen Eira Road, Caulfield for the purpose of lifting and carrying or towing damaged or disabled motor cars excluding the ability to attend the scene of a motor car accident.

Balaclava Towing Pty. Ltd., Caulfield. Application to license one class 2 tow truck to be purchased to operate throughout the State of Victoria from a depot situated at 512 Glen Eira Road, Caulfield for the purpose of lifting and carrying or towing damaged or disabled motor cars excluding the ability to attend the scene of a motor car accident.

C. and K. Gibbs, Wodonga. Application to license one commercial vehicle to be purchased in respect of a 1991 Toyota omnibus with seating capacity for 12 passengers to operate for the carriage of children attending the applicant's child care centre, 18 Bank Street, Wodonga between the centre and primary schools located in the Wodonga area.

G. G. Hargreaves, Echuca. Application for variation of the conditions of licences CH 411 and CH 414 which authorise the licensed vehicles to operate as country hire cars throughout the State of Victoria except that the passengers will be picked up/set down within a 50 km radius of the Echuca Post Office to change the radius to be picked up/set down within a 250 km radius of the Echuca Post Office.

G. D. and N. E. Lean, Maryborough. Application for variation of the conditions of licences TO 149 and TO 150 which authorise the licensed vehicles to operate various tours in Ballarat to include the ability to operate—

- (i) two additional tours as follows:
  - to places of interest within a 50 km radius of the Principal Post Office in the City of Ballarat
  - to wineries situated within a 25 km radius of the Avoca Post Office.

*Note:* Passengers will be picked up/set down from within a 20 km radius of the Principal Post Office in the City of Ballarat; and

- (ii) the existing "City Lights Tour" all year round instead of only for the duration of the Ballarat Begonia Festival.

P. G. Liston, Alfredton. Application to license one commercial passenger vehicle in respect of a 1990 Nissan 4WD station wagon with seating capacity for 6 passengers to operate a service for the carriage of passengers as follows:

- (i) to farm properties involved in sheep and wool production as follows:  
Titangia, Lismore  
Gala, Lismore  
Tarnwarcoort, Colac  
Yuulong, Scotsburn  
Lancefield Heights, Lancefield  
Coliban Park, Kyneton
- (ii) on cultural and historical tours of the Australian Wool Industry as follows:  
National Wool Museum, Geelong  
Wimmera Wool Factory, Horsham  
Victoria's Farm Shed, Tynong  
The Phillip Island Wool Centre, Phillip Island  
Macka's Family Farm, Port Campbell  
Yarra Brae Farm, Wonga Park
- (iii) Sovereign Hill, Ballarat  
Seven Creeks Run, Euroa  
Tuki Fishing and Farming Complex, Smeaton  
Victoria's Goldfields Tourist Route  
Daylesford Mineral Springs, Daylesford  
Howquadale Retreat, Mansfield

*Note:* Passengers will be picked up/set down from within a 20 km pick-up radius of the Melbourne GPO and within a 20 km pick-up radius of the Principal Post Office in the Cities of Ballarat, Geelong and Bendigo.

*Fares:* By agreement with the hirer.

*Timetable:* As and when required.

Roadways Pty. Ltd., Coburg. Application for variation of the conditions of tow truck licence numbers 041 and 791 which authorise the licensed vehicles to be managed, controlled and operated from a depot situated at 37 Williams Road, Coburg to change the depot address to 64 Kerr Street, Fitzroy.

*Note:* These licences are currently under consideration for transfer to Betta-Tow Pty. Ltd., Fitzroy.

G. D. Sandlant, Landsborough. Application for variation of the conditions of licences CO 1328 and CO 1331 which authorise the licensed vehicles to operate various route services, school services, tours and under charter conditions from within a 20 km pick-up radius of the Stawell and Halls Gap Post Offices to

include the ability to operate a service for the carriage of members of the Ararat and District Junior Football Association as follows:

- (i) On excursions as follows:

*Duration 1 day*—to Australian Football League (AFL) matches; and

*Duration 2-3 days*—to interleague and round-robin football matches played throughout the State of Victoria;

- (ii) to various football venues situated within a 100 km radius of the Ararat Post Office.

*Note:* Passengers will be picked up/set down within a 10 km radius of the Ararat Post Office.

G. Stoney, Mansfield. Application for variation of the conditions of license TO 129 which authorises various tours commencing from the licence holders depot situated two and a half kilometres from Jamieson on the Jamieson-Hayfield Road or from any given point along each defined route. Passengers may also be picked up from Mansfield Airstrip to instead—

- (i) commence tours from the licence holder's property "Minto Park", Mt Buller Road, Mansfield, Mansfield township or from any given point along each defined route. Passengers may also be picked up from Mansfield Airstrip; and

- (ii) include an additional variation to the Mt Stirling Tour as follows via Mt Stirling Summit, Clear Hills Track to Circuit Road, Bindaree, Brocks Road and Merrijig.

Tupperware Australia Pty. Ltd., Reservoir. Application to license one commercial passenger vehicle in respect of a 1987 Toyota Commuter minibus to operate a courtesy service for the carriage of the applicant company's employees between the company carpark, Brex Court, Reservoir and the main factory, 6 Radford Road, Reservoir.

*Timetable:* As and when required.

Warmambool Radio Taxis Pty. Ltd., Warmambool. Application to license one commercial passenger vehicle in respect of a 1985 Toyota bus or similar vehicle with a seating capacity for 22 passengers to operate as follows:

- (i) for the carriage of patrons of the Lady Bay Hotel, Warmambool and

1648 G 25 1 July 1992

Rafferty's Hotel, Warrnambool between the Warrnambool Post Office and the Hotels;

- (ii) for the carriage of passengers to race meetings at Warrnambool, Terang, Mortlake, Peshurst, Camperdown, Hamilton and Colac.

*Note:* Passengers will be picked up/set down from the Warrnambool Post Office.

- (iii) for the carriage of passengers to football matches throughout the State of Victoria.

*Note:* Passengers will be picked up/set down from the Warrnambool Post Office.

*Fares:* By agreement with the hirer.

*Timetable:* As and when required.

Wilson Parking Australia 1992 Pty. Ltd., East Melbourne. Application to license one commercial passenger vehicle in respect of a 1992 Toyota Coaster bus with seating capacity for 20 passengers to operate a courtesy service for the carriage of the applicant company's clients between the long term public car park situated at Melrose Drive, Tullamarine and Melbourne Airport, Tullamarine.

Dated 1 July 1992

RAY DONNELLEY  
20703 Section Leader—Vehicle Licensing

*Transport Act 1983*  
ROADS CORPORATION  
Commercial Passenger Vehicle Applications  
Amendment to Previous Notice

This notice corrects a previous notice which appeared in the *Victoria Government Gazette* No. 24 dated 24 June 1992. Closing date for objections and the consideration date specified in that notice shall remain the same.

G. Thompson, Carrum Downs. Application to license one commercial passenger vehicles in respect of a 1989 Holden Commodore sedan with seating capacity for 4 passengers to operate a service for the carriage of employees of Maurice Blackburn & Co., Solicitors, 550 Swanston Street, Melbourne to various Law Courts within a 30km radius of the Melbourne GPO.

*Note:* Employees will be picked up/set down within a 30km radius of the Melbourne GPO.  
Dated 1 July 1992

RAY DONNELLEY  
20703 Section Leader—Vehicle Licensing

*Victoria Government Gazette*

*Transport Act 1983*  
ROADS CORPORATION  
Commercial Passenger Vehicle Applications  
Amendment to Previous Notice

This notice corrects a previous notice which appeared in the *Victoria Government Gazette* No. 24 dated 24 June 1992. Closing date for objections and the consideration date specified in that notice shall remain the same.

K. A. Kermeen, Officer. Application to license two commercial passenger vehicles in respect of 1971-1974 Jaguar sedans each with seating capacity for 4 passengers to operate as country hire cars throughout the State of Victoria from Lot 1 Station Street, Officer.

*Note:* Passengers will be picked up/set down within a 100km radius of the Officer Post Office.  
Dated 1 July 1992

RAY DONNELLEY  
20703 Section Leader—Vehicle Licensing

*Transport Act 1983*  
ROAD TRANSPORT LICENSING  
TRIBUNAL  
Tow Truck Application

Notice is hereby given that the application to the following party previously gazetted and objected to will be considered by the Road Transport Licensing Tribunal on the following date:

On Wednesday, 29 July 1992 in the Public Hearing Theatre, Ground Floor, North Building, Roads Corporation, corner Lygon and Princes Streets, Carlton commencing at 9.30 a.m.

<i>Applicant</i>	<i>Previous Gazette</i>	
	<i>No.</i>	<i>Date</i>
A. Amidjovski	G.15	15.4.92

Dated 1 July 1992

A. BARDEN  
20703 Registrar

ROAD SAFETY (BREACHES OF PERMIT  
CONDITIONS) REGULATIONS 1992

In accordance with the provisions of the *Subordinate Legislation Act 1962* notice is given of the proposal to make regulations to be known as the Road Safety (Breaches of Permit Conditions) Regulations 1992.

A Regulatory Impact Statement has been prepared as required by the *Subordinate Legislation Act*.



*Victoria Government Gazette*

The prime objective of the proposed regulations is to clarify the law relating to vehicle mass and dimension permit conditions and to provide for appropriate penalties. A subsidiary objective is to create a more equitable and easily defined offence structure for vehicle mass and dimension permit breaches.

The Regulatory Impact Statement concludes that the proposed regulation provides the most cost effective means of achieving the objective.

Comments and submissions are invited from interested parties and should be forwarded to the Legislation Officer, Roads Corporation, Legal Services Department, 4th Floor, 60 Denmark Street, Kew.

Copies of the Regulatory Impact Statement may be obtained either by writing to the Legislation Officer at the above address or by phoning her on 860 2889.

Any inquiries regarding the content of the statement should be directed to John Beshara on 345 4587.

The closing date for submissions is 21 days from the date of this notice.

COLIN JORDAN  
Acting Chief Executive  
Roads Corporation

20703

*Transport Act 1983*  
ROAD TRANSPORT LICENSING  
TRIBUNAL

Commercial Passenger Vehicle Applications

Notice is hereby given that the applications to the following parties previously gazetted and objected to will be considered by the Road Transport Licensing Tribunal on the following days:

<i>Applicant</i>	<i>Previous Gazette No.</i>	<i>Date</i>
(i) On Monday, 3 August 1992 in the Public Hearing Theatre, Ground Floor, North Building, Roads Corporation, corner Lygon and Princes Streets, Carlton commencing at 9.30 a.m.		
Kettering Nominees Pty Ltd	G.12	25.3.92
E. A. Crespo	G.13	1.4.92
K. W. R. Holdings Pty Ltd	G.8	26.2.92

G 25 1 July 1992 1649

<i>Applicant</i>	<i>Previous Gazette No.</i>	<i>Date</i>
P. Toulou	G.7	19.2.92
M. Toulou	G.7	19.2.92
(ii) On Wednesday, 5 August 1992 in the Public Hearing Theatre, Ground Floor, North Building, Roads Corporation, corner Lygon and Princes Streets, Carlton commencing at 9.30 a.m.		
G. R. & M. A. Wightman	G.11	18.3.92
J. Karanikolaou	G.14	8.4.92
P. Montalto	G.14	8.4.92
M. Clerici	G.14	8.4.92
C. & B. Loukas Nominees Pty Ltd	G.14	8.4.92

Dated 1 July 1992

A. BARDEN  
Registrar

20703

BENEFICIARY ACCOUNT INTEREST  
RATE CHANGE

Notice is hereby given in accordance with sections 81 (4) and 81 (5) of the *State Superannuation Act 1988* and Statutory Rule Number 282 clause 8 (2).

The Board has resolved that the rate of interest applicable to all beneficiary accounts will alter from 10.3% to 8.1% effective from 1 August 1992.

The new rate of 8.1% will apply until further notice.

MICHAEL GERAGHTY  
Public Officer

For and on behalf of the Trustees  
20780 State Superannuation Board of Victoria

NOTICE OF AUTHORISATION OF A  
TRUSTEE COMPANY UNDER SECTION 7  
OF THE TRUSTEE COMPANIES ACT 1984

I hereby authorise IOOF Australia Trustees Limited A.C.N. 007 870 644 to be a trustee company pursuant to section 7 of the *Trustee Companies Act 1984*.

Dated 29 June 1992

JIM KENNAN

20430 Deputy Premier and Attorney-General

1650 G 25 · 1 July 1992

STATE TENDER BOARD  
CONTRACTS ACCEPTED  
Amendments

Schedule Number	Item Number	New Rate	Effective Date
\$			
<i>Motor Vehicles (Passenger)</i>			
1/58	7	15 864.00	19.6.92
	8	17 036.00	
Options available—			
	Airconditioning	1 009.00	
	15-19,	707.00 *	
	21, 22	707.00 *	
* Options available—			
	Anti lock brakes		
	15	16 354.00 +	1.7.92
	16	16 761.00 +	
+ Options available—			
	Airconditioning	1 110.00	
	Country pack	196.00	
	Limited slip diff	262.00	
	Metallic paint	118.00	
	Police pack	359.00	
	Modified gate	14.00	
	Long range fuel tank	87.00	
	Sports suspension	150.00	
	17	17 616.00 +	
	18	18 022.00 +	
+ Options available—			
	Airconditioning	1 110.00	
	Limited slip diff	262.00	
	Metallic paint	118.00	
	Country pack	196.00	
	Police pack	359.00	
	Sports suspension	150.00	
	Long range fuel tank	87.00	
	Limited slip diff	262.00	
	Country pack suspension	196.00	
	20	24 642.00 +	
+ Options available—			
	Sports suspension	150.00	
	Limited slip diff	262.00	
	Long range fuel tank	87.00	
	21	16 264.00 +	
	22	16 671.00 +	
+ Options available—			
	Airconditioning	1 110.00	
	Police pack	359.00	
	V8 engine	1 398.00	
	Limited slip diff	262.00	
	Long range fuel tank	87.00	
	Modified auto gate	14.00	
	Sports suspension	150.00	
	Metallic paint	118.00	
	Independent rear susp.	767.00	
	Delete radio	139.00	
(Credit)			

Victoria Government Gazette

Schedule Number	Item Number	New Rate	Effective Date
\$			
<i>Motor Vehicles (Light Commercial)</i>			
1/59	3.1	11 150.00 *	19.6.92
	6.1	23 014.00 *	
	8.1	15 884.00 *	
	10.1	12 731.00 *	
	13.1	9 694.00 *	
	14.1	10 655.00 *	
	18.1	22 854.00 *	
	21.1	22 317.00 *	
	22.1	23 913.00 *	
	25.1	10 221.00 #	
	26.1	11 460.00 #	
	27.1	12 061.00 #	
	28.1	11 679.00 #	
	29.1	12 757.00 #	
* Mandatory options—			
	Eye level stop light	62.00	
	Mudflaps	62.00	
	Locking petrol cap/flap	62.00	
# Mandatory options—			
	Eye level stop light	52.00	
	Mudflaps	52.00	
	Locking petrol cap/flap	52.00	
N. L. JORDAN			
20790	Secretary to the Tender Board		

SURPLUS GOVERNMENT PROPERTIES

The following properties have been declared surplus and may be offered for sale by public auction or tender by the Ministry of Finance:

MOF Ref.	Address
16375	Firebrace Road, Heyfield
16377	Firebrace Road, Heyfield
17291	McMahon Road, Kinglake
16313	Princes Street, Traralgon
16055U	R/L 16 Railway Avenue, Werribee
16055Y	R/L 15 Railway Avenue, Werribee
16898	76 McBride Street, Wonthaggi
65575	Midland Highway, Creswick North
65576	Midland Highway, Creswick North
65577	Fir Street, Golden Square
65568	Gregory Street, Pyramid Hill
65569	Gregory Street, Pyramid Hill

Any sales will be advertised in the property section of local newspapers.

Rezoning will be undertaken where necessary.

For further information phone Ministry of Finance (03) 651 4025 20360

Department of Manufacturing and Industry  
Development

APPLICATION FOR MINING LICENCE  
GRANTED

- No. 4163; Cathgold P/L; 167.2 ha, Parish of Avoca.  
No. 4284; R. J. Emmins and N. J. R. Ayre; 192 ha, Parishes of Trentham and Blackwood.  
No. 4303; I. B. Williams and R. G. Wilson; 0.75 ha, Parish of Bungywarra.  
No. 4541; K. & J. Baker Cartage P/L; 47.56 ha, Parish of Drung Drung.

APPLICATION FOR MINING LICENCE  
REFUSED

- No. 4581; Fortunee Gold P/L; 49.6 ha, Parish of Craigie.

MINING LEASE CANCELLED

- No. 645; H. C. Cann; 9.6 ha, Parish of Tylden.  
No. 1009; H. C. Cann; 8.94 ha, Parish of Tylden.

APPLICATION FOR EXPLORATION  
LICENCE GRANTED

- No. 3115; Rimlex Mining P/L; 14 grats; 12 km<sup>2</sup>, Bet Bet.  
No. 3189; Bruce Resources NL; 47 grats; Tallangatta.

APPLICATION FOR EXPLORATION  
LICENCE WITHDRAWN

- No. 3243; New Holland Mining NL; 3 grats; Strathfieldsaye.  
No. 3282; Terrock P/L; 200 grats; Kara Kara.

EXPLORATION LICENCE RENEWED

- No. 3002-1; Perservance Mining P/L; 36 grats; Goulburn.  
No. 3020-1; A. R. Fraser; 15 grats; Ballan.  
No. 3088-4; Ballarat Goldfields NL; 9 grats; Ballarat.  
No. 3241-2; Perservance Exploration P/L; 37 grats; Huntly.  
No. 3248-3; Western Mining Corporation Ltd; 56 grats; Stawell.  
No. 3255-1; Ashton Mining Ltd; 65 grats; Stawell and Avoca.  
No. 3258-2; CRA Exploration P/L; 432 grats; Kerang.  
No. 3259-2; CRA Exploration P/L; 94 grats; Donald.  
No. 3260-2; CRA Exploration P/L; 490 grats; Donald.

- No. 3262-1; Noble Resources NL; 37 grats; Talbot and Clunes.

EXPLORATION LICENCE GRANTED/  
RENEWED AND AMALGAMATED

- Nos 3019-1 and 3052-2; 38 grats; Ararat.  
Upon amalgamation into EL 3019-1, EL 3052-2 was cancelled.

EXPLORATION LICENCE  
AMALGAMATED

- Nos 774/10, 787/10, 789-10, 790-10, 791-10, 793-10, 999-10, 1255-8, 1256-8, 1257-8, 1258-8, 1260-8, 1298-8, 1315-7, 1344-7, 1362-7, 1364-7, 1917-4; Wimmera Industrial Minerals P/L; 3656 km<sup>2</sup>, Dunmunkle.

- Upon amalgamation, EL Nos 787-10, 789-10, 790-10, 791-10, 793-10, 999-10, 1255-8, 1256-8, 1257-8, 1258-8, 1260-8, 1298-8, 1315-7, 1344-7, 1362-7, 1364-7 and 1917-4 were cancelled.

- EXPLORATION LICENCE SURRENDERED  
No. 3010; CRA Exploration P/L; 102 grats; Omeo.

The above relinquished area will become available again for Exploration Licence on 17 September 1992.

MINER'S RIGHT CLAIM SURRENDERED

- No. 2546; Ballarat Industrial Minerals P/L; 1 ha, Parish of Buninyong.  
No. 3104; G. W. Mee and H. J. Helms; 1 ha, Parish of Narracan.  
No. 3265; T. W. Widows; 4.1 ha, Parish of Tullaroop.  
No. 3343; A. J. Waugh; 0.6 ha, Parish of Kingower.  
No. 3398; D. E. Neller; 2.25 ha, Parish of Moliagul.  
No. 3526; M. C. Scott; 1.75 ha, Parish of Moliagul.

MINER'S RIGHT CLAIM EXPIRED

- No. 1407; Korong Gold Mining & Drilling Co. P/L; 1.07 ha, Parish of Wedderburne.  
No. 1933; S. Habenschuss and G. Rafferty; 4.9 ha, Parish of Koombearar.  
No. 2075; F. J. Foo and A. Strange; 0.4 ha, Parish of Ballarat.

1652 G 25 1 July 1992

EXTRACTIVE INDUSTRIES LICENCE;  
RENEWAL APPLICATION CANCELLED,  
LICENCE EXPIRED

No. 729-2; W. J. and M. H. Stevenson; 56.7 ha,  
Parish of Sherwood.

No. 1047; T. H. Gribben; 5.186 ha, Parish of  
Waaia.

20400 DAVID WHITE  
Minister for Manufacturing  
and Industry Development

*Land Acquisition and Compensation Act 1986*  
*Transport Act 1983*

NOTICE OF ACQUISITION

Compulsory Acquisition of Interest in Land

The Roads Corporation declares that by this  
notice it acquires the following interest in the  
land described hereunder:

*Owner's Name:* Maria Diana  
Anagnostopoulos.

*Description of Interest in Land:* Lots 33 and  
34 on Plan of Subdivision No. 12996, Parish of  
Cut Paw Paw.

*Area:* 1161 square metres.

*Title Details:* Certificate of Title Volume  
9531 Folio 288.

*Survey Plan No.:* 18475.

The survey plan referred to in this notice may  
be viewed at Property Services Department, Vic  
Roads, 2nd Floor, 3 Prospect Hill Road,  
Camberwell.

Published with the authority of the Roads  
Corporation and the Minister for Transport.

20703 DEREK TREWARNE  
Manager, Property Operations  
Roads Corporation

*Land Acquisition and Compensation Act 1986*  
NOTICE OF ACQUISITION

Compulsory Acquisition of an Interest in Land

Gas and Fuel Corporation of Victoria declares  
that by this notice, it acquires an interest in part  
of the land being part of Crown Allotment 21,  
Section C and being Lot 3 on plan of subdivision  
300710, Parish of Bootahpool described in  
Certificate of Title Volume 9998 Folio 917.

The interest acquired is an easement 20  
metres in width, having an area of 1.820  
hectares. Plans may be inspected at the Property  
Department, 151 Flinders Street, Melbourne.

*Victoria Government Gazette*

Published with the authority of Gas and Fuel  
Corporation of Victoria.

20320 W. L. FITZHERBERT  
Secretary

*Land Acquisition and Compensation Act 1986*  
NOTICE OF ACQUISITION

Compulsory Acquisition of an Interest in Land  
Gas and Fuel Corporation of Victoria declares  
that by this notice, it acquires an interest in part  
of the land being part of Crown Allotment 127B,  
Parish of St. Helens described in Certificate of  
Title Volume 9812 Folio 759 and Volume 7210  
Folio 988.

The interest acquired is an easement 20  
metres in width, having an area of 1.611  
hectares. Plans may be inspected at the Property  
Department, 151 Flinders Street, Melbourne.

Published with the authority of Gas and Fuel  
Corporation of Victoria.

20320 W. L. FITZHERBERT  
Secretary

NOTICE OF ACQUISITION

Compulsory Acquisition of Interest in Land

Director of Housing declares that by this  
notice it acquires the following interest in the  
land described in Memorial of Conveyance  
Number 892 of Book 642.

*Interest Acquired:* That of an owner in fee  
simple.

Published with the Authority of Director of  
Housing.

Dated 23 June 1992

20390 T. SWEENEY  
Group Manager  
Property and Improvement

NOTICE OF ACQUISITION

Compulsory Acquisition of Interest in Land

Director of Housing declares that by this  
notice it acquires the following interest in the  
land described in Memorial of Conveyance  
Number 97 of Book 643.

*Interest Acquired:* That of an owner in fee  
simple.

Published with the Authority of Director of  
Housing.

Dated 23 June 1992

20390 T. SWEENEY  
Group Manager  
Property and Improvement

Victoria Government Gazette

NOTICE OF ACQUISITION

Compulsory Acquisition of Interest in Land

Director of Housing declares that by this notice it acquires the following interest in the land described in Memorial of Conveyance Number 925 of Book 634.

*Interest Acquired:* That of an owner in fee simple.

Published with the Authority of Director of Housing.

Dated 23 June 1992

T. SWEENEY  
Group Manager  
Property and Improvement  
20390

NOTICE OF ACQUISITION

Compulsory Acquisition of Interest in Land

Director of Housing declares that by this notice it acquires the following interest in the land described as the whole of the land contained in Certificate of Title Volume 3646 Folio 035.

*Interest Acquired:* That of an owner in fee simple.

Published with the Authority of Director of Housing.

Dated 23 June 1992

T. SWEENEY  
Group Manager  
Property and Improvement  
20390

NOTICE OF ACQUISITION

Compulsory Acquisition of Interest in Land

Director of Housing declares that by this notice it acquires the following interest in the land described in Memorial of Conveyance Number 375 of Book 369.

*Interest Acquired:* That of an owner in fee simple.

Published with the Authority of Director of Housing.

Dated 23 June 1992

T. SWEENEY  
Group Manager  
Property and Improvement  
20390

NOTICE OF ACQUISITION

Compulsory Acquisition of Interest in Land

Director of Housing declares that by this notice it acquires the following interest in the land described in Memorial of Conveyance Number 209 of Book 551.

G 25 1 July 1992 1653

*Interest Acquired:* That of an owner in fee simple.

Published with the Authority of Director of Housing.

Dated 23 June 1992

T. SWEENEY  
Group Manager  
Property and Improvement  
20390

SHIRE OF WARANGA

Road Deviation

Pursuant to the provisions of sections 522 and 526 of the *Local Government (Miscellaneous) Act 1958* the Council of the Shire of Waranga hereby directs that the land in the Parish of Wanalta indicated by hatching on the diagram hereunder (or annexed hereto), which has been purchased taken or acquired by it, shall be a public highway on and from the date of publication of this order in the *Government Gazette* and declares that such land shall be a public highway in lieu of the land indicated by cross-hatching on the said diagram.

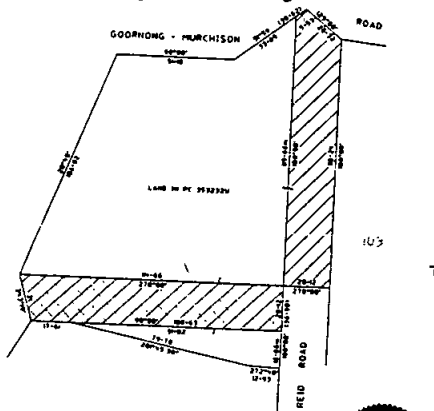

THE ROAD TO BE CLOSED IS SHOWN THUS [diagonal hatching symbol]  
THE ROAD TO BE OPENED IS SHOWN THUS [cross-hatching symbol]

The Common Seal of the President Councillors and Ratepayers of the Shire of Waranga was hereto affixed in the presence of—

B. A. BRISBANE, President  
R. S. RISSTROM, Councillor  
R. F. B. KELLY, Secretary

Dated: 18 February 1992

Confirmed by the Governor in Council, 30 June 1992—DAMIEN O'SHEA, Acting Clerk of the Executive Council 20460

1654 G 25 1 July 1992

*Local Government Act 1989*  
DATES FOR PAYMENT OF RATES AND  
CHARGES

I, Caroline Hogg, Minister for Ethnic, Municipal and Community Affairs, acting under section 167 (2) of the *Local Government Act 1989* fix—

- (a) 10 April as the date on which the whole of a rate or charge (other than a special rate or charge) is due; and
- (b) 31 December, 28 February, 30 May and 31 August as the dates on which payments by 4 instalments of the rate or charge are due.

CAROLINE HOGG  
Minister for Ethnic, Municipal and  
Community Affairs

20460

*Local Government Act 1958*  
SHIRE OF BAIRNSDALE  
Vesting of Land in Council

I, Caroline Hogg, Minister for Ethnic, Municipal and Community Affairs, being satisfied that the land hereunder has been vacant for not less than three years and that default has been made in the payment of rates on the land to the Shire of Bairnsdale for not less than five years and in pursuance of the powers vested in me by section 385B of the *Local Government Act 1958* do, by this Order, vest in the Council of the Shire of Bairnsdale the land described as allotments;

	(Land Described in Certificate of Title—)
54 Crown Ridge Avenue	Volume 8579 Folio 754
173 Village Fair Drive	Volume 8579 Folio 873
678 Lake Inlet Avenue	Volume 8842 Folio 281
710 Lake Harbour Avenue	Volume 8842 Folio 313
819 Butlers Point Drive	Volume 8794 Folio 932

Dated 23 June 1992

CAROLINE HOGG  
Minister for Ethnic, Municipal and  
Community Affairs

20460

*Victoria Government Gazette*

INDUSTRIAL RELATIONS ACT 1979

Notice is hereby given that the Police Association has lodged an application for the appointment of a Conciliation and Arbitration Board for the Police Force.

Notice is also given that this matter is listed for hearing before the Industrial Relations Commission of Victoria in Full Session at 2.15 p.m. on Tuesday, 7 July 1992 at Nauru House, 80 Collins Street, Melbourne.

J. TSOUTSOULIS  
Deputy Registrar  
Industrial Relations Commission  
of Victoria

21292

*Industrial Relations Act 1979*

NOTICE OF APPLICATION FOR  
RECOGNITION AS AN ASSOCIATION

Notice is hereby given that the National Association of Nursing Homes and Private Hospitals Incorporated has filed an application to be recognised as an association under the *Industrial Relations Act 1979* with respect to the trades for which the Health and Allied Services, Health Professional Services and Registered Nurses Conciliation and Arbitration Boards have been appointed.

Pursuant to regulation 33 (5) of the Industrial Relations Regulations any recognised association or person interested may on or before 31 July 1992 file in the Registry (Level 20, Nauru House, 80 Collins Street, Melbourne) an objection to the application.

The objection shall be in, or to the effect of Form 9 prescribed by the Regulations.

J. TSOUTSOULIS  
Deputy Registrar  
Industrial Relations Commission  
of Victoria

21292

*Finance Brokers Act 1969*

MINISTRY OF CONSUMER AFFAIRS

The Finance Brokers Regulations 1992 were approved by the Governor in Council on 30 June 1992.

The regulations prescribe forms, procedures, licence fees, maximum valuation fees, commissions and classes of persons to whom the *Finance Brokers Act 1969* does not apply. The regulations come into effect immediately and replace earlier regulations.

20110

*Victoria Government Gazette*

*Police Regulation Act 1958—Section 122*  
SALE OF UNCLAIMED PROPERTY

An owner is required for a Datsun station wagon Registered No. (W.A.) WN 10279

This vehicle came into the possession of Police on 5 July 1991 and if not claimed it will be sold at public auction at 10 a.m. on Tuesday, 28 July 1992 at the Werribee Police Station, Prince's Highway, Werribee.

20620 K. GLARE  
Chief Commissioner

*Police Regulation Act 1958—Section 122*  
SALE OF UNCLAIMED PROPERTY

An owner is required for an unregistered 1965 model green Holden HR station wagon with engine No. 161R163909.

This vehicle came into the possession of Police on 10 January 1992 and if not claimed it will be sold at public auction at 10 a.m. on Wednesday, 22 July 1992 at the Thomastown Police Station, 8 Main Street, Thomastown.

20620 K. GLARE  
Chief Commissioner

*Police Regulation Act 1958—Section 122*  
SALE OF UNCLAIMED PROPERTY

An owner is required for an unregistered orange 1973 model "Montessa" King Scorpion 250cc motor cycle with engine No. 44M0504.

This vehicle came into the possession of Police on 29 December 1991 and if not claimed it will be sold at public auction at 10 a.m. on Tuesday, 21 July 1992 at the Croydon Police Station, 17 Kent Street, Croydon.

20620 K. GLARE  
Chief Commissioner

COMMONWEALTH OF AUSTRALIA  
Delegation under Section 8H of the *Petroleum*  
(*Submerged Lands*) Act 1967 (The Act)

We, Alan Gordon Griffiths, the Minister of State for Resources for the Commonwealth of Australia (the Commonwealth Minister) and David Ronald White, the Minister for Manufacturing and Industry Development for the State of Victoria (the State Minister), the Joint Authority under the Act in respect of the adjacent area in respect of Victoria, under section 8H of the Act, hereby delegate to—

G 25 1 July 1992 1655

- (a) the person who, from time to time, holds the office of Assistant Secretary, Exploration and Development Branch, Petroleum Division, Department of Primary Industries and Energy of the Commonwealth of Australia, as the person representing the Commonwealth Minister; and
- (b) the person who, from time to time, holds, occupies, or performs the duties of, the office of Director, Energy Division, Department of Manufacturing and Industry Development of the State of Victoria, as the person representing the State Minister—

together the powers of the Joint Authority under the Act specified in the Schedule.

Schedule

1. *Petroleum (Submerged Lands) (Royalty) Act 1967—sub-section 10A (1)*
2. *Petroleum (Submerged Lands) (Registration Fees) Act 1967—sub-sections 4 (4), 4 (5), 4 (6A), 4 (6B)*

Dated 1 July 1992

ALAN GRIFFITHS  
Minister of State for Resources

20400 DAVID RONALD WHITE  
Minister of State for Manufacturing and  
Industry Development

*Conservation, Forests and Lands Act 1987*  
NOTICE OF MAKING LAND  
MANAGEMENT CO-OPERATIVE  
AGREEMENT

Notice is given under section 80 of the *Conservation, Forests and Lands Act 1987* that a Land Management Co-operative Agreement has been made between the Director-General of Conservation and Environment and Mount Bellevue Investments Pty Ltd for plantation sharefarming on Allotment 91A, Parish of Myrree, County of Delatite.

The agreement or a copy of the agreement can be inspected at offices of the Department of Conservation and Environment at the following locations: Head Office, Executive Services, 8th Floor, 240 Victoria Parade, East Melbourne and at Northeast Region, 1 McKoy Street, Wodonga.

20090 A. G. THOMPSON  
Director-General

1656 G 25 1 July 1992

*Education Act 1958*

**NOTICE OF THE MAKING OF ORDERS  
UNDER SECTION 13 (4) OF THE ACT**

Pursuant to section 13 of the *Education Act 1958* I hereby give notice that Orders of the Governor in Council were made on 23 June 1992 under sub-section (4) of the said Act amending certain provisions of the constitution of the school councils listed below—

4715 Blackburn North Primary School  
4878 Middlefield Primary School Council

NEIL POPE

20160 Minister for School Education

*Education Act 1958*

**NOTICE OF THE MAKING OF ORDERS  
UNDER SECTION 13 (4) OF THE ACT**

Pursuant to section 13 of the *Education Act 1958* I hereby give notice that Orders of the Governor in Council were made on 23 June 1992 under sub-section (4) of the said Act amending certain provisions of the constitution of the school councils listed below—

8496 Eumemmerring Secondary College  
Council  
7133 Endeavour Hills Secondary College  
Council

NEIL POPE

20160 Minister for School Education

*Education Act 1958*

**NOTICE OF THE MAKING OF ORDERS  
UNDER SECTIONS 13 (1), (4) AND (5) OF  
THE ACT**

Under section 13 of the *Education Act 1958*, I hereby give notice that Orders of the Governor in Council were made on 23 June 1992 under sub-section (1) constituting a council for—

8802 Swan Hill Secondary College  
under sub-section (4) dissolving the school  
council for

7360 Swan Hill Technical School and the  
school council for  
8365 Swan Hill High School  
and under sub-section (5) directing the disposal  
of any assets of the council for the

7360 Swan Hill Technical School and the  
school council for  
8365 Swan Hill High School.

NEIL POPE

20160 Minister for School Education

*Victoria Government Gazette*

*Education Act 1958*

**NOTICE OF THE MAKING OF ORDERS  
UNDER SECTION 13 (4) OF THE ACT**

Pursuant to section 13 of the *Education Act 1958*, I hereby give notice that Orders of the Governor in Council were made on 23 June 1992 under sub-section (4) of the said Act amending certain provisions of the constitutions of the school councils listed below—

5368 Barwon Valley School Council  
7630 Tormore Secondary College Council

NEIL POPE

20160 Minister for School Education

*Co-operation Act 1981*

MOUNT BULLER YOUTH HOSTEL  
CO-OPERATIVE LIMITED  
MURTOA H.S. & DISTRICT  
CO-OPERATIVE LIMITED  
ROSEWALL COMMUNITY  
CO-OPERATIVE LIMITED  
THE LAKES GOLF CO-OPERATIVE LTD

Notice of Dissolution of Societies

Notice is hereby given that I have this day registered the dissolution of the abovenamed societies and cancelled their registration under the abovenamed Act.

Dated at Melbourne 16 June 1992

D. F. HENRY

Deputy Registrar of  
Co-operative Societies

20430

*Co-operation Act 1981*

CRYSTAL CO-OPERATIVE SOCIETY  
LIMITED  
GISBORNE PRIMARY SCHOOL  
CO-OPERATIVE LTD  
QUALITO SEED CO-OPERATIVE LTD  
STATISTICAL CONSULTANCY  
CO-OPERATIVE LIMITED  
YABAMAC BOY SCOUT CO-OPERATIVE  
LTD

Notice is hereby given in pursuance of section 192 (8) of the *Co-operation Act 1981* and section 572 (2) of the *Corporations Act 1989* that, at the expiration of three months from the date hereof, the names of the aforementioned societies will, unless cause is shown to the contrary, be struck off the register and the societies will be dissolved.

Dated at Melbourne 15 June 1992

D. F. HENRY

Deputy Registrar of  
Co-operative Societies

20430



Victoria Government Gazette

DEPARTMENT OF FOOD AND  
AGRICULTURE

Bees Regulations 1992

In accordance with the provisions of the *Subordinate Legislation Act 1962* notice is given of the proposal to make regulations to be known as the Bees Regulations 1992.

A Regulatory Impact Statement has been prepared as required by the Subordinate Legislation Act.

The objective of these regulations is to implement the *Bees Act 1971* which seeks to limit the spread of disease amongst bees by regulating the keeping of bees and by providing compensation to individuals who would otherwise suffer unreasonable burdens as a result of the disease limitation policy.

The Regulatory Impact Statement concludes that the proposed regulations are the most effective means of achieving the stated objective.

Copies of the Regulatory Impact Statement and the proposed regulations may be obtained from Mr Kevin Pagon, Legal Branch, Department of Food and Agriculture, "The Mill", 165 Hargreaves Street, Bendigo 3550. Telephone (054) 304 476 or Fax (054) 304 499.

Comments and submissions are invited from interested parties.

Written submissions should be sent to the above address no later than 21 days from the publication of this notice.

20200 **MICHAEL BLAMEY**  
Director General

*Water Act 1989*

NOTICE OF DIRECTION GIVEN UNDER  
SECTION 307

I, David Downie, Director-General of Water Resources on behalf of the Minister give notice under section 307 (3) of the *Water Act 1989* that on 23 June 1992, John Harrowfield, Acting Minister for Water Resources gave a direction under section 307 of the *Water Act 1989* and all other enabling powers to the Heathcote Water Board.

SUMMARY OF CONTENTS OF THE  
DIRECTION GIVEN ON 23 JUNE 1992

The Heathcote Water Board is directed to not effect any significant changes to its assets and operations without the prior consent in writing

G 25 1 July 1992 1657

of the Director-General of the Department of  
Water Resources.

Dated: 29 June 1992

21210 **DAVID DOWNIE**  
Director-General  
Department of Water Resources

NOTICE OF AVAILABILITY OF  
STATUTORY RULES  
Accident Compensation (Amendment)  
Regulations 1992

Notice is given that the above Regulations were made by the Governor in Council on 30 June 1992. The Regulations come into operation on 1 July 1992.

In accordance with the provisions of the *Subordinate Legislation Act 1962*, copies of the above Regulations are available for inspection by any member of the public without charge during normal office hours at the Department of Labour, Level 23, Nauru House, 80 Collins Street, Melbourne.

Dated: 30 June 1992

20290 **JOHN HARROWFIELD**  
Minister for Finance  
as Minister assisting the  
Minister for Labour

NOTICE OF AVAILABILITY OF  
STATUTORY RULES  
Workers Compensation (Interest Rates)  
Regulations 1992

Notice is given that the above Regulations were made by the Governor in Council on 30 June 1992. The Regulations come into operation on 1 July 1992.

In accordance with the provisions of the *Subordinate Legislation Act 1962*, copies of the above Regulations are available for inspection by any member of the public without charge during normal office hours at the Department of Labour, Level 23, Nauru House, 80 Collins Street, Melbourne.

Dated 30 June 1992

20290 **JOHN HARROWFIELD**  
Minister for Finance  
as Minister assisting the  
Minister for Labour

---

1658 G 25 1 July 1992

VETERINARY SURGEONS ACT 1958  
(As amended)

Victoria Government Gazette

The Veterinary Board of Victoria (the Board) conducted an inquiry on 5 February and 3 June 1992 into the conduct of Dr. Maurice Newport, a registered veterinary surgeon, of 22 Walbunary Avenue, North Balwyn in the State of Victoria to ascertain whether he was using the name "Village Veterinary Clinic" in contravention of Regulation 29 (1) (b) of the Veterinary Surgeons Regulations 1988.

The Board found the charge proven. Dr. Newport was reprimanded and ordered to pay \$455 towards the cost of and incidental to the inquiry. He was granted three months in which to pay the costs.

M. B. WILSON  
Registrar

20880

---

**APPOINTMENTS**

**CHILDREN'S AND YOUNG PERSONS  
ACT 1989**

I, Mark Diamond (Regional Director) of Gippsland Region of Community Services Victoria, under section 34 (4) of the *Children's and Young Persons Act 1989* appoint the undermentioned persons as Honorary Probation Officers in the State of Victoria.

Jenny Anders, RMB 4259, Morwell.  
Justine Anderson, 15 Washington Street, Traralgon.

Donna Bertacchini, 2/6 McMillan Street, Traralgon.

Diane Burns, Jeeralang North Road, Jeeralang North.

Sam Calabro, 6 Barry Street, Morwell.

Graham Jamieson, 25 Peace Avenue, Warragul.

Nicole Morgan, 1/19 Contingent Street, Trafalgar.

Mary Nativo, Ferndale, RMB 2825, Warragul.

Ann Pulbrook, 5 McKay Court, Churchill.

Tanya Rowswell, 54 Dell Circuit, Morwell.

Laurie Trevena, 196 Liddiard Road, Traralgon.

Noris Trevena, 196 Liddiard Road, Traralgon.

Rodney Verrill, 15 Washington Street, Traralgon.

Kim West, 18 Haywood Street, Morwell.

Dated 19 June 1992

M. DIAMOND  
Regional Director

20080

Rob Woszezioko, 16 Forest Street, Drouin.

Enid Cassells, 1 Ramsden Street, Drouin.

Ian Whannell, 18 Willow Street, Churchill.

Sue Masalski, 92 Bridle Road, Morwell.

Dated 22 June 1992

M. DIAMOND  
Regional Director

20080

**CHILDREN'S AND YOUNG PERSONS  
ACT 1989**

I, Mark Diamond (Regional Director) of Gippsland Region of Community Services Victoria, under section 34 (4) of the *Children's and Young Persons Act 1989* revoke the appointment of the undermentioned persons as Honorary Probation Officers in the State of Victoria.

Leanne McGillivray, 59 Vincent Road, Morwell.

Anne Slocombe, 17 Austin Avenue, Moe.

Doug Slocombe, 17 Austin Avenue, Moe.

Sandra Porch, 3 Pine Grove, RSD 5182, Warragul.

## ORDERS IN COUNCIL

*Local Government Act 1958*  
**CONFIRMATION OF SEPARATE RATE**  
 Shire of Flinders

The Governor in Council acting under section 287 of the *Local Government Act 1958* confirms a separate rate made by the Council of the Shire of Flinders on 1 April 1992 for the purpose of constructing Caldwell Road, Dromana.

Dated 10 June 1992

Responsible Minister:

CAROLINE HOGG

Minister for Ethnic, Municipal  
 and Community Affairs

DAMIEN O'SHEA

20460 Acting Clerk of the Executive Council

*Drainage Areas Act 1958*  
**NOTICE OF APPROVAL OF SPECIAL**  
**MAINTENANCE CHARGE**

Notice is given that the Governor in Council acting under section 36 of the *Drainage Areas Act 1958* has approved a special maintenance charge and estimate for the Lake Wangoom Drainage Area for the year ending 30 September 1992 made by the Council of the Shire of Warrambool.

Dated 10 June 1992

Responsible Minister:

CAROLINE HOGG

Minister for Ethnic, Municipal  
 and Community Affairs

DAMIEN O'SHEA

20460 Acting Clerk of the Executive Council

*Country Fire Authority Act 1958*  
**FIXING THE RATE OF INTEREST FOR THE**  
**PURPOSES OF SECTION 81 (c) OF THE**  
**COUNTRY FIRE AUTHORITY ACT 1958**

The Governor in Council, under section 81 (c) of the *Country Fire Authority Act 1958*, fixes the rate of interest for the purposes of section 81 (c) at 13 per cent per annum to apply to amounts which first become due and payable under section 81 (b) on or after 1 July 1992.

Dated 23 June 1992

Responsible Minister:

M. SANDON

Minister for Police and Emergency Services

DAMIEN O'SHEA

20620 Acting Clerk of the Executive Council

*Country Fire Authority Act 1958*  
**FIXING THE RATE OF INTEREST FOR THE**  
**PURPOSES OF SECTION 80 (1) (d) OF THE**  
**COUNTRY FIRE AUTHORITY ACT 1958**

The Governor in Council, under section 80 (1) (d) of the *Country Fire Authority Act 1958*, fixes the rate of interest for the purposes of section 80 (1) (d) at 13 per cent per annum to apply to amounts which first become due and payable on or after 1 July 1992.

Dated 23 June 1992

Responsible Minister:

M. SANDON

Minister for Police and Emergency Services

DAMIEN O'SHEA

20620 Acting Clerk of the Executive Council

*Country Fire Authority Act 1958*  
**FIXING THE RATE OF INTEREST FOR THE**  
**PURPOSES OF SECTION 78 (4) (b) and (5)**  
**(e) OF THE COUNTRY FIRE AUTHORITY**  
**ACT 1958**

The Governor in Council, under section 78 (4) (b) and (5) (e) of the *Country Fire Authority Act 1958*, fixes the rate of interest for the purposes of section 78 (4) (b) and (5) (e) at 13 per cent per annum to apply to amounts which first become due and payable under section 78 (4) (a) and section 78 (5) (d), respectively, on or after 1 July 1992.

Dated 23 June 1992

Responsible Minister:

M. SANDON

Minister for Police and Emergency Services

DAMIEN O'SHEA

20620 Acting Clerk of the Executive Council

*Country Fire Authority Act 1958*  
**FIXING THE RATE OF INTEREST FOR THE**  
**PURPOSES OF SECTION 41c (2) (a) OF THE**  
**COUNTRY FIRE AUTHORITY ACT 1958**

The Governor in Council, under section 41c (2) (a) of the *Country Fire Authority Act 1958*, fixes the rate of interest for the purposes of section 41c (2) (a) at 13 per cent per annum to apply to amounts which first become due and payable on or after 1 July 1992.

Dated 23 June 1992

Responsible Minister:

M. SANDON

Minister for Police and Emergency Services

DAMIEN O'SHEA

20620 Acting Clerk of the Executive Council

*Public Service Act 1974*

**AUTHORITY TO REDEPLOY STAFF**

On the recommendation of the Premier, the Governor in Council authorises, under section 64B of the *Public Service Act 1974*, the employment of employees of Victorian Prison Industries Commission and Victorian Accident Rehabilitation Council in administrative units and associated administrative units listed in Schedules Two, Three and Three A to the *Public Service Act 1974* and in public statutory authorities defined under section 3 of the *Public Service Act 1974*, if such employees and persons become redundant within twelve months because of the proposed introduction of new technology, or changed practices or organisation or otherwise.

Dated 23 June 1992

Responsible Minister:

JOAN E. KIRNER

Premier

DAMIEN O'SHEA

20660 Acting Clerk of the Executive Council

*Metropolitan Fire Brigades Act 1958*  
**FIXING THE RATE OF INTEREST FOR THE PURPOSES OF SECTION 45 (c) OF THE METROPOLITAN FIRE BRIGADES ACT 1958**

The Governor in Council, under section 45 (c) of the *Metropolitan Fire Brigades Act 1958*, fixes the rate of interest for the purposes of section 45 (c) at 13 per cent per annum to apply to amounts which first become due and payable under section 45 (b) on or after 1 July 1992.

Dated 23 June 1992

Responsible Minister:

M. SANDON

Minister for Police and Emergency Services

DAMIEN O'SHEA

20620 Acting Clerk of the Executive Council

*Metropolitan Fire Brigades Act 1958*  
**FIXING THE RATE OF INTEREST FOR THE PURPOSES OF SECTION 43 (1) (e) OF THE METROPOLITAN FIRE BRIGADES ACT 1958**

The Governor in Council, under section 43 (1) (e) of the *Metropolitan Fire Brigades Act 1958*, fixes the rate of interest for the purposes of section 43 (1) (e) at 13 per cent per annum to apply to amounts which first become due and payable on or after 1 July 1992.

Dated 23 June 1992

Responsible Minister:

M. SANDON

Minister for Police and Emergency Services

DAMIEN O'SHEA

20620 Acting Clerk of the Executive Council

*Metropolitan Fire Brigades Act 1958*  
**FIXING THE RATE OF INTEREST FOR THE PURPOSES OF SECTION 41 (4) (b) and (5) (e) OF THE METROPOLITAN FIRE BRIGADES ACT 1958**

The Governor in Council, under section 41 (4) (b) and (5) (e) of the *Metropolitan Fire Brigades Act 1958*, fixes the rate of interest for the purposes of section 41 (4) (b) and (5) (e) at 13 per cent per annum to apply to amounts which first become due and payable under section 41 (4) (a) and section 41 (5) (d), respectively, on or after 1 July 1992.

Dated 23 June 1992

Responsible Minister:

M. SANDON

Minister for Police and Emergency Services

DAMIEN O'SHEA

20620 Acting Clerk of the Executive Council

**GOVERNMENT EMPLOYEE HOUSING AUTHORITY ACT 1981**

The Governor in Council under section 12 of the *Government Employee Housing Authority Act 1981* transfers properties held by the Minister for Police and Emergency Services to the Government Employee Housing Authority, as specified in the following list and which were omitted in the previous schedule dated 11 February 1992:

102 Highett Street, Mansfield

4 Arthur Street, Maryborough

22 Darling Street, Echuca

1 Howard Street, Bendigo

Dated 23 June 1992

Responsible Minister:

TONY SHEEHAN

Treasurer

DAMIEN O'SHEA

20470 Acting Clerk of the Executive Council

1662 G 25 1 July 1992

*Firearms Act 1958*  
*Control of Weapons Act 1990*  
DECLARATION OF A PREMISES TO BE A  
MUSEUM

His Excellency the Governor in Council under the provisions of the *Firearms Act 1958* and the *Control of Weapons Act 1990* hereby declares the Swan Island Historical Museum, Queenscliff to be a museum for the purposes of section 4 (1) (f) of the *Firearms Act 1958* and section 4 (3) of the *Control of Weapons Act 1990*.

Dated 23 June 1992

Responsible Minister:

MAL SANDON

Minister for Police and Emergency Services

DAMIEN O'SHEA

20620 Acting Clerk of the Executive Council

*Crown Land (Reserves) Act 1978*  
RESERVED CROWN LAND PLACED  
UNDER THE CONTROL AND  
MANAGEMENT OF MELBOURNE AND  
METROPOLITAN BOARD OF WORKS

The Governor in Council under section 18 (1) of the *Crown Land (Reserves) Act 1978* places under the control and management of Melbourne and Metropolitan Board of Works the following Crown land:

Firstly—An area of 4.92 hectares being Crown Allotment 28c, Parish of Keelbundora temporarily reserved as a site for the conservation of an area of natural beauty by Order in Council of 16 October 1979—(Rs 10, 248); and

Secondly—An area of 156.9 hectares, more or less, of land in the Parish of Keelbundora deemed to be permanently reserved as a site for the conservation of areas of natural interest by section 5 of the *Land (Miscellaneous) Act 1991*—(Rs 37002).

Dated 30 June 1992

Responsible Minister:

BARRY PULLEN

Minister for Conservation and Environment

DAMIEN O'SHEA

20090 Acting Clerk of the Executive Council

*Victoria Government Gazette*  
*Crown Land (Reserves) Act 1978*  
CROWN LAND TEMPORARILY  
RESERVED

The Governor in Council under sections 4 and 7 of the *Crown Land (Reserves) Act 1978* temporarily reserves for the purpose mentioned and also nominates as an area for which consent of the person or manager administering or managing the land is required before work may be done on that land in accordance with the *Mineral Resources Development Act 1990*, the following Crown land:

MUNICIPAL DISTRICT OF THE SHIRE OF  
WALPEUP

TIEGA—Conservation of an area of natural interest, 59.66 hectares being Crown Allotment 14E, Parish of Tiega as indicated by hatching on plan hereunder—(T222[5])(Rs 11028)

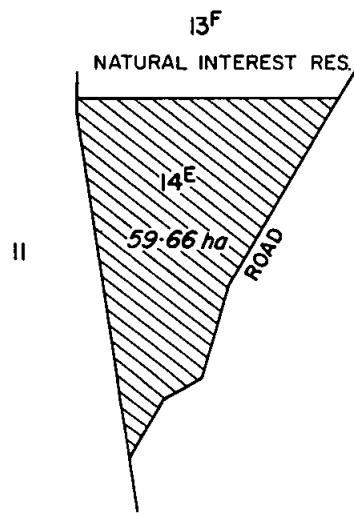

0 200 400 600  
METRES

Dated 30 June 1992

Responsible Minister:

BARRY PULLEN

Minister for Conservation and Environment

DAMIEN O'SHEA

20090 Acting Clerk of the Executive Council

NOTICE OF INTENTION

The Governor in Council under section 10 of the *Crown Land (Reserves) Act 1978* gives notice of intention to revoke the following temporary reservations:

**BENDIGO**—The temporary reservation by Order in Council of 8 January 1929 of 1323 square metres of land in Section 10c at Bendigo, Parish of Sandhurst as a site for Public Offices—(Rs 3805).

**BENDIGO**—The temporary reservation by Order in Council of 29 November 1960 of 8346 square metres of land in Section 10c at Bendigo, Parish of Sandhurst as a site for Municipal purposes, revoked as to part by Order in Council of 30 June 1981, so far only as the portion containing 120 square metres as indicated by hatching on plan hereunder—(Rs 3809).

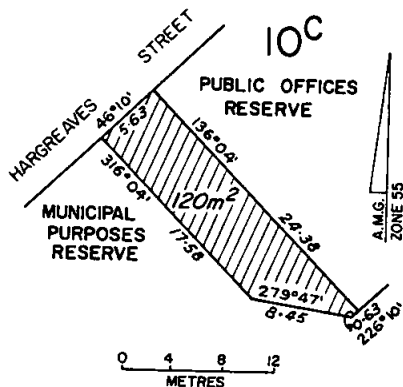

**CONEWARRE**—The temporary reservation by Order in Council of 2 February 1872 of 113.3 hectares, more or less, of land in the Parish of Conewarre as a site for Recreation purposes in addition to and adjoining the site temporarily reserved therefor by Order in Council of 8 May 1871 so far only as the portion containing 54 hectares, more or less, being Crown Allotment M, Section 28, Parish of Conewarre as indicated by hatching on plan hereunder—(B795[5 and 6]) (Rs 151).

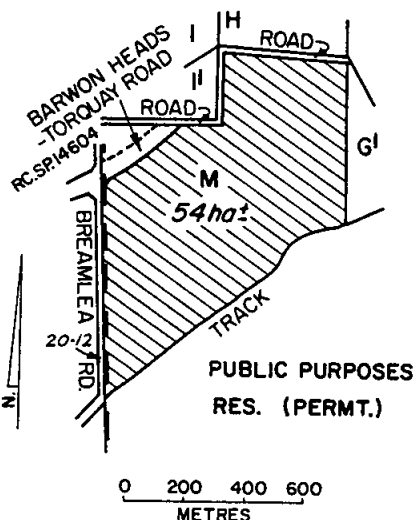

**DOWLING FOREST**—The temporary reservations for railway purposes by Order in Council of 23 November 1868 of the Crown lands comprised within the limits of deviation of the surveyed line of railway from Ballarat to Ararat and by Order in Council of 27 August 1888 of 9.3 hectares, more or less, of land in the Parishes of Cardigan and Dowling Forest so far only as the portion containing 767 square metres shown as Crown Allotment 10b, Section 3, Parish of Dowling Forest on Certified Plan No. 111230 lodged in the Central Plan Office—(Rs 912).

**GRENVILLE**—The temporary reservation by Order in Council of 23 October 1876, of 2023 square metres of land in the Township of Grenville (formerly in the Parish of Enfield) as a site for Public purposes (State School)—(Rs 13579).

**NAR-NAR-GOON**—The temporary reservation by Order in Council of 19 July 1988 of 983 square metres of land being Crown Allotment 43d, Parish of Nar-Nar-Goon as a site for Police Purposes—(Rs 13781).

**PORT MELBOURNE**—The temporary reservation by Order in Council of 19 January 1960 of 4965 square metres of land in Section 60, City of Port Melbourne, Parish of Melbourne South as a site for Police and Court House purposes—(Rs 7888).

1664 G 25 1 July 1992

Dated 30 June 1992

Responsible Minister:

BARRY PULLEN

Minister for Conservation and Environment

DAMIEN O'SHEA

20090 Acting Clerk of the Executive Council

*Crown Land (Reserves) Act 1978*  
CROWN LANDS TEMPORARILY  
RESERVED

The Governor in Council under sections 4 and 7 of the *Crown Land (Reserves) Act 1978* temporarily reserves for the purposes mentioned and also nominates as areas for which consent of the person or manager administering or managing the lands is required before work may be done on those lands in accordance with the *Mineral Resources Development Act 1990*, the following Crown lands:

MUNICIPAL DISTRICT OF THE SHIRE OF  
SOUTH GIPPSLAND

BENNISON—Conservation of native plants and animals, 2.362 hectares being Crown Allotment 21b, Township of Bennison, Parish of Wonga Wonga South as shown on Certified Plan No. 110340 lodged in the Central Plan Office—(14/6433).

MUNICIPAL DISTRICT OF THE SHIRE OF  
DUNMUNKLE

RUPANYUP—Conservation of an area of natural interest, 45 hectares, more or less, being Crown Allotments 135b and 135c, Parish of Rupanyup as indicated by hatching on plan hereunder—(R 76 [8]) (Rs 35066).

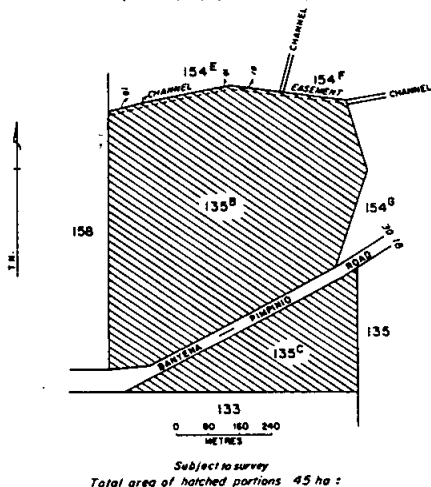

*Victoria Government Gazette*

MUNICIPAL DISTRICT OF THE SHIRE OF  
VIOLET TOWN

TAMLEUGH—Conservation of an area of natural interest, 2.026 hectares being Crown Allotment 1b, Section A, Parish of Tamleugh as indicated by hatching on plan hereunder—(T 150[A2])(Rs 10840).

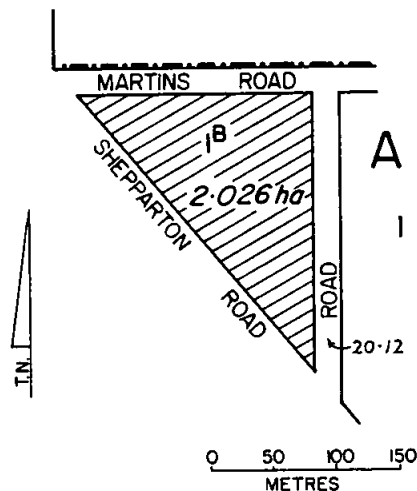

Dated 30 June 1992

Responsible Minister:

BARRY PULLEN

Minister for Conservation and Environment

DAMIEN O'SHEA

20090 Acting Clerk of the Executive Council

*Crown Land (Reserves) Act 1978*  
CROWN LAND PERMANENTLY  
RESERVED

The Governor in Council under sections 4 and 7 of the *Crown Land (Reserves) Act 1978* permanently reserves for the purpose mentioned and also nominates as an area for which consent of the person or manager administering or managing the land is required before work may be done on that land in accordance with the *Mineral Resources Development Act 1990*, the following Crown land:

MUNICIPAL DISTRICT OF THE SHIRE OF  
BARRABOOL

JAN JUC—Study of the natural environment and public purposes—

Firstly—An area of 291 hectares being Crown Allotments 52 and 56, Parish of Jan Juc as shown on Certified Plan No. 107032 lodged in the Central Plan Office; and



Secondly—An area of 4.9 hectares, more or less, being Crown Allotment 56A, Parish of Jan Juc as indicated by hatching on plan hereunder—(Rs 11591).

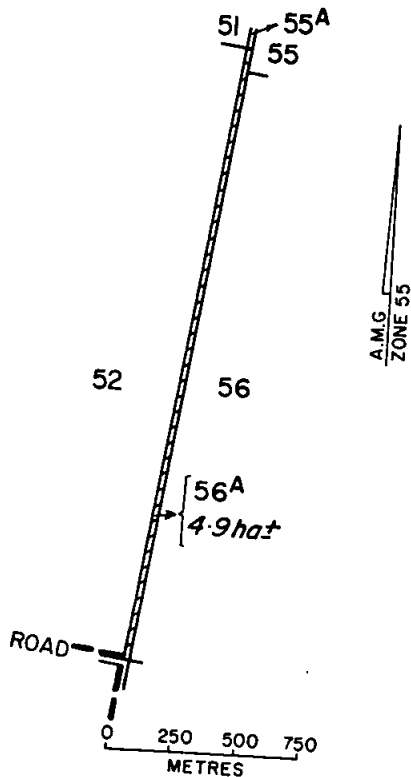

Dated 30 June 1992

Responsible Minister:

BARRY PULLEN

Minister for Conservation and Environment

DAMIEN O'SHEA

20090 Acting Clerk of the Executive Council

*Crown Land (Reserves) Act 1978*

NOTICE OF INTENTION

The Governor in Council under section 10 of the *Crown Land (Reserves) Act 1978* gives notice of intention to revoke the following temporary reservations:

ARARAT—The temporary reservation by Order in Council of 11 October 1950 of 1062 square metres of land in section 104A, Township of Ararat, Parish of Ararat as a site for Police purposes—(Rs 6594).

BENALLA—The temporary reservation by Order in Council of 20 July 1982, of 785 square metres of land being Crown Allotment 2A, section 23, Township of Benalla, Parish of Benalla as a site for Police purposes—(Rs 10942).

BENALLA—The temporary reservation by Order in Council of 5 November 1975 of 734 square metres of land being Crown Allotment 9A, section 4, Township of Benalla, Parish of Benalla as a site for Public purposes (Police purposes)—(Rs 10100).

BENALLA—The temporary reservation by Order in Council of 14 March 1979 of 805 square metres of land being Crown Allotment 11A, Section C, Parish of Benalla as a site for public buildings—(Rs 10770)

CANABORE—The temporary reservation under section 5 of the *Crown Land (Reserves) Act 1978* of 135.37 hectares of land being Crown Allotments 19 and 19A, Parish of Canabore transferred to the Crown by transfer No. P417934D registered in the Office of Titles on 8 September 1989 as a site for the growth and supply of timber, so far only as the portions containing 113.3 hectares shown as Crown Allotments 19B, 19C and 19D, Parish of Canabore on Certified Plan No. 111083 lodged in the Central Plan Office—(89/614).

CASTLEMAINE—The temporary reservation by Order in Council of 21 October 1980 of 1233 square metres of land being Crown Allotment 21, Section 140, Township of Castlemaine, Parish of Castlemaine as a site for Departmental residence—(Rs 10948)

CHEWTON—The temporary reservation by Order in Council of 15 July 1862 of 2656 square metres of land in the Parish of Chewton (formerly Allotment 75, Section F) as a site for Police purposes, revoked as to parts by Orders in Council of 12 July 1960 and 19 October 1971 so far as the balance remaining containing 1695 square metres, more or less—(Rs 8834)

DUNEED—The temporary reservation by Order in Council of 21 July 1981 of 658 square metres of land being Crown Allotment 14B, Parish of Duneed as a site for Departmental residence—(Rs 11434)

FRANKSTON—The temporary reservation by Order in Council of 4 December 1882 of 2.327 hectares of land in Section B, Township of Frankston, Parish of Frankston as a site for the use of the Railway Department, revoked as to part by Order in Council of 13 December 1948

1666 G 25 1 July 1992

Victoria Government Gazette

so far only as the portion containing 936 square metres shown as Crown Allotment 12c, Section B, Township of Frankston on Certified Plan No. 111286 lodged in the Central Plan Office—(Rs 6232).

**GLENMAGGIE**—The temporary reservation by Order in Council of 20 August 1985 of 1171 square metres of land being Crown Allotment 17A, Section 12, Township of Glenmaggie, Parish of Glenmaggie as a site for Departmental residence—(Rs 12662).

**HADDON**—The temporary reservation by Order in Council of 17 October 1870 of 8094 square metres of land (formerly part of Allotment 3, Section 11) Parish of Haddon as a site from whence stone may be procured—(Rs 13589)

**HOPETOUN**—The temporary reservation by Order in Council of 8 January 1980 of 1109 square metres of land being Crown Allotment 3, Township of Hopetoun, Parish of Goyura as a site for Police purposes—(Rs 10899)

**KEILOR**—The temporary reservation by Order in Council of 28 February 1956 of 5565 square metres, more or less, of land in Section 16, Township of Keilor, Parish of Maribymong as a site for Municipal Offices, Public Hall, Library and Infant Welfare Centre—(Rs 7432)

**KEILOR**—The temporary reservation by Order in Council of 29 June 1976 of 2134 square metres of land being Crown Allotment 1, Section 16, Township of Keilor, Parish of Maribymong as a site for Municipal Offices, Public Hall, Library and Infant Welfare Centre—(Rs 7432)

**KILMORE**—The temporary reservation by Order in Council of 15 January 1980 of 791 square metres of land being Crown Allotment 6, Section 36, Township of Kilmore, Parish of Bylands as a site for Teacher Housing Authority purposes—(Rs 9697).

**MOORA**—The temporary reservation by Order in Council of 30 June 1981 of 1150 square metres of land being Crown Allotment 112A, Parish of Moora as a site for Police purposes—(Rs 11506).

**MORDIALLOC**—The temporary reservation by Order in Council of 13 February 1945 of 7.81 hectares of land in the Parish of Mordialloc as a site for Hospital purposes and the temporary reservation by Order in Council of 8 January 1952 of 2.25 hectares, more or less, of land in the said Parish as a site for Hospital

purposes in addition to and adjoining the site temporarily reserved therefor by Order in Council of 13 February 1945, so far only as the portion containing 2.140 hectares shown as Crown Allotment 1D, Section 16, Parish of Mordialloc on Certified Plan No. 111026 lodged in the Central Plan Office—(Rs 8004).

**PORTLAND**—The temporary reservation by Order in Council of 9 November 1971 of 860 square metres of land in Section D, Township of Portland, Parish of Portland as a site for Public purposes (Departmental residence)—(Rs 9558).

**SALE**—The temporary reservation by Order in Council of 11 May 1965 of 736 square metres of land in Section 20, Township of Sale, Parish of Sale as a site for Public purposes (Police purposes)—(Rs 8304).

**ST. ARNAUD**—The temporary reservation by Order in Council of 4 March 1986 of 674 square metres of land being Crown Allotment 1A, Section K2, Township of St. Arnaud, Parish of St. Arnaud as a site for Police purposes—(Rs 12997).

**STRATHBOGIE**—The temporary reservation by Order in Council of 9 July 1963 of 228 square metres of land in Section B, Parish of Strathbogie as a site for the purposes of the Forests Act—(Rs 8229).

**WANGARATTA NORTH**—The temporary reservation by Order in Council of 25 May 1971 of 546 square metres of land in Section 7, Parish of Wangaratta North as a site for Public Purposes (Departmental residence)—(Rs 9479).

**WODONGA**—The temporary reservation by Order in Council of 17 August 1982 of 601 square metres of land being Crown Allotment 12D, Section 15, Parish of Wodonga as a site for Police purposes—(Rs 11785).

**WYCHEPROOF**—The temporary reservation by Order in Council of 17 August 1976 of 607 square metres of land being Crown Allotment 23N, Township of Wycheproof, Parish of Bunguluke as a site for Public Purposes (Departmental residence)—(Rs 10215)

Dated 30 June 1992

Responsible Minister:

BARRY PULLEN

Minister for Conservation and Environment

DAMIEN O'SHEA

20090 Acting Clerk of the Executive Council

*Crown Land (Reserves) Act 1978*  
REVOCATION OF TEMPORARY  
RESERVATIONS

The Governor in Council under section 10 of the *Crown Land (Reserves) Act 1978* revokes the following temporary reservations:

**CORINDHAP**—The temporary reservation by Order in Council of 14 May 1968 of 10.60 hectares of land in the Township of Corindhap, Parish of Corindhap as a site for water supply purposes—(Rs 8990).

**JIKA JIKA**—The temporary reservation by Order in Council of 23 January 1968 of 1366 square metres of land in Section 24 at Carlton, Parish of Jika Jika as a site for Public Purposes (Department of Health purposes)—(Rs 8902).

**MERRYMBUELA**—The temporary reservation by Order in Council of 18 November 1986 of 16.2 hectares, more or less, of land being Crown Allotment 2A, Parish of Merrymbuela as a site for the supply of stone—(Rs 13319).

**ST. ARNAUD**—The temporary reservation by Order in Council of 2 November 1977 of 1012 square metres of land being Crown Allotment 5, Section 13, Township of St. Arnaud, Parish of St. Arnaud as a site for public purposes (Departmental residence)—(Rs 10413).

Dated 30 June 1992

Responsible Minister:

**BARRY PULLEN**

Minister for Conservation and Environment  
**DAMIEN O'SHEA**

20090 Acting Clerk of the Executive Council

*Crown Land (Reserves) Act 1978*  
NOTICE OF INTENTION

The Governor in Council under section 10 of the *Crown Land (Reserves) Act 1978* gives notice of intention to revoke the following temporary reservations:

**HORSHAM**—The temporary reservation by Order in Council of 31 October 1972 of 1644 square metres, more or less, of land in Section 7, Township of Horsham, Parish of Horsham as a site for Public Purposes (Public Buildings)—(Rs 9253).

**HORSHAM**—The temporary reservation by Order in Council of 19 February 1877 of 2109 square metres of land in Section 7, Township of Horsham, Parish of Horsham as a site for the use of the Police Department—(Rs 1712).

**OUYEN**—The temporary reservation by Order in Council of 19 June 1940 of 6475 square metres of land in the Township of Ouyen as a site for the use of the State Rivers and Water Supply Commission, revoked as to part by various Orders, so far only as the portion containing 890 square metres shown as Crown Allotment 5A, Section 20, Township of Ouyen, Parish of Ouyen on Certified Plan No. 110299 lodged in the Central Plan Office—(Rs 5050).  
Dated 30 June 1992

Responsible Minister:

**BARRY PULLEN**

Minister for Conservation and Environment

**DAMIEN O'SHEA**

20090 Acting Clerk of the Executive Council

*Crown Land (Reserves) Act 1978*  
INCORPORATION OF THE COMMITTEE  
OF MANAGEMENT OF THE WARANGA  
CAMPING AND PUBLIC RECREATION  
RESERVE

The Governor in Council under section 14A (1) of the *Crown Land (Reserves) Act 1978* being satisfied that it is in the public interest to declare to be a corporation the Committee of Management appointed under section 14 (2) of the Act for the land described hereunder:

(a) declares that the Committee of Management shall be a corporation;

(b) assigns the name "Waranga Camping and Public Recreation Reserve Committee of Management Incorporated" to the corporation; and

under section 14B (3) of the Act, appoints Kenneth Michael McMahon to be the Chairperson of the Committee.

Land Description—The remaining land in the Parish of Waranga temporarily reserved as a site for camping and Public Recreation by Order in Council of 16 February 1965 (*Government Gazette* 24 February 1965) being Crown Allotment 74B, No Section, Parcel No. 06/99/P124825.

Dated 30 June 1992

Responsible Minister:

**BARRY PULLEN**

Minister for Conservation and Environment

**DAMIEN O'SHEA**

20090 Acting Clerk of the Executive Council

1668 G 25 1 July 1992

*Crown Land (Reserves) Act 1978*  
REVOCATION OF TEMPORARY  
RESERVATIONS

The Governor in Council under section 10 of the *Crown Land (Reserves) Act 1978* revokes the following temporary reservations:

DANDENONG—The temporary reservation by Order in Council of 5 April 1977, of 232 square metres of land being Crown Allotment 43A, Parish of Dandenong as a site for Public Purposes (Mental Health Authority purposes)—(Rs 10230).

DANDENONG—The temporary reservation by Order in Council of 7 December 1968, of 1543 square metres of land in the Parish of Dandenong as a site for Public Purposes (Mental Health Authority purposes)—(Rs 9094).

DANDENONG—The temporary reservation by Order in Council of 5 December 1978, of 798 square metres of land being Crown Allotment 43B, Parish of Dandenong as a site for Public Purposes (Mental Health Authority purposes)—(Rs 9094).

MINIMAY—The temporary reservation by Order in Council of 13 November 1956, of 6070 square metres of land in the Township of Minimay, Parish of Minimay as a site for a Rubbish Depot—(Rs 7508).

NI NI—The temporary reservation by Order in Council of 4 November 1906, of 1.214 hectares of land in the Parish of Ni Ni (formerly part of Allotment 95) as a site for a Cemetery—(02-6161)

Dated 30 June 1992

Responsible Minister:

BARRY PULLEN

Minister for Conservation and Environment  
DAMIEN O'SHEA

20090 Acting Clerk of the Executive Council

*Victoria Government Gazette*

(a) declares that the Committee of Management shall be a corporation;

(b) assigns the name "Whittlesea Showgrounds and Recreation Reserves Committee of Management Incorporated" to the corporation; and

under section 14B (3) of the Act, appoints Peter John Towt to be Chairperson of the corporation.

Schedule

Allotments 3A and 3B, Section 23 in the Township of Whittlesea, temporarily reserved for Public Recreation by Order in Council of 1 September 1987 (vide *Government Gazette* 2 September 1987).

Reserved Crown land in the Township of Whittlesea, Parish of Toorourrong as is indicated by yellow and blue colours on plan "W.A/3.8.39" attached to Department of Conservation and Environment file Rs 2111.

Land in the Township of Whittlesea temporarily reserved for Agricultural Showgrounds by Order in Council of 10 October 1905 (vide 18 October 1905) and the additional purpose of Public Recreation by Order in Council of 19 May 1954 (vide *Government Gazette* 26 May 1954)—Rs 2491.

Land in the Township of Whittlesea temporarily reserved for cricket and other purposes of Public Recreation by Order in Council of 23 May 1906 and 30 July 1907 (vide *Government Gazette* 30 May 1906 and 7 August 1907)—Rs 937.

Dated 30 June 1992

Responsible Minister:

BARRY PULLEN

Minister for Conservation and Environment  
DAMIEN O'SHEA

20090 Acting Clerk of the Executive Council

*Crown Land (Reserves) Act 1978*  
INCORPORATION OF COMMITTEE OF  
MANAGEMENT OF THE WHITTLESEA  
SHOWGROUNDS, PUBLIC PARK AND  
RECREATION RESERVE

The Governor in Council, under section 14A (1) of the *Crown Land (Reserves) Act 1978*, being satisfied that it is in the public interests to declare to be a corporation the Committee of Management appointed under section 14 (2) of the Act of the land described in the schedule hereunder:

*Land Act 1958*  
UNUSED ROADS CLOSED

The Governor in Council under section 349 of the *Land Act 1958* and with the consents in writing of the municipalities concerned closes the following unused roads:

MUNICIPAL DISTRICT OF THE BOROUGH  
OF EAGLEHAWK

EAGLEHAWK—The road at Eaglehawk, Parish of Sandhurst as indicated by hatching on plan hereunder—(2473-3) (P 126 108).

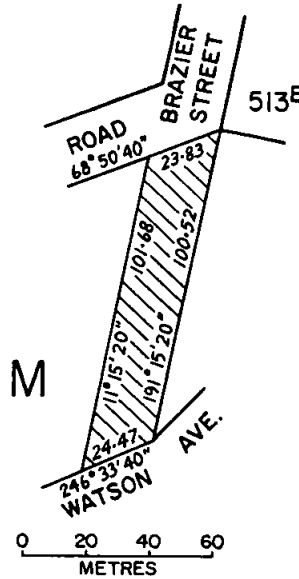
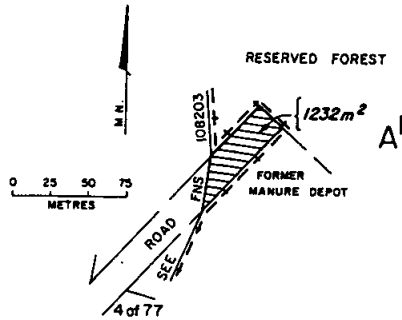

**MUNICIPAL DISTRICT OF THE CITY OF KEILOR**

KEILOR—The road in the Township of Keilor, Parish of Maribyrnong as indicated by hatching on plan hereunder—(K24[2]) (Rs 3755).

Dated 30 June 1992  
 Responsible Minister:  
 BARRY PULLEN  
 Minister for Conservation and Environment  
 DAMIEN O'SHEA  
 20090 Acting Clerk of the Executive Council

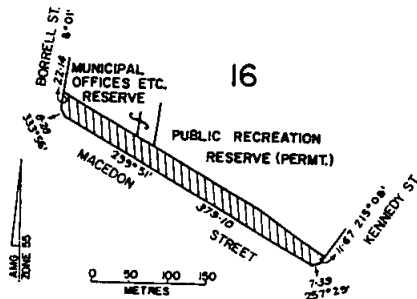

*Land Act 1958*  
**UNUSED ROAD CLOSED**  
 The Governor in Council under section 349 of the *Land Act 1958* and with the consent in writing of the municipality concerned and the adjoining owners closes the following unused road:

**MUNICIPAL DISTRICT OF THE CITY OF DONCASTER AND TEMPLESTOWE**  
 WARRANDYTE—The road in the Township of Warrandyte, Parish of Warrandyte shown as Crown Allotment 36A, Section 15 on Certified Plan No. 107908 lodged in the Central Plan Office—(L11-4071)

Dated 30 June 1992  
 Responsible Minister:  
 BARRY PULLEN  
 Minister for Conservation and Environment  
 DAMIEN O'SHEA  
 20090 Acting Clerk of the Executive Council

**MUNICIPAL DISTRICT OF THE CITY OF MARYBOROUGH**

MARYBOROUGH—The road in the Parish of Maryborough as indicated by hatching on plan hereunder—(M66[19]) (90-1307).

1670 G 25 1 July 1992

**LAND ACT 1958**

The Governor in Council under section 22A (4) of the *Land Act 1958* amends the metes and bounds prescribed in Part 1 (a) of the Second Schedule to the *Port of Geelong Authority Act 1958* by excision therefrom of the lands in the City of Geelong and the Parishes of Corio, Moolap and Moorpanyal coloured yellow on plans marked Corio 2500/13.12, Corio 2500/13.13, Corio 2500/13.14 and Corio 2500/14.12 attached to Department of Conservation and Environment correspondence No. L1-3948.  
Dated 30 June 1992

Responsible Minister:

BARRY PULLEN

Minister for Conservation and Environment

DAMIEN O'SHEA

20090 Acting Clerk of the Executive Council

*Trustee Act 1958*

**REVOCATION UNDER SECTION 4 (5)**

Under the power given in section 4 (5) of the *Trustee Act 1958* the Governor in Council by this Order revokes the declaration dated 13 September 1983 declaring Capital Building Society and Victorian Savings and Loan Society to be societies with which a Trustee may make deposits or term deposits.

Dated 30 June 1992

Responsible Minister:

JAMES HARLEY KENNAN

Attorney-General

DAMIEN O'SHEA

20430 Acting Clerk of the Executive Council

*Hospitals and Charities Act 1958*

**APPROVAL OF GRANTING OF LEASE**

The Governor in Council pursuant to section 66 (2) of the *Hospitals and Charities Act 1958*, being satisfied that the granting of a lease by Berry Street Child and Family Care to the East Melbourne Child Care Co-operative Inc. would be beneficial, approves the granting of such lease.

Dated 30 June 1992

Responsible Minister:

K. SETCHES

Minister for Community Services and

Minister Responsible for Child Care

DAMIEN O'SHEA

20080 Acting Clerk of the Executive Council

*Victoria Government Gazette*

*Mineral Resources Development Act 1990*

**REVOCATION OF EXCEPTION FROM MINING**

The Governor in Council under Schedule 2 item 4 (3) of the *Mineral Resources Development Act 1990*, revokes the exception from mining for certain land in section VI, Township of Egerton, Parish of Bungal, County of Grant excepted by Order of 16 September 1912 and published in the *Government Gazette* of 25 September 1912 page 3933 taken to be exempted land under Schedule 2 item 4 (1) of the *Mineral Resources Development Act 1990*.  
Dated 30 June 1992

Responsible Minister:

DAVID WHITE

Minister for Manufacturing and Industry Development

DAMIEN O'SHEA

20400 Acting Clerk of the Executive Council

*Lotteries, Gaming and Betting Act 1966*

**APPOINTMENT OF CHAIRPERSON AND MEMBERS OF RAFFLES AND BINGO PERMITS BOARD**

The Governor in Council under section 5A of the *Lotteries Gaming and Betting Act 1966* appoints the following as Chairperson and Members of the Raffles and Bingo Permits Board for the period 1 July 1992 to 31 October 1992:

Chairperson: John Milton Dugan.

Members: John Frame, Andrew Oddy.

Dated 30 June 1992

Responsible Minister:

NEIL TREZISE

Minister for Sport and Recreation

DAMIEN O'SHEA

20740 Acting Clerk of the Executive Council

*Racing Act 1958*

**APPOINTMENT OF CHAIRPERSON AND MEMBERS OF THE GREYHOUND RACING GROUNDS DEVELOPMENT BOARD**

The Governor in Council acting with the advice of the Executive Council pursuant to the powers conferred by section 83A of the *Racing Act 1958* appoints Thomas Miller Hogg to be Chairperson of the Greyhound Racing Grounds Development Board for the period 1 July 1992 to 31 December 1992 and William Collins and Joan Rodda to be members of the Greyhound

*Victoria Government Gazette*

G 25 1 July 1992 1671

Racing Grounds Development Board for the  
period 1 July 1992 to 30 June 1995.

Dated 30 June 1992

Responsible Minister:

NEIL TREZISE

Minister for Sport and Recreation

DAMIEN O'SHEA

20740 Acting Clerk of the Executive Council

---

*Racing Act 1958*

APPOINTMENT OF CHAIRPERSON OF  
RACECOURSES LICENCES BOARD

The Governor in Council acting with the  
advice of the Executive Council and pursuant to  
the powers conferred by section 34 of the Racing  
Act appoints Thomas Miller Hogg to be  
Chairperson of the Racecourses Licences Board  
for the period 1 July 1992 to 31 December 1992.

Dated 30 June 1992

Responsible Minister:

NEIL TREZISE

Minister for Sport and Recreation

DAMIEN O'SHEA

20740 Acting Clerk of the Executive Council

---

**PRIVATE  
ADVERTISEMENTS**

**CITY OF ARARAT**

Notice is hereby given that the Council of the City of Ararat has adopted the following Local Laws pursuant to the *Local Government Act* 1989, which will come into force on 1 October 1992. The Local Laws are for the following purposes—

Local Law No. 24

Processes of Municipal Government  
(Procedures for Meetings)

The objectives of this Local Law are:

- (a) to provide a mechanism to facilitate the good government of the City of Ararat through its formal meeting procedure to ensure effective and efficient Council decisions are made in a manner which acknowledges the role of local government within the Australian system of government;
- (b) to promote and encourage community participation in the system of local government by providing mechanisms for the Council to ascertain the community's views and expectations;
- (c) to regulate and control the election of Mayor;
- (d) to regulate and control the procedures governing the conduct of meetings including:
  - (i) the notice required for meetings;
  - (ii) the keeping of minutes;
- (e) to regulate and control the use of the Council's seal;
- (f) to provide for the administration of the Council's powers and functions; and
- (g) to provide generally for the peace, order and good government of the municipal district.

Local Law No. 25

Street Numbering of Premises

The objective of this Local Law is to establish the requirement for and a standard of street numbering for all premises in the City of Ararat, in order to ensure the accurate identification and easy location of all such premises.

A copy of each of these Local Laws can be obtained from the Municipal Office building,

corner, of Vincent and High Streets, Ararat, during office hours.

LYNDEN J. SMITH

18852. Town Clerk

Planning and Environment Act 1987  
BROADMEADOWS PLANNING SCHEME  
Approval of Amendment to a Planning Scheme  
Amendment L.29

The Minister for Planning approved Amendment L.29 on 4 June 1992. The amendment affects Part Lot 2, being 1059 Pascoe Vale Road, Broadmeadows.

The approved amendment will change the planning scheme by rezoning the lot from Existing Main Road Reservation to District Centre Broadmeadows Zone.

S. GORE

Acting Chief Executive Officer  
City of Broadmeadows

18853

**CITY OF COHUNA**

Local Law No. 1

Processes of Municipal Government  
(Procedures for Meetings) Local Law

Notice is given that the Council of the Shire of Cohuna, at its ordinary meeting held on Monday, 18 May 1992 having considered submissions received pursuant to section 223 of the *Local Government Act* 1989 resolved pursuant to section 119 of the Act to pass the Local Law known as the Shire of Cohuna Processes of Municipal Government (Procedures for Meetings) Local Law.

The purpose and general purport of Local Law No. 1 includes:

- Regulating and Control of:  
Procedures for Council Meetings  
Election of Mayor  
Use of Council's Seal

A copy of Local Law No. 1 of the Shire of Cohuna is available for inspection during office hours: (8 a.m. to 4.45 p.m.) at the Shire Offices, King Edward Street, Cohuna 3568.

P. TONKIN

18889 Acting Shire Secretary



*Victoria Government Gazette*  
CITY OF COHUNA  
Local Law No. 2  
Environment

Notice is given that the Council of the Shire of Cohuna, at its ordinary meeting held on Monday, 18 May 1992 having considered submissions received pursuant to section 223 of the *Local Government Act 1989* resolved pursuant to section 119 of the Act to pass the Local Law known as the Shire of Cohuna Environment Law.

The purpose and general purport of Local Law No. 1 includes:

- Provide a Safe and Healthy Environment
- Control and Regulate Activities which may be Detrimental to the Quality of Life
- Control Nuisances, Noise, Odour, Smoke Emissions etc.
- Regulate the Use of Recreational Vehicles
- Regulate and Control for Swimming Pools:
  - Advertising
  - Animals etc.

A copy of Local Law No. 2 of the Shire of Cohuna is available for inspection during office hours: (8 a.m. to 4.45 p.m.) at the Shire Offices, King Edward Street, Cohuna 3568.

P. TONKIN  
18890 Acting Shire Secretary

*Planning and Environment Act 1987*  
FRANKSTON PLANNING SCHEME  
Notice of Amendment to a Planning Scheme  
Amendment L39

The City of Frankston has prepared Amendment L39 to the Local Section of the Frankston Planning Scheme.

The amendment proposes to rezone land at 2 Golf Links Road, Frankston from Residential "C" and Frankston Residential 2 to Residential "C", Reserved—Public Open Space and Reserved—Secondary Road.

The amendment can be inspected at City of Frankston Town Planning Section, Civic Centre, Davey Street, Frankston, Victoria 3199; Department of Planning and Housing, Ground Floor, The Olderfleet Buildings, 477 Collins Street, Melbourne; Department of Planning and Housing, Metropolitan South and Western Port Region, 33-39 High Street, Cranbourne, Victoria 3977.

Submissions about the amendment must be sent to Chief Executive Officer, City of

G 25 1 July 1992 1673  
Frankston, PO Box 490, Frankston 3199;  
Attention: Town Planner by 31 July 1992.

R. HEAD  
18919 Town Planner

CITY OF GEELONG  
Loan No. 105

Melbourne and Geelong Debentures  
Inscribed Stock and Mortgages Acts

Notice is hereby given that the Council of the City of Geelong intends to borrow the principal sum of \$22 000 for the purpose of refinancing the outstanding balance of Loan No. 77 maturing 18 August 1992. The period of the loan shall be four years at the end of which period the term of the loan may be extended for a further two years. Repayments of the loan will be by equal half yearly instalments based on a six year repayment schedule. The rate of interest payable during the term of the loan will be prescribed by Department of the Treasury in respect of Smaller Authority Loans.

J. B. BLEAZBY  
18921 Acting Town Clerk

CITY OF KEILOR  
Local Law

The Council of the City of Keilor proposes to make Local Law No. 8—Environmental Health (Animals and Birds).

This Local Law regulates the keeping of dogs, cats, other animals, domestic birds, poultry, birds, other birds, bees, rodents and reptiles. The Local Law refers specifically to such matters as the Title, Purpose, Commencement and Revocation dates of the Local Law, provides definitions of terms used. It also outlines the requirements for a permit, types of permits and the application forms, conditions attached to permits in relation to the numbers and where and how they are kept, and details offences and penalties for contraventions.

A copy of the proposed Local Law No. 8—Environmental Health (Animals and Birds) can be obtained from the Council Offices, Old Calder Highway, Keilor, during office hours.

Any person affected by this Local Law may, within fourteen (14) days after publication of this notice, make to the Council a submission in writing which will be considered by Council in accordance with section 223 of the *Local Government Act 1989*, at a meeting commencing at 7.30 p.m. on 21 July 1992.

JOHN R. CASTLE  
18903 Town Clerk

1674 G 25 1 July 1992

**CITY OF KEILOR  
Local Law**

Notice is hereby given that the Council of the City of Keilor at its meeting held on 23 June 1992, made Local Law No. 15—"Keilor Municipal Golf Course".

This Local Law regulates the use of the Keilor Municipal Golf Course and refers specifically to such matters as the Title, Purpose, Commencement and Revocation of the Local Law, provides definitions of terms used, specifies use of the golf course, times of use, fees and charges, conduct of persons whilst within the confines of the golf course and offences and penalties.

A copy of the Local Law No. 15 may be inspected at the Municipal Offices, Old Calder Highway, Keilor, during office hours.

**JOHN R. CASTLE**  
Town Clerk

18904

*Victoria Government Gazette*

entertainment facilities of metropolitan significance and those areas which provide for residential living and the local shopping needs of the community.

A copy of the amendment can be inspected free of charge, during office hours at the Department of Planning and Housing, Ground Floor, 477 Collins Street, Melbourne and the City of Melbourne, City Planning and Development, 3rd and 7th Floors, 200 Little Collins Street, Melbourne.

If you wish to make a submission or lodge an objection to the provisions of the amendment please write to: Ms Laurinda Gardner, Manager—Strategic Planning, City of Melbourne, GPO Box 1603M, Melbourne by 14 August 1992.

**JOHN NOONAN**  
Manager

18874

City Planning and Development

*Planning and Environment Act 1987*  
**MELBOURNE PLANNING SCHEME**  
Notice of Amendment  
Amendment L79

The City of Melbourne has prepared Amendment No. L79 to the Local Section of the Melbourne Planning Scheme. The amendment affects land in the following Melbourne Planning Scheme zones which are located generally in the area shown on the map.

Clause No.	Zone Name
105	Melbourne Commercial & Industrial 1B5
106	Melbourne Local Business 1B1
107	Melbourne Office 1B7
115	Melbourne Residential & Service 1R5

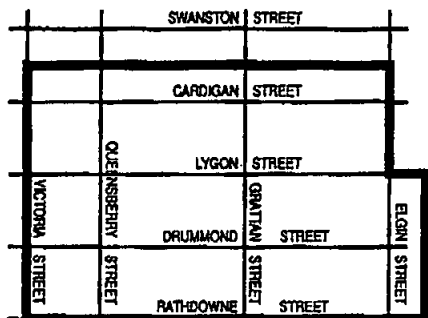

The purpose of this amendment is to segregate conflicting land use in mixed use zones between areas which encourage the development of a range of eating and

*Planning and Environment Act 1987*  
**NUNAWADING PLANNING SCHEME**  
Notice of Amendment to a Planning Scheme  
Amendment L44

The City of Nunawading has prepared Amendment L44 to the Nunawading Planning Scheme.

The amendment affects land between Springvale Road and Boronia Road, City of Nunawading, designated as the corridor for the proposed Healesville Freeway.

The amendment proposes to change the Nunawading Planning Scheme by rezoning the subject land from Proposed Main Road to Part Reserved Living and Part Proposed Public Open Space.

The amendment can be inspected at City of Nunawading, Civic Centre, 379 Whitehorse Road, Nunawading; the Department of Planning and Housing, The Olderfleet Buildings, 477 Collins Street, Melbourne; the Department of Planning and Housing, Eastern Office, 38-40 Prospect Street, Box Hill.

Submissions regarding the amendment must be sent to Manager, Strategic Planning, City of Nunawading, P.O. Box 15, Nunawading by 3 August 1992.

**GEOFF RUNDELL**  
Manager, Strategic Planning

18861

Victoria Government Gazette

CITY OF PRAHRAN  
Signs and Goods on Roads  
Local Law No. 6

Notice is given that the Council of the City of Prahran (under the provisions of the *Local Government Act 1989*) at its ordinary meeting held on 22 June 1992 made and passed a Local Law.

The title of the Local Law is the "Signs and Goods on Roads" Local Law No. 6.

The purpose and general purport of the Local Law is to regulate and control the placing of advertising signs, goods, tables, chairs and like things on roads.

A copy of the Local Law is available or can be inspected at the Town Hall, corner Chapel and Greville Streets, Prahran between the hours of 9.00 a.m. and 5.00 p.m. The Local Law comes into operation on 13 July 1992.

D. G. JESSON  
Town Clerk

18880

CITY OF PRAHRAN  
Signs and Goods on Roads  
Local Law No. 6

Notice is given that the Council of the City of Prahran (under the provisions of the *Local Government Act 1989*) at its ordinary meeting held on 22 June 1992 made and passed a Local Law.

The title of the Local Law is the "Signs and Goods on Roads" Local Law No. 6.

The purpose and general purport of the Local Law is to regulate and control the placing of advertising signs, goods, tables, chairs and like things on roads.

A copy of the Local Law is available or can be inspected at the Town Hall, corner Chapel and Greville Streets, Prahran between the hours of 9.00 a.m. and 5.00 p.m. The Local Law comes into operation on 13 July 1992.

D. G. JESSON  
Town Clerk

18883

CITY OF PRESTON  
Road Discontinuance

Pursuant to section 528 (2) of the *Local Government Act 1958*, the Council of the City of Preston at its Ordinary Meeting of Council held on 13 April 1992, resolved that the roads shown hatched on the plans below, be discontinued and sold by private treaty.

G 25 1 July 1992 1675

"That notwithstanding such discontinuance the Council and Melbourne Water shall continue to have and possess the same right, title, power, authority or interest in or in relation to the whole of the lands shown by hatching on the said plans as it has or possessed prior to such discontinuance with respect to or in connection with any drains or pipes laid or erected in on or over such lands for the purposes of drainage or sewerage."

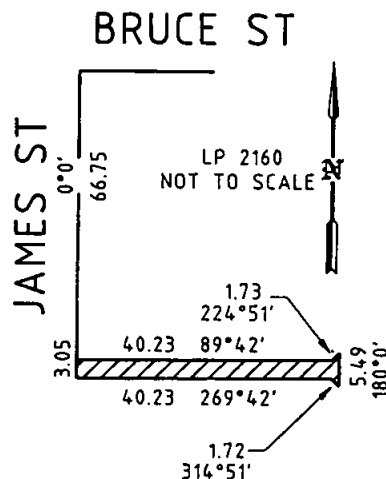
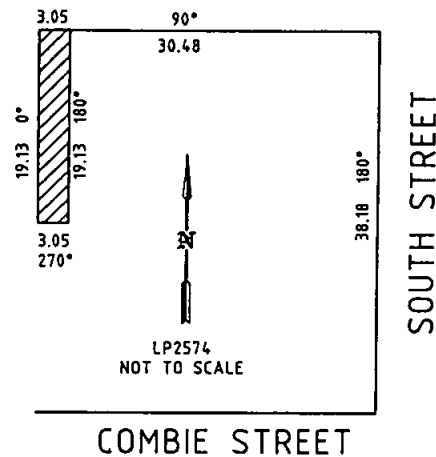

1676 G 25 1 July 1992

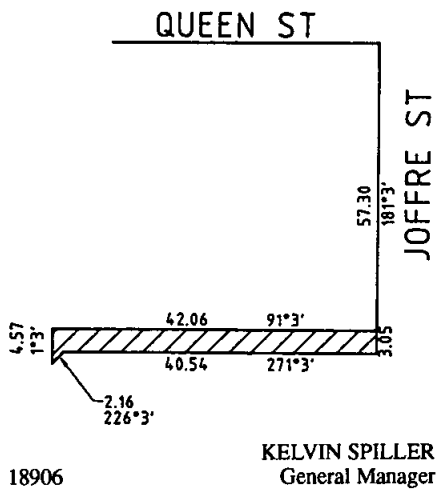

*Planning and Environment Act 1987*  
**SOUTH MELBOURNE PLANNING  
 SCHEME**  
 Notice of Abandonment  
 Amendment L45

The City of South Melbourne has prepared Amendment L45. At its meeting of 22 June 1992, Council resolved to formally abandon Amendment L45 which proposed to change the zoning of 276 Richardson Street, Middle Park from part Residential C part Local Business to the entire property being zoned Residential C.

NOEL F. KROPP  
 18885 Chief Executive Officer and Town Clerk

**CITY OF SPRINGVALE**  
 Road Discontinuance

Pursuant to section 528 (2) of the *Local Government Act 1958* and after having given notice of the proposed discontinuance in accordance with the Act, the council of the City of Springvale, at its ordinary meeting on 22 June 1992, resolved that the portion of Lainie Avenue, Keysborough, as shown hatched on the attached plan, is no longer required for the purpose for which it was created and that it be discontinued and sold by private treaty.

Victoria Government Gazette

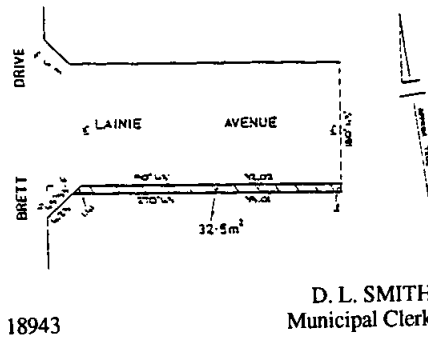

**CITY OF SWAN HILL**  
 Local Law Part 11

Notice is hereby given that the Council of the City of Swan Hill at its meeting on 23 June 1992, made Local Law Part 11, titled Street Trading and Collections, for the following purposes:

- (a) Provide opportunities for traders or vendors to sell goods and services on roads, and public places, but not so as to detrimentally affect the retailing of similar goods or services by persons who own or occupy shops in the municipal district.
- (b) Regulate the sale of goods and services on roads and public places.
- (c) Regulate the soliciting and collection of gifts of money or subscriptions for any purpose on roads and public places.

A copy of the Local Law may be inspected at the Municipal Offices, Nyah Road, Swan Hill during office hours.

G. J. MENNIE  
 18909  
 Town Clerk

**CITY OF SUNSHINE**  
 Road Discontinuance

Pursuant to section 528 (2) of the *Local Government Act 1958* (as amended), the Council of the City of Sunshine, at its ordinary meeting of council, held on 22 June 1992, resolved that section of the roads known as Sussex Street and Middlesex Street (between Cumberland Street and Duke Street) and Nottingham Street (between Suffolk Road and Middlesex Street), which is shown by hatching and cross-hatching on the plan herewith, be discontinued subject to:

ALBERTON PLANNING SCHEME

Notice of Amendment to a Planning Scheme  
Amendment L20

- (a) Melbourne Water continuing to have and possess the same right, title, power, authority or interest in or in relation to the whole of the land shown by hatching on the said plan as it had or possessed prior to such discontinuance with respect to or in connection with any drains or pipes laid or erected in on or over such land for the purpose of drainage or sewerage and by the creation of an easement over the whole of the land formerly known as Middlesex Street, and a 6 metre wide easement over the length of drain which crosses Sussex Street, shown by cross-hatching on the plan;
- (b) The land in the said road subject to any such right, title, power, authority or interest vesting in the municipality to be retained by it until sold by private treaty.

The Shire of Alberton has prepared Amendment L20 to the Alberton Planning Scheme.

The amendment affects land currently in a "New Minor Road" Reservation, and the Industrial "A" zone, under the Planning Scheme.

The land is located between Rodgers and Wesley Streets, Yarram, and has frontages to Commercial Road and Grant Street. The Reservation is a proposed "U" shaped laneway, some of which is shown on titles as a road, and some of which is in private ownership.

The proposed laneway is not required by some of the abutting owners, who wish the reservation to be abandoned by this amendment.

In addition to removing the reservation, the amendment proposes to take land in the area out of the Industrial "A" zone and to place it in the Commercial "A" zone, as this land is proximate to land in the Residential "A" zone, and there is an incompatibility between permissible residential and industrial zone uses.

The amendment will establish non-conforming-use rights to existing uses which are classified by the scheme as "Industrial Uses".

The amendment proposes to change the Planning Scheme by amending the planning scheme maps (Local Section, Map E), to show the rezoning.

It is proposed to do the following:

Rezone Industrial "A" zoned land, to the Commercial "A" zone.

Rezone most of the New Minor Road Reservation to the Commercial "A" zone.

Rezone a small strip of the New Minor Road Reservation (northern side of amendment area) to the Residential "A" zone, to ensure alignment between the zone and title boundaries.

The amendment can be inspected at the Department of Planning and Housing, The Olderfleet Buildings, 477 Collins Street, Melbourne; the Department of Planning and Housing, 71 Hotham Street, Traralgon; Latrobe Regional Commission, 42 Grey Street, Traralgon; the Shire of Alberton, Commercial Road, Yarram.

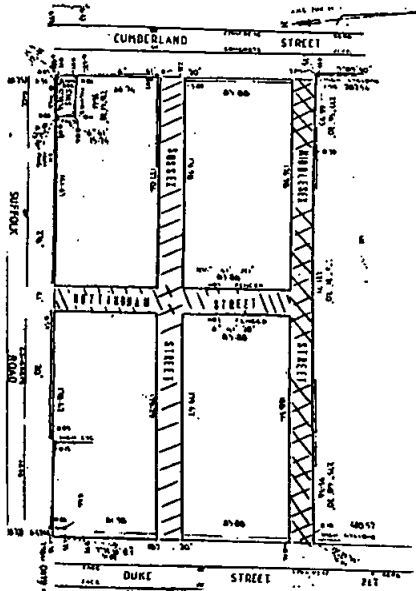

JOHN JAMES  
Chief Executive Officer/  
Town Clerk

1678 G 25 1 July 1992

Submissions are invited and must be sent to the Shire of Alberton, Commercial Road, Yarram 3971 before 10 August 1992.

VICTOR OGILVIE  
Acting Town Planner  
18869

*Planning and Environment Act 1987*

ALBERTON PLANNING SCHEME

Notice of Amendment to a Planning Scheme  
Amendment L21

The Shire of Alberton has prepared Amendment L21 to the Alberton Planning Scheme.

The amendment affects vacant land (Lot 2, L.P. 5804, Section 5, Parish of Yarram), owned by Tarra Lodge, in Nichol Street, Yarram and proposes to rezone it from a Special Use 6 (Freemasons Hall), to the Residential "A" zone. The land is a vacant allotment on the south side of the Freemasons Hall.

The amendment proposes to change the Planning Scheme by amending the planning scheme maps (Local Section Map E), to show the rezoning.

The amendment can be inspected at the Department of Planning and Housing, The Olderfleet Buildings, 477 Collins Street, Melbourne; the Department of Planning and Housing, 71 Hotham Street, Traralgon; Latrobe Regional Commission, 42 Grey Street, Traralgon; the Shire of Alberton, Commercial Road, Yarram.

Submissions are invited and must be sent to the Shire of Alberton, Commercial Road, Yarram 3971 before 10 August 1992.

Dated 17 June 1992

VICTOR OGILVIE  
Acting Town Planner  
18870

SHIRE OF AVOCA

Processes of Municipal Government  
(Procedure for Meetings)

Local Law No. 2

Notice is hereby given that on 17 June 1992 Council made Local Law No. 2.

The Local Law No. 2 will operate as from 2 July 1992.

The purpose and general purport of the Local Law is to regulate Council meeting procedures and the use of its Common Seal.

*Victoria Government Gazette*

A copy of the Local Law can be inspected at the Shire Office, Rutherford Street, Avoca, during business hours.

KEN W. SHEARER  
Shire Secretary  
18875

SHIRE OF BACCHUS MARSH

Proposed Local Laws

Notice is hereby given that the Council intends to make Local Laws which are titled:

Local Law No. 4 Streets and Roads

Local Law No. 5 Keeping of Animals and Birds

Local Law No. 6 Swimming Pools (Public)

Local Law No. 7 Sale of Goods

Local Law No. 8 Recreation Vehicles.

The proposed Streets and Roads Local Law provides for—

management of roads for traffic;  
control of vehicles and animals on roads;  
secondary activities on roads, e.g. advertising signs;

management of parking;

enforcement and penalties.

The proposed Local Law for keeping of animals and birds provides for—

control and regulation of dogs, cats, bees, birds, horses and other animals;

enforcement and penalties.

The proposed Local Law for control of public swimming pools provides for—

hygiene;

pool supervision, rules and conduct;

times of operation;

enforcement and penalties.

The proposed Local Law for Sale of Goods provides for—

sales of goods including animals and birds from vehicles and other non-permanent structures in public places and vacant land;

permits for distribution of advertising literature;

enforcement and penalties.

The proposed Local Law for Recreation Vehicles provides for—

control and use of recreational vehicles on private and public land;

enforcement and penalties.

Copies of the proposed Local Laws can be obtained on enquiry at the Shire Offices during office hours.

Any person affected by this proposed amendment may make a written submission to Council under section 223 of the *Local Government Act* 1989. Such submission should be submitted within 14 days of this notice.

Any person making a written submission may request to be heard in person in support of their submission by appearing before the Council at a meeting scheduled to be held on Thursday, 23 July 1992.

18900

IAN D. MORRIS  
Shire Secretary

*Planning and Environment Act 1987*  
BRIGHT PLANNING SCHEME

Notice of Amendment to a Planning Scheme  
Amendment L25

The Shire of Bright has prepared Amendment L25 to the Bright Planning Scheme.

The amendment proposes to change Chapter 2 (Ovens Valley and Kiewa Valley) of the Local Section of the Bright Planning Scheme by replacing the existing Rural Residential Zone with two new Rural Residential Zones and accompanying new controls.

The amendment can be inspected at Shire of Bright, Municipal Offices, Churchill Avenue, Bright; Department of Planning and Housing, The Olderfleet Buildings, 477 Collins Street, Melbourne; and at the Department of Planning and Housing, Northeast-Goulburn Region Office, 1 McKoy Street, West Wodonga.

Submissions about the amendment must be sent to Shire of Bright, Municipal Offices, P.O. Box 139, Bright 3741: Attention: the Town Planner, by 29 July 1992.

Dated 17 June 1992

18836

R. M. SLAPP  
Town Planner  
Shire of Bright

*Planning and Environment Act 1987*  
BRIGHT PLANNING SCHEME

Notice of Amendment to a Planning Scheme  
Amendment L26

The Shire of Bright has prepared Amendment L26 to the Bright Planning Scheme.

The amendment proposes to change Chapter 2 (Ovens Valley and Kiewa Valley) of the Local Section of the Bright Planning Scheme by introducing specific controls for the rural residential development of Lot 2 Lodged Plan No. 220447 and Crown Allotment 2E, Section M, Parish of Bright.

The amendment can be inspected at Shire of Bright, Municipal Offices, Churchill Avenue, Bright; Department of Planning and Housing, The Olderfleet Buildings, 477 Collins Street, Melbourne; and at the Department of Planning and Housing, 1 McKoy Street, West Wodonga.

Submissions about the amendment must be sent to Shire of Bright, Municipal Offices, P.O. Box 139, Bright 3741: Attention: the Town Planner, by 29 July 1992.

Dated 17 June 1992

18837

R. M. SLAPP  
Town Planner  
Shire of Bright

SHIRE OF BUNGAREE  
Road Name

Notice is hereby given pursuant to the provisions of section 535 (4) of the *Local Government Act* 1958, that the Council of the Shire of Bungaree at its meeting of 1 June 1992 adopted without modification that road name as shown in hachure hereunder, hereafter called Orchard Lane.

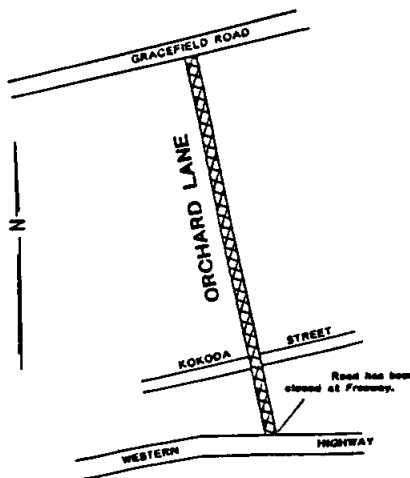

18863

B. C. REES  
Shire Secretary

1680 G 25 1 July 1992

SHIRE OF BULN BULN

Local Law No. 7

Temporary Dwellings

Notice is hereby given that the Council of the Shire of Buln Buln at its meeting held on Monday, 22 June 1992 made a Local Law pursuant to section 111 of the *Local Government Act 1989* and Regulation 58 of the *Victoria Building Regulations 1983* for the purposes of regulating and controlling the occupation of buildings used as Temporary Dwellings within the municipal district.

The general purport of the Local Law includes identification of the conditions which will apply to Permit Holders and penalties for non-compliance with such conditions.

Local Law No. 7 shall come into operation on 1 August 1992.

A copy of the Local Law is available for inspection or can be obtained at the prescribed fee from the Shire Office, 33 Young Street, Drouin, during office hours.

P. W. PHILLIPS

18850 Chief Executive/Shire Secretary

SHIRE OF COHUNA

Local Law No. 3

Streets and Roads

Notice is given that the Council of the Shire of Cohuna, at its ordinary meeting held on Monday, 18 May 1992, having considered submissions received pursuant to section 223 of the *Local Government Act 1989* resolved pursuant to section 119 of the Act to pass the Local Law known as the Shire of Cohuna Streets and Roads Local Law.

The purpose and general purport of Local Law No. 3 includes:

To Control and Manage Traffic, Use of Roads by Persons, Vehicles and Animals.

To Regulate Parking.

A copy of Local Law No. 3 of the Shire of Cohuna is available for inspection during office hours: (8 a.m. to 4.45 p.m.) at the Shire Offices, King Edward Street, Cohuna 3568.

P. TONKIN

18891 Acting Shire Secretary

SHIRE OF COHUNA

Local Law No. 4

Municipal Places

Notice is hereby given that the Council of the Shire of Cohuna, at its ordinary meeting held on Monday 18 May 1992, having considered

*Victoria Government Gazette*

submissions received pursuant to section 223 of the *Local Government Act 1989* resolved pursuant to section 119 of the Act to pass the Local Law known as the Shire of Cohuna Municipal Places Local Law.

The purpose and general purport of Local Law No. 4 includes:

To Allow and Protect the Quiet Enjoyment of People of Municipal Places.

To Protect Council and Community Assets and Facilities.

A copy of Local Law No. 4 of the Shire of Cohuna is available for inspection during office hours: (8 a.m. to 4.45 p.m.) at the Shire Offices, King Edward Street, Cohuna 3568.

P. TONKIN

18892 Acting Shire Secretary

SHIRE OF EUROA

The Council of the Shire of Euroa gives notice that it proposes to make Local Law No. 3 for the purpose of regulating its meeting procedures.

Any person affected by the proposed local law may make a written submission to the Council in accordance with section 223 of the *Local Government Act 1989*.

Any such submission received within fourteen days after the publication of this notice will be considered by Council at its meeting of 20 July 1992. Any person lodging a submission may request to be heard personally in support of their submission.

A copy of the proposed local law can be obtained from the Council office in Binney Street, Euroa, during normal office hours.

18866

SHIRE OF EUROA

The Council of the Shire of Euroa gives notice that it proposes to make Local Law No. 4 for the purpose of regulating its library services.

Any person affected by the proposed local law may make a written submission to the Council in accordance with section 223 of the *Local Government Act 1989*.

Any such submission received within fourteen days after the publication of this notice will be considered by Council at its meeting of 20 July 1992. Any person lodging a submission may request to be heard personally in support of their submission.



A copy of the proposed local law can be obtained from the Council office in Binney Street, Euroa, during normal office hours.

18867

*Planning and Environment Act 1987*

SHIRE OF HASTINGS

Notice of Amendment to a Planning Scheme  
Amendment L61

The Shire of Hastings has prepared Amendment L61 to the Hastings Planning Scheme.

The amendment affects land at 111, 113, 115, 116, 118, 119, 122, 123, 124 and 130 High Street, Hastings; 2, 4, 6 and 8 Albert Street, Hastings; 33, 35, 37 and 39 Church Street, Hastings; and 32, 40, 42 and 44 Victoria Street, Hastings.

The amendment proposes to change the Planning Scheme by rezoning the land from Residential 1 and Residential 2 to a proposed new zone, Service Business 1 (Consulting Services).

The proposed new zone will encourage a range of office and professional consulting uses to be established in high profile locations and in proximity to the Hastings Bush Nursing Hospital, and commercial and car parking areas. Shop and supermarket uses will be prohibited.

The amendment can be inspected at the Shire Offices, Marine Parade, Hastings; the Department of Planning and Housing, 33-39 High Street, Cranbourne; and the Department of Planning and Housing, The Olderfleet Buildings, 477 Collins Street, Melbourne.

Submissions about the amendment must be sent to the Manager, Planning and Development, Shire of Hastings, PO Box 55, Hastings 3915 by 3 August 1992.

18886 W. R. FEATHERSTON  
Chief Executive Officer

*Planning and Environment Act 1987*

SHIRE OF HASTINGS

Notice of Amendment to a Planning Scheme  
Amendment L62

The Shire of Hastings has prepared Amendment L62 to the Hastings Planning Scheme.

The amendment affects land at 143, 145, 147, 184 and 192 Salmon Street, Hastings; 6, 8, 10, 12 and 16 High Street, Hastings; 27 Marine Parade, Hastings.

The amendment proposes to change the Planning Scheme by rezoning the land from District Business to a proposed new zone, Service Business (Tourist and Commercial).

The proposed new zone will encourage the establishment of a range of tourist, office and related commercial activities which are complementary to the Hastings Town Centre and Hastings foreshore. Shop and supermarket uses will be prohibited.

The amendment can be inspected at the Shire Offices, Marine Parade, Hastings; the Department of Planning and Housing, 33-39 High Street, Cranbourne; and the Department of Planning and Housing, The Olderfleet Buildings, 477 Collins Street, Melbourne.

Submissions about the amendment must be sent to the Manager, Planning and Development, Shire of Hastings, PO Box 55, Hastings 3915 by 3 August 1992.

18887 W. R. FEATHERSTON  
Chief Executive Officer

*Planning and Environment Act 1987*

SHIRE OF HASTINGS

Notice of Amendment to a Planning Scheme  
Amendment L63

The Shire of Hastings has prepared Amendment L63 to the Hastings Planning Scheme.

The amendment affects land at 768-810 (inclusive) Frankston-Flinders Road and the front part of 812 and 814 Frankston-Flinders Road, Hastings. This land is generally between Pound Road and High Street, on the west side of Frankston-Flinders Road, Hastings.

The amendment proposes to change the Hastings Planning Scheme by rezoning the land from Residential 2 and Public Purposes—Existing 1c (Municipal-Other) to Low Intensity Commercial Zone.

The amendment can be inspected at the Shire Offices, Marine Parade, Hastings; the Department of Planning and Housing, 33-39 High Street, Cranbourne; and the Department of Planning and Housing, The Olderfleet Buildings, 477 Collins Street, Melbourne.

Submissions about the amendment must be sent to the Manager, Planning and Development, Shire of Hastings, PO Box 55, Hastings 3915 by 3 August 1992.

18888 W. R. FEATHERSTON  
Chief Executive Officer

1682 G 25 1 July 1992

*Planning and Environment Act 1987*  
KYNETON PLANNING SCHEME  
Notice of Amendment to a Planning Scheme  
Amendment L2

The Rural Water Commission has prepared Amendment L2 to the Local Section of the Kyneton Planning Scheme.

The amendment affects rural land around the perimeter of the Upper Coliban Reservoir which is to be acquired by the Rural Water Commission to accommodate an increase in water level in the Reservoir.

The amendment proposes to change the planning scheme to reserve rural land for Proposed Water Storage (Rural Water Commission) to enable the Commission to acquire the land.

The amendment can be inspected at the Shire Offices, Shire of Kyneton, 129 Mollison Street, Kyneton; the Department of Planning and Housing, 477 Collins Street, Melbourne; the Loddon-Campaspe Regional Planning Authority, 261 Hargreaves Street, Bendigo and the Coliban-Campaspe Regional Office of the Rural Water Commission, Alder Street, Golden Square.

Submissions about the amendment must be sent to the Manager, Planning and Technical Services, Rural Water Commission, Alder Street, Golden Square 3555 by 5 August 1992.  
Dated 26 June 1992

18920 K. E. BRIGGS  
Regional Manager

SHIRE OF KYNETON  
Appointment of Poundkeeper

Advice is given that Council by resolution of 17 June 1992 has appointed William L. Grady as Poundkeeper under the provisions of the *Pounds Act 1958* to replace Gerard Gallagher.

18864 GRAEME J. WILSON  
Chief Executive Officer

*Planning and Environment Act 1987*  
SHIRE OF MILDURA

Notice of Amendment to a Planning Scheme  
The Shire of Mildura has prepared Amendment No. L31 to the Mildura Shire Planning Scheme.

The amendment affects land situated on the East side of the Calder Highway, Yelta, described as Crown Allotment 36 in the Parish of Yelta.

*Victoria Government Gazette*

The amendment proposes to change the Planning Scheme by allowing for a two lot subdivision otherwise not permitted under the Scheme.

The amendment can be inspected at the Shire of Mildura Municipal Offices, Fifteenth Street, Irymple, Victoria; Department of Planning and Housing, 477 Collins Street, Melbourne; Department of Planning and Housing, 261 Hargreaves Street, Bendigo, Victoria.

Submissions about the amendment must be sent to Shire of Mildura Municipal Offices, PO Box 366, Irymple, Victoria 3498 by 3 August 1992.

18907 H. D. KIRBY  
Shire Engineer

SHIRE OF SHERBROOKE  
Miscellaneous Local Law No. 8

Notice is given that at a meeting of the Council of the Shire of Sherbrooke held on 23 June, 1992, the Council resolved to make a Local Law entitled "Local Law No. 8—Miscellaneous Local Law" pursuant to the provisions of the *Local Government Act 1989* and the *Health Act 1958*.

The purposes and general purport of the Local Law are:

1. To regulate public open space reserves and other lands under the management or control of the Council.
2. To regulate the construction of footpath and channel crossings and works in roads.
3. To regulate public behaviour and the use of trolleys and toy vehicles in public places; to regulate the soliciting of gifts; the control of flora adjacent to roads; the control of weeds; obstruction of roads; unsightly premises.
4. Controlling street stalls and hawking.
5. Making provision for numbering properties in the streets.
6. Fixing fees for permits and prescribing the purposes for which and conditions on which the Council may grant permits and the manner in which permits should be applied for.
7. Provisions for enforcement of the Local Law including infringement notices and penalties for its breach.

8. Providing for the peace and order and good government of the municipal district of the Shire.

The Local Law will come into operation on the date of this publication, 1 July 1992.

A copy of the Local Law may be inspected or purchased from the Administration Section at the Shire Offices, 351 Glenfern Road, Upwey, 3158, during normal office hours (8.30 a.m. to 5.00 p.m. Monday, and Wednesday to Friday, 8.30 a.m. to 8.00 p.m., Tuesday).

18910 BOB SEIFFERT  
Chief Executive Officer

*Planning and Environment Act 1987*

TAMBO PLANNING SCHEME

Notice of Amendment to a Planning Scheme  
Amendment L52

The Shire of Tambo has prepared Amendment L52 to the Tambo Planning Scheme, Local Section Chapter 1, Lakes Entrance.

The amendment affects land at Crown Allotment 31D Parish of Colquhoun and previously known as Harbeck Street together with a portion of land being part of Lot 3 LP 219775, Colquhoun Road, Lakes Entrance, having an area of approximately 1.092 hectares.

The amendment proposes to change the Planning Scheme by rezoning the abovementioned subject land from Rural to Public Purposes—Cemetery under the Tambo Planning Scheme, Local Section Chapter 1, Lakes Entrance.

The amendment can be inspected at Shire of Tambo, Civic Centre Offices, 55 Palmers Road, Lakes Entrance; Inspection Office, Department of Planning and Housing, Ground Floor, 477 Collins Street, Melbourne; Regional Office Gippsland, Department of Planning and Housing, 11 Hazelwood Road, Morwell 3840.

Submissions about the amendment must be sent to the Chief Executive, Shire of Tambo, PO Box 80, Lakes Entrance 3909 and should state whether you wish to be heard in respect of the submission by 3 August 1992.

18868 G. R. HILL  
Acting Chief Executive

SHIRE OF TULLAROOP

Local Law No. 2

Notice is hereby given that the Council of the Shire of Tullaroop, at a meeting scheduled to be held on Tuesday, 11 August 1992, proposes pursuant to the provisions of Part 5 of the *Local Government Act 1989*, to make Local Law No. 2 which will cover the following matters—

Part 1—Preliminary.

Part 2—Repeal and Replacement of Clause 940 of 'Local Laws of the Shire of Tullaroop' thereby clarifying the application of those provisions of the said Local Law which relate to recreation vehicles.

A copy of Local Law No. 2 is available at the Shire Office, Maryborough 3465.

Any person affected by the proposed Local Law may make a written submission to the Council within 14 days of publication of this notice in accordance with section 223 (1) of the *Local Government Act 1989*.

Any person making a submission to the Council may request that he or she be heard in support of the written submission and is entitled to appear in person or by a person appointed on his/her behalf before the meeting of Council.

Submissions should be addressed to the Shire Secretary, Shire of Tullaroop, Neil Street, Maryborough 3465.

18848 BRIAN F. O'CONNOR  
Shire Secretary

SHIRE OF WARRACKNABEAL

Local Law No. 5

Library and Community Information Local Law

Notice is hereby given that the Council of the Shire of Warracknabeal at its Ordinary Meeting held on Friday, 19 June 1992 made and passed a local law titled "Local Law No.5", pursuant to the provisions of the *Local Government Act 1989*, to:

Regulate access and conduct of users of the library service.

Provide membership criteria and responsibilities.

Define the rights and obligations of members of the library.

A copy of Local Law No. 5 is available at the Shire Offices, Scott Street, Warracknabeal during office hours.

18895 K. V. SHADE  
Shire Secretary

1684 G 25 1 July 1992

**SHIRE OF UPPER YARRA**  
Naming of Laneway

Notice is hereby given that in pursuance of the powers conferred by the *Local Government Act 1958*, the Shire of Upper Yarra at a meeting held on 16 June 1992 resolved to name the laneway shown in the diagram below to Warren Lane, Yarra Junction.

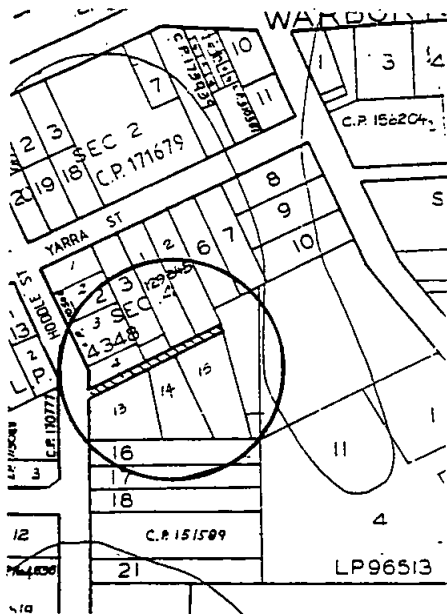

The name will take effect as from Wednesday, 1 July 1992.

18902 **A. J. HUBBARD**  
Chief Executive Officer

*Victoria Government Gazette*

general order of business, rules of debate, procedure, public access, conduct at meetings, procedure for the election of Shire President, use and safekeeping of the Council's Common Seal, and penalties for non-compliance with such laws as they relate to such meetings and procedures.

If made, the Local Law also will replace and repeal the existing Proceedings of Council By-law, By-law No. 71.

A copy of the proposed Local Law can be obtained from the Council Office at 99 Fairy Street, Warrnambool.

Any person affected by the proposed Local Law may make a submission relating to it to Council. Submissions received by the Council within 14 days of the publication of this notice will be considered by the Council in accordance with section 223 of the *Local Government Act 1989*. Any person requesting that she or he be heard in support of the written submission is entitled to appear before a meeting of the Council either personally or by a person acting on her or his behalf and will be notified of the time and date of the hearing.

18882 **G. D. PRICE**  
Shire Secretary

*Police Regulation Act 1958, Section 122*  
**SALE OF UNCLAIMED AND  
CONFISCATED PROPERTY**

Auction of unclaimed and confiscated property held by Police will be conducted at the Auction Rooms of the Sheriff's Southern Regional Headquarters, 8-20 King Street, Oakleigh commencing from 11.00 a.m. on 9 July 1992.

18927 **K. GLARE**  
Chief Commissioner

**SHIRE OF WARRNAMBOOL**  
Notice of Proposed Local Law  
Local Law No. 1

The Shire of Warrnambool proposes to make a Local Law for the purposes of regulating:

1. Proceedings at meetings of Council and Committees;
2. The election of Shire President; and
3. The use of the Council Common Seal.

The general purport of the proposal includes a specification of the laws which will govern the

**TAMBO WATER BOARD**  
Extension of Sewerage District

Notice is hereby given that it is the intention of the Tambo Water Board to extend its Sewerage District so as to encompass the township of Lake Tyers Beach as shown edged on Plan TWB LTB01. A copy of the plan is available for perusal at the Board Office, 55 Palmers Road, Lakes Entrance.

18865 **W. J. HOBSON**  
Chief Executive

Victoria Government Gazette

WESTERNPORT WATER BOARD  
Newhaven Sewerage District  
General Notice

Notice is hereby given that the Westernport Water Board has made provisions for carrying off the sewage from each and every property which, or any part of which, is within the sewerage area hereinafter described in accordance with section 144 of the *Water Act* 1989.

Each and every property described within the said sewerage area shall be declared a serviced (sewered) property on and after 1 July 1992.

The boundaries of the sewerage area herein before referred to are:

Commencing at Westernport Bay at the low water mark directly north of the western boundary of Lot 1 LP 122015 Boys Home Road, then proceeding south to the eastern boundary of CA 27, 158th Phillip Island Road, then east to the western boundary of Lot 1 LP 110352 Phillip Island Road, then south to the western boundary of CP 160569 Boys Home Road, then east to the western boundary of Lot 10 LP 17839 Beach Crescent, then south easterly to the north western boundary of Lots 1-3 LP 66518 Beach Crescent then south to the low water mark of Westernport Bay and following the low water mark of Westernport Bay generally proceeding in a northerly and westerly direction back to the low water mark directly north of the western boundary of Lot 1 LP 122015 Boys Home Road.

A copy of the notice and plan of the area described above is available for inspection at the Board Offices, Thompson Avenue, Cowes.

This notice shall exclude the following specific property:

3.30.100 40-42 Boys Home Road,  
Newhaven (Lot 3 LP 122015).

P. VAN HAMOND  
18942 Acting Assistant Secretary

DELEGATION OF AUTHORITY  
Under the *Freedom of Information Act* 1982  
(Section 26)

Small Business Development Corporation

The officer occupying for the time being (whether on a permanent, acting or temporary basis), the position of Manager, Metropolitan Business Advisors in the Small Business Development Corporation, is authorised to make all necessary decisions on behalf of the Corporation, in order to comply with and give

G 25 1 July 1992 1685

effect to the provisions of the Freedom of Information Act in respect of requests made to the Corporation. Any previous notice of authorisation of this position is hereby revoked.  
Dated 29 March 1992

JIM WEBBER  
General Manager  
18914 Small Business Development Corporation

DELEGATION OF AUTHORITY  
Under the *Freedom of Information Act* 1982  
(Section 26)

Department of Small Business

The officer occupying for the time being (whether on a permanent, acting or temporary basis), the position of Manager, Metropolitan Business Advisors in the Small Business Development Corporation, is authorised to make all necessary decisions on behalf of the Department, in order to comply with and give effect to the provisions of the Freedom of Information Act in respect of requests made to the Department. Any previous notice of authorisation of this position is hereby revoked.  
Dated 29 March 1992

JIM STEVENSON  
Director-General  
18915 Department of Small Business

Notice is hereby given that the partnership between Catherine Mary Branigan of Benalla, Vincent Michael Branigan of 86 Stawell Street, Echuca and Eileen Joan Maher of Simpson Street, Oxley carried on near Benalla, Victoria under the name and style "The Branigan Family Farm" was dissolved on 16 April 1992. 18893

Take notice that the partnership heretofore existing between Nabiha Haidamous and Georgette Brown, carrying on business as 5 Star Child Care at 79 Gladstone Road, Dandenong has been dissolved as at 13 March 1992.

ALAN ROTMAN AND ASSOCIATES, 423  
South Road, Moorabbin 18896

I, Robin Anthony Taranto, hereby advise that as from 30 June 1992 I will no longer be responsible for any debts incurred in my name in relation to Hilly Australia Pty. Ltd.

18916 ROBIN TARANTO

1686 G 25 1 July 1992

**NOTICE OF DISSOLUTION OF  
PARTNERSHIP**

Notice is hereby given that the partnership heretofore subsisting between George Nicholas Freijah, Shane Andrew Eales and Peter George Watach carrying on business as furniture and floor covering retailers at 184-192 Pakington Street, Geelong West under the style or form of Freijah Furniture has been dissolved as from 18 October 1991 so far as concerns the said Shane Andrew Eales who has retired from the said firm.

Dated 17 June 1992

**GEORGE NICHOLAS FREIJAH  
18846 PETER GEORGE WATACH**

Notice is hereby given that the partnership previously subsisting between Patrick Bentivoglio of 7 Thompson Street, Avondale Heights and Frank Dieni of 12 Harrington Road, Airport West carrying on business as entertainment proprietors at First Floor, 13 Puckle Street, Moonee Ponds under the style or firm name of "Moonee Ponds Billiards" has been dissolved as from 30 March 1992 so far as concern Frank Dieni who retires from the said firm.

**P. BENTIVOGLIO  
18847 F. DIENI**

Notice of application relating to **STEAL STOPPER SECURITY SYSTEMS AUSTRALIA PTY. LIMITED** (ACN 007 283 632) in respect of proceedings No. S3033 of 1992

Notice is given that an application will be made by Cornick Pty. Ltd. (ACN 001 621 610) trading as Electron Alarm Supplies to the Supreme Court of New South Wales, Queens Square, Sydney at 11.00 a.m. on 3 July 1992 for an order that the company be wound up.

Copies of documents filed may be obtained under the Rules.

Any person intending to appear at the hearing must serve a notice in the prescribed form so as to reach the address below no later than 9 a.m. on 2 July 1992.

**BRENTON CHRISTOPHER HALLIGAN  
Roach & Halligan, solicitors, 135 King  
Street, Sydney, NSW 18840**

*Victoria Government Gazette*

Notice of application relating to **CARTER MEROLLI AUSTRALIA PTY. LIMITED** (ACN 005 527 015) in respect of proceedings No. S1386 of 1992

Notice is given that an application will be made by Christopher Peter Abraham to the Supreme Court of New South Wales, Queens Square, Sydney at 10.00 a.m. on 22 June 1992 for an order that the company be wound up.

Copies of documents filed may be obtained under the Rules.

Any person intending to appear at the hearing must serve a notice in the prescribed form so as to reach the address below no later than 9 a.m. on 19 June 1992.

**BRENTON CHRISTOPHER HALLIGAN  
Roach & Halligan, solicitors, 135 King  
Street, Sydney, NSW 18839**

**Corporations Law  
FISHER SWAN PTY. LTD.  
(In Liquidation)  
ACN 004 336 010  
Notice of Voluntary Liquidation  
Section 491 (2)**

At an extraordinary meeting of the members of the abovementioned company, duly convened and held at the offices of Digby Kellam McKenzie, 10th Floor, 3 Bowen Crescent, Melbourne on 26 June 1992, the following Special Resolution was passed:

That the company be wound up as a Members Voluntary Liquidation and that the assets of the company be distributed in whole or in part to the members in specie should be liquidator so desire.

Dated 26 June 1992

**JOHN W. MCKENZIE  
Digby Kellam McKenzie, 10th Floor, 3  
Bowen Crescent, Melbourne 18901**

**MOE DISTRICT CREDIT UNION  
CO-OPERATIVE LIMITED  
(In Liquidation)**

I, Anthony George Hodgson, of Ferrier Hodgson & Co., chartered accountants, 459 Collins Street, Melbourne, hereby give notice that I ceased to act as liquidator of Moe District Credit Union Co-operative Limited on 5 June 1992.

**18923 A. G. HODGSON**

## Unclaimed Moneys Act 1962

## Register of Unclaimed Moneys held by the—

<i>Name of Owner on Books and Last Known Address</i>	<i>Total Amount Due to Owner</i>	<i>Description of Unclaimed Money</i>	<i>Date when first became Payable</i>
\$			
PARBURY LIMITED			
A C Parkin & Co Pty Ltd, 60 Alfred St, Kew	189.32	Dividend	18.5.90
Avery, Julliet A, 12 Denbigh Rd, Armadale	91.20	"	"
Curry, Paul C, 13 Barber Rd, Ferny Hills, Qld	30.82	"	"
Hancam Pty Ltd, PO Box 612, Willoughby, NSW	250.00	"	"
Hughes, Oriel G, 63 Mareeba Rd, Ashgrove, Qld	25.00	"	"
J L Brown & Co Pty Ltd, 403A St Kilda Rd, Melbourne	39.92	"	"
Kingsley, Frederic A, 10 Thurloe St, London, UK	50.00	"	"
Leong, Keow T, 78 Jalan Batu Tiga, Klang 41300, Selangor, Malaysia	20.00	"	"
Rogers, Patricia, 16 Raheen Dve, Kew	50.00	"	"
Romer, Robert M, Sion Lodge, 34 Sion Hill, Bath Avon, UK	267.12	"	"
Shurey, Robert J, 9 Madigan Dve, Glen Waverley	21.66	"	"
Stokes, Thomas A, c/o 15 Sorrett Ave, Malvern	15.82	"	"
Grasis, Ivan, PO Box 605, Mascot, NSW	50.00	"	15.8.90
Mellor, Donald H, 17 Albert St, East Melbourne	50.00	"	"
Richards, Claire H, 2 Kelvin Gve, East Prahran	500.00	"	15.2.90
1019			
BYRON HOLDINGS LIMITED			
Anderson, Carolyn, 10/36 Grange Rd, Toorak	25.00	Cheque	10.5.89
Anthony Kongats & Associates Pty Ltd, 85 Probert St, Newtown, NSW	65.00	"	"
Chateau Textiles Pty Ltd (A/C Chatex No. 2 Super Fund), Unit 4, 37 Foley St, Kew	40.00	"	13.10.89
Drysdale, Kirsteen, 21/76 Great Western Hwy, Parramatta, NSW	195.00	"	10.5.89
Levesconte, Michael W, GPO Box 748, Sydney, NSW	40.00	"	13.10.89
Ridden, Jennifer, 8/2 Avona Ave, Glebe, NSW	83.85	"	10.5.89
Stevens, Mark, 17 Malbara Cres, Belrose, NSW	60.00	"	13.10.89
Wylie, John, 9 Passey Ave, Hunters Hill, NSW	70.23	"	10.5.89
1002			
ATLAS STEELS LIMITED			
Ardzejewska, Maria and Irene, 174 Stephen St, Blacktown, NSW	12.50	Cheque	22.9.89
Batson, Benjamin A, 12 Jalan Kelabu ASAP, Singapore	35.00	"	"
Brook, Trudi, 8 Roe St, North Bondi	25.00	"	"
Chelsea Styles Pty Ltd, 16th Floor, 109 Pitt St, Sydney, NSW	625.00	"	"
Chessell, Leo J (A/C Syscorp Super Trust), 41 Military Rd, Neutral Bay, NSW	212.50	"	"
Jarman, Jennifer E, 21 Barrington Ave, Kew	50.00	"	"
Reid, Mervyll, c/o Duke Securities Ltd, 1 Collins St, Melbourne	50.00	"	"
Vanjour, Lorna and Ian, 35 Woodburn Rd, Berala, NSW	25.00	"	"
Whitford, Cheryl A, 386 South Rd, Richmond, SA	12.50	"	"
1000			
AUSTRALIAN COMMERCIAL PROPERTY TRUST			
McGhee, Nola, 13 Gledden St, Chifley, ACT	83.16	Cheque	31.8.89
1001			

## Unclaimed Moneys Act 1962

## Register of Unclaimed Moneys held by the—

Name of Owner on Books and Last Known Address	Total Amount Due to Owner	Description of Unclaimed Money	Date when Amount first became Payable
\$			
C. J. KEANE & CO			
Stewart, Yvonne, 3/14 Osbourne Ave, North Geelong	300.00	Bond	24.5.90
Ferrier, P, 12 King St, Queenscliff	78.99	Rent	22.6.90
Biressa Pty Ltd, 23 St Leonards Rd, Ascot Vale	111.24	..	26.6.90

1078

MOE DISTRICT CREDIT UNION  
CO-OPERATIVE LIMITED  
(In Liquidation)

I, Anthony D'Aloia, of Ferrier Hodgson & Co., chartered accountants, 459 Collins Street, Melbourne, hereby give notice that pursuant to section 192 (6) of the *Co-operation Act* 1981, I was appointed liquidator of Moe District Credit Union Co-operative Limited on 5 June 1992.

A. D'ALLOIA  
Liquidator

18922

CORPORATIONS LAW  
Section 195  
Companies and Securities Rules 1985  
PTB FINANCE PTY. LTD.  
A.C.N. 006 924 385  
Reduction of Capital

Notice Pursuant to Rule 6.21 (b)

On 26 June 1992, upon application to the Supreme Court of Victoria by PTB Finance Pty. Ltd., the Court did order that the reduction of share capital proposed to be effected by the implementation of the Special Resolution of PTB Finance Pty. Ltd. ("the Company") which was duly passed at a meeting of the members of the Company on 5 June 1992, as follows:

AS A SPECIAL RESOLUTION

That the capital of the Company be reduced—  
From \$10 000 000 divided into 10 000 000 ordinary shares of \$1.00 each of which 6 854 693 are issued and fully paid.

To \$3 175 310 divided into 3 175 310 ordinary shares of \$1.00 each of which 30 003 are issued and fully paid.

By—

- (a) cancelling 2 274 896 ordinary shares of \$1.00 each held by G. & E. T. Nominees Pty. Ltd., 2 274 897 ordinary shares of \$1.00 each held by Gavanpound Pty. Ltd. and 2 274 897 ordinary shares of \$1.00 held by Negril Pty. Ltd. comprising part of the issued capital of the Company; and
- (b) distributing \$1 045 792 to G. & E. T. Nominees Pty. Ltd.; and
- (c) distributing \$1 045 792 to Gavanpound Pty. Ltd.; and
- (d) distributing \$1 045 792 to Negril Pty. Ltd.; and
- (e) crediting the at call loan account of Negril Pty. Ltd. in the books of the Company with \$1 229 104; and
- (f) crediting the at call loan account of G. & E. T. Nominees Pty. Ltd. in the books of the Company with \$1 229 105; and
- (g) crediting the at call loan account of Gavanpound Pty. Ltd. in the books of the Company with \$1 229 105.

be confirmed.

Dated 29 June 1992

18913

PIERRE RALPH BERNARDI  
Director

Notice is hereby given in accordance with section 491 (2) of the *Corporation Act* 1989 that at an extraordinary general meeting of the members of Jenoura Hotels Pty. Limited (In Liquidation) A.C.N. 004 544 754 held of 22 June 1992, the following Special and Ordinary Resolutions were respectively duly passed:



*Victoria Government Gazette*

That the company be wound up voluntarily and Arthur Eady, chartered accountant of Level 6, 131 Clarence Street, Sydney, be appointed liquidator for the purpose of such winding up.

Dated 24 June 1992

18898

ARTHUR EADY  
Liquidator

In the Supreme Court of Victoria at Melbourne—No. 7818 of 1992—In the matter of the Corporations Law; and in the matter of Reservoir Donvale Combine Pty. Ltd., A.C.N. 005 927 471—Advertisement of application for winding-up

Notice is hereby given that an application for the winding up of the abovenamed company by the Supreme Court of Victoria was on 19 June 1992 filed by Building Product Supplies Pty. Ltd., A.C.N. 006 150 036. The application is to be heard before the court in the 7th Court Law Courts, Lonsdale Street, Melbourne at 10.30 a.m. on 7 August 1992.

The liquidator whose appointment is sought is Dennis John Cogle of the firm Bent and Cogle Bentleys, First Floor, 480 St Kilda Road, Melbourne.

Any creditor or contributory of the company desiring to support or oppose the making of an order on the application may appear at the time of the hearing by himself or his counsel for that purpose. A copy of the application will be furnished by the undersigned to any creditor or contributory of the company requiring it on payment of the regulated charge.

The applicant's address is 750 Lorimer Street, Port Melbourne.

The applicant's solicitors are Carroll & Dillon, 3rd Floor, 90 William Street, Melbourne 3000.

*Note:* Any person who intends to appear on the hearing of the application must serve on or send by post to the above-named solicitors notice in writing of his intention so to do. The notice must state the name and address of the person, or if a firm, the name and address of the firm and must be signed by the person or firm, or his or their solicitor (if any), and must be served or, if posted, must be sent by post in sufficient time to be received not later than 4 o'clock in the afternoon of 6 August 1992.  
18941

G 25 1 July 1992 1689

THOMAS HOLM LARSEN, late of 11 Ozone Avenue, Mount Martha, Victoria, deceased

Creditors, next of kin and all other persons having claims against the estate of the said deceased are required by Robyn Lesley Johnston of Unit 4, 29 Edward Street, Hastings, Victoria, home duties the administratrix to send particulars of such claims to the undermentioned solicitors on or before 4 September 1992 after which date they will distribute the assets having regard only to those claims of which they then have notice.

SAM STIDSTON & CO., solicitors, Suite 4,  
307 Main Street, Mornington 18862

Creditors, next of kin and others having claims in respect of the estate of Marjorie Mary McCulloch, late of 7 Centre Road, East Brighton, widow, deceased, who died on 2 April 1992 and probate of whose will has been granted to Jack Stewart Brittingham of Crofts Road, Nar Nar Goon, retired are required to send particulars of their claims to the said executor care of the undermentioned solicitors by 1 September 1992 after which date he will distribute the assets having regard only to the claims of which he then has notice.

PEARCE & WEBSTER, solicitors, 51  
Queen Street, Melbourne 18873

Creditors, next of kin and others having claims in respect of the estate of Edith Blenkiron Rowe late of Unit 12, Yarrowonga Court, 12 William Street, South Yarra, spinster, deceased, who died on 29 January 1992, are to send particulars of their claims to The Equity Trustees Executors and Agency Co. Ltd. of 472 Bourke Street, Melbourne, by 5 September 1992, after which date it will distribute the assets having regard only to the claims of which it then has notice. 18924

Creditors, next of kin and others having claims in respect of the estate of George Russell Allmand late of Unit 2, 6 Turner Road, Highett, in the State of Victoria, retired pharmacist, deceased who died on 8 April 1992, are to send particulars of their claims to The Equity Trustees Executors and Agency Co. Ltd. of 472 Bourke Street, Melbourne by 8 September 1992, after which date it will distribute the assets having regard only to the claims of which it then has notice. 18925

1690 G 25 1 July 1992

Creditors, next of kin and others having claims in respect of the will of Amy Clara King, late of Alton Court, 30/2 McIntyre Drive, Altona, widow, deceased, who died on 26 May 1992, are requested to send particulars of their claims to the executor Lorna Darling care of the undermentioned solicitor by 8 September 1992, after which date she will distribute the assets having regard only as to the claims of which she then has notice.

JOHN STEWART, solicitor, of 290  
Racecourse Road, Newmarket 18897

Creditors, next of kin and others having claims in respect of the estate of Oscar Keith Pralle, late of 37 Radnor Street, Camberwell, retired, deceased, who died on 28 December 1991, are to send the particulars of their claims to The Equity Trustees Executors and Agency Company Limited and Roland Dousset at 472 Bourke Street, Melbourne, within two months of the publication of this notice, after which date they will distribute the assets having regard only to the claims of which they then have notice.

MESSRS. PEARCE & WEBSTER,  
solicitors, of 51 Queen Street, Melbourne 18899

Creditors, next of kin and others having claims in respect of the estate of Rendi-Leah Kent (also known as Rendi-Leah Mitchell), formerly of 253 Bay Street, North Brighton, but late of 37A Tucker Road, East Bentleigh in the State of Victoria are required to send particulars of claims to the executors John Henry James Mitchell and David Henry Sonenberg, care of the undermentioned solicitors, in the said State, on or before 15 September 1992, after which date the executors will distribute the estate having regard only to the claims of which they then have notice.

DAVID SONENBERG & ASSOCIATES,  
solicitors, 293 Bay Street, Brighton 18905

Creditors, next of kin and others having claims against the estate of John Leonard Harbeck late of Unit 54, Fountain Court Retirement Village, 100 Station Street, Burwood, Victoria, retired bank manager, deceased, who died on 10 February 1992, are requested to send particulars of their claims to ANZ Executors & Trustee Company Limited (A.C.N. 006 132 332) of 91 William Street, Melbourne, Victoria and Thoma Lorraine Harbeck of Unit 54, Fountain Court Retirement Village, 100 Station Street, Burwood, Victoria,

*Victoria Government Gazette*

the executors appointed by the will care of ANZ Executors & Trustee Company Limited (A.C.N. 006 132 332) of 91 William Street, Melbourne, Victoria by 1 September 1992, after which date they will distribute the assets of the estate having regard only to the claims of which they then have notice. 18934

Creditors, next of kin and others having claims in respect of the estate of Maurya Ortrude Deegan formerly of 49 Warwick Street, Ascot Vale, but late of Northwest Hospital, Poplar Road, Parkville, spinster, deceased, who died on 24 April 1992, are requested to send particulars of their claims to executor National Mutual Trustees Limited of 65 Southbank Boulevard, South Melbourne, formerly and in the will described as National Trustees Executors and Agency Company of Australasia Limited of 95 Queen Street, Melbourne, by 4 September 1992, after which date the executor will distribute the assets having regard only to the claims of which it then have notice.

PETER J. WALSH & JOHN F. CARROLL,  
solicitors, 83 William Street, Melbourne 18935

ALLAN GEORGE GRIFFIN, late of 398  
Albert Street, West Brunswick in the State of  
Victoria, butcher, deceased

Creditors, next of kin and others having claims in respect of the estate of the deceased (who died on 21 February 1992) are required by National Mutual Trustees Limited, of 65 Southbank Boulevard, South Melbourne, to send particulars of their claims to the said company by 1 September 1992, after which date it will convey or distribute the assets, having regard only to the claims of which the company then has notice.

DUNHILL MADDEN BUTLER, solicitors,  
575 Bourke Street, Melbourne 18931

Creditors, next of kin and others having claims in respect of the estate of Veronika Gaszner, late of 17 Seaview Road, Frankston, retired, deceased, who died on 18 March 1992, are required to send particulars of their claims to the executor, Giuseppe Biviano of 17 Seaview Road, Frankston, on or before 1 September 1992, after which date he will distribute the assets having regard only to the claims of which he then had notice.

WHITE CLELAND PTY., solicitors, 108  
Young Street, Frankston 18932

*Victoria Government Gazette*

G 25 1 July 1992 1691

WILLIAM BIRKS HAWSON, late of Unit 16, Rosebud Retirement Village, Bayview Road, Rosebud in the State of Victoria, gentleman, deceased

Creditors, next of kin and others having claims in respect of the estate of the deceased who died on 20 December 1991 are required by Trust Company of Australia Limited of 151 Rathdowne Street, Carlton South to send particulars of their claim to the said company by 2 September 1992 after which date it will convey or distribute the assets having regard only to the claims of which the Company then has notice.

McKAY WILLIS, solicitors of 25 North Concourse, Beaumaris 18838

WALTER KARPISH, late of 161 Police Road, Mulgrave, gentleman, deceased

Creditors, next of kin and others having claims in the estate of the abovenamed deceased who died on 22 March 1991 are required prior to the expiration of three calendar months from the date of publication of this notice to send particulars of such claims to the administratrix of the deceased's estate, Larissa Karpish care of the undersigned, after the expiration of which period the assets of the estate will be distributed by the administratrix having regard only for those claims of which she shall then have notice.

JOHN BURGESS & CO., 257 Springvale Road, Springvale, solicitors for the applicant 18841

GERTRUDE ELLEN TREGENZA, late of 22 Hedge End Road, Mitcham in the State of Victoria, widow, deceased

Creditors, next of kin and others having claims in respect to the estate of the deceased (who died on 3 May 1992) are required by the executor Francis Wooton Hooper of 22 Hedge End Road, Mitcham, head gardener, to send particulars to him, care of the undersigned, on or before 15 September 1992 after which date he will distribute the assets having regard only to the claims of which he then has notice.

BAYLOR & CO., solicitors, 1 Walkers Road, Nunawading 18842

Creditors, next of kin and others having claims in respect of the estate of Harold James Turner, late of 19 Kananook Avenue, Seaford, retired, deceased who died on 5 March 1992, are required to send particulars of their claims to the

ANZ Executors & Trustees Company Limited (A.C.N. 006 132 332) of 91 William Street, Melbourne on or before 1 September 1992, after which date it will distribute the assets having regard only to the claims of which it then has notice.

WHITE CLELAND PTY., solicitors, 108 Young Street, Frankston 18926

Creditors, next of kin and others having claims in respect of the estate of Herbert Morice Head, late of 9 St Georges Grove, Parkville in the State of Victoria, retired, deceased, who died on 22 February 1992, are required to send particulars of the claims to the executor National Mutual Trustees Limited of 65 Southbank Boulevard, South Melbourne in the said State, on or before 2 September 1992, after which date the executor will distribute the estate having regard only to the claims of which it then has notice. 18928

Creditors, next of kin and others having claims in respect of the estate of Kathleen Frieda Browning, late of Unit 5, 39 Park Lane, Somerville in the State of Victoria, married woman, deceased who died on 15 December 1991, are required to send particulars of the claims to the executor National Mutual Trustees Limited of 65 Southbank Boulevard, South Melbourne in the said State, on or before 2 September 1992, after which date the executor will distribute the estate having regard only to the claims of which it then has notice. 18929

CHARLES JAMES MURPHY, late of Flat 1, 39 Mary Street, Hawthorn, Victoria, retired, deceased

Creditors, next of kin and others having claims in respect of the estate of the abovenamed deceased (who died on 14 March 1992) are required by the executor The Equity Trustees Executors and Agency Company Limited of 472 Bourke Street, Melbourne, to send particulars to the executor by 31 August 1992, after which date the executor may convey or distribute the assets having regard only to the claims of which it then has notice.

M. V. FERN & ASSOCIATES, solicitors, 6/532 Hampton Street, Hampton 18930

1692 G 25 1 July 1992

LESLIE DON FISHLEY, late of 182 Wattle Street, Bendigo, retired, deceased

Creditors, next of kin and others having claims in respect of the estate of the abovenamed deceased who died on 30 March 1992 are required by the executor National Mutual Trustees Limited of 46 Queen Street, Bendigo to send particulars to it at 46 Queen Street, Bendigo by 4 September 1992 after which date it may distribute the assets having regard only to the claims of which it then has notice.

COHEN KIRBY & ISER, solicitors, 94 Pall Mall, Bendigo 18849

LEDA TERESA CICCARELLI, late of 11 Mitchell Street, Bentleigh in the State of Victoria, retired teacher, deceased

Creditors, next of kin and others having claims in respect of the estate of the deceased, who died on 28 November 1991 are required by the trustee Geoffrey Alexander Fox of 112 Patterson Road, Moorabbin in the said State, solicitor to send particulars to him by 10 September 1992 after which date the trustee may convey or distribute the assets, having regard only to the claims of which he then has notice.  
Dated 1 July 1992

GEOFFREY A. FOX & ASSOCIATES, barristers and solicitors, 112 Patterson Road, Moorabbin 18851

PHYLLIS NORA JONES, late of Templestowe Private Hospital, 50 Foote Street, Templestowe, widow, deceased

Creditors, next of kin and others having claims in respect of the estate of the deceased who died on 3 July 1991 are required by the trustee Ian Geoffrey DeLacy of 2 Jennings Street, Kyneton, solicitor to send particulars to him by 2 September 1992 after which date the trustee may convey or distribute the assets having regard only to the claims of which he then has notice.

Dated 19 June 1992

ARMSTRONG, COLLINS AND DELACY, 2 Jennings Street, Kyneton, solicitors for the said trustee 18860

FRED GEORGE EAST, late of Mirridong Home for the Blind, Mclvor Road, Bendigo in the State of Victoria, gentleman, deceased

Creditors, next of kin and others having claims in respect of the estate of the deceased who died on 17 February 1992, and probate of

Victoria Government Gazette

whose will was granted by the Supreme Court of Victoria on 19 June 1992 to National Mutual Trustees Limited of 46 Queen Street, Bendigo in the said State and Jessie Carnegie Burnett of 59 Forest Street, Bendigo in the said State of Victoria, retired, are required by the abovenamed Trustees to send particulars to National Mutual Trustees Limited aforesaid by 26 August 1992, after which date the Trustees may convey or distribute the assets, having regard only to the claims of which they then have notice.

PETERSEN WESTBROOK & ASSOCIATES, solicitors, of 121 McCrae Street, Bendigo 18881

DORIS ISABELLA McLAINE, late of Falloons Road, Woodend, widow, deceased

Creditors, next of kin and others having claims in respect of the estate of the deceased who died on 28 January 1991, are required by the Trustee Ian Geoffrey DeLacy of 2 Jennings Street, Kyneton Solicitor to send particulars to him by 2 September 1992, after which date the Trustee may convey or distribute the assets having regard only to the claims of which he then has notice.

Dated 25 June 1992

ARMSTRONG COLLINS AND DELACY, 2 Jennings Street, Kyneton, solicitors for the said trustee 18884

Creditors, next of kin and others having claims in respect of the estate of Christina Anne Marshall late of Lilydale-Monbulk Road, Lilydale in the State of Victoria and formerly of McKillop Road, Mount Evelyn in the State of Victoria, widow, deceased who died on 7 September 1991 are required to send particulars of claims to the executors James Watt Marshall of 5 York Road, Mount Evelyn in the said State and John Harold Marshall of 60 The Esplanade, Elliott Heads in the State of Queensland care of the undermentioned solicitors before the expiration of two calendar months after the date of publication of this notice after which date the said executors will distribute the assets held having regard only to the claims of which they have notice.

EALES & MACKENZIE, solicitors for 114-116 Main Street, Lilydale 18845

NORMAN HENRY RIELLY, late of 15 Quentin Street, Forest Hill in the State of Victoria, retired, deceased

Creditors, next of kin and others having claims in respect of the estate of the deceased (who died on 19 April 1992) are required by the executrix Judith Anne Rielly of 3 Charon Court, Frankston, swimming instructress, to send particulars to her, care of the undersigned, on or before 15 September 1992 after which date she will distribute the assets having regard only to the claims of which she then has notice.

BAYLOR & CO., solicitors, 1 Walkers Road, Nunawading 18843

CLILFFORD BURVILL, formerly of Sunny Creek Road, Trafalgar, but late of Fairview Homes for the Aged, Warragul, retired, deceased

Creditors, next of kin and others having claims in respect to the estate of the deceased who died on 23 February 1992 are required by the trustee Neil Burvill to send particulars of their claims to him care of the undersigned solicitors by 30 August 1992 after which date the trustee may convey or distribute the assets having regard only to the claims of which he then has notice.

GRAY, FRIEND & LONG, solicitors, Warragul 18844

Creditors, next of kin and others having claims in respect of the estate of Florence May Hoysted, late of "Avonlea Grange", Patty Street, Mentone, Victoria, widow, deceased (who died on 18 March 1992) are required by the executrix Patricia Frances Reeves to send particulars to her care of the undersigned solicitors by a date not later than two months from the date of publication hereof after which date she will distribute the assets having regard only to the claims of which notice has been received.

LYTTLETONS, solicitors, 51 Marcus Road, Dingley 18912

ROBERT WILLIAM LEWIS, late of 50 George Street, Ballarat, carpenter, deceased who died on 8 February 1992

Creditors, next of kin and all persons having claims against the estate of the deceased, are required to send particulars to Elizabeth Ann Lewis of 30 Gent Street, Ballarat, State registered nurse, and Peter Timothy Heinz of 6 Dawson Street North, Ballarat, solicitor the

executors on or before 4 September 1992, after which date they will distribute the assets having regard only to the claims of which they shall then have notice.

HEINZ & PARTNERS, solicitors, 6 Dawson Street North, Ballarat 18917

Creditors, next of kin and others having claims in respect of the estate of Cecil Hastings Brown late of 59 Campbell Street, Port Fairy, retired labourer, deceased, who died on 20 April 1992, are requested to send particulars of their claims to the executrix, Gladys Watson of 2 Moore Street, Ashwood, married woman, care of Conlan & Leishman Pty., solicitors, 38 Bank Street, Port Fairy by 8 September 1992, after which date she will distribute the assets having regard only to the claims of which she then has notice.

CONLAN & LEISHMAN PTY., solicitors, 38 Bank Street, Port Fairy 18918

Creditors, next of kin and others having claims in respect of the estate of Gladys Ella Stephens, late of Apartment 108, Cumberland View Retirement Village, Wheelers Hill, widow, deceased, who died on 27 April 1992, are required by Rona Margaret Miller fo 8 Sinclair Street, Drouin and Edna Lynette Kincaid of 84 Church Street, Drouin, to send particulars of their claims to them by 4 September 1992, after which date they will convey or distribute the assets having regard only to the claims of which they then have notice.

M. DAVINE & CO., solicitors, 5 Smith Street, Warragul 18908

Creditors, next of kin and others having claims in respect of the estate of Elsa Myra Helene Reed, late of 1 Cambridge Street, Lang Lang in the State of Victoria, home duties, deceased, who died on 6 April 1992, are required by the executor of her will John Roy Marshall of Glengyle Warrandyte Road, Kangaroo Ground in the said State, to send particulars to him care of the undermentioned solicitors by 3 September 1992 after which date the executor may convey or distribute the assets having regard only to the claims of which he then has notice.

Dated 26 June 1992

ANDERSON RICE, solicitors, of Level 10, 555 Lonsdale Street, Melbourne 18911

1694 G 25 1 July 1992

Creditors, next of kin and others having claims against the estate of Allan Simpson late of 2 Valley View Road, Glen Iris, Victoria, auctioneer, deceased, who died on 9 May 1991 are requested to send particulars of their claims to Darrell John Simpson of 27 Dorrington Avenue, Glen Iris, Victoria, Ethel Denise Hose of 25 Fairfield Avenue, Camberwell, Victoria and Richard Allan Simpson of 27 Dorrington Avenue, Glen Iris, Victoria, the executors appointed by the will care of the belowmentioned solicitors by 1 September 1992, after which date they will distribute the assets having regard only to the claims at which date they then have notice.

PURVES CLARKE RICHARDS, solicitors,  
of 121 William Street, Melbourne 18933

CLAUDE VINCENT VAUGHAN, late of 14 Walbundry Avenue, North Balwyn, civil engineer, deceased

Creditors, next of kin and others having claims in respect of the estate of the deceased who died on 10 February 1992, are required by Trust Company of Australia Ltd. of 151 Rathdowne Street, Carlton and Geoffrey Norman Vaughan of 31 Yarrbat Avenue, Balwyn to send particulars of their claims to the company and the said Geoffrey Norman Vaughan, by 31 August 1992, after which date they will convey or distribute the assets, having regard only to the claims of which the company and the said Geoffrey Norman Vaughan then have notice.

NEVETT FORD, solicitors, 525 Collins Street, Melbourne 18894

The County Court of the State of Victoria  
SALE BY THE SHERIFF

On 6 August 1992 at 2.30 p.m. at the Sheriff's Office, 8-20 King Street, Oakleigh (unless process be stayed or satisfied).

Firstly—all the estate and interest (if any) of Geoffrey John Ogge of St. Kilda Motor Inn, 195A Canterbury Road, St. Kilda as registered proprietor of an estate in fee simple in the land described on Certificate of Title Volume 5037 Folio 378 upon which is erected a building known as 6 Nott Street, East Malvern.

Registered Mortgage No. R085975J affects the said estate and interest.

Secondly—(unless process be stayed or satisfied) all the estate and interest (if any) of

Victoria Government Gazette

Geoffrey John Ogge of St. Kilda Motor Inn, 195A Canterbury Road, St. Kilda as registered proprietor of an estate in fee simple in the land described on Certificate of Title Volume 8968 Folio 050 upon which is erected a Strata Title Apartment known as Unit 2, 57 Spencer Street, St. Kilda and Volume 8968 Folio 070 upon which is situated an accessory unit known as Unit 2, 57 Spencer Street, St. Kilda.

Terms—Cash only

18936 E. SMIRL  
Sheriff's Officer

The Supreme Court of the State of Victoria  
SALE BY THE SHERIFF

On 6 August 1992 at 2.30 p.m. at the Sheriff's Office, 8-20 King Street, Oakleigh (unless process be stayed or satisfied).

All the estate and interest (if any) of Glenn Kralik of Unit 2, 51 Southern Road, Heidelberg Heights as shown on Certificate of Title as Glenn Christopher Kralik as joint proprietor with Ariane Marie Delessert of an estate in fee simple in the land described on Certificate of Title Volume 9871 Folio 571 upon while is erected a residential unit known as Unit 2, 51 Southern Road, Heidelberg Heights.

Registered Mortgage Nos. P210461R and P437103Y affects the said estate and interest.

Terms—Cash only

18937 E. SMIRL  
Sheriff's Officer

The County Court of the State of Victoria  
SALE BY THE SHERIFF

On 6 August 1992 at 2.30 p.m. at the Sheriff's Office, 150 Welsford Street, Shepparton (unless process be stayed or satisfied).

All the estate and interest (if any) of W. Kettels of 3 Marie Street, Nagambie shown on Certificate of Title as William August Leslie Kettels tenant in common in equal shares with Emily Augusta Kettels of an estate in fee simple in the land described on Certificate of Title Volume 6349 Folio 767 upon which is erected a dwelling known as 3 Marie Street, Nagambie.

Registered Caveat Nos. J27315, J27316 affects the said estate and interest.

Terms—Cash only

18938 E. SMIRL  
Sheriff's Officer

*Victoria Government Gazette*

G 25 1 July 1992 1695

The Supreme Court of the State of Victoria  
SALE BY THE SHERIFF

On 30 July 1992 at 2.30 p.m. at the Sheriff's Office, 8-20 King Street, Oakleigh (unless process be stayed or satisfied).

All the estate and interest (if any) of Ruth Lee of 47 High Central Road, Macleay Island as shown on Certificate of Title as Ruth May Tak Lee registered proprietor of an estate in fee simple in the land described on Certificate of Title Volume 9534 Folio 945 upon which is a residential dwelling known as 36 Lookover Road, Donvale.

Registered Mortgage Nos. R279899G, R600199W and covenant contained in transfer L484289K affects the said estate and interest.

Terms—Cash only

E. SMIRL  
Sheriff's Officer

NC

**NOTICE OF MAKING OF STATUTORY  
RULES WHICH ARE NOT YET  
AVAILABLE**

Notice is given of the making of the following  
Statutory Rules:

	<i>Estate Agents Act 1980</i>		<i>Residential Tenancies Act 1980</i>
115/1992	Estate Agents and Sub-Agents (Prescribed Courses of Instruction and Examinations) Rules 1992	125/1992	Residential Tenancies Regulations 1992
	<i>State Electricity Commission Act 1958</i>		<i>Small Claims Tribunals Act 1973</i>
116/1992	State Electricity Commission (Registration of Electrical Contractors) Regulations 1992	126/1992	Small Claims Tribunals Regulations 1992
	<i>Police Regulation Act 1958</i>		<i>Environment Protection Act 1970 (No. 8056)</i>
118/1992	Police Regulations 1992	127/1992	Environment Protection (Vehicle Emissions) Regulations 1992
	<i>Gas and Fuel Corporation Act 1958</i>		<i>Registration of Births Deaths and Marriages Act 1959</i>
119/1992	Gas and Fuel Corporation (Gas Installation) Regulations 1992	128/1992	Births Deaths and Marriages (Prescribed Fees) Regulations 1992
	<i>Petroleum Act 1958</i>		<i>Estate Agents Act 1980</i>
120/1992	Petroleum Regulations 1992	129/1992	Estate Agents (Licensing, General, Accounts and Audit) Regulations 1992
	<i>Marketing of Primary Products Act 1958</i>		<i>Guardianship and Administration Board Act 1986</i>
121/1992	Tobacco Leaf Marketing (Producers) Regulations 1992	130/1992	Guardianship and Administration Board (Fees) Regulations 1992
	<i>Survey Co-ordination Act 1958</i>		<i>Crown Proceedings Act 1958</i>
122/1992	Survey Co-ordination (Surveys) Regulations 1992	131/1992	Crown Proceedings Regulations 1992
	<i>Audit Act 1958</i>		<i>Business Franchise Tobacco Act 1974</i>
123/1992	Treasury Regulations 1992	132/1992	Business Franchise (Tobacco and Petroleum Products) Regulations 1992
	<i>Discharged Servicemen's Preference Act 1943</i>		<i>Tattersall Consultations Act 1958</i>
124/1992	Discharged Servicemen's Preference Regulations 1992	133/1992	Tattersall Consultations Regulations 1992
			<i>Estate Agents Act 1980</i>
		134/1992	Estate Agents (Professional Conduct) Rules 1992



*Melbourne and  
Metropolitan Board of  
Works Act 1958*

135/1992 MMBW (Section 239G  
Statement Fee)  
Regulations 1992

*Melbourne and  
Metropolitan Board of  
Works Act 1958*

136/1992 By-law No. 301: Fees for  
Restriction or  
Withdrawal and  
Restoration of Water  
Supply

*Melbourne and  
Metropolitan Board of  
Works Act 1958*

137/1992 By-law No. 303:  
Melbourne and  
Metropolitan Board of  
Works Employees  
Superannuation Fund  
(Amendment)  
Regulations

*Melbourne and  
Metropolitan Board of  
Works Act 1958*

138/1992 MMBW (Rate Certificate  
Fee) Regulations 1992

**NOTICE OF MAKING AND AVAILABILITY  
OF STATUTORY RULES**

In pursuance of the provisions of the  
*Subordinate Legislation Act 1962* and the  
Regulations made thereunder notice is given of the  
making and availability of the following Statutory  
Rules:

Note: The date specified after each Statutory  
Rule is the date it was first obtainable from—  
The Law Printer  
28 Queensbridge Street, South Melbourne, 3205  
Tel: 242 4600

*Supreme Court Act  
1986*

*Corporations  
(Victoria) Act 1990*

98/1992 Supreme Court  
(Corporations) Rules  
1992

26 June 1992 Code D

*Supreme Court Act  
1986*

101/1992 Supreme Court (Chapter II  
Amendment No. 8)  
Rules 1992

26 June 1992 Code A

*Dairy Industry Act  
1984*

102/1992 Dairy Industry  
(Amendment)  
Regulations 1992

26 June 1992 Code A

*Dairy Industry Act  
1984*

103/1992 Dairy Industry (Quality  
Assurance)  
(Amendment)  
Regulations 1992

26 June 1992 Code A

*Health Act 1958*

104/1992 Health (Radiation Safety)  
(Amendment)  
Regulations 1992

26 June 1992 Code A

*The Constitution Act  
Amendment Act 1958*

109/1992 Victorian Parliamentary  
Elections Regulations  
1992

1 July 1992 Code C

1698 G 25 1 July 1992

Victoria Government Gazette

*Alcoholics and Drug-  
dependent Persons Act  
1968*

110/1992 Alcoholics and Drug-  
dependent Persons  
Regulations 1992

29 June 1992 Code A

*Parliamentary  
Salaries and  
Superannuation Act  
1968*

111/1992 Parliamentary Allowances  
(Amendment)  
Regulations 1992

26 June 1992 Code A

*Transport Accident Act  
1986*

113/1992 Transport Accident  
(Charges)  
(Amendment)  
Regulations 1992

26 June 1992 Code A

*Marine Act 1988*

114/1992 Marine (Fees)  
(Amendment)  
Regulations 1992

1 July 1992 Code A

*Water Act 1989*

117/1992 Water (Annual Reporting)  
(Amendment)  
Regulations 1992

30 June 1992 Code A

The retail prices and price codes below will apply from 1 October 1991 to the following products: Acts (New, Reissue and Reprint), Statutory Rules (New, Reissue and Reprint), Parliamentary Papers, Bills and Reports, Special and Periodical Gazettes, and Industrial Awards.

<i>Price Code</i>	<i>No. of Pages (Including cover and blank pages)</i>	<i>Price</i>
A	1-16	\$2.60
B	17-32	\$3.90
C	33-48	\$5.25
D	49-96	\$7.85
E	97-144	\$10.50
F	145-192	\$12.60
G	193-240	\$14.50
H	241-288	\$15.25
I	289-352	\$16.80
J	353-416	\$20.00
K	417-480	\$23.00
L	481-544	\$26.25

A set retail price per issue will apply from 1 October 1991 to:

Government Gazette (General) \$1.60 per issue  
Hansard (Weekly) \$2.60 per issue



.

.

.

.



.

1700 G 25 1 July 1992

*Victoria Government Gazette*



2

3

4

5





---

1702 G 25 1 July 1992

*Victoria Government Gazette*





**CONTENTS**

	Page
Acts of Parliament	1626
Appointments	1659
Contracts Accepted—Amendments	1650
Estates of Deceased Persons	1641
Government Notices	1630
Melbourne Water	1633
Notice of Making of Statutory Rules	1696
Orders in Council—	
Acts—Local Government; Drainage Areas; Country Fire Authority; Public Service; Metropolitan Fire Brigades; Government Employee Housing Authority; Firearms; Crown Land (Reserves); Land; Trustee; Hospitals and Charities; Mineral Resources Development; Lotteries, Gaming and Betting; Racing	1660
Police Sales	1655
Private Advertisements	1672
Proclamations	1626

A Victorian Government Publication

Published by

THE LAW PRINTER

a business unit of

Printing and Publishing Services Victoria (PPSV)

Melbourne Victoria Australia

© State of Victoria 1992

This publication is copyright. No parts may be reproduced  
by any process except in accordance with the provisions  
of the Copyright Act.

Address all inquiries to the Government Printer  
for the State of Victoria

PO Box 292 South Melbourne 3205 Victoria Australia

ISSN 0819—5471

L. V. North, Government Printer Melbourne

**Mail and Bulk Order Sales**

The Law Printer

PO Box 292 South Melbourne 3205

28 Queensbridge Street, South Melbourne

Telephone inquiries (03) 242 4600

Fax (03) 242 4699

**Counter Sales**

Information Victoria Bookshop

318 Lt. Bourke Street Melbourne 3000

Telephone inquiries (03) 651 4100

**Recommended Retail Price \$1.60**