



Victoria Government Gazette

No. G10 Thursday 11 March 1993
By Authority L. V. North, Government Printer Melbourne

GENERAL

Gazette Services

The *Victoria Government Gazette* (VGG) is published by THE LAW PRINTER (PPSV) for the State of Victoria and is produced in three editions.

VGG General is published each Thursday and provides information regarding Acts of Parliament and their effective date of operation; Government notices; requests for tenders; as well as contracts and contracts accepted. Private notices are also published.

VGG Special is published any day when required for urgent or special Government notices. VGG special is made available automatically to subscribers of VGG General.

VGG Periodical is published on Monday when required and includes specialised information eg. Medical, Dental, Pharmacist's Registers, etc.

Government Advertising

Publishing Details

The following Guidelines should be forwarded to ensure publication of Government material in the *Victoria Government Gazette*.

- Duplicate copies should be submitted for use by the Gazette Officer.
- Material submitted to the Executive Council for gazettal will normally be published in the following week's issue.
- Where urgent gazettal is required, contact:
Gerd Gaspar
Gazette Officer
Department of the Premier and Cabinet
Ground Floor 1 Treasury Place
Melbourne 3000
Telephone inquiries (03) 651 5153
Fax No. (03) 651 5014
- Government advertising other than material for the consideration of the Executive Council should be forwarded to the Gazette Office no later than 9.30 a.m. on Tuesday.
- Lengthy or complicated notices should be forwarded several days before publication.
- Proofs will be supplied only when requested or at the direction of the Gazette Officer.
- No additions or amendments to material for publication will be accepted by telephone.

Advertising Rates and Payment General Gazette

Single column x cm/part cm \$2.65
Double column x cm/part cm \$5.30
Full page \$111.00

Periodical Gazette

Full page \$115.50

Special Gazette

Full page \$233.00.

Local Government and Private Advertisements

Publishing Details: Send copy to:

VGG Coordinator
Gazette Advertising
THE LAW PRINTER
28 Queensbridge Street, South Melbourne
(PO Box 292 South Melbourne 3205)
DX19, Melbourne
Telephone inquiries (03) 2424632
Fax No. (03) 2424630

Advertising Rates and Payment General Gazette

Local Government

Single column x cm/part cm \$4.10
Double column x cm/part cm \$8.20
Full page \$171.50

Note: Local Governments do not have to pre-pay.

Private Advertisements

Payment must be received in advance with advertisement details.

30 cents per word—Full page \$180.00

An additional \$3.20 must be included in prepayment if a copy of the gazette is required. Cheques should be made payable to The Law Printer.

These rates apply to advertisements printed on or after 1 January 1993.

Periodical Gazette

Full page \$180.00

Special Gazette

Full page \$360.00

Advertisers should note:

- Signatures (in particular) and proper names must also be in block letters.
- All material should be double spaced.
- Advertisements can be faxed, and a cover sheet should be used, marked to the attention of the Gazette Coordinator. (Private advertisers note: provided credit card details are supplied for payment.)
- Documents not clearly prepared and in the exact format for gazettal will be returned to the sender unpublished.
- Late copy received at THE LAW PRINTER after 11.00 a.m. Monday will be placed in the following issue of VGG, irrespective of any date/s mentioned in the copy (unless otherwise advised).

Copy Deadline

11.00 a.m. Monday

Subscriptions

VGG is available by three subscription services:

General and Special—\$165.00 each year
General, Special and Periodical—\$220.00 each year
Periodical—\$110.00 each year

Subscriptions are payable in advance and accepted for a period of one year. All subscriptions are on a firm basis and refunds for cancellations will not be given.

All payments should be made payable to THE LAW PRINTER.
Subscription inquiries (03) 2424600
Fax (03) 2424699

**PRIVATE
ADVERTISEMENTS**

Planning and Environment Act 1987
BROADMEADOWS PLANNING SCHEME
Notice of Amendment to a Planning Scheme
Amendment L42

The City of Broadmeadows has prepared amendment L42 to the Broadmeadows Planning Scheme.

The amendment affects a site comprising 3 lots. The site is described as Lots 3-5, being No. 227-237 Mickleham Road, Tullamarine. The site is situated on the south west corner of Western Avenue and extends approximately 117m south along Mickleham Road.

The site was recently sold by the Commonwealth Government and is now in private ownership. The amendment proposes to change the Planning Scheme by rezoning the lots from a Commonwealth Government Reservation to a Reserved General Industrial Zone.

The amendment can be inspected at City of Broadmeadows, Municipal Offices, Pascoe Vale Road, Broadmeadows; Department of Planning and Development, 477 Collins Street, Melbourne.

Submissions about the amendment must be sent to City Planner, City of Broadmeadows, Municipal Offices, Pascoe Vale Road, Broadmeadows, 3047 by 8 April 1993.
Dated 8 March 1993

21803 JOHN KARAGEORGE
City Planner

Planning and Environment Act 1987
BRUNSWICK PLANNING SCHEME
Notice of Amendment to a Planning Scheme
Amendment L29

The City of Brunswick has prepared Amendment L29 to the Brunswick Planning Scheme.

The amendment affects land between Clifton Park and properties at 395-423 Albert Street.

The amendment proposes to change the zoning of the land from Proposed Public Open Space to Light Industrial.

The amendment can be inspected at City of Brunswick, 242 Sydney Road, Brunswick; Department of Planning and Development, 477 Collins Street, Melbourne.

Submissions about the amendment must be sent to Manager Urban Planning, City of Brunswick, Locked Bag No. 2, Brunswick 3056, by 15 April 1993.

21816 MARK WALDON
Urban Planner

Planning and Environment Act 1987
BRUNSWICK PLANNING SCHEME
Notice of Amendment to a Planning Scheme
Amendment L30

The City of Brunswick has prepared Amendment L30 to the Brunswick Planning Scheme.

The amendment affects land between Kirkdale Street and the Merri Creek, and extending to both Victoria and Albert Streets.

The amendment proposes to change the zoning of the land from Proposed Public Open Space to Public Open Space.

The amendment can be inspected at City of Brunswick, 242 Sydney Road, Brunswick; Department of Planning and Development, 477 Collins Street, Melbourne.

Submissions about the amendment must be sent to Manager Urban Planning, City of Brunswick, Locked Bag No. 2, Brunswick 3056, by 15 April 1993.

21817 MARK WALDON
Urban Planner

COBURG CITY COUNCIL
Road Discontinuance

Pursuant to section 528 (2) of the *Local Government (Miscellaneous) Act 1958*, the Council of the City of Coburg, at its Ordinary Meeting of Council, held on 2 February 1993, resolved that the road adjacent to No. 24 Harding Street, Coburg, which is shown by hatching on the plan herewith, be discontinued subject to:

- (a) Melbourne Water Corporation and the Mayor, Councillors and Citizens of the Coburg City Council continuing to have and possess the same right, title, power, authority or interest in or in relation to the whole of the land shown by hatching on the said plan as it had or possessed prior to such discontinuance with respect to or in connection with

Victoria Government Gazette

any drains or pipes laid or erected in, on or over such land for the purpose of drainage or sewerage.

- (b) The land in the said road subject to any such right, title, power, authority or interest vesting in the municipality to be retained by it until sold by private treaty.

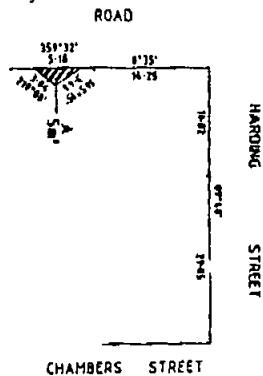

JOSEPH R. DIFFEN
Chief Executive Officer

CITY OF COLAC
Road Discontinuance

Pursuant to section 528 (2) of the *Local Government Act 1958*, the Council of the City of Colac, at its Ordinary Meeting held on 27 January 1993, resolved that the road shown hatched on the plan set out hereunder be discontinued and sold by private treaty.

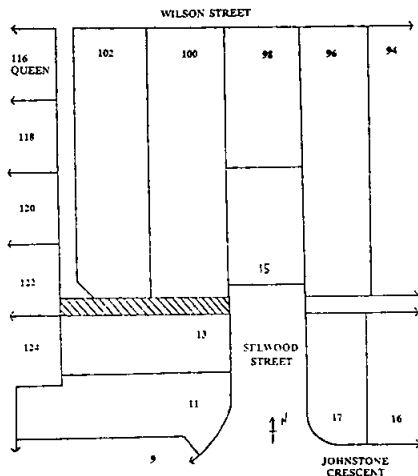

Notwithstanding such discontinuance, the Colac District Water Board shall continue to have and possess the same right, title, power, authority or interest in or relation to the whole of the land as they had or possessed prior to such discontinuance with respect to or in connection with sewerage.

B. R. GREAVES
Town Clerk

21837

CITY OF ESSENDON
Road Discontinuance

Pursuant to section 528 (2) of the *Local Government (Miscellaneous) Act 1958*, the Council of the City of Essendon, at its Ordinary Meeting of Council, held on 22 February 1993, resolved that the road at the rear of No. 1 Geddes Street, bounded by Union Road and Burrows Street, Ascot Vale, which is shown by hatching on the plan herewith, be discontinued subject to:

- (a) Melbourne Water Corporation and the Mayor, Councillors and Citizens of the City of Essendon continuing to have and possess the same right, title, power, authority or interest in or in relation to the whole of the land shown by hatching on the said plan as it had or possessed prior to such discontinuance with respect to or in connection with any drains or pipes laid or erected in, on or over such land for the purpose of drainage or sewerage.
- (b) The land in the said road subject to any such right, title, power, authority or interest vesting in the municipality to be retained by it until sold by private treaty.

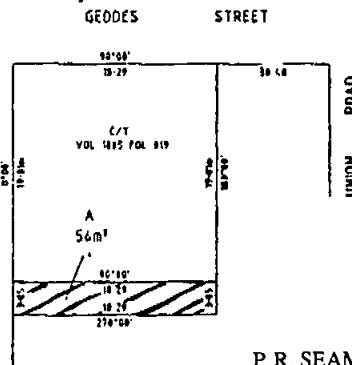

P. R. SEAMER
City Manager

472 G 10 11 March 1993

Planning and Environment Act 1987
FITZROY PLANNING SCHEME
Notice of Amendment
Amendment L23

The City of Fitzroy has prepared an amendment to the Local Section of the Planning Scheme. The amendment is to cover the land formally known as 658-682 Nicholson Street, Fitzroy. The land is situated on the eastern side of Nicholson Street between Scotchmer and Reid Streets.

The amendment proposes to change the zoning from "Light Industrial" to "Residential C", in accordance with a development plan, and to insert a clause into the City of Fitzroy Planning Scheme requiring a Environmental Audit before residential development is commenced.

The amendment may be inspected at Urban Planning Office, City of Fitzroy, Town Hall, 201 Napier Street, Fitzroy; and Department of Planning and Housing, Ground Floor, The Olderfleet Buildings, 477 Collins Street, Melbourne.

Written submissions about this amendment and the accompanying development should be sent to the Strategic Planner, City of Fitzroy, Town Hall, 201 Napier Street, Fitzroy 3065 by 16 April 1993.

L. FRANCESCONI
Chief Executive Officer

21815

CITY OF KEILOR

Notice of Discontinuance and Sale of Portion of Right of Way Between Elizabeth Street and Main Road West, St Albans

Notice is hereby given that the Council of the City of Keilor resolved at its meeting held on 2 March 1993:

"That Council, having formed the opinion that the portion of Right of Way located between Elizabeth Street and Main Road West, St Albans, commencing at Kate Street and extending eastwards for approximately 76.2 metres and being 3.048 metres in width, is no longer required for the purposes for which it was intended, resolved that the Right of Way be discontinued, and that the land be sold by private treaty in accordance with section 528 (2) of the *Local Government (Miscellaneous) Act 1958.*"

Victoria Government Gazette

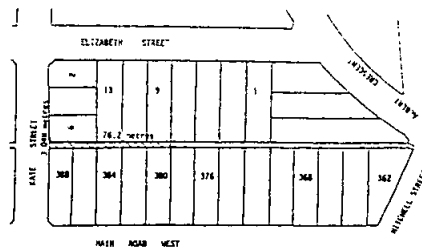

- (a) Statutory Authorities, and the Mayor, Councillors and Citizens of the City of Keilor shall continue to have and possess the same right, title, power, authority or interest in, or in relation to the whole of the land shown on the above plan as it had or possessed prior to such discontinuance in respect to or in connection with any drains or pipes laid or erected in or over such land for the purpose of drainage, sewerage or gas reticulation.
- (b) The land in the said road, subject to any right, title, power, authority or interest, shall vest in the Municipality and be retained by it until sold by Private Treaty.

J. R. CASTLE

21822 Director, Finance and Administration

Planning and Environment Act 1987
KNOX PLANNING SCHEME
Notice of Amendment to a Planning Scheme
Amendment L55

The City of Knox has prepared an amendment which proposes to amend the Local Section of the Knox Planning Scheme, as follows:

Include a special Heritage Buildings and Places Clause (151) with provisions to conserve, enhance and regulate buildings and places of local and historic significance.

The amendment can be inspected at the offices of City of Knox, Civic Centre, 511 Burwood Highway, Knoxfield or Department of Planning and Development, The Olderfleet Buildings, 477 Collins Street, Melbourne, 3000.

Any persons affected by the amendment may make a submission in writing, which must be sent to the City of Knox Civic Centre, 511 Burwood Highway, Knoxfield by 11 April 1993. Dated 4 March 1993

ADRIAN ATKINS
Town Planner

21809

CITY OF NORTHCOTE
Change of Street Name

By resolution of the Council of the City of Northcote, dated 8 February 1993, that section of Clifton Street, Northcote West of Wales Street, Northcote shown as hatched on the accompanying plan has been renamed "Brickworks Lane" to allow for the allocation of street numbers.

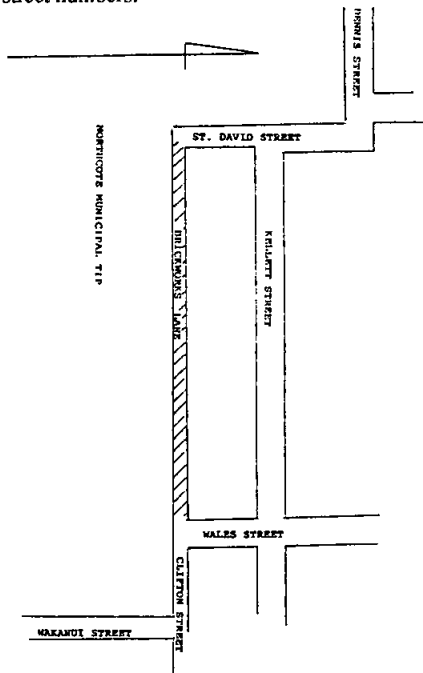

21808

DR DAVID NIVEN
Chief Executive

CITY OF MOE
Draft Local Law No. 6
Liquor in Public Places

The Council has prepared for consideration and comment a Draft Local Law relating to the possession and consumption of alcohol in public places.

Amongst other things, the Draft proposes to require that a Council permit be obtained before any alcohol can be possessed or consumed in a public place.

The Draft is commended for examination and written submissions should be received by me at PO Box 189, Moe 3825 by Friday, 26 March.

Any submissions received will be fully considered by the Council in accordance with the provisions of the *Local Government Act 1989*.

The Draft document is available for inspection at the City Offices Reception area.

J. W. MATHEWS
City Manager/

21838

Chief Executive Officer

Planning and Environment Act 1987
NOTICE OF AMENDMENT TO A
PLANNING SCHEME

The City of Oakleigh has prepared Amendment No. L23 to the Local Section of the Oakleigh Planning Scheme.

The amendment affects all land in the City of Oakleigh.

The amendment proposes to prohibit the future use of land for a Brothel in any zone or reservation within the municipality. The amendment recognises the right of legal brothels currently operating in the municipality to continue to operate notwithstanding the amendment.

A copy of the amendment can be inspected, free of charge, during office hours, at the offices of the City of Oakleigh, Atherton Road, Oakleigh, and the Department of Planning and Development, Ground Floor, 477 Collins Street, Melbourne and Department of Planning and Development, 33-39 High Street, Cranbourne.

Submissions about the amendment must be sent to City of Oakleigh, PO Box 21, Oakleigh, 3166 by 1 April 1993.

Dated 26 February 1993

21802

ADRIAN HALLIDAY
Chief Executive

Planning and Environment Act 1987
BULLA PLANNING SCHEME
Notice of an Amendment to a Planning Scheme
Amendment L73

The Shire of Bulla has prepared Amendment L73 to the Bulla Planning Scheme.

The amendment proposes to change the Planning Scheme by incorporating the policy sections of the recently adopted Shire of Bulla General Plan, Sunbury Strategy, Craigieburn Strategy, Greenvale/Attwood Strategy and Rural Areas Strategy. It is also proposed to include information as to how the Council, as the

474 G 10 11 March 1993

Responsible Authority, will use and review the respective Strategy Plans.

The amendment can be inspected at Shire of Bulla, Municipal Offices at either Macedon Street, Sunbury or Cragieburn Road West, Cragieburn and at the Department of Planning and Development, 477 Collins Street, Melbourne.

Submissions about the amendment must be sent to the Chief Executive Officer, Shire of Bulla, PO Box 42, Sunbury by 3 May 1993.

Dated 9 March 1993

JOHN W. WATSON
Chief Executive Officer

21812

SHIRE OF ELTHAM

Notice of Making of Local Law

Notice is given that at its meeting on 2 March, 1993 Council made the following Local Law:

LOCAL LAW NO. 8—BUILDING CONTROL

The Local Law is made for the purpose of:

1. Providing for the peace, order and good government of the Shire of Eltham;
2. Promoting a physical and social environment free of hazards to health in which the residents of the Municipal District can enjoy a quality of life that meets the general expectations of the community;
3. Preventing and suppressing nuisances which may adversely affect the enjoyment of life within the Municipal District or the health, safety and welfare of persons within the Municipal District;
4. Prohibiting, regulating and controlling activities which may be dangerous or unsafe or detrimental to the quality of life and environment of the Municipal District;
5. Regulating and controlling noise on building sites;
6. Regulating and controlling the siting of buildings; and
7. Repealing Local Law 5 of the Shire of Eltham.

A copy of the Local Law may be inspected at the Shire Offices, 895 Main Road, Eltham during office hours.

R. J. ROSCHOLLER
Chief Executive Officer

21810

Victoria Government Gazette

SHIRE OF HAMPDEN

Notice of Proposed Local Law No. 2

Environment Local Law

The Council of the Shire of Hampden has drafted an Environment Local Law.

This Local Law is made for the purposes of:

- (a) regulating the type of rubbish receptacles to be used and the collection of rubbish; and
- (b) regulating the number of dogs allowed to be kept at an urban property.

Subject to the provisions of this Local Law or without permission from the Council, a person must use a rubbish receptacle which meets the specifications set by the Council and specified materials (eg. trade waste, paint solvents, liquid waste, etc) are prohibited from being placed in rubbish bins. In addition, a landowner or occupier of an urban property shall not keep more than two dogs without the permission of the Council.

A copy of the proposed Local Law can be obtained from the Shire Office in Manifold Street, Camperdown or High Street, Terang.

Any person affected by the proposed Local Law may make a submission relating to the proposed Local Law, in accordance with section 223 of the *Local Government Act* 1989, within fourteen days of the publication of this notice.

Any person requesting to be heard in support of the written submission is entitled to appear before a meeting of the Council (or Committee) either personally or by a person acting on his or her behalf and will be notified of the time and date of the hearing.

STAN DEAN
Municipal Clerk

21818

SHIRE OF HAMPDEN

Streets and Roads Local Law

The Council of the Shire of Hampden has drafted a Streets and Roads Local Law.

This Local Law is made for the purposes of:

- (a) prohibiting street hawkers on streets in the towns;
- (b) prescribing matters to retain visibility for motorists; and
- (c) prescribing fences to retain stock on a property.

Subject to the provisions of this Local Law or without permission from the Council, the following shall apply:

- (i) trees or plants shall not overhang the footpath or roads to obstruct pedestrians or the vision of motorists;
- (ii) boundary fences at an intersection of roads shall not cause an obstruction to pedestrians or motorists;
- (iii) fencing of a property shall be adequate to prevent stock from straying onto the road; and
- (iv) roadside trading will be prohibited without permission from the Council.

A copy of the proposed Local Law can be obtained from the Shire Office in Manifold Street, Camperdown or High Street, Terang.

Any person affected by the proposed Local Law may make a submission relating to the proposed Local Law, in accordance with section 223 of the *Local Government Act 1989*, within fourteen days of the publication of this notice.

Any person requesting to be heard in support of the written submission is entitled to appear before a meeting of the Council (or Committee) either personally or by a person acting on his or her behalf and will be notified of the time and date of the hearing.

21819 STAN DEAN
Municipal Clerk

SHIRE OF HAMPDEN

**Notice of Proposed Local Law No. 4
Building Regulations Siting, Open Living
Space and Exemption for Outbuildings
Local Law**

The Council of the Shire of Hampden has drafted a Building Regulations Siting, Open Living Space and Exemption for Outbuildings Local Law.

This Local Law is made for the purposes of prescribing the minimum requirements for an allotment and the siting of a building, prescribing the minimum open living space for a building or dwelling, and exempting some farmland buildings from the Victoria Building Regulations.

A copy of the proposed Local Law can be obtained from the Shire Office in Manifold Street, Camperdown or High Street, Terang.

Any person affected by the proposed Local Law may make a submission relating to the proposed Local Law, in accordance with section

223 of the *Local Government Act 1989*, within fourteen days of the publication of this notice.

Any person requesting to be heard in support of the written submission is entitled to appear before a meeting of the Council (or Committee) either personally or by a person acting on his or her behalf and will be notified of the time and date of the hearing.

21820 STAN DEAN
Municipal Clerk

SHIRE OF KILMORE

Local Law

Notice is hereby given that the Council of the Shire of Kilmore proposes to make Local Law—Streets and Roads.

Local Law—Streets and Roads

The general purpose of this Local Law is to provide and control the management of traffic, use of roads by persons, vehicles and animals and to regulate the parking of vehicles for the safety and fair use by people in the municipal district.

A copy of the proposed Local Law can be obtained from the Shire Office, Sydney Street, Kilmore.

Persons may make written submissions in respect of this Local Law within fourteen (14) days of the date of this notice. Any submissions will be considered by a Committee of Council in accordance with section 223 of the *Local Government Act 1989*.

Any person lodging a written submission may request to be heard in support of the submission and shall be entitled to appear in person or by a person acting on his or her behalf before a meeting of the Council. Notice of the meeting date and time will be given to all persons lodging submissions.

21835 PETER ANDERSON
Chief Executive Officer

SHIRE OF LEIGH

Local Laws No. 5 & 6

Notice is hereby given that at its meeting of 18 February 1993, Council of the Shire of Leigh made Local Law No 5—Building Regulation, Local Law and Local Law No. 6—Recreation Vehicles, Local Law.

Local Law No. 5—Building Regulations

Purpose of Local Law No. 5 is—

- (a) Exempting class 10 buildings which are constructed on farm land and used

476 G 10 11 March 1993

for farming purposes from all the requirements of the Victoria Building Regulations 1993; and

- (b) To control the location of such exempted Class 10 buildings on farm land so that the safety of persons within the Municipal District is not adversely affected.

Local Law No. 6—Recreation Vehicles

The purpose of Local Law No. 6 is to regulate the use of recreation vehicles on land within the Municipal District.

The Local Law will operate from 4 March 1993. Copies of the Local Law are available for inspection or purchase at the Municipal Offices, Aitchison Street, Rokewood.

GAVIN CATOR
Shire Manager

21804

SHIRE OF MILDURA
Local Law No. 1

Common Seal and Meeting Procedure

Notice is hereby given that at its meeting held on 28 January 1993, the Council of the Shire of Mildura resolved to adopt the amended Local Law No. 1, in accordance with section 119 (3) of the *Local Government Act 1989*.

The amendment is to impose time limits on Councillors Reports during Council Meetings.

A copy of the amended Local Law No. 1, Common Seal and Meeting Procedure is available for inspection during normal office hours at the Shire Offices, Fifteenth Street, Irymple.

Shire Offices, Irymple 3498

DAVID McMILLAN
Shire Secretary

21813

SHIRE OF MILDURA
Local Law No. 1

Common Seal and Meeting Procedure

Notice is hereby given that pursuant to section 119 of the *Local Government Act 1989*, the Shire of Mildura intends to amend Clause 317 of Local Law No. 1.

The amendment removes provisions relating to the introduction of business without notice. A copy of the proposed amendment can be obtained from the Shire Offices, Fifteenth Street, Irymple during normal office hours.

Any person affected by the amendment may make a submission in writing in accordance with section 223 of the *Local Government Act 1989*

Victoria Government Gazette

within fourteen (14) days of the publication of this notice. Persons who wish to appear before the Council in support of their submission, either personally or by representation, must clearly state this in that written submission.

Shire Offices, Irymple 3498

DAVID McMILLAN

Shire Secretary

21814

Planning and Environment Act 1987
SHERBROOKE PLANNING SCHEME
Notice of Amendment
Amendment L71

The Shire of Sherbrooke has prepared Amendment L71 to the Sherbrooke Planning Scheme. The amendment is in two parts.

Part 1

Part 1 of the amendment provides for the renumbering of clauses and schedules in Schedule 14 which have duplicated clause numbers. It also provides for the renumbering of a duplicated clause number in Clause 901—Subdivision Requirements. These changes do not alter the content of any clause or schedule not alter the manner in which they operate in the scheme.

Part 2

This part of the amendment affects land at Lot 43 LP 5726, being No. 18 Edward Street, Upper Ferntree Gully. The amendment proposes to change the Planning Scheme to allow the subject land to be subdivided into two (2) allotments.

The amendment can be inspected free of charge during normal office hours at the Shire of Sherbrooke, Shire Offices, 351 Glenfern Road, Upwey; Upper Yarra Valley and Dandenong, Ranges Authority, Dataplex House, 7-9 John Street, Lilydale and at the Department of Planning and Development, Ground Floor, The Olderfleet Buildings, 477 Collins Street, Melbourne.

Any submissions about the amendment must be made in writing, should state whether the person/s making the submissions wishes to be heard in support of the submission, and must be sent to the Chief Executive Officer, Shire of Sherbrooke, 351 Glenfern Road, Upwey 3158. Submissions must reach the Shire by 14 April 1993.

Dated 10 March 1993

IAN GIBB

21811 Manager—Environmental Planning

Planning and Environment Act 1987

NOTICE OF AMENDMENT TO A PLANNING SCHEME

The Shire of Romsey has prepared Amendment L23 to the Romsey Planning Scheme.

The amendment proposes to change the planning scheme by amending the zoning of the land shown outlined on the plan below from Township Residential B to Highway Business.

The amendment affects land at Part Crown Allotment 32, Section C, Parish of Lancefield. This is situated at the south-east corner of Melbourne-Lancefield Road and Kilmore-Lancefield Road and is commonly known as Macedonia House.

The amendment can be inspected at the office of the Shire of Romsey, Main Street, Romsey and the Department of Planning and Development, 477 Collins Street, Melbourne.

Submissions about the amendment must be sent to the Shire Secretary, Shire of Romsey, Main Street, Romsey by Monday, 12 April 1993.

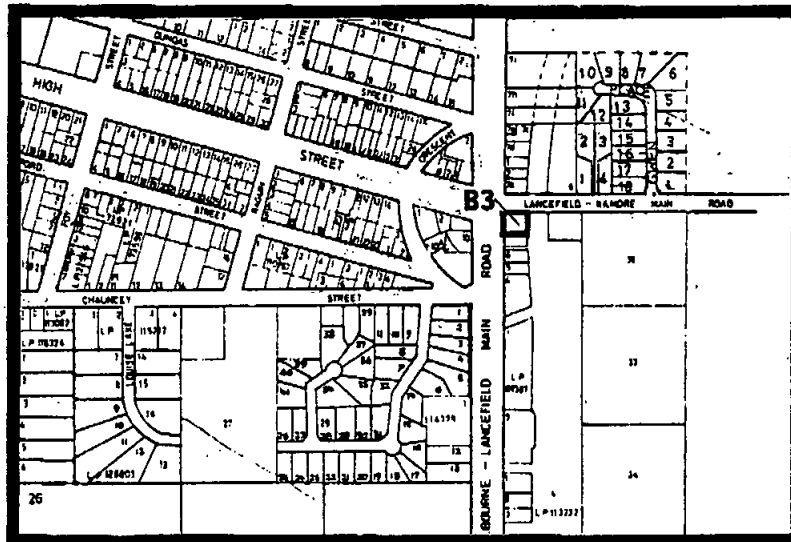

PART OF ROMSEY PLANNING SCHEME MAP No.4

SCALE 1:10,000

LENGTHS ARE IN METRES



LEGEND



HIGHWAY BUSINESS

Planning and Environment Act 1987

SHIRE OF SHEPPARTON

Notice of Amendment to a Planning Scheme

The Shire of Shepparton has prepared Amendment L58 to the Shepparton Shire Planning Scheme, Local Section.

The amendment affects land abutting the Goulburn Valley Highway on the western side of the Highway immediately south of the Broken River, Kialla described as Part Crown Allotment 80, Parish of Kialla.

The amendment proposes to change the Planning Scheme by rezoning some 3 hectares of land from Special Use 3—Caravan Park to Rural C to Highway Commercial—Industrial.

The amendment can be inspected at the offices of the Shire of Shepparton, 21 Nixon Street, Shepparton; Department of Planning and Development, Northeastern Office, State Offices, 1 McKoy Street, West Wodonga; Department of Planning and Development, Olderfleet Buildings, 477 Collins Street, Melbourne.

Submissions about the amendment must be sent to the Shire of Shepparton by 12 April 1993. Dated 23 February 1993

S. P. WINNETT
Manager—Engineering

21836

SHIRE OF ROSEDALE

Land Acquisition and Compensation Act 1986

Notice of Acquisition

Compulsory Acquisition of Interest in Land

The Shire of Rosedale declares that by this notice it acquires the following interest(s) in the land described as—

Lots 2560 and 2561 Caramel Crt, Golden Beach more particularly described in Certificate of Title Volume 8391 Folios 167 and 168 as Lots 2560 and 2561 on Plan of Subdivision No. 56682 Parish of Dungalong.

The interest acquired is the whole of the property.

P. L. TATTERSON
Shire Secretary

21807

UNIVERSITY OF CANBERRA

The Faculty of Education at the University of Canberra will be offering the following courses in Brisbane:

Technical Writing

an intensive 2 day course (13–14 April)

Effective Writing

an intensive 2 day course (15–16 April)

Both are training programs structured in accordance with the provisions of the Commonwealth Training Guarantee Act, 1990.

In-house writing courses also can be designed to suit your specific needs.

The **TECHNICAL WRITING** course is especially suitable for people who have to write procedures or training manuals. It is centred around the essential principles of technical writing, including clear communication, development and testing of the document, final structure and format of the document.

The **EFFECTIVE WRITING** course is centred around a range of topics relevant to effective writing, including a revision of some frequent grammar problems, style, sentence and document construction, letters, briefs, submissions, job applications and reports.

A University certificate is presented to each participant on completion of a course.

Venue: Conference Room
Travel Inn Motel
cnr Gattan & Drummond Sts
Carlton

Times: 9.00am – 4.30pm

Cost: \$400 (includes course handbook, University certificate, morning & afternoon teas)

For further details and registration please contact:

Val Oliver, Faculty of Education
Phone: (06) 201 2470
Fax: (06) 201 5065



U
C

AVON-MACALISTER RIVERS MANAGEMENT BOARD
Extension of Waterway Management District

Notice is hereby given of the Board's proposal to extend its waterway management as shown in the map below—

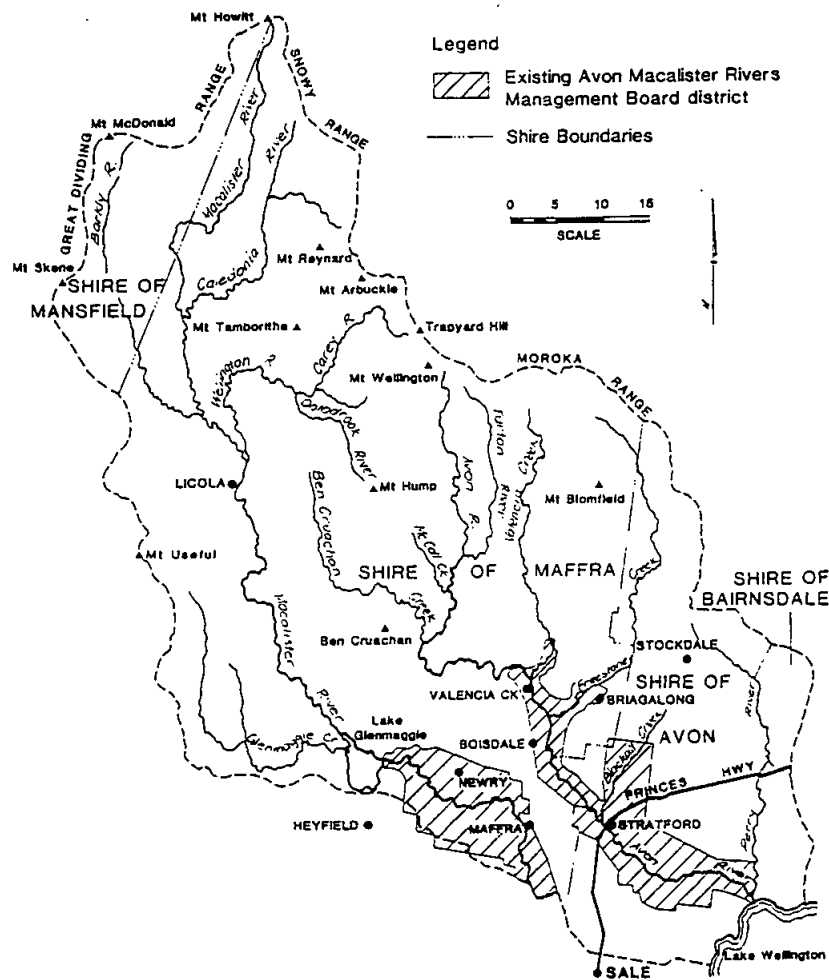

The proposal can be inspected at the Board's Office, Municipal Office, 70 Tyers Street, Stratford, during office hours.

Submissions about the proposal, setting out grounds for any objections raised in it, must be sent to the Secretary, Avon-Macalister Rivers Management Board, PO Box 42, Stratford, Victoria, 3862. The closing date for submissions is Monday, 12 April 1993.

G. W. BRAYSHAW
Secretary

480 G 10 11 March 1993

PORT OF MELBOURNE AUTHORITY

Pursuant to Clause 87 (1) of the *Port of Melbourne Authority Act 1958*, as amended, the Authority has taken immediate remedial action to remove a hull causing an obstruction to the safe and convenient use of the Port of Gippsland Lakes.

The owner of the vessel "Millie" Registered Number RFB 264 is required to take further action to remove the vessel from the Port by taking control of the vessel at the Paynesville Slipyard within thirty (30) days of this notice. Proof of Ownership will be required.

At the expiration of this period the vessel will be offered for sale by tender on an "as is—where is" basis. Pursuant to Clause 87 (4) of the *Port of Melbourne Authority Act 1958* as amended, the Authority will deduct any charges, costs and expenses incurred in and about such removal, sale or disposal and shall pay the surplus (if any) to the owner on demand.

J. S. TURNBULL
Marine Officer, Gippsland

21805

**NOTICE OF RETIREMENT FROM
PARTNERSHIP**

Take notice that Heather Joyce Richardson of 2 Cobble Dick Court, Traralgon 3844, retired from the partnership known as Valley Electronics pursuant to Family Court Orders dated 30 September 1992. Thereafter she will not be responsible for any debts incurred.

Take notice that the partnership between Tony Tripodi Nominees Pty. Ltd. and Bruce David Johnson and Julie Dorothy Johnson which commenced on 6 September 1988, was dissolved on 31 January 1993. Tony Tripodi Nominees Pty. Ltd. will continue operating the business known as "Quo Vadis" at 255-257 Campbell Street, Swan Hill.

Notice is hereby given that with effect from 31 January 1993 Dr Christopher Olszewski has ceased to be a partner in the medical practice known as Sunshine Medical Centre at 104 Monash Street, Sunshine. Dr Shankar Srinivasan and Dr Windsor Choi shall continue in partnership under the above name at the said practice address.

Victoria Government Gazette

Creditors, next of kin or others having claims in respect of the estate of Ruth Louisa Elizabeth Sheppard (also known as Ruth Sheppard), late of 32 Ralston Street, South Yarra, home duties deceased, who died on 28 November 1990, are to send particulars of their claims to the executrix Lila Mary Elizabeth Stickland care of the undermentioned solicitors by 15 May 1993, after which date the executrix will distribute the assets having regard only to the claims of which the executrix then has notice.

OAKLEY THOMPSON & CO., solicitors,
11 High Street, Charlton

Creditors, next of kin or others having claims in respect of the estate of Edward James Gillespie, late of 28 Revell Street, Blairgowrie, deceased, who died on 21 September 1992, are to send particulars of their claims to the executrix care of the undermentioned solicitors by 14 May 1993, after which date the executrix will distribute the assets having regard only to the claims of which she then has notice.

REDMOND & CAMERON, solicitors, 4th
Floor, 472 Bourke Street, Melbourne

Creditors, next of kin or others having claims in respect of the estate of Alma Elizabeth Bonham, late of Curanda Private Nursing Home, 466 Burwood Highway, Wantirna, deceased, who died on 22 November 1992, are to send particulars of their claims to the executrix care of the undermentioned solicitors by 14 May 1993, after which date the executrix will distribute the assets having regard only to the claims of which she then has notice.

REDMOND & CAMERON, solicitors, 4th
Floor, 472 Bourke Street, Melbourne

MARTIN JOHN HIGGINS, late of 83
Highview Crescent, Macleod, Victoria,
retired, deceased

Creditors, next of kin and others having claims in respect of the estate of the deceased, who died on 29 December 1992, are required by the executor Margaret Emma Bettess of care of her below mentioned solicitors to send particulars to her by 4 May 1993, after which date she will convey or distribute the assets having regard only to the claims of which she then has notice.

NICHOLAS O'DONOHUE & CO.,
solicitors, 180 Queen Street, Melbourne

Victoria Government Gazette

Creditors, next of kin and others having claims in respect of the estate of Dorothy Isabel Dudgeon, late of Andrina Nursing Home, 360 New Street, Brighton, spinster, deceased, who died on 23 October 1992, are required by National Mutual Trustees Limited and Harold John Finlayson Dudgeon the executors of the will of the said deceased, to send to them care of the undersigned solicitors particulars thereof by 10 May 1993, after which date they will distribute the assets having regard only to the claims of which they shall then have notice.

GAVAN DUFFY & KING, solicitors, 83 William Street, Melbourne

Creditors, next of kin and others having claims in respect of the estate of Gwenda Ivy O'Bryan, late of 14 Vincent Road, Wangaratta in the State of Victoria, married woman, deceased, who died on 25 July 1992, are required by the executors to send particulars of their claims to the undermentioned solicitors within two months of this notice, after which date the executors will distribute the assets to the persons entitled, having regard only to the claims of which they then have notice.

CAMPAGNA GRAY & MALLINDER, solicitors, 13 Chisholm Street, Wangaratta

Creditors, next of kin and others having claims in respect of the estate of Helen Campbell Levens, late of Lumeah Nursing Home, 78 Bruce Street, West Preston, retired supervisor, deceased, who died on 11 January 1993, are required to send details of their claims to the executrix Heather Mary Crae care of Middletons Moore & Bevins, solicitors, 200 Queen Street, Melbourne by 13 May 1993, after which date the executrix will distribute the estate having regard only to the claims of which she then has notice.

MIDDLETONS MOORE & BEVINS, solicitors, 200 Queen Street, Melbourne

Creditors, next of kin and others having claims in respect of the estate of Harold Leslie Schofield, late of 227 Wood Street, Preston, Victoria, retired, who died on 9 October 1992, are to send particulars of their claims to the executor William Frederick Rendell care of the undermentioned solicitors by 5 May 1993, after which date he will commence to distribute the assets having regard only to the claims of which he then has notice.

RENNICK VERHOEVEN, solicitors, 154 Commercial Road, Morwell

G 10 11 March 1993 481

KEVIN STANISLAUS COGHLAN, late of Bayside Private Hotel, The Esplanade, Elwood, Victoria, gentleman, deceased, intestate

Creditors, next of kin and others having claims in respect of the estate of the deceased, who died on 27 June 1992, are required by Perpetual Trustees Victoria Limited of 50 Queen Street, Melbourne, to send particulars of their claims to the said company by 14 May 1993, after which date it will convey or distribute the assets having regard only to the claims of which the company then has notice.

PETER J. WALSH & JOHN F. CARROLL, solicitors, 83 William Street, Melbourne 21823

KATHLEEN ELEANOR MONIGHETTI, late of Carnsworth Nursing Home, 10 A'Beckett Street, Kew, deceased

Creditors, next of kin and others having claims in respect of the estate of the deceased, who died on 9 October 1992, are required by Perpetual Trustees Victoria Limited of 50 Queen Street, Melbourne, to send particulars of their claims to the said company by 11 May 1993, after which date it will convey or distribute the assets, having regard only to the claims of which the company then has notice. 21824

Creditors, next of kin and others having claims in respect of the estate of Zelvyll Preston Pryce-Jones, late of 10 Wembley Grove, McKinnon, Victoria, retired railway employee, deceased, who died on 15 November 1992, are to send particulars of their claims to the executors care of the undermentioned solicitors by 11 May 1993, after which date the executors will distribute the assets having regard only to the claims of which the executors then has notice.

MADDOCK LONIE & CHISHOLM, solicitors, 440 Collins Street, Melbourne 21825

Creditors, next of kin and others having claims in respect to the estate of Cyril Arthur Agg, late of 71 Bondi Road, Bonbeach, in the State of Victoria, pensioner, deceased who died on 16 December 1992, are required to send particulars of such claims to the executor, National Mutual Trustees Limited of 65 Southbank Boulevard, South Melbourne by 12 May 1993, after which date the executor will distribute the estate having regard only to the claims of which it then has notice. 21828

482 G 10 11 March 1993

ARTHUR ASHWORTH THOMPSON, late of 45 Jardine Street, Corryong in the State of Victoria, pensioner, deceased

Creditors, next of kin and others having claims in respect of the estate of the deceased, who died on 5 September 1992, are required by the executors Audrey Elizabeth Lambert of 45 Jardine Street, Corryong and Maurice Blomley Thompson of 147 Harris Street, Corryong to send particulars to them in care of G. J. Long & Co., solicitors, PO Box 7, Corryong, 3707 by 21 May 1993, after which date the executors may convey or distribute the assets having regard only to the claims of which they then have notice.

Dated 22 February 1993

G. J. LONG & CO., solicitors, PO Box 7, Corryong

Creditors, next of kin and others having claims in respect of the estate of John Richard Peatey, late of 22 Ethel Street, Traralgon, tractor driver, deceased, who died on 5 February 1993, are required by Olive Reynolds of 4/40 Park Lane, Traralgon, home duties and Veronica Joy Battista of 8 Glenview Drive, Traralgon, home duties, executrices of the will of the deceased to send particulars of their claims to them care of the undermentioned solicitors by 31 May 1993, after which date they will convey or distribute the assets having regard only to the claims of which they then have notice.

DAVINE FITZPATRICK & BENNETT, barristers and solicitors, 101 Hotham Street, Traralgon

PETRUCCELLI GIOVANNI, late of 44 Barry Street, West Brunswick, retired, deceased

Creditors, next of kin and others having claims in respect of the estate of the abovenamed deceased who died on 27 December 1991, are to send particulars of their claims to the executrices Maria Donata Rendina and Anastasia Totta, care of the undermentioned solicitors by 7 May 1993, after which date the said executrices will distribute the assets having regard only to the claims of which they then have notice.

O'BRIEN & GALANTE, solicitors, 27 Norwood Crescent, Moonee Ponds

Creditors, next of kin and others having claims against the estate of Joyce Olive Love, late of Unit 71, 59 Gloucester Avenue, Fiddlers Green Village, Berwick, who died on 3 February

Victoria Government Gazette

1993, should send particulars of their claims to the executor Peter Murray Murton at 110 Powlett Street, East Melbourne or to the undersigned no later than 14 May 1993, after which date the assets may be distributed having regard only to claims of which the executor has notice.

G. S. RAY, solicitor, 330 Collins Street, Melbourne

Creditors, next of kin and others having claims in respect of the estate of Karl Fridolf Winter, also known as Charles Winter, late of 1 Park Street, Burnley in the State of Victoria, retired, deceased who died on 21 September 1992 are required by the executors Carl John Winter of 2 Yarilla Road, Sassafra in the said State and Kenneth Charles Winter of 31 Pine Avenue, Camberwell in the said State to send particulars of their claim to them care of the undermentioned solicitors by 8 July 1993, after which date the said executors will distribute the assets of the deceased having regard only to the claims of which they then shall have notice.

JAMES P. DONALD & CO., solicitors, 222 High Street, Kew

Creditors, next of kin and others having claims in respect of the estate of Effie Minnie Checklin, late of 41 Llaneast Street, Melbourne, Victoria, widow, deceased who died on 4 January 1993, are required by the executors of the estate to send particulars of their claims to the executors in the care of the undermentioned solicitors by 6 May 1993, after which date the said executors will distribute the assets having regard only to the claims of which they then have notice.

RIGBY COOKE, solicitors of 242-246 Glenferrie Road, Malvern

Creditors, next of kin or others having claims in respect of the estate of Donald James McCafferty, late of 1 Cole Court, Swan Hill, Victoria, retired viticulturist, deceased who died on 29 October 1992, are required to send particulars of their claims to the executrix, Susan Linda Casey, care of the undermentioned solicitors by 5 May 1993, after which date the executrix will distribute the assets having regard only to the claims of which she then has notice.

GARDEN & GREEN, barristers and solicitors, 4 McCallum Street, Swan Hill

Victoria Government Gazette

LESLIE JOSEPH SHEPPARD, late of 2/9 Head Street, Balwyn

Creditors, next of kin and others having claims in respect of the estate of the deceased who died on 20 December 1992, are required by Paul Francis Sheppard of 14 Ungara Close, North Eltham, the personal representative of the deceased, to send particulars to him by 4 May 1993, after which date he may convey or distribute the assets having regard only to the claims of which he then has notice.

Dated 4 March 1993

COADYS, solicitors, 299 Bridge Road, Richmond, solicitors for the personal representative

Creditors, next of kin and others having claims in respect of the estate of Herbert James Thompson, late of 15 Smythe Street, Benalla in the State of Victoria, retired, deceased, who died on 14 December 1992, are required by the executor, John Staggard of Boals Road, Waaia in the said State to send particulars of their claim to him care of the undermentioned solicitors by 11 May 1993, after which date the said executor will distribute the assets of the deceased having regard only to the claims of which he then shall have notice.

HARRISON DOBSON & COTTRILL, solicitors, 2 Bridge Street, Benalla

Creditors, next of kin and others having claims in respect of the estate of Wilfred Stanley Bullen, late of Flat 10, 19 Murphy Street, Richmond, Victoria, retired, deceased, who died on 21 November 1992, are hereby required to send particulars of their claims to Laurence Frederick L'Estrange, the executor of his estate care of the undermentioned solicitors by 31 May 1993, after which date he will distribute the assets having regard only to the claims of which he then has notice.

L'ESTRANGE & KENNEDY, solicitors, 361 Bridge Road, Richmond

LORNA MARGARET SANDERS, late of Unit 9, 174 Toorak Road, West South Yarra, Victoria, gentlewoman, deceased who died on 2 September 1992

Creditors, next of kin and others having claims in respect of the estate of the deceased, are required by the executrix of her will Patricia Mary Ahern, in the will called Patricia Ahern, of 18A Christowel Street, Camberwell, Victoria,

G 10 11 March 1993 483

home duties, to send particulars thereof to her care of the undermentioned solicitors before 21 May 1993, after which date she may distribute the assets of the deceased having regard only to the claims of which she then has notice.

FREDERICK OWEN & ASSOCIATES PTY. A.C.N. 005 009 601, solicitors of 424 St. Kilda Road, Melbourne 21826

MARY GRAHAM, late of 4 Blair Street, Magazine Hill, Portland, Victoria, spinster, deceased

Creditors, next of kin and others having claims in respect of the estate of the deceased, who died on 4 February 1993, are required by Perpetual Trustees Victoria Limited of 50 Queen Street, Melbourne, Victoria, to send particulars of their claims to the said company by 18 June 1993, after which date it will convey or distribute the assets, having regard only to the claims of which the company then has notice.

DUNHILL MADDEN BUTLER, solicitors, 575 Bourke Street, Melbourne 21827

PAULINE MILLICENT FISHER, late of 21 Ames Avenue, Murrumbena, spinster, deceased

Creditors, next of kin and others having claims in respect of the estate of the deceased, who died on 13 July 1991, are required by the personal representative Graeme Douglas Watson of 5 St. Georges Court, Hoppers Crossing to send particulars to him care of the undermentioned solicitors by 19 May 1993, after which date the personal representative may convey or distribute the assets having regard only to the claims of which he then has notice.

AITKEN WALKER & STRACHAN, solicitors of 114 William Street, Melbourne

BRUCE BUCKLEY, late "Lumeah", Murrabit Road, Culfearn, via Koondrook, Victoria, director of nursing, deceased, intestate, who died on 22 May 1992

Creditors, next of kin and all other persons having claims against the estate of the deceased are required by the Administratrix, Francis Jean Buckley to send particulars to her care of the undersigned on or before 5 May 1993, after which date she will distribute the assets having regard only to the claims of which she then has notice.

GARDEN & GREEN, barristers and solicitors, 4 McCallum Street, Swan Hill

Creditors, next of kin and others having claims against the estate of Iris Kay, late of 26 Bertram Street, Burwood who died on 27 January 1993, should send particulars of their claims to the executors, Peter Murray Murton and Valmai Murton at 110 Powlett Street, East Melbourne or to the undersigned no later than 14 May 1993, after which date the assets may be distributed having regard only to claims of which the executors have notice.

G. S. RAY, solicitor, 330 Collins Street, Melbourne

DAVID LLEWELLYN DICKSON, late of unit one No. 324, Riversdale Road, Hawthorn East, retired, deceased

Creditors, next of kin and others having claims in respect of the estate of the deceased who died on 27 January 1993, are required by the personal representatives, Anna Mary Sturgess of 13 Strawberry Hill, 8 Plunkett Road, The Peak, Hong Kong, Margaret Isla Williams of 26 Spencer Road, Canterbury and Andrew Llewellyn Dickson of 167 Clark Street, Port Melbourne to send particulars to them care of the undermentioned solicitors by 19 May 1993, after which date the personal representatives may convey or distribute the assets having regard only to the claims of which they then have notice.

AITKEN WALKER & STRACHAN, solicitors of 114 William Street, Melbourne

AGNES DORIS McVIE, late of 11 Vauxhall Road, Balwyn, widow, deceased

Creditors, next of kin and others having claims in respect of the estate of the abovenamed deceased are required to send particulars of their claims to the executors, Ian Robin Morrison McVie and Roma Zoe McLean care of the undermentioned solicitor by 31 May 1993, after which date they will convey or distribute the assets having regard only to the claims of which they then have notice.

JAMES HOPPER, solicitor, 409 Whitehorse Road, Balwyn

Creditors, next of kin or others having claims in respect of the estate of Leslie Lamond, late of Unit 2, 5 Parnee Street, Swan Hill, Victoria, widow, deceased who died on 3 November 1992, are required to send particulars of their claims to the executors, Mary Isabel Crossfield and Lesley Alison Lamond, care of the undermentioned solicitors by 5 May 1993, after

which date the executors will distribute the assets having regard only to the claims of which they then have notice.

GARDEN & GREEN, barristers and solicitors, 4 McCallum Street, Swan Hill

Creditors, next of kin and others having claims in respect of the estate of Eva Ruth Eccles, late of "Dalkeith", Marie Street, Traralgon, Victoria, widow, deceased who died on 18 February 1993, are to send particulars of their claims to the executor, David Ian Francis of 35 Ardyne Street, Murrumbena, Victoria, accountant, care of the below mentioned solicitors by 10 May 1993, after which date he will distribute the assets of the deceased having regard only to the claims of which he then has notice.

LITTLETON HACKFORD, solicitors, "Law Chambers", 115-119 Hotham Street, Traralgon

WILFRED TASMAN ROBERTS, formerly of 20 Dunn Street, Warragul but late of 104 Sutton Street, Warragul, Victoria, retired public servant, deceased

Creditors, next of kin and others having claims in respect of the estate of the deceased, who died on 5 March 1992, are required by the trustee Shirley Eileen Heenan to send particulars of their claims to her care of the undersigned solicitors by 15 July 1993, after which date the trustee may convey or distribute the assets having regard only to the claims of which she then has notice.

GRAY, FRIEND & LONG, solicitors, Warragul

Creditors, next of kin and others having claims in respect of the estate of Mabel Jean Dwyer, late of 6 Watson Court, Traralgon, widow, deceased, who died on 18 February 1993, are required by Alan Charles Coxhell of 19 Gillies Crescent, Traralgon, hospital attendant the sole executor of the will of the deceased, to send particulars of their claims to him care of the undermentioned solicitors by 21 May 1993, after which date he will convey or distribute the assets having regard only to the claims of which he then has notice.

DAVINE FITZPATRICK & BENNETT, barristers and solicitors, 101 Hotham Street, Traralgon

ALFRED KAHANOFF, late of 25 Winfield Road, North Balwyn, retired public servant, deceased

Creditors, next of kin and others having claims in respect of the estate of the abovenamed deceased are requested to send particulars of their claims to the executor, Albert Kahanoff, care of the undernoted solicitor by 31 May 1993, after which date he will convey or distribute the assets having regard only to the claims of which he then has notice.

JAMES HOPPER, solicitor, 409 Whitehorse Road, Balwyn

Creditors, next of kin and others having claims in respect of the estate of Bridget Cross (usually known as Bridie Cross) late of Mahogany Lodge, 26 Service Street, Hampton, Victoria, widow, deceased who died on 29 October 1992, are required to send particulars of such claims to the executor, National Mutual Trustees Limited of 65 Southbank Boulevard, South Melbourne, Victoria by 12 May 1992, after which date the executor will distribute the estate having regard only to the claims of which it then has notice.

DARVALL McCUTCHEON, solicitors, 80 Collins Street, Melbourne

Creditors, next of kin and others having claims in respect of the estate of John Patrick Keily, late of 13 Lorne Street, Yarraville in the State of Victoria, pensioner, deceased, who died on 31 March 1992, are requested to send particulars of their claims to the administrator, John Lesley Findlay c/o Wilder Moses Bengasino, solicitors, Suite 8, 233 Cardigan Street, Carlton, in the State of Victoria by 10 May 1993, after which the administrator may administer the estate having regard only to the claims of which it has had notice.

Creditors, next of kin and others having claims in respect of the estate of Joyce Mary Keily, late of 13 Lorne Street, Yarraville in the State of Victoria, home duties, deceased, who died on 2 May 1992, are requested to send particulars of their claims to the substituted executor, John Lesley Findlay care of Wilder

Moses Bengasino, solicitors, Suite 8, 233 Cardigan Street, Carlton, in the State of Victoria by 10 May 1993, after which date the substituted executor will distribute the assets having regard only to the claims of which it then has notice.

Creditors, next of kin or others having claims in respect of the estate of Alvie Lesley Grace, late of "Broughton Hall", 2 Berwick Street, Camberwell, Victoria, widow, deceased who died on 29 May 1992, are required to send particulars of their claims to the executors, Rosemary Beatrice Campbell Kennon and Lesley Jane Campbell Ashton, care of the undermentioned solicitor by 5 May 1993, after which date the executors will distribute the assets having regard only to the claims of which they then have notice.

GARDEN & GREEN, barristers and solicitors, 4 McCallum Street, Swan Hill

Creditors, next of kin or others having claims in respect of the estate of Marjorie Beatrice Thompson, late of Murray Valley Highway, Lake Boga, Victoria, widow, deceased who died on 4 October 1992, are required to send particulars of their claims to the executors, Allan Graham Thompson and Suzanne Margaret Mitchell, care of the undermentioned solicitors by 5 May 1993, after which date the executors will distribute the assets having regard only to the claims of which they then have notice.

GARDEN & GREEN, barristers and solicitors, 4 McCallum Street, Swan Hill

ANNIE ADELAIDE LONG, late of 1/7 Sylvan Grove, Pascoe Vale, widow, deceased

Creditors, next of kin and others having claims in respect of the estate of the abovenamed deceased, who died on 20 December 1992, are to send particulars of their claims to the executrix Patricia Dixon, care of the undermentioned solicitors by 7 May 1993, after which date the said executrix will distribute the assets having regard only to the claims of which she then has notice.

O'BRIEN & GALANTE, solicitors, 27 Norwood Crescent, Moonee Ponds

Unclaimed Moneys Act 1962

Register of Unclaimed Moneys held by the—

Name of Owner on Books and Last Known Address	Total Amount Due to Owner	Description of Unclaimed Money	Date when Amount first became Payable
§			
GENERAL MOTORS ACCEPTANCE CORPORATION AUSTRALIA			
Macdonald, B M and Lawson, W E, RSD 1648 Cramtree Rd, Grove, Tas	10.55	Rebate	16.8.90
Tharp, David, 111 Henderson St, Stawell	39.36	"	13.8.90
Peters, Adrian, 2/22 Clifton St, Richmond	169.36	Overpayment	4.9.90
Brown, Robert T, Carney's Rd, Wonthaggi	52.77	Rebate	5.12.90
Thomas, R K, 6 Caroline St, Thomastown	249.32	"	14.9.90
Tyrell, L and Cole, G, 3/18 Robina St, Frankston	204.99	"	1.10.90
Peters, A, 2/22 Clifton St, Richmond	269.36	Overpayment	5.10.90
Elkins, C A and S, 40 Consord Circuit, St Albans	110.25	Rebate	16.1.91
Perkins, Robert, 3 Lyoia Ave, Campbellfield	261.15	"	31.1.91
Otte, M J, 373A Avoco St, Randwick, NSW	10.00	"	6.2.91
Leong, Wai T and Wong, G, 66 Beverley St, Doncaster East	30.60	"	20.2.91
Blake, J R, 36 Elizabeth St, Coburg	14.55	"	7.3.91
Korp, J W, 10 Bank St, Craigieburn	116.63	"	25.3.91
Arbuckle, C L, 85 Graham St, Albert Park	22.84	"	25.3.91
Fowler, Justin, 357 Centre Rd, Berwick	14.45	"	2.4.91
Pullen, E M, 4/12 Auburn Rd, Hawthorn	238.48	Overpayment	4.4.91
Folino, C and J, 6 Borker Crt, Endeavour Hills	44.20	Rebate	9.4.91
D'Alessandro, T, 690 Waverly Rd, Chadstone	406.79	Overpayment	11.4.91
Williams, P J, 18 Killeen St, Sunshine	34.00	Rebate	3.5.91
Nguyen, Huut, 19 Hilgray St, Coolaroo	474.72	"	14.5.91
Reade, Garry A, 6/26 Merler Rd, Armadale	119.95	Overpayment	20.5.91
Kwan, Kent, 12/157 Power St, Hawthorn	28.04	"	21.5.91
Cully, K C, 10 Wynward Way, Thornlie, WA	55.60	Rebate	24.5.91
Porter, Wayne D, 90 Tyquin St, Laverton	12.00	"	25.6.91
Garraway, Shane, 8 Forrester St, Essendon	13.00	"	12.7.91
Jones, C, 9 Marawarra Dr, Delacombe	21.58	"	19.7.91
Tran, Quang D, 2/7 Bennett St, Richmond	75.55	"	31.7.91
Spittal, H, Flat 4/31 Durrit St, Carlton	243.43	"	12.7.91
Mega, Wally, 34 Merton St, Laverton	328.78	"	16.7.91
Amiri, Mohammed W, c/o I Salehi, 10 Liberator St, Ashburton 1139	169.88	Overpayment	11.7.91

COLES MYER SUPERANNUATION FUND

Hearn, Laurence, 1 Beaconsfield Tce, Riton, Qld 1138	678.50	S'annuation	17.1.92
---	--------	-------------	---------

The Supreme Court of the State of Victoria
SALE BY THE SHERIFF

On 15 April 1993 at 11.00 a.m. at the Sheriff's Office, 107 Baxter Street, Bendigo (unless process be stayed or satisfied).

All the estate and interest (if any) of Leigh Barnett of 12 Dare Street, Bendigo as shown on Certificate of Title as Leigh Douglas Barnett as proprietor as tenant in common to one equal undivided half part or share with Cecil Ernest Charles Barnett and Edith Irene Barnett as joint proprietors as to the other one equal undivided

half part or share of an estate in fee simple in the land described on Certificate of Title Volume 9011 Folio 101 upon which is erected a residential dwelling known as 12 Dare Street, Bendigo.

Registered Mortgage Nos. M293004D, R72173L and Caveat Nos. L768649T, R406722V affect the said estate and interest.

Terms—Cash only

21833

E. SMIRL
Sheriff's Officer

The Supreme Court of the State of Victoria
SALE BY THE SHERIFF

On 15 April 1993 at 2.30 p.m. at the Sheriff's Office, 8-20 King Street, Oakleigh (unless process be stayed or satisfied).

All the estate and interest (if any) of Margaret Weinert of 231 Monbulk Road, Upper Ferntree Gully as shown on Certificate of Title as Margaret Heather Weinert joint proprietor with Graeme James Weinert of an estate in fee simple in the land described on Certificate of Title Volume 9548 Folio 990 upon which is erected a residential property known as 231 Monbulk Road, Upper Ferntree Gully.

Registered Mortgage No. P236506R affects the said estate and interest.

Terms—Cash only

21829

E. SMIRL
Sheriff's Officer

The Supreme Court of the State of Victoria
SALE BY THE SHERIFF

On 15 April 1993 at 2.30 p.m. at the Sheriff's Office, 8-20 King Street, Oakleigh (unless process be stayed or satisfied).

All the estate and interest (if any) of Edward George Artz and Kerrie Georgina Artz of 192 Beach Road, Black Rock as shown on Certificate of Title as Keri Gerogina Artz and Edward Geroge Artz joint proprietors of an estate in fee simple in the land described on Certificate of Title Volume 8683 Folio 155 upon which is erected a dwelling known as 192 Beach Road, Black Rock.

Registered Mortgage No. N328613W affects the said estate and interest.

Terms—Cash only

21830

E. SMIRL
Sheriff's Officer

The County Court of the State of Victoria
SALE BY THE SHERIFF

On 15 April 1993 at 2.30 p.m. at the Sheriff's Office, 8-20 King Street, Oakleigh (unless process be stayed or satisfied).

All the estate and interest (if any) of Chardone Pty. Ltd. of 70 Wells Road, Frankston as registered proprietor of an estate in fee simple in the land described on Certificate of Title Volume 8402 Folio 398 upon which is erected a brick veneer house known as Lot 3 Boundary Road, Narre Warren. The property is on the

northern side of Boundary Road, located 276.3 metres east from Greenwood Road and 810.3 metres west from Berwick Road and has a frontage of 710 metres.

Registered Mortgage Nos. N699857U and P645975G affect the said estate and interest.

Terms—Cash only

21834

E. SMIRL
Sheriff's Officer

The Supreme Court of the State of Victoria
SALE BY THE SHERIFF

On 15 April 1993 at 2.30 p.m. at the Sheriff's Office, 8-20 King Street, Oakleigh (unless process be stayed or satisfied).

All the estate and interest (if any) of Victoria Louise Wilcox of Lot 61 Rochussen Court, Mount Eliza as registered proprietor of an estate in fee simple in the land described on Certificate of Title Volume 9971 Folio 679 upon which is erected a dwelling known as 121 Grant Road, Mount Eliza.

Registered Mortgage No. R618831B, Caveat No. S162079L and the covenant contained in transfer R618830E affect the said estate and interest.

Terms—Cash only

21831

E. SMIRL
Sheriff's Officer

The Supreme Court of the State of Victoria
SALE BY THE SHERIFF

On 15 April 1993 at 11.00 a.m. at the Sheriff's Office, 1 Feeley Lane, Traralgon (unless process be stayed or satisfied).

All the estate and interest (if any) of Alan Norman Gray of 45 Collison Road, Cranbourne as registered proprietor of an estate in fee simple in the land described on Certificate of Title Volume 9493 Folio 880 which is vacant land known as Crown Allotment 5, Section 1, Watts Road, Nyora. The land commences 80.47 metres east of the northeast corner of Patman Drive and Watts Road, Nyora and having a frontage to Watts Road of 20.12 metres and a depth of 70.41 metres. It is located on the northern side of Watts Road.

Registered Mortgage Nos P578617J and P787585W affect the said estate and interest.

Terms—Cash only

21832

E. SMIRL
Sheriff's Officer

PROCLAMATIONS

Land Act 1958
PROCLAMATION OF ROAD

I, Richard E. McGarvie, Governor of Victoria acting with the advice of the Executive Council and under section 25 (3) (c) of the *Land Act 1958* proclaim as road the following land:

MUNICIPAL DISTRICT OF THE CITY OF PORTLAND

PORTLAND—The land in the Township of Portland, Parish of Portland as indicated by hatching on plan hereunder—(P 69(10)) (Rs 3925).

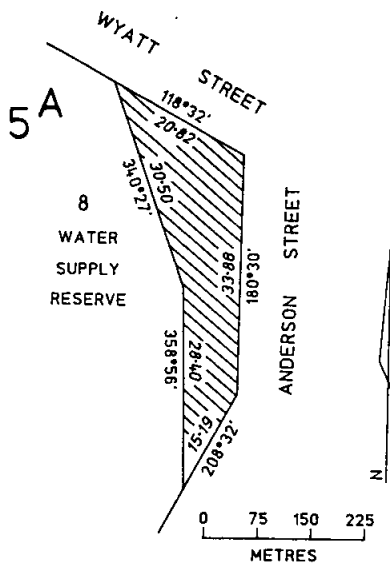

Given under my hand and the seal of Victoria on 5 March 1993

(L.S.) R. E. McGARVIE
By His Excellency's Command
M. A. BIRRELL
Minister for Conservation and Environment

Land Act 1958
PROCLAMATION OF ROADS
I, Richard E. McGarvie, Governor of Victoria, acting with the advice of the Executive Council and under section 25 (3) (c) of the *Land Act 1958* proclaim as roads the following lands:

MUNICIPAL DISTRICT OF THE SHIRE OF CRESWICK

CRESWICK—Crown Allotment D3, Parish of Creswick, as shown on Certified Plan No. 111793 lodged in the Central Plan Office—(Rs 11107).

MUNICIPAL DISTRICT OF THE SHIRE OF STAWELL

MOKEPILLY—The land in the Parish of Mokepilly as indicated by hatching on plan hereunder—(3140) (Rs 35120).

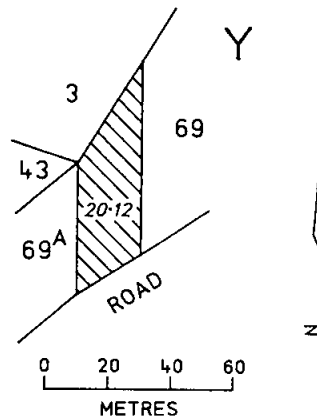

Given under my hand and the seal of Victoria on 5 March 1993

(L.S.) R. E. McGARVIE
By His Excellency's Command
M. A. BIRRELL
Minister for Conservation and Environment

Land Act 1958
PROCLAMATION OF ROADS
I, Richard E. McGarvie, Governor of Victoria acting with the advice of the Executive Council and under section 25 (3) (c) of the *Land Act 1958* proclaim as roads the following lands:
MUNICIPAL DISTRICT OF THE SHIRE OF BET BET
TARNAGULLA—Crown Allotment 143X, Section C, Parish of Tarnagulla as shown on Certified Plan No. 111146 lodged in the Central Plan Office—(P 132836).

Victoria Government Gazette
MUNICIPAL DISTRICT OF THE SHIRE OF
WIMMERA

G 10 11 March 1993 489

WAIL—Crown Allotment 1A, Section B,
Parish of Wail as shown on Certified Plan No.
110307 lodged in the Central Plan Office—(LA-
4774).

Given under my hand and the seal of
Victoria on 10 March 1993

RICHARD E. MCGARVIE
By His Excellency's Command
M. A. BIRRELL
Minister for Conservation and Environment

Agricultural and Veterinary Chemicals
Act 1992

PROCLAMATION OF COMMENCEMENT

I, Richard E. McGarvie, Governor of
Victoria, acting with the advice of the Executive
Council and under section 2 of the *Agricultural*
and Veterinary Chemicals Act 1992, fix 11
March 1993 as the day on which sections 1, 2, 3,
4, 5, 19 (4), 19 (5), 25, 27, 53, 54, 62, 68, 69, 70,
71, 72, 73, 74, 75, 76 and Schedule 1 of the Act
come into operation.

Given under my hand and the seal of
Victoria on 10 March 1993

RICHARD E. MCGARVIE
By His Excellency's Command
BILL McGRATH
Minister for Agriculture

Agricultural and Veterinary Chemicals
Act 1992

PROCLAMATION OF COMMENCEMENT

I, Richard E. McGarvie, Governor of
Victoria, acting with the advice of the Executive
Council and under section 2 of the *Agricultural*
and Veterinary Chemicals Act 1992, fix 11
March 1993 as the day on which sections 65, 66
and 67 of the Act come into operation.

Given under my hand and the seal of
Victoria on 5 March 1993

(L.S.) R. E. MCGARVIE
By His Excellency's Command
BILL McGRATH
Minister for Agriculture

GOVERNMENT NOTICES

TRAVEL AGENTS LICENSING AUTHORITY

The Travel Agents Licensing Authority hereby publishes amendments to the list of licensed travel agents published in the *Victoria Government Gazette* No. G48 dated 9 December 1992 and to subsequent monthly amendments.

Suppliers of travel services should not deal with a person or corporation not included on the list, unless that person or corporation is able to produce a travel agent's licence or can satisfy the supplier that he or she or it is exempt from being required to hold a licence.

In accordance with section 37 (2A) of the *Travel Agents Act* 1986, amendments to this list will be published in the first V.G.G. of each month. A complete list will be published in June 1993.

C. TIKOTIN, Registrar
Travel Agents Licensing Authority

AMENDMENTS TO LIST OF LICENSED TRAVEL AGENTS

Date of preparation: 9 March 1993

1. The following Travel Agents and/or business names are to be ADDED to the list of Licensed Travel Agents:

<i>Name under which business conducted</i>	<i>Licensee</i>	<i>Licence Number</i>
Abelair Travel Centre	Ellis, Pippa Ann	31762
CFT Travel	Tomaino, Carlo Francesco	31758
CFT Travel	Tomaino, Tomasina Lena	31759
Dial Travel Pty Ltd	Dial Travel Pty Ltd	31697
Direct Flights Pty Ltd	Direct Flights Pty Ltd	31760
Emu Enterprises Australia Pty Ltd	Emu Enterprises Australia P/L	31752
Experienced World Travel P/L	Experienced World Travel P/L	31734
Harvey World Travel (Cranbourne)	Replan Pty Ltd	31733
Harvey World Travel (Ivanhoe)	Dateline International Travel Service Pty Ltd	31532
Leisure Holidays	Surfers Paradise Holidays & Accommodation Pty Ltd	30057
Rushdown Travel Pty Ltd	Rushdown Travel Pty Ltd	31665
Southgate Travel Pty Ltd	Southgate Travel Pty Ltd	31751
Suburban Travel Network Pty Ltd	Suburban Travel Network Pty Ltd	31764
The Travel Edge Pty Ltd	The Travel Edge Pty Ltd	31737
Tick-It Travel	Globetrotter Pty Ltd	31768
Trans Turk Travel Services Pty Ltd	Trans Turk Travel Services Pty Ltd	31765
Transit Travel Pty Ltd	Transit Travel Pty Ltd	31625
Travel Horizon Pty Ltd	Travel Horizon Pty Ltd	31753
Tremont Travel Services	Intelvation Pty Ltd	31769
Wandana The Travel Professionals	Wandana Travel (Vic.) Pty Ltd	31730

2. The following Travel Agents and/or business names are to be DELETED from the list of Licensed Travel Agents:

<i>Name under which business conducted</i>	<i>Licensee</i>	<i>Licence Number</i>
Angkor Travel	Angkor Holdings Pty Ltd	31608
Australia Euro Pacific Travel & Tours	Mastroianni Real Estate Pty Ltd	30295
Forward Travel Pty Ltd	Forward Travel Pty Ltd	31378
Intersales Travel & Tours	Tanvale Pty Ltd	30045
Landmark Travel	Ayrwood Nominees Pty Ltd	31401
Mondo Travel Agency	Indus Valley Pty Ltd	31203
Rushdown Travel	Rush, Melissa Anne Mary	31399
Travelguide Enterprises	Novasan Pty Ltd	31459
Travel World Wangaratta	Aprichest Pty Ltd	31312

Forests Act 1958, No. 6254

VARIATION OF PROHIBITED PERIOD

In pursuance of the powers conferred by section 3 sub-section (2) of the *Forests Act 1958*, I, Rod Incoll, delegated officer for Her Majesty's Minister for Conservation and Environment in the State of Victoria, hereby vary the Prohibited Period in respect to the fire protected areas (other than State Forest, National Park and Protected Public Land) within the municipalities nominated in the schedule hereunder:

SCHEDULE 1

The Prohibited Period shall end at 0100 hours on Monday, 15 March 1993 in the following municipalities:

Shire of Beechworth; Shire of Myrtleford; Shire of Yackandandah; Shire of Upper Murray; Shire of Maffra; Shire of Traralgon; Shire of Rosedale; Shire of Bairnsdale; Shire of Mansfield; Shire of Broadford; Shire of Seymour; Shire of Yea; Shire of Chiltern; Rural City of Wodonga; Shire of Tallangatta; Shire of Bright; Shire of Morwell; Shire of Avon; Shire of Whittlesea; Shire of Tambo; Shire of Alexandra; Shire of Kilmore; Shire of Pyalong; Shire of Benalla.

R. A. INCOLL
Chief Fire Officer
Department of Conservation and Natural
Resources Delegated Officer,
pursuant to section 11,
Conservation Forests and Land Act 1987

Education Act 1958

NOTICE OF THE MAKING OF AN ORDER
UNDER SECTIONS 13 (4) AND (5) OF THE
ACT

Under section 13 (4) of the *Education Act 1958*, I hereby give notice that an Order of the Governor in Council was made on 5 March 1993 dissolving the Turana Youth Training Education Centre Council and under sub-section (5) directing the disposal of any assets of the Turana Youth Training Education Centre Council.

DON HAYWARD
Minister for Education

Vocational Education and Training Act 1990

NOTICE OF DETERMINATION OF
APPROVED TRAINING PROGRAMS

In accordance with section 51 of the *Vocational Education and Training Act 1990* the State Training Board has determined that the following training programs are approved training programs for the vocations specified below:

<i>Vocation</i>	<i>Approved Training Program</i>
1. Furnishings Industry	Traineeship
2. Financial Services	Traineeship
3. TCF Carpet Industries	Traineeship

Details of the approved training programs can be obtained from the Executive Director, Vocational Training Bureau, Office of Training and Further Education, Rialto South Tower, 525 Collins Street, Melbourne 3000. Telephone 628 3339. Fax.: 628 3966.

Road Safety Act 1986

ORDER UNDER SECTION 98 ROAD SAFETY ACT 1986
TO CERTAIN LAND UNDER THE CONTROL OF THE SHIRE OF BULLA

I, William Robert Baxter, Minister for Roads and Ports, under section 98 of the *Road Safety Act 1986* by this Order extend the application of—

- (a) sections 59, 64–65, 76–77, 85–90, 99 and 100 of the Act; and
 - (b) the Road Safety (Traffic) Regulations 1988; and
 - (c) parts 7 and 8 and Schedules 5 and 6 of the Road Safety (Procedures) Regulations 1988—
- to land, under the control of the Shire of Bulla, particulars of which are shown on the following plan.

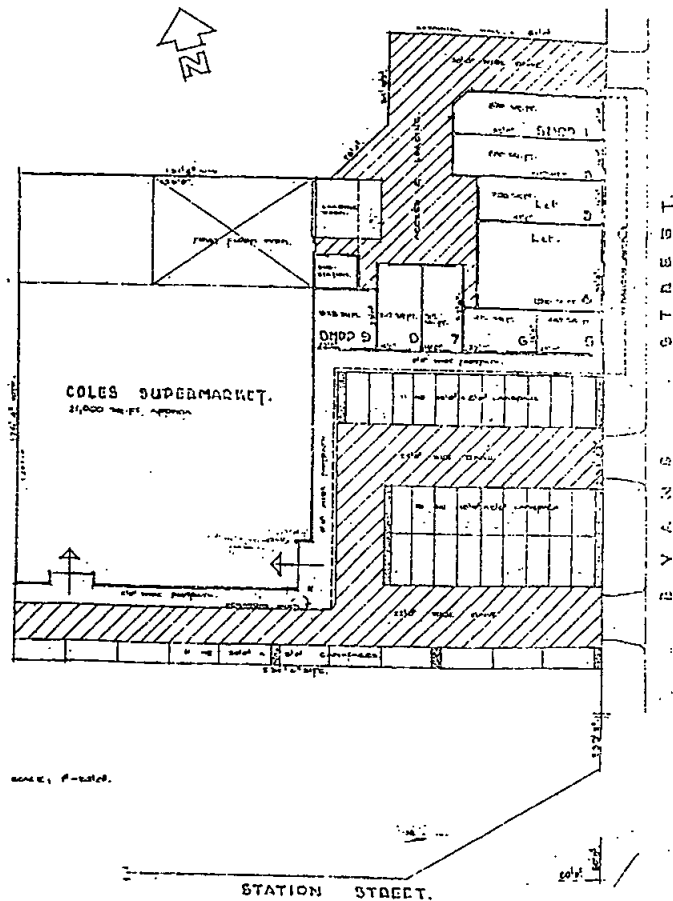

Dated 26 February 1993

W. R. BAXTER
Minister for Roads and Ports

Road Safety Act 1986
ORDER UNDER SECTION 98 ROAD SAFETY ACT 1986
EXTENDING PROVISIONS TO COUNCIL CONTROLLED LAND IN THE
CITY OF SUNSHINE

I, William Robert Baxter, Minister for Roads and Ports, under section 98 of the *Road Safety Act 1986* by this Order extend the application of—

- (a) sections 59, 64–65, 76–77, 85–90, 99 and 100 of the Act; and
 - (b) the Road Safety (Traffic) Regulations 1988; and
 - (c) parts 7 and 8 and Schedules 5 and 6 of the Road Safety (Procedures) Regulations 1988—
- to land, under the control of the City of Sunshine, particulars of which are shown on the following plan.

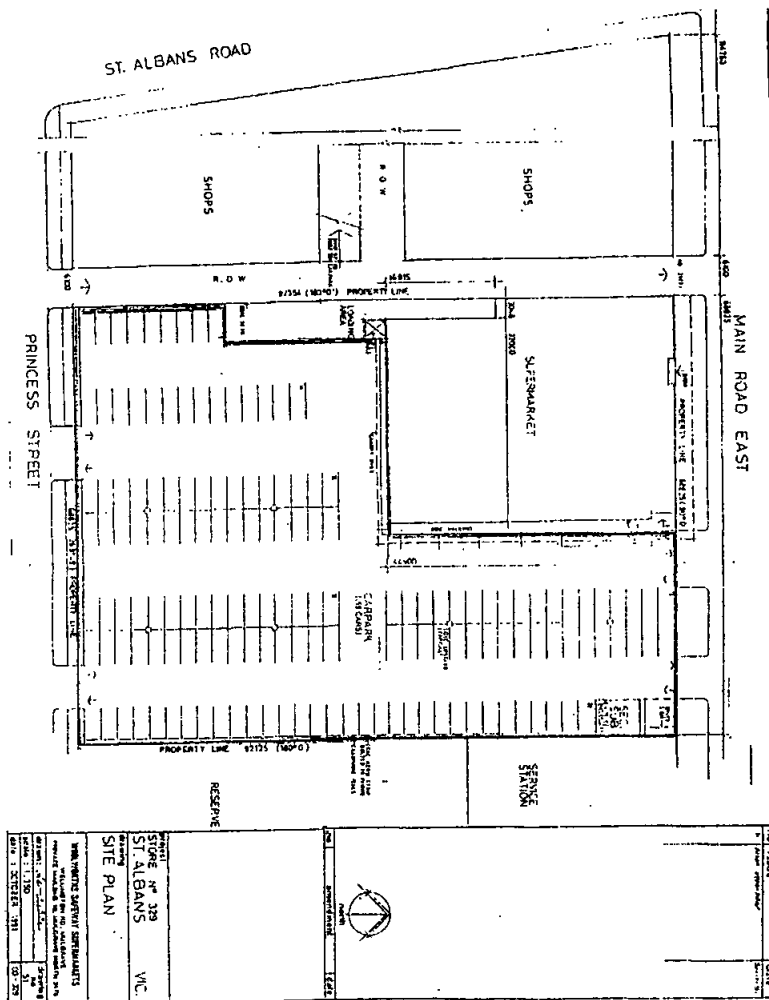

Dated 26 February 1993

W. R. BAXTER
 Minister for Roads and Ports

494 G 10 11 March 1993

Road Safety Act 1986

MOTOR CYCLE RELIABILITY TRIAL

Under section 68 (3) of the *Road Safety Act* 1986, I declare that sub-sections (1) and (2) of section 68 of the Act, the Road Safety (Traffic) Regulations 1988 and Parts 9 and 10 of the Road Safety (Vehicles) Regulations 1988 shall not apply with respect to an event known as the Corner Inlet Motor Cycle Club Reliability Trial to be conducted by the Corner Inlet Motor Cycle Club on sections of road within the Strzelecki State Forest on Sunday, 4 April 1993 between the hours of 8.30 a.m. and 4.00 p.m.

Dated 2 March 1993

N. R. BUTLER
Regional Manager
Vic Roads—Eastern Victoria
Delegate of the Minister for Transport

Victoria Government Gazette
674-680 Glenferrie Road and 2-8 Wakefield Street, Hawthorn, Glenferrie Market.

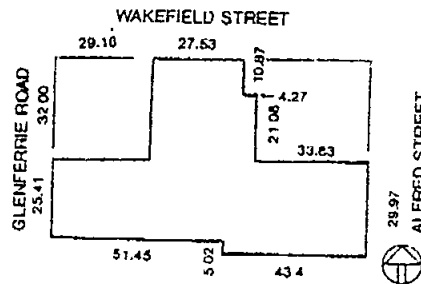

Dated 26 February 1993

W. R. BAXTER
Minister for Roads and Ports

Road Safety Act 1986
**ORDER UNDER SECTION 98
ROAD SAFETY ACT 1986
EXTENDING PROVISIONS TO COUNCIL
CONTROLLED LAND IN THE
CITY OF HAWTHORN**

I, William Robert Baxter, Minister for Roads and Ports, under section 98 of the *Road Safety Act* 1986 by this Order extend the application of—

- (a) sections 59, 64-65, 76-77, 85-90, 99 and 100 of the Act; and
- (b) the Road Safety (Traffic) Regulations 1988; and
- (c) parts 7 and 8 and Schedules 5 and 6 of the Road Safety (Procedures) Regulations 1988—

to land, under the control of the City of Hawthorn, particulars of which are shown on the following plans.

The Tooronga Shopping Centre, corner Tooronga and Toorak Roads.

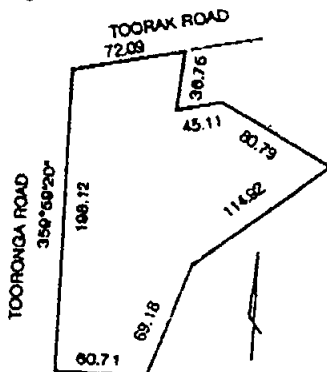

Planning and Environment Act 1987
**MALDON PLANNING SCHEME
Notice of Approval of Amendment
Amendment L5**

The Minister for Planning has approved Amendment L5 to the Maldon Planning Scheme.

The amendment comes into operation on the date this notice is published in the *Government Gazette*.

Amendment L5 deletes the existing Local Section and inserts a new Local Section comprising a detailed ordinance and map sheets.

The new Local Section includes detailed policies, zones and special controls, with provision for historic buildings, sites and areas, and landscape, erosion, fire protection and water course provisions in the rural area. The provisions are similar to those of the existing Planning Scheme and have been revised and rewritten in plain English.

A copy of the amendment can be inspected, free of charge, during office hours, at the offices of the Shire of Maldon, High Street, Maldon; the Loddon-Campaspe Regional Planning Authority, 261 Hargreaves Street, Bendigo and at the Department of Planning and Development, Ground Floor, The Olderfleet Buildings, 477 Collins Street, Melbourne and 426 Hargreaves Street, Bendigo.

GEOFF CODE
Manager
Planning Co-ordination Branch
Department of Planning and Development

Victoria Government Gazette

Planning and Environment Act 1987
TRARALGON (SHIRE) PLANNING
SCHEME

Notice of Approval of Amendment
Amendment L41

The Minister for Planning has approved Amendment L41 to the Traralgon (Shire) Planning Scheme.

The amendment comes into operation on the date this notice is published in the *Government Gazette*.

The amendment rezones 'Rural General Farming' to 'Site Specific' to allow, with Council consent, wedding receptions and party functions at Lot 1, Lodged Plan 99525, part Crown Allotment 9A, Parish of Traralgon, Melrossa Road, Traralgon East.

A copy of the amendment can be inspected, free of charge, during office hours, at the offices of the Shire of Traralgon, corner Breed and Kay Streets, Traralgon and at the Department of Planning and Development, 477 Collins Street, Melbourne.

GEOFF CODE
Manager
Planning Co-ordination Branch
Department of Planning and Development

Planning and Environment Act 1987
NUNAWADING PLANNING SCHEME
Notice of Approval of Amendment
Amendment L55

The Minister for Planning has approved Amendment L55 to the Nunawading Planning Scheme.

The amendment comes into operation on the date this notice appears in the *Government Gazette*.

The amendment corrects an error in the planning scheme by inserting a control for tennis court lighting in the Special Residential Zone No. 5.

A copy of the amendment can be inspected, free of charge, during office hours, at the offices of the City of Nunawading, 379 Whitehorse Road, Nunawading or at the Department of Planning and Development, 477 Collins Street, Melbourne.

GEOFF CODE
Manager
Planning Co-ordination Branch
Department of Planning and Development

G 10 11 March 1993 495

Planning and Environment Act 1987
KOWREE PLANNING SCHEME

Notice of Approval of Amendment
Amendment L3

The Minister for Planning has approved Amendment L3 to the Kowree Planning Scheme.

The amendment comes into operation on the date this notice is published in the *Government Gazette*.

The amendment removes drainage controls and gives the Responsible Authority more discretion to consider permits in the rural zone. The minimum lot size for house is lowered in the rural, rural residential and township zones, subject to the Shire's approval. Provision is made for some land at Lake Toolondo to be zoned rural residential which recognises what exists on the ground.

A copy of the amendment can be inspected, free of charge, during office hours, at the offices of the Shire of Kowree, Municipal Offices, 49 Elizabeth Street, Edenhope, at the Department of Planning and Development, 477 Collins Street, Melbourne and at the Department of Planning and Development, Regional Office, State Government Offices, Ballarat.

GEOFF CODE
Manager
Planning Co-ordination Branch
Department of Planning and Development

Planning and Environment Act 1987
LILLYDALE PLANNING SCHEME
Notice of Lapsing of Amendment
Amendment L102

The Shire of Lillydale has resolved to abandon the above amendment.

The amendment proposed to change the planning scheme by inserting a site specific provision in the planning scheme to enable land at 424-426 Main Street (Lot 10 and Lot 11, LP 1596) Lillydale to be developed as a service station and convenience shop.

The amendment lapsed on 30 October 1992.

GEOFF CODE
Manager
Planning Co-ordination Branch
Department of Planning and Development

496 G 10 11 March 1993

Planning and Environment Act 1987
NUNAWADING PLANNING SCHEME
Notice of Approval of Amendment
Amendment L55

The Minister for Planning and Development has approved Amendment L55 to the Nunawading Planning Scheme.

The amendment comes into operation on the date this notice appears in the *Government Gazette*.

The amendment corrects an error in the planning scheme by inserting a control for tennis court lighting in the Special Residential Zone No. 5.

A copy of the amendment can be inspected, free of charge, during office hours, at the offices of the City of Nunawading, 379 Whitehorse Road, Nunawading or at the Department of Planning and Development, 477 Collins Street, Melbourne.

GEOFF CODE
Manager
Planning Co-ordination Branch
Department of Planning and Development

Planning and Environment Act 1987
LILLYDALE PLANNING SCHEME
Notice of Lapsing of Amendment
Amendment L101

The Shire of Lillydale has resolved to abandon the above amendment.

The amendment proposed to change the planning scheme by rezoning "Nathania Springs" Lot 1, LP 135156, Olinda-Monbulk Road, Monbulk from Restricted Use 6—Restaurant to Restricted Use 5—Major Tourist Development.

The amendment lapsed on 17 February 1993.

GEOFF CODE
Manager
Planning Co-ordination Branch
Department of Planning and Development

Planning and Environment Act 1987
HASTINGS PLANNING SCHEME
Notice of Approval of Amendment
Amendment L36 Part 1

The Minister for Planning has approved Amendment L36 Part 1 to the Hastings Planning Scheme.

The amendment comes into operation on the date this notice is published in the *Government Gazette*.

Victoria Government Gazette

The amendment makes the following changes to the Scheme for the purpose of:

removing over control;
improving consistency and working up-dating provisions
simplifying and improving the effectiveness of the planning scheme making some minor corrections.

For details, refer to the explanatory report contained in the amendment documents.

A copy of the amendment can be inspected, free of charge, during office hours, at the offices of the Shire of Hastings, Marine Parade, Hastings and at the Department of Planning and Development, 477 Collins Street, Melbourne.

GEOFF CODE
Manager
Planning Co-ordination Branch
Department of Planning and Development

Planning and Environment Act 1987
LILLYDALE PLANNING SCHEME
Notice of Lapsing of Amendment
Amendment L65

The Shire of Lillydale has resolved to abandon the above amendment.

The amendment proposed to rezone land at the south west corner of Harold Street and Mt Dandenong Tourist Road, Olinda, containing the property known as "The Mill", from Rural Landscape Living 2 to Restricted Use 7 (Tourist Accommodation).

The amendment lapsed on 30 October 1992.

GEOFF CODE
Manager
Planning Co-ordination Branch
Department of Planning and Development

ADOPTION ACT 1984

Under the functions and powers assigned to me by the secretary to the Department of Health and Community Services, under section 10 (2) of the *Community Services Act 1970* in relation to section 5 of the *Adoption Act 1984*, I, Karen Bodna approve the following person under section 5 (1) and 5 (2) (b) of the *Adoption Act* as approved counsellor for the purposes of section 87 of the *Adoption Act*.

McIntyre, Dawn
Dated 15 February 1993

KAREN BODNA
Assistant Director
Placement and Support Branch

ROADS CORPORATION

Commercial Passenger Vehicle and Tow Truck Applications

Notice is hereby given that the following applications will be considered by the Roads Corporation on 14 April 1993.

Notice of any objection to the granting of an application should be forwarded to reach the Section Leader, Vehicle Licensing or any District Office of the Roads Corporation not later than 8 April 1993.

It will not be necessary for interested parties to appear on the date specified, unless advised in writing by the Corporation.

Notification of the date for consideration of applications which are objected to and which require determination by the Road Transport Licensing Tribunal will be published by further notice in this Gazette.

K. Balabanis, Templestowe. Application to license two commercial passenger vehicles to be purchased in respect of 1991 or later model air conditioned Ford LTD sedans each with seating capacity for 4 passengers to operate as metropolitan hire cars from 15 Mintaro Court, Templestowe.

M. J. P. Bristow, Glen Iris. Application for variation of the conditions of licence MH 4406 which authorises the licensed vehicle to operate as a metropolitan hire car in respect of a 1955 or later model air conditioned Rolls Royce or Bentley sedan to change the vehicle to a 1988 or later model Ford stretched limousine with seating capacity for 7 passengers.

Note: This application is currently authorised by permit.

A. Caminiti, South Oakleigh. Application to license three commercial passenger vehicles to be purchased in respect of the following:

<i>Make</i>	<i>Year of Manufacture</i>	<i>Seating Capacity</i>
Cadillac sedan	1984	5
Cadillac sedan	1984	5
Cadillac stretched limousine	1984	11

to operate as metropolitan hire cars from 248 East Boundary Road, East Bentleigh.

A. Caminiti, South Oakleigh. Application to license two commercial passenger vehicles to be purchased in respect of the following:

<i>Make</i>	<i>Year of Manufacture</i>	<i>Seating Capacity</i>
Cadillac sedan	1960	5
Cadillac sedan	1961	5

to operate as special purpose vehicles from 248 East Boundary Road, East Bentleigh for the carriage of passengers for any of the following purposes:

- weddings
- debutante balls
- birthdays
- christenings
- engagements.

M. J. Cappelletti, Sunbury. Application to license one commercial passenger vehicle in respect of a 1989 Ford Fairlane sedan with seating capacity for 4 passengers to operate as a metropolitan hire car from 35 Elizabeth Street, Richmond.

R. de Cata, Reservoir. Application to license three commercial passenger vehicles in respect of the following:

<i>Make</i>	<i>Year of Manufacture</i>	<i>Seating Capacity</i>
Ford Falcon sedan	1969	4
Jaguar sedan (to be purchased)	1975 or later model	4
Jaguar sedan (to be purchased)	1975 or later model	4

to operate as special purpose vehicles from 75 Cuthbert Road, Reservoir for the carriage of passengers for any of the following purposes:

- weddings
- anniversaries
- parties
- engagements
- debutante balls.

J. C. Edwards, Bruthen. Application for variation of the conditions of licence SV 694 which authorises the licensed vehicle to operate tours of 1 to 7 days duration from Bairnsdale or Bruthen and charter conditions from within a 20 km pick-up radius of the Bruthen Post Office to include the ability to operate as follows—

- (i) using any of the following roads and tracks:
- Bairnsdale-Bulumwaal Road,
 - Bulumwaal-Mount Baldhead Road,
 - Bruthen-Mount Baldhead Road, Little Dick Range Road, Five Mile Spur Track, Seldom Seen Road, Wombargo Track, McFarlanes Flat Track,

Ingegoodbie Track, Berrima Creek, Deep Creek Road, Fire Break Road, Nicholson Creek Road, roads within Colquhoun State Forest (including Bruces Road Lakes Colquhoun and others), McKillops Bridge-Bonang Road, (Deddick River Road) and Bonang Highway; and

- (ii) tours to commence from:
Melbourne, Lilydale, Traralgon, Lakes Entrance, Metung and Swan Reach.

Note: Tours that commence in Melbourne passengers will be picked up/set down within a 5 km radius of the Melbourne GPO.

K. D. Gallagher, Wandana Heights. Application to license one commercial passenger vehicle to be purchased in respect of a 1993 Ford LTD sedan with seating capacity for 4 passengers to operate as an urban hire car from 27 James Cook Drive, Wandana Heights.

J. Kapolitsas and K. Kotsonis, Lalor. Application to license two commercial passenger vehicles to be purchased in respect of 1957 Chevrolet sedans each with seating capacity for 5 passengers to operate as metropolitan hire cars from 21 Kent Road, Lalor.

B. J. Street, Lalor. Application to license one commercial passenger vehicle in respect of a 1984 Jaguar sedan with seating capacity for 4 passengers to operate as a metropolitan hire car from 87 Kingsway Drive, Lalor.

G. R. Tate, Hallam. Application to license four commercial passenger vehicles in respect of one 1991 Harley Davidson motor cycle with seating capacity for 1 passenger and three 1986-93 Harley Davidson motor cycles (to be purchased) with seating capacity for 1 passenger and for passengers in a side car to its constructed seating capacity to operate as special purpose vehicles from 18 Eyebright Square, Hallam for the carriage of passengers for any of the following purposes:

- weddings
- parties
- sporting events
- parades
- promotions
- school socials
- debutante balls
- theatre nights
- restaurant nights
- tours to places of interest throughout the State of Victoria
- any other event similar to the above.

The Chauffeur (Aust) Pty. Ltd., Endeavour Hills. Application to license two commercial passenger vehicles to be purchased in respect of 1987 or later model Jaguar sedans each with seating capacity for 4 passengers to operate as metropolitan hire cars from 3 Belsize Court, Endeavour Hills.

Trackers Aboriginal Tours Pty Ltd, Bendigo. Application to license one commercial passenger vehicle to be purchased in respect of a 1990 Toyota coaster bus with seating capacity for 23 passengers to operate the following tours:

Tour 1—Duration 3 days

Depart Melbourne to Mount Kooyoora via Sunbury, Lancefield, Redesdale, Eppalock, Bendigo and Inglewood then return to Melbourne via the Calder Highway.

Tour 2—Duration 2 days

Depart Melbourne to Dhamya Education Centre, Barmah via the Calder Highway to Mount Macedon, Mount Alexander, Dja Dja Wrung Cultural Centre to Echuca/Moama to Barmah then return via Castlemaine, Mount Franklin, Woodend and Gisborne to Melbourne.

Fares: By agreement with the hirer.

Note: Passengers will be picked up/set down within a 5 km radius of the Melbourne GPO.

Dated 11 March 1993

MARGARET CUMMING
Section Leader—Vehicle Licensing

Transport Act 1983

ROADS CORPORATION

Commercial Passenger Vehicle Application
Amendment to Previous Notice

This notice corrects a previous notice which appeared in the *Victoria Government Gazette* No. 9 dated 4 March 1993 in the name of A. Barrett. Closing date for objections and the consideration date specified in that notice shall remain the same.

A. Barrett, North Coburg. Application to license one class 2 tow truck to be purchased to operate throughout the State of Victoria from a depot situated at 20 Roosevelt Street, North Coburg for the purpose of lifting and carrying or towing damaged or disabled motor cycles including the ability to attend the scene of a motor cycle accident in the 'Controlled Area'.

Dated 11 March 1993

MARGARET CUMMING
Section Leader—Vehicle Licensing

ELECTION OF ONE MEMBER OF THE
TRANSPORT SUPERANNUATION BOARD

Notice is hereby given in accordance with the Transport Superannuation Board Election Regulations 1988 that an election of a member of the fund to be appointed as a member of the Transport Superannuation Board for the period expiring on 31 March 1995 will be held on Friday, 7 May 1993.

Nominations for one member, under Regulation 4 (2) (c), will be received by the Returning Officer no later than twelve o'clock noon on Thursday, 25 March 1993.

Nomination forms may be obtained from Mr Roger Millar, Returning Officer, State Electoral Office, 6th Floor, 22 William Street, Melbourne.

IAN SMITH
Minister for Finance

Regulations
PORTARLINGTON FORESHORE RESERVE

Title

1. These Regulations may be cited as the Portarlington Foreshore Regulations 1992.

Objective

2. The objective of these Regulations is to provide for the care, protection and management of the Portarlington Foreshore Reserve.

Authorising provisions

3. These Regulations are made under section 13 of the *Crown Land (Reserves) Act 1978*.

Commencement

4. These Regulations come into operation on the date they are published in the *Victoria Government Gazette*.

Definitions

5. In these Regulations—

“Act” means the *Crown Land (Reserves) Act 1978*.

“Appointed Officer” means any person appointed in writing by the Committee as an appointed officer for the purposes of these Regulations and (except for the purpose of receipt of any fees or the grant, variation or revocation of any permit) also includes any members of the Police Force and any person appointed or deemed to be appointed an authorised officer under section 83 of the *Conservation, Forests and Lands Act 1987*.

“Camp” means—

(a) to erect, occupy or use any tent; or

(b) to park occupy or use any caravan, campervan or other moveable form of accommodation.

“Camping Area” means any part of the reserve set apart as a site for camping purposes.

“Committee” means the Committee of Management appointed to manage the reserve under section 14 of the Act.

“Firearm” includes any rifle, gun, pistol, air gun, catapult, bow and arrow, crossbow or any weapon or other implement designed to discharge a missile and capable of injuring, damaging or destroying any person, animal or thing.

“Litter” includes any bottle, carton, package, paper, glass, food, offal, animal carcass, vegetable matter or other refuse or rubbish.

“Permit” includes any authority, approval, consent, permission, receipt, ticket or the like given, granted or issued by the Committee or an appointed officer under these Regulations.

“Reserve” means the Crown lands in the Township of Portarlington reserved for various purposes and shown by red colour on plan marked P/30.11.88 attached to the Department of Conservation and Environment Correspondence No. Rs 6395.

“Vehicle” includes any motor car, motor cycle, bus, truck, bicycle, skateboard, cart, horse-drawn vehicle, caravan, trailer or water craft.

Part 1—Powers, Functions and Duties of the
Committee

6. (1) Except as provided in these Regulations the reserve is open to the public free of charge.

(2) The Committee may determine, in either general or specific terms, the times and days on which the whole or any part of the reserve will not be available for use by the public.

(3) The Committee may enclose or set aside for a particular activity the whole or any part of the reserve and may include in that determination, conditions or restrictions relating to the use by the public of that area.

(4) The Committee may determine the conditions of entry or use of any conveniences, facilities or amenities of any description in any part of the reserve.

(5) The particulars of any determination made under this Part must be displayed where they are reasonably likely to be seen by persons likely to be affected by them.

Part 2—Permits

7. (1) The Committee or an appointed officer may at its discretion grant permits for—
- (a) the use by any person, club or association of any area enclosed or set aside for a particular purpose or activity under these Regulations;
 - (b) the admission and entry to the Reserve or any part thereof; or
 - (c) any other purpose for which a permit is required under these Regulations.
- (2) The Committee may—
- (a) determine the conditions of any permit granted under these Regulations; and
 - (b) determine, impose, collect and receive tolls, fees, rents or other charges for or in respect to—
 - (i) the admission or entry to or parking of vehicles within the Reserve; and
 - (ii) any other permit granted pursuant to sub-regulation 7 (1) (c).
- (3) No permit shall be transferable.
- (4) Any permit may be revoked or withdrawn at the discretion of the Committee.
- (5) Any person purporting to hold any permit shall produce the same on demand by any appointed officer and unless such permit is thereupon produced that person shall not be entitled to claim the benefit of any such permit.

Part 3—Offences

8. Within the Reserve a person must not—
- (a) behave in a noisy or disorderly manner or create or take part in any disturbance or commit any act of indecency or offend against decency as regards dress, language or conduct;
 - (b) commit or create or knowingly permit or allow to continue any public or private nuisance, or any annoyance to the public or any persons lawfully in the Reserve which may interfere with the quiet enjoyment of the Reserve by any other person;
 - (c) roll or throw any stone or other substance within the Reserve which is likely to damage property or endanger or annoy other persons lawfully using the Reserve;
 - (d) ride, drive or lead any horse or allow any horse to swim except within an area set aside for that purpose and

Victoria Government Gazette

subject to any conditions determined by the Committee;

- (e) except in an area set aside for that purpose play any game in which a hard ball is used;
- (f) engage in any game, sport or entertainment likely to cause inconvenience, annoyance or danger to any other person using the Reserve;
- (g) leave any litter except in a receptacle provided for that purpose;
- (h) bring into the Reserve and deposit or allow to remain any domestic or household waste, car body, building material or other waste;
- (i) break any glass bottle or other container within the Reserve and in the event of so doing shall immediately gather up the pieces and remove them or place them in a receptacle provided for litter;
- (j) use any kitchen, laundry, change-room, shower, toilet or other convenience or any part thereof in the Reserve except for its proper purpose and upon payment of such fees (if any) as may be prescribed in any permit;
- (k) enter or use or permit any child under their care or control to enter or use any place, room, convenience or structure set apart for the use of the opposite sex, provided that this Regulation shall not apply to a child under the age of six years when accompanied by an adult of the opposite sex;
- (l) except for a dog that is used by a blind person as a guide dog bring into or permit to remain a dog—
 - (i) which is not controlled by means of a leash or other form of restraint and is effectively restrained from causing annoyance to any person and from damaging or interfering in any way with any property in the Reserve; or
 - (ii) in any camping area or in any portion of the Reserve prohibited to the entry of dogs and indicated by notices.
- (m) park any vehicle except—
 - (i) in an area set apart for that purpose and clearly defined by signs;
 - (ii) as and where directed by an appointed officer; and

- (iii) upon payment of such fees (if any) as may be determined.
 - (n) by driving any vehicle deliberately damage any vegetation or unduly interfere with any sand, stone, gravel, rock, clay or earth;
 - (o) drive any vehicle in a manner dangerous to the public;
 - (p) drive any vehicle so as to cause noise which is unreasonable in the circumstances;
 - (q) drive any vehicle of a speed greater than that indicated by any sign or notice;
 - (r) obstruct, hinder or interfere with any appointed officer or any employee of the Committee in the execution of their duties;
 - (s) remain when lawfully directed to leave by an appointed officer; or
 - (t) refuse to give their name and address, or gives a false name and address when lawfully requested to do so by an appointed officer;
 - (u) launch a boat except in an area set aside for that purpose and upon payment of such fees (if any) as may be determined;
 - (v) use a beach umbrella or similar device for providing shade or protection unless it is securely anchored—
 - (i) by means of a disc of weather-proof plywood at least 300 mm in diameter fitted over the shaft and immediately above the tip and the disc buried in the sand to a depth of at least 300 mm; or
 - (ii) by means of bag filled with at least 8 kilograms dry weight of sand securely tied to the shaft at ground level; or
 - (iii) by means of a device with an equivalent effect to an anchoring device referred to in paragraphs (i) or (ii).
9. Within the reserve a person must not without first obtaining a permit—
- (a) shoot, trap, maim, injure, kill or destroy any bird or animal;
 - (b) carry or use any firearm, poison, trap or snare;
 - (c) remove, cut, damage, displace, deface or interfere with any rock, timber, tree, shrub, plant, wildflower or other vegetation or any sign, noticeboard, seat, table, gate, post, fence, bridge, building, structure or any other thing of a like nature;
 - (d) dig up or remove from or bring into the Reserve any gravel, stone, shell-grit, sand, soil, loam or seaweed;
 - (e) drive, ride, push, pull, place or leave any vehicle in or on the Reserve except in or upon such roadways or areas as are set aside for the purpose and no person shall allow any vehicle to remain stationary in any position where it may cause undue or unreasonable obstruction to the lawful passage of others;
 - (f) sell or offer for sale any article whatsoever;
 - (g) give out, distribute, erect, leave set up or display any handbill, placard, notice, pamphlet, book, paper, advertising matter or any like thing;
 - (h) occupy, use or enter any building, booth, shed, stand or enclosure unless the same is set aside for public use;
 - (i) erect or place therein any building, booth, shed or other structure;
 - (j) solicit or collect money or orders for goods or services;
 - (k) take part in or advertise any entertainment for gain;
 - (l) preach, declaim, harangue or deliver any address of any kind or use any amplifier, public address system, loud hailer or similar device;
 - (m) offer for hire any article, device or thing;
 - (n) take photographs for gain or commercial purposes;
 - (o) ply a vehicle for hire or carry any passengers for fee or reward;
 - (p) conduct any school or provide any form of instruction for gain;
 - (q) advertise for sale or trade or hire any article, device, service or thing;
 - (r) disturb, interfere with or destroy any animal or bird or its lair or nest;
 - (s) operate any portable or stationary generator, air-compressor or chainsaw;
 - (t) except as provided in these Regulations or in any determination made by the Committee bring into or permit to remain any animal;

- (u) enter any area in the reserve which is enclosed for the plantation of young trees, shrubs or grass plots or for the rehabilitation or preservation of native flora or any other purpose;
- (v) light, maintain or use a fire in the reserve except in a portable barbeque or in a fireplace provided by the Committee. Any person who lights a fire in the reserve shall take all reasonable and proper precautions to ensure that the fire does not escape from control or damage anything growing or being on the reserve;
- (w) wilfully or carelessly do, make or permit any act or omission which may result in or be likely to result in damage by fire to anything growing or being on the reserve.

Part 4—General

10. An appointed officer may direct any person who in his or her opinion offends against these Regulations to leave the reserve or any place therein.

11. If, in the opinion of an appointed officer, any person has contravened or failed to comply with any provision of these regulations then the officer may demand the name and address of the person.

12. An appointed officer may remove or cause to be removed any parked, stranded or broken-down vehicle from any roadway or area within the reserve provided that the removal of any vehicle—

- (a) shall be at the sole risk of the owner of the vehicle who shall be deemed to have accepted such risk as a condition of entry to the reserve; and
- (b) may be effected in such manner as the appointed officer deems fit.

13. Any vehicle left unattended within the reserve for a continuous period exceeding forty-eight hours may be removed by the Committee at the risk and expense of the owner.

14. (1) If, in the opinion of an appointed officer a tent or any temporary, make-shift form of accommodation has been erected without a permit the officer may remove such tent or temporary, make-shift accommodation and take it to a place of safe keeping.

(2) If a tent or temporary make-shift accommodation is removed in accordance with

regulation 14 (1) the appointed officer effecting such removal shall leave a notice of removal at the site of removal indicating to the owner the place where such tent or temporary make-shift accommodation can be collected.

15. Any person who contravenes or fails to comply with any provisions in these regulations is guilty of an offence and liable for the penalties prescribed in section 13 of the *Crown Land (Reserves) Act 1978*.

Revocation of Existing Regulations

16. The Portarlington Foreshore regulations made on 31 January 1989 and 16 July 1990 published in the *Victoria Government Gazette* on 6 February 1989 and 18 July 1990 are hereby revoked.

Dated 2 February 1993

MARK BIRRELL

Minister for Conservation and Environment

MELBOURNE WATER

Proclamation of Water Mains

Notice to the owners of tenements in the undermentioned street and the private streets, lanes, courts, and alleys opening thereto. The main pipe in the said streets being laid down, the owners of all tenements situated as under are hereby required on or before 12 April 1993 to cause a proper pipe and stop-cocks to be laid so as to supply water within such tenements from the main pipe.

CRANBOURNE

Cadles Road, from the southwest boundary of Lot 1, northward 56 metres.

Carrum Woods Drive, from the southeast boundary of Lot 57 southward, then eastward, then southward 392 metres.

St. Andrews Close, the whole Close 61 metres.

Sims Court, the whole Court 77 metres.

Atkins Court, the whole Court 77 metres.

Griffith Place, from Carrum Woods Drive, northward 42 metres.

Tolga Close, the whole Close 142 metres.

Sherbourne Drive, from Cadles Road, westward 83 metres.

Bradford Drive, from Sherbourne Drive, southward 80 metres.

Barretts Road, 6 metres south of the southeast boundary of Lot 15, southward 57 metres.

Marshall Close, the whole Close 62 metres.

Amanda Close, from Jacana Drive, northward, then westward 90 metres.

Jacana Drive, 140 metres north of O'Grady's Road, northward then eastward 128 metres.

Donna Street, from Jacana Drive, westward 45 metres.

FRANKSTON

The Helm, 220 metres north of Somerset Road, northward 57 metres.

Fletcher Street, from Nepean Highway, eastward 141 metres.

Brushwood Grove, the whole Grove 132 metres.

Saltbush Glade, the whole Glade 109 metres.

HASTINGS

Briar Close, 35 metres west of the southeast boundary of Lot 42, eastward, then southward 138 metres.

Oakbank Court, the whole Court 116 metres.

Eramosa Road West, from the southeast boundary of Lot 1, generally eastward 196 metres.

Wattle Court, the whole Court 78 metres.

Clairmont Close, from Eramosa Road West, northward, then westward, then northward 390 metres.

Clairmont Close, 6 metres west of the northeast boundary of Lot 2, northward, then eastward 24 metres.

SPRINGVALE

Hilda Mews, the whole Mews 97 metres.

Rochelle Court, the whole Court 148 metres.

Merthyr Place, the whole Place 156 metres.

Wildoer Drive, from Branagan Drive, northeastward, then northwestward 283 metres.

Branagan Drive, from the northwest boundary of Lot 40, generally southeastward 163 metres.

Further particulars may be obtained from Melbourne Water's, Technical Services Supervisor, Telephone 552 3334, Moorabbin Office, South East Region.

By Order of

MATTHEW GIESEMANN
Development Manager
South East Region

VARIATION OF FIRE DANGER PERIOD

In pursuance of the powers conferred by section 4 of the *Country Fire Authority Act 1958*, I, Leonard Raymond Foster, Chairman of the Country Fire Authority, after consultation with the Secretary of Conservation and Natural Resources, hereby vary the declaration of Fire Danger Periods previously published in the *Government Gazette* by declaring that such Fire Danger Periods shall end in respect of the undermentioned municipalities or parts of municipalities specified.

To terminate from 0100 hours on Monday, 15 March 1993:

Shire of Bacchus Marsh; Shire of Melton; Shire of Newman and Woodend; City of Whittlesea (those portions not included in the Metropolitan Fire District); City of Werribee (those portions not included in the Metropolitan Fire District); Shire of Bulla (those portions not included in the Metropolitan Fire District); City of Sale; City of Morwell; Shire of Avon; Shire of Rosedale; Yallourn Works Area; Shire of Bright; Shire of Myrtleford; Shire of Upper Murray; Rural City of Wodonga; Shire of Alexandra; Shire of Mclvor; Shire of Seymour; City of Colac; Town of Camperdown; Shire of Heytesbury; Shire of Mansfield; City of Benalla; City of Bendigo, Rural City of Marong; Shire of Bet Bet; Shire of Huntly; Shire of Metcalfe; City of Bairnsdale; Shire of Tambo; Shire of Gisborne; Shire of Romsey; Shire of Kilmore; City of Traralgon; Shire of Alberton; Shire of Maffra; Shire of Traralgon; United Shire of Beechworth; Shire of Chiltern; Shire of Tallangatta; Shire of Yackandandah; Shire of Arapiles; Shire of Broadford; Shire of Pyalong; Shire of Yea; Shire of Hampden; Shire of Colac; Shire of Otway; Shire of Benalla; Shire of Mortlake; City of Castlemaine; Borough of Eaglehawk; Shire of East Loddon; Shire of Korong; Shire of Strathfieldsaye; Shire of Bairnsdale.

To terminate from 0100 hours on Monday, 22 March 1993:

Town of St. Arnaud; Shire of Maldon; Shire of Kara Kara; Shire of Orbost.

L. FOSTER
Chairman

504 G 10 11 March 1993

STATE TENDER BOARD
CONTRACTS ACCEPTED
Amendments

Schedule Number	Item Number	New Rate	Effective Date
		\$	
<i>Paper Products</i>			
1/17	1.0A	28.39	1.3.93
	1.0B	28.39	
	2.0	30.06	
	3.0	30.46	
	4.0	30.72	
	5.0	30.99	
	6.0	31.38	
	13.0A	30.20	
	13.0B	31.92	
	14.0	32.35	
	15.0	32.65	
	16.0	32.94	
	17.0	33.37	
<i>Fasteners</i>			
1/26	2	Ajax 2/93	22.3.93
	4	List Less 80%	
	5	Ajax 2/93	
	6	List Less 55%	
	7	Ajax 2/93	
	8	List Less 85%	
	10, 11	Ajax 2/93	
	12, 14	List Less 80%	
	16, 19	Ajax 2/93	
	26	List Less 76%	
	27	Ajax 2/93	
	28	List Less 68%	
	29	Ajax 2/93	
	31	List Less 80%	
	32	Ajax 2/93	
	34	List Less 85%	
	35	Ajax 2/93	
	36	List Less 80%	
	37	Ajax 2/93	
	39	List Less 68%	
	40	Ajax 2/93	
	41	List Less 68%	
<i>Motor Spirit, Fuel Oils, Kerosene and Lubricants</i>			
1/53	1	0-5544	1.3.93

Victoria Government Gazette

Schedule Number	Item Number	New Rate	Effective Date
	2	0-5552	
	3	0-5624	
	4	0-5632	
	12	0-5824	
	13	0-5832	
	<i>Tyres and Tubes (Pneumatic)</i>		
1/57	6	*	3.8.93
	* Goodyear Trade Price List T79 1.8.93 Less 43-5% not 57% as gazetted.		
	<i>Motor Vehicles (Passenger)</i>		
1/58	15.0	16 782.00	2.3.93
	16.0	17 162.00	
	17.0	18 042.00	
	18.0	18 423.00	
	<i>Options Available—</i>		
	Air conditioning	1 126.00	
	Tow pack (man.)	127.00	
	Tow pack (auto.)	255.00	
	Metallic paint	136.00	
	Limited slip diff	302.00	
	Heavy duty suspension	161.00	
		19.0 21 895.00	
		20.0 25 831.00	
		20.1 26 720.00	
	<i>Options Available—</i>		
	Limited slip diff	302.00	
	Tow pack (auto.)	255.00	

N. L. JORDAN
Secretary to the Tender Board

STATE TENDER BOARD

Tenders will be received until 8.30 a.m. on Friday, 26 March 1993 for:

Supply of General Stores—

- 1/01—Disinfectants, deodorants and detergents
- 1/04—Cleaning supplies (brooms, brushes, clothes, mops and steel wool)
- 1/05—Electrical goods (appliances, cables and accessories)
- 1/06—Fire protection equipment, fire extinguishers, etc.
- 1/07—Buckets, rubbish bins and garbage bags
- 1/09—Floor polishes
- 1/10—Industrial gases (in cylinders)

Victoria Government Gazette

- 1/12—Painters' brushware, rollers and signwriters' pencils
1/13—Paints and painters' sundries
1/15—Soaps, soap mixtures and cleansers
1/16—Toilet requirements (toothbrushes and toothpaste)

for the period 1 July 1993 to 30 June 1995.

Details obtainable from State Tender Board,
1/555 Collins Street, Melbourne 3000. Phone:
616 8666 Fax.: 616 8660.

Co-operation Act 1981

DAYLESFORD TRADING CO-OPERATIVE
LIMITED
GROVEDALE SPORTS CLUB
CO-OPERATIVE LIMITED
ILUKA CO-OPERATIVE SOCIETY
LIMITED
MORDIALLOC 12 SQUARE METRE
SAILING CLUB CO-OPERATIVE LIMITED
PINWOOD TENNIS CLUB
CO-OPERATIVE SOCIETY LIMITED
VERMONT HIGH SCHOOL
CO-OPERATIVE LIMITED

Notice is hereby given in pursuance of section 192 (8) of the *Co-operation Act 1981* and section 572 (2) of the *Corporations Act 1989* that, at the expiration of three months from the date hereof, the names of the aforementioned societies will, unless cause is shown to the contrary, be struck off the register and the societies will be dissolved.

Dated at Melbourne 24 February 1993

D. F. HENRY
Deputy Registrar of Co-operatives

Co-operation Act 1981

NEERIM SOUTH HIGH SCHOOL
CO-OPERATIVE LIMITED
TARGAN SKI CO-OPERATIVE LIMITED
TYABB ROAD MORNINGTON TABLE
TENNIS CO-OPERATIVE LIMITED
YURREDLA SKI CO-OPERATIVE LIMITED
Notice of Dissolution of Societies

Notice is hereby given that I have this day registered the dissolution of the abovenamed societies and cancelled their registration under the abovenamed Act.

Dated at Melbourne 24 February 1993

D. F. HENRY
Deputy Registrar of Co-operatives

G 10 11 March 1993 505

INDUSTRIAL AND PROVIDENT
SOCIETIES ACT 1958

Notice is hereby given that registration of the following societies was cancelled under the provisions of the above Act on 19 February 1993:

Koroit and Tower Hill Farmers Co-
operative Society Limited
Australian Labor Trust Society Limited
G & D Industrial Benefit Society Limited
Earthmovers Mutual Provident Society
Limited
AFSIS Limited

DAVID LAFRANCHI
Delegate of the Victorian Financial
Institutions Commission

DELEGATION OF AUTHORITY

Under the *Freedom of Information Act 1982*
(Section 26)

Royal Botanic Gardens Board
General Authority

The officer occupying for the time being (whether on a permanent, acting or temporary basis) the position of Records Manager in the Royal Botanic Gardens Board is authorised to make all necessary decisions on behalf of the Board, in order to comply with and give effect to the provisions of the Freedom of Information Act in respect of requests made to the Board. Any previous notice of authorisation of this position is hereby revoked.

Dated 25 February 1993

Dr P. J. MOORS
Principal Officer
Director, Royal Botanic Gardens

Stamps Act 1958

NOTICE UNDER SECTION 40A

Pursuant to section 40A of the *Stamps Act 1958*, I hereby declare National Australia Bank of 271 Collins Street, Melbourne to be an "authorised person" (No. AP-161) in relation to the stamping of Registered Mortgage Debentures, Mortgages and Letters of Lien to which section 137D of Subdivision (17) of Division 3 of Part II of the *Stamps Act 1958* applies.

ALAN STOCKDALE
Treasurer

506 G 10 11 March 1993

Stamps Act 1958

NOTICE UNDER SECTION 40A

Pursuant to section 40A of the *Stamps Act* 1958, I hereby declare St George Bank Limited of 95 Queen Street, Melbourne to be an "authorised person" (No. AP-157) in relation to the stamping of Mortgages and Variations of Mortgage to which section 137b of Subdivision (17) of Division 3 of Part II of the *Stamps Act* 1958 applies.

ALAN STOCKDALE
Treasurer

Legal Profession Practice Act 1958
SOLICITORS' (PROFESSIONAL
CONDUCT AND PRACTICE)
(AMENDMENT No. 1) RULES 1993

In the pursuance of the powers conferred by the *Legal Profession Practice Act* 1958 and all other powers thereunto enabling the Council of the Law Institute of Victoria hereby makes the following Rules:

1. These Rules may be cited as the Solicitors' (Professional Conduct and Practice) (Amendment No. 1) Rules 1993 and shall come into operation on the date of their publication in the *Victoria Government Gazette*.

2. The Solicitors' (Professional Conduct and Practice) Rules 1984 are in these Rules referred to as the Principal Rules.

3. Rule 10 of the Principal Rules is amended as follows:

Sub-Rule (6) is repealed and the following is substituted—

"(6) Notwithstanding anything contained in sub-rule (2) a solicitor shall not act:

(a) in connection with a loan of money or an agreement to lend money:

(i) for a borrower and a lender held out to the public as being in the business of lending other than a bank, a trustee company as defined in the *Trustee Companies Act* 1984, a Solicitors' Mortgage Investment Company, a building society, a credit union, a credit co-operative or a housing co-operative society; or

(ii) for a borrower or lender and a guarantor, indemnifier, surety or mortgagor who/which was not:

(x) A borrower;

Victoria Government Gazette

(y) a director or shareholder of a borrower; or

(z) a related body corporate (as defined under the Corporations Law) of a borrower; or

(b) for a person or entity carrying on business as a builder, developer or subdivider and any other party contracting with that person or entity in any property related matter or transaction in the course of that business".

Dated 2 March 1993

Signed for and on behalf of the Council of the Law Institute of Victoria.

GORDON HUGHES

President

ROBERT CORNALL

Secretary

I approve the above Rules.

Dated 3 March 1993

JOHN HARBER PHILLIPS

Chief Justice

Notice to Creditors, next of kin and others having claims against the estate of any of the under-mentioned deceased persons are required to send particulars of their claims to the State Trust Corporation of Victoria, 168 Exhibition Street, Melbourne Vic. 3000, the personal representative, on or before 10 May 1993, after which date the State Trust Corporation may convey or distribute the assets having regard only to the claims of which the State Trust Corporation then has notice:

De Baere, Jean, formerly of Flat 6, 34 Leslie Street, Richmond, late of St. Catherines House, 1 Clayton Road, Balwyn, home duties, died 19 December 1992.

Duggan, Henry Adolphus, late of 39 Reid Street, North Fitzroy, retired plasterer, died 24 October 1992.

Eiherton, Allan Ross, also known as Alan Ross Eiherton, late of 169 Greensborough Road, Macleod, pensioner, died 19 December 1992.

Ford, Robert Edward, late of Colac, pensioner, died 5 June 1992.

McDonald, Doris Allison, late of 31 Eulinga Road, Clarinda, retired, died 8 December 1992.

Mitchell, Nellie Veronica, late of Rosanna Lodge, 3 Lower Plenty Road, Rosanna, widow, died 8 April 1991.

Victoria Government Gazette

Rundle, Gerald Pringle, late of Mermaid Beach Nursing Home, 2424 Gold Coast Highway, Mermaid Beach, Queensland, pensioner, died 15 January 1993.

Dated at Melbourne 1 March 1993

B. F. CARMODY
Managing Director
State Trust Corporation

Notice to Creditors, next of kin and others having claims against the estate of any of the under-mentioned deceased persons are required to send particulars of their claims to the State Trust Corporation of Victoria, 168 Exhibition Street, Melbourne Vic. 3000, the personal representative, on or before 10 May 1993, after which date the State Trust Corporation may convey or distribute the assets having regard only to the claims of which the State Trust Corporation then has notice:

Bozic, Danica, also known as Danka Bozic, late of 151/95 Napier Street, Fitzroy, pensioner, died 19 July 1992.

Carrodus, Lillian Mary, late of Mount Royal Lodge, Poplar Road, Parkville, retired, died 18 December 1992.

Christie, Victor Hugh Trevlyn, late of 29 Selby Aura Road, Menzies Creek, retired, died 5 November 1992.

Evans, John Reginald, late of Greenhaven Special Accommodation House, 290A Geelong Road, Footscray, retired, died 26 November 1992.

Ford, Philippa Elliot, late of 5 Nola Court, Croydon, married woman, died 9 December 1992.

Kean, Mary, late of Vincenpaul Hostel, 13 Strabane Avenue, Box Hill North, spinster, died 20 January 1993.

Kunack, Anthony, late of 72 Young Street, Fitzroy, pensioner, died 15 October 1992.

Leslie, Leonard George, late of Benlynne Park Private Nursing Home, 2 Killara Street, West Sunshine, pensioner, died 25 October 1992.

Lyell, Frederick James, late of 26 Lawrence Street, Blackburn, technical officer, died 13 December 1992.

Milward, Florence Maud, late of 471 Brunswick Road, West Brunswick, widow, died 9 November 1992.

Moon, Ralph, late of 12/43-47 Chapel Road, Moorabbin, died 26 December 1992.

G 10 11 March 1993 507

O'Connor, Jean Mary, late of 61 Barrett Street, Albert Park, widow, died 6 December 1992.

Oliver, Joseph Gordon, late of 119 Collins Street, Thornbury, retired, died 8 August 1992.

Rozen, Abraham, formerly of Flat 8, 19 Snowden Avenue, Caulfield, late of 619 St. Kilda Road, Melbourne, gentleman, died 29 June 1992.

Walsh, Mary Ellen, late of "Wahroonga" Matong, New South Wales, widow, died 17 May 1943.

Dated at Melbourne 1 March 1993

B. F. CARMODY
Managing Director
State Trust Corporation

*Land Acquisition and Compensation Act 1986
and Transport Act 1983*

NOTICE OF ACQUISITION

Compulsory Acquisition of Interest in Land
The Roads Corporation declares that by this notice it acquires the following interest in the land described hereunder:

Owners' Names: Mr Antonio Smaniotto and Mrs Assunta Smaniotto.

Description of Interest in Land: Being part of the land in Plan of Consolidation No. 157946M and being part of Crown Allotments 68 and 69, Parish of Moe.

Area: 8729 square metres.

Title Details: Land contained in Certificate of Title Volume 9568 Folio 498.

Survey Plan No.: 18449 (parcel 5).

The survey plan referred to in this notice may be viewed at Property Services, Vic Roads, 3 Prospect Hill Road, Camberwell.

Published with the authority of the Roads Corporation and the Minister for Transport.

DEREK TREWARNE
Manager Property Operations
Roads Corporation

*Land Acquisition and Compensation Act 1986
and Transport Act 1983*

NOTICE OF ACQUISITION

Compulsory Acquisition of Interest in Land
The Roads Corporation declares that by this notice it acquires the following interest in the land described hereunder:

Owner's Name: Mr Bernard Joseph Smaniotto.

508 G 10 11 March 1993

Description of Interest in Land: Being part of Crown Allotment 68, Parish of Moe.

Area: 4300 square metres.

Title Details: Land contained in Certificate of Title Volume 9655 Folio 911.

Survey Plan No.: 18449 (parcel 4).

The survey plan referred to in this notice may be viewed at Property Services, Vic Roads, 3 Prospect Hill Road, Camberwell.

Published with the authority of the Roads Corporation and the Minister for Transport.

DEREK TREWARNE
Manager Property Operations
Roads Corporation

Land Acquisition and Compensation Act 1986 and Transport Act 1983

NOTICE OF ACQUISITION

Compulsory Acquisition of Interest in Land

The Roads Corporation declares that by this notice it acquires the following interest in the land described hereunder:

Owners' Names: E. M., I. W. and B. A. Ashby, executors of the estate of E. Ashby.

Description of Interest in Land: Being part of Crown Allotment 67B, Parish of Moe.

Area: 1.017 hectares.

Title Details: Land contained in Certificate of Title Volume 3999 Folio 713.

Survey Plan No.: 18449 (parcel 3).

The survey plan referred to in this notice may be viewed at Property Services, Vic Roads, 3 Prospect Hill Road, Camberwell.

Published with the authority of the Roads Corporation and the Minister for Transport.

DEREK TREWARNE
Manager Property Operations
Roads Corporation

Land Acquisition and Compensation Act 1986 and Transport Act 1983

NOTICE OF ACQUISITION

Compulsory Acquisition of Interest in Land

The Roads Corporation declares that by this notice it acquires the following interest in the land described hereunder:

Owners' Names: Mr Jeffrey Douglas Hasthorpe and Mrs Vicki Narel Hasthorpe.

Description of Interest in Land: Being part of Crown Allotment 67B, Parish of Moe.

Area: 4131 square metres.

Victoria Government Gazette

Title Details: Land contained in Certificate of Title Volume 9519 Folio 051.

Survey Plan No.: 18449 (parcel 2).

The survey plan referred to in this notice may be viewed at Property Services, Vic Roads, 3 Prospect Hill Road, Camberwell.

Published with the authority of the Roads Corporation and the Minister for Transport.

DEREK TREWARNE
Manager Property Operations
Roads Corporation

Land Acquisition and Compensation Act 1986 and Transport Act 1983

NOTICE OF ACQUISITION

Compulsory Acquisition of Interest in Land

The Roads Corporation declares that by this notice it acquires the following interest in the land described hereunder:

Owners Names: Mr Laurence Sydney Davey and Mr Raymond Arthur Davey.

Description of Interest in Land: Being part of Lot 1 on Plan of Subdivision No. 212304N, Parish of Moe.

Area: 1.443 hectares.

Title Details: Land contained in Certificate of Title Volume 9833 Folio 838.

Survey Plan No.: 18449 (parcel 1).

The survey plan referred to in this notice may be viewed at Property Services, Vic Roads, 3 Prospect Hill Road, Camberwell.

Published with the authority of the Roads Corporation and the Minister for Transport.

DEREK TREWARNE
Manager Property Operations
Roads Corporation

Land Acquisition and Compensation Act 1986 and Transport Act 1983

NOTICE OF ACQUISITION

Compulsory Acquisition of Interest in Land

The Roads Corporation declares that by this notice it acquires the following interest in the land described hereunder:

Lessee's Name: Italo-Australian Co-Operative Social Club Ltd.

Description of Interest in Land: Leasehold interest in part of Lot 2 on Plan of Subdivision No. 300897A, Parish of Maribymong.

Area: 1.12 hectares.

Title Details: Part of land contained in Certificate of Title Volume 10000 Folio 859.

Victoria Government Gazette

A plan of the land referred to in this notice may be viewed at Property Services Department, Vic Roads, 2nd Floor, 3 Prospect Hill Road, Camberwell.

Published with the authority of the Roads Corporation and the Minister for Transport.

DEREK TREWARNE
Manager, Property Operations
Roads Corporation

Department of Finance
SALE OF CROWN LAND BY PUBLIC
AUCTION

Reference No. GL15581

On Saturday, 3 April 1993 at 11.00 a.m. on site.

Address of Property: Stony Point Road, Crib Point.

Crown Description: Crown Allotments 1, 3, 4, 7, 8, 11, 12, and 15, Section 1, Township of Crib Point, Parish of Bittern.

Terms of Sale: Deposit 10%, balance 60 days.

Officer Co-ordinating Sale: Militsa Toskovska, Property Consultant, Asset Management Division, Department of Finance, 4/35 Spring Street, Melbourne 3000.

Selling Agent: Crowders Real Estate, 69 High Street, Hastings 3915.

IAN SMITH
Minister for Finance

Department of Finance
SALE OF CROWN LAND BY PUBLIC
AUCTION

Reference No. GL/17510

On Saturday, 1 May 1993, at 11.00 a.m. on site.

Address of Property: Bell-Bennett Streets, Bendigo.

Crown Description: Crown Allotments 414C, 414D and 414E, Section K, Parish of Sandhurst at Bendigo (to be sold separately).

Terms of Sale: Deposit 10%, balance 60 days.

Area: Crown Allotment 414C: 6654m²; Crown Allotment 414D: 1436m²; Crown Allotment 414E: 1800m².

Officer Co-ordinating Sale: Mr Paul Ramage, Property Consultant, Asset Management Division, Department of Finance. Telephone (03) 651 3324.

G 10 11 March 1993 509

Selling Agent: Ellis Nuttall & Co., 92 Queen Street, Bendigo 3550.

IAN SMITH
Minister for Finance

Department of Finance
SALE OF CROWN PROPERTY BY PUBLIC
AUCTION

Reference No. GL13601

On Saturday, 17 April 1993 at 10.30 a.m. on site:

Address of Property: Raichards Road, Calivil.

Crown Description: Crown Allotment 53e No Section Parish of Calivil.

Terms of Sale: Deposit 10%, balance 60 days.

Area: 1948 m².

Officer Co-ordinating Sale: Janice Rogan, Property Consultant, Asset Management Division, Department of Finance, 4/35 Spring Street, Melbourne 3000.

Selling Agent: Gippsland & Northern Real Estate, 15 Gillies Street, Rochester 3561.

IAN SMITH
Minister for Finance

Shop Trading Act 1987
ORDER GRANTING APPLICATION TO
PERMIT SHOPS OUTSIDE THE
METROPOLITAN AREA TO BE OPEN ON
A SUNDAY

Whereas—

- (i) I am the Minister for the time being administering the *Shop Trading Act 1987*;
- (ii) Sunday, 4 and 18 April 1993 and Sunday, 2 May 1993 are days on which a shop in the metropolitan area is permitted to be open under section 7A of the *Shop Trading Act 1987*; and
- (iii) the municipal councils of the municipal districts listed in the schedule hereto have made application to me for an Order permitting shops in their respective municipal districts to be open between the hours of 10.00 a.m. and 5.00 p.m. on Sunday, 4 and 18 April 1993 and Sunday, 2 May 1993.

Now therefore I, Vin Heffernan, acting pursuant to the power conferred upon me by section 7B (2) of the *Shop Trading Act 1987* by this Order grant this application.

510 G 10 11 March 1993

Victoria Government Gazette

SCHEDULE

<i>Name of Applicant Municipal Council</i>	<i>Municipal District</i>
Shire of Broadford	Shire of Broadford
Shire of Heytesbury	Shire of Heytesbury

Dated 4 March 1993

VIN HEFFERNAN
Minister for Small Business

Shop Trading Act 1987
ORDER GRANTING APPLICATION TO
PERMIT SHOPS OUTSIDE THE
METROPOLITAN AREA TO BE OPEN ON
A SUNDAY

Whereas—

- (i) I am the Minister for the time being administering the *Shop Trading Act 1987*;
- (ii) Sunday, 18 April 1993 is a day on which a shop in the metropolitan area is permitted to be open under section 7A of the *Shop Trading Act 1987*; and
- (iii) the municipal council of the municipal district listed in the schedule hereto has made application to me for an Order permitting shops in its municipal district to be open between the hours of 10.00 a.m. and 5.00 p.m. on Sunday, 18 April 1993.

Now therefore I, Vin Heffernan, acting pursuant to the power conferred upon me by section 7B (2) of the *Shop Trading Act 1987* by this Order grant this application.

SCHEDULE

<i>Name of Applicant Municipal Council</i>	<i>Municipal District</i>
City of Morwell	City of Morwell
Shire of Woorayl	Shire of Woorayl

Dated 4 March 1993

VIN HEFFERNAN
Minister for Small Business

APPOINTMENTS

**APPOINTMENT OF HONORARY
PROBATION OFFICERS**

I, Lynne Jordan, Acting Regional Director of Loddon-Mallee Region of Health and Community Services, under section 34 (4) of the *Children and Young Persons Act 1989* appoint the undermentioned persons as Honorary Probation Officers for the Children's Court in the State of Victoria for the period ending 31 December 1985:

Adams, Ronald J.
Anderson, Keith J.
Archard, Hillary
Bachelor, Rexine D.
Ballentine, Christine
Barber, Norman
Barnard, Joan B.
Blair, Robert K.
Boadle, Anne
Boulton, Helen M.
Butcher, Cheryl
Cavalier, Vincent L.
Chandler, Maren
Cook, Robert
Cooper, Frank
Dobie, James A.
Dunn, Kaye
Ebery, Ella
Ellison, Philip R.
Erck, Lois
Fisher, James
Gates, Eleanor
Geary, Brian T.
Haythorpe, Josephine
Hildebrandt, Patricia
Hynes, Elaine J.
Johnson, Patricia L.
Kelly, John
Knowles, Barry
McEwan, Barbara
McNight, Margaret
Maher, Jennifer
Major, Russell
Mitchell, Valerie
Moore, Jill
Morris, Lorraine
Nuttall, Brian
O'Connell, Glenys
O'Keefe, Dorothy
Pratt, Philomena
Roberts, Joan
Segat, Edna
Shelton, Veronica
Singleton, Barry
Smith, Alan
Smith, Barry
Stevenson, Valerie

Taverna, Joseph
Taverna, Theresa
Taylor, Marjorie
Teague, Barry
Walker, Brian
Wallis, Jeffrey
Wilkins, Kathleen
Wolfe, Barbara
Wright, Nola
Young, David

Dated 24 February 1993

LYNNE JORDAN
Acting Regional Director
Loddon-Mallee Region

Children and Young Persons Act 1989
**APPOINTMENT OF HONORARY
PROBATION OFFICER**

I, Mark Diamond (Regional Director) Health and Community Services, Gippsland Region, under section 34 (4) of the *Children and Young Persons Act 1989* appoint the undermentioned person as Honorary Probation Officer for the Children's Court in the State of Victoria until 31 December 1995:

Michael Wilson
Dated 5 March 1993

MARK DIAMOND
Regional Director

ORDERS IN COUNCIL

Post-Secondary Education Act 1978
AWARDING OF MASTERS DEGREES

The Governor in Council, under section 38 of the *Post-Secondary Education Act 1978*, confers on the governing body of the institution listed below the power to award the degree specified to the persons named.

As required by section 38 of the *Post-Secondary Education Act 1978*, the Victorian Post-Secondary Education Commission has certified that the course of study for the degree specified is comparable in standard to that which leads to the award of a degree at a university.

<i>Institution</i>	<i>Degree</i>	<i>Person to whom the Degree is to be Awarded</i>
Ballarat University College	Master of Applied Science (by Publication)	Geoffrey Ernest Sykes
Ballarat University College	Master of Education	Rosemary Jean Selkirk

Dated 3 February 1993

Responsible Minister:

HADDON STOREY

Minister for Tertiary Education and Training

DAMIEN O'SHEA

Clerk of the Executive Council

Crown Land (Reserves) Act 1978
REVOCATION OF TEMPORARY
RESERVATIONS

The Governor in Council under section 10 of the *Crown Land (Reserves) Act 1978* revokes the following temporary reservations:

APOLLO BAY—The temporary reservation by Order in Council of 12 July 1966 of 1012 square metres of land in Section 4, Township of Apollo Bay, Parish of Krambruk as a site for Public purposes (Police purposes)—(Rs 8619).

BAIRNSDALE—The temporary reservation by Order in Council of 10 August 1965 of 734 square metres of land in Section 29, Township of Bairnsdale, Parish of Bairnsdale as a site for Public purposes (Police Department)—(Rs 8536).

COLAC—The temporary reservation by Order in Council of 12 January 1982 of 872 square metres of land being Crown Allotment 43A, Township of Colac as a site for Police purposes—(Rs 11859).

KILMORE—The temporary reservation by Order in Council of 9 February 1872 of 4047 square metres of land in the Township of Kilmore as a site for a Common School, revoked as to part by Orders in Council of 26 September 1972 and 18 August 1992, so far as the balance remaining containing 557 square metres—(Rs 4136).

MARYBOROUGH—The temporary reservation by Order in Council of 19 January 1960 of 1265 square metres, more or less, of land in Section 33c, Township of Maryborough as a site for a Kindergarten, revoked as to part by Order in Council of 16 May 1989, so far as the balance remaining containing 1173 square metres, more or less—(Rs 7876).

MARYBOROUGH—The temporary reservation by Order in Council of 14 March 1990 of 45.6 square metres of land being Crown Allotment 13b, Section 33c, Township of Maryborough, Parish of Maryborough as a site for a Kindergarten—(Rs 7876).

MARYBOROUGH—The temporary reservation by Order in Council of 2 October 1951 of 2.023 hectares of land in the Township of Maryborough, Parish of Maryborough as a site for Public recreation and drainage purposes, revoked as to part by Order in Council of 29 September 1959, so far only as the portion containing 700 square metres, more or less, as indicated by hatching on plan published in the *Victoria Government Gazette* on 4 February 1993—page 235—(M 66[14]) (Rs 6079).

TERANG—The temporary reservation by Order in Council of 18 July 1924 of 1621 square metres of land in the Township of Terang as a site for Police purposes, revoked as to part by Order in Council of 19 November 1968 so far as

Victoria Government Gazette

the balance remaining containing 863 square metres—(Rs 2971).

WURRIN—The temporary reservation by Order in Council of 7 April 1981 of 440 square metres of land being Crown Allotment 1, Parish of Wurrin as a site for Police purposes—(17/849).

Dated 5 March 1993

Responsible Minister:

M. A. BIRRELL

Minister for Conservation and Environment

DAMIEN O'SHEA

Clerk of the Executive Council

Crown Land (Reserves) Act 1978
CROWN LANDS TEMPORARILY
RESERVED

The Governor in Council under sections 4 and 7 of the *Crown Land (Reserves) Act 1978* temporarily reserves for the purposes mentioned and also nominates as areas for which consent of the person or manager administering or managing the lands is required before work may be done on those lands in accordance with the *Mineral Resources Development Act 1990*, the following Crown lands:

MUNICIPAL DISTRICT OF THE CITY OF
ARARAT

ARARAT—Public purposes, 5 hectares, more or less, being Crown Allotment 10E, Section M, Township of Ararat, Parish of Ararat as indicated by hatching on plan hereunder—(A 148[9]) (Rs 21039).

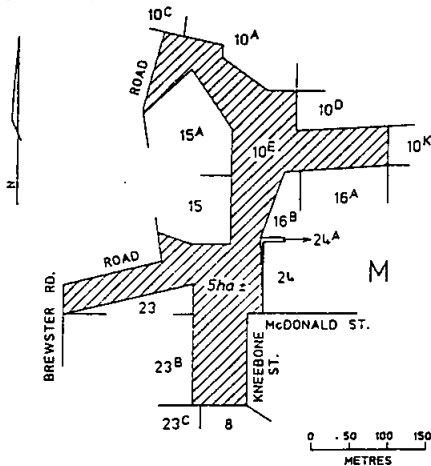

G 10 11 March 1993 513

MUNICIPAL DISTRICT OF THE SHIRE OF
AVOCA

AVOCA—Public purposes, 7.5 hectares, more or less, being Crown Allotment E3, Parish of Avoca as indicated by hatching on plan hereunder—(O.P. A85[4]) (Rs 21030).

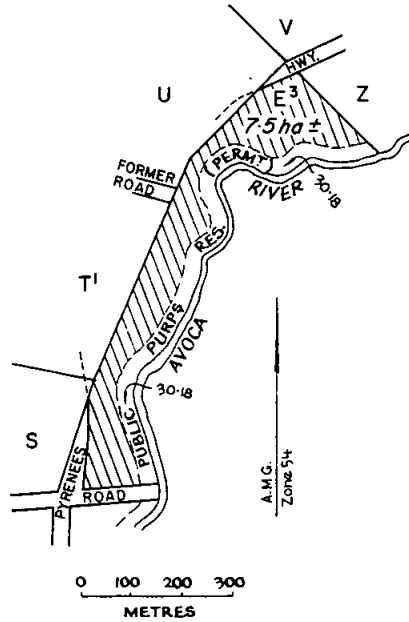

MUNICIPAL DISTRICT OF THE SHIRE OF
MILDURA

MALLOREN—Preservation of species of native plants, 75.15 hectares being Crown Allotment 48A, Parish of Malloren as indicated by hatching on plan hereunder—(M 597[3], M 597) (Rs 14369).

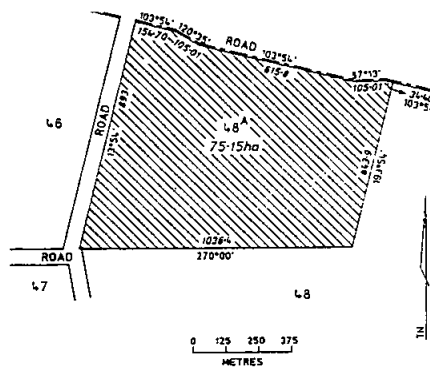

514 G 10 11 March 1993

MUNICIPAL DISTRICT OF THE CITY OF MARYBOROUGH

MARYBOROUGH—Kindergarten, 1716 square metres being Crown Allotment 13G, Section 33c, Township of Maryborough, Parish of Maryborough as shown on Certified Plan No. 111680 lodged in the Central Plan Office—(Rs 7876).

MUNICIPAL DISTRICT OF THE CITY OF MARYBOROUGH

MARYBOROUGH—Public recreation and drainage, 130 square metres, more or less, being Crown Allotment 13H, Section 33c, Township of Maryborough, Parish of Maryborough as indicated by hatching on plan hereunder—(Rs 6079).

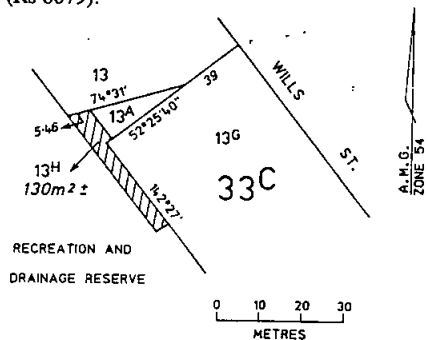

MUNICIPAL DISTRICT OF THE SHIRE OF BIRCHIP

WARMUR—Conservation of an area of natural interest, 7.198 hectares being Crown Allotment 8A, Parish of Warmur as indicated by hatching on plan hereunder—(W 321[6]) (Rs 14368).

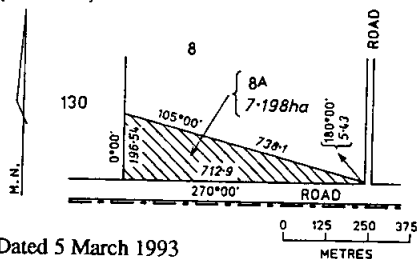

Dated 5 March 1993
Responsible Minister:

M. A. BIRRELL

Minister for Conservation and Environment
DAMIEN O'SHEA
Clerk of the Executive Council

Victoria Government Gazette
Crown Land (Reserves) Act 1978
CROWN LANDS TEMPORARILY
RESERVED

The Governor in Council under sections 4 and 7 of the *Crown Land (Reserves) Act 1978* temporarily reserves for the purposes mentioned and also nominates as areas for which consent of the person or manager administering or managing the lands is required before work may be done on those lands in accordance with the *Mineral Resources Development Act 1990*, the following Crown lands:

MUNICIPAL DISTRICT OF THE CITY OF ARARAT

ARARAT—Public park, 5046 square metres being Crown Allotment 1, Section 89, Township of Ararat, Parish of Ararat as shown on Certified Plan No. 103371 lodged in the Central Plan Office—(Rs 21042).

MUNICIPAL DISTRICT OF THE CITY OF ARARAT

ARARAT—Hospital, 902 square metres being Crown Allotment 5c, Section 30, Township of Ararat, Parish of Ararat as indicated by hatching on plan hereunder—(A 148[9]) (Rs 3868).

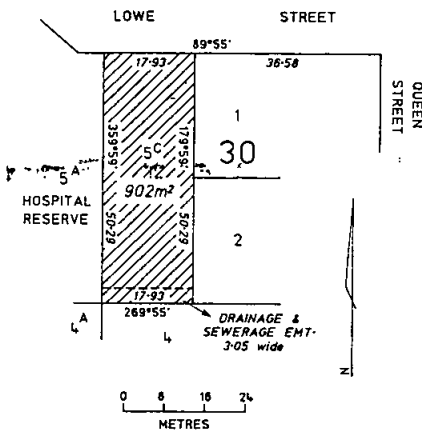

MUNICIPAL DISTRICT OF THE SHIRE OF BUNGAREE

BALLARAT NORTH—Public park, 4640 square metres being Crown Allotment 4A, Section 24, Township of Ballarat North, Parish of Ballarat as indicated by hatching on plan hereunder—(B 128[93]) (Rs 10318).

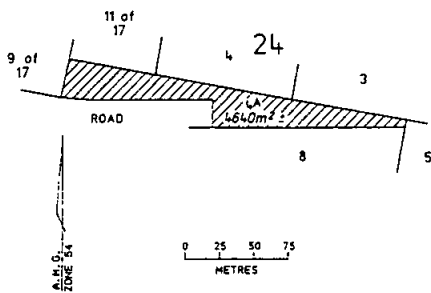

MUNICIPAL DISTRICT OF THE SHIRE OF WARRACKNABEAL

BANGERANG—Conservation of an area of natural interest, 10.52 hectares being Crown Allotment 76E, Parish of Bangerang as indicated by hatching on plan hereunder—(B 658(5)) (Rs 35138).

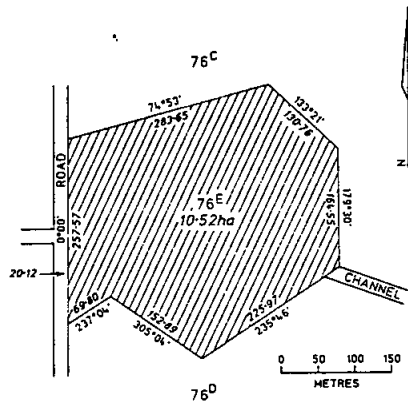

MUNICIPAL DISTRICT OF THE SHIRE OF STAWELL

LEXINGTON and MOKEPILLY—Conservation of an area of natural beauty, 385 hectares, more or less, being Crown Allotments B29, B30 and B31, Parish of Lexington and Crown Allotments 69 and 70A, Parish of Mokepilly as indicated by hatching on plan hereunder—(3140, L39(6)) (Rs 35120).

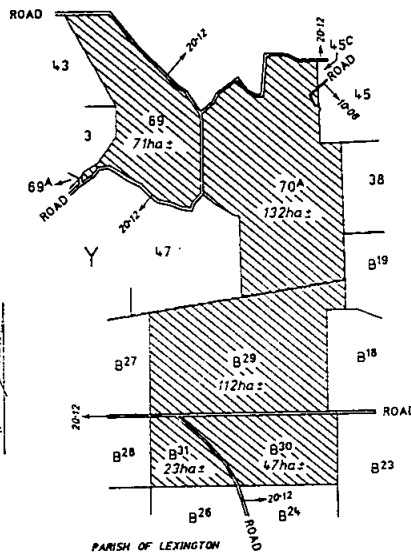

Total area of hatched portions 385ha :

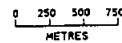

MUNICIPAL DISTRICT OF THE CITY OF PORTLAND

PORTLAND—Public park and recreation, 19.5 hectares, more or less, being Crown Allotment 3D, Section 44, Township of Portland, Parish of Portland as indicated by hatching on plan hereunder—(P 69(7)) (Rs 6150).

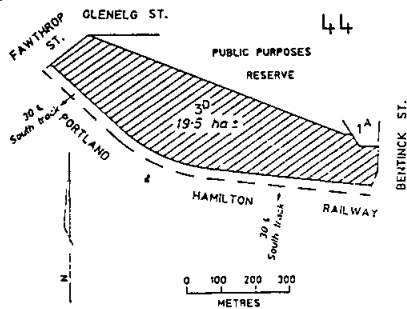

Dated 5 March 1993

Responsible Minister:

M. A. BIRRELL

Minister for Conservation and Environment

DAMIEN O'SHEA

Clerk of the Executive Council

516 G 10 11 March 1993

Crown Land (Reserves) Act 1978
NOTICE OF INTENTION

The Governor in Council under section 10 of the *Crown Land (Reserves) Act 1978* gives notice of intention to revoke the following temporary reservations:

GEELONG—The temporary reservation by Order in Council of 2 December 1986 of 563 square metres of land being Crown Allotment 4A, Section 72, City of Geelong, Parish of Corio as a site for Public Buildings (Property and Services)—(Rs 13375).

JIKA JIKA—The temporary reservation by Order in Council of 9 January 1973 of 9.49 hectares of land in Section 99A, Parish of Jika Jika as a site for Public Purposes (Children's Welfare Purposes), revoked as to part by Order in Council of 8 September 1992 so far only as the portion containing 332 square metres as indicated by hatching on plan hereunder—(M 314[M]) (Rs 259).

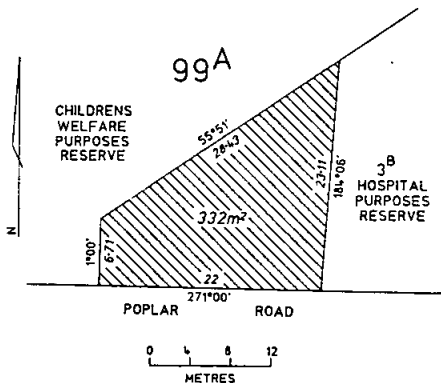

MURRAMURRANGBONG—The temporary reservation by Order in Council of 25 June 1877 of 6854 square metres of land in Section 1, Parish of Murrumbidgee is a site for public purposes (State School), revoked as to part by Order in Council of 15 May 1962 so far as the balance remaining containing 1037 square metres, more or less—(Rs 7901).

NETHERBY—The temporary reservation by Order in Council of 5 October 1926 of 1.214 hectares of land in the Township of Netherby, Parish of Warraquil as a site for a State School in addition to and adjoining the site temporarily reserved therefor by Order in Council of 10 December 1888 so far only as the portion containing 1391 square metres shown as Crown Allotment 11, Section 3, Township of Netherby

Victoria Government Gazette

on Certified Plan No. 111806 lodged in the Central Plan Office—(Rs 3372).

SANDHURST—The temporary reservation by Order in Council of 8 July 1980 of 797 square metres of land being Crown Allotment 164a, Parish of Sandhurst as a site for Community Welfare Services purposes—(Rs 10958).

Dated 5 March 1993

Responsible Minister:

M. A. BIRRELL

Minister for Conservation and Environment

DAMIEN O'SHEA

Clerk of the Executive Council

Crown Land (Reserves) Act 1978
CROWN LANDS TEMPORARILY
RESERVED

The Governor in Council under sections 4 and 7 of the *Crown Land (Reserves) Act 1978* temporarily reserves for the purposes mentioned and also nominates as areas for which consent of the person or manager administering or managing the lands is required before work may be done on those lands in accordance with the *Mineral Resources Development Act 1990*, the following Crown lands:

MUNICIPAL DISTRICT OF THE CITY OF
ARARAT

ARARAT—Public Park, 8497 square metres being Crown Allotment 10k, Section M, Township of Ararat, Parish of Ararat as shown on Certified Plan No. 110892 lodged in the Central Plan Office—(Rs 21043).

MUNICIPAL DISTRICT OF THE SHIRE OF
STAWELL

BOROKA—Public purposes, 1155 square metres being Crown Allotment 7g, Parish of Boroka as shown on Certified Plan No. 104510 lodged in the Central Plan Office—(Rs 477).

Dated 5 March 1993

Responsible Minister:

M. A. BIRRELL

Minister for Conservation and Environment

DAMIEN O'SHEA

Clerk of the Executive Council

Crown Land (Reserves) Act 1978
CROWN LAND PERMANENTLY
RESERVED

The Governor in Council under sections 4 and 7 of the *Crown Land (Reserves) Act 1978* permanently reserves for the purpose mentioned and also nominates as an area for which consent of the person or manager administering or managing the land is required before work may be done on that land in accordance with the *Mineral Resources Development Act 1990*, the following Crown land:

MUNICIPAL DISTRICT OF THE SHIRE OF
ALBERTON

TARRA TARRA—Conservation of an area of natural interest, 4.057 hectares being Crown Allotment 30F, Parish of Tarra Tarra as indicated by hatching on plan hereunder—(T 69(3)) (14/Rs 6611).

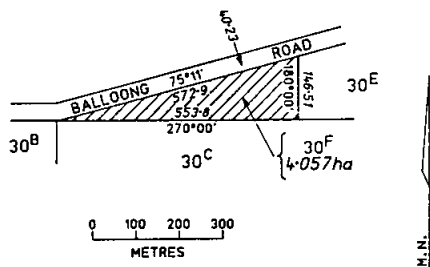

Dated 5 March 1993

Responsible Minister:

M. A. BIRRELL

Minister for Conservation and Environment

DAMIEN O'SHEA

Clerk of the Executive Council

Crown Land (Reserves) Act 1978
NOTICE OF INTENTION

The Governor in Council under section 10 of the *Crown Land (Reserves) Act 1978* gives notice of intention to revoke the following temporary reservations:

BUNINYONG—The temporary reservation by Order in Council of 14 August 1979 of 663 square metres of land being Crown Allotment 23, Section 24, Township of Buninyong, Parish of Buninyong as a site for Water Supply purposes so far only as the portion containing 446 square metres shown as Crown Allotment 24, Section 24, Township of Buninyong on Certified Plan No. 111803 lodged in the Central Plan Office—(Rs 10906).

MALMSBURY—The temporary reservation by Order in Council of 18 April 1961 of 33.59 hectares, more or less, of land in the Township of Malmsbury, Parish of Edgecombe as a site for the purposes of the Social Welfare Department, revoked as to part by Order in Council of 23 January 1968 so far only as the portion containing 6.931 hectares being Crown Allotments 9, 10, 11, 12, 13, 14, 15, 16 and 17, Section 4A, Township of Malmsbury as shown on Certified Plan No. 111795 lodged in the Central Plan Office—(Rs 358).

PANNOOMILLOO—The withholding from sale, leasing and licensing and exception from occupation under any miner's right or business licence by Order in Council of 18 February 1878 of 8.091 hectares of land in the Parish of Pannoomilloo (formerly part of Allotment 88)—(06/P123782).

PIANGIL WEST—The temporary reservation by Order in Council of 27 July 1915 of 8086 square metres of land in the Parish of Piangil West (formerly part of Allotment 64) as a site for a State School—(Rs 1082).

PINES—The temporary reservation by Order in Council of 9 December 1941 of 4047 square metres of land adjoining Crown Allotment 40, Parish of Pines as a site for State School purposes—(Rs 5303).

SOUTH MELBOURNE—The temporary reservation by Order in Council of 19 February 1963 of 2909 square metres of land adjoining Crown Allotment 55A, City of South Melbourne, Parish of Melbourne South as a site for Municipal Purposes (Car Parking)—(Rs 8208).

TUROAR—The temporary reservation by Order in Council of 19 May 1924 of 1.214 hectares of land being Crown Allotment 21A, Parish of Turoar as a site for a State School—(Rs 2935).

Dated 5 March 1993

Responsible Minister:

M. A. BIRRELL

Minister for Conservation and Environment

DAMIEN O'SHEA

Clerk of the Executive Council

Crown Land (Reserves) Act 1978
REVOCATION OF TEMPORARY
RESERVATIONS

The Governor in Council under section 10 of the *Crown Land (Reserves) Act 1978* revokes the following temporary reservations:

518 G 10 11 March 1993

ARARAT—The temporary reservation by Order in Council of 1 August 1864 of 4047 square metres of land in Section 59, Township of Ararat as a site for a Borough Pound, revoked as to part by Order in Council of 15 July 1889, so far as the balance remaining containing 3946 square metres—(Rs 13446).

MALDON—The temporary reservation by Order in Council of 23 November 1868 of the Crown lands comprised within the limits of deviation of the surveyed line of railway from Castlemaine to Maryborough, via Maldon and Newstead, so far only as the portion containing 1785 square metres shown as Crown Allotments 16 and 17, Section 16, Township of Maldon, Parish of Maldon as shown on Certified Plan No. 111249 lodged in the Central Plan Office—(GL 16484).

TINAMBA—The temporary reservation by Order in Council of 15 October 1968 of 912 square metres of land in the Parish of Tinamba as a site for Public purposes (Police purposes)—(Rs 9061).

Dated 5 March 1993

Responsible Minister:

M. A. BIRRELL

Minister for Conservation and Environment

DAMIEN O'SHEA

Clerk of the Executive Council

Crown Land (Reserves) Act 1978

NOTICE OF INTENTION

The Governor in Council under section 10 of the *Crown Land (Reserves) Act 1978* gives notice of intention to revoke the following temporary reservations:

KERANG—The temporary reservation by Order in Council of 3 June 1969 of 34.69 hectares of land in the Township of Kerang as a site for Public park and recreation, revoked as to part by Order in Council of 21 August 1979 so far as the balance remaining containing 29.71 hectares—(Rs 9174).

KERANG—The temporary reservation by Order in Council of 18 September 1979 of 4.978 hectares of land being Crown Allotment 21, Section 46, Township of Kerang Parish of Kerang as a site for State School purposes—(Rs 8640).

LYNDHURST—The temporary reservation by Order in Council of 31 December 1918 of 9181 square metres of land in the Parish of Lyndhurst, in two separate portions, as a site for

Victoria Government Gazette
railway purposes, so far only as the portion containing 900 square metres as indicated by hatching on plan hereunder—(Rs 1878).

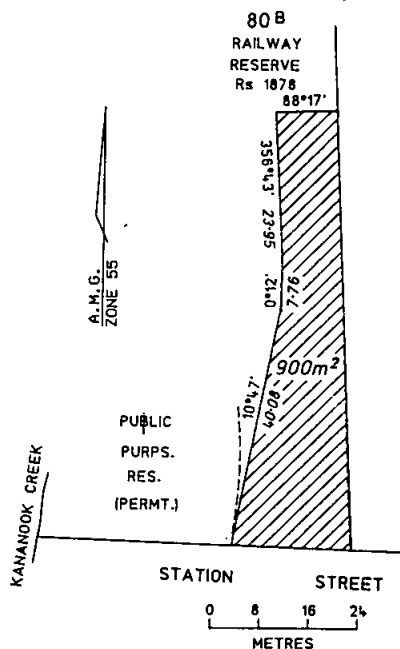

ORBOST—The temporary reservation by Order in Council of 18 October 1977 of 5060 square metres, more or less, of land being Crown Allotment 25B, Township of Orbost, Parish of Orbost as a site for Public Purposes (Hall and Gardens)—(Rs 10472).

Dated 5 March 1993

Responsible Minister:

M. A. BIRRELL

Minister for Conservation and Environment

DAMIEN O'SHEA

Clerk of the Executive Council

Crown Land (Reserves) Act 1978

REVOCATION OF PERMANENT RESERVATION

The Governor in Council under section 11 (2) of the *Crown Land (Reserves) Act 1978* revokes the following permanent reservation:

CASTLEMAINE—The permanent reservation by Order in Council of 5 April 1921 of 2023 square metres of land being Crown Allotments 9 and 10, Section 84, Township of

Victoria Government Gazette

Castlemaine, Parish of Castlemaine as a site for a District High School—(Rs 2279).

Dated 5 March 1993

Responsible Minister:

M. A. BIRRELL

Minister for Conservation and Environment
DAMIEN O'SHEA
 Clerk of the Executive Council

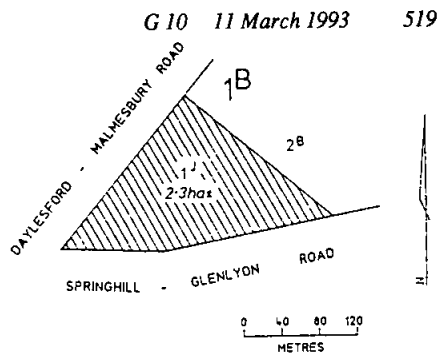

Crown Land (Reserves) Act 1978
 APPOINTMENT OF TRUSTEE
 DIAMOND CREEK LITERARY INSTITUTE
 AND FREE LIBRARY RESERVE

The Governor in Council under section 12 of the *Crown Land (Reserves) Act 1978* appoints Patrick Murphy as a trustee of the land being Crown Allotment 2, Section 14, Township of Diamond Creek (formally Nillumbik), Parish of Nillumbik, County of Evelyn permanently reserved as a site for a Literary Institute and Free Library by Order in Council of 22 April 1890 in the place of Thomas William Harrington (deceased)—(Rs 5833).

Date 5 March 1993

Responsible Minister:

M. A. BIRRELL

Minister for Conservation and Environment
DAMIEN O'SHEA
 Clerk of the Executive Council

Crown Land (Reserves) Act 1978
 CROWN LANDS TEMPORARILY
 RESERVED

The Governor in Council under sections 4 and 7 of the *Crown Land (Reserves) Act 1978* temporarily reserves for the purposes mentioned and also nominates as areas for which consent of the person or manager administering or managing the lands is required before work may be done on those lands in accordance with the *Mineral Resources Development Act 1990*, the following Crown lands:

MUNICIPAL DISTRICT OF THE SHIRE OF
 DAYLESFORD AND GLENLYON

BURKE—Conservation of an area of natural interest, 2.3 hectares, more or less, being Crown Allotment 1j, Section 1b, Parish of Burke as indicated by hatching on plan hereunder—(2293) (Rs 6787).

MUNICIPAL DISTRICT OF THE CITY OF
 FRANKSTON

LYNDHURST—Conservation of an area of natural interest, 20.93 hectares, more or less, being Crown Allotment 86b, Parish of Lyndhurst as indicated by hatching on plan hereunder—(L 101(9)) (Rs 37018).

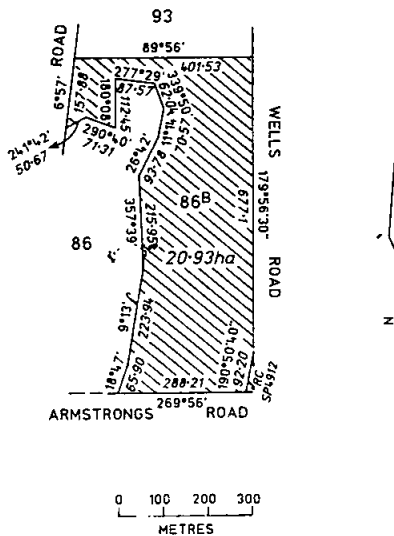

Dated 10 March 1993

Responsible Minister:

M. A. BIRRELL

Minister for Conservation and Environment
DAMIEN O'SHEA
 Clerk of the Executive Council

520 G 10 11 March 1993

Crown Land (Reserves) Act 1978

NOTICE OF INTENTION

The Governor in Council under section 10 of the *Crown Land (Reserves) Act 1978* gives notice of intention to revoke the following temporary reservations:

BAIRNSDALE—The temporary reservation by Order in Council of 7 April 1981 of 759 square metres of land being Crown Allotment 86a, Township of Bairnsdale, Parish of Bairnsdale as a site for Police purposes—(Rs 11454).

CARDIGAN—The temporary reservation by Order in Council of 24 May 1977 of 778 square metres of land being Crown Allotment 4A, Section 11, Parish of Cardigan as a site for Public purposes (Police purposes)—(Rs 10397).

GEELONG—The temporary reservation by Order in Council of 6 February 1951 of 1012 square metres of land in Section 75, City of Geelong, Parish of Corio as a site for Police purposes—(Rs 6532).

JIKA JIKA—The temporary reservation by Order in Council of 9 January 1973 of 9.49 hectares of land in the Parish of Jika Jika as a site for Public purposes (Childrens Welfare purposes) revoked as to part by Order in Council of 8 September 1992, so far only as the portion containing 2.430 hectares shown as Crown Allotment 5b, Section 99A, Parish of Jika Jika on Certified Plan No. 111618—(Rs 259).

MANDURANG—The temporary reservation by Order in Council of 6 March 1865 of 4047 square metres of land in Section 6, Parish of Mandurang as a site for a Common School—(Rs 3716).

MANDURANG—The temporary reservation by Order in Council of 4 February 1947 of 4047 square metres of land in Section 6, Parish of Mandurang as a site for State School purposes in addition to and adjoining the site temporarily reserved for a Common School by Order in Council of 6 March 1865—(Rs 3716).

MINCHA—The temporary reservation by Order in Council of 3 July 1893 of 1.027 hectares of land adjoining Crown Allotment 31, Parish of Mincha as a site for a State School—(L6-4502).

WARRANOOK—The temporary reservation by Order in Council of 24 October 1887 of 8094 square metres of land in the Parish of Warranook (formerly part of Allotment 185) as a site for a State School—(Rs 35085).

Victoria Government Gazette

WOODSTOCK—The temporary reservation by Order in Council of 12 May 1873 of 8094 square metres of land in the Parish of Woodstock (formerly part of Allotment 5, Section 1), as a site for State School Purposes—(Rs 11751).

Dated 10 March 1993

Responsible Minister:

M. A. BIRRELL

Minister for Conservation and Environment

DAMIEN O'SHEA

Clerk of the Executive Council

Land Act 1958

UNUSED ROAD CLOSED

The Governor in Council under section 349 of the *Land Act 1958* and with the consent in writing of the municipality concerned closes the following unused road:

MUNICIPAL DISTRICT OF THE SHIRE OF GRENVILLE

SMYTHESDALE—The road in the Parish of Smythesdale as indicated by hatching on plan hereunder—(S 297[8]) (91-1121).

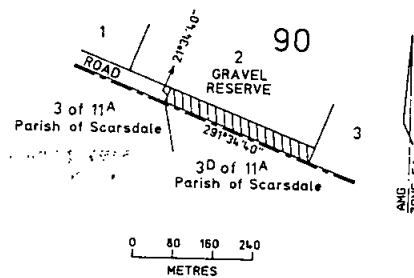

Dated 5 March 1993

Responsible Minister:

M. A. BIRRELL

Minister for Conservation and Environment

DAMIEN O'SHEA

Clerk of the Executive Council

Land Act 1958

UNUSED ROADS CLOSED

The Governor in Council under section 349 of the *Land Act 1958* and with the consents in writing of the municipalities concerned and the adjoining owners closes the following unused roads:

MUNICIPAL DISTRICT OF THE SHIRE OF
AVOCA

AVOCA—The road in the Parish of Avoca as indicated by hatching on plan hereunder—(O.P. A85[4]) (Rs 21030).

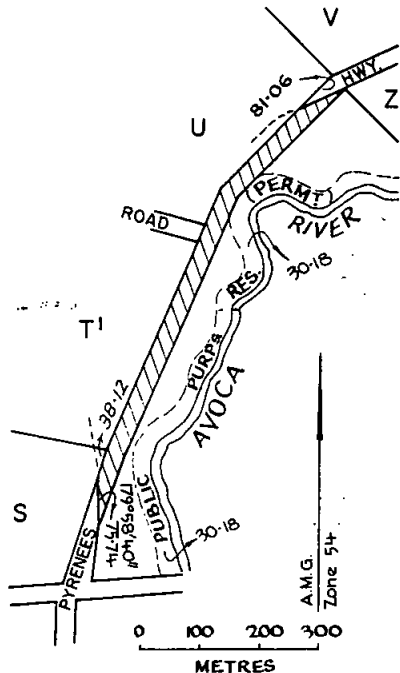

MUNICIPAL DISTRICT OF THE SHIRE OF
BALLAN

BLACKWOOD—The road in the Parish of Blackwood shown as Crown Allotment 39K, Section B on Certified Plan No. 110360 lodged in the Central Plan Office—(L1-3505).

MUNICIPAL DISTRICT OF THE SHIRE OF
METCALF

ELPHINSTONE—The road in the Township of Elphinstone, Parish of Elphinstone shown as Crown Allotment 14A, Section A on Certified Plan No. 100937 lodged in the Central Plan Office—(W 90653).

Dated 5 March 1993

Responsible Minister:

M. A. BIRRELL
Minister for Conservation and Environment
DAMIEN O'SHEA
Clerk of the Executive Council

Land Act 1958
UNUSED ROADS CLOSED

The Governor in Council under section 349 of the *Land Act 1958* and with the consents in writing of the municipalities concerned and the adjoining owners closes the following unused roads:

MUNICIPAL DISTRICT OF THE SHIRE OF
NATHALIA

PICOLA—The road in the Parish of Picola shown as Crown Allotment 1g, Section A, Parish of Picola on Certified Plan No. 111539 lodged in the Central Plan Office—(GL/10868).

MUNICIPAL DISTRICT OF THE SHIRE OF
VIOLET TOWN

VIOLET TOWN—The road in the Township of Violet Town, Parish of Shadforth shown as Crown Allotment 5A, Section F2 on Certified Plan No. 111667 lodged in the Central Plan Office—(L7-1085).

Dated 5 March 1993

Responsible Minister:

M. A. BIRRELL
Minister for Conservation and Environment
DAMIEN O'SHEA
Clerk of the Executive Council

Land Act 1958
UNUSED ROAD CLOSED

The Governor in Council under section 349 of the *Land Act 1958* and with the consent in writing of the municipality concerned and the adjoining owners closes the following unused road:

MUNICIPAL DISTRICT OF THE SHIRE OF
SHERBROOKE

SCORESBY—The road in the Parish of Scoresby shown as Crown Allotment 65A, Section A on Certified Plan No. 111621 lodged in the Central Plan Office—(GL 15693S).

Dated 10 March 1993

Responsible Minister:

M. A. BIRRELL
Minister for Conservation and Environment
DAMIEN O'SHEA
Clerk of the Executive Council

522 G 10 11 March 1993

FIREARMS ACT 1958

The Governor in Council under section 4 (1) (g) of the *Firearms Act* 1958 declares the firearms on the following attachment to be antique:

Firearms to be declared antique

2 mm Kolibri (model 1913)
3 mm Kolibri (model 1913)
4.25 mm Liliput or Erika
5 mm Bergmann No. 2 (models 94 and 96)
6.5 mm Bergmann No. 3 (models 94 and 96)
8 mm Bergmann-Schmeisser (model 94)
8 mm Bergmann-Schmeisser (model 96)
7 mm French Thick Rim
9 mm French Thick Rim
12 mm French Thick Rim
5 mm Clement
8 mm Lebel (models 1886 and 1892)
9 mm Japanese model 1893
10.8 mm Montenegrin No. 4
11.3 mm Montenegrin or Gasser
11.4 mm Montenegrin No. 5
11.2 mm Gasser model 1882
11.35 mm Schouboe
-41 x 1/2 inch Derringer
-410 English Revolver (model 1894)
-430 Tranter Revolver (long and short case)
-442 Tranter Revolver (long and short case)
-577 Boxer Revolver (model 1868)
-577 Revolver (model 1870)

Rifles

-25-36 Marlin Model 1895
-256 Newton
-25 Remington
-275 Holland and Holland Flanged Magnum
-276 Enfield Model 1913
-280 Flanged Nitro-Express
-280 Rimless Nitro-Express (Ross)
-295 Rook
-375/303 Express
-32 Winchester self-loader (model 1906)
-333 Rimless Nitro-Express
-333 Rimmed Nitro-Express
-35-30 Maynard (model 1905)
-400/350 Nitro-Express
-401 Winchester self-loader (model 1910)
-402 Enfield-Martini (model 1887/88)
-44 Henry Centre-fire
-450 Henry or Martini-Henry (model 1869, long case)

Victoria Government Gazette

-461 Gibbs (Nos 1 and 2)
-577/500 x 3 1/4 inches Express
-500 Westley Richards No. 2 Express
20 guage/-577
-58 U.S. Musket (Berdan)
-58 U.S. Carbine
4 guage Rifle
8 guage Rifle
10 guage Rifle
12 guage Rifle
16 guage Rifle
8 x 50 mm Austrian Mannlicher (models 1888 and 1895)
8 x 53 mm Japanese Murata (model 1889)
8.2 x 45 mm Krinka (model 1897)
10.15 x 61 mm Jarmann
11 x 50 mm Belgian Braendlin-Albini
11 x 60 mm Murata (models 13 and 18)
11.43 x 59 Turkish Peabody
12.7 x 44 mm Swedish-Norwegian-Danish Remington
13 x 92 mm German Anti-Tank rifle

Shotguns

4 guage
8 guage
14 guage
18 guage
32 guage
-360 calibre

Dated 5 March 1993

Responsible Minister:

PATRICK McNAMARA

Deputy Premier

Minister for Police and Emergency Services

DAMIEN O'SHEA

Clerk of the Executive Council

CONTROL OF WEAPONS ACT 1990

The Governor in Council under section 5 (1) of the *Control of Weapons Act* 1990, grants the following exemptions:

Mr Hermann Kerner of 4/26 Hopetoun Street, Moonee Ponds to enable him to keep a blow gun and darts for ornamental display.

Mr Johnny Yiannaros of 93 Purinuan Road, Reservoir to enable him to possess a butterfly knife and a "kris" (a thick bladed broad sword with jagged edges on both sides) for use in martial arts demonstrations and training.

Mr Rodney Ng of 6 Panorama Drive, Forest Hill to enable him to possess daggers and cane swords for the purpose of practice, display and exhibition of martial arts.

Dated 5 March 1993

Responsible Minister:

PATRICK McNAMARA

Deputy Premier

Minister for Police and Emergency Services

DAMIEN O'SHEA

Clerk of the Executive Council

Reserve No.	State Wildlife Reserve	Parish
190	Sheepwash, Charam	Charam
192	Little Donkey Woman Swamp	Charam
193	Silver Lake	Charam
194	O'Keefe Swamp	Charam
195	Pot Brook	Yallakar
196	Lake Mullancoree	Wombelano
198	Okely Swamp	Gymbowen
200	The Reserve	Kalingur
201	Hateleys Lake	Arapiles
204	Chain of Lakes	Arapiles, Toosan
205	Heard Lake	Lowan, Toosan
206	Boundary Swamp	Lowan
209	Bow Lake	Jilpanger
210	Lake Coyrahilla (Copper colour)	Toolongrook
211	Greens Swamp	Toolongrook
212	North, Centre and other Lakes	Toolongrook
213	White Lake, Douglas	Toolongrook
214	Bitter Swamp	Toolongrook
215	McGlashin Swamp	Toolongrook
216	Teatree Swamp	Kout Narin
220	Kingcourt Swamp	Wonwondah
221	Donald (Dollin) Swamp	Dollin
222	Red Gum Swamp, Jallumba	Carchap
223	White Swamp	Connangorach
224	Connangorach Swamp	Connangorach
225	Wash Tomorrow Swamp	Toolondo
228	Lake Muirhead	Parrie Yalloak
229	Mount William Swamp	Watgania
231	Swamp	Bunnugal
232	The Green Swamp	Bunnugal
264	Green Swamp	Leeor
265	Ding-A-Ding	Ding-A-Ding
268	Yarrackigarra	Minimay
270	Freshwater Swamp	Yarrook
272	Swamp	Dahwedarre
273	Peechember Swamp	Mirampiram
274	Red Plains Swamp	Mirampiram
275	Bill's Gully	Lawloit
276	Merwyn Swamp	Lawloit
277	Lake Lawloit	Lawloit (Township)
278	Yanac Swamp	Yanac-a-yanac
280	Harding's Swamp	Tarranginnie
286	Swamp	Ni Ni
287	Coker Dam	Gerang Gerung
291	Gum Swamp	Vectis East
292	Verandah Swamp	Wail
293	Cloughs Waterholes	Katyil
294	Crow Swamp (Phillips Dam)	Tarranyurk

Wildlife Act 1975
 CLASSIFICATION OF STATE WILDLIFE RESERVES AS STATE GAME RESERVES AND REVOCATION OF SUCH CLASSIFICATION FROM 11 MARCH 1994

The Governor in Council under section 15 (2) of the *Wildlife Act 1975* further classifies the State Wildlife Reserves in the Schedule below as State Game Reserves from 12 March 1993 and under section 15 (2) revokes this further classification on and from 11 March 1994.

SCHEDULE

Reserve No.	State Wildlife Reserve	Parish
148	Creswick Swamp	Marnoo
161	Lake Jaie Jaie	Boikerbert
162	Leah Swamp	Boikerbert
164	Lignum Swamp	Murrundarra
165	Yallamatta Swamp	Bringalbart
166	Victory Swamp	Boorooopki
167	Bens Swamp	Boorooopki
168	Charlegrark Swamp	Boorooopki
170	Winter Lake	Jallakin
172	School Swamp	Jallakin
173	McCosslen Swamp	Jallakin
174	Lake Yampitcha	Edenhope
175	Lumeah Swamp	Edenhope
176	Sheepwash, Edenhope	Edenhope
177	Hurley's Bank	Edenhope
178	Brickie Swamp	Edenhope
179	Lake Kemi Kemi	Edenhope
180	Kurrayah Swamp	Durong
181	Champion Swamp	Awonga
182	Broughtons Swamp	Awonga
183	West Hut Swamp	Awonga
184	Alakilu Swamp	Awonga
185	Lake Cogumbul	Awonga
186	Woolshed Swamp	Charam
187	Wally Allen's Swamp	Goroke
188	Lake Koynock	Karnak
189	Lake Karnak	Karnak

<i>Reserve State Wildlife</i> No.	<i>Reserve</i>	<i>Parish</i>
295	Seven Mile Dam	Katyl
297	Coorong Swamp	Rupanyup
100	Lake Jollicum	Nerrin Nerrin
102	Blue Lake	Kornong
103	Pink Lake	Kornong
104	Salt Lake	Kornong
124	Lake Gilliar	Mepunga
125	Lake Aringa	Belfast
126	Goose Lagoon	Belfast
227	Victoria Lagoon	Woolpooer
42	Tooloy-Lake Mundi	Byjuke, Tooloy
48	Lake Condah	Condah, Dunmore
92	Pieracle Swamp	Killara
93	Lake Kennedy	Linlithgow
95	Tabor Swamp	Yatchaw East
97	Lake Eyang	Eilyar
98	Lake Oundell	Nerrin Nerrin
99	Nerrin Nerrin	Nerrin Nerrin
120	Aire River	Aire
123	Cobrico Swamp	Elingamite
137	Greens Creek Swamp	Malakoff
140	Middle Swamp	Eglinton
155	L. Turangm'ke, Yuangmania, Gunjal	Parupa
157	Lake Wongan	Wongan
230	Lake Buninjon	Kiora
58	Merin Merin Swamp	Eglinton
6	Lake Goldsmith	Yangerahwill and Township of Stockyard Hill
143	Thunder Swamp	Tandarra
241	Cemetery Forest	Kerang
242	Two Mile Swamp	Tragowel
243	Westblades Swamp	Murabit West
244	McDonald Swamp	Gannawarra
245	Red Gum Swamp	Gannawarra
246	Rowland Reserve	Macoma
247	Flannery Reserve	Macoma
248	Swamp	Turrumberry
250	Baillieu Lagoon	North Turrumberry
299	Lake Jil Jil	North Banyenong
301	Cherrip Swamp	Corack East
75	Stevenson Swamp	Dartagook
252	Reedy Swamp	Shepparton
253	Black Swamp (Nine Mile Creek)	Drumanure
254	Gum Swamp	Karramomus
255	McBurney Swamp	Tamleugh
256	Lehmann Swamp	Tamleugh
257	Shire Dam Swamp	Tamleugh
258	Jubilee Swamp	Upotipotpon, Wills

<i>Reserve State Wildlife</i> No.	<i>Reserve</i>	<i>Parish</i>
259	Moodie Swamp	Waggarandall
260	Tungamah Swamp	Tharanbegga
261	Rowan Swamp	Karrabumet, Bungeet
262	Big Reedy Lagoon	Burramine
263	Black Swamp (Black Dog Creek)	Boorhaman
49	Clarke Lagoon	Tintaldr
50	Jeremal	Tintaldr
51	Tintaldr	Tintaldr
1	Jack Smith Lake	Woodside, Darriman
236	Fresh-water Swamp	Balloong
237	Lake Denison	Giffard
13	Clydebank Morass	Nuntin
2	Lake Coleman	Dulungalong
27	Dowd Morass	Glencoe
55	Heart Morass	Sale, Nuntin
11	McLeod Morass	Bairnsdale
32	Blond Bay	Goon Nure
9	Jones Bay	Broadlands
14	Ewing Morass	Tildesly West, Tildesly East, Newmerall and Waygara

Dated 10 March 1993

Responsible Minister:

M. A. BIRRELL

Minister for Conservation and Environment

DAMIEN O'SHEA

Clerk of the Executive Council

Local Government Act 1989

OFFICE OF LOCAL GOVERNMENT

Direction Specifying the Date of an
Extraordinary Election for the City of
Springvale

The Governor in Council under section 43 of
the *Local Government Act 1989* directs that the
election to fill an extraordinary vacancy created
on 15 February 1993 in the North Ward of the
City of Springvale, be held on 7 August 1993.

Dated 10 March 1993

Responsible Minister:

ROGER MURRAY HALLAM

Minister for Local Government

DAMIEN O'SHEA

Clerk of the Executive Council

Local Government Act 1958

CITY OF HEIDELBERG

Confirmation of Separate Rate

The Governor in Council acting under section 287 of the *Local Government Act 1958* confirms a separate rate made by the Council of the City of Heidelberg on 21 September 1992 to provide for the revitalisation of the East Ivanhoe Shopping Centre.

Dated 10 March 1993

Responsible Minister:

ROGER MURRAY HALLAM
Minister for Local Government

DAMIEN O'SHEA
Clerk of the Executive Council

Local Government Act 1989

OFFICE OF LOCAL GOVERNMENT

Direction Specifying the Date of an
Extraordinary Election for the City of Caulfield

The Governor in Council under section 43 of the *Local Government Act 1989* directs that the election to fill an extraordinary vacancy created on 18 February 1993 in the South Ward of the City of Caulfield, be held on 7 August 1993.

Dated 10 March 1993

Responsible Minister:

ROGER MURRAY HALLAM
Minister for Local Government

DAMIEN O'SHEA
Clerk of the Executive Council

Victorian Prison Industries Commission Act
1983

APPOINTMENT OF PART-TIME MEMBER

The Governor in Council under section 8 of the *Victorian Prison Industries Commission Act 1983* appoints Anthony Robert Delves as a part-time member of the Victorian Prison Industries Commission from 5 March 1993 to 4 March 1994 both dates inclusive.

Dated 5 March 1993

Responsible Minister:

PATRICK McNAMARA
Minister for Corrections

DAMIEN O'SHEA
Clerk of the Executive Council

LATE NOTICE

UNITED CORPORATION (AUSTRALIA)
PTY. LTD.

A. C. N. 051 059 128

The South Australian Brewing Company Limited A. C. N. 007 869 310 has brought a Summons in Action No. 382 of 1993 in the Supreme Court of South Australia seeking the winding up of United Corporation (Australia) Pty Ltd.

The Summons is listed for hearing on Tuesday, 6 April 1993 at not before 2.15 p.m.

Any creditor or contributory of United Corporation (Australia) Pty Ltd wishing to be heard on the Summons must file and serve a notice in accordance with Rule 32 of the Corporations Rules 1991 at least three (3) business days before the day on which the summons is listed for hearing and must attend the Supreme Court House, Victoria Square at the time set for the hearing of the Summons.

A copy of the Summons and the Affidavit in Support can be obtained on payment of the proper costs from Mellor Olsson, 5th Floor, 80 King William Street, Adelaide, S.A. 5000, solicitors for the creditor.



528 G 10 11 March 1993

Victoria Government Gazette





•

•

•

•



530 G 10 11 March 1993

Victoria Government Gazette



1

1

1

1





5



.

.

.

.



CONTENTS

	Page
Appointments	511
Contracts Accepted—Amendments	504
Estates of Deceased Persons	480
Government Notices	490
Late Notice	526
Melbourne Water	502
Orders in Council—	
Acts—Crown Land (Reserves); Local Government; Wildlife; Land; Post-Secondary Education; Firearms; Control of Weapons; Victorian Prison Industries Commission	512
Private Advertisements	470
Proclamations	488
Rural Water	479
Tenders	504

A Victorian Government Publication

Published by
THE LAW PRINTER
a business unit of

Printing and Publishing Services Victoria (PPSV)
Melbourne Victoria Australia

© State of Victoria 1993

This publication is copyright. No parts may be reproduced
by any process except in accordance with the provisions
of the Copyright Act.

Address all inquiries to the Government Printer
for the State of Victoria

PO Box 292 South Melbourne 3205 Victoria Australia
ISSN 0819—5471

L. V. North, Government Printer Melbourne

Mail and Bulk Order Sales

The Law Printer
PO Box 292 South Melbourne 3205
28 Queensbridge Street, South Melbourne
Telephone inquiries (03) 242 4600
Fax (03) 242 4699

Counter Sales

Information Victoria Bookshop
318 Lt. Bourke Street Melbourne 3000
Telephone inquiries (03) 651 4100

Recommended Retail Price \$1.60