



Victoria Government Gazette

No. G 25 Thursday 29 June 1995

GENERAL

GENERAL GAZETTE

Copy to: Government Gazette Officer
THE LAW PRINTER
28 Queensbridge Street, South Melbourne
(PO Box 292 South Melbourne 3205)
DX19, Melbourne
Telephone inquiries (03) 2424605
Fax No. (03) 2424630 only.

Advertising Rates and Payment

Private Notices

Payment must be received in advance with advertisement details.

30 cents per word—Full page \$180.00

An additional cost must be included in prepayment if a copy of the gazette is required. Cheques should be made payable to The Law Printer.

Government and Outer Budget Sector Notices

Not required to pre-pay

Advertisements must be faxed, and a cover sheet should be used, marked to the attention of the Gazette Coordinator.

Single column x cm/part cm \$2.65

Double column x cm/part cm \$5.30

Full page \$111.00

Copy Deadline: 11.00 a.m. Monday—(Private)

9.30 a.m. Tuesday—(Government and Outer Budget Sector)

Copy Prices—Page \$1.50
—Certified \$3.50
—Gazette \$3.20

(All prices include Postage)

Advertisers should note:

■ Late copy received at THE LAW PRINTER after deadlines will be placed in the following issue of VGG, irrespective of any date/s mentioned in the copy (unless otherwise advised).

■ Proofs will be supplied only when requested or at the direction of the Gazette Officer.

■ No additions or amendments to material for publication will be accepted by telephone.

■ Departments are requested not to lodge Executive Council papers for gazette unless a copy is provided with the Governor or Clerks signature on the relevant document.

■ Government and Outer Budget Sector Agencies Please note:

To ensure that material received can be reproduced, and that errors are minimised, the following guidelines are to be observed when submitting material by fax.

Fax Number (03) 242 4630

Use this fax number only for material for the Government Gazette.

Fax resolution

Material sent by fax should be transmitted using Fine resolution (200 dots per inch by 200 dpi). Normal resolution is unacceptable.

Font Size

Use 12 point (10 pitch) or larger.

Font Style

Clear plain font styles, such as Helvetica, should be used.

Graphics

Line drawings should be transmitted as large as possible to ensure clarity. Drawings up to A4 size sent by fax using Fine resolution provide a good quality for reproduction.

Avoid

Italics, underlining, and full justification.

Ensure document is square when sending

Documents that are sent skewed are difficult to read and process.

If material does not meet above requirements your advertisement may not be published.

PERIODICAL AND SPECIAL GAZETTES

Copy to: Juanita Frantz, Legislative Officer
THE LAW PRINTER
28 Queensbridge Street, South Melbourne
(PO Box 292 South Melbourne 3205)
DX19, Melbourne
Telephone inquiries (03) 2424610
Fax No. (03) 2424630 only.

Advertising Rates and Payment

Private Notices

Periodical Gazette

Full page \$180.00

Special Gazette

Full page \$360.00

Payment must be received in advance with notice details.

Government and Outer Budget Sector

Periodical Gazette

Full page \$115.50

Special Gazette

Full page \$233.00

SUBSCRIPTIONS AND RETAIL SALES

Copies of the Victorian Government Gazette can be purchased from THE LAW PRINTER by subscription.

VGG is available by three subscription services:

General and Special—\$165.00 each year

General, Special and Periodical—\$220.00 each year

Periodical—\$110.00 each year

Subscriptions are payable in advance and accepted for a period of one year. All subscriptions are on a firm basis and refunds for cancellations will not be given.

All payments should be made payable to THE LAW PRINTER. Subscription inquiries (03) 2424606, Fax (03) 242 4680.

Copies of the Victorian Government Gazette can be purchased from Information Victoria, 318 Little Bourke Street, Melbourne, over the counter or by mail. Telephone enquiries (03) 651 4100.

INDEX TO PRIVATE ADVERTISERS

A	S
Aitken Walker & Strachan 1544	Sale by the Sheriff 1547
	Slater & Gordon 1545
B	V
Basile & Co. 1544	Victorian Water Supply 1543
Beck Sheahan Quinn & Kirkham 1545	
Blake Dawson Waldron 1545	W
C	Wendie Ivy Clarke 1543
Cheryl Tebble 1543	
D	
David Milne 1543	
E	
East Gippsland Region Water Authority 1543	
Edward R. Oates 1545	
F	
F. R. E. Dawson & Son 1546	
Felice Minichelli 1543	
G	
Ges Zuccala 1543	
Graeme David Hawkins 1543	
Gray, Friend & Long 1544	
H	
Hall & Wilcox 1545	
Harris Lieberman Boyd 1544	
I	
Ingpen & Bent 1543	
J	
Jennifer Anne McKean 1543	
L	
Littleton Hackford 1544	
M	
M. Norris 1546	
Macpherson & Kelley 1546	
N	
National Mutual Trustees Limited 1545	
P	
Patrick J. Cannon Coburn & Associates Pty. 1545, 1546	
Perpetual Trustees Victoria Limited 1546	
R	
Rennick & Gaynor 1545	
Rennick Gaynor Kiddle Briggs 1546	
Rigby Cooke 1546	

PRIVATE ADVERTISEMENTS

EAST GIPPSLAND REGION WATER
AUTHORITY

By-Law

In accordance with section 161 of the Water Act 1989, the East Gippsland Region Water Authority adopted the following By-Law at its meeting held on 20 June 1995.

By-Law No. 001—Water Supply and sewerage Plumbing Administrative By-Law.

This by-law is about water supply and sewerage plumbing administration including the procedures to be followed and the setting of fees and charges.

Copies of the above By-Law is available for inspection during office hours at the Authority's Office, 133 Macleod Street, Bairnsdale.

D. J. ROBERTS
General Manager

The partnership between Wendie Ivy Clarke and Cheryl Tebble trading as 'Video Haircraft Training' was dissolved on 25 June 1995. Wendie Ivy Clarke will continue the business.

MESSRS WRIGHT SMITHS, solicitors, 2 Seventh Avenue, Rosebud

Notice is hereby given that the partnership previously conducted by Ges Zuccala, David Milne and Felice Minichelli at 212 Coventry Street, South Melbourne under the name of Q Microsystems was dissolved on 31 March 1995. All debts due and owing by the said firm will be received and paid by Felice Minichelli who will continue to carry on business at the same place.

Dated 15 June 1995

GES ZUCCALA
DAVID MILNE

GOULBURN VALLEY WATER

By-law No. 503

Water Supply and Sewerage Plumbing
Administrative By-law

Notice is hereby given that the Authority, in accordance with section 160 of the Water Act 1989, has, by resolution dated 21 June 1995, made By-Law No. 503.

The By-law provides for control and authorisation of works of water supply and sewerage throughout the Authority's urban water and sewerage districts and includes a schedule of charges unit prescribing fees for services provided under the By-law.

The By-law incorporates the Victorian Water Supply and Sewerage Plumbing Regulations 1994 and the National Plumbing and Drainage Code AS 3500. The By-law will come into effect on 1 July 1995.

The By-law may be inspected at the Authority's Operations Centre, Old Dookie Road, Shepparton and a copy may be purchased for a fee of \$10.00.

L. J. GLEESON
Chief Executive

NOTICE OF DISSOLUTION OF
PARTNERSHIP

G. D. Hawkins and J. A. McKean

Take notice that the partnership between Graeme David Hawkins and Jennifer Anne McKean as pharmacists trading at 23 Detroit Crescent, Corio was determined on 27 June 1995.

WILLEMINA DELFGAAUW, late of 59 Kansas Avenue, Bell Post Hill in the State of Victoria, widow, deceased

Creditors, next of kin and others having claims in respect of the estate of the abovenamed deceased, who died on 21 March 1995, are required by the trustee Wayne Eason to send particulars of their claims to the trustee care of the undermentioned solicitors by 7 September 1995, after which date the trustee may convey or distribute the assets having regard only to the claims of which he then has notice.

INGPEN & BENT, solicitors, 95 Yarra Street, Geelong

KATHLEEN BEATRICE NELLIE
BROOKER, late of 85 Sutton Street,
Warragul, widow, deceased

Creditors, next of kin and others having claims in respect of the estate of the deceased, who died on 22 March 1995, are required by the

trustees Valerie Kay Hunt, Malcolm William Brooker and Robert Allan Brooker to send particulars of their claims to them care of the undersigned solicitors by 30 August 1995, after which date the trustees may convey or distribute the assets having regard only to the claims of which they then have notice.

GRAY, FRIEND & LONG, solicitors,
Warragul

CLIFFORD JAMES MANLEY, late of
Landsborough Road, Warragul, Victoria,
farmer/grazier, deceased

Creditors, next of kin and others having claims in respect to the estate of the deceased, who died on 27 February 1995, are required by the trustee Frederick Stanley Manley to send particulars of their claims to him care of the undersigned solicitors by 6 September 1995, after which date the trustee may convey or distribute the assets having regard only to the claims of which he then has notice.

GRAY, FRIEND & LONG, solicitors,
Warragul

ERNEST KEITH SINCLAIR, late of 17
Yarralumla, 138 Toorak Road, West South
Yarra, gentleman, deceased

Creditors, next of kin and others having claims in respect of the estate of the deceased, who died on 27 March 1995, are required by the personal representatives Gladys Rose Sinclair, usually known as Jill Sinclair of 17 Yarralumla, 138 Toorak Road, West South Yarra and Stephen Bolton of 12 "Bracklyn", 371 Toorak Road, South Yarra to send particulars to them care of the undermentioned solicitors by 6 September 1995, after which date the personal representatives may convey or distribute the assets having regard only to the claims of which they then have notice.

AITKEN WALKER & STRACHAN,
solicitors, 114 William Street, Melbourne

Creditors, next of kin and others having claims in respect of the estate of Mary Agnes Cantwell, also known as Mary Agnes Jones, late of Main Road, Tyers, Victoria, widow, deceased, who died on 23 April 1995, are to send their claims to the executors Danny Gordon Albert Cantwell of Gormandale and Robert James Cantwell of 1 Willow Court, Traralgon, Victoria, care of the below mentioned solicitors

by 8 September 1995, after which date they will distribute the assets of the deceased having regard only to the claims of which they then have notice.

LITTLETON HACKFORD, solicitors, "Law
Chambers", 115 Hotham Street, Traralgon

FRANK NELL, late of 20 Akuna Avenue,
Tallangatta in the State of Victoria, electrical
mechanic, deceased, who died on 6 April
1995

Creditors, next of kin and all other persons having claims against the estate of the deceased, are required by the executors of the will Judith Anne Witcombe and Peter Francis Nell, to send particulars to them care of the undersigned on or before 29 August 1995, after which date they will distribute the assets having regard only to the claims of which they then have notice.

HARRIS LIEBERMAN BOYD, solicitors,
7 Thomas Mitchell Drive, Wodonga

STANLEY JAMES GURNETT, 99 Shadforth
Street, Kerang in the State of Victoria, retired
farmer, deceased

Creditors, next of kin and all other persons having claims against the estate of the said deceased are required by Stanley James Gurnett (junior) of Inkerman Station, Charleville, Queensland, farmer, Barry Francis Gurnett of Lake Charm, Victoria, farmer and Gregory John Gurnett of 14 North Gateway, Langwarrin, Victoria, disc jockey the executors of the estate of the said deceased to send particulars of such claims to them in care of the undermentioned solicitors on or before 23 August 1995, after which date they will distribute the assets having regard only of the claims to which they then have notice.

BASILE & CO., barristers and solicitors, 46
Wellington Street, Kerang

WILLIAM EVAN KNOWLES, late of 50 East
Esplanade, St. Albans in the State of
Victoria, landlord, deceased

Creditors, next of kin and others having claims in respect of the estate of the deceased, who died on 1 July 1993, are required by Barry Joseph Lawrence Farrugia and Patrick John Cannon, both of 205 Hampshire Road, Sunshine in the said State, solicitors and Darryl Bruce Black of 6 Neilson Street, Penola in the State of South Australia, labourer, the executors to whom probate of the will of the said deceased

was granted by the Supreme Court of Victoria to send particulars care of the undersigned by 7 September 1995, after which date the said executors may convey or distribute the assets having regard only to the claims of which they then have notice.

PATRICK J. CANNON COBURN & ASSOCIATES PTY., solicitors, 205 Hampshire Road, Sunshine

Creditors, next of kin and others having claims in respect of the estate of Lesley Jean Andrea, late of 11 Casey Street, Bendigo, Victoria, home duties, deceased, who died on 23 March 1995, are required by the trustee to send particulars of their claims to the trustee care of the undermentioned solicitors by 8 September 1995, after which date the trustee may convey or distribute the assets having regard only to the claims of which the trustee then has notice.

BECK SHEAHAN QUINN & KIRKHAM, 110 Pall Mall, Bendigo

Creditors, next of kin and others having claims in respect of the estate of Ada Dorothea Margaret Stainsby, late of 25/400 Waverley Road, East Malvern in the State of Victoria, who died on 26 February 1995, are required to send particulars of such claims to the executor Permanent Trustee Company Limited of 294-296 Collins Street, Melbourne, Victoria by 30 August 1995, after which date the said company may convey or distribute the assets having regard only to the claims of which it then has notice.

SLATER & GORDON, solicitors, 562 Little Bourke Street, Melbourne

THURLOW CHESLEIGH BARAGWANATH, late of Unit 31, 112 Elizabeth Street, Richmond in the State of Victoria, retired, deceased

Creditors, next of kin and others having claims in respect of the estate of the deceased, who died on 3 February 1993, are required by the trustee, Chesleigh Antony Baragwanath of 1A Lara Street, Malvern in the said State to send particulars to him by 15 September 1995, after which date the trustee may convey or distribute the assets, having regard only to the claims of which the trustee then has notice.

HALL & WILCOX, solicitors, Level 19, Bourke Place, 600 Bourke Street, Melbourne

Creditors, next of kin and others having claims in respect of the estate of Hazel Myrtle Arnold, late of 16 Grosvenor Street, St Kilda in the State of Victoria, widow, deceased, who died on 28 April 1995, are required to send particulars of such claims to the executor National Mutual Trustees Limited at its registered office at 65 Southbank Boulevard, South Melbourne by 30 August 1995, after which date the executor will distribute the estate having regard only to the claims of which it then has notice.

Creditors, next of kin and others having claims in respect of the estate of Madeleine Cunningham, late of St Annes Nursing Home, 33 Wattle Road, Hawthorn, Victoria, widow, deceased, who died on 29 January 1995, are to send particulars of their claims to Robin Seymour Dennis and Stephen Graham Marks, two of the executors appointed by the said will care of the undersigned by 29 August 1995, after which date they will commence to distribute the assets having regard only to the claims of which they then have notice.

RENNICK & GAYNOR, solicitors, 431 Riversdale Road, Hawthorn East

DORIS WILLISON RUSSELL, deceased

Creditors, next of kin and others having claims in respect of the estate of Doris Willison Russell, late of Surrey Hills Private Nursing Home, 16 Florence Road, Surrey Hills, widow, deceased, who died on 6 June 1995, are to send particulars of their claims to the administrator John Denton, care of the undermentioned solicitor by 15 September 1995, after which date the administrator will distribute the assets having regard only to the claims of which the administrator then has notice.

EDWARD R. OATES, solicitor, 4 Burwood Highway, Burwood

MOLLY ETHEL DELVES, late of Brighton Gardens Accommodation, 29-31 Union Street, Brighton East, widow, deceased

Creditors, next of kin and others having claims against the estate of the said deceased, who died on 8 January 1995, are to send particulars of their claims to The Equity Trustees Executors and Agency Company Limited of 472 Bourke Street, Melbourne by 14 September 1995, after which date it will distribute the assets having regard only to the claims of which it then has notice.

BLAKE DAWSON WALDRON, solicitors, 101 Collins Street, Melbourne

AUDREY PHYLLIS DENEHY, late of "Hurlingham Nursing Home", 68 Union Street, East Brighton, widow

Creditors, next of kin and others having claims in respect of the estate of the deceased, who died on 15 April 1995, are required by Perpetual Trustees Victoria Limited A.C.N. 004 027 258 of 50 Queen Street, Melbourne to send particulars of their claims to the said company by 31 August 1995, after which date it will convey or distribute the assets, having regard only to the claims of which the company then has notice.

ADELAIDE WARD of 9 Wayside Drive, Willow Lodge, 418-440 Frankston-Dandenong Road, Dandenong, widow, deceased

Creditors, next of kin and others having claims in respect of the estate of the deceased, who died on 17 March 1995, are required by Alan Lindsay White of 30 Diosma Drive, Glen Waverley, manager and Colin Henry Madden of 353 Cranbourne Road, Narre Warren, solicitor the executors of the will of the said deceased to send particulars to them in the care of the undermentioned solicitors by 29 August 1995, after which date the said executors may convey or distribute the assets having regard only to the claims of which they then have notice.

MACPHERSON & KELLEY, solicitors, 229 Thomas Street, Dandenong

NORMAN FRANK WHITE, late of 31 High Street Road, Ashwood, Victoria, builder's supplier, deceased

Creditors, next of kin and others having claims in respect to the estate of the deceased who died on 1 October 1994 are required by Perpetual Trustees Victoria Limited A.C.N. 004 027 258 of 50 Queen Street, Melbourne and Alice May White of 31 High Street Road, Ashwood, home duties the applicants for a grant of probate to send particulars of their claims to the said applicants in the care of the said Company by 31 August 1995, after which date they will convey or distribute the assets having regard only to the claims of which they then have notice.

RENNICK GAYNOR KIDDLE BRIGGS, 10th Floor, 530 Little Collins Street, Melbourne

REINA WILLIAMS, late of 18 Ians Grove, Lower Templestowe, librarian, deceased

Creditors, next of kin and others having claims against the estate of the deceased, who died on 22 April 1995, must send particulars of

their claims to the executor Marianne Norris at the address given below by 30 August 1995, after which date the executor shall convey or distribute the assets having regard only to the claims of which she then has notice.

M. NORRIS, 3 Finch Street, Burwood

JOSEPHINE FRISCH, late of Colton Close Nursing Home, 1-19 York Street, Glenroy, widow, deceased

Creditors, next of kin and others having claims in respect of the estate of the deceased, who died on 27 April 1995, are required by Nadia Josephine Frisch of 70 Vida Street, Essendon, social worker, the executor to whom probate of the will of the said deceased was granted by the Supreme Court of Victoria to send particulars care of the undersigned by 31 August 1995, after which date the said executor may convey or distribute the assets having regard only to the claims of which she then has notice.

PATRICK J. CANNON COBURN & ASSOCIATES PTY A.C.N. 067 593 533, solicitors, 205 Hampshire Road, Sunshine

RUBY VIOLET GAIR, late of 34 New Street, Armadale, deceased

Creditors, next of kin and others having claims in respect of the estate of the deceased, who died on 12 March 1995, are required by the executors and trustees Mark Edward Gair of 2 Lorikeet Street, Nunawading, Victoria, student, John Lewis Gair of 65 Columbia Drive, Mulgrave, Victoria, sales engineer, to send particulars to them care of the undermentioned solicitors by 31 August 1995, after which date the executors and trustees may convey or distribute the assets having regard only to the claims of which they have notice.

RIGBY COOKE, solicitors, 242-246 Glenferrie Road, Malvern

JESSIE CHALLINOR, late of Unit 2, 16 Bondi Road, Bonbeach, retired welfare officer, deceased

Creditors, next of kin and others having claims in respect of the estate of the deceased, who died on 13 April 1995, are required by the executrix Dulcie May Chiles of 5A Lennox Street, Hawthorn, to send particulars to her care of her solicitors at the address set out below by 31 August 1995, after which date the executrix may convey or distribute the assets having regard only to the claims of which she then has notice.

F. R. E. DAWSON & SON, solicitors, 83 William Street, Melbourne

The County Court of the State of Victoria
SALE BY THE SHERIFF

On 3 August 1995 at 2.30 p.m. at the Sheriff's Office, 8-20 King Street, Oakleigh (unless process be stayed or satisfied).

All the estate and interest (if any) of Thomas James Langdon of 13 Peregrine Place, Carrum Downs proprietor of an estate in fee simple in the land described on Certificate of Title Volume 9726 Folio 455 upon which is erected a residential dwelling known as 13 Peregrine Place, Carrum Downs.

Registered Mortgage Nos S273733M and S611088L and the Covenant in Instrument M969716C affect the said estate and interest

Terms—Cash only

R. MARTIN
Sheriff's Officer

The County Court of the State of Victoria
SALE BY THE SHERIFF

On 3 August 1995 at 2.30 p.m. at the Sheriff's Office, 8-20 King Street, Oakleigh (unless process be stayed or satisfied).

All the estate and interest (if any) of Andrew Spina and David Spina of Flat 1/153 Roslyn Road, Highton as shown on Certificate of Title as Andrew John Spina and David Anthony Spina registered as tenants in common in equal shares of an estate in fee simple in lot 1 on plan of subdivision 302054T and being the land described on Certificate of Title Volume 10070 Folio 912 upon which is erected a residential unit known as Flat 1, 153 Roslyn Road, Highton.

Registered Mortgage Nos S133030Y and S771416W affect the said estate and interest.

Terms—Cash only

R. MARTIN
Sheriff's Officer

Unclaimed Moneys Act 1962

Register of Unclaimed Moneys held by the—

Name of Owner on Books and Last Known Address	Total Amount Due to Owner	Description of Unclaimed Money	Date when Amount first became Payable
---	------------------------------------	--------------------------------------	--

\$

SANDHURST TRUSTEES LIMITED

Bayly, K S, 363 Deakin Ave, Mildura	203.30	Film Trust	202.89
Box, A E, 10 Owens Ave, Glen Waverley	508.24	"	"
Brown, W R, 17/5-17 Queen St, Newtown	203.30	"	"
Campbell Harvester & Co, 142 Merrigal St, Griffith	101.66	"	"
Clarke, D C, 5/14 The Avenue, Windsor	508.24	"	"
Chatfield, H B, PO Box 58, Burwood	254.12	"	"
Disher, T, 32 Leila Rd, Ormond	254.12	"	"
Garrod, P T, 39 Jacaranda Pl, Wickham	101.66	"	"
Getgood, P R, 2 Hutchinson St, Rivervale	254.12	"	"
Haugen, L, 69 Wellington St, Windsor	609.89	"	"
Heumiller, D and L, PO Box 88, Broadmeadows	101.66	"	"
Hillas, B W, PO Box 971, Wodonga	101.66	"	"
Hobson, N W, 18 Dexter St, Cook	101.66	"	"
Jarman, I C, PO Box 136, Sans Souci	101.66	"	"
Kordick, C J (estate of), 5A Fleet St, North Parramatta	254.12	"	"
Laidlaw, W C, Lot 2 Chinton Rd, Monegetta	508.24	"	"
Masters, A F, 1 Coniston St, Diamond Creek	101.66	"	"
Mitchell, D C, 46 The Parade, Norwood	203.30	"	"
O'Brien, P J, The Wilderness, PO Box 193, Euroa	254.12	"	"
Phelps, E, 3/40 Sunset Blvd, Soldiers Point	152.47	"	"
Phillips, R M, 297 Diamond Creek Rd, Greensborough	304.94	"	"
Wastell, R F, Yarrowa Rd, Moss Vale	406.60	"	"
Wendy's Holdings Pty Ltd, 1 McLaren Rd, Nerang	254.12	"	"

95168
CONTACT: ALAN RILEN, PHONE 9693 9800

Unclaimed Moneys Act 1962

Name of Owner on Books and Last Known Address	Total Amount Due to Unclaimed Owner \$	Description of Unclaimed Money	Date when Amount first became Payable
BUSINESS FINANCIAL SERVICES			
ABELA WILLIAM	560.97	SUPER PAY'T	04/05/89
ABINER CHRISTOPHER ARNOLD	190.59	SUPER PAY'T	11/01/94
ABRAHAM SHARIF	239.18	SUPER PAY'T	06/08/93
ABUBAKER MURLENA	239.81	SUPER PAY'T	26/11/93
ADAMS R	170.07	SUPER PAY'T	09/04/91
ADAMS S R	265.97	SUPER PAY'T	26/03/91
ADAMS SCOTT	136.26	SUPER PAY'T	27/09/93
AETNA INVEST. MANAGEMENT	2,271.68	SUPER PAY'T	20/02/90
AGNEW ROBERT CRAIG	152.24	SUPER PAY'T	05/03/93
AGUILAR SILVIA	160.35	SUPER PAY'T	01/08/91
ALALA PHILLIP	143.07	SUPER PAY'T	29/08/91
ALEC JOHN	153.88	SUPER PAY'T	20/06/91
ALEFOSIO LUI	112.05	SUPER PAY'T	30/05/91
ALEGERINOS BASIL	373.64	SUPER PAY'T	19/07/93
ALLAN STEVEN JOHN	123.39	SUPER PAY'T	28/10/93
ALLEN CATHERINE ANNETTE	395.93	SUPER PAY'T	10/04/90
ALLEN TESS	187.23	SUPER PAY'T	11/01/94
ALLEN THOMAS ALBERT	174.03	SUPER PAY'T	16/11/90
ALLPORT S	370.11	SUPER PAY'T	30/05/91
ALSTERGREN EDWARD W	118.21	SUPER PAY'T	21/02/92
AMIS ROSE	196.52	SUPER PAY'T	30/07/91
AMP APPROVED DEPOSIT FUND	303.32	SUPER PAY'T	17/01/91
AMP SOCIETY	566.11	SUPER PAY'T	04/06/92
AMP SOCIETY	717.75	SUPER PAY'T	09/09/93
AMURU NORA	319.13	SUPER PAY'T	30/06/92
ANDERSON NEVILLE S	101.06	SUPER PAY'T	28/01/89
ANGLA MARIE	143.95	SUPER PAY'T	10/07/92
ANISAH	132.90	SUPER PAY'T	01/03/91
ANSBELL ALAN SBYMOUR	242.93	SUPER PAY'T	11/09/91
ANTHIA JANELLE	131.07	SUPER PAY'T	01/05/92
ANTHONY PETER	127.57	SUPER PAY'T	19/05/93
289 ST GEORGES RD PRESTON 3072			
1/481 MILITARY RD GRANGE SA 5022			
427 RAE ST TNH FITZROY VIC 3068			
211 KINGSWAY CRONULLA NSW 2230			
5 TACRED CRT ALGESTER 4115			
WISE ROAD LOCKINGTON 3563			
225 OSBORNE S WILLIAMSTOWN VIC 3016			
67 ALBERT AVE CHATSWOOD NSW 2067			
728 TIVOLI PLACE 5TH YARRA VIC 3141			
7/18 BISHOP STREET WEST FOOTSCRAY 3011			
27/402 NEPEAN HWY FRANKSTON 3199			
10B YARRAM ROAD BALCATTA WA 6021			
6/17 CAROLINE STREET WESTMEAD NSW 2145			
9/19 MARY ST LIDCOMBE NSW 2141			
UNIT 4/20 MANLY ST WERRIBEE VIC 3030			
19 SHIRLEY ST WENDORAH VIC 3355			
16/17-19 BUSACO RD MARSFIELD NSW 2122			
UNIT 4 16 PETRIE ST FRANKSTON 3199			
2 GEORGE ST PADDINGTON NSW 2021			
414 PARK ST STH MELBOURNE 3025			
23 ANZAC STREET CROYDON 3136			
7-9 LEEDS ST FOOTSCRAY 3011			
3 WOODHIGH CRT LAUNCHING PLACE 3139			
20 PROSPECT STREET BOX HILL VIC 3128			
3 ALEXANDER AVENUE CLAYTON 3168			
98 MACINTOSH ST SHEPARDON 3630			
5/112 BLACKSHAW ROAD NEWPORT 3015			
6/22 WHEELER PDE DEE WHY 2099			
41 PANDEEN ROAD ROCHEDALE QLD 4123			
1/44 BEVAN AVENUE CLAYTON 3168			
8 FORYCE STREET CHELTENHAM VIC 3192			

Unclaimed Moneys Act 1962

Register of Unclaimed Moneys held by the—

Name of Owner on Books and Last Known Address	Total Amount Due to Owner \$	Description of Unclaimed Money	Date when Amount first became Payable
BUSINESS FINANCIAL SERVICES—continued			
APLAR ADNAN	131.30	SUPER PAY'T	29/04/92
ARAMOANA DAWSON DARREN	421.61	SUPER PAY'T	04/06/93
ARENA SHONA	104.48	SUPER PAY'T	12/11/93
ARENDALIE L A	143.03	SUPER PAY'T	14/08/90
ARIANNE ANNE	107.33	SUPER PAY'T	16/05/91
ARMSTRONG ANDREW FRANCIS	186.69	SUPER PAY'T	18/01/94
ARMSTROY HERB	628.78	SUPER PAY'T	04/08/92
ARNALL NANETTE	159.32	SUPER PAY'T	26/11/92
ARNOLD S R	322.57	SUPER PAY'T	24/01/90
ARSLAN KARMEIN	370.33	SUPER PAY'T	30/03/89
ATKINS D C	186.34	SUPER PAY'T	18/03/89
ATKINS SHAUN ALEXANDER	247.19	SUPER PAY'T	04/09/92
ATTARD WILLIAM	5,635.97	SUPER PAY'T	08/07/93
AU CHEE SENG	178.53	SUPER PAY'T	30/07/91
AVERY DONNA MAE	229.80	SUPER PAY'T	08/12/93
BAIGENT SHARLEEN HELEN	141.36	SUPER PAY'T	04/11/93
BAILEY STEPHEN	318.52	SUPER PAY'T	27/09/91
BAIRD KENNETH	246.43	SUPER PAY'T	07/04/93
BAKER DAVID	179.00	SUPER PAY'T	28/08/91
BAKER JASON	1,078.78	SUPER PAY'T	23/04/92
BALNAMES KYM	181.63	SUPER PAY'T	13/05/92
BAMFORD GLEN	381.53	SUPER PAY'T	06/01/94
BAO LIU	127.43	SUPER PAY'T	24/09/91
BARACEROS MR RONALD	131.79	SUPER PAY'T	22/11/93
BARBER DAVID	136.97	SUPER PAY'T	27/09/93
BARBER JANINE M	2,497.38	SUPER PAY'T	22/09/93
BARKER ANDREW GORDON	249.10	SUPER PAY'T	17/08/88
BARLEY PATRICK	557.08	SUPER PAY'T	15/07/93
BARRY ALAN HAROLD	185.87	SUPER PAY'T	06/03/91
BARTL ANNIE CANTWELL	205.50	SUPER PAY'T	06/09/93
5/84 WARRIGAL ROAD MENTONE 3194			
50 DUNBLANE RD NOBLE PARK VIC 3174			
93 MOSLEY ST PORT HEDLAND WA 6721			
3 FRASER ST MIDDLE PARK 3206			
4/71 RIVERSDALE RD HAWTHORN 3122			
RMB 618B ST ARNAUD VIC 3478			
21 YAWLA ST BENTLEIGH 3204			
35 THE PARADE ASCOT VALE 3032			
11/12 MORRISETT ST QUEANBEYAN 2620			
90 MARIBYRNONG ST FOOTSCRAY 3011			
91 SETTLEMENT RD BELMONT 3216			
20 GREY ST EAST GHELONG 3219			
PO BOX 326 BLACK ROCK VIC 3193			
3/16 MAYSTON STREET HAWTHORN EAST 3123			
4 MYHELL CRES QUEENSTOWN SA 5014			
20 ASTRAL AVE CARLISLE WA 6101			
20 JACARANDA AVE, CHELTENHAM 3192			
10 HOCKING STREET FOOTSCRAY VIC 3011			
FLAT 4/16 CHILDERS AVE CRANBOURNE 3977			
17 GLOUCEST ST GROVEDALE 3216			
2 RHEIMS STREET BROADVIEW SA 5083			
1217 WANNEROO RD STUART HILL WA 6060			
1A ARGYLE STREET RESERVOIR 3011			
11A CAREY ST MAGILL SA 5072			
12 WAQRD ST BARDON QLD 4065			
7 MARCELLA PLACE CARRUM DOWNS VIC 3201			
BP AUSTRALIA LTD 120 GREEN RD DANDENONG 3175			
9-11 CAVENAGH ST DARWIN NT 0800			
6 POPLAR STREET NEWCOM 3219			
5 HENBY STREET KENSINGTON VIC 3031			

Unclaimed Moneys Act 1962

Register of Unclaimed Moneys held by the—

Name of Owner on Books and Last Known Address	Total Amount Due to Owner, \$	Description of Unclaimed Money	Date when Amount first became Payable
BUSINESS FINANCIAL SERVICES—continued			
BARTON PEGGY	154.48	SUPER PAY'T	03/06/91
BARY EDITH	951.40	SUPER PAY'T	24/01/92
BASSETT BRETT W	130.07	SUPER PAY'T	24/10/91
BATCHELOR ANNE	120.53	SUPER PAY'T	04/06/93
BATES CHRISTOPHER EDWARDS	127.85	SUPER PAY'T	08/09/93
BATTY MARK	179.50	SUPER PAY'T	19/02/92
BAWDEN JASON	106.38	SUPER PAY'T	05/03/93
BAXTER D	120.66	SUPER PAY'T	23/10/90
BAXTER SUSAN	205.06	SUPER PAY'T	25/01/92
BEASLEY EARLE MALCOLM	229.76	SUPER PAY'T	24/02/93
BEBNARCZYK MIECZYSLAW	246.15	SUPER PAY'T	24/10/91
BBE R	1,477.21	SUPER PAY'T	07/03/91
BEER RONALD NEIL	234.92	SUPER PAY'T	17/11/87
BELL SHANE MICHAEL	186.51	SUPER PAY'T	18/01/94
BENHAM SCOTT J	263.50	SUPER PAY'T	30/05/90
BENNETT CHARLES ALBERT	143.28	SUPER PAY'T	12/01/94
BERECZ TP	122.11	SUPER PAY'T	11/01/91
BERKOVITCH ROSALIND	103.38	SUPER PAY'T	24/05/93
BERRY DALE KENNARD	250.10	SUPER PAY'T	23/12/92
BERRY ROSS ALBERT	193.41	SUPER PAY'T	27/09/93
BERRYMAN SARA LOUISE	161.61	SUPER PAY'T	04/11/93
BEST SCOTT	349.44	SUPER PAY'T	27/04/89
BETTS GRAHAM DOUGLAS	143.20	SUPER PAY'T	27/06/91
BEWLEWY K M	145.26	SUPER PAY'T	16/10/90
BIGWOOD JAMIE	155.89	SUPER PAY'T	04/08/93
BINHDANG VAN	128.12	SUPER PAY'T	22/09/92
BLACKBURN C	142.38	SUPER PAY'T	04/07/91
BLAIR KATHLEEN A	246.90	SUPER PAY'T	20/05/92
BLAKE CHERYL	116.94	SUPER PAY'T	07/01/92
BLAZIC MARIA EVELYN	159.05	SUPER PAY'T	06/01/93
3 MACCALLUM CIRCUIT FLOREY ACT 2615			
182 HOITHAM ROAD NIDDRIE 3042			
4 PAULKNER STREET HAMPTON 3188			
1 PALMER STREET SOUTH MELBOURNE VIC 3205			
5/20 RAGLAN STREET PORT MELBOURNE VIC 3207			
9 ROSEWEL CRT NORLANE WST 3215			
19 ROBERTSON STREET MORWELL VIC 3840			
165 BUNERONG ROAD KINGSTON 2032			
3 EDMOND STREET BALWYN 3103			
5/28 BURWOOD RD HAWTHORN 3122			
5 TREWIN STREET DANDENONG 3175			
LOT 9 5 CHERRYTREE RD HURSTBRIDGE 3099			
RSD YEA VIC 3717			
5 BARKLY ST BALLARAT VIC 3350			
RMB 2259 STRATHMERTON 3641			
5A CASSIA RD PORT HBLAND WA 6721			
25 FALCON DRIVE MELTON 3337			
476 DANDENONG RD CAULFIELD VIC 3161			
SERPENTINE RD MARONG VIC 3515			
27 SHERB ST KENWICK WA 6107			
16/55 ELIZABETH ST STH PERTH WA 6151			
68 SPRING ST PRAIRAN 3181			
36 FENWICK ST CLIFTON HILL 3068			
37 JOHN ST WILLIAMSTOWN 3016			
36 KENT ST EAST VICTORIA PARK WA 6100			
3/113 FLINDERS STREET THORNBURY 3071			
78 FALCONER STREET NORTH FITZROY 3068			
109 KINGSTON RD HEATHERTON 3202			
17 ROBERTSON CRESCENT BORONIA 3155			
30 WESTCOTT STREET EASTLAKES NSW 2018			

Unclaimed Moneys Act, 1962

Register of Unclaimed Moneys held by the—

Name of Owner on Books and Last Known Address	Total Amount Due to Owner	Description of Unclaimed Money	Date when Amount first became Payable
BUSINESS FINANCIAL SERVICES—continued			
BOARDMAN CINDY	137.20	SUPER PAY'T	25/01/93
BOHL TRACEY	130.76	SUPER PAY'T	27/01/93
BOLTON LAURIE	248.47	SUPER PAY'T	18/06/91
BOND CHARLES B	657.28	SUPER PAY'T	09/12/88
BONTE MISS KAREN MARIE	163.21	SUPER PAY'T	15/07/93
BOOTH D	386.20	SUPER PAY'T	08/04/91
BORG JOSEPH	121.34	SUPER PAY'T	07/07/92
BORKE KAREN JUNE	225.93	SUPER PAY'T	14/09/92
BOSWORTH DARANI	145.65	SUPER PAY'T	13/01/94
BOURKE JIM	118.22	SUPER PAY'T	25/07/90
BOURKE P E	193.56	SUPER PAY'T	04/01/91
BOURNE KELLY CHRISTINE	102.59	SUPER PAY'T	14/01/94
BOWDEN R L R	227.54	SUPER PAY'T	05/03/91
BRADY CARMEL MARY	108.29	SUPER PAY'T	15/10/92
BRADY S	279.10	SUPER PAY'T	15/03/91
BRANSON J	166.95	SUPER PAY'T	23/03/92
BRAY JOHN	161.37	SUPER PAY'T	29/06/93
BRAY LISA	223.48	SUPER PAY'T	18/01/94
BRIC MICHAEL ANTHONY	168.99	SUPER PAY'T	25/02/91
BREW PHILLIP	236.27	SUPER PAY'T	27/09/93
BRISTINA ZINETA	108.49	SUPER PAY'T	23/01/92
BRITTAIN TERRY	251.10	SUPER PAY'T	09/02/93
BRITTON ALAN JOHN	141.32	SUPER PAY'T	26/08/91
BROCK T M	167.27	SUPER PAY'T	13/05/91
BROMLEY B A	226.37	SUPER PAY'T	03/12/90
BROOKER MARK LINSAY	212.55	SUPER PAY'T	30/07/90
BROUTON DANIEL	306.53	SUPER PAY'T	28/12/90
BROWN CALLUM	205.65	SUPER PAY'T	28/06/91
BROWN DARREN RONALD	212.27	SUPER PAY'T	19/11/93
BROWN MARY	193.79	SUPER PAY'T	18/01/94
417A AFRASIA ST NEWTOWN 3220			
217 LATHER ST SOUTHPORT QLD 4215			
24 GRANDVIEW GROVE DRUMCONRA 3215			
NOT AVAILABLE			
5/52 EMERY AVE WOODROFFE NT 0830			
30 LYPARDS RD LANGWARRIN 3910			
12 NARRABI STREET QUAKERS HILL NSW 2763			
14/45 BARRABOOL ROAD HIGHTON 3216			
3 GLENGARRY ST WOODVILLE SOUTH SA 5011			
7 FORD STREET FOOTSCRAY 3011			
6 GROWTHER PLACE NTH MELBOURNE 3186			
16 KENT STREET RICHMOND VIC 3121			
33 JASSA ST OAKLEIGH 3166			
58 OCEAN DRIVE PORT FAIRY VIC 3284			
22 VILLAGE DVE SLADES CREEK QLD 4127			
13 FRANCES CRC CRANBOURNE 3977			
9 MEALIN STREET EAST GBELONG VIC 3219			
8 KENNEALY ST SURRAY HILLS VI 3127			
10/17-25 WENTWORTH AVE SYDNEY 2000			
27 NOBL ST HENDRA QLD 4011			
13 SHERWIN WAY MINFO 2566			
LOT 1 MT RIDDELL RD HEALESVILLE 3777			
9 BURDENS CREEK ROAD NT 0830			
22 STANLEY AVE ELTHAM 3095			
21 YUILLE ST FRANKSTON 3199			
7 LAURA PLACE NTH FITZROY 3068			
27 MOIRA AVENUE FERNTREE GULLY 3156			
59 WINDELLA CRES GLEN WAVERLEY 3150			
5 MILLARD ST MT GAMBIER SA 5290			
4/50 BLACK ST BRIGHTON VIC 3156			

Unclaimed Moneys Act 1962

Register of Unclaimed Moneys held by the—		Total Amount Due to Owner	Description of Unclaimed Money	Date when Amount first became Payable
Name of Owner on Books and Last Known Address				
BUSINESS FINANCIAL SERVICES—continued				
BROWN MICHAEL	C/-1101 BURWOOD HIGHWAY FERNTRIEB GULLY 3156	112.84	SUPER PAY'T	04/07/91
BROWN MR COLIN JAMES	LOT 1 PRINCES HWY PAKENHAM VIC 3810	101.28	SUPER PAY'T	18/01/94
BROWN PHILLIP	23 LEWERS ST WATSONIA 3087	258.99	SUPER PAY'T	12/10/90
BRUCK TONY	PO BOX 7043 479 ST KILDA RD MELBOURNE VIC 3004	219.25	SUPER PAY'T	05/08/88
BRUNNEN ANDREW	11/978 MOUNTAIN HWY BORONIA VIC 3155	132.69	SUPER PAY'T	17/03/93
BRYANT JOHN A	2/13 POOLSON ST CARRUM 3197	131.38	SUPER PAY'T	27/07/90
BUCKBY D P	RMB R 288 ROSS CREEK 3351	165.69	SUPER PAY'T	05/12/90
BUCKLAND ALLAN JAMES	20 WHITEHORSE ROAD MOOLAP 3221	120.55	SUPER PAY'T	25/08/92
BUCKLEY GILES	40 ASHBY TCE VIVEASH WA 6056	110.90	SUPER PAY'T	13/01/94
BUI D R	6/1 KOOKARIBB RD CARNEGIE 3163	327.79	SUPER PAY'T	23/05/89
BUIL ASHLEY	C/-RMB 2700 EAGLEHAWK 3556	103.24	SUPER PAY'T	27/08/91
BULL GREGORY	2 JULIEN CRES HOPPERS CROSSING 3030	129.17	SUPER PAY'T	11/07/89
BUNTING ALAN	6/29 THE AVENUE WINDSOR 3181	111.05	SUPER PAY'T	31/01/92
BURGON ANNE MARIE	31 FOREST STREET COLLINGWOOD 3066	233.53	SUPER PAY'T	24/06/91
BURKE C	29 PENTLOWB ROAD WANTIRNA SOUTH 3152	106.32	SUPER PAY'T	25/11/91
BURLEY LAURA ALCIE	FLAT 6/7 LEWISHAM ROAD WINDSOR 3181	257.93	SUPER PAY'T	28/08/91
BURNETT CHRISTOPHER SHANE	3/247 KINGSWAY CARINGBAH NSW 2229	192.19	SUPER PAY'T	23/09/93
BURNETT GHOORB	215 PORT HACKING ROAD MIRANDA NSW 2228	123.95	SUPER PAY'T	01/06/92
BURNS STEVEN	15 BRONWYN STREET BRACKEN RIDGE QLD 4017	136.94	SUPER PAY'T	27/09/93
BURTON RANDALL	13 MAIR STREET KYNETON 3444	102.80	SUPER PAY'T	15/04/92
BYERS CAROL	LOT 76/77 RONALD AVE SELBY 3159	210.28	SUPER PAY'T	09/12/92
BYRNE CHRISTOPHER	63 WILLIAMS RD HORSHAM 3400	163.03	SUPER PAY'T	14/09/88
BYSOWTH TREVOR JOHN	38 MARY ST WATERMAN WA 6020	145.31	SUPER PAY'T	09/11/93
CABLE KENNETH JOSEPH	22/25 BEACONSFIELD PDE W EST ST KILDA VIC 3182	133.90	SUPER PAY'T	25/06/93
CADMAN DENISE KAY	12/66 WELLINGTON RD CLAYTON VIC 3168	118.17	SUPER PAY'T	09/03/93
CAI JING PING	4 CLAROS CLOSE HORNSBY HEIGHTS NSW 2077	156.02	SUPER PAY'T	09/10/90
CALAMOS JOHN	10 CORLETT ST FRANKSTON VIC 3199	322.03	SUPER PAY'T	18/05/89
CAMPBELL C	FLAT 1 29 KOOYONG ROAD ARMADALE 3143	151.48	SUPER PAY'T	22/01/92
CAMPBELL GARRY	72 PINOAK CRES FLEMINGTON 3031	148.59	SUPER PAY'T	08/02/91

Unclaimed Moneys Act 1962

Register of Unclaimed Moneys held by the—

Name of Owner on Books and Last Known Address	Total Amount Due to Owner \$	Description of Unclaimed Money	Date when Amount first became Payable
BUSINESS FINANCIAL SERVICES—continued			
CANNAELA BERNARD JOHN	1,077.10	SUPER PAY'T	28/06/93
CAPLE STEPHEN	197.30	SUPER PAY'T	05/12/91
CARAPPELLOTTI ANN	215.89	SUPER PAY'T	06/01/94
CARDIER MATHEW	141.45	SUPER PAY'T	19/07/93
CAROLAN TONY	136.94	SUPER PAY'T	27/09/93
CARROLL MR LUKE	492.66	SUPER PAY'T	21/05/93
CARROLL PAMELA M	111.44	SUPER PAY'T	10/09/93
CARRUTHERS S	158.30	SUPER PAY'T	25/09/91
CARTER KATRINA	163.76	SUPER PAY'T	01/12/92
CARTLIDGE MARK ANDREW	158.46	SUPER PAY'T	10/06/92
CATHERALL BRIAN	170.38	SUPER PAY'T	18/09/91
CATT VICTORIA ELLEN	117.73	SUPER PAY'T	03/09/91
CAULFIELD MICHAEL	254.39	SUPER PAY'T	05/02/91
CECOT MICHAEL	113.72	SUPER PAY'T	17/05/93
CHAI ANNIE WEI	118.68	SUPER PAY'T	18/01/94
CHAMPNIS ROBERT EDWARDS	147.57	SUPER PAY'T	19/12/90
CHAN GEORGIANA	108.14	SUPER PAY'T	14/01/94
CHAPLIN JOYCE	165.15	SUPER PAY'T	15/04/92
CHAPMAN IAN RALPH	250.84	SUPER PAY'T	14/07/88
CHARLOFF PAUL	186.88	SUPER PAY'T	23/09/92
CHEI LEONA	234.94	SUPER PAY'T	19/08/91
CHEN GENNY	126.96	SUPER PAY'T	29/07/92
CHEN J	229.11	SUPER PAY'T	23/04/91
CHEN LI	287.39	SUPER PAY'T	15/06/89
CHIMIRI VICTORIA ANN	106.09	SUPER PAY'T	24/09/93
CHUM D	451.94	SUPER PAY'T	10/05/91
CLARK ADAM	120.58	SUPER PAY'T	27/09/93
CLARKE BARRY	122.06	SUPER PAY'T	18/01/94
CLARKE MR SIMON CHARLES	117.44	SUPER PAY'T	07/10/93
CLARKE R F	209.08	SUPER PAY'T	27/11/91
74 KEILOR RD NTH ESSENDON VIC 3041			
477 GUARWYN ROAD CARNegie 3163			
C/- KALGOORLIE CVAN PARK BOULDER WA 6432			
237 HUDSON RD WOOLLOOWAN QLD 4030			
27 NOBLE STREET HENDRA QLD			
1303 TOORAK RD BURWOOD VIC 3125			
3 DOUGAL COURT HIGHTON VIC 3216			
13 DENSTON WAY LIDCOMBE 2141			
12 EVELINE STREET MARGATE QLD 4019			
4/52 DUKE STREET SUNSHINE 3020			
27 FREDERICK STREET DANDENONG 3175			
75 BENKEL STREET CHELTENHAM 3192			
3/72 O'CONNELL ST GIBELONG WEST 3218			
59 BLAIR STREET COBURG VIC 3058			
29 HOTHAM CRT GLENORCHY TAS 7010			
7 CLAPHAM STREET SPRINGVALE 3171			
32 ROCKLEA RD BULLIEN VIC 3105			
C/-POST OFFICE MALMSBURY 3446			
3 CARLMURRAY ST BEACONSFIELD QLD 4741			
60 MINNAMURRA RD NORTHBIDGE 2063			
1 PLAZA COURT LILYDALE 3140			
FLAT 14 168 ALBION STREET BRUNSWICK 3057			
8/77 CLUSCEC ST NTH FITZROY 3068			
C/- PO BOX 132 OAKHIGH VIC 3166			
14 SYCAMORE GROVE RIPONLEA VIC 3183			
2/3 WALLACE ST BAYSWATER 3153			
JUBILEE CVAN PARK MT GAMBIER SA 5290			
18 MARTINA ST WANGUN NT 0810			
1 TOWER PL EAST HAWTHORN VIC 3123			
613 HARRY STREET BRUNSWICK WEST 3056			

Unclaimed Moneys Act 1962

Name of Owner on Books and Last Known Address	Total Amount Due to Owner \$	Description of Unclaimed Money	Date when Amount first became Payable
BUSINESS FINANCIAL SERVICES—continued			
CLARKE SHANNON	143.07	SUPER PAY'T	18/01/94
CLARKESON G L	161.37	SUPER PAY'T	29/11/91
CLEWS ROBYN ANNE	140.21	SUPER PAY'T	09/12/92
CLOSE JASON AL	533.80	SUPER PAY'T	22/05/92
CLOSE SALVA	111.63	SUPER PAY'T	21/06/91
CLUFF WARWICK THOMAS	146.07	SUPER PAY'T	22/11/93
COACH TIMOTHY JAMES	130.37	SUPER PAY'T	31/01/92
COATES M	303.73	SUPER PAY'T	26/06/90
COLBRAN D S	198.08	SUPER PAY'T	07/06/90
COLH DARRIN	136.94	SUPER PAY'T	27/09/93
COLHOUN DONNA MARIE	181.53	SUPER PAY'T	18/01/94
COLLINGBOURNE JUDY RUTH	246.43	SUPER PAY'T	21/01/92
COLLINS SHAWN	247.03	SUPER PAY'T	18/01/94
COLONIAL MUTUAL SUPERBRIDGE	1,404.01	SUPER PAY'T	09/08/90
CONNOR MARC ANDREW	138.92	SUPER PAY'T	18/01/94
CONTRERAS E	150.24	SUPER PAY'T	15/02/91
COOPER JAMES	136.94	SUPER PAY'T	27/09/93
CORNELL GRAHAM JAMES	265.58	SUPER PAY'T	21/07/93
COSTA MARIE	227.35	SUPER PAY'T	30/07/90
COULTER PHILIP	300.96	SUPER PAY'T	26/11/91
COWLINGS MR GLEN	227.02	SUPER PAY'T	11/05/89
CRACK L G	241.23	SUPER PAY'T	25/03/91
CRAWSHAW BELINDA ANNE	154.91	SUPER PAY'T	17/11/92
CROWLEY PENELOPE	195.40	SUPER PAY'T	03/03/91
CRUZ TERESITA LOPEZ	169.73	SUPER PAY'T	15/02/93
CSERNIK LAZAR	125.31	SUPER PAY'T	01/10/93
CUTLER MAX LEBDS	187.09	SUPER PAY'T	28/02/91
D & L ELECTRICAL	373.70	SUPER PAY'T	23/02/93
DALE GARRY C	363.71	SUPER PAY'T	23/10/91
DALE(Y) BELINDA JANE	129.53	SUPER PAY'T	06/04/93
5 CAVELL ST SCORESBY VIC 3179			
47 MANORVALE PDE WERRIBEE VIC 3030			
6 PAREPAT COURT WANTIRNA 3152			
39 KURRAWA CRESCENT PATTERSON LAKES 3197			
6 DALLY STREET QUEENSLIFFE NSW 2096			
7 KALGOORLIE HOTEL KALGOORLIE WA 6430			
352 HIGHTT STREET RICHMOND 3121			
17 LANSDOWNE ST SALE 3850			
115 COMANS ST MORWELL VIC 3840			
24 LEITH ST NEWBOROUGH VIC 3825			
146 MOORES POCKET RD TIVOLI QLD 4120			
5 CANTHERBURY PLACE WERRIBEE 3030			
35 SAXSON ST SMITHFIELD SA 5714			
P O BOX 300 WILLAMSTOWN 3016			
19 DAWE STREET AUSTRALIND WA 6230			
4/17 ALFRED ST PRAHRAN 3141			
37 RIVERSIDE DRIVE PALM BEACH QLD 4221			
RMB 3375 HORSHAM VIC 3405			
C/O ELPIN CONT'L KNITWEAR P O BOX 522 BOX HILL			
829 TOORAK ROAD HAWTHORN 3123			
9 BUTCHER ST BENDIGO 3550			
4/205 DANDENONG ROAD WINDSOR 3181			
13 DARNLEY DRIVE MALVERN 3144			
45 EDSAW STREET MALVERN 3144			
13 DARNLEY DRIVE SKYE 3977			
11/170 HALCON ST CROWS NEST NSW 2065			
FLAT 9/5 KING STREET DANDENONG VIC 3175			
26 HILLCREST RD GLENROY 3046			
296 FERNREE GULLY ROAD NOTTING HILL VIC 3168			
2 JANE COURT MERNDA 3754			
5/57 FIRST AVE MT LAWLEY WA 6050			

Unclaimed Moneys Act 1962

Register of Unclaimed Moneys held by the

Name of Owner on Books and Last Known Address	Total Amount Due to Owner	Description of Unclaimed Money	Date when Amount first became Payable
BUSINESS FINANCIAL SERVICES—continued			
DALL KENNETH WILLIAM HARRY	101.49	SUPER PAY'T	18/01/94
DAUD AHMED	121.20	SUPER PAY'T	01/06/92
DAUD LINDY	126.29	SUPER PAY'T	15/04/92
DAVEY K L	177.62	SUPER PAY'T	16/01/92
DAVIDSON MICHELLE	109.68	SUPER PAY'T	18/01/94
DAVIES G L	152.93	SUPER PAY'T	16/02/90
DAVIES ROGER KEITH	119.66	SUPER PAY'T	27/10/93
DAVIS ANGELA	164.47	SUPER PAY'T	10/03/93
DAVIS PETER	166.26	SUPER PAY'T	15/06/93
DAWES BARRY	595.00	SUPER PAY'T	14/05/90
DAWVEROB MART LEWIS	132.74	SUPER PAY'T	02/09/93
DAYAL A	144.24	SUPER PAY'T	29/04/91
DAYTON BEVERLEY ANN	183.84	SUPER PAY'T	17/01/91
DCORKBY SHANE WILLIAM	133.74	SUPER PAY'T	13/03/90
DE AZEVEDO RVI	193.47	SUPER PAY'T	29/07/92
DE BRUYN R	372.21	SUPER PAY'T	20/05/91
DE MELIS ANDREW	131.09	SUPER PAY'T	01/09/93
DE THOMAS ERIC FREDERIC	182.46	SUPER PAY'T	20/09/93
DEAN ANDREW MARK	164.18	SUPER PAY'T	26/01/93
DEAVES MR NOEL	162.80	SUPER PAY'T	24/11/93
DEBONO MARTIN	169.11	SUPER PAY'T	14/05/92
DEEB SIMON	119.11	SUPER PAY'T	27/09/93
DELANEY SHARON	185.24	SUPER PAY'T	14/05/92
DEMOB DAVID	156.59	SUPER PAY'T	20/09/93
DEOMAN FRANCIS JOHN	113.48	SUPER PAY'T	27/08/93
DER BORTOLI ANDREW	281.61	SUPER PAY'T	22/05/89
DEROO BARBARA ANNE	384.66	SUPER PAY'T	14/11/90
DIAS WILLIB	177.51	SUPER PAY'T	22/04/93
DIAZ JOHN	168.09	SUPER PAY'T	29/07/92
DIBBEN B A	543.54	SUPER PAY'T	21/05/90

Unclaimed Moneys Act 1962

Register of Unclaimed Moneys held by the—

Name of Owner on Books and Last Known Address	Total Amount Due to Owner \$	Description of Unclaimed Money	Date when Amount first became Payable
BUSINESS FINANCIAL SERVICES—continued			
DINGLE GREGORY	141.76	SUPER PAY'T	27/09/93
DIVBALDO FRANCES	193.40	SUPER PAY'T	11/01/94
DIXON PETER	977.52	SUPER PAY'T	23/07/93
DODS CAMERON	144.50	SUPER PAY'T	04/06/93
DONNELLY KATHRYN MARIE	183.28	SUPER PAY'T	02/03/92
DOOLEY MICHAEL	136.38	SUPER PAY'T	20/09/91
DOUGLAS P	256.19	SUPER PAY'T	19/04/91
DOYLE ANDREW JOHN	151.29	SUPER PAY'T	21/04/93
DOYLE SHANE FRANCIS	257.05	SUPER PAY'T	20/11/92
DRISCOLL JULIA MAREE	115.70	SUPER PAY'T	06/01/93
DRUMMOND SAMANTHA JANE	187.98	SUPER PAY'T	27/09/91
DUGAN KEIRAN P	1,234.18	SUPER PAY'T	11/05/89
DUNLOP ANDREW	223.66	SUPER PAY'T	01/03/92
DUNPHY JOHN C	141.44	SUPER PAY'T	10/06/92
DUONG N L	209.51	SUPER PAY'T	17/03/91
DURIE ALISON MARY	109.43	SUPER PAY'T	05/03/93
EASTON PETER	257.15	SUPER PAY'T	15/04/92
EDMONDS MARK	936.70	SUPER PAY'T	17/02/93
ELIEH JOHN	160.59	SUPER PAY'T	28/05/92
ELLIOTT GARY	390.17	SUPER PAY'T	20/09/91
ELLIOTT GRAEME ELLIOTT	183.37	SUPER PAY'T	02/03/93
ELLIS PHILIP	109.75	SUPER PAY'T	18/01/94
ELLISON MEREDYTH	105.41	SUPER PAY'T	15/02/90
EMMOTT HEATH	150.59	SUPER PAY'T	20/09/91
EMRE MUSTAFA	152.81	SUPER PAY'T	16/11/93
ENENKEL PETER	103.93	SUPER PAY'T	05/11/93
ERWIN J	291.42	SUPER PAY'T	18/01/91
ESPINOSA D	158.42	SUPER PAY'T	20/06/88
EUDEY D	174.10	SUPER PAY'T	12/04/91
EVANS MERV	204.46	SUPER PAY'T	03/03/92
11/59 CARLISLE ST ST KILDA VIC 3182			
40 BLEINHEIM ST EAST ST KILDA VIC 3182			
35 HILLSIDE CRES MARYLANDS WA 6051			
173 SCOTCHMORE STRBET NORTH FITZROY VIC 3068			
97 NORTHUMBERLAND DRIVE EPPING 3076			
101 CHIRNSIDE AVE WERRIBEE 3030			
3/9 SARGOOD ST ALTONA 3018			
PARKSINCLAIR CHEMICALS PO VOX 21 HAMPTON VIC			
5 YORK STREET FORRESTFIELD WA 6058			
40/1-9 COTTEB DRIVE EPPING NSW 2120			
8 STEWART STREET MURRUMBERRA 3163			
LOT 1 VINEYARD RD SUNBURY 3429			
11 HIGHVIEW DR MOOROOOLBARK 3138			
2 RELIANCE WAY AIRDS NSW 2560			
26 AUSTIN ST FOOTSCRAY 3011			
C/- 74 KENNA AVE HAMILTON VIC 3300			
9 MARGATE CRES GLEN WAVERLEY 3150			
24 ALEC CRESBENT FAWKNER VIC 3060			
153 OPIE ROAD ST ALBANS 3021			
8 COLLINS STREET SURRY HILLS NSW 2031			
5/176 ST GEORGES RD SHEPPARTON VIC 3630			
C/- JAWOYN ASSOC PO BOX 266 KATHERINE NT 0851			
C/O PAC AUST. PO BOX 298 STH YARRA VIC			
37 OTTO CRES FOUNTAIN GATE STH 3805			
19 DRYANDRA CRES KRYSBOROUGH VIC 3173			
184 KBW ST KEWDALE WA 6105			
12/37 NIPPEAN HWY ELSTERNWICK 3785			
230 RICHARDSON ST ESSENDON 3044			
UNIT 4 JAMES ST WHITTFLESEA 3757			
11 MEDA COURT GROVEDALE 3216			

Unclaimed Money Act 1962

Register of Unclaimed Money held by the—

Name of Owner on Books and Last Known Address	Total Amount Due to Owner	Description of Unclaimed Money	Date when Amount first became Payable
BUSINESS FINANCIAL SERVICES—continued			
EVANS ROBERT	117.36	SUPER PAY'T	16/06/93
FABER M	339.16	SUPER PAY'T	03/05/91
FAINGLES KEVIN C	111.62	SUPER PAY'T	22/05/87
FARLEY LYNDA MARBE	388.03	SUPER PAY'T	09/11/92
FAULKNER ROBERT	1,647.57	SUPER PAY'T	18/01/94
FELLOWS CHRISTOPHER	133.52	SUPER PAY'T	22/11/93
FENG JOHN	137.13	SUPER PAY'T	10/05/91
FERGUSON ADAM	135.68	SUPER PAY'T	22/11/93
FERRINAN STEVEN LESLIE	198.36	SUPER PAY'T	29/07/92
FERRARIO JASON	136.16	SUPER PAY'T	27/09/93
FIN A MOO	415.39	SUPER PAY'T	22/05/91
FINDLAY KENNETH IAN	418.23	SUPER PAY'T	24/12/91
FISHER CRAIG JAMES	124.83	SUPER PAY'T	17/05/90
FISHER HJ NO.2 FUND	1,239.09	SUPER PAY'T	19/03/93
FITCH GREGORY NORMAN	349.72	SUPER PAY'T	01/12/93
FITZPATRICK SCOTT ANDREW	196.07	SUPER PAY'T	17/01/91
FLETCHER ROBERT ANDREW	171.14	SUPER PAY'T	02/09/93
FLORENCE ROHAN	189.46	SUPER PAY'T	06/09/91
FLYNN AMANDA RUBY	102.37	SUPER PAY'T	27/08/93
FOARD DIANE	112.85	SUPER PAY'T	19/08/91
FORAN KIM MARIE	121.47	SUPER PAY'T	10/06/93
FORT LYNNIE MARIE	155.52	SUPER PAY'T	18/01/94
FOSTER JOHN CHARLES	123.08	SUPER PAY'T	24/12/93
FOSTER TREVOR	148.03	SUPER PAY'T	22/11/89
FOULDS G (COMPASS FORD P/L)	104.00	SUPER PAY'T	28/09/93
FRANKS C	201.09	SUPER PAY'T	27/09/90
FRASER DOUGLAS	148.19	SUPER PAY'T	28/04/93
FRASER STEPHEN	142.10	SUPER PAY'T	16/11/93
FRATANTARO MARK	130.95	SUPER PAY'T	25/06/93
FREEMAN S A	272.64	SUPER PAY'T	21/06/90

Unclaimed Moneys Act 1962

Register of Unclaimed Moneys held by the—

Name of Owner on Books and Last Known Address	Total Amount Due to Owner	Description of Unclaimed Money	Date when Amount first became Payable
BUSINESS FINANCIAL SERVICES—continued			
FRENCH P	252.10	SUPER PAY'T	25/06/91
FU WALLACE	150.54	SUPER PAY'T	07/08/92
FUENTES MA ANY	621.61	SUPER PAY'T	25/08/92
FUIMAONO T	131.09	SUPER PAY'T	02/11/90
FURNESS BROOK VERITY	157.23	SUPER PAY'T	20/10/93
FURZE LUKE	250.29	SUPER PAY'T	20/02/92
GAGLIANDE ROBERT ANTHONY	108.56	SUPER PAY'T	31/10/91
GALLAGHER BRIAN	233.90	SUPER PAY'T	06/09/91
GANE CARLA	170.51	SUPER PAY'T	14/04/89
GARRARD DARREN PATRICK	667.51	SUPER PAY'T	18/01/94
GATT DENISE	156.35	SUPER PAY'T	21/10/93
GAVIN S F	231.97	SUPER PAY'T	14/04/92
GEMIGNANI MARCO	112.73	SUPER PAY'T	14/02/91
GENG JING HUI	136.26	SUPER PAY'T	27/09/93
GEORGE IAN	286.69	SUPER PAY'T	23/01/89
GERCOVICH DAPHNE	179.97	SUPER PAY'T	27/09/93
GLACOMANTONIO CEM	102.06	SUPER PAY'T	23/04/91
GIBAND JUDITH ANN	193.57	SUPER PAY'T	11/05/90
GIBSON ROBYN	128.42	SUPER PAY'T	14/05/92
GILMER BRADLEY J	197.40	SUPER PAY'T	28/07/93
GITTINGS GENE	721.70	SUPER PAY'T	03/07/90
GIUDICE PETER VINCENT	14.46	SUPER PAY'T	18/01/94
GLENIS GI	244.11	SUPER PAY'T	28/01/93
GLINDEN PTY LTD	233.80	SUPER PAY'T	18/01/94
GLOURY M	335.49	SUPER PAY'T	29/11/93
GOLDEN MICHAEL	190.00	SUPER PAY'T	11/12/90
GOLDING MATT	195.26	SUPER PAY'T	19/02/91
GONG GUXIANG	106.35	SUPER PAY'T	30/08/91
	113.49	SUPER PAY'T	09/08/93
	340.93	SUPER PAY'T	18/10/91

Unclaimed Moneys Act 1962

Register of Unclaimed Moneys held by the—

Name of Owner on Books and Last Known Address	Total Amount Due to Unclaimed Owner \$	Description of Unclaimed Money	Date when Amount first became Payable
BUSINESS FINANCIAL SERVICES—continued			
GOODER GLEN RICHAR	586.51	SUPER PAY'T	28/04/89
GOSSIP HELEN LOUISE	1,444.53	SUPER PAY'T	04/11/92
GOWING TONY	162.46	SUPER PAY'T	18/01/94
GRAHAM DARRIN JAMES	100.11	SUPER PAY'T	29/10/91
GRAHAM PATRICK J	168.34	SUPER PAY'T	23/12/93
GRANGER JENNIFER MAUREEN	212.84	SUPER PAY'T	08/07/92
GRANT MS S	267.84	SUPER PAY'T	04/09/89
GRAY DUNCAN	182.59	SUPER PAY'T	16/10/90
GREGORY A J	103.51	SUPER PAY'T	29/04/91
GRIFFIN RACHAEL KIM	107.82	SUPER PAY'T	23/12/93
GRIFFITHS C	171.83	SUPER PAY'T	04/02/92
GRIMWADE TIMOTHYU	105.91	SUPER PAY'T	15/04/92
GU BEI FEI	159.24	SUPER PAY'T	23/08/93
GUEST MARK VICTOR	203.10	SUPER PAY'T	18/03/93
HAANAPPEL RODNEY	687.00	SUPER PAY'T	26/08/92
HACKETT SONJA	393.89	SUPER PAY'T	18/05/90
HADDAD GITTA	167.58	SUPER PAY'T	23/04/92
HAHN JASON	257.84	SUPER PAY'T	29/04/91
HAIGH AARON	135.81	SUPER PAY'T	27/04/92
HAIMES BRIAN ROBERT	197.30	SUPER PAY'T	23/03/93
HAI PERN	123.25	SUPER PAY'T	27/08/93
HALE ANTHONY	127.90	SUPER PAY'T	31/10/91
HALIM ECKY HIRAWAN	492.24	SUPER PAY'T	29/04/92
HALL D	271.59	SUPER PAY'T	02/06/90
HALL JOHN LESLIE	148.28	SUPER PAY'T	16/09/93
HALLAM JODIE	758.39	SUPER PAY'T	06/06/91
HANNASKY GREGORY ROSS	244.36	SUPER PAY'T	19/04/93
HANSEN P	179.14	SUPER PAY'T	30/08/90
HANSEN RICHARD J	102.89	SUPER PAY'T	21/06/90
HAO HUU	100.50	SUPER PAY'T	11/09/91
122 THE FAIRWAY KINGSBURY 3083			
39 THE AVENUE SPOTSWOOD 3015			
20 CORSEWALL CLOSE HAWTHORN VIC 3122			
11 BOOTES ST INALA QLD 4077			
14 WILIS STREET ST ALBANS VIC 3021			
5/2 EVANS RD KEW 3101			
2 FOURTH AVE TOWNSVILLE QLD 4810			
C/O OTAHUHU POST OFFICE AUCKLAND NZ			
REGAL CARAVAN PARK WANGARATTA 3677			
8 AKARRA CRT MOOROOLOO BARK VIC 3138			
151 GORE STREET FITZROY 3065			
715 ORRONG RD TOORAK 3142			
10/2 NASH STREET GLEN IRIS VIC 346			
4 HYDRA PLACE INGSLEY WA 6026			
1 ARMADALE ST THORNBURY 3071			
25 RAYMOND ST EASTWOOD VIC 2122			
380 BAY STREET BRIGHTON 3186			
62 WHITES RAOD WARRNAMBOOL 3280			
42 CHURCH ST HASTINGS 3915			
102 DALTON RD THOMASTOWN VIC 3074			
130 SIMMAT AVE CONDELL PARK NSW 2200			
5/125 FERGUSON STREET WILLIAMSTOWN 3028			
9 BELLARINE COURT KEYSBOROUGH 3173			
6 RAYMOND AVE FLORA HILL 3550			
374 NAPIER STREET BENDIGO VIC 3550			
3/95 INDOOROPILLY RD TARINGA QLD 4068			
395 GRHAM STREET PORT MELBOURNE VIC 3207			
3 PETLOCK PL EPPING			
3/90 TUNNING STREET BRUNSWICK 3056			
P O BOX 249 FOOTSCRAY 3041			

Unclaimed Moneys Act 1962

Register of Unclaimed Moneys held by the—	Name of Owner on Books and Last Known Address	Total Amount Due to Unclaimed Owner \$	Description of Unclaimed Money	Date when Amount first became Payable
	BUSINESS FINANCIAL SERVICES—continued			
HARDING PAUL	28A NTH ST CASTLEMAIN E VIC 3450	120.51	SUPER PAY'T	09/10/93
HARGREAVES GLEN	9 MADDOCK ST FOOTSCRAY 3011	116.72	SUPER PAY'T	07/02/90
HARIF ERIC PRAANK (AMP ADF)	25 CAMBRIDGE STREET NTH CAULFIELD 3162	575.74	SUPER PAY'T	15/04/91
HARLEY ROBYN LOUISE	TARRAWARRA RD COLDSTREAM 3778	142.18	SUPER PAY'T	26/03/92
HARMAN M	4/12 DALNY ROAD MURRUMBENA 3163	463.60	SUPER PAY'T	06/07/90
HARRINGTON DARREL	20 DARREN DRIVE SLACKS CRBEK QLD 4127	160.68	SUPER PAY'T	25/11/92
HARRIS B	40 BLUE WATER CRCS BEST TWBER HEADS 2485	299.49	SUPER PAY'T	09/04/91
HARRISON D S	15 SCOTTS ROAD RIPLEY QLD 4306	129.73	SUPER PAY'T	07/08/91
HARRISON DAMIEN	48 FITZROY ST ST KILDA 3182	299.52	SUPER PAY'T	17/05/91
HARVEY BEVERLEY	PO BOX H193 AUSTRALIA SQUARE NSW 2000	1,655.07	SUPER PAY'T	19/08/93
HASLAM MR G	335 EAGLEHAWK RD EAGLEHAWK VIC 3556	966.71	SUPER PAY'T	18/01/94
HASLER WALTER	10 COLEMAN ROAD WANTIRNA 3152	365.06	SUPER PAY'T	07/11/88
HASSELL NIGEL	1/12 JULIE STREET KANGAROO FLAT 3555	156.95	SUPER PAY'T	07/04/92
HAWKINS COURT LTD (TAYLOR)	UNIT 4/107 GLOW STREET DANDENONG 3175	199.14	SUPER PAY'T	28/01/92
HAYCROFT JOHN	105 ST GEORGES TCE PERTH WA 6000	114.44	SUPER PAY'T	25/08/93
HAYES ROHAN	15/4 RICHARDSON BOULDER WA 6432	210.19	SUPER PAY'T	29/11/93
HE JI BO	8 FITZGIBBON AVB WEST BRUNSWICK 3055	200.99	SUPER PAY'T	11/04/90
HEANBY GARRY RAYMOND	150 WOOD ST PRESTON 3072	194.29	SUPER PAY'T	10/07/92
HEINES M	25 BOWMAN ST MORDIALLOC VIC 3195	229.78	SUPER PAY'T	18/01/94
HELLER COLINA	24 DUNEARN ROAD NTH DANDENONG 3174	131.75	SUPER PAY'T	11/01/91
HEMEN ANTUN (AMP PERS SUPER)	46 CARLSLE STREET INGLEBURN NSW 2565	329.93	SUPER PAY'T	12/10/90
HENDERSON DARREN	219 ICEIGUTLEY RD EAST SHEPTON PARK WA 6008	392.77	SUPER PAY'T	18/01/94
HENDERSON JASON	140 ST GEORGES TCE PERTH WA 6000	392.77	SUPER PAY'T	29/11/93
HENMAN KIM MARBB	4/95 HOFFMANS RD NIDDRIE 3042	151.25	SUPER PAY'T	29/04/91
HENNESSY RONALD JOHN	90 GREENWOOD DRIVE LAUNCHING PLACE 3139	123.91	SUPER PAY'T	04/12/90
HENRY EDWARD	1 REGINA RD KELMSCOTT WA 6111	141.73	SUPER PAY'T	21/10/93
HEPBURN PAUL	3 HUNTER STREET MORNINGTON 3931	196.53	SUPER PAY'T	06/08/91
	PO BOX 234 KATHERINE NT 0851	609.57	SUPER PAY'T	29/12/93
	153 WINCHESTER ST LEVIN NORTH ISLAND NZ 3000	228.60	SUPER PAY'T	03/06/92
	123 GISBORNE ROAD MELTON 3337	521.53	SUPER PAY'T	07/08/91

Unclaimed Moneys Act 1962

Register of Unclaimed Moneys held by the—

Name of Owner on Books and Last Known Address	Total Amount Due to Owner	Description of Unclaimed Money	Date when Amount first became Payable
BUSINESS FINANCIAL SERVICES—continued			
HERBERT STEVE	150.28	SUPER PAY'T	17/06/91
HERMAN P J	243.36	SUPER PAY'T	01/09/92
HERNANDEZ PAUL	106.20	SUPER PAY'T	28/05/91
HERNANDEZ PAUL	3,833.75	SUPER PAY'T	17/04/91
HEY ROSEMARY ANNE	120.40	SUPER PAY'T	09/05/90
HIGGINBOTTOM MARK	157.06	SUPER PAY'T	21/09/93
HILL GARY	247.15	SUPER PAY'T	19/07/93
HILTON PHILLIP JOHN	177.79	SUPER PAY'T	28/02/91
HINTON ROBBIE	110.57	SUPER PAY'T	14/06/91
HOBBS M J	147.25	SUPER PAY'T	15/08/90
HOLLAND ROBERT CHARLES	152.14	SUPER PAY'T	26/10/93
HOLLOWAY A R	191.56	SUPER PAY'T	03/03/92
HOPA GERRY	206.93	SUPER PAY'T	25/10/91
HORE NEIL W	184.06	SUPER PAY'T	28/04/93
HORNE STEPHEN	135.93	SUPER PAY'T	29/10/90
HORSLEY MEREDITH	118.29	SUPER PAY'T	21/09/93
HRYGAIKIS GUSTAV	225.95	SUPER PAY'T	22/07/91
HUANG DIAN WU	646.28	SUPER PAY'T	30/08/91
HUANG TRAN	251.89	SUPER PAY'T	20/09/93
HUMPHRIES EDWARD C	217.97	SUPER PAY'T	24/05/93
HUNG LAM CHUK	131.75	SUPER PAY'T	10/06/92
HUNT JACQUELINE	152.58	SUPER PAY'T	13/08/93
HUNTER MR J	161.67	SUPER PAY'T	20/10/93
HUNTER SCOTT BRADLEY	269.63	SUPER PAY'T	20/11/89
HUTCHINSON BARRY JAMES	256.20	SUPER PAY'T	18/01/94
HUTCHINSON MARGARET	537.22	SUPER PAY'T	20/10/93
HUTTON TIM	127.67	SUPER PAY'T	09/12/91
HUTTON MOYA	140.44	SUPER PAY'T	29/07/91
HUYNH PHIA	292.90	SUPER PAY'T	25/06/91
	249.84	SUPER PAY'T	05/06/92
59 JONES RD DANDENONG 3175			
C/ D & S HAMILTONS MEATS P O BOX 152 HAMILTON			
84/11 GREEVES ST FITZROY 3065			
84/11 GREEVES STREET FITZROY 3065			
20 RIVER STREET BRIOR HILL VIC 3088			
11 INA CLOSE CRAIGMORE SA 5114			
474 CALLANDER RD NOBLE PARK VIC 3174			
10 SILVIA ST LOWER TEMPLESTOWE 3107			
24/1 ALSOP CLOSE SWINGER HILL ACT 2607			
10 MT EAGLE WAY WERRIBEE 3030			
25 GLAMORGAN ST EAST CANNINGTON WA 6107			
8 TREVINO CLOSE HOPPERS CROSSING 3030			
418 UPPER AVENUE MOSMAN NSW 2088			
3/175 BURT ST KALGOORLIE WA 6430			
3 KYRIE CRT CARRUM DOWNS 3102			
66 LEROY RD ACACIA RIDGE QLD 4110			
1/3 CANBERRA ST TOORAK 3142			
4 HANSEN STREET MT WAVERLEY 3149			
5/26 KELVINGTON RD NOBLE PARK VIC 3174			
363 CENTRE DANDENONG RD HEATHERTON VIC 3202			
31 JUDGE STREET SUNSHINE VIC 3020			
61 MAN STREET WOODSIDE SA 5244			
3/101 GIFTS ST EAST MELBOURNE VIC 3002			
3/14 GOWER STREET PRESTON 3072			
LOT 26 TEASDALE ST YARLOOP WA 6218			
RMB 2205 BOORCAN VIC 3264			
65 BAYVIEW STREET PRAHRAN 3181			
1/437 FLEMINGTON RD NTH MELBOURNE 3051			
15 JOHNS CRT NARREN WARREN 3805			
50 KETT STREET NUNAWADING 3131			

Unclaimed Moneys Act 1962

Register of Unclaimed Moneys held by the—

Name of Owner on Books and Last Known Address	Total Amount Due to Owner	Description of Unclaimed Money	Date when Amount first became Payable
BUSINESS FINANCIAL SERVICES—continued			
HUYNH ON	213.22	SUPER PAY'T	10/08/89
HUZONY R	114.80	SUPER PAY'T	06/05/91
HYNDMAN H P	200.35	SUPER PAY'T	09/10/90
IBARRA MARY	101.32	SUPER PAY'T	23/06/93
ILIOPOULOS T	479.96	SUPER PAY'T	12/04/90
IRELAND KYLIE	160.84	SUPER PAY'T	28/06/93
IRVING ROSS FRANCIS	218.28	SUPER PAY'T	20/12/90
J G BLACK PTY LTD	381.52	SUPER PAY'T	01/04/93
JACKA MICHAEL	130.77	SUPER PAY'T	30/11/91
JACKSON MR KARL	464.22	SUPER PAY'T	22/06/93
JACOBS JODIE	130.20	SUPER PAY'T	07/10/93
JAENKE BRUCE	109.93	SUPER PAY'T	14/01/93
JAMES CRAIG	126.26	SUPER PAY'T	16/05/91
JANSEN JOANNA MARIA	230.26	SUPER PAY'T	05/05/92
JARLETT ADAM LESLIE	269.62	SUPER PAY'T	27/01/93
JAVAD KHALID	146.63	SUPER PAY'T	08/02/91
JENKINS MARK	196.10	SUPER PAY'T	22/07/91
JEPSON GORDON	258.33	SUPER PAY'T	12/08/91
JOHNSTON LEON	489.25	SUPER PAY'T	29/04/91
JONES K B	254.96	SUPER PAY'T	28/05/93
JONES WILLIAM FRANCIS	102.35	SUPER PAY'T	13/11/91
JORDAN D	130.91	SUPER PAY'T	05/12/90
JOY CHRISTINE	293.27	SUPER PAY'T	15/11/93
JULIN DALE SCOTT	107.68	SUPER PAY'T	05/03/91
JUNKERS MICHAEL W	206.87	SUPER PAY'T	02/01/92
KAFRITOGAS LUCY	155.27	SUPER PAY'T	02/12/93
KALLIAROPOULOS VASSILIOS	155.70	SUPER PAY'T	23/09/92
KALLIAROPOULOS THEODORA	420.23	SUPER PAY'T	26/08/92
	176.67	SUPER PAY'T	31/03/92
	135.48	SUPER PAY'T	31/03/92
6/1 KOKARIBB RD CARNEGIE 3163			
3/24 AVENUE SPRINGVALE 3171			
13 HAWKB ST WEST MELBOURNE 3003			
1 HOLMES RD MOONEB PONDS VIC 3000			
15 ROSE AVE SPRINGVALE 3171			
10/11A ORMOND ESPLANADE ELWOOD VIC 3184			
33 WHITE ST MORDIALLOC 3195			
221 PELHAM STREET CARLTON VIC 3053			
C/O COUNCIL FOR CHRISTIAN EDUCATION 4TH FL 130 LOT 6 WALLABY HOTS RD PALMERSTON NT 0830			
1/111 MELVILLE RD WEST BRUNSWICK VIC 3055			
1/12 SAFFORD ST NORTHGATE QLD 4013			
203 CRESWICK RD BALLARAT 3500			
8 FRUDAL CRES KNOXFIELD 3180			
6 CHAPMAN AVENUE THOMASTOWN 3074			
32/5 GOOD ST WESTMEAD 2145			
13 BUNALBO AVENUE STH YARRA 3141			
16 LIMA STREET HOMEVIEW OLD 4027			
14 YENNORA COURT KBYSBOROUGH 3173			
1/305 STATION STREET FAIRFIELD VIC 3076			
8 CAMERON ST RICHMOND 3121			
19/343 BEACONSFIELD PDB ST KILDA 3182			
23 DOEKER ST RICHMOND VIC 3121			
47 CRESTDALE AVE WANTIRNA 3152			
UNIT 5 201 HIGH ST BERWICK 3806			
283A OGILVIE AVE ECHUCA VIC 3564			
LKA-50 GALLIPOLI RD COFFS HARBOUR NSW 2450			
50 CUTHBERT ST BROADMEADOWS			
7/77 WAITLETREE RD MALVERN 3144			
7/77 WAITLETREE RD MALVERN 3144			

Unclaimed Moneys Act 1962

Register of Unclaimed Moneys held by the—

Name of Owner on Books and Last Known Address	Total Amount Due to Owner \$	Description of Unclaimed Money	Date when Amount first became Payable
BUSINESS FINANCIAL SERVICES—continued			
KANAFTYPILLAIR STEVEN SIVA	224.70	SUPER PAY'T	22/08/91
KARAMIKOS	324.99	SUPER PAY'T	24/09/90
KARVANOS NICHOLAS	113.09	SUPER PAY'T	05/11/93
KATSARAS VICKI	1,877.75	SUPER PAY'T	11/06/93
KAZANE YASAR	370.86	SUPER PAY'T	22/01/91
KEANE URSULA ANN	118.98	SUPER PAY'T	26/11/93
KEAVENBY HELEN	131.67	SUPER PAY'T	13/07/92
KELETT PETER	153.28	SUPER PAY'T	04/07/91
KEELY B	725.22	SUPER PAY'T	04/01/91
KENDALL PAUL JAMES	143.28	SUPER PAY'T	12/01/94
KENNIDY PHILLIPA JANE	285.34	SUPER PAY'T	20/11/92
KER NANCY	254.63	SUPER PAY'T	10/09/93
KERR CAMERON	121.04	SUPER PAY'T	08/10/93
KHAN MOHAMMED SANAUULLA	196.18	SUPER PAY'T	01/07/92
KILIE MEHMET	208.64	SUPER PAY'T	30/06/92
KING ANN RADCLIFFE	102.58	SUPER PAY'T	21/12/93
KING JULIE SONIA MARIE	123.37	SUPER PAY'T	11/09/92
KIRBY ANNE	211.97	SUPER PAY'T	02/11/91
KIRIC ELTON	103.96	SUPER PAY'T	10/09/93
KIRKHAM CHERYL LYN	247.02	SUPER PAY'T	26/11/91
KISHORE USHA	220.24	SUPER PAY'T	18/01/94
KITCHEN LEE ANNE	207.84	SUPER PAY'T	21/10/92
KIWI MICHELLE RENEE	104.70	SUPER PAY'T	19/08/93
KLAASSEN LAMBERTUS	102.55	SUPER PAY'T	09/11/93
KNEESE GREGORY KENNETH	157.85	SUPER PAY'T	06/01/94
KOLONIECKI BOGUHIL	118.95	SUPER PAY'T	18/01/94
KONINGS K	342.03	SUPER PAY'T	24/01/91
KONTOIS GEORGE	223.78	SUPER PAY'T	15/10/92
KOVANK ERIN	261.43	SUPER PAY'T	29/11/90
KRANZ RACHEL MAIRIE	1,104.96	SUPER PAY'T	15/07/93

Name of Owner on Books and Last Known Address

Unclaimed Moneys Act 1962

Register of Unclaimed Moneys held by the

Name of Owner on Books and Last Known Address	Description of Unclaimed Money	Total Amount Due to Owner	Date when Amount first became Payable
KRENN G A	SUPER PAY'T	106.63	28/12/90
KRETSCH WILFRED	SUPER PAY'T	127.50	07/05/87
LADAS MANUEL	SUPER PAY'T	214.64	22/09/92
LADIGES F	SUPER PAY'T	376.05	07/03/91
LAMB MARK IAN	SUPER PAY'T	227.22	18/01/94
LAMBERT CRAIG	SUPER PAY'T	103.70	27/08/93
LANDRIGAN ELAINE	SUPER PAY'T	160.26	29/11/91
LANGHANS PETER	SUPER PAY'T	212.61	13/08/92
LAUBE GRANT	SUPER PAY'T	117.53	17/10/91
LAUGHTON ANDREW	SUPER PAY'T	213.25	13/09/91
LAYSICO TERESITA	SUPER PAY'T	260.45	06/08/93
LE NEPVEU MR RODNEY MARK	SUPER PAY'T	102.22	10/01/90
LEAHY JOSEPH PETER	SUPER PAY'T	209.00	25/11/93
LEE MICHELLE B	SUPER PAY'T	102.53	15/04/92
LEE MISS VINNIE	SUPER PAY'T	137.25	28/02/90
LEE P	SUPER PAY'T	161.33	26/04/91
LENAKT TADEUSZ	SUPER PAY'T	851.41	13/04/92
LENIHAN SEAN	SUPER PAY'T	145.61	23/07/93
LESAR K	SUPER PAY'T	265.63	28/05/91
LESLIE MALCOM	SUPER PAY'T	109.94	28/05/92
LESLIE MICHAEL G	SUPER PAY'T	128.00	29/05/92
LEWIS GARY	SUPER PAY'T	135.95	08/01/91
LI B	SUPER PAY'T	131.76	10/09/90
LI MICHEAL	SUPER PAY'T	102.74	01/09/93
LI ZI YU	SUPER PAY'T	136.02	08/01/91
LIAM PATRICK	SUPER PAY'T	204.63	22/05/91
LILLICRAPP ANNA LOUISE	SUPER PAY'T	123.63	31/10/90
LIN TAO	SUPER PAY'T	164.97	08/10/91
LINCOLN KAREN ALICE	SUPER PAY'T	299.21	22/03/91
LINE I R	SUPER PAY'T	239.57	21/11/90

BUSINESS FINANCIAL SERVICES—continued

LOT 2 OLD GIPPSLAND RD LILYDALE 3140			
2 OLIVIERI CRES GREEN VALLEY NSW 2170			
78 MARGOLD AVENUE ALTONA 3018			
3/9 SARGOOD ST ALTONA 3018			
704 WANNEROO RD WANNEROO WA 6065			
4 CARLISLE STREET SHEPPARTON VIC 3630			
40 CHURCH ST NTH FITZROY 3068			
6 ALEXANDER AVE CRANBOURNE 3977			
193 STATION STREET EDITHVALE 3196			
LOT 17 GLADYS ROAD CARRUN DOWNS 3201			
6/18 RIDLEY STREET SUNSHINE VIC 3020			
3 MORTON ST FRANKSTON			
43 YALDWIN ST WEST KYNETON VIC 3444			
2/49 DUKE ST CASTLEMAINE 3450			
9/44 WATERLOO CRES ST KILDA 3182			
4 FLETCHER PLACE DAVIDSON 2045			
12 SMITHSON COURT DANDENONG 3175			
3/45 LIGAR STREET SUNBURY VIC 3429			
82 MOLLISON ST NOBLE PARK 3179			
164 NEPEAN HIGHWAY SEAFORD 3198			
121 CRANBOURNE RD FRANKSTON 3199			
3/1 TAPAROO RD TEMPLESTOWE 3106			
10/629 ASCOT VALE RD MOONEE PONDS 3039			
18/65 WAREN RD MARRICKVILLE NSW 2204			
22/252 MORELAND RD BRUNSWICK 3056			
P O BOX 282 DAYLESFORD 3460			
6/67 BALHAM AVENUE KINGSWOOD SA 5062			
37 CAMERON STREET RICHMOND 3121			
5/23 DAVENPORT TCE WAYVILLE SA 5034			
21 IVAN ST NOTH FITZROY 3068			

Unclaimed Moneys Act 1962

Register of Unclaimed Moneys held by the—

Name of Owner on Books and Last Known Address	Total Amount Due to Owner of Unclaimed Money	Description of Unclaimed Money	Date when Amount first became Payable
BUSINESS FINANCIAL SERVICES—continued			
LISTER NICOLE	366.90	SUPER PAY'T	13/07/92
LIU PING	182.52	SUPER PAY'T	23/10/91
LIVERSIDGE DANIEL	153.52	SUPER PAY'T	30/01/92
LOGAN I	750.09	SUPER PAY'T	30/09/88
LOLLER STEVEN	219.04	SUPER PAY'T	12/11/90
LOMAS K	157.46	SUPER PAY'T	11/06/91
LOMONT GRAHAM PETER	160.38	SUPER PAY'T	13/05/92
LOWE JEREMY	167.76	SUPER PAY'T	08/06/93
LOWRY JAMIE CHRISTIAN	171.62	SUPER PAY'T	26/11/91
LU YAN YUN	133.52	SUPER PAY'T	25/06/91
LU ZUAN YAN	110.29	SUPER PAY'T	18/01/94
LUCKETT IAN	155.77	SUPER PAY'T	21/02/91
LUDWIG MARK	255.51	SUPER PAY'T	26/11/93
LUMLEY P J	263.80	SUPER PAY'T	30/07/90
LUSCOMBE GEOFFREY PHILLIP	249.36	SUPER PAY'T	07/05/93
LYNCH S C	140.99	SUPER PAY'T	04/02/92
LYONS P	1,315.45	SUPER PAY'T	11/01/91
LYONS R	189.65	SUPER PAY'T	15/03/91
MA HONG JUN	180.01	SUPER PAY'T	20/09/93
MA KHAC HUG	216.22	SUPER PAY'T	25/02/92
MAKA REGINALD	183.78	SUPER PAY'T	26/05/93
MACLAREN DINAH	200.19	SUPER PAY'T	06/03/92
MACPHERSON SMITH SONIA	106.71	SUPER PAY'T	06/12/91
MACQUARIE CHRISTINA H	243.22	SUPER PAY'T	06/06/91
MADIGAN SIMON SHANE	106.79	SUPER PAY'T	22/11/93
MADON M	246.78	SUPER PAY'T	25/04/91
MAHER DAVID	208.35	SUPER PAY'T	20/06/93
MAHER DAVID JOHN	127.61	SUPER PAY'T	03/06/92
MAISANO BEN	235.81	SUPER PAY'T	04/07/91
MALONEY P J	147.65	SUPER PAY'T	19/03/92

Unclaimed Moneys Act 1962

Name of Owner on Books and Last Known Address	Total Amount Due to Owner \$	Description of Unclaimed Money	Date when Amount first became Payable
MALUJA STUART	187.76	SUPER PAY'T	06/11/92
MANAGIE JANIE A	104.78	SUPER PAY'T	28/09/92
MANOS BETTY	168.33	SUPER PAY'T	18/07/90
MANSFIELD DARLENE LEB	622.25	SUPER PAY'T	21/07/93
MARLOW MICHAEL	211.74	SUPER PAY'T	30/07/92
MARRIOT PHILLIP JOHN	137.33	SUPER PAY'T	25/06/93
MARSHALL B R	223.92	SUPER PAY'T	17/07/90
MARSHALL DAVID	278.35	SUPER PAY'T	19/07/93
MARSHALL RODNEY JAMES	129.98	SUPER PAY'T	25/11/93
MARTIN CHRISTOPHER	153.71	SUPER PAY'T	22/01/92
MARTIN MARIA	1,568.10	SUPER PAY'T	20/08/92
MARTIN NEIL ALLAN	178.70	SUPER PAY'T	04/06/92
MARTINA RITA	111.33	SUPER PAY'T	16/01/92
MASB PETER PAUL	276.26	SUPER PAY'T	30/07/90
MASON A D	212.74	SUPER PAY'T	12/05/93
MASON GEOFFREY	498.95	SUPER PAY'T	19/12/90
MATEJIN D	142.79	SUPER PAY'T	17/06/93
MAYBERRY COLIN	194.08	SUPER PAY'T	27/05/91
MAYNARD JOSEPH JAMES	240.59	SUPER PAY'T	11/09/90
MCLEOD TANYA MICHELLE	102.55	SUPER PAY'T	16/07/93
MCCAFFEY ELIZABETH	211.14	SUPER PAY'T	30/06/92
MCCONVILLE A	241.21	SUPER PAY'T	28/09/93
MCDERMID C J	151.42	SUPER PAY'T	22/07/91
MCDONALD IAN LAWRENCE	154.92	SUPER PAY'T	10/10/91
MCFARLANE PETER	633.34	SUPER PAY'T	07/08/90
MCGARRY TAMMY KEITH	555.93	SUPER PAY'T	28/03/91
MCGOWAN SCOTT	248.40	SUPER PAY'T	18/01/94
	189.13	SUPER PAY'T	21/07/90
	230.99	SUPER PAY'T	20/03/91
		SUPER PAY'T	14/10/93

BUSINESS FINANCIAL SERVICES—continued

C/- AMPOL CARAVAN PARK DELTA BOWEN QLD 4805			
5 LOCKLEY ST GLENROY 3046			
149 MILLS ST MIDDLE PARK 3206			
68 CHEFLEY DRIVE PRESTON VIC 3072			
21 RIVERVIEW TCE INDOOROPILLY QLD 4068			
7 DOUGLAS STREET FERRYDEN PARK SA 5014			
18 SEYCHELLES SHORHAM 3271			
53 BOX ST DOVETON VIC 3177			
C/- KALGOORLIE CPARK KALGOORLIE WA 6430			
7 EDNER STRBET EAST MALVERN 3145			
100 DRUMMOND ST COU HON 3053			
15/642 SWANSTON ST CARLTON 3053			
41 CLYDE STRBET THORNBURY 3071			
C/O ELPIN CONT'L KNITWEAR P O BOX 522 BOX HILL			
17 BEAUTY GULLY RD WARRANDYTH VIC 3113			
99 CHIRNSIDE AVENUE WERRIBEE 3030			
68 STAUGHTON RD GLEN IRIS VIC 3146			
418 BARKLY ST FOOTSCRAY 3011			
41 SMITHS ROAD TEMPLESTOWE 3106			
100 HETTON STREET GOLDEN SQUARE VIC 3555			
UNIT 2 219 MAHONEY'S RD FOREST HILL 3131			
4/43 OSBORNE AVE GLEN IRIS VIC 3146			
15 ARGYLE STREET MACLEOD 3085			
30 STANDISH AVE OAKHURST 2770			
4 KBEROK AVENUE SEAFORD 3198			
1/35 HEATHER ST WILSTON QLD 4051			
45 BANNISTER RD PADBURY WA 6025			
22 ROSE ST SURREY HILLS 5127			
35 FRANHAM ST FLEMINGTON 3031			
LOT 602 CROYDON HILLS DR CROYDON VIC 3136			

Unclaimed Money Act 1962

Register of Unclaimed Money held by the—

Name of Owner on Books and Last Known Address	Total Amount Due to Owner	Description of Unclaimed Money	Date when Amount first became Payable
BUSINESS FINANCIAL SERVICES—continued			
MCINTOSH P	243.70	SUPER PAY'T	12/06/91
MCKEYVER STEPHEN ANDREW	411.66	SUPER PAY'T	22/04/88
MCKENNA ROADNEY	170.09	SUPER PAY'T	31/01/92
MCLAREN IAN JOHN	111.24	SUPER PAY'T	04/11/93
MCLAUGHLIN PAUL JAMES	170.03	SUPER PAY'T	07/11/91
MCLAUGHLIN TREVOR HENRY	135.26	SUPER PAY'T	08/02/91
MCMATHCH GLEN PATRICK	191.08	SUPER PAY'T	30/07/91
MCMASTER TREVOR ROYCE	382.50	SUPER PAY'T	16/07/91
MCNAMARA SHARON LOUISE	183.06	SUPER PAY'T	24/10/91
MCPHER P	197.75	SUPER PAY'T	13/05/91
MELEMBIS ANGELO	107.76	SUPER PAY'T	29/03/93
MELOURY CHRIS MARK	147.66	SUPER PAY'T	28/09/92
MERCHANT TRACY MEGAN	179.01	SUPER PAY'T	03/06/93
MERINO NELLO ANTHONY	124.41	SUPER PAY'T	06/06/90
METLIKA MORRIS	130.95	SUPER PAY'T	16/09/92
MICALLEP MICHAEL ANGELO	122.99	SUPER PAY'T	11/01/94
MICALLER V	198.61	SUPER PAY'T	10/12/90
MIDDLETON MICHAEL	332.85	SUPER PAY'T	23/12/92
MIDDLELING MAISIE	130.72	SUPER PAY'T	28/04/92
MIETZ A	261.80	SUPER PAY'T	19/04/90
MIHAI PREDRAG	172.68	SUPER PAY'T	25/10/91
MILTANTB DENNIS	250.94	SUPER PAY'T	20/02/92
MILLER P J	225.81	SUPER PAY'T	18/09/90
MILLER PAUL	119.50	SUPER PAY'T	18/01/94
MOGHANI P	136.91	SUPER PAY'T	04/01/91
MOHONEY D P	121.80	SUPER PAY'T	14/01/91
MOLLOY ANDREW M	332.51	SUPER PAY'T	04/12/88
MOODY KELLIE	136.69	SUPER PAY'T	15/04/92
MORAL KAZIM	200.54	SUPER PAY'T	19/08/92
MORBY PATRICK WILLIAM	126.99	SUPER PAY'T	29/04/92

Unclaimed Moneys Act 1962

Register of Unclaimed Moneys held by the—

Name of Owner on Books and Last Known Address	Total Amount Due to Owner	Description of Unclaimed Money	Date when Amount first became Payable
BUSINESS FINANCIAL SERVICES—continued			
MORGAN SHERRIE	107.65	SUPER PAY'T	27/09/93
MORLEY AMANDA LOUISE	127.48	SUPER PAY'T	29/06/93
MORRISON GEOFFREY	233.29	SUPER PAY'T	18/01/94
MOSS HEATHR ELSIE	172.60	SUPER PAY'T	04/05/93
MOSS GREGORY	477.99	SUPER PAY'T	20/12/93
MOUTY ROBIN	162.74	SUPER PAY'T	15/12/92
MULLINS PAUL	122.08	SUPER PAY'T	22/06/93
MUNDY GHOFF P	14.93	SUPER PAY'T	10/05/93
MURDOCH GRAHAM	166.38	SUPER PAY'T	29/07/92
MURRAY ANGELA JANE	174.70	SUPER PAY'T	23/09/91
MURRAY NEVILLE BRIAN	182.92	SUPER PAY'T	29/07/93
MURRIMAL BASIL	128.27	SUPER PAY'T	18/01/94
MYNARD PAUL	155.91	SUPER PAY'T	22/07/93
NASTESKA VASILKA	130.32	SUPER PAY'T	06/08/91
NEISH STEVEN	105.52	SUPER PAY'T	28/02/92
NELSON ANNETTE	111.32	SUPER PAY'T	16/04/91
NEWAJ DINESH	186.62	SUPER PAY'T	11/06/91
NEWSON SHANE FRANCIS	135.75	SUPER PAY'T	21/10/93
NEWTON KIM	343.88	SUPER PAY'T	19/07/93
NGAHA DENNIS RICHARD	165.07	SUPER PAY'T	20/11/92
NGUYEN HOA	227.84	SUPER PAY'T	21/05/92
NGUYER NGOC HOA	122.56	SUPER PAY'T	23/10/90
NGUYER THANH BINH	238.97	SUPER PAY'T	21/01/92
NGUYER THANH VAN	258.59	SUPER PAY'T	20/09/91
NOLAN J	109.76	SUPER PAY'T	20/07/90
NOLAN PAULA	205.53	SUPER PAY'T	22/08/91
NOONAN A P	337.15	SUPER PAY'T	24/05/90
NORRIS G J	306.12	SUPER PAY'T	18/02/91
NOVACIC SASHA	495.40	SUPER PAY'T	03/01/92
NOVAKOVIC MARIE	140.76	SUPER PAY'T	01/11/93

Unclaimed Money Act, 1962

Register of Unclaimed Money held by the—

Name of Owner on Books and Last Known Address	Total Amount Due to Owner	Description of Unclaimed Money	Date when Amount first became Payable
BUSINESS FINANCIAL SERVICES—continued			
NUTTING GREG MERYEN	105.07	SUPER PAY'T	28/05/91
O'BRIEN PATRICK JOHN	114.93	SUPER PAY'T	03/05/93
O'CONNELL SHIRLEY ANN	376.74	SUPER PAY'T	30/05/91
O'DWYER PATRICIA MARY	101.09	SUPER PAY'T	01/12/92
O'LEARY LOUISE	115.98	SUPER PAY'T	03/02/92
O'NEIL JOHN TERENCE	250.66	SUPER PAY'T	27/07/92
OAKENFULL N L	198.66	SUPER PAY'T	16/10/91
OCON PRISCILLA	201.03	SUPER PAY'T	10/01/93
OKRAY NIHAL	235.16	SUPER PAY'T	07/01/94
OLEKSYN DEBORAH	224.02	SUPER PAY'T	16/09/92
OLERHEAD I	129.87	SUPER PAY'T	09/04/91
ONG STEVEN BAN YONG	214.26	SUPER PAY'T	04/12/92
ORTON DIANA	162.61	SUPER PAY'T	08/01/91
OSWALD GARY LEE	199.24	SUPER PAY'T	27/03/91
OTIMI MICHELLINA	185.85	SUPER PAY'T	30/06/93
OVERS MURRAY	150.00	SUPER PAY'T	24/12/93
OWEN LEIGH MATTHEW	160.04	SUPER PAY'T	20/06/89
OZGAN OSMAN	1,144.42	SUPER PAY'T	10/09/93
P D RETIREMENT FUND	210.64	SUPER PAY'T	29/05/91
PA HOBUN	124.61	SUPER PAY'T	22/10/92
PACKER DAVID JOHN	166.50	SUPER PAY'T	28/06/91
PACKERS SUNRAYSHIA	121.83	SUPER PAY'T	25/09/92
PANLOCK MARK TERRY	122.93	SUPER PAY'T	03/06/88
PAPPAS LORRAINE	171.71	SUPER PAY'T	09/04/87
PARKER KAREN	236.12	SUPER PAY'T	29/04/93
PARKER TANYA MICHELLE	172.81	SUPER PAY'T	07/12/89
PARTINGTON J	136.65	SUPER PAY'T	28/05/93
PASINIS ATHENA	112.10	SUPER PAY'T	08/05/91
PATRICK LIAM	121.76	SUPER PAY'T	10/12/90
			21/05/91
PO BOX 1293 EAST DONCASTER 3109			
REAR 113 GLENFERRIE RD MALVERN VIC 3144			
57 COUNCIL STREET DONCASTER 3108			
9 GEAROE ST KILMORE VIC 3764			
4/1263 HIGH STREET MALVERN 3144			
91 CANTERBURY ROAD KILSYTH 3137			
24 GRAIG RD DONVALE 3111			
C/- 2 DUKE ST WINDSOR VIC 3181			
16 KOROIT AVE DALLAS VIC 3047			
21 WIRILDA CREB NTH FRANKSTON 3200			
35 JACKA ST WEST PRESTON 3078			
1 ROBERTSON CREB LAVERTON VIC 3028			
KERLEITH PARK GARSTEAD 3737			
PLAT 3 45 CHURCHILL AVE ASCOTT VALE 3032			
1/130 WELLINGTON STREET MOSMAN PARK WA 6012			
172 MAIDSTONE ST ALTONA VIC 3018			
LOT 4 GRISBORNE RD TOOLERN VALE 3337			
45 HILLSIDE GROVE AIRPORT WEST VIC 3042			
1/42 KING ST BROADMEADOWS 3047			
1/10-12 ROKER ST CRONULLA POINT NSW 2230			
12 BACKOUS WAY NOBLE PARK 3174			
9/64 CARRINGTON PARADE NSW 2096			
BOX CP 34 MILDURA 3500			
25 ILUKA ST SAFETY BEACH VIC 3936			
29 EXCEKSUIR AVE CASTLE HILL NSW 2154			
13 CHILDS ST MELTON STH 3337			
78 BELLBIRD RD MT ELIZA VIC 3930			
4/12 WOODMASON ST BORONIA 3155			
4 AMSTEL ST CRAIGIEBURN 3083			
69 PALMERSTON ST BERWICK 3806			

Unclaimed Moneys Act 1962

Register of Unclaimed Moneys held by the—

Name of Owner on Books and Last Known Address	Total Amount Due to Owner	Description of Unclaimed Money	Date when Amount first became Payable
BUSINESS FINANCIAL SERVICES—continued			
PAYLIMA GIOVANNI	102.61	SUPER PAY'T	30/07/90
PAYNE J C	24.75	SUPER PAY'T	17/05/91
PEACOCK KEVIN DEREK	283.65	SUPER PAY'T	18/03/93
PECK GRAHAM EDWARD	121.03	SUPER PAY'T	19/02/93
PEIRCE NICOLE JANELLE	618.15	SUPER PAY'T	27/08/93
PENNINGTON DIANNE MARY	115.02	SUPER PAY'T	18/08/93
PENTECAST KIM NARELLE	270.08	SUPER PAY'T	18/03/93
PEREZ JULIE	393.50	SUPER PAY'T	16/02/89
PERKOVIC	137.63	SUPER PAY'T	26/01/91
PERL ANDREW	420.80	SUPER PAY'T	16/04/93
PETERS J	227.39	SUPER PAY'T	22/04/91
PETROU MICHAEL CHARLES	153.16	SUPER PAY'T	17/12/92
PETROVIC BANISLAV	136.60	SUPER PAY'T	02/08/93
PETTIT STANLEY CHARLES	185.59	SUPER PAY'T	08/12/93
PHAM VANPHY	116.53	SUPER PAY'T	23/10/91
PHAN MINH NEUNG	336.05	SUPER PAY'T	23/01/92
PICOT MARK	796.00	SUPER PAY'T	22/12/93
PITCHES RACHAEL ANN	267.68	SUPER PAY'T	17/11/93
PIZZICA SERGIO	141.92	SUPER PAY'T	28/01/92
POLLARD SHANE	182.93	SUPER PAY'T	10/08/93
POLLITT PAULINE ROSEMARIE	153.24	SUPER PAY'T	18/01/94
POLOAI TUA LAUNIA	206.54	SUPER PAY'T	18/01/94
PONCE RAPHAEL	208.08	SUPER PAY'T	06/02/91
POPATA SHANE	111.49	SUPER PAY'T	23/10/90
PORTER CLAYTON	225.94	SUPER PAY'T	16/03/92
PORTER D R	137.67	SUPER PAY'T	21/04/93
POTTON PAUL E	292.65	SUPER PAY'T	15/07/91
POWELL RICK EDWARD	103.95	SUPER PAY'T	18/01/94
POWER B J	120.05	SUPER PAY'T	17/01/94
	476.67	SUPER PAY'T	08/10/90
O/O HELPIN CONT'L KNITWEAR P O BOX 522 BOX HILL			
1/118 PRINCES HWY DANDENONG 3175			
26 BAITMAN STREET FITZROY NTH VIC 3068			
PATHO SCHOOL RD PATHO VIC 3564			
19 MCCOLL STREET BENDIGO VIC 3550			
HORTON ST FORT MACQUARIE NSW 2444			
4/38 CHAPMAN ST GYMEA NSW 2227			
25 DUDLEY ST LIDCOMBE NSW 2141			
30 LAROO ST WEST SUNSHINE 3020			
4 RYAN STREET RESERVOIR VIC 3073			
5 MILNE ST MITCHAM 3132			
3 COLERIDGE DRIVE SYDENHAM VIC 3038			
24 NAPIER ST FITZROY VIC 3065			
SITE 58 78 WINDSOR GVE WINDSOR GARDENS SA			
58/2 SIMMONS ST SOUTH YARRA 3141			
120 RACECOURSE ROAD FLEMINGTON 3031			
30 MARTHAS CRES MT PLEASANT NSW 2749			
6 PORT ROYAL DVE MALLIBU WA 6168			
8 LINDSAY STREET GLENROY 3046			
11/242 PASCOE VALE RD ESSENDON VIC 3040			
6/15 ELMHURST RD BAYSWATER VIC 3153			
11 ERNEST ST BAYSWATER VIC 3153			
247 HEIDELBERG RD CLIFTON HILL 3068			
3/79 MCBURNEY RD CABRAMATTA NSW 2166			
88 WIDFORD ST GLENROY 3046			
17 DRIVER WAY BULLCREEK WA 6149			
161 WARILDA AVENUE BENGADINE NSW 2233			
1/97 KING ST BENDIGO VIC 3550			
29 MORAY ST DIAMOND CREEK VIC 3089			
41 TYAU ST MOONTA SA 5558			

Unclaimed Money Act 1962

Register of Unclaimed Money held by the—

Name of Owner on Books and Last Known Address	Total Amount Due to Owner	Description of Unclaimed Money	Date when Amount first became Payable
POWER D	878.21	SUPER PAY'T	18/12/90
POWER KIM M	728.51	SUPER PAY'T	12/05/93
POZZI TONY	906.47	SUPER PAY'T	20/08/93
PRATT BARRY	122.24	SUPER PAY'T	30/04/91
PRATT J C	247.38	SUPER PAY'T	27/02/91
PRERADOVIC HEIDI VICTORIA	199.38	SUPER PAY'T	30/06/92
PRESLEY DARREN	144.53	SUPER PAY'T	16/09/92
PRESNELL JAMIE	451.57	SUPER PAY'T	10/09/93
PRESTON FRANCIS	220.06	SUPER PAY'T	08/01/91
PRESTON H R	109.11	SUPER PAY'T	18/06/90
PRICE R	198.62	SUPER PAY'T	29/08/90
PRIME A J	185.26	SUPER PAY'T	18/09/90
PROIR KEVIN CADLE	207.36	SUPER PAY'T	20/01/92
PROW L	164.88	SUPER PAY'T	15/08/90
PUGLIA R L	258.68	SUPER PAY'T	28/03/91
QUEK AMY	199.67	SUPER PAY'T	26/02/93
RALPH SHELDON SCOTT	173.56	SUPER PAY'T	03/05/93
RAM RADHA NALINI	143.05	SUPER PAY'T	18/01/94
RANGINUI SONIA	185.42	SUPER PAY'T	26/11/93
RAO MADIRAJU SREEDMARA	360.32	SUPER PAY'T	27/09/93
RAPP JASON PIERRE	130.10	SUPER PAY'T	20/09/91
RAWLES R M	401.52	SUPER PAY'T	06/05/91
RAWLING KATHLEEN LYNETT	411.28	SUPER PAY'T	01/05/91
RAY BROOKS PTY LTD	127.75	SUPER PAY'T	26/11/93
READ YVETTE LOUISE	237.79	SUPER PAY'T	25/02/91
REARDON MICHAEL	246.04	SUPER PAY'T	01/10/93
REDDIE LESLIE	105.65	SUPER PAY'T	06/04/93
REES STUART	162.75	SUPER PAY'T	19/02/90
REILLY JOHN	776.00	SUPER PAY'T	21/08/92
REMAC EAGLE	123.60	SUPER PAY'T	31/08/92

BUSINESS FINANCIAL SERVICES—continued

1/33 SARONA ST DANDENONG 3175			
2 BARTLEY STREET NTH AUCKLAND NZ			
575 RAE STREET NORTH FITZROY VIC 3068			
271 ALBERT STREET BRUNSWICK 3056			
26 HILLCREST RD GLENROY 3046			
30 MARSHALL STREET FLEMINGTON 3031			
16 CURACOA DRIVE HASTINGS 3195			
21 PUTT GROVE KBYBOROUGH VIC 3173			
905/500 FLINDERS ST MELBOURNE 3000			
18 CORELLA AVENUE MELTON VIC 3337			
1 ROSE ST BRAYBROOK 3019			
2/80 ROCKBANK ROAD ARDBER 3023			
13 INGLIS RD BERRICK 3806			
15 PASCOE ST WEST MEADOWS 3049			
9 GINIFER AVE NTH ALTONA 3025			
6/94 BEACH RD MENTONE VIC 3194			
166 TEMPLETON STREET WANGARAITA VIC 3677			
15/1 WREXHAM RD PRAHAN VIC 3181			
10/31 OXLEY AVE JANNALI NSW 2226			
7/36 PHILIPSON ST ALBERT PARK 3206			
11/54 BELLEVUE RD BELLEVUE HILL NSW 2023			
17 JANET ST EAST KEILOR 3033			
15 LINA CRB STREET WATSONIA 3087			
PO BOX 14 BAROOGA NSW 2644			
24 WAABIB ST WATERFALL NSW 2233			
7/50 MORANG RD HAWTHORN VIC 3122			
41B OLD LILYDALE RD EAST RINGWOOD VIC 3135			
1 HANSEN RD KILSYTH 3137			
50 MANDOWIE ROAD GLEN WAYERLEY 3150			
12 CHURCHILL ST MONT ALBERT 3127			

Unclaimed Moneys Act 1962

Name of Owner on Books and Last Known Address	Total Amount Due to Unclaimed Owner \$	Description of Unclaimed Money	Date when Amount first became Payable
REN MR F	226.81	SUPER PAY'T	08/03/90
RENZELLA VINCENZO	102.97	SUPER PAY'T	30/07/90
REWUK MELANIE	129.80	SUPER PAY'T	06/11/92
RHOBDA TRACBY	136.97	SUPER PAY'T	15/11/90
RICHARDS MICHAEL	174.51	SUPER PAY'T	27/09/93
RICHARDSON B	168.45	SUPER PAY'T	8/12/90
RICHARDSON JUDITH	248.56	SUPER PAY'T	26/11/93
RIEM KING	132.50	SUPER PAY'T	13/01/94
RIGA MARCO	252.50	SUPER PAY'T	11/09/91
RIGBY LEBLA	377.81	SUPER PAY'T	19/11/90
RIVERS MR J	136.97	SUPER PAY'T	18/12/90
ROACH BRYAN	254.87	SUPER PAY'T	27/09/93
ROBB STEVEN	104.25	SUPER PAY'T	17/05/93
ROBBIN PHILLIP P	109.26	SUPER PAY'T	10/10/90
ROBERTSON LEANNE	118.61	SUPER PAY'T	04/01/91
ROBERTS RICHARD J	331.68	SUPER PAY'T	19/02/91
ROBSON RAYMOND JOHN	1,218.67	SUPER PAY'T	05/08/92
ROCHE GERALD	128.86	SUPER PAY'T	19/05/89
ROGERS CHARMARINE	148.69	SUPER PAY'T	07/05/91
ROGERS GRAHAM LESLIE	289.90	SUPER PAY'T	25/10/91
ROGERS J C	161.09	SUPER PAY'T	18/09/92
ROGERS NICHOLAS	103.18	SUPER PAY'T	12/02/90
ROLLINGS ROMANA	157.57	SUPER PAY'T	30/03/92
ROMSAY CHRISTENE	152.63	SUPER PAY'T	16/09/93
ROSLYN JANICE	120.20	SUPER PAY'T	13/08/92
ROWE JENNIFER	105.95	SUPER PAY'T	27/04/92
ROWLEY JAMES R	181.13	SUPER PAY'T	29/11/93
RUMENS LEIGH TERENCE	347.03	SUPER PAY'T	07/07/93
RUSSELL PAUL	283.05	SUPER PAY'T	06/03/91
SALE MAFI	154.68	SUPER PAY'T	28/02/92

BUSINESS FINANCIAL SERVICES—continued

7/20 CROMWELL RD STH YARRA 3141			
C/O ELPIN CONT'L KNITWEAR P O BOX 522 BOX HILL			
11 RUTLAND CRT KEYSBOROUGH 3173			
7 LOCKE ST BRIGHTON EAST 3187			
1/10 ACBLINGA PLACE MOOLOOCABA QLD 4556			
9/55 ALEXANDER RD EAST ST KILDA 3183			
12 EDGAR ST GLEN IRIS VIC 3146			
18 BELFORT ST DANDENONG VIC 3175			
12 HOULIHAN WAY PAKENHAM 3810			
88 SYCAMORE STREET SOUTH CAULFIELD 3162			
SHAWLANDS CARVAN PARK STH GIPPSLAND HWY 3175			
46/147 TALAVERA RD MANSFIELD NSW 2122			
63 TYLER STREET PRESTON VIC 3072			
20 LEICHHARDT AVE INGLE FARM SA 5098			
3/104 DAVID STREET DANDENONG 3152			
52 KERR ST FITZROY VIC 3065			
5A CONNAUGHTON STREET KEWDALB WA 6105			
LINTON GRANGE DARREN 3754			
147 PRINCES HIGHWAY WERRIBEE 3030			
31 BRAY AVE SEMOPHORE PARK S A 5019			
P O BOX 742 LAKES ENTRANCE 3992			
C/ COPYTONE P/L 635 NICHOLSON ST NTH CARLTON			
18 SUMMIT HILL PARK DR MOOROOLBARK 3138			
10 DARSON CRT TARCOOLA BEACH GERALDTON 6530			
75B/7 CRANE ROAD CASTLEHILL 2154			
193 DORKING ROAD BOX HILL NORTH 3129			
19 OSWALD ST DANDENONG VIC 3175			
26 BOND STY DONNYBROOK W A6239			
50 FORDHAM ST WAVELL HEIGHTS QLD 4012			
428 PLENTY ROAD PRESTON 3072			

Unclaimed Moneys Act 1962

Name of Owner on Books and Last Known Address	Total Amount Due to Unclaimed Owner Money	Description of Unclaimed Money	Date when Amount first became Payable
BUSINESS FINANCIAL SERVICES—continued			
SALTER GARY FREDERICK	217.40	SUPER PAY'T	09/11/90
SAMSON KEVIN	256.25	SUPER PAY'T	28/08/91
SAMUEL SUSAN	195.71	SUPER PAY'T	23/03/93
SANTOS MAROVIC	369.39	SUPER PAY'T	16/02/89
SARGON C	126.17	SUPER PAY'T	17/09/90
SATHAVAN AMBALAWARNER	124.32	SUPER PAY'T	30/11/91
SAYER HEATH CAMERON	122.34	SUPER PAY'T	18/01/94
SCALISE ALLEN DAVID	101.32	SUPER PAY'T	19/03/93
SCARFF JOHN MATHEW	419.95	SUPER PAY'T	17/09/91
SCHMIDT ROBERT WESLEY	188.65	SUPER PAY'T	19/10/93
SCHUBEL IAN	151.83	SUPER PAY'T	30/01/92
SCHUMAKER ROBERT	339.09	SUPER PAY'T	27/09/93
SCHWERDFERGER MICHELLE	152.83	SUPER PAY'T	23/01/89
SCOTT JENNIFER	153.90	SUPER PAY'T	03/05/93
SCOTT MICHAEL	1,197.82	SUPER PAY'T	09/07/93
SEARLE MURRAY JAMES	189.72	SUPER PAY'T	24/10/91
SHOUD RUSONNE	127.84	SUPER PAY'T	20/07/92
SETO JULIE	169.14	SUPER PAY'T	08/01/91
SEVIOR MARY J	131.07	SUPER PAY'T	03/11/93
SHANAHAN PETER G	1,019.95	SUPER PAY'T	26/05/92
SHANKAR JOHN A	167.40	SUPER PAY'T	24/01/90
SHANNON PETER ROBERT	113.57	SUPER PAY'T	15/06/90
SHARNDHIL SARENDEA	251.43	SUPER PAY'T	06/04/92
SHARP L N	137.41	SUPER PAY'T	14/05/91
SHEN PEI JUAN	365.29	SUPER PAY'T	04/11/93
SIDAOUJ CAROLINE	110.20	SUPER PAY'T	28/01/92
SIMI MARK	344.86	SUPER PAY'T	16/03/93
SIMMONS SCOTT LAWRENCE	219.41	SUPER PAY'T	06/03/92
SINCLAIR-JONES PAM	165.39	SUPER PAY'T	20/07/90
SINGH BOB S W	215.64	SUPER PAY'T	15/06/90
581 ESSEX PARK DR ENDEAVOUR HILLS 3802			
92 WAKELY STREET WANTIRNA STH VIC 3152			
25 DUDLEY ST LINDCOMBE NSW 2141			
2/1 MEREDITH ST ELWOOD 3184			
2/100 HAROLD RD STH SPRINGVALE 3171			
9/18 SILVERDALE RD EAGLEMONT VIC 3079			
15 WEBSTER ST NEDLANDS WA 6009			
120 MITCHELLS LANE SUNBURY 3429			
1 HENDERSON ST ARARAT VIC 3377			
510 FRANKSTON FLINDERS ROAD TYABB 3913			
203A RAINBOW STRANDWICK NSW 2031			
172 MURRAY RD PRESTON VIC 3072			
73 STEVENS RD VERMONT STH VIC 3133			
60 HUMB AVE MELTON STH VIC 3338			
P O BOX 13 CHRISTIES BEACH SA 5765			
11 DARLING STREET STH YARRA 3141			
6/57 MAJOR ROAD FAWKNER 3060			
PO BOX 9 LEONORA WA 6438			
3/17 VICTORIA ST WAHGUINYAH 3687			
10 TURNER RD HIGHETT 3190			
150 CHURCH ST RICHMOND VIC 3121			
8/51 WIGRAM STREET HARRIS PARK NSW 2150			
1/26 FERNSIDE AVE BRIAR HILL 3088			
13/6 REDAN ST ST KILDA VIC 3182			
1/20 INVERMAN STREET RESERVOIR 3073			
C/- PMB GERALDTON WA 6530			
3 BARRY ST STH YARRA 3141			
4/22 WONCONA PDE EAST OATLEY 2223			
78 RIVER ST SOUTH YARRA VIC 3141			

Unclaimed Money Act 1962

Name of Owner on Books and Last Known Address	Total Amount Due to Owner	Description of Unclaimed Money	Date when first became payable
BUSINESS FINANCIAL SERVICES—continued			
SINGH GILL GURDEN	195.34	SUPER PAY'T	20/02/91
SINGH RANJIT	173.00	SUPER PAY'T	06/09/93
SKENDER P	135.53	SUPER PAY'T	24/11/93
SKERRI TIMOTHY ROBERT	150.76	SUPER PAY'T	27/05/93
SKONIS MICHAEL	582.14	SUPER PAY'T	26/11/93
SLADB, J S	228.51	SUPER PAY'T	05/07/91
SLATER JULIE	166.97	SUPER PAY'T	19/09/89
SLATTERY ROBERT	211.48	SUPER PAY'T	06/05/92
SLOANIM JUDITH	333.97	SUPER PAY'T	18/01/94
SMART BRENT	213.12	SUPER PAY'T	09/04/92
SMITH BRONWEN C	127.08	SUPER PAY'T	31/07/92
SMITH JODIE ANN	1,246.62	SUPER PAY'T	10/08/93
SMITH LINDSAY	172.61	SUPER PAY'T	26/08/93
SMITH ROBERT WALTER	248.64	SUPER PAY'T	18/01/94
SMITH SHARON	208.22	SUPER PAY'T	16/03/92
SMITH WARREN ASHLEY ADRIAN	106.00	SUPER PAY'T	11/01/94
SNEESBY BRUCE	184.94	SUPER PAY'T	07/11/90
SNOW MICHAEL	186.19	SUPER PAY'T	15/10/92
SOLOMAN BARRY	187.18	SUPER PAY'T	26/07/93
SONG JIAN QUN	332.44	SUPER PAY'T	15/07/93
SOUTHWICK D K	110.92	SUPER PAY'T	27/05/91
SPARKES D W	211.11	SUPER PAY'T	31/07/91
SPICER P J	115.14	SUPER PAY'T	7/09/92
SPOSATO MAURIZIO	127.77	SUPER PAY'T	18/01/94
STAMATOPOULOS L	573.95	SUPER PAY'T	18/04/91
STANLEY CHRISTOPHER	211.05	SUPER PAY'T	18/01/94
STANLEY GRAEME	437.49	SUPER PAY'T	19/07/93
STAPLES T	104.62	SUPER PAY'T	01/03/91
STARK, RAYMOND SHANE	107.11	SUPER PAY'T	02/03/93
STEAD GLENN	161.44	SUPER PAY'T	18/01/94
2 MARONG CRT BORONIA 3155			
24 KIDMAN STREET YARRAVILLE VIC 3103			
Laurie St Mt Magnet WA 6638			
626 Glenferrie Rd Hawthorn VIC 3122			
11/18 Carnoustie Cres Marrara NT 0812			
33 Wells Road Chelsea Heights 3196			
Cherry Lane, 90 Maribyrnong St Footscray 3011			
4 Mc Parlane Rd Mooroopna 3629			
56 Howitt Rd Caulfield VIC 3162			
56 Pembroke Road Kilsyth 3177			
134 Clydeb Street Cranville			
22 Bower Cres Port Adelaide SA 5015			
Main Rd St Albans VIC 3021			
6 Conway Ckt Wodonga VIC 3690			
49 Darebin Drive Thomastown 3074			
254 Beach Rd Black Rock VIC 3193			
C/O Chris Garneau Riverside Quay			
499 Station Street Carlton North 3054			
98/562 Burwood Hwy Vermont VIC 3133			
9/34 Whitehall Street Footscray VIC 3011			
46 Lindrum Rd Frankston 3199 VIC			
6 Grant Crescent Ringwood 3134			
413 Stephenson Rd Mt Waverley 3149			
18 The Boulevard Nth Balwyn VIC 3104			
5 Woodlands St West Doncaster 3108			
Wombat Ridge Killlearn Rd Launching Place VIC			
125 Steven Ave North Altona VIC 3025			
17 Palmer Avenue Balwyn 3103			
10 Crown Street Flemington VIC 3031			
6/22 Cleopatra St Palmyra WA 6157			

Unclaimed Moneys Act 1962

Register of Unclaimed Moneys held by the—

Name of Owner on Books and Last Known Address

Name of Owner on Books and Last Known Address	Total Amount Due to Owner, Money	Description of Unclaimed Money	Date when Amount first became Payable
BUSINESS FINANCIAL SERVICES—continued			
STEPHEN PETER WILLIAM	100.80	SUPER PAY'T	11/09/90
STEPHENS TED G	124.06	SUPER PAY'T	03/04/90
STEPHENSON DAVID	350.72	SUPER PAY'T	24/04/92
STEVEN R	165.41	SUPER PAY'T	29/04/91
STEWART BRADLEY ROBERT	1,482.67	SUPER PAY'T	22/10/92
STONE CRAIG	102.59	SUPER PAY'T	19/03/92
STONE MICHAEL	118.18	SUPER PAY'T	27/12/91
STONE WARREN	545.36	SUPER PAY'T	18/01/94
STONEHAM S G	226.82	SUPER PAY'T	14/06/91
STUART A	112.20	SUPER PAY'T	14/01/91
STUBBS LAURENCE	289.28	SUPER PAY'T	18/01/94
SULLIVAN JASON WILLIAM	167.72	SUPER PAY'T	23/11/92
SUMMERFIELD C P	188.94	SUPER PAY'T	04/12/92
SWETNAM M G	143.11	SUPER PAY'T	25/09/90
SZUKUVA-ORDEGA MIRA	383.87	SUPER PAY'T	28/06/91
TANG VAN UT	170.23	SUPER PAY'T	07/12/93
TANG WILLIAM	483.02	SUPER PAY'T	15/11/89
TARANITO JI SNR	171.36	SUPER PAY'T	02/10/91
TAWA SHI MIN NIMA	115.31	SUPER PAY'T	25/10/91
TAY DE QING	110.16	SUPER PAY'T	29/06/92
TAYLES LARRISSA	239.82	SUPER PAY'T	18/01/94
TAYLOR BAYDEN	112.95	SUPER PAY'T	30/10/91
TAYLOR CARMEL A	235.66	SUPER PAY'T	27/08/92
TAYLOR DEBBIE LEE	117.96	SUPER PAY'T	20/10/93
TAYLOR EMMA VALENTINE	765.27	SUPER PAY'T	11/06/93
TAYLOR MICHAEL ROSS	123.90	SUPER PAY'T	31/12/92
TAYLOR PAUL	175.38	SUPER PAY'T	01/09/93
TAYLOR RICHARD	453.98	SUPER PAY'T	28/11/90
TEMPIEST ERIN	449.98	SUPER PAY'T	23/04/93
TEMPLER PAUL			
366 COMO PDE WEST PARKDALE 3194			
48 WEBCONNA PARADE WEINDOURIE VIC 3335			
47 MERCURY CRESCENT NEWCOMB 3219			
72 FULTON ST CLAYTON 3168			
45 KURROWAH CRESCENT MARGATE QLD 4020			
16 PLEASANT STREET CASTLEMAINE 3450			
2/10 STAWELL STREET CRANBOURNE 3977			
LODERS RD MOOROODUC VIC 3933			
3/44 BEAUMARIS PDE HIGHTT 3190			
15 WARDONG ROAD BALGA WA 6061			
45 SAYER ST MIDLAND WA 6056			
8/866 PASCE RD GLENROY 3046			
3 ARNOTT ST GHEELONG WEST VIC 3220			
176 CENTRE DANDENONG RD CHELTENHAM			
9/21 HELM ST HAWTHORN 3122			
1 RALING VRES SPRINGVALE 3171			
C/- 51-53 PARK ST STH MELBOURNE VIC 3205			
133 BRADY RD EAST BENTLEIGH 3165			
23 KOORYONG ROAD ARMADALE 3143			
7 TRELETHIC ROAD SPRINGVALE 3171			
13/419 MILITARY RD MOSMAN 2088			
5 FRANCIS ST COBURG VIC 3058			
48 MIRRABOOKA ROAD ASHGROVE QLD 4060			
14 WOORILLA CRT FRANKSTON 3199			
2/29 PARK ST STH YARRA VIC 3141			
36B MAYFLOWER CRES CRAIGIE WA 6025			
230 VICTORIA ROAD GLADESVILLE NSW 2111			
60 BRUNSWICK ST KILBURN SA 5084			
8 QUEEN ST BLACKBURN 3130			
6 GOYARRA STREET RYE VIC 3939			

Unclaimed Moneys Act 1962

Register of Unclaimed Moneys held by the—

Name of Owner on Books and Last Known Address	Total Amount Due to Owner	Description of Unclaimed Money	Date when Amount first became Payable
BUSINESS FINANCIAL SERVICES—continued			
THOMAS GJ	103.08	SUPER PAY'T	19/10/93
THOMPSON K A	125.16	SUPER PAY'T	05/02/91
THOMPSON S M	111.26	SUPER PAY'T	24/10/90
THORN R C	227.27	SUPER PAY'T	23/03/92
TIAN JIM	166.53	SUPER PAY'T	25/05/93
TILTON ANTHONY ROBERT	165.02	SUPER PAY'T	27/12/91
TITLEY ANTHONY	344.29	SUPER PAY'T	09/09/92
TODARO JOHN	772.00	SUPER PAY'T	30/07/90
TODD ALAN WILLIAM	203.39	SUPER PAY'T	20/12/91
TOMASKOVIC PETER	228.76	SUPER PAY'T	30/07/90
TOMIZAKI F	234.58	SUPER PAY'T	04/04/91
TOMKINSON CRAIG	102.21	SUPER PAY'T	30/11/91
TONKS STEVEN MARK	233.12	SUPER PAY'T	13/01/94
TOTH ANDREW	251.51	SUPER PAY'T	08/06/93
TRAYNOR DAVID	1,520.27	SUPER PAY'T	17/05/93
TROBBIANI FRANK	229.60	SUPER PAY'T	04/05/90
TRUONG BA LANH	182.88	SUPER PAY'T	24/05/93
TSATOUMAS JENNY	142.16	SUPER PAY'T	12/05/92
TU YONG M	116.34	SUPER PAY'T	21/01/92
TUCKER SAM	111.59	SUPER PAY'T	09/05/91
TURLEY ROSEMARY	115.58	SUPER PAY'T	13/12/90
TURNER ANGELIQUE	148.34	SUPER PAY'T	26/10/93
TURNER GLEN RAYMOND	253.93	SUPER PAY'T	15/10/92
ULAS BEXIR	174.60	SUPER PAY'T	20/01/92
UNDERWOOD JAMIE ROLD CLIFFORD	171.25	SUPER PAY'T	19/08/93
USKI PETER	123.57	SUPER PAY'T	06/04/93
VAN L N	190.11	SUPER PAY'T	13/07/93
VANCE FIONA AMY RUTH	451.18	SUPER PAY'T	26/10/90
	224.64	SUPER PAY'T	07/12/90
	419.03	SUPER PAY'T	09/10/90

Name of Owner on Books and Last Known Address

BUSINESS FINANCIAL SERVICES—continued

4 O'CONNOR WAY KALGOORLIE WA 6430			
18 CHURINGA DVE CHURCHILL 3642			
9/62 HAROLD ST MIDDLE PARK 3088			
RMB 4384 NUMURKAH 3636			
1/27 ELDRIDGE STREET FOOTSCRAY VIC 3011			
22 CANTERBURY STREET OAKLEIGH 3166			
300 WARRIGAL RD CHELTENAM 3192			
C/O ELFIN CONT'L KNITWEAR P O BOX 522 BOX HILL			
"WINDARRAH" DAVY STREET TARADALE 3447			
C/O ELFIN CONT'L KNITWEAR P O BOX 522 BOX HILL			
2/1A VIEW ST SPRINGVALE 3171			
C/O LENNOX MANAGEMENT P O BOX 46 MENTONE 3194			
8 BANKSIA RD CARINGBAH NSW 2229			
UNIT 1/8 NORMAN ST FREMANTLE WA 6160			
10 WARRAGAMBA CRT KEYSBOROUGH VIC 3173			
141 MARINDAL DR ROWVILLE 3178			
1/770 MALVERN RD ARMADALE VIC 3143			
QUARRY ROAD COLERAIN 3315			
5/33 WAIORA PARADE WEST FOOTSCRAY 3012			
5/139 GLEINHUNTLY ROAD HLWOOD 3184			
237 VICTORIA ST ABBOTSFORD 3121			
185 FT LONSDALE RD FT LONSDALE VIC 3225			
177 NICHOLSON PDB CRONOILLA 2230			
32/77 QUEENS RD VIC 3004			
RMB 9324 WANGARATTA VIC 3678			
121 LOWER DANDENONG RD MENTONE VIC 3194			
2-4 MASAN DVE BRAESIDE VIC 3195			
82 LIVERPOOL RD CLAYFIELD QLD 4011			
189 BRUNSWICK ST FITZROY 3065			
196 CANNING ST CARLTON 3053			

Unclaimed Moneys Act 1962

Register of Unclaimed Moneys held by the—

Name of Owner on Books and Last Known Address	Total Amount Due to Owner	Description of Unclaimed Money	Date when Amount first became Payable
BUSINESS FINANCIAL SERVICES—continued			
VANZYL MR H	256.39	SUPER PAY'T	21/06/88
VAUGHAN GERALDINE	103.91	SUPER PAY'T	10/04/91
VILLA HAYDON TROY	187.00	SUPER PAY'T	04/11/93
VERINA JAYNE QUAID	104.90	SUPER PAY'T	10/11/93
VERSCHOOR CYNTHIA	2,500.00	SUPER PAY'T	18/01/94
VICTORIAN PROFESSIONAL GRP MANGMNT	181.90	SUPER PAY'T	29/05/90
VILLANVENA ROEDAM	168.98	SUPER PAY'T	17/09/92
VITACCA MICHAEL	248.76	SUPER PAY'T	22/05/89
VIZE TERRY	225.93	SUPER PAY'T	19/05/92
VORGA RONALD	127.15	SUPER PAY'T	15/04/92
VUONG THI HONG THAM	193.86	SUPER PAY'T	21/02/92
WAIN MATTHEW	141.72	SUPER PAY'T	26/03/91
WALE WILLIAM	120.93	SUPER PAY'T	08/10/93
WALKER MICHAEL	217.18	SUPER PAY'T	28/01/93
WALLACE DAVID	241.19	SUPER PAY'T	25/01/93
WALLACE JOSEPHINE WENDY	108.41	SUPER PAY'T	01/12/93
WALLBANK JANICE PATRICIA	657.57	SUPER PAY'T	18/01/94
WANG HONG	236.32	SUPER PAY'T	13/07/90
WARN SONJA	216.30	SUPER PAY'T	08/04/91
WATSON CLIVE RODERICK	175.19	SUPER PAY'T	12/04/90
WATSON SAMUEL	108.33	SUPER PAY'T	06/09/93
WEBBER ANNITA	662.54	SUPER PAY'T	09/10/92
WEBBS GAVIN J	153.81	SUPER PAY'T	07/05/90
WEGMULLER KATHREN, MARY	267.73	SUPER PAY'T	11/02/92
WEIR B	254.49	SUPER PAY'T	29/11/93
WEIR ROBINA MAREE	127.51	SUPER PAY'T	08/10/93
WELDMAN MICHAEL PATRICK	203.53	SUPER PAY'T	04/03/91
WEST DAVID GRAHAM	167.86	SUPER PAY'T	17/01/91
WEST HELEN	107.37	SUPER PAY'T	21/10/92
WHITE JON	137.12	SUPER PAY'T	27/09/93

Unclaimed Moneys Act 1962

Name of Owner on Books and Last Known Address	Total Amount Due to Unclaimed Owner Money	Description of Unclaimed Money	Date when Amount first became Payable
WHITLOCK DALE	174.53	SUPER PAY'T	12/11/92
WHITTING RODNEY	120.68	SUPER PAY'T	04/07/91
WHYTE STEVEN	142.86	SUPER PAY'T	27/09/93
WILLETTON GERARD	105.52	SUPER PAY'T	11/12/92
WICKERS BARRY	137.45	SUPER PAY'T	20/01/93
WIE MR DAVID JAMES	196.76	SUPER PAY'T	28/09/93
WIENAND GRAHAM ANTHONY	353.73	SUPER PAY'T	28/09/93
WILKINS BEVERLEY ANNE	118.88	SUPER PAY'T	14/02/92
WILCOX MARY T	101.69	SUPER PAY'T	25/05/92
WILLIAM P	193.00	SUPER PAY'T	23/10/90
WILLIAMS FIONA MARBE	105.85	SUPER PAY'T	27/09/93
WILLIAMS LYNETTE	229.47	SUPER PAY'T	28/02/90
WILLIAMSON SUSAN ELIZABETH	107.62	SUPER PAY'T	23/01/91
WILSON ANTHONY FRANCIS	248.22	SUPER PAY'T	18/01/94
WILSON DAVID WILLIAM	148.20	SUPER PAY'T	18/01/94
WILSON KATHERINE	153.89	SUPER PAY'T	01/08/91
WILSON NICOLE MICHELLE	129.88	SUPER PAY'T	26/03/92
WILSON ROBERT	188.95	SUPER PAY'T	20/05/91
WILSON STEWART P	373.89	SUPER PAY'T	18/01/94
WINNMAR K R	151.81	SUPER PAY'T	25/09/90
WITTMER JOHN ANTHONY	452.01	SUPER PAY'T	21/09/93
WONG A	619.57	SUPER PAY'T	23/05/91
WONG T S	148.39	SUPER PAY'T	24/04/91
WOOD IAN KHITH	235.69	SUPER PAY'T	28/07/93
WOODGATE LEIGH	178.62	SUPER PAY'T	31/05/90
WOOTLIFF MICHELLE	323.69	SUPER PAY'T	04/11/93
WRIGHT A M	498.47	SUPER PAY'T	14/01/91
WRIGHT GRAEME H	116.59	SUPER PAY'T	10/08/87
XI MR NELSON	257.77	SUPER PAY'T	21/10/92
XU Y	168.77	SUPER PAY'T	30/08/90

BUSINESS FINANCIAL SERVICES—continued

C/O P O 130 HIGH ST CRANBOURNE 3977			
9 BARINA AVE MOOROOLBARK 3138			
27 RAMSAY ST SOUTH COROWA NSW 2646			
LKA-1ST AGNES COURT GLENROY 3046			
16 WRIGHT STREET MOUNT EVELYN 3796			
226 CANTERBURY RD ST KILDA VIC 3182			
7949 PUNT RD STH YARRA VIC 3141			
75 PARK ROAD CHELTENHAM 3192			
136 FYFFE STREET THORNBURY 3071			
5/1419 HIGH ST GLEN IRIS 3146			
445 GORDON RD MT WAVERLEY VIC 3149			
4/283 DORSET RD BORONIA 3155			
FLAT 16 17 WISEWOOD AVE SEAFORD 3198			
316 ALBERT ST SEBASTAPOL VIC 3550			
771 GREAT NORTHERN HWY MIDLAND WA 6056			
3/4 PARKVIEW ROAD FAIRLIGHT NSW 2094			
12 THE WALLABY RUN CHIRNSIDE PARK 3116			
8/190 MURRUMBEENA RD MURRUMBEENA 3163			
C/- 204 CHARLES ST NORTH PERTH WA 6006			
BOX 370 ECHUCA 3465			
2 CEPHALOTUS RD WALLISTON WA 6076			
1/40 PACIFIC PARADE DEE WHY NSW 2099			
ADDRESS UNKNOWN MEMBER IN MALAYSIA			
4/19 BIRDWOOD AVE LANE COVE NSW 2066			
16/89 COLLINS ST MENTONE 3194			
21 ASTER ST WILLETTON WA 6148			
77 BOURKE ST LEEDERVILLE WA 6007			
7 FERGUSON ST UPWEY VIC 3158			
29 HOPE ST SPOTSWOOD VIC 3015			
24 EDMOND ST SPRINGVALE 3171			

Unclaimed Moneys Act 1962

Register of Unclaimed Moneys held by the—

Name of Owner on Books and Last Known Address	Total Amount Due to Owner Money	Description of Unclaimed Money	Date when Amount first became Payable
BUSINESS FINANCIAL SERVICES—continued			
YARROW CRAIG JOHN	252.29	SUPER PAY'T	05/11/93
YEE KOK PEN	167.35	SUPER PAY'T	28/06/91
YEE WANG SANG	129.03	SUPER PAY'T	21/06/90
YIN LIJIE	416.26	SUPER PAY'T	24/01/90
YNSUA KARINA ETHEL	132.76	SUPER PAY'T	26/05/93
YOLDEN NATHAN MARK	216.52	SUPER PAY'T	31/07/90
YORKE KOHAN	187.50	SUPER PAY'T	22/10/91
YOUNG GRAHAM	176.57	SUPER PAY'T	13/03/92
YOUNG GREGORY JOHN	195.97	SUPER PAY'T	25/05/93
YOUNG MA	116.75	SUPER PAY'T	27/06/90
YOUNG STEVEN	142.30	SUPER PAY'T	27/12/91
YUNG HENRY	179.89	SUPER PAY'T	20/02/91
ZANKER BRIAN	149.60	SUPER PAY'T	28/02/90
ZECVIC DRAGICA	164.52	SUPER PAY'T	29/05/91
ZHANG JIE	100.74	SUPER PAY'T	31/07/91
ZHAO TONY TING	223.97	SUPER PAY'T	08/05/90
ZHAO YUN HUI	158.30	SUPER PAY'T	05/12/91
ZHENG QUI WEN	180.72	SUPER PAY'T	14/01/94
ZHENG WE GEN	193.82	SUPER PAY'T	12/06/91
ZHOU LISA	365.25	SUPER PAY'T	18/12/92
ZHOU RICHARD	249.66	SUPER PAY'T	23/05/91
ZHOU YUB YUE	251.59	SUPER PAY'T	22/04/92
ZHU TIAN CHURY	155.87	SUPER PAY'T	30/11/90
ZUN JULIB MARGARET	919.89	SUPER PAY'T	22/06/93
26 IRIS ST GAILLES QLD 4300			
5 WILLESDEN RD OAKLEIGH 3166			
24 BURLINGTON ST OAKLEIGH 3166			
1/242 ALMA ROAD ST KILDA 3182			
9 ROMAN CRT HAMPTON PARK VIC 3976			
14 YARRA STRBET SOUTH YARRA 3141			
14 LEONARD CRES BUNDOORA 3083			
51 HAYDOWN ROAD ELIZABETH GROVE SA 5113			
6 MINIAH CRT DINGLEY VIC 3172			
146/22 RUPERT ST WEST FOOTSCRAY 3012			
24 RUYTON DRIVE WEST ROSEBRUD 3940			
1/14 ALEXANDER ST BOX HILL 3128			
50 HERBERT ST NORTHCOTE 3070			
1/40 EAST ESPLANADE ST ALBANS 3021			
1/7 MILLER STRBET PRAHRAN 3181			
7/15 TOORONGA RD MALVERN 3144			
2/68 DECARLE STREET BRUNSWICK 3056			
2/46 BEVAN AVE CLAYTON STH VIC 3169			
8/76 BAKTON ST RESERVOIR 3073			
1/90 STATION RD AUBURN NSW 2144			
1/84 BEACH ROAD FRANKSTON 3199			
2/26 LILLIMUR RD ORMOND 3204			
1/64 CAKWELL STREET MALVERN 3144			
54 YUILLE STRBET FRANKSTON VIC 3199			

Unclaimed Moneys Act 1962

Register of Unclaimed Moneys held by the—

Name of Owner on Books and Last Known Address	Total Amount Due to Owner	Description of Unclaimed Money	Date when Amount first became Payable
\$			
BONLAC FOODS LTD			
Barber, R and L, North Geelong	1360.64	Cheque	1994
G McLaren Auto Elect, Warrnambool	399.35	"	"
Colac Mid City Motel, Colac	119.60	"	"
Minderbinder Publish, Mordialloc	1180.00	"	"
Stewart, M L, Shepparton	436.05	"	"
Stevens, A, Boolarra	208.00	"	"
Convey, P L and A M, Warrnambool	195.00	"	1993
Diprose, M N and C M, Congupna	187.00	"	"
Ford, M A, Tallygaroopna	2843.95	"	"
Kaye Levy & Co, Caulfield South	300.00	"	"
Kinsella, Martin	250.00	"	"
McKenzie, R J, Camperdown	155.25	"	"
Kavanagh, R G, Garvoc	487.15	"	"
Proposch Timber Pty Ltd, Drouin	265.90	"	"
Terang Football Club, Terang	200.00	"	"
Urquhart, N	187.93	"	"
Warner, J, Finley	420.30	"	"
Clifton, A T, Lowes Dale, NSW	115.30	"	"
Hammet, A M, Toora	230.60	"	"
Simmons, R E, Narre Warren	864.75	"	"
Sanowara, Red Cow Building, 601 Ramjoy Mahajan	1487.61	"	"
Arbuthnot, J M and G M, Tarwin Lower	200.62	"	"
Tanner, P F and L F, Goorambat	371.27	"	"
Gregory, R B, Girgarre	103.17	"	"
Hadfield, V J, Stanhope	120.82	"	"
c/o T M Curtis Longacres, Graziers Highton	117.25	"	"
Mead, W E, Echuca	216.85	"	"
Meagher, L N, Rushworth	216.85	"	"
Robbins, J M, Rushworth	173.07	"	"
AGSAFE, North Sydney, NSW	120.00	"	"
A Purdy & Co Pty Ltd, Warragul	930.00	"	"
Ardmona Football Club, Ardmona	250.00	"	"
Aust Dairy Corp, Glen Iris	300.00	"	"
Brambles Security Serv, North Melbourne	362.64	"	"
Charlie Freight Serv, Kyabram	121.00	"	"
Chiller Freight Express, Altona North	243.28	"	"
Colac A & P Society, Colac	120.00	"	"
Gardiner, H C, Shepparton	398.92	"	"
Beard, N, Mainwood, NSW	173.54	"	"
Briggs, R T, via Rochester	103.82	"	"
Doncon, G S and M, Numurkah	198.72	"	"
Evans, N I, Tatura	159.37	"	"
95169			
CONTACT: LINDSAY PHILLIPS, PHONE 9270 0922			

NATIONAL FORGE LIMITED

O'Moore, Liam J and Elaine M, 3A/5 Pkns Condominium, Persiaran Raja, Muda, 7 Shah Alam, Selangor, Malaysia	119.00	Cheque	30.11.93
95166			
CONTACT: LEONIE POSTLE, PHONE 9288 5533			

Unclaimed Moneys Act 1962

Register of Unclaimed Moneys held by the—

Name of Owner on Books and Last Known Address	Total Amount Due to Owner	Description of Unclaimed Money	Date when Amount first became Payable
\$			
BENDIGO BUILDING SOCIETY			
Schade, W L, PO Box 499, Bendigo	131.86	Dividend	30.4.93
Tacitus Quartus Nominees, 87 Pleasant Rd, East Hawthorn	175.88	Interest	30.11.93
Aust Guarantee Corp	107.00	Cheque	11.12.92
Aust Directory Serv	349.00	"	24.7.93
Aust Directory Serv	349.00	"	24.8.93
Gillott, D M	262.15	"	2.12.92
Ashman, L J	590.33	"	1.12.92
Massie, T E and N C	223.61	"	25.12.92
Sloan, R C, S E and C W	243.45	"	15.3.93
Perez, A P	141.43	"	22.4.93
South, N	1288.83	"	27.10.93
Fraser, G	140.00	"	22.7.93
North West Funerals	1509.00	"	12.3.93
Traffic Camera Office	165.00	"	30.9.93
Dorevitch Pathology	120.60	"	11.6.93
Roy, D	222.00	"	30.7.93
Carrington, G	730.00	"	7.4.93
Doctor Yu	350.00	"	9.8.93
Swann Insurance	877.50	"	30.4.93
Treeve, N G	10377.58	"	16.11.93
Alderson, S	176.96	"	9.6.93
Country Wide Valuers	150.00	"	12.10.93
VSAD	123.25	"	30.9.93
Housing Loans Insurance Corp	145.00	"	25.8.93
Beaven, H E	124.35	"	14.9.93
Lindsay, G J	226.00	"	19.11.93
Luscombe, J H and R K	102.09	"	11.10.93
Dunn, R L	134.46	"	21.10.93
Craig, A S	2000.00	"	21.12.92
Hullich, B	1650.00	"	8.12.93
Rothacker, Charles	346.24	"	12.11.93
Rothacker, Charles	298.99	"	"
Negoro, M	10000.00	"	17.12.93
Insurance & Superannuation Com	200.00	"	5.2.93
AMP Society	311.40	"	21.4.93
AMP Society	302.77	"	"
Collie, D M	233.50	"	28.5.93
Crook, K	4000.00	"	18.6.93
Crook, K	400.00	"	"
Treasure, M	400.00	"	"
Jens-Gaunt	236.00	"	25.6.93
Fortis Life Assurance	148.12	"	22.6.93
Readers Digest	149.85	"	3.9.93
Facts Steering Committee	6965.26	"	23.8.93
Northern Territory Treasury	101.50	"	20.9.93
Borbidge, R T and Ginies, I	150.67	"	29.10.93
Adler, Alan	248.00	"	10.11.93
Pryor, G R	2500.00	"	3.12.93
Aust Taxation Office	216.00	"	5.11.93
Andrew Senia & Ass	150.00	"	10.12.93
World Vision Australia	281.85	"	20.12.93
95163			

CONTACT: DAVID SPENCE, PHONE 9693 9441

Unclaimed Moneys Act 1962

Register of Unclaimed Moneys held by the—

Name of Owner on Books and Last Known Address	Total Amount Due to Owner	Description of Unclaimed Money	Date when Amount first became Payable
\$			
POWERCOR AUSTRALIA LTD			
Botheras, Rodney P, Fl 9, 2 Kirby St, Golden Square	111.07	Credit	8.11.93
Roberts, David, 29 Howard St, Epsom	368.80	"	9.12.93
Cash & Carry Wholesaler, Shop 6, 51 Breen St, Bendigo	221.10	"	6.1.94
Green, Alma M, 36 Eaglehawk Rd, Bendigo	184.20	"	20.1.94
Michel, Kerrie A, 36 Westmoreland Cres, Shepparton	229.75	"	26.10.93
Casham, B G and L D, 10 Bay St, Merrigum	121.45	"	15.11.93
Satter, W, McColl Rd, Girgarre	221.40	"	7.12.93
National Heart Foundation, 49 High St, Shepparton	554.25	"	21.12.93
Rahe, M, 35 Skene St, Shepparton	156.40	"	7.1.94
Wilson, W, 93 Nixon St, Shepparton	150.25	"	21.3.94
Mott, Stephen, 29 Arnott St, Horsham	119.35	"	24.12.93
Assoc Fibres P/L, Playford St, Stawell	321.49	"	5.1.94
Murphy, M, 402 Ligar St, Ballarat	200.05	"	28.2.94
Oupan Resources, Pump Cowans, Bacchus Marsh	773.00	"	1.1.93
Xureb, Cindy, 63 David St, Altona	152.00	"	1.1.94
Currao, Felix, 7 Banksia Cres, Hoppers Crossing	240.00	"	1.3.94
O'Connor, Kevin J, c/o C Clark, 43 Juke St, Warrnambool	162.00	"	6.1.93
3M Australia P/L, PO Box 99, Dymble, NSW	653.76	"	9.2.93
A Noble & Son P/L, PO Box 806, Dandenong	1926.00	"	24.8.93
Aarque Systems P/L, GPO Box 491G, Melbourne	256.68	"	9.3.93
Aarque Systems P/L, GPO Box 491G, Melbourne	147.80	"	4.3.93
ABB Distribution P/L, 376 Newbridge Rd, Liverpool	380.00	"	21.7.93
Abbey Equipment, PO Box 309, Clayton	109.65	"	29.12.92
AG PS, GPO Box 84, Canberra, ACT	128.80	"	15.2.94
AG PS, GPO Box 84, Canberra, ACT	109.68	"	5.4.93
Alsaf Safety Industries Pty Ltd, PO Box 218, Moorabbin	1065.00	"	14.10.93
AMPOL, GPO Box 2861AA, Melbourne	318.48	"	19.7.93
AMPOL, GPO Box 2861AA, Melbourne	230.49	"	9.6.92
Apollo Power Plus Batteries, 4 Market Rd, Sunshine	126.48	"	14.4.93
Australian Challenge (OPS), PO Box 221, Cheltenham	600.00	"	8.10.93
Australian Earthing Electrodes, PO Box 112, Kellyville, NSW	3469.50	"	10.1.94
Cant Team Em, Private Bag 12, West Footscray	295.86	"	16.6.93
Carrum Engineering, 25 Titan Dve, Carrum Downs	1580.00	"	7.12.93
Castrol (Aust) P/L, PO Box 45, Footscray West	258.88	"	19.3.93
Castrol (Aust) P/L, PO Box 45, Footscray West	226.52	"	2.7.93
Coffs Harbour Harwoods P/L, PO Box 296, Coffs Harbour, NSW	3801.00	"	21.5.93
Computer Gate P/L, 25/45 Gilby Rd, Mt Waverley	582.40	"	7.12.93
CSR Humes Ltd, Rosebank Ave, Westall	3808.56	"	8.11.91
CSR Humes Ltd, Rosebank Ave, Westall	5196.88	"	18.12.91
Dant Industries, 612 Smith St, Clifton Hill	424.00	"	3.6.93
Dulmison, 1353 North Rd, Huntingdale	139.00	"	11.2.94
Dunlop Footwear, PO Box 189, Port Melbourne	230.00	"	30.8.93
Elsom Eng, 2/11 Gatwick Rd, Bayswater	706.38	"	30.3.93
Email Meters, PO Box 4, Waterloo, NSW	186.00	"	15.9.93
Email Westinghouse, PO Box 85 Roseberry, NSW	121.85	"	29.11.93
Engineers Euroa, 35 Scott St, Euroa	276.00	"	15.4.93
G. B. Lilley P/L, 19-21 Moncrief Rd, Numawading	290.00	"	20.1.93
G. B. Lilley P/L, 19-21 Moncrief Rd, Numawading	125.20	"	25.10.93
G T Graphics, 34 Stanley St, Collingwood	820.00	"	13.12.93
GenVic, MDC PO Box 195, Morwell	207.60	"	25.2.94
Holec P/L, 5/585 Blackburn Rd, Nottinghill	260.00	"	4.6.93
J Blackwood & Son, PO Box 452, Mt Waverley	585.00	"	18.6.93
J Furphy & Sons P/L, PO Box 1390, Shepparton	6910.00	"	9.9.93
J Furphy & Sons P/L, PO Box 1390, Shepparton	1232.00	"	4.10.93
James Hardie Pipelines	1373.97	"	12.3.93

Unclaimed Moneys Act 1962

Register of Unclaimed Moneys held by the—

Name of Owner on Books and Last Known Address	Total Amount Due to Owner	Description of Unclaimed Money	Date when Amount first became Payable
\$			
POWERCOR AUSTRALIA LTD— <i>continued</i>			
Lawrence & Hanson, 142 Dorcas St, South Melbourne	209.00	Credit	14.1.94
Lober, Max L, 229 Swan St, Richmond	780.00	"	17.6.93
Mobil, PO Box 575, Brisbane, Qld	600.00	"	22.11.93
Montana Timber Holdings, PO Box 266, South Yarra	330.90	"	4.8.93
Morwell Distribution, PO Box 195, Morwell	207.58	"	11.3.94
MSS Records Management, Sarton Rd, Clayton	160.00	"	6.4.93
Polk Printing, 77 Wellington St, Collingwood	105.50	"	13.7.92
Mott, R J and E V, 26 Cheryl Cres, Belmont	436.12	"	8.2.94
Shell, PO Box 1687F, Melbourne	1284.33	"	16.3.93
South Pacific Fasteners, PO Box 6883, Wetherill Park, NSW	197.26	"	19.8.92
Spicers Paper, Private Bag 2, Preston	180.00	"	26.11.93
Telecom Mobile Phones, 488 City Rd, South Melbourne	2148.00	"	25.5.93
Thelmal Bay, 1 Ponting St, Williamstown North	2460.25	"	19.5.93
Warburton, Thomas, 40 Kavanagh St, South Melbourne	211.20	"	22.6.93
Vinidex Tubemakers, PO Box 2432, Mildura	818.80	"	24.5.93
Vinidex Tubemakers, Private Bag Mail 448, Clayton	240.80	"	26.1.93
Weber South Pacific, PO Box 3844, South Brisbane, Qld	280.80	"	29.10.93
Weber South Pacific, PO Box 3844, South Brisbane, Qld	486.00	"	"
Hydro Electricity Commission, 4-16 Elizabeth St, Hobart	440.00	"	15.12.93
Mandon, G, 18 Howell Ave, Surrey Hills	200.00	"	27.10.93
Pebmar P/L, 129 Oglivie Ave, Echuca	221.96	"	15.12.93
95027 — CONTACT: RON CARR, PHONE 9691 5102			
FORD CREDIT AUSTRALIA LIMITED			
Robertson, C M, Lot 44 Thompsons Rd, Lyndhurst	207.40	Overpayment	24.8.93
McClymont, C, 1/43 Hartington St, Kew	127.84	"	8.3.94
Adams Engineering, 5 Vine Crt, Narre Warren	1397.20	"	23.12.91
Albrecht, D, 57 Forest Dve, North Frankston	1115.22	"	"
Ali, H, 41 O'Connor St, Reservoir	317.97	"	"
Ali, Y, 41 O'Connor St, Reservoir	477.67	"	"
Baxter, K, 48 Mitchell St, Kyneton	692.45	"	"
Bowerman, S, 16 Princes Hwy, Pakenham	211.44	"	"
Byron, P, 1/42 Glenhuntly Rd, Elwood	184.18	"	"
Chapman, G, 75 Beatty St, West Ivanhoe	784.23	"	"
Collinson, P, 5 Dunblane St, North Balwyn	223.17	"	"
Davies, D, 14 George St, Beaconsfield	569.43	"	"
Ferguson, G, 6 Horsham Crt, St Albans	496.51	"	"
Fish, L, 1/16 Colburn Way, Caboolture, Qld	566.65	"	24.12.91
Garcia, A, 18 Lyking St, Pascoe vale	324.75	"	23.12.91
Gonzales, C, 57 Linda St, Coburg	282.05	"	"
Heit, E, 57 Drinkwater Cres, Sunshine	190.39	"	24.12.91
Hemmings, W, 10 Holmead Rd, Eight Mile Plains, Qld	1251.40	"	"
Howden, R, 14 Undah Dve, Eltham	718.41	"	23.12.91
Lea-Smith, M, 9/5-13 Percy St, Mitcham	240.45	"	"
Lowry, R, 3/75 Bowmore Rd, Noble Park	780.94	"	"
Lyster, D, 14 Lima Ave, Tyabb	123.69	"	"
Macpherson, G, 51 Wallace St, Beaconsfield	341.18	"	24.12.91
Martin, S, 14 Oak Cres, North Caulfield	350.10	"	23.12.91
Matthews, W, 20 Site Bourke St, Korumburra	569.87	"	"
Mawson, R, S19/473 Station St, Carrum	479.41	"	"
McIntyre, T, 61 Lahinch St, Broadmeadows	157.70	"	"
Nguyen, K, Canterbury St, Flemington	625.34	"	"
O'Dell, D, 34 William St, Dandenong	294.16	Interest	"

Unclaimed Moneys Act 1962

Register of Unclaimed Moneys held by the—

Name of Owner on Books and Last Known Address	Total Amount Due to Owner	Description of Unclaimed Money	Date when Amount first became Payable
\$			
FORD CREDIT AUSTRALIA LIMITED—continued			
O'Shea, G, Redlynch, Cairns, Qld	423.35	Interest	"
O'Sullivan, T, Cardinia Rd, Cardinia	836.87	"	23.12.91
Pa, T, 34 Finch St, East Malvern	363.44	"	24.12.91
Parker, M, 2/1 Marnoo St, Braybrook	167.33	"	"
Scettrine, W, 3/568 Glenferrie Rd, Hawthorn	349.19	"	23.12.91
Stepic, L, 12/69 Kingsville St, West Footscray	575.48	"	"
White, D, 2 Whitehaven St, Wantirna	396.07	"	24.12.91
Williamson, M, 6 The Rialto, Chadstone	876.91	"	23.12.91
Young, M, 24 Macpherson St, Footscray	849.13	"	"
Zelada, R, 3/6 Rondell Ave, West Footscray	221.85	"	"
Theodorou, C, 34 Hubbard Ave, Mulgrave	254.56	"	24.12.91
Little, J, 12A/44 The Avenue, East St Kilda	211.20	"	23.12.91
Benson, T, 200 Elizabeth Dve, Sunbury	287.82	"	24.12.91
Blick, B, 1/79-9 Peel St, Windsor	310.50	"	23.12.91
Decarvalho, M, 41 Gunthur Ave, Springvale	228.83	"	"
Downes, R, 27 Beacon Dve, Langwarrin	418.49	"	"
Pham, B, 3/33 Royal Ave, Springvale	545.31	"	"
Tran, V, 1/33 Browning Ave, Clayton	386.91	"	"
Weerasinghe, Y, 4 Murra Crt, Ashwood	290.92	"	24.12.91
Thomas, G, 11/20 Gladesville Blvd, Patterson Lakes	419.13	"	"
Waldon, W, 27 Seven Oaks Rd, East Burwood	1140.26	"	23.12.91
Bovey, M, 242 Princes Hwy, Narre Warren	212.91	"	"
Meroiti, G, 16/192 Cecil St, South Melbourne	550.47	"	"
Janz, G	778.75	"	"
Stock, P, 21 Pindak St, St Albans	577.15	"	"
Mollasi, I, 146 Weidlich Rd, Eltham	361.89	"	"
McAulay, C, 1/8 Minnie St, Sandringham	135.07	"	"
Sherritt, J, 1A Melaleuca Dve, Clayton	425.22	"	"
Heeney, D, 2/26 Emo St, East Malvern	175.21	"	"
Wu, T, 33 Illawarra Rd, Balwyn	924.26	"	"
Preston, R, 39 Avondale Rd, Preston	886.08	"	"
Lim, C, 10/94 Thames St, Box Hill	952.67	"	"
Bourke, C, 9 Salisbury Gve, Hawthorn	235.15	"	"
Booth, C, 64 Canterbury Rd, Heathmont	276.68	"	"
Burden, R, 14 Rowland St, East Bentleigh	460.42	"	"
Tucker, B, 2/3 Nicholson Cl, Research	436.12	"	"
Jones, T, 6 Highland Ave, North Clayton	466.97	"	"
Duong, V, 6/38 Bishop St, West Footscray	782.62	"	"
Wight, G, 31 Camelot Dve, Glen Waverley	369.12	"	24.12.91
Fraser, J, 15 Valarie St, Pascoe Vale	491.88	"	"
Brand, A, 7/130 Alma Rd, St Kilda	629.09	"	"
Tu, Q, 100/204 Altona St, Kensington	121.33	"	"
Mathews, L, 9 Browning St, Kilsyth	284.42	"	"
Dixon, P, 3 Derby Cres, Carnegie	254.33	"	"
Murray, I, 38 McKinley Ave, Malvern	418.95	"	"
Huynh, H, 2/436 Geelong Rd, West Footscray	185.92	"	"
Lazaridis, I, 9/2 Forrest St, Sunshine	811.99	"	"
Clinch, S G, 126 Rennie St, East Coburg	207.79	"	30.9.93
Robinson Luteria Artistica Pty Ltd, 37 Burnie St, Clovelly, NSW	114.33	"	31.12.92
McCarty, T A, 4/14 Grosvenor St, Neutral Bay, NSW	121.21	"	1.3.93
Mekrungruengkul, S, PO Box 817, Newtown, NSW	127.25	"	30.6.93
Cooke, G G and Monsour, M T, 2 Brighton St, Harbord, NSW	117.77	"	30.9.93
Jeffrey, Andrew M, 7/120 Clovelly Rd, Randwick, NSW	101.06	"	31.3.94

PROCLAMATIONS

ACTS OF PARLIAMENT

Proclamation

I, Richard E. McGarvie, Governor of Victoria declare that I have today assented in Her Majesty's name to the following Bills:

No. 63/1995 Infertility Treatment Act 1995

No. 64/1995 Superannuation Acts (General Amendment) Act 1995

No. 65/1995 Water Industry (Amendment) Act 1995

Given under my hand and the seal of Victoria at Melbourne on 27 June 1995

(Ls.) R. E. MCGARVIE
By His Excellency's Command

JEFF KENNETT
Premier

No. 63/1995 (1) This Part (except section 5) comes into operation on the day on which this Act receives the Royal Assent.

(2) Section 170 is deemed to have come into operation on 1 July 1988.

(3) The remaining provisions of this Act come into operation on a day or days to be proclaimed.

(4) If a provision referred to in sub-section (3) does not come into operation within a period of 2 years beginning on, and including, the day on which this Act receives the Royal Assent, it comes into operation on the first day after the end of that period.

No. 64/1995 (1) Sections 1, 2, 43 (1) and 43 (2) come into operation on the day on which this Act receives the Royal Assent.

(2) Sections 3, 4, 9, 16 to 22, 24 to 32, 33 (1), 33 (2), 33 (3), 34, 37, 39, 41, 42 and 43 (3) come into operation on 1 July 1995.

(3) Sections 10 to 15 come into operation on 1 September 1995.

(4) Sections 38 and 40 come into operation on 1 November 1995.

(5) Sections 5 to 8 and 23 come into operation on 1 November 1995.

(6) Sections 33 (4), 33 (5), 33 (6) and 33 (7) come into operation on a day or days to be proclaimed not being a day that is after 1 January 1996.

(7) Sections 35 and 36 come into operation on 31 March 1996.

No. 65/1995 (1) This Part comes into operation on the day on which this Act receives the Royal Assent.

(2) Section 14 (53) and (56) are deemed to have come into operation on 20 December 1994.

(3) Subject to sub-section (4), the remaining provisions of this Act come into operation on a day or days to be proclaimed.

(4) If a provision referred to in sub-section (3) does not come into operation within the period of 6 months beginning on, and including, the day on which this Act receives the Royal Assent, it comes into operation on the first day after the end of that period.

Mental Health Act 1986

PROCLAMATION OF THE CAULFIELD AGED PSYCHIATRY ASSESSMENT UNIT

I, Richard E. McGarvie, Governor of Victoria, acting with the advice of the Executive Council and under section 94 (2) of the **Mental Health Act 1986** and with all other enabling powers vested in me proclaim the premises known as the Caulfield Aged Psychiatry Assessment Unit indicated by cross-hachure on the accompanying plan to be an approved psychiatric unit from 1 July 1995.

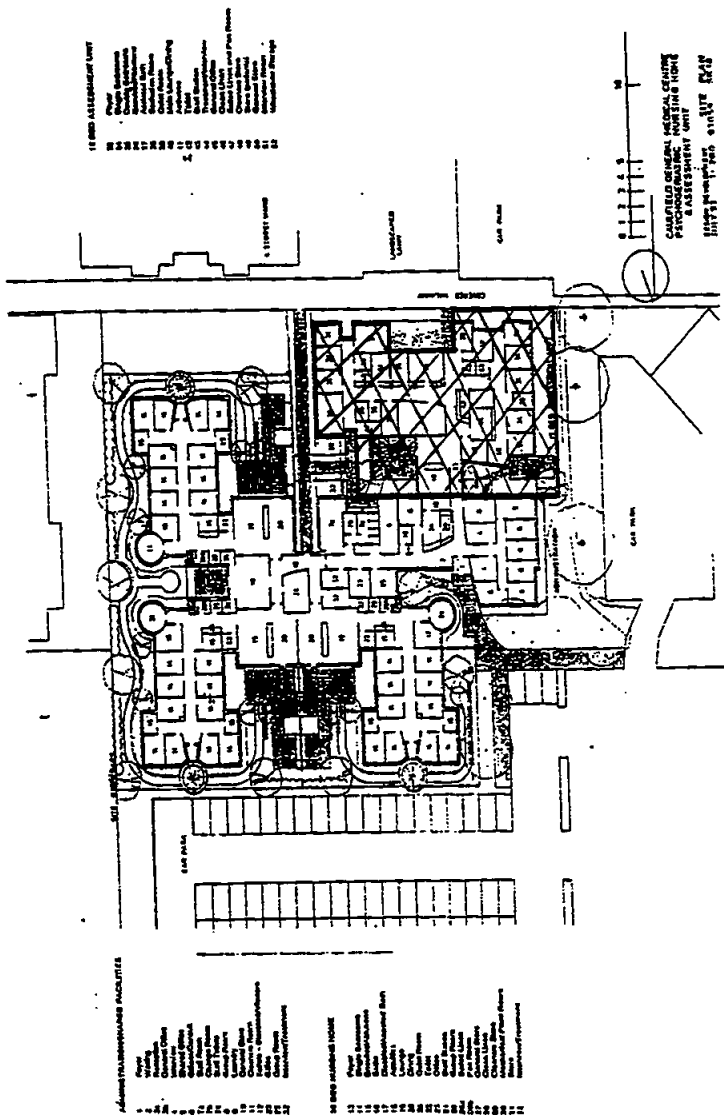

Given under my hand and the seal of Victoria on 27 June 1995

(L.S.) R. E. MCGARVIE
By His Excellency's Command

MARIE TEHAN
Minister for Health

**Occupational Health and Safety Act 1985
PROCLAMATION**

I, Richard E. McGarvie, Governor of Victoria, acting with the advice of the Executive Council and under section 2 of the **Occupational Health and Safety Act 1985**, proclaim 1 July 1995 as the date of commencement for the following items in Schedule Two of the **Occupational Health and Safety Act 1985**:

- (a) item 13; and
- (b) item 48; and
- (c) item 61.

Given under my hand and seal of Victoria
on 27 June 1995

(L.S.) R. E. McGARVIE
By His Excellency's Command

ROGER PESCOTT
Minister for Industry Services

**Water Industry (Amendment) Act 1995
PROCLAMATION OF COMMENCEMENT
OF CERTAIN PROVISIONS
Act No. 65/1995**

I, Richard E. McGarvie, Governor of Victoria, acting with the advice of the Executive Council and under section 2 (3) of the **Water Industry (Amendment) Act 1995**, fix Thursday, 29 June 1995 as the day on which the remaining provisions of that Act, except sections 16 (8), 22 (a), 22 (e), 22 (g), 22 (h), 22 (l) and 33, come into operation.

Given under my hand and the seal of
Victoria on 27 June 1995

(L.S.) R. E. McGARVIE
By His Excellency's Command

C. G. COLEMAN
Minister for Natural Resources

**Agricultural Chemicals Act 1958
PROCLAMATION**

Amendment to proclamation prescribing substances to be prohibited constituents of Agricultural Chemicals used or intended to be used for prescribed purposes

I, Richard E. McGarvie, Governor of Victoria, acting with the advice of the Executive Council and under sections 6A and 10A of the **Agricultural Chemicals Act 1958** amend with

effect from 30 June 1995 the Proclamation made on 26 March 1991 (published in the Government Gazette on 27 March 1991) prescribing certain substances to be prohibited constituents of agricultural chemicals used or intended to be used for prescribed purposes as follows:

For items 2, 6 and 13 appearing in the Schedule substitute the following entries:

SCHEDULE

<i>Column 1 Prohibited substance</i>	<i>Column 2 Purpose</i>
2. Aldrin	As an agricultural chemical.
6. Chlordane	As an agricultural chemical.
13. Heptachlor	As an agricultural chemical.

Given under my hand and the seal of
Victoria on 27 June 1995

(L.S.) R. E. McGARVIE
By His Excellency's Command

BILL McGRATH
Minister for Agriculture

**GOVERNMENT AND OUTER BUDGET SECTOR
AGENCIES NOTICES**

**WYNDHAM CITY COUNCIL
Road Discontinuance**

Under section 206 and Schedule 10, Clause 3 of the **Local Government Act 1989**, the Wyndham City Council at its meeting held on 19 June 1995, formed the opinion that such portion of road shown hatched on the plan is not reasonably required as a road for public use and resolved to discontinue the road and vest such land in the Council pursuant to section 207B of the said Act until transferred by private treaty to the owners of the abutting land.

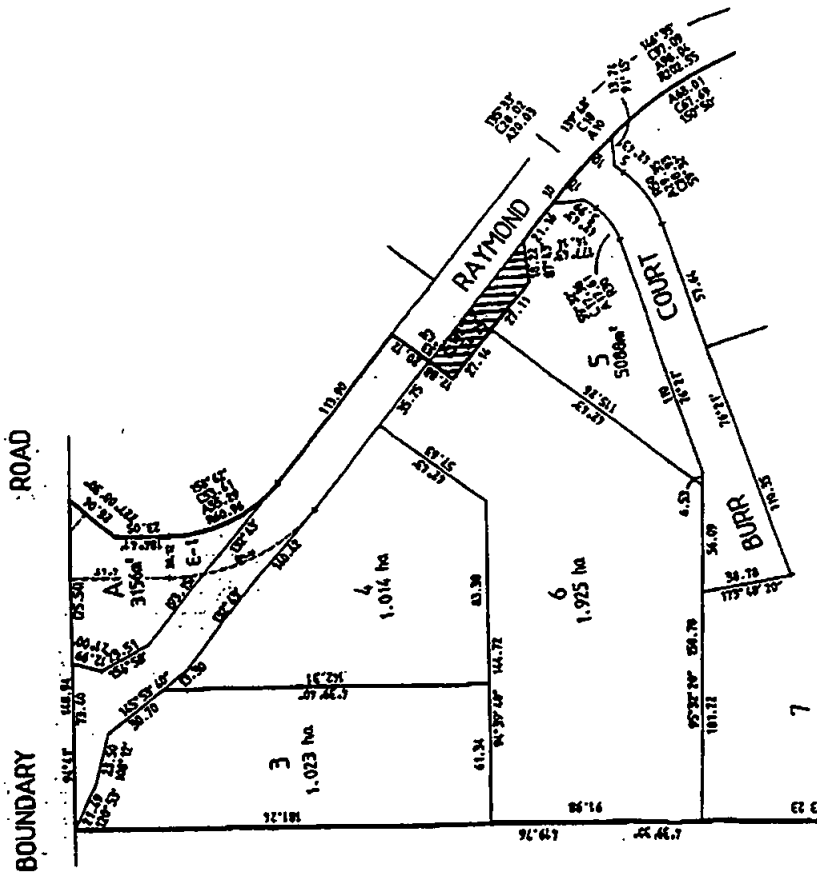

MICHAEL K. MALOUF
Chief Executive

Planning and Environment Act 1987
BRIGHT PLANNING SCHEME
Notice of Amendment to a Planning Scheme
Amendment L43

The Alpine Shire has prepared Amendment L43 to the Bright Planning Scheme.

The amendment proposes to change Chapter 2 (Ovens Valley and Kiewa Valley) of the Local Section of the Bright Planning Scheme by rezoning certain land at Tawonga presently Reserved for the purposes of the "Department of Conservation and Environment (Administration)" to Residential Medium Density.

The amendment can be inspected at the Alpine Shire, Municipal Offices, Lakeside Avenue, Mount Beauty; Department of Planning and Development, The Olderfleet Buildings, 477 Collins Street, Melbourne or at the Department of Planning and Development, 1 McKoy Street, West Wodonga.

Submissions relating to the amendment must be sent to: Attention: the Town Planner, Alpine Shire, Municipal Offices, P.O. Box 139, Bright 3741 by 1 August 1995.

ROBERT M. SLAPP
Town Planner

FINANCE UNIT LEADER

Applications are invited and will be received up to 5.00 p.m., Friday, 7 July 1995 from suitably qualified persons for the above position in the Corporate Services Department to manage Council's Finance Unit.

The Council is seeking the services of an experienced, enthusiastic, innovative and highly motivated person, who must have a good understanding of accounting procedures, in particular those that relate to Local Government. Excellent written and oral communication skills are essential.

The successful applicant can expect to develop and implement a 5 year Capital Works and Recurrent Expenditure Program, and to develop policies and procedures in relation to financial management.

The La Trobe Council is situated 150 km east of Melbourne and serves a population of approximately 75,000 people living in both an urban and rural setting.

A copy of the Job Specification can be obtained from Reception at any of the La Trobe Council Offices, located at Morwell, Moe or Traralgon or by telephoning (051) 34 4744.

Applications with envelopes endorsed 'Finance Unit Leader' must be submitted in writing and addressed to Ray Tunks, Manager—Human Resources, La Trobe Council, P.O. Box 345, Traralgon and will be received up until 5.00 p.m., Friday, 7 July 1995.

JOHN MITCHELL
Chief Executive Officer

WYNDHAM CITY COUNCIL

Local Law No. 8

Recycling Charitable Collections

Notice is hereby given in accordance with section 119 of the **Local Government Act 1989** that Council on 19 June 1995 has resolved to make Local Law No. 8 to provide for the regulation of the collection of used clothing and other goods in recycling bins and, further to establish a system of control for the location of recycling clothing bins used by charities.

Copies of the local law are available for inspection at the Civic Centre, 45 Princes Highway, Werribee during office hours.

MICHAEL K. MALOUF
Chief Executive

Planning and Environment Act 1987
DONCASTER AND TEMPLESTOWE
PLANNING SCHEME
Notice of Amendment
Amendment L84

Manningham City Council has prepared Amendment L84 to the Doncaster and Templestowe Planning Scheme.

The amendment proposes to change the planning scheme by rezoning land at 228-230 Foote Street, Templestowe from a Residential D Zone to a Residential C Zone. The rezoning would provide for the potential development of the land at a higher lot yield than that currently allowed in the Residential D Zone.

The amendment incorporates development restrictions so that a sensitive interface can be provided between the site subject to rezoning, and land to the south and east which is zoned Residential D Zone.

The amendment can be inspected at the Manningham City Council, Municipal Offices, 699 Doncaster Road, Doncaster; Department of Planning and Development, Ground Floor, the Olderfleet Buildings, 477 Collins Street, Melbourne.

1590 G 25 29 June 1995

Victoria Government Gazette

Submissions about the amendment must be sent to the Manningham City Council, PO Box 1, Doncaster, Victoria 3108. Attention: Acting Manager, Economic and Environmental Planning before 28 July 1995.

Dated 16 June 1995

BOB SIEFFERT
Chief Executive

SURF COAST SHIRE

Notice of Proposed Local Law No. 4—Roads and Streets

The Surf Coast Shire proposes to make Local Law No. 4 which is proposed to provide for the safe and orderly use of the streets and roads within the municipal district and to prohibit and regulate activities which may be dangerous, unsafe or detrimental to the amenity or quality of life in an environment of the municipal district.

A copy of the Local Law may be obtained from the Shire Offices.

Any persons affected by the proposed Local Law may make a written submission to the Council. Submissions received within 14 days of the publication of this notice will be considered by the Council in accordance with section 223 of the Local Government Act 1989. Any person requesting that she or he be heard in support of the written submission is entitled to appear before a meeting of the Council either personally or by a person acting on her or his behalf and will be notified of the time and date of the hearing.

PETER ANDERSON
Chief Executive Officer

Planning and Environment Act 1987
HORSHAM (RURAL CITY) PLANNING
SCHEME

Chapter 2—Local Section
(Formerly Horsham Planning Scheme)
Notice of an Amendment to a Planning Scheme
Amendment L3

The Horsham Rural City Council has prepared an amendment to the Horsham (Rural City) Planning Scheme—Chapter 2, Local Section (formerly the Horsham Planning Scheme).

The amendment is in 3 parts.

Part 1 affects land in Pryors Road, Horsham. The amendment proposes to rezone approximately 2.02 hectares of land from Rural C (Streamway) to Rural C (Streamway 2), so

that an application for subdivision can be considered. The 2.02 hectare lot intends to be subdivided into 4 lots, each 4000 square metres or larger. The responsible authority will assess merits of any proposal at the time of application. Also a new Clause will be introduced into the ordinance, designating the requirements the subdivision must meet, such as reticulated water, sewerage, land filled to flood level, an area designated for a house pad, and no buildings on the floodplain.

Part 2 affects land in Pryors Road/Peppertree Lane area, Horsham. The amendment proposes to rezone existing channel reserves located in the Pryors Road/Peppertree Lane area from Public Purposes—24—to various underlying zones. The land is presently owned by Council and by rezoning the land, it may allow the possibility of the land being sold to adjoining landowners to be incorporated into their titles. Also this part is effected by the closure of a road which is no longer required.

Part 3 affects land abutting the Wimmera River and between Peppertree Lane and Cameron Road, Horsham. The amendment proposes to rezone land owned by Council for the purposes of Public Open Space. The amendment will rezone the land from Rural B and Proposed Public Open Space—7—Streamway to Public Open Space—7—Streamway.

The amendment can be inspected at the Horsham Rural City Council, Roberts Avenue, Horsham; Department of Planning and Development, Central Highlands/Wimmera Office, corner Mair and Doveton Streets, Ballarat or at the Department of Planning and Development, Olderfleet Buildings, 477 Collins Street, Melbourne.

Under section 19 (1A) of the Planning and Environment Act 1987, Council has exempted itself from notifying owners and occupiers of land adjoining the channel reserves who may be affected by the amendment. Those persons are still entitled to make a submission under section 21 and 21A of the Act.

Submissions about the amendment must be sent to the Manager, Economic Development and Regulatory Services, PO Box 511, Horsham 3402 by 31 July 1995.

S. T. JERVIS
Manager, Planning and Economic Development
Horsham Rural City Council

Planning and Environment Act 1987
PRAHRAN PLANNING SCHEME
Notice of Amendment to a Planning Scheme
Amendment L62

The City of Stonnington has prepared Amendment L62 to the Local Section of the Prahran Planning Scheme. The amendment affects land at 500 Chapel Street, Prahran, commonly known as the Jam Factory.

The amendment proposes to change the planning scheme by incorporating a site specific control to allow the development and use of an Amusement Parlour on the subject land in accordance with the site specific controls as proposed in this amendment.

The amendment can be inspected at City of Stonnington, Development Work Unit (Prahran District), First Floor—Prahran Town Hall, corner Greville and Chapel Street, Prahran; Development Work Unit (Malvern District), Malvern Town Hall, corner Glenferrie Road and High Street, Malvern or at the Department of Planning and Development, Ground Floor, 477 Collins Street, Melbourne.

Submissions about the amendment must be sent to the Strategic Planning Services, City of Stonnington, PO Box 15, Malvern 3144 by 31 July 1995.

M. JACKSON
Co-ordinator
Strategic Planning Services

Planning and Environment Act 1987
NOTICE OF AMENDMENT TO A
PLANNING SCHEME

The Shire of Yarra Ranges has prepared Amendment L41 to the Upper Yarra Planning Scheme.

The amendment affects land shown on CP 16182K in Healesville Koo Wee Rup Road near the crossing at McCraes Creek.

The amendment proposes to change the Planning Scheme by allowing a density subdivision of the land.

The amendment can be inspected at the Shire of Yarra Ranges, Lilydale Office, Anderson Street, Lilydale; Healesville Office, 237 Maroondah Highway, Healesville; Yarra Junction Office, Warburton Highway, Yarra Junction; Upwey Office, Glenfern Road, Upwey or at the Department of Planning and Development, Olderfleet Building, 477 Collins Street, Melbourne.

Submissions about the amendment must be sent to the Shire of Yarra Ranges, PO Box 105, Lilydale by 4 August 1995.

**Submissions should state whether the author wishes to be heard by a Ministerial Panel if Council resolves not to uphold the submission.

E. HOWARD
Chief Executive Officer

Planning and Environment Act 1987
NOTICE OF AMENDMENT TO A
PLANNING SCHEME

The Shire of Yarra Ranges has prepared Amendment L42 to the Upper Yarra Planning Scheme.

The amendment affects land at Hall Road, McMahons Creek.

The amendment proposes to change the Planning Scheme by deleting the existing Restructure Plan No. 14 from the ordinance and substituting a new plan. The effect will be to vary the restructure pattern of Lots 20-27 Hall Road.

The amendment can be inspected at the Shire of Yarra Ranges, Lilydale Office, Anderson Street, Lilydale; Healesville Office, 237 Maroondah Highway, Healesville; Yarra Junction Office, Warburton Highway, Yarra Junction; Upwey Office, Glenfern Road, Upwey or at the Department of Planning and Development, Olderfleet Building, 477 Collins Street, Melbourne.

Submissions about the amendment must be sent to the Shire of Yarra Ranges, PO Box 105, Lilydale by 4 August 1995.

**Submissions should state whether the author wishes to be heard by a Ministerial Panel if Council resolves not to uphold the submission.

E. HOWARD
Chief Executive Officer

Planning and Environment Act 1987
CRANBOURNE PLANNING SCHEME
Notice of Amendment
Amendment L148

The City of Casey has prepared Amendment L148 to the Cranbourne Planning Scheme.

The amendment affects land at Lot D, PS 318832, south western corner of Duff Street and Monahans Road, Cranbourne.

The amendment proposes to change the planning scheme by including the site in a Commercial (Neighbourhood) Zone. This will

allow the development of a Neighbourhood Shopping Centre with a maximum retail floor area of 2500 m². A car parking ratio of 6.5 spaces per 100 m² of Gross Leasable Floor Area is to be required.

The amendment can be inspected during office hours at the City of Casey (Cranbourne Office), Cranbourne Municipal Offices, Sladen Street, Cranbourne; the City of Casey (Berwick Offices), Berwick Municipal Offices, Magid Drive, Narre Warren or at the Department of Planning and Development, Ground Floor, Olderfleet Buildings, 477 Collins Street, Melbourne.

Submissions about the amendment must be sent to the Town Planner, City of Casey, Cranbourne Office, PO Box 4, Cranbourne, Victoria 3977 by 3 August 1995.

J. SCOTT TAYLOR
Town Planner, Cranbourne Office
City of Casey

Planning and Environment Act 1987
MOORABBIN PLANNING SCHEME
Notice of an Amendment to a Planning Scheme
Amendment L54

The City of Glen Eira has prepared Amendment L54 to the Moorabbin Planning Scheme.

The amendment changes the Local Section of the Moorabbin Planning Scheme.

The amendment affects land at 2-16 Heather Street, East Bentleigh (2-8 Council carpark, 10-16 supermarket building and associated carpark).

The amendment proposes to:

- (a) Rezone land at 10-16 Heather Street from Residential C Zone to Restricted Business Zone.
- (b) Insert a site specific control into the Restricted Business Zone requiring the submission of development plans to the satisfaction of the Responsible Authority, to develop and use the land for a supermarket, associated carpark and landscaping. A concept plan is exhibited as part of the amendment.
- (c) To rearrange the Council carpark to provide for an amended layout and landscaping.

The amendment can be inspected free of charge and during office hours at the City of Glen Eira, Municipal Offices, corner Glen Eira

and Hawthorn Roads, Caulfield or at the Department of Planning and Development, Olderfleet Buildings, 477 Collins Street, Melbourne.

Submissions about the amendment must be sent to the Town Planning Office, City of Glen Eira, corner Glen Eira and Hawthorn Roads, Caulfield, Victoria 3162 by Monday, 31 July 1995.

ANDREW MILLEN
Strategic Planner

HOBSONS BAY CITY COUNCIL
Notice of Proposed Local Law No. 2

The Hobsons Bay City Council intends to make a Local Law which regulates and controls activities in relation to the Health and Environment, Roads and Streets and municipal properties of the district of Hobsons Bay. The law will include the control of activities such as and arising from disposal of waste, noise, keeping of animals, road limits, advertising and trading, beach and foreshore, incinerators, alcohol and smoking on Council properties, street parties and processions.

The Local Law also provides for the setting of fees, charges and costs, the issuing of notices to comply and permits.

A copy of the draft laws are available from the Corporate Centre, 115 Civic Parade, Altona.

Anyone who feels they are affected by the Local Law may forward a written submission to Council in accordance with section 223 of the Local Government Act and request to be heard in regard to that submission.

Written submissions must be addressed to Mr Ken McNamara, Chief Executive Officer, PO Box 21, Altona 3018, or by fax on 9316 1202 and delivered no later than Wednesday, 12 July 1995.

KEN MCNAMARA
Chief Executive Officer

Planning and Environment Act 1987
GREATER GEELONG PLANNING SCHEME
Notice of Amendment
Amendment R126

The City of Greater Geelong has prepared Amendment R126 to the Greater Geelong Planning Scheme.

The amendment proposes to change the Regional Section of the Planning Scheme by rezoning land located at the south east corner of

Forest Road South and Canterbury Road East, Lara from Rural General Farming to Rural Residential.

The development proposed includes a 15 lot rural residential subdivision ranging in size from 1.0 hectare to 3.6 hectares.

The amendment can be inspected at the City of Greater Geelong, Belmont Office, 2 Colac Road, Belmont; Department of Planning and Development, Office of Planning and Heritage, 5th Floor, State Government Offices, corner Little Malop and Fenwick Streets, Geelong or at the Department of Planning and Development, Olderfleet Buildings, 477 Collins Street, Melbourne.

Submissions about the amendment must be sent to the Planning Scheme, Amendment Unit, City of Greater Geelong, P.O. Box 104, Geelong by Monday, 31 July 1995.

CHUBB FADGYAS
Planning Scheme Manager

Planning and Environment Act 1987
NOTICE OF AMENDMENT TO A
PLANNING SCHEME

The Moira Shire Council has prepared Amendment L3 to Chapter 6 of the Moira Planning Scheme.

The amendment is described as follows:

- (a) Land being part of Lot 194 and 195 of LP 1834, situated on the corner of High and Market Streets with a Bus Depot to the west, a Doctors Surgery to the north, a vacant Residential 1 zoned lot to the east, and vacant Business 1 zoned land to the south, within the Township of Cobram. The site is to be rezoned from Residential 1 to Business 1. (approx. area 1175.9 square metres);
- (b) Land being Reserve Number 1 for Municipal Purposes on PS 314134 with, Cobram Cemetery to the west, Rural 1 zoned farming land to the north, east and south, within the Parish of Cobram. The site is to be rezoned from Rural 1 to Public Uses Cemetery (approx area 2.186 hectares);
- (c) Land being part of Lot 1 of PS 310890J with, Campbell Road to the west, Residential dwellings to the north, Residential 2 zoned land to the east and

Future Urban zoned land to the south, within the Township of Cobram. The site is to be rezoned from Future Urban to Residential 1. (approx. area 65 hectares).

The amendment can be inspected at the Moira Shire Council, Melville Street, P.O. Box 132, Numurkah; Moira Shire Council Cobram District Office, 44 Station Street, Cobram; Department of Planning and Development, the Olderfleet Buildings, 477 Collins Street, Melbourne or at the Department of Planning and Development, 1 McKoy Street, West Wodonga.

Submissions about the amendment must be sent to the Moira Shire Council at the Numurkah District Office, P.O. Box 132, Numurkah 3644, by Monday, 31 July 1995.

Planning and Environment Act 1987
MOIRA PLANNING SCHEME
Notice of Amendment to Planning Scheme
Amendment L2
(Re-exhibited)

The Moira Shire Council has prepared Amendment L2 to the Moira Planning Scheme.

The amendment reserves land in Chapters 3, 5 and 6 of the Scheme in the name of Goulburn Murray Water along the course of the Muckatah arterial drain in accordance with maps 1-16 which accompany the amendment.

The amendment can be inspected at the offices of the Department of Planning and Development, Ground Floor, the Olderfleet Building, 477 Collins Street, Melbourne; Department of Planning and Development, State Offices, 1 McKoy Street, West Wodonga; Cobram District Office, Moira Shire Council, Station Street, Cobram; Nathalia District Office, Moira Shire Council, Blake Street, Nathalia; Numurkah District Office, Moira Shire Council, Melville Street, Numurkah; Tungamah District Office, Moira Shire Council, Middleton Street, Tungamah or at the Yarrawonga District Office, Moira Shire Council, Belmore Street, Yarrawonga.

Submissions about this amendment must be sent to the Chief Executive Officer, Moira Shire Council, P.O. Box 132, Numurkah 3730 by 31 July 1995.

F. M. DARKE
Manager, Community, Regulatory and
Environmental Services

Planning and Environment Act 1987
NOTICE OF AMENDMENT TO A
PLANNING SCHEME

The City of Brimbank has prepared Amendment L93 to the Keilor Planning Scheme.

The amendment affects land described as Lot 1, LP 125675, C/T Vol. 9350, Folio 402, Dodds Road, Keilor.

It is proposed to change the Planning Scheme by rezoning the land from a Proposed Public Open Space Reservation to a Light Industrial Zone.

The amendment can be inspected at the City of Brimbank, Keilor Office, Old Calder Highway, Keilor or at the Department of Planning and Development, Plan Inspection Section, Ground Floor, Olderfleet Building, 477 Collins Street, Melbourne.

Submissions about the amendment must be sent to the City of Brimbank, Keilor Office, Old Calder Highway, Keilor 3036 by 4 August 1995.
Dated 23 June 1995

IAN PALMER
Manager/City Planner

Planning and Environment Act 1987
CAULFIELD PLANNING SCHEME
Notice of Amendment to a Planning Scheme
Amendment L37

The Glen Eira City Council has prepared Amendment L37 to the Caulfield Planning Scheme.

The amendment changes the Local Section of the Caulfield Planning Scheme.

The amendment proposes to rezone land at 70 Bambra Road, Caulfield from Residential C to Specified Areas Zone to enable the use of an historic building on the site as an office and dwelling. Use and development on the site will be regulated by a Consent Notice.

The amendment can be inspected free of charge during office hours at the Glen Eira City Council, Municipal Offices, corner Glen Eira and Hawthorn Roads, Caulfield or at the Department of Planning and Development, Olderfleet Buildings, 477 Collins Street, Melbourne.

Submissions about the amendment must be sent to the Town Planning Office, Glen Eira City Council, PO Box 42, South Caulfield, Victoria 3162 by Monday, 31 July 1995.

JEFF AKEHURST
Manager, Planning and Development

BULOKE SHIRE COUNCIL
Notice of Proposed Local Law

The Buloke Shire Council proposes to make a Local Law which will be applicable to the whole of the municipal district.

The purpose of the proposed Local Law is to regulate and control the droving of cattle through and within the municipal district of the Buloke Shire Council.

If made, the Local Law also will replace and repeal any existing Droving of Cattle Local Laws.

A copy of the proposed Local Law can be obtained from the Council Office at 367 Broadway, Wycheproof.

Any person affected by the proposed Local Law may make a submission relating to it to the Council. Submissions received by the Council within 14 days of the publication of this Notice will be considered by the Council in accordance with section 223 of the Local Government Act 1989. Any person requesting that she or he be heard in support of the written submission is entitled to appear before a meeting of the three Commissioners either personally or by a person acting on her or his behalf on 17 July 1995 at the Wycheproof Office.

PETER J. OVERINGTON
Chief Executive Officer

Planning and Environment Act 1987
TALLANGATTA PLANNING SCHEME
Notice of Amendment
Amendment L7

The Towong Shire Council has prepared Amendment L7 to the Tallangatta Planning Scheme.

The amendment is an ordinance amendment which proposes to allow the construction of a second dwelling on lot 2 LP 145594, Parish of Talgarno, on the west side of Talgarno Road, Talgarno, provided that the dwelling plans are approved by the Responsible Authority and generally in accordance with the Concept plan exhibited with the amendment.

The amendment can be inspected at the Towong Shire Council, Tallangatta Office, Towong Street, Tallangatta; Regional Office, Department of Planning and Development, 1 McKoy Street, Wodonga; Towong Shire Council, Corryong Office, Hanson Street,

Corryong or at the Department of Planning and Development, Olderfleet Building, 477 Collins Street, Melbourne.

Submissions about the amendment must be sent to the Towong Shire Council, PO Box 229, Corryong 3707 by 1 August 1995.

DAVID PARKER
Manager of Technical Services

Level, City Office, Hovell Street, Wodonga—copies may be purchased for the sum of Ten Dollars (\$10.00) each.

Information regarding the making of this By-Law may be obtained by contacting Barry O'Brien, Manager, Customer Services, telephone (060) 24 7977.

JOHN P. GOONAN
Secretary

Planning and Environment Act 1987
UPPER MURRAY PLANNING SCHEME
Notice of Amendment
Amendment L8

The Towong Shire Council has prepared Amendment L8 to the Upper Murray Planning Scheme.

The amendment is a map amendment which rezones approximately 5653 sqm of land at 5-11 Towong Road, Corryong, from Residential to Commercial A.

The amendment can be inspected at the Towong Shire Council, Tallangatta Office, Towong Street, Tallangatta; Regional Office, Department of Planning and Development, 1 McKoy Street, Wodonga; Towong Shire Council, Corryong Office, Hanson Street, Corryong or at the Department of Planning and Development, Olderfleet Building, 477 Collins Street, Melbourne.

Submissions about the amendment must be sent to the Towong Shire Council, PO Box 229, Corryong 3707 by 1 August 1995.

DAVID PARKER
Manager of Technical Services

KIEWA MURRAY WATER
Notice of Making By-Law No. 110
Water Supply and Sewerage Plumbing
Administrative By-Law

At a meeting of the Kiewa Murray Region Water Authority held 7 June 1995, the Authority agreed to the making of By-Law No. 110—Water Supply and Sewerage Plumbing Administrative By-Law.

This By-Law is about water supply and sewerage plumbing administration including procedures to be followed and the setting of fees and charges—By-Law No. 100 will come into force on 1 July 1995.

The By-Law is available for inspection during normal business hours at the Office of Kiewa Murray Region Water Authority, 3rd

**NOTICE OF ENVIRONMENT EFFECTS
STATEMENT**

Notice of Amendment: Sherbrooke Planning Scheme Amendment L86 (affecting that part of the Planning Scheme within Yarra Ranges Shire)

Notice of Amendment: Sherbrooke Planning Scheme Amendment L87 (affecting that part of the Planning Scheme within Cardinia Shire)

Notice of Amendment: Pakenham Planning Scheme Amendment L111

An Environment Effects Statement (EES) has been prepared to evaluate the environmental and social impacts of providing permanent wastewater facilities for the Emerald-Cockatoo area. The EES evaluates a number of alternative options, recommends a preferred option and identifies and assesses the environmental impacts and benefits of the preferred option, a wastewater pressure main between Cockatoo and Belgrave.

Yarra Ranges Shire Council, as planning authority, has prepared Amendment L86 to the portion of the Sherbrooke Planning Scheme which is in its municipal district.

Cardinia Shire Council, as planning authority, has prepared Amendment L87 to the portion of the Sherbrooke Planning Scheme which is in its municipal district and Amendment L111 to the Pakenham Planning Scheme.

The purpose of these amendments is to allow the construction and operation of a wastewater pressure main which will connect to the Monbulk Creek Main Sewer and hence provide permanent sewerage facilities to:

- allotments in areas which are already provided with reticulated sewerage, with sewage treated at temporary local treatment plants;

- areas for which the former Emerald District Water Board gave a commitment to provide sewerage services and which have paid a levy as a contribution to the costs associated with the future provision of such services;
- areas which have been identified by Yarra Valley Water as requiring further investigation as to the need for, and feasibility of, providing reticulated sewerage services, subject to consultation with the Council and in accordance with the Regional Strategy Plan and as described in the EES.

These amendments will jointly make changes to the relevant Planning Scheme Ordinances to provide for the planning approvals which will be required for the construction of the pressure main. They will allow the construction of the proposed pressure main (including tree removal) without the need for a planning permit provided that a Construction Management Plan and Incident Response Plan are prepared to the satisfaction of the Shire Councils, as responsible planning authorities.

The EES has been placed on public exhibition for a period of two months from 26 June 1995. The three planning scheme amendments have been placed on public exhibition concurrently with the exhibition of the EES.

A copy of the EES and these Planning Scheme Amendments can be viewed, free of charge and during business hours at Department of Planning and Development, Information Centre, Ground Floor, 477 Collins Street, Melbourne; Yarra Valley Water Office, Lucknow Street, Mitcham; Cardinia Shire, Henty Way, Pakenham; Yarra Ranges Shire: Anderson Street, Lilydale, 351 Glenferm Road, Upwey, Warburton Highway, Yarra Junction.

Copies of the EES and these Planning Scheme Amendments have also been provided at the venues listed below to give greater opportunity for them to be viewed by interested people.

- The State Library,
Reference and Information Section,
Ground Floor,
328 Swanston Street,
Melbourne, Vic 3000;
- Municipal libraries in the Shires of
Yarra Ranges and Cardinia;

- Selby Community House,
Wombalana Road, Selby 3159;
- Emerald Community House,
Main Road,
Emerald 3782;
- Mountain District Community Health
Centre,
Cookatoo.

Copies of the EES (cost \$15), Appendix of Technical Reports (cost \$15) and Summary Brochure (free) can be obtained from Yarra Valley Water. The summary brochure and this Notice are being widely circulated to Yarra Valley Water Ratepayers living adjacent to the Preferred Route, owners or occupiers of dwellings adjacent to the Preferred Route and community groups identified as having an interest in the matter. Copies of the EES have been sent to all members of the EES Consultative Committee.

Submissions in writing relating to the Planning Scheme Amendments and the EES are invited from members of the public and interested parties until 28 August 1995. Comments on the Planning Scheme Amendment should be made as, or included in, a submission on the EES. Submissions should be forwarded to Chief Assessment Officer, Department of Planning and Development, 477 Collins Street, Melbourne 3000.

Submissions directed to the Chief Assessment Officer will be regarded as having been made to the relevant planning authorities, as copies will be forwarded to the Managers of Planning at the offices of the Cardinia Shire and Yarra Ranges Shire, which are the relevant planning authorities for these Planning Scheme Amendments. Copies will also be forwarded to Yarra Valley Water. Submissions will be treated as public documents.

Following the public exhibition period and receipt of submissions, an independent panel of inquiry will be convened, if required, at which persons may be heard in respect of their submissions. Persons lodging submissions should state whether or not they wish to be heard at such a panel hearing.

After the inquiry, a report will be made to the Minister for Planning who will, in turn provide an assessment of the EES for consideration by the Cardinia and Yarra Ranges Shire Councils in deciding whether, or in what form, to adopt the Planning Scheme Amendments.

Mineral Resources Development Act 1990
NOTICE OF PARTIAL REVOCATION OF THE EXEMPTION FROM EXPLORATION
LICENCE AND/OR MINING LICENCE
No. 6/1995

I, Sidney James Plowman, Minister for Energy and Minerals, pursuant to section 7 of the **Mineral Resources Development Act 1990** hereby give notice that the exemption from exploration and/or mining licences over the land cross-hatched on the maps provided as Schedule A and Schedule B to this notice, will be revoked on Friday 21 July 1995. These areas of land were exempted as part of the "North West Initiative" and "Eastern Highlands Initiative" by notice published on pages 992-993 of the Victoria Government Gazette No. 16 dated 21 April 1994, and amended by an erratum notice published on page 1132 of the Victoria Government Gazette dated 12 May 1994.

Schedule A

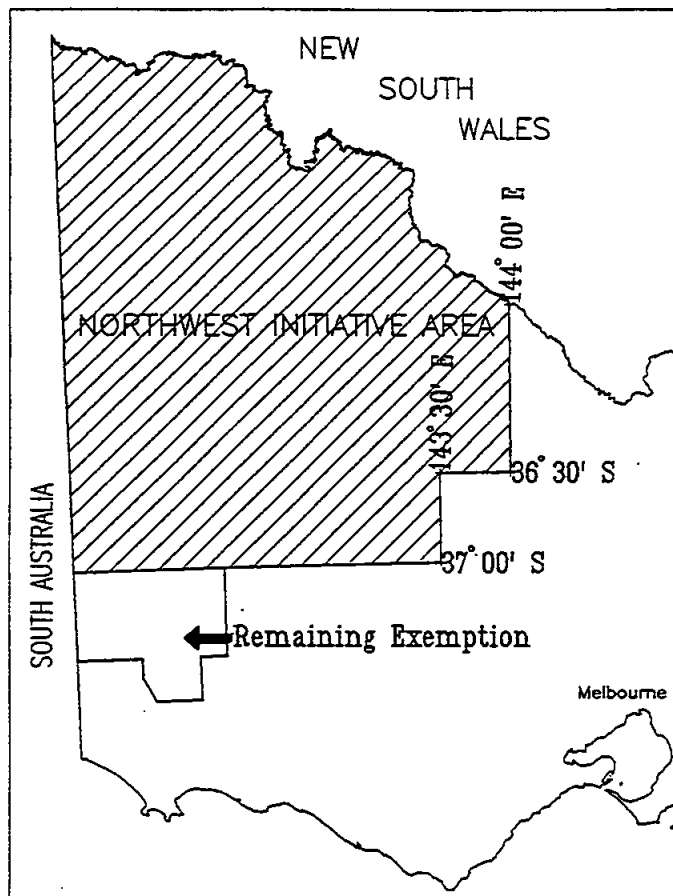

Schedule B

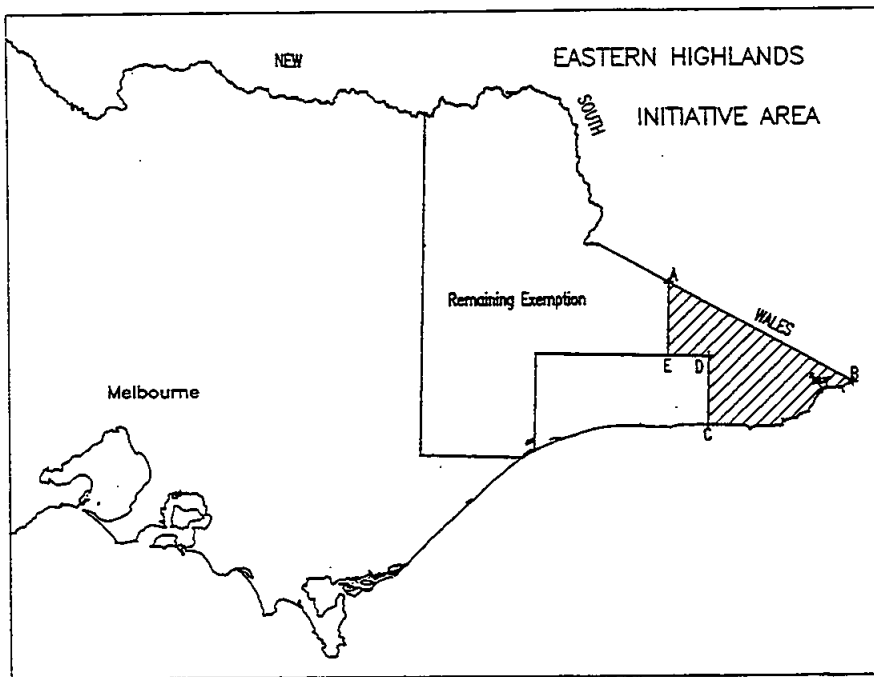

Point	AMG co-ordinates; Zone 55	
	Eastings	Northings
A	650 000	5 904 100
B	762 800	5 844 800
C	675 000	5 816 500
D	675 000	5 859 000
E	650 000	5 859 000

Dated 21 June 1995

S. J. PLOWMAN
Minister for Energy and Minerals

Water Act 1989

I, Charles Geoffrey Coleman, as Minister administering the **Water Act 1989**, make the following Order:

**APPOINTMENT OF THE GRAMPIANS
REGION WATER AUTHORITY
ORDER 1995, No. 4**

Citation

1. This Order is called the Appointment of the Grampians Region Water Authority Order 1995, No 4.

Enabling Powers

2. This Order is made under the powers conferred by Division 2 of Part 6 of the **Water Act 1989** and all other available powers.

Date of Effect

3. This Order takes effect on and from 1 July 1995.

Definitions

4. In this Order
"Act" means the **Water Act 1989**;

*Appointment of Grampians Region Water
Authority*

5. On and from the date on which this Order takes effect:

- (a) The Grampians Region Water Authority takes over the whole of the rights, liabilities, obligations, powers and functions of the Wimmera-Mallee Rural Water Authority under the Act in respect of the following water districts:
 - Eastern Mallee Urban District
 - Northern Mallee Urban District
 - Southern Mallee Urban District
 - Southern Wimmera Urban District
 - Western Wimmera Urban District;
 - and
- (b) The Warracknabeal Town Eastern Storage and urban outlet works including the land on which such water storage and outlet works are situated are transferred to and taken over by the Grampians Region Water Authority; and
- (c) With the exception of the works described in the Schedule, all the works including reticulation, meters and other minor works owned by the Wimmera-

Mallee Rural Water Authority that are situated within the districts listed in (a) and are necessary for the operation of those districts are transferred to and taken over by the Grampians Region Water Authority; and

- (d) With the exception of the property described in the Schedule, the following property owned by or vested in the Wimmera-Mallee Rural Water Authority is transferred to and taken over by the Grampians Region Water Authority:
 - (i) all land situated within and which is necessary for the operation of the districts listed in (a), including all buildings situated on such land and all rights and interests in leases and licences in respect of such land and buildings granted to or by the Wimmera-Mallee Rural Water Authority; and
 - (ii) all easements and reserves in respect of land situated within and which are necessary for the operation of the districts listed in (a); and
 - (e) With the exception of the assets described in the Schedule, all records, plans and files owned by the Wimmera-Mallee Rural Water Authority that are necessary for the operation of the districts listed in (a) and for the operation of the works described in (b), are transferred to and taken over by the Grampians Region Water Authority; and
 - (f) The loan liabilities of the Wimmera-Mallee Rural Water Authority that relate to the districts listed in (a) as at 30 June 1995 are transferred to and taken over by the Grampians Region Water Authority.
6. The following staff of Wimmera-Mallee Rural Water Authority are transferred to and become officers of Grampians Region Water Authority, pursuant to this Order and to Section 102 of the Act, and cease to be officers and employees of Wimmera-Mallee Rural Water Authority:

Butler, Trevor J
Childs, Philip S
Colyer, Allan D

1600 G 25 29 June 1995

Goodgame, Norris J
Hadley, Gaylene J
Jones, Bryan N
Livingston, George J
McKenzie, Brian W
Thomas, Christene
Whitford, William T

Pre-requisites for Making this Order

7. (a) This is an Order referred to in Section 98 (2) (a) of the Act.

(b) Under section 98 (2) (a) of the Act I have agreed the terms and conditions for the takeover made by this Order with the affected Authorities.

(c) Under section 100 (2) (a) of the Act the affected Authorities, the Wimmera-Mallee Rural Water Authority and the Grampians Region Water Authority have applied to me for the Order to be made.

SCHEDULE

Works, land and assets remaining as property of Wimmera-Mallee Rural Water Authority.

All works and buildings including associated land that are used primarily for the distribution of rural water supply.

All land that is used primarily or was obtained for the distribution of rural water supply.

All assets that are used primarily for the distribution of rural water supply including:

- (i) All water supply lines and assets servicing rural customers in the Lalbert rural pipeline area downstream of the designated point of supply to the Lalbert town water system in the Eastern Mallee Urban Water District.
- (ii) All water supply lines and assets servicing rural customers in the Rainbow West rural pipeline area downstream of the designated point of supply to the Rainbow town water system in the Western Wimmera Urban Water District.
- (iii) In the area of the Northern Mallee Rural Pipeline scheme, the Ouyen storages, the Manangatang storages and pump system upstream of the chlorinator unit and all water supply lines and other assets servicing rural customers.
- (iv) The 375 mm diameter main and syphon serving the Hindmarsh

Victoria Government Gazette

Channel at the Antwerp town water system in the Western Wimmera Urban Water District.

Dated 22 June 1995

GEOFF COLEMAN
Minister for Natural Resources

Water Act 1989

I, Charles Geoffrey Coleman, as Minister administering the Water Act 1989, make the following Order:

**TRANSFER OF WORKS TO THE COLIBAN REGION WATER AUTHORITY
ORDER 1995 No. 2**

Citation

1. This Order is called the Transfer of Works to the Coliban Region Water Authority Order 1995 No. 2.

Enabling Powers

2. This Order is made under the powers conferred by Division 2 of Part 6 of the Water Act 1989 and all other available powers.

Date of Effect

3. This Order takes effect on and from 1 July 1995.

Definitions

4. In this Order:

"Act" means the Water Act 1989.

"Authority" means the Coliban Region Water Authority.

"Body" means the Loddon Shire Council constituted as the successor body to the Shire of East Loddon and other bodies by an Order published in the Government Gazette on 19 June 1995.

Appointment of Coliban Region Water Authority

5. On and from the date on which this Order takes effect all the works used by the Loddon Shire Council in performing its functions and exercising its powers under the Local Government Act 1989 in respect of the Serpentine Water Supply and Jarklin Water Supply systems are transferred to the Authority.

Pre-requisites for Making this Order

8. (a) This is an Order referred to in section 98 (3) (a) of the Act;

(b) Under section 98 (4) (a) of the Act I have agreed the terms and conditions for the transfer made by this Order, with the Authority and the Body;

(c) Under section 100 (2) (a) of the Act the affected Authority and Body have applied to me for the Order to be made;

(d) Under section 100 (2) (b) of the Act I have consulted with the Minister administering the Local Government Act 1989 as a Council is affected; and

(e) Under section 98 (4) (b) of the Act I am satisfied that appropriate provisions have been made in relation to the disposition of the works, the rights and liabilities of the Loddon Shire Council and the manner of repayment of any money borrowed in respect of the works.

GEOFF COLEMAN
Minister for Natural Resources

WATER ACT 1989
Water (Qualification of Water Engineers)
Regulations 1992

Water Engineers' Qualifications Committee

At a meeting on 2 June 1995 the Water Engineers' Qualifications Committee established under the Regulations agreed to issue a Water Engineer's Certificate to the following applicants in accordance with the Regulations:

Hamilton, Thomas Irvine Macknight
Hoare, Phillip William
Kalaroopan, Theivanayagam
Klos, Robert Bogdan
Langcake, Christopher Charles
Wingett, Douglas Stuart

ROSS PERRY
Secretary

Water Act 1989

I, David Stringer, Director, Office of Water Reform, make the following Order:

EXTENSION OF THE LAKE BOGA URBAN
WATER DISTRICT ORDER 1995 No. 2

1. This Order is called the Extension of the Lake Boga Urban Water District Order 1995 No. 2.

2. This Order is made under section 96 (11) (b) of the Water Act 1989 and all other available powers.

3. This Order takes effect from the date of publication in the Government Gazette.

4. The proposal for the extension of the Lake Boga Urban Water District submitted to me in May 1995 is approved.

5. The Lake Boga Urban Water District is extended to include the area bordered red on the accompanying plan No. FN 95/0160/PN2, a copy of which may be inspected at the offices of the Swan Hill Water Board, situated at 73 Beveridge Street, Swan Hill.

Dated 8 June 1995

DAVID STRINGER
Director OWR as delegate of the Minister

Planning and Environment Act 1987
BAIRNSDALE (SHIRE) PLANNING
SCHEME

Notice of Approval of Amendment
Amendment L52

The Minister for Planning has approved Amendment L52 to the Bairnsdale (Shire) Planning Scheme.

The amendment comes into operation on the date this notice is published in the Government Gazette.

The amendment rezones Crown Allotment 19, Parish of Sarsfield, Deptford Road, Sarsfield, from "Existing Public Purpose—2—Mitchell Water Board" to "Broad Area Farming" and Lot 3, Lodged Plan 115312, Parish of Sarsfield, Deptford Road, Sarsfield, from "Broad Area Farming" to "Existing Public Purpose—2—Mitchell Water Board".

A copy of the amendment can be inspected free of charge during office hours at the offices of the East Gippsland Shire Council, Bairnsdale Business Centre, 273 Main Street, Bairnsdale and at the Department of Planning and Development, 477 Collins Street, Melbourne.

GEOFF CODE
Manager

Planning Co-ordination Branch
Department of Planning and Development

Planning and Environment Act 1987
BULN BULN PLANNING SCHEME

Notice of Approval of Amendment
Amendment L40

The Minister for Planning has approved Amendment L40 to the Buln Buln Planning Scheme.

1602 G 25 29 June 1995

Victoria Government Gazette

The amendment comes into operation on the date this notice is published in the Government Gazette.

The amendment:

Introduces a definition for "Tourist Establishment" which would be permitted in all zones except the "Light Industrial" Zone; Changes the planning scheme so that farming is allowed without a planning permit in the "Rural Residential" and "Country Club Residential" Zones; Allows "Bed and Breakfast" accommodation subject to the conditions in Clause 9-1 of the State Section of the Buln Buln Planning Scheme.

A copy of the amendment can be inspected free of charge during office hours at the offices of the Baw Baw Shire, Buln Buln Office, 33 Young Street, Drouin and at the Department of Planning and Development, 477 Collins Street, Melbourne.

GEOFF CODE
Manager
Planning Co-ordination Branch
Department of Planning and Development

Planning and Environment Act 1987
GREATER GEELONG PLANNING SCHEME
Notice of Approval of Amendment
Amendment RL87

The Minister for Planning has approved Amendment RL87 to the Greater Geelong Planning Scheme.

The amendment comes into operation on the date this notice is published in the Government Gazette.

The amendment rezones land bounded by the Princes Highway, Anglesea Road and Lemins Road and between the Princes Highway, Cochranes Road and the Waurn Ponds Creek, Waurn Ponds, from Rural General Farming zone to Rural Residential zone.

A copy of the amendment can be inspected free of charge during office hours at the Department of Planning and Development, Planning Division, Ground Floor, Olderfleet Buildings, 477 Collins Street, Melbourne; and at the City of Greater Geelong, Belmont Office, 2 Colac Road, Belmont.

GEOFF CODE
Manager
Planning Co-ordination Branch
Department of Planning and Development

Planning and Environment Act 1987
MOIRA PLANNING SCHEME
Notice of Approval of Amendment
Moirā Amalgamation Amendment

The Minister for Planning has approved the above amendment to the Nathalia Planning Scheme.

The amendment comes into operation on the date this notice is published in the Government Gazette.

The amendment is to the Nathalia Planning Scheme, incorporating the Local Sections of the Nathalia, Numurkah (Chapters 1 and 2), Cobram, Yarrawonga (except for the township of Peechelba) Planning Schemes, and part of the Tungamah Planning Scheme as Chapters 2 to 7 of the Moira Planning Scheme. This amendment also creates a new Chapter 1 to apply to the whole of the Shire of Moira. The amendment deletes all the provisions of the former Numurkah, Cobram, Yarrawonga Planning Schemes and the Tungamah Planning Scheme as it applies within the Moira Shire. The amendment also revokes the former Numurkah, Cobram, and Yarrawonga Planning Schemes.

The amendment does not change the planning provisions applying to land in the Shire of Moira. Its purpose is to provide a consolidated planning scheme as required as a consequence of the restructure of municipal boundaries of the former Shires (and parts of Shires) which now form part of the Shire of Moira.

A copy of the amendment can be inspected free of charge during office hours at the Department of Planning and Development, Ground Floor, 477 Collins Street, Melbourne and at the offices of the Numurkah District Office, Melville Street, Numurkah.

GEOFF CODE
Manager
Planning Co-ordination Branch
Department of Planning and Development

Planning and Environment Act 1987
PHILLIP ISLAND PLANNING SCHEME
Notice of Approval of Amendment
Amendment L60

The Minister for Planning has approved Amendment L60 to the Phillip Island Planning Scheme.

The amendment comes into operation on the date this notice is published in the Government Gazette.

The amendment introduces a new Clause 111-6.5 to control the use and development of part Crown Allotment 129, Back Beach Road, Phillip Island, and exempts this land from "Rural A" zone provisions relating to the minimum lot size required for the construction of a house.

A copy of the amendment can be inspected free of charge during office hours at the offices of the Bass Coast Shire, Phillip Island Office, 91-97 Thompson Avenue, Phillip Island and at the Department of Planning and Development, 477 Collins Street, Melbourne.

GEOFF CODE
Manager
Planning Co-ordination Branch
Department of Planning and Development

The amendment comes into operation on the date this notice is published in the Government Gazette.

The amendment adds a new clause 26 (3) to allow excision of a lot containing an existing house from a horticultural block in Damascus Road, Robinvale.

A copy of the amendment can be inspected free of charge during office hours at the Department of Planning and Development, Ground Floor 477 Collins Street, Melbourne; 426 Hargreaves Street, Bendigo and at the Swan Hill Rural City, 45 Splatt Street, Swan Hill.

GEOFF CODE
Manager
Planning Co-ordination Branch
Department of Planning and Development

Planning and Environment Act 1987
SALE PLANNING SCHEME
Notice of Approval of Amendment
Amendment L28

The Minister for Planning has approved Amendment L28 to the Sale Planning Scheme.

The amendment comes into operation on the date this notice is published in the Government Gazette.

The amendment deletes the terms "Post office" and "Mail centre" from the prohibited section in the Highway Commercial zone. These two uses will therefore be allowed in this zone with the issue of a planning permit.

A copy of the amendment can be inspected free of charge during office hours at the offices of the Wellington Shire Council, Sale Office, 70 Foster Street, Sale, and at the Department of Planning and Development, 477 Collins Street, Melbourne.

GEOFF CODE
Manager
Planning Co-ordination Branch
Department of Planning and Development

Planning and Environment Act 1987
SWAN HILL SHIRE PLANNING SCHEME
Notice of Approval of Amendment
Amendment L19

The Minister for Planning has approved Amendment L19 to the Swan Hill Shire Planning Scheme.

Planning and Environment Act 1987
WODONGA PLANNING SCHEME
Notice of Lapsing of Amendment
Amendment L69

The Wodonga City Council has resolved to abandon Amendment L69 to the Wodonga Planning Scheme.

The amendment was an ordinance only amendment affecting land in the Residential "C" zone which deleted specific reference to the Carrington Park Overall Development Plan in favour of a requirement that all subdivisions be generally in accordance with stated performance criteria.

The amendment lapsed on 23 February 1995.

GEOFF CODE
Manager
Planning Co-ordination Branch
Department of Planning and Development

Planning and Environment Act 1987
SOUTH MELBOURNE PLANNING SCHEME

Notice of Approval of Amendment
Amendment L101

The Minister for Planning has approved Amendment L101 to the Local Section of the South Melbourne Planning Scheme.

The amendment comes into operation on the date this notice is published in the Government Gazette.

1604 G 25 29 June 1995

The amendment proposes to include a site specific clause which allows development of land at 16-18 Albert Road, South Melbourne to exceed the permissible plot ratio provided that the resultant increase relates to floor area at ground level of not more than 50 square metres and is to the satisfaction of the responsible authority.

A copy of the amendment can be inspected free of charge during office hours at the Department of Planning and Development, Ground Floor, 477 Collins Street, Melbourne and at the South Melbourne office of the City of Port Phillip, Town Hall, Bank Street, South Melbourne.

GEOFF CODE
Manager
Planning Co-ordination Branch
Department of Planning and Development

**Planning and Environment Act 1987
HAWTHORN PLANNING SCHEME
Notice of Approval of Amendment
Amendment L34**

The Minister for Planning has approved Amendment L34 to the Local Section of the Hawthorn Planning Scheme.

The amendment comes into operation on the date this notice is published in the Government Gazette.

The amendment rezones part of three properties situated to the north west corner of Tooronga Road and Kaikoura Avenue, Glen Iris from Residential C zone to a Proposed Road Widening reservation to allow for the acquisition of part of the properties.

The amendment forms the second part of the overall approval given by the Minister for Planning for the South Eastern Arterial Grade Separations Project.

A copy of the amendment can be inspected free of charge during office hours at the offices of the City of Boroondara, Municipal Office, Inglesby Road, Camberwell and at the Department of Planning and Development, 477 Collins Street, Melbourne.

GEOFF CODE
Manager
Planning Co-ordination Branch
Department of Planning and Development

Victoria Government Gazette

**Planning and Environment Act 1987
HAWTHORN PLANNING SCHEME
Notice of Approval of Amendment
Amendment L35**

The Minister for Planning has approved Amendment L35 to the Local Section of the Hawthorn Planning Scheme.

The amendment comes into operation on the date this notice is published in the Government Gazette.

The amendment inserts a site specific clause into the Residential C Zone of the Planning Scheme Ordinance to enable the construction of additions to the rear of the dwelling at 5 Camarvon Street, East Hawthorn for which a building dispensation was issued on 31 March 1994.

A copy of the amendment can be inspected free of charge during office hours at the offices of the City of Boroondara (Camberwell Office), 8 Inglesby Road, Camberwell and at the Department of Planning and Development, 477 Collins Street, Melbourne.

GEOFF CODE
Manager
Planning Co-ordination Branch
Department of Planning and Development

**Planning and Environment Act 1987
CROYDON PLANNING SCHEME
Notice of Approval of Amendment
Amendment L63**

The Minister for Planning has approved Amendment L63 to the Local Section of the Croydon Planning Scheme.

The amendment comes into operation on the date this notice is published in the Government Gazette.

The amendment:

- Removes a restrictive covenant which applies to 26 Mount Dandenong Road, being Lot 1, LP 221882T, Croydon to enable the land to be developed and used for the purpose of a dual occupancy development.
- Allows the land to be used and developed for a dual occupancy and subdivision into two lots without a planning permit subject to conditions

and plans referred to in an Incorporated Document in the Croydon Planning Scheme under section 6 (2) (j) of the **Planning and Environment Act 1987** in the Incorporated Document section of the planning scheme.

A copy of the amendment can be inspected free of charge during office hours at the offices of the City of Maroondah (Croydon Office), Civic Centre, Croydon and at the Department of Planning and Development, 477 Collins Street, Melbourne.

GEOFF CODE
Manager
Planning Co-ordination Branch
Department of Planning and Development

Planning and Environment Act 1987
GREATER GEELONG PLANNING SCHEME
Notice of Approval of Amendment
Amendment RL114

The Minister for Planning has approved, with changes, Amendment RL114 to the Greater Geelong Planning Scheme. This amendment was formerly known as Amendment L114

The amendment comes into operation on the date this notice is published in the Government Gazette.

The amendment rezones land at 315-323 LaTrobe Terrace, Geelong to Business 5 zone as detailed in Clause 6I of the State Section of the Scheme, and inserts 'site specific' provisions in the Local Section which enables a permit to be considered for the use and development of land at 315-323 LaTrobe Terrace, Geelong for Motor Vehicle Sales consistent with an Agreement under section 173 of the Act.

A copy of the amendment can be inspected free of charge during office hours at the Department of Planning and Development, Planning Division, Ground Floor, Olderfleet Buildings, 477 Collins Street, Melbourne or at the City of Greater Geelong, Development Approvals and Local Laws Administration, 2 Colac Road, Belmont.

GEOFF CODE
Manager
Planning Co-ordination Branch
Department of Planning and Development

Planning and Environment Act 1987
ESSENDON PLANNING SCHEME
Notice of Approval of Amendment
Amendment L64

The Minister for Planning has approved Amendment L64 to the Local Section of the Essendon Planning Scheme.

The amendment comes into operation on the date this notice is published in the Government Gazette.

The amendment rezones land bounded by Dean Street, McPherson Street and Alexandra Avenue, Moonee Ponds to a District Centre Moonee Ponds No. 2 zone and introduces a site specific control to allow the development and use of the site for the Foxtel National Customer Service Centre.

A copy of the amendment can be inspected free of charge during office hours at the Department of Planning and Development, 477 Collins Street, Melbourne and at the offices of the Moonee Valley City Council, City Development Offices, 707 Mount Alexander Road, Moonee Ponds.

GEOFF CODE
Manager
Planning Co-ordination Branch
Department of Planning and Development

Planning and Environment Act 1987
GREATER GEELONG PLANNING SCHEME
Notice of Approval of Amendment
Amendment RL119

The Minister for Planning has approved Amendment RL119 to the Greater Geelong Planning Scheme.

The amendment comes into operation on the date this notice is published in the Government Gazette.

The amendment rezones land on the north-east corner of the Bellarine Highway and Wilsons Road, Newcomb, from Public Purposes 2 (Local Government) Reservation to District Business zone and inserts a site specific clause into the Scheme to recognise the future use and ownership of the land and to enable expansion of the existing commercial/retail/community facilities.

A copy of the amendment can be inspected free of charge during office hours at the Department of Planning and Development,

1606 G 25 29 June 1995

Planning Division, Ground Floor, Olderfleet Buildings, 477 Collins Street, Melbourne or at the City of Greater Geelong, Belmont Office, 2 Colac Road, Belmont.

GEOFF CODE
Manager

Planning Co-ordination Branch
Department of Planning and Development

DEPARTMENT OF AGRICULTURE,
ENERGY AND MINERALS

All titles are located on the 1:100,000 mapsheet listed with each title.

EXPLORATION LICENCE GRANTED

No. 3750; Metex Resources NL; 63 grats, Ballarat.

EXPLORATION LICENCE RENEWED

No. 3377; Fortunee Gold NL; 250 grats, Creswick.

EXPLORATION LICENCE SURRENDERED

No. 3556; CRA Exploration P/L; 496 grats, Bendock and Murrindal.

No. 3557; CRA Exploration P/L; 488 grats, Bendock and Murrungowar.

No. 3645; CRA Exploration P/L; 405 grats, Bendock, Murrungowar and Orbost.

MINING LICENCE GRANTED

No. 4814; Sedimentary Holdings Ltd; 72.82 hectares, Beaufort.

MINING LICENCE REFUSED

No. 4998; Doleham Pty Ltd; 6.03 hectares, Creswick.

No. 4999; Doleham Pty Ltd; 9.12 hectares, Creswick.

No. 5000; Doleham Pty Ltd; 7.52 hectares, Creswick.

No. 5001; Doleham Pty Ltd; 200.14 hectares, Creswick.

No. 5002; Doleham Pty Ltd; 1.6 hectares, Creswick.

MINING LICENCE RENEWED

No. 4899; Kevin D. Simons; 5 hectares, Matlock.

MINING LICENCE SURRENDERED

No. 4439; Ranger Gold P/L; 6.99 hectares, Bendigo.

Victoria Government Gazette

MINING LEASE SURRENDERED

No. 1916; Barry Richard Crabbe; 61.33 hectares, Nyah.

MINERS RIGHT CLAIM SURRENDERED

No. 1267; Arthur Frederick Campbell; 1 hectare, Bacchus Marsh.

No. 1268; Thelma M. Campbell; 1 hectare, Bacchus Marsh.

No. 1609; Heather May Simmons; 1 hectare, Bacchus Marsh.

EXTRACTIVE INDUSTRY LEASE
APPLICATION ASSIGNED

No. 437; Sabrute P/L to Commercial Minerals Limited; 24.85 hectares, Warragul.

ROAD SAFETY (PROCEDURES)
(LICENCE CLASSIFICATION)
REGULATIONS 1995

In accordance with the provisions of the Subordinate Legislation Act 1994, notice is given of the proposal to make regulations to be known as the Road Safety (Procedures) (Licence Classification) Regulations 1995.

A Regulatory Impact Statement has been prepared as required under the Subordinate Legislation Act.

The objective of the proposed Regulations is to increase road safety and reduce the administration costs of road transport through a strategy at providing a set of nationally uniform or consistent requirements relating to the licence classifications for drivers of heavy vehicles greater than 4.5 tonnes gross vehicle mass.

The Regulatory Impact Statement may be obtained by telephoning (03) 9854 2336.

Comments and submissions are invited from interested parties and should be forwarded to: Manager—Driver Licensing, Roads Corporation, 1st Floor, 60 Denmark Street, Kew Victoria 3101.

Any enquiries regarding the content of the statement should be directed to Sandra Torpey (03) 9854 2036 or Chris Nolan (03) 9854 2056.

The closing date for submissions is 22 July 1995.

COLIN JORDAN
Chief Executive

**Transport Act 1983
ROADS CORPORATION**

Commercial Passenger Vehicle Applications

Notice is hereby given that the following applications will be considered by the Roads Corporation after 2 August 1995.

Notice of any objection to the granting of an application should be forwarded to reach the Section Leader, Vehicle Licensing or any District Office of the Roads Corporation not later than 20 July 1995.

It will not be necessary for interested parties to appear on the date specified, unless advised in writing by the Corporation.

K. R. Kendrick, Mount Waverley. Application for variation of conditions of licence number SV1408 which authorises the licensed vehicle to operate as a special purpose vehicle in respect of a 1965 Cadillac convertible with seating capacity for 4 passengers to change the vehicle to a 1992 or later model Cadillac stretched limousine or similar vehicle with seating capacity for 8 passengers.

D. M. Mills, Moonee Ponds. Application to license one commercial passenger vehicle in respect of a 1983 or later model Cadillac sedan or similar vehicle with seating capacity for 5 passengers to operate as a special purpose vehicle from 7/48 Evans Street, Moonee Ponds for the carriage of passengers for wedding parties, tourist activities and special occasions.

M. E. and E. Theiler, North Fitzroy. Application to license one commercial passenger vehicle licence in respect of a 1965 or later model Chevrolet convertible or similar vehicle with seating capacity for 5 passengers to operate as a special purpose vehicle for the carriage of passengers for various tours to places of interest throughout the State of Victoria.

Dated 29 June 1995

JEFF DALMAN
Section Leader, Vehicle Licensing

**Transport Act 1983
ROADS CORPORATION**
Tow Truck Applications

Notice is hereby given that the following applications will be considered by the Department of Transport after 2 August 1995.

Notice of any objection to the granting of an application should be forwarded to reach the Secretary of Transport, care of Roads

Corporation, Vehicle Licensing or any of their District Offices not later than 20 July 1995.

It will not be necessary for interested parties to appear on the date specified, unless advised in writing by the Secretary.

D. R. Wyatt, Mulgrave. Application for variation of the conditions of tow truck licence number 040 which authorises the licensed vehicle to be controlled and operated from a depot situated at 23 McDonalds Lane, Mulgrave to change the depot address to 41 Ricketts Road, Mount Waverley.

Dated 29 June 1995

JOHN McMILLAN
Secretary of Transport

**Transport Act 1983
ROADS CORPORATION**

Commercial Passenger Vehicle Applications

Notice is hereby given that the following application will be considered by the Roads Corporation after 2 August 1995.

Notice of any objection to the granting of an application should be forwarded to reach the Manager, Registration and Licensing, PO Box 82, Wendouree 3355 not later than 27 July 1995.

Yeltron Pty Ltd, Smeaton, Victoria. Application to license one commercial passenger vehicle in respect of a 1983 four wheel drive Mercedes Benz Unimog Bus with seating capacity for 21 passengers to operate as a special service vehicle for the carriage of passengers on various tours, four wheel drive excursions and camping throughout the State of Victoria.

Fares: By agreement with the hirer.

Timetable: As and when required.

Dated 29 June 1995

JOHN WILSON
Regional Manager, Western Region

**Department of Treasury and Finance
SALE OF CROWN LAND BY PUBLIC
AUCTION**

On Saturday, 12 August 1995.

Lot 1: 12.30 p.m. on site.

Property Address: Off Deep Springs Road, Eganstown.

Crown Description: Allotment 95K7 Section B Parish of Bullarook.

Area: 7148 m².

Ref: 92-1154.

1608 G 25 29 June 1995

Lot 2: 1.30 p.m. on site.
Property Address: Fulcher Street,
Daylesford.

Crown Description: Allotment 14 Section
25A Township of Daylesford West.

Area: 1878 m².

Ref: L3-970.

Lot 3: 2.15 p.m. on site.
Property Address: Fronting unmade
Stanhope Street, Daylesford.

Crown Description: Allotment 9 Section
19B Township of Daylesford.

Area: 3287 m².

Ref: P140100.

Terms of Sale: 10% deposit, balance 60
days.

Co-ordinating Officer: Graeme Barnes, Sales
Officer, Department of Conservation and Natural
Resources, Ballarat. Phone (053) 33 6705.

Selling Agent: Kaye Pickering, Doepel
Lilley & Taylor, 41 Vincent Street, Daylesford.
Phone (053) 48 3151.

ROGER HALLAM
Minister for Finance

Department of Treasury and Finance
SALE OF CROWN LAND BY PUBLIC
AUCTION

Reference P042455

Tenders close 2.00 p.m., Thursday, 27 July
1995.

Property Address: Corner Hamilton-Port
Fairy Road and Old Dunmore Road, Orford.

Crown Description: Allotment 2 Section 4
Township of Orford.

Area: 6007 square metres.

Terms of Sale: 10% deposit, balance 60
days.

Tenders: addressed to—Crown Land Sales
Tender Box ref: P042455, Department of
Conservation and Natural Resources, 17
Thompson Street, Hamilton.

Tender Deposit: 10% of tendered amount to
be lodged with tender.

Application Form: Available on request.

Co-ordinating Officer: Stewart Beaton,
Land Sales Officer, Department of Conservation
and Natural Resources, Hamilton. Telephone
(055) 72 3033.

ROGER M. HALLAM
Minister for Finance

Victoria Government Gazette

Department of Treasury and Finance
SALE OF CROWN LAND BY PUBLIC
AUCTION

Reference P081627

On Friday, 21 July 1995 at 2.00 p.m. on site.
Address of Property: Meiklejohn Street,
Camperdown.

Crown Description: Allotment 23,
Township of Camperdown.

Area: 4755 square metres.

Term of Sale: 10% deposit, balance 60 days.

Co-ordinating Officer: Graeme Barnes,
Land Sales Officer, Department of
Conservation and Natural Resources, Ballarat.

Selling Agent: Daryl O'Donohue, James H.
Monk Real Estate Pty Ltd, 128 Manifold Street,
Camperdown 3260. Telephone (055) 93 1188.

ROGER M. HALLAM
Minister for Finance

Department of Finance
SALE OF CROWN LAND BY PUBLIC
TENDER

Tenders close 2.00 p.m., Tuesday, 1 August
1995.

Property Address: 10 Day Street, Tongala.

Crown Description: Allotment 14, Section
H, Township of Tongala.

Area: 1188 square metres.

Term of Sale: 10% deposit—balance 60
days.

Tenders: addressed to—Land Sales Tender
Box, (Ref: P162498) Department of
Conservation and Natural Resources, "Tara
Court", Ford Street, Wangaratta 3677.

Tender Deposit: 10% of tendered amount to
be lodged with tender.

Application Form: Available on request.

Co-ordinating Officer: Frank Holt, Land
Sales Officer, Department of Conservation and
Natural Resources, Wangaratta, Telephone
(057) 21 5022.

ROGER M. HALLAM
Minister for Finance

County Court Act 1958
ADDITIONAL COUNTY COURT
SITTING 1995

Notice is given that an additional sitting of the
County Court of Victoria will be held at Geelong
to commence on Monday, 3 July 1995.

G. R. D. WALDRON
Chief Judge of the County Court of Victoria

**County Court Act 1958
ADDITIONAL COUNTY COURT
SITTING 1995**

Notice is given that an additional sitting of the County Court of Victoria will be held at:

Horsham—Monday, 3 July 1995
Bendigo—Monday, 10 July 1995
Shepparton—Monday, 17 July 1995
Ballarat—Monday, 24 July 1995

G. R. D. WALDRON
Chief Judge of the County Court of Victoria

**County Court Act 1958
ADDITIONAL COUNTY COURT
SITTING 1995**

Notice is given that an additional sitting of the County Court of Victoria will be held at Morwell to commence on Monday, 17 July 1995.

G. R. D. WALDRON
Chief Judge of the County Court of Victoria

**Land Acquisition and Compensation
Act 1986
Transport Act 1983
NOTICE OF ACQUISITION**

Compulsory Acquisition of Interest in Land
The Roads Corporation declares that by this notice it acquires the following interests in the land described hereunder:

Owners' Names: G., A., P. & E. George.

Description of Land: being part of Lots 25, 26 and 27 on Plan of Subdivision 13699 in the Parish of Bulleen.

Area: 76 square metres.

Title Details: Certificate of Title Volume 8506 Folio 902.

Survey Plan No.: 19026.

The survey plan referred to in this notice may be viewed at Property Services Department, VIC ROADS, 4th Floor, Materials Building, 60 Denmark Street, Kew.

Published with the authority of the Roads Corporation and the Minister for Roads and Ports.

T. H. HOLDEN
Manager, Property Services
Roads Corporation

**Land Acquisition and Compensation
Act 1986**

Transport Act 1983

NOTICE OF ACQUISITION

Compulsory Acquisition of Interest in Land

The Roads Corporation declares that by this notice it acquires the following interest in the land described hereunder:

Owner's Name: Amoco Australia Pty Ltd (now known as BP Australia Limited).

Description of Land: being part of Lots 120 and 121 on Plan of Subdivision 11354 in the Parish of Bulleen.

Area: 88 square metres.

Title Details: Certificate of Title Volume 8623 Folio 248.

Survey Plan No.: 19028.

The survey plan referred to in this notice may be viewed at Property Services Department, VIC ROADS, 4th Floor, Materials Building, 60 Denmark Street, Kew.

Published with the authority of the Roads Corporation and the Minister for Roads and Ports.

T. H. HOLDEN
Manager, Property Services
Roads Corporation

**Land Acquisition and Compensation
Act 1986**

Transport Act 1983

NOTICE OF ACQUISITION

Compulsory Acquisition of Interest in Land

The Roads Corporation declares that by this notice it acquires the following interests in the land described hereunder:

Owners' Names: D. & A. Spizzica.

Description of Land: being part of the land contained in Plan of Consolidation No. 157900N in the Parish of Bulleen.

Area: 262 square metres.

Title Details: Certificate of Title Volume 9787 Folio 753.

Survey Plan No.: 19027.

The survey plan referred to in this notice may be viewed at Property Services Department, VIC ROADS, 4th Floor, Materials Building, 60 Denmark Street, Kew.

Published with the authority of the Roads Corporation and the Minister for Roads and Ports.

T. H. HOLDEN
Manager, Property Services
Roads Corporation

**Land Acquisition and Compensation
Act 1986**

Transport Act 1983

NOTICE OF ACQUISITION

Compulsory Acquisition of Interest in Land

The Roads Corporation declares that by this notice it acquires the following interests in the land described hereunder:

Owners' Names: The Mayor Councillors and Citizens of the City of Doncaster and Templestowe.

Description of Land: being part of Lots 96, 97, 98, 99, 100, 101, 32 and 33 on Plan of Subdivision 10781 in the Parish of Bulleen.

Area: 1,352 square metres.

Title Details: Certificates of Title Volume 6911 Folio 076, Volume 5362 Folio 381, Volume 9660 Folio 767, Volume 5585 Folio 823, Volume 6566 Folio 025, Volume 7139 Folio 605, Volume 9168 Folio 556 and Volume 9168 Folio 557.

Survey Plan No.: 19028 and 19027.

The survey plan referred to in this notice may be viewed at Property Services Department, VIC ROADS, 4th Floor, Materials Building, 60 Denmark Street, Kew.

Published with the authority of the Roads Corporation and the Minister for Roads and Ports.

T. H. HOLDEN
Manager, Property Services
Roads Corporation

The survey plan referred to in this notice may be viewed at Property Services Department, VIC ROADS, 4th Floor, Materials Building, 60 Denmark Street, Kew.

Published with the authority of the Roads Corporation and the Minister for Roads and Ports.

T. H. HOLDEN
Manager, Property Services
Roads Corporation

**Land Acquisition and Compensation
Act 1986**

Transport Act 1983

NOTICE OF ACQUISITION

Compulsory Acquisition of Interest in Land

The Roads Corporation declares that by this notice it acquires the following interest in the land described hereunder:

Owner's Name: Kenna Lake Pty Ltd.

Description of Land: being part of Lots 23 and 24 on Plan of Subdivision 13699 in the Parish of Bulleen.

Area: 4 square metres.

Title Details: Certificates of Title Volume 9239 Folios 903 and 904.

Survey Plan No.: 19026.

The survey plan referred to in this notice may be viewed at Property Services Department, VIC ROADS, 4th Floor, Materials Building, 60 Denmark Street, Kew.

Published with the authority of the Roads Corporation and the Minister for Roads and Ports.

T. H. HOLDEN
Manager, Property Services
Roads Corporation

**Land Acquisition and Compensation
Act 1986**

Transport Act 1983

NOTICE OF ACQUISITION

Compulsory Acquisition of Interest in Land

The Roads Corporation declares that by this notice it acquires the following interest in the land described hereunder:

Interested Party: B., L. and M. Grollo Holdings Pty Ltd.

Description of Land: being part of Lots 14, 15 and 22 on Plan of Subdivision 13699 and part of lots 28 to 32 (both inclusive) on Plan of Subdivision No. 13803 in the Parish of Bulleen.

Area: 377 square metres.

Title Details: Certificates of Title Volume 9050 Folios 113 and 114 Volume 7456 Folios 066 and 067.

Survey Plan No.: 19025.

**Land Acquisition and Compensation
Act 1986**

Transport Act 1983

NOTICE OF ACQUISITION

Compulsory Acquisition of Interest in Land

The Roads Corporation declares that by this notice it acquires the following interests in the land described hereunder:

Owners' Names: Mr R. A. and Mrs V. J. Carroll.

Description of Land: Part of Lot 124 on Plan of Subdivision No. 11354, Parish of Bulleen.

Area: 24 square metres.

Victoria Government Gazette

Title Details: Certificate of Title Volume 7109 Folio 755.

Survey Plan No.: 19028 (Parcel 18).

The survey plan referred to in this notice may be viewed at Property Services Department, VIC ROADS, 4th Floor, Materials Building, 60 Denmark Street, Kew.

Published with the authority of the Roads Corporation and the Minister for Roads and Ports.

T. H. HOLDEN
Manager, Property Services
Roads Corporation

**Land Acquisition and Compensation
Act 1986**

Transport Act 1983

NOTICE OF ACQUISITION

Compulsory Acquisition of Interest in Land

The Roads Corporation declares that by this notice it acquires the following interests in the land described hereunder:

Owner's Name: Ivy Christina Feruglio.

Description of Land: Part of Lot 37 on Plan of Subdivision No. 13173, Parish of Bulleen.

Area: 58 square metres.

Title Details: Certificate of Title Volume 5665 Folio 853.

Survey Plan No.: 19026 (Parcel 5).

The survey plan referred to in this notice may be viewed at Property Services Department, VIC ROADS, 4th Floor, Materials Building, 60 Denmark Street, Kew.

Published with the authority of the Roads Corporation and the Minister for Roads and Ports.

T. H. HOLDEN
Manager, Property Services
Roads Corporation

**Land Acquisition and Compensation
Act 1986**

Transport Act 1983

NOTICE OF ACQUISITION

Compulsory Acquisition of Interest in Land

The Roads Corporation declares that by this notice it acquires the following interests in the land described hereunder:

Owners' Names: Mr C. and Mrs M. Zambiasi.

Description of Land: Part of Lot 39 on Plan of Subdivision No. 13173, Parish of Bulleen.

Area: 67 square metres.

G 25 29 June 1995 1611

Title Details: Certificate of Title Volume 7608 Folio 195.

Survey Plan No.: 19026 (Parcel 7).

The survey plan referred to in this notice may be viewed at Property Services Department, VIC ROADS, 4th Floor, Materials Building, 60 Denmark Street, Kew.

Published with the authority of the Roads Corporation and the Minister for Roads and Ports.

T. H. HOLDEN
Manager, Property Services
Roads Corporation

**Land Acquisition and Compensation
Act 1986**

Transport Act 1983

NOTICE OF ACQUISITION

Compulsory Acquisition of Interest in Land

The Roads Corporation declares that by this notice it acquires the following interests in the land described hereunder:

Owners' Names: Mr B. and Mrs G. Stella.

Description of Land: Part of Lot 38 on Plan of Subdivision No. 13173, Parish of Bulleen.

Area: 70 square metres.

Title Details: Certificate of Title Volume 7113 Folio 456.

Survey Plan No.: 19026 (Parcel 6).

The survey plan referred to in this notice may be viewed at Property Services Department, VIC ROADS, 4th Floor, Materials Building, 60 Denmark Street, Kew.

Published with the authority of the Roads Corporation and the Minister for Roads and Ports.

T. H. HOLDEN
Manager, Property Services
Roads Corporation

**Land Acquisition and Compensation
Act 1986**

Transport Act 1983

NOTICE OF ACQUISITION

Compulsory Acquisition of Interest in Land

The Roads Corporation declares that by this notice it acquires the following interest in the land described hereunder:

Owners Name: Mr Brian Maurice Fitzgerald and Mrs Eileen Edna Mundy.

1612 G 25 29 June 1995

Description of Interest in Land: Being part of Lot 1 on Plan of Subdivision No. 314693P in the Parish of Buttlejorrk.

Area: 13.204 hectares.

Title Details: Land Contained in Certificate of Title Volume 10099 Folio 505.

Survey Plan No.: 18139C (Parcel 3, 5 and 6).

The survey plan referred to in this notice may be viewed at Property Services, VicRoads, 60 Denmark Street, Kew.

Published with the authority of the Roads Corporation and the Minister for Roads and Ports.

T. H. HOLDEN
Manager, Property Services
Roads Corporation

**Land Acquisition and Compensation
Act 1986**

Transport Act 1983

NOTICE OF ACQUISITION

Compulsory Acquisition of Interest in Land

The Roads Corporation declares that by this notice it acquires the following interest in the land described hereunder:

Owners Name: Donkenzie Investments Pty Ltd.

Description of Interest in Land: Being part of Lot 1 on Plan of Subdivision No. 314694M, Parish of Buttlejorrk.

Area: 2.967 hectares.

Title Details: Part of the land contained in Certificate of Title Volume 10095 Folio 626.

Survey Plan No.: 18142B (Parcels 3 and 8).

The survey plan referred to in this notice may be viewed at Property Services, VicRoads, 60 Denmark Street, Kew.

Published with the authority of the Roads Corporation and the Minister for Roads and Ports.

T. H. HOLDEN
Manager, Property Services
Roads Corporation

**Land Acquisition and Compensation
Act 1986**

Transport Act 1983

NOTICE OF ACQUISITION

Compulsory Acquisition of Interest in Land

The Roads Corporation declares that by this notice it acquires the following interest in the land described hereunder:

Victoria Government Gazette

Owners Name: Mr Ivan Louis Mackie and Mrs Sandra Mackie.

Description of Interest in Land: Being part of Lot 2 and part of lots 1 and 3 on Plan of Subdivision No. 3096 and being part of Crown Portion 205 in the Parish of Prahran.

Area: 120 square metres.

Title Details: Land Contained in Certificate of Title Volume 5140 Folio 834.

Survey Plan No.: 19031A (Parcel 1).

The survey plan referred to in this notice may be viewed at Property Services, VicRoads, 60 Denmark Street, Kew.

Published with the authority of the Roads Corporation and the Minister for Roads and Ports.

T. H. HOLDEN
Manager, Property Services
Roads Corporation

**Land Acquisition and Compensation
Act 1986**

Transport Act 1983

NOTICE OF ACQUISITION

Compulsory Acquisition of Interest in Land

The Roads Corporation declares that by this notice it acquires the following interest in the land described hereunder:

Owners Name: F. B. and M. J. Purcell.

Description of Interest in Land: Being part of Lot 11 on Plan of Subdivision No. 142474, Parish of Buttlejorrk.

Area: 1.502 hectares.

Title Details: Part of the land contained in Certificate of Title Volume 9512 Folio 753.

Survey Plan No.: 18141C (Parcel 1).

The survey plan referred to in this notice may be viewed at Property Services, VicRoads, 60 Denmark Street, Kew.

Published with the authority of the Roads Corporation and the Minister for Roads and Ports.

T. H. HOLDEN
Manager, Property Services
Roads Corporation

**Land Acquisition and Compensation
Act 1986**

Transport Act 1983

NOTICE OF ACQUISITION

Compulsory Acquisition of Interest in Land

The Roads Corporation declares that by this notice it acquires the following interest in the land described hereunder:

Owners Name: D. J. and D. N. Paull.

Description of Interest in Land: Being part of Lot 12 on Plan of Subdivision No. 142474, Parish of Buttlejorrk.

Area: 7.204 hectares.

Title Details: Part of the land contained in Certificate of Title Volume 9512 Folio 754.

Survey Plan No.: 18140B (Parcels 1, 4 and 5).

The survey plan referred to in this notice may be viewed at Property Services, VicRoads, 60 Denmark Street, Kew.

Published with the authority of the Roads Corporation and the Minister for Roads and Ports.

T. H. HOLDEN
Manager, Property Services
Roads Corporation

Creditor, next of kin and others having claims against the estate of any of the undermentioned deceased persons are required to send particulars of their claims to State Trustees Limited A.C.N. 064 593 148, 168 Exhibition Street, Melbourne, Victoria 3000 the personal representative, on or before 1 September 1995, after which date State Trustees Limited may convey or distribute the assets having regard only to the claims of which State Trustees Limited then has notice.

Bowling, Urban Colin in the will called Colin Bowling, late of 11 Swansea Road, Montrose, retired, died on 26 September 1994.

Burke, James, late of 3 Fuller Avenue, Glen Iris, retired, died on 23 May 1994.

Cantwell, Leo James, late of St Marks Private Nursing Home, 829 Mt Alexander Road, Moonee Ponds, pensioner, died on 18 February 1995.

Chapman, Sidney George, late of Centennial Private Nursing Home, Raleigh Street, Prahran, pensioner, died on 8 March 1995.

Cribb, Jean Elizabeth, late of Strathdon Nursing Home, 9 Jolimont Road, Forest Hill, widow, died on 22 May 1995.

Dahlberg, Merna Alice, late of Hollydale Lodge, 37 Burke Road, East Malvern, pensioner, died on 17 May 1995.

Johnstone, John Thomas, late of Centennial House Nursing Home, Windsor, pensioner, died on 29 November 1994.

Lynch, Margaret Beatrice, late of 16 Kooringa Court, Rosebud, widow, died on 11 January 1995.

Mackay, Eunice Jean, late of 184 Melbourne Avenue, Glenroy, pensioner, died on 14 January 1995.

O'Donnell, Bryan Thomas Cullen Patrick, late of 4 Patterson Avenue, Keilor, retired, died on 9 October 1994.

Paterson, Ronald Frederick, late of 12 Hanslope Avenue, Alphington, pensioner, died on 22 February 1995.

Peters, Dorothy Enid, late of 6 Fairlie Avenue, Macleod, widow, died on 17 March 1995.

Rank, Bernard Joseph, late of 17 Macedon Avenue, North Balwyn, retired, died on 22 September 1994.

Rofe, Eric, late of 21 Glenleith Avenue, North Geelong, pensioner, died on 10 February 1995.

Rowe, Horace Harrison, late of 27 Hunter Street, Malvern, retired, died on 6 March 1995.

Shaw, Baiba Karina, late of 7 Clonmult Avenue, Highett, pensioner, died on 30 March 1995.

Supernak, Peter, late of 171 Inglis Street, Ballan, gentleman, died on 25 December 1994.

Trewern, William Florence, late of Darlingford Upper Goulburn Nursing Home, Eildon Road, Eildon, retired, died on 16 June 1994.

Dated at Melbourne on 23 June 1995

B. F. CARMODY
Managing Director

Petroleum (Submerged Lands) Act 1967
COMMONWEALTH OF AUSTRALIA
Release of Information under Section 118 (5A)

I, Sidney James Plowman, the Minister for Energy and Minerals, the Designated Authority in respect of the area specified as being adjacent to the State of Victoria, under Section 118 (5B) of the **Petroleum (Submerged Lands) Act 1967** of the Commonwealth of Australia—

- (a) notify that I propose to make the information specified in the following Schedule available or publicly known;
- (b) invite interested persons to give to me, within forty-five (45) days after the publication of this Notice in the Gazette, a notice objecting to the whole or any part of the information being made available or publicly known; and

- (c) notify that if a person does not make an objection in accordance with this invitation, the person will be taken to have consented to the information being made available or publicly known.

Note: As required by the Act:

1. There shall be set out in the notice of objection the reasons for making the objection.

2. A person is not entitled to make an objection to information being made available or publicly known except on the grounds that to do so would disclose—

- (a) a trade secret; or
- (b) any other information the disclosure of which would, or could reasonably be expected to adversely affect the person in respect of the lawful business, commercial or financial affairs of the person.

SCHEDULE

All information that was furnished to the Designated Authority prior to 1 July 1990 including information contained in documents, being information that relates to the sea-bed or subsoil, or to petroleum, in a block, and that in the opinion of the Designated Authority is a conclusion drawn, in whole or in part, or any information contained in documents to which section 118 of the **Petroleum (Submerged Lands) Act 1967** applies.

Dated 23 June 1995

SIDNEY JAMES PLOWMAN
Designated Authority

Petroleum (Submerged Lands) Act 1967 COMMONWEALTH OF AUSTRALIA Section 71

Instrument of Variation—VIC/PL25

I, Sidney James Plowman, Minister for Energy and Minerals for the State of Victoria, the Designated Authority in respect of the area specified as being adjacent to the State of Victoria, acting for and on behalf of the Commonwealth—Victoria Offshore Petroleum Joint Authority, at the request of Esso Australia Resources Ltd and BHP Petroleum (Bass Strait) Pty Ltd, hereby vary pursuant to the provisions of Section 71 (5) of the **Petroleum (Submerged Lands) Act 1967**, Pipeline Licence No. VIC/PL25 in the manner indicated in the Schedule hereto:

Victoria Government Gazette

1. Delete “conveyance of gaseous hydrocarbons” where occurring on page 1 of the pipeline Licence and substitute “conveyance of gaseous and liquid hydrocarbons”.
2. Delete “conveyance of gaseous hydrocarbons” from Clause 1 (A) (ii) (a) of the Second Schedule and substitute “conveyance of gaseous and liquid hydrocarbons”.
3. Delete “a flow rate of 860 kilo cubic metres per day of gaseous hydrocarbons” from Clause 1 (A) (ii) (b) of the Second Schedule and substitute “a flow rate of 3500 kilolitres per day of gaseous and liquid hydrocarbons”.

Dated at Melbourne 22 June 1995.

Made under the **Petroleum (Submerged Lands) Act 1967** of the Commonwealth of Australia.

SIDNEY JAMES PLOWMAN
Designated Authority

VICTORIAN CASINO AND GAMING AUTHORITY

Substitution of Schedule 1 to the Notice of Approval for Casino Games which was published in the Government Gazette on 30 March 1995.

Pursuant to section 60 (1) of the **Casino Control Act 1991**, the Victorian Casino and Gaming Authority on 7 June 1995, resolved to substitute Schedule 1 to the Notice of Approval for Casino Games which was published in the Government Gazette on 30 March 1995.

SCHEDULE ONE ARISTOCRAT

Game 001AST Antony and Cleopatra
Game 002AST Arabian Nights
Game 003AST Arctic Wins
Game 004AST Chain Reaction
Game 005AST Countdown
Game 006AST Desert Gold
Game 007AST Diamonds and Pearls
Game 008AST Dinomight
Game 009AST Dollar Action
Game 010AST Dollarado
Game 011AST Emerald City
Game 012AST Extra 2 Ball Bingo
Game 013AST Fever Pitch

Game 014AST Free Throw
Game 015AST Guns & Roses
Game 016AST High Stakes
Game 017AST Idol Riches
Game 018AST It's Time
Game 019AST KG Bird
Game 020AST Love and Marriage
Game 021AST Lucky Bug
Game 022AST Lucky Strike
Game 023AST Nine Lives
Game 024AST Oasis
Game 025AST Panda
Game 026AST Rebel Yell
Game 027AST Samurai
Game 028AST Superbucks
Game 029AST Surf, Sun, Fun
Game 030AST Tequila Sunrise
Game 031AST The Wild
Game 032AST Top Gear
Game 033AST Treasure
Game 034AST Trick or Treat
Game 035AST White Tiger
Game 036AST Win Mills
Game 037AST Winning Streak
Game 038AST Money or the Box
Game 039AST Double Agent
Game 040AST Enchanted Forest
Game 041AST Fortune Hunter
Game 042AST Three Bags Full

IGT

Game 001IGT 8, 9, 10, Spot Progressive
Keno

Game 002IGT Blast Off
Game 003IGT Blazing Bucks
Game 004IGT Deuces Wild
Game 005IGT Double Dollars
Game 006IGT Double Fortune
Game 007IGT Double Strike
Game 008IGT Draw Poker
Game 009IGT Flash Cash
Game 010IGT Free for All
Game 011IGT Galaxy
Game 012IGT Hit The Spot Keno
Game 013IGT Hollywood
Game 014IGT Jackpot Jewels
Game 015IGT Joker Wild Poker
Game 016IGT Little Angel
Game 017IGT Locomotion
Game 018IGT Mardi Gras

Game 019IGT Progressive Draw Poker
Game 020IGT Red, White & Blue
Game 021IGT Spellbound
Game 022IGT Splash Out
Game 023IGT Star Studded
Game 024IGT Super 8 Spot Keno
Game 025IGT Treasure Trove
Game 026IGT Triple Diamond
Game 027IGT Triple Gold
Game 028IGT Triple Scoop
Game 029IGT White Lightning
Game 030IGT Wild Eagle
Game 031IGT Aztec Riches
Game 032IGT Black Rhino
Game 033IGT Blue Moon
Game 034IGT Coral Reef
Game 035IGT Lion Dance
Game 036IGT Mystical Orient
Game 037IGT Pure Pleasure
Game 038IGT Tidal Wave

VLC

Game 001VLC Blackjack
Game 002VLC Deuces Wild
Game 003VLC Double Eagle
Game 004VLC Draw Poker
Game 005VLC Flush Fever
Game 006VLC High Fever
Game 007VLC Jackpot Poker
Game 008VLC Jacks or Better
Game 009VLC Joker Poker
Game 010VLC Keno
Game 011VLC Keno Wild
Game 012VLC Power Keno
Game 013VLC Red Hot 7's
Game 014VLC Ring'em Up
Game 015VLC Second Chance

OLYMPIC

Game 001OLY Aces & Kings
Game 002OLY African Warrior
Game 003OLY Martians
Game 004OLY Merlin's Magic
Game 005OLY On A Roll
Game 006OLY The Cat & The Fiddle
Game 007OLY Treasure Trail
Game 008OLY Wild Card
Game 009OLY Boomtown
Game 010OLY Stake Your Claim
Game 011OLY Jolly Roger

1616 G 25 29 June 1995

VIDCO

Game 001VID Funny Farm
Game 002VID Pluck A Buck
Game 003VID Big Bikkies
Game 004VID Mumbo Jumbo
Game 005VID Ants Pants
Game 006VID Hokie Pokie
Game 007VID Money Spinner

**Education Act 1958
AMENDMENT TO SCHOOL COUNCIL
CONSTITUTING ORDERS**

Pursuant to section 13 (4) of the **Education Act 1958**, I give notice that an Order of the Governor in Council was made on 14 June 1995 to amend the Constituting Orders of the School Council of the listed schools in respect of the membership of those school councils.

Bullengarook Primary School
Courtenay Gardens Primary School
Foster Consolidated School
Preston Special Developmental School
Tanjil South Primary School
Woodford Primary School
Yellingbo Primary School

DON HAYWARD
Minister for Education

**Electricity Industry Act 1993
NOTICE OF GRANT OF LICENCES**

Pursuant to section 165 of the **Electricity Industry Act 1993**, (the Act). The Office of the Regulator-General gives notice that it has this day issued the following licences pursuant to section 162 of the Act.

- To Electricity Australia Pty Limited (ACN 069 511 655)—a licence to sell electricity.
- To Energy Brix Australian Corporation—a licence to generate electricity.

The above licences have an unlimited term but may be revoked or varied as provided by the Act or by the terms of the relevant licence.

A copy of the above licences may be inspected during business hours at the Office of the Regulator-General, 1st Floor, 35 Spring Street, Melbourne 3000.

Dated 23 June 1995

Victoria Government Gazette

**EXEMPTION FROM NOTIFICATION OF
VACANCY UNDER SECTION 29 (2) OF
THE PUBLIC SECTOR MANAGEMENT
ACT 1992**

Position No. 30/04/0045/2, Administrative Officer, Class AM-3, Community Health and Support Branch, Primary Care Division, Department of Health and Community Services.

Reasons for exemption

The position has identical duties and qualifications to a position that was recently advertised and the person was an applicant for the vacancy and was assessed as meeting the requirements of the position.

(Dr) JOHN PATERSON
Secretary, Health and Community Services

**EXEMPTION FROM NOTIFICATION OF
VACANCY UNDER SECTION 29 (2) OF
THE PUBLIC SECTOR MANAGEMENT
ACT 1992**

Position No. 30/01/0419/8, Senior Project Officer, Administrative Officer, Class AM-7, Office of the Secretary, Department of Health and Community Services.

Reasons for exemption

The vacancy has duties and qualifications that are of a specialised nature peculiar to the department and the appointee is a staff member considered to be the only staff member possessing the specialised qualifications.

(Dr) JOHN PATERSON
Secretary, Health and Community Services

ORDERS IN COUNCIL

**Crown Land (Reserves) Act 1978
CROWN LANDS TEMPORARILY RESERVED**

The Governor in Council under section 4 of the Crown Land (Reserves) Act 1978 temporarily reserves the following Crown lands for the purposes mentioned:

MUNICIPAL DISTRICT OF THE SHIRE OF COLAC-OTWAY

APOLLO BAY—Public purposes, 19 hectares, more or less, being Crown Allotment 23, Section 2, Township of Apollo Bay, Parish of Krambruk as indicated by hatching on plan hereunder—(A 193[2]) (94/1172).

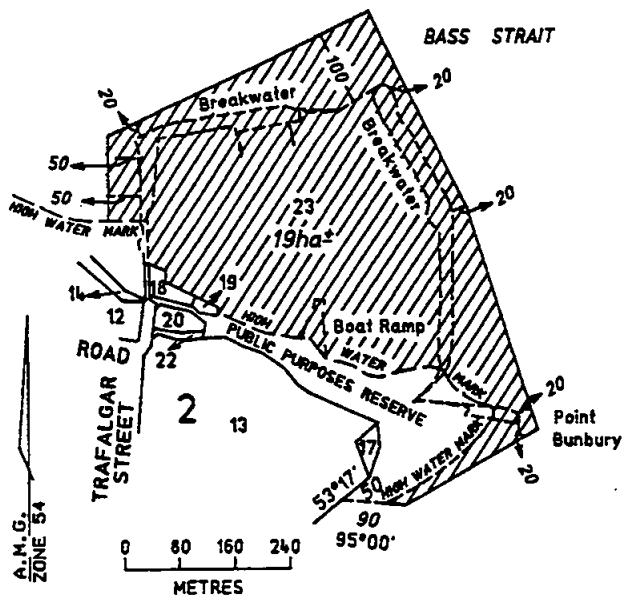

MUNICIPAL DISTRICT OF THE CITY OF GREATER GEELONG

BARWON HEADS and CONEWARRE—Public purposes, 28 hectares, more or less, being Crown Allotment 18, Section B, Township of Barwon Heads and Crown Allotments 17 and 18, Parish of Conewarre as indicated by hatching on plan hereunder—(2421, B 797[1]) (07/4538).

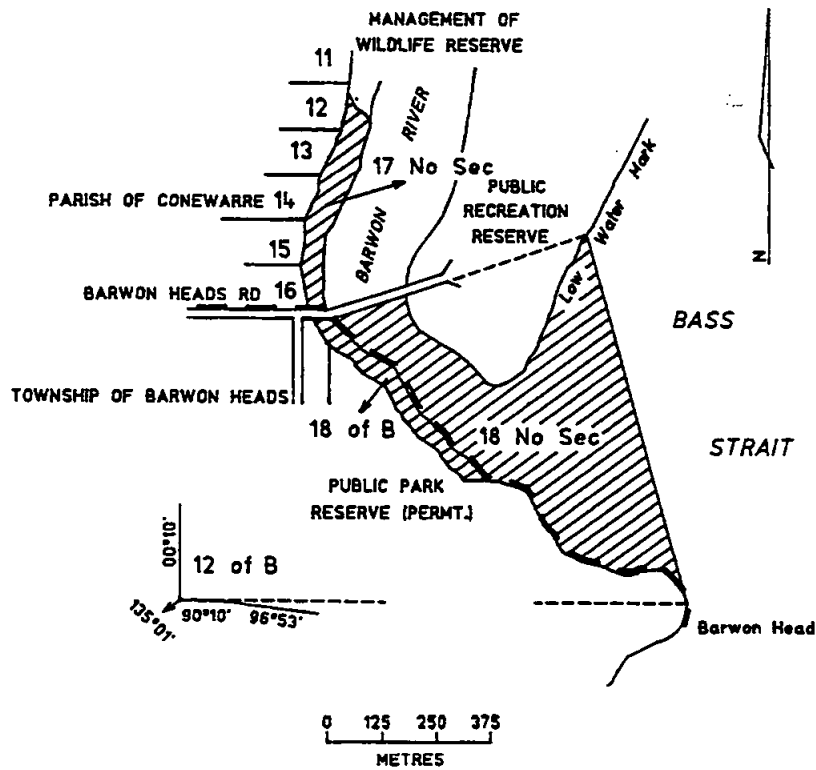

Total area of hatched portions 28ha[±]

MUNICIPAL DISTRICT OF THE SHIRE OF MOYNE

BELFAST—Public purposes—

- (a) 931 square metres being Crown Allotments 7W and 7X, Parish of Belfast as shown on Certified Plan No. 108590 lodged in the Central Plan Office; and
- (b) 900 square metres, more or less, being Crown Allotment 7X4, Parish of Belfast as indicated by hatching on plan hereunder—(2105) (L2/4474).

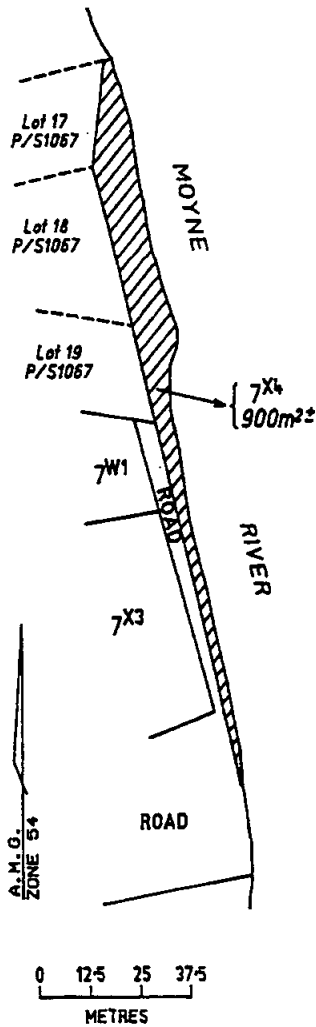

MUNICIPAL DISTRICT OF THE SHIRE OF EAST GIPPSLAND

COLQUHOUN—Public purposes, 7336 square metres being Crown Allotment 84U, Parish of Colquhoun as indicated by hatching on plan hereunder—(C 383[10]) (16/4354).

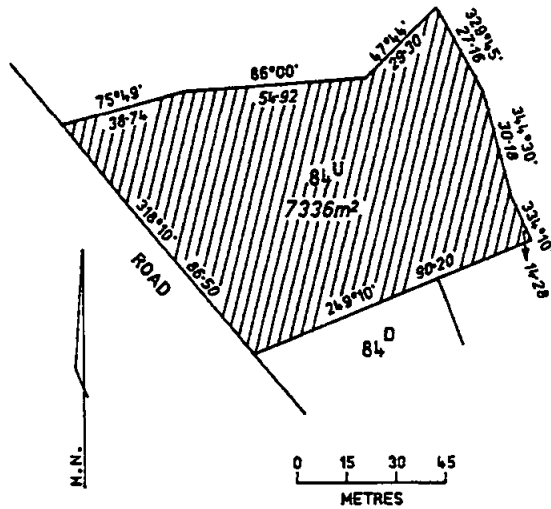

MUNICIPAL DISTRICT OF THE SHIRE OF BASS COAST

CORINELLA—Public purposes, 1.04 hectares, more or less, being Crown Allotment 14E, Township of Corinella, Parish of Corinella as indicated by hatching on plan hereunder—(C 246[8]) (Rs 37085).

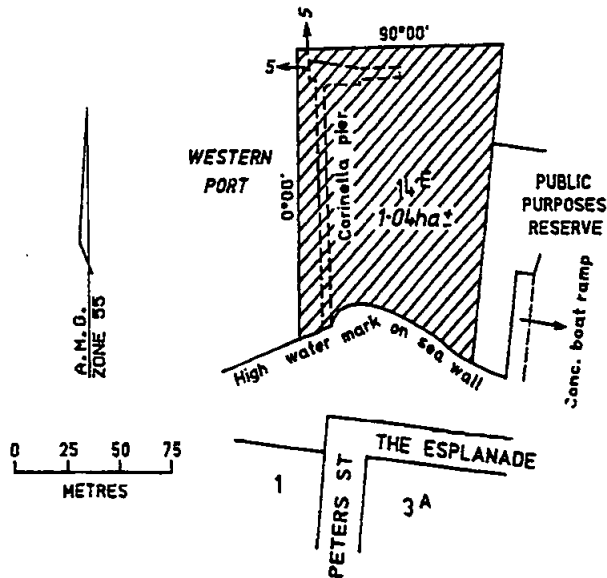

MUNICIPAL DISTRICT OF THE SHIRE OF BASS COAST

COWES—Public purposes, 2700 square metres, more or less, being Crown Allotment 23, Section 4, Township of Cowes, Parish of Phillip Island as indicated by hatching on plan hereunder—(C 443[4]) (Rs 37086).

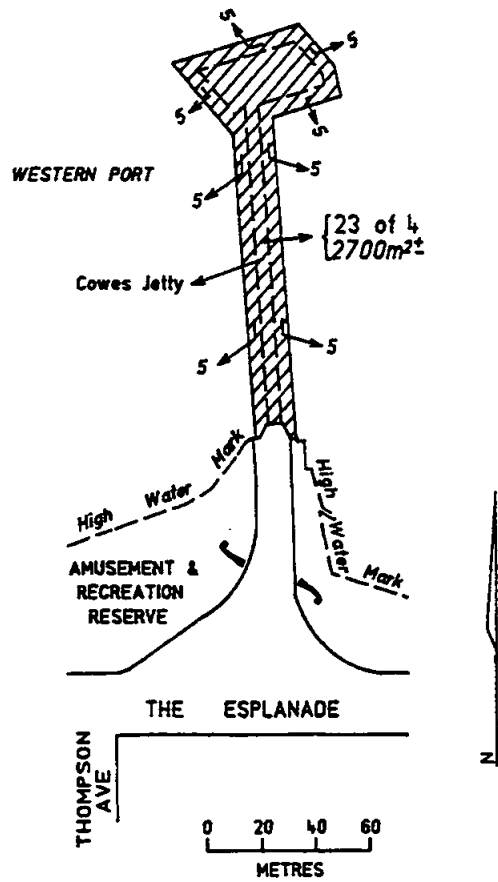

MUNICIPAL DISTRICT OF THE SHIRE OF MORNINGTON PENINSULA

FLINDERS—Public purposes, 5400 square metres, more or less, being Crown Allotment 16B, Township of Flinders, Parish of Flinders as indicated by hatching on plan hereunder—(F16[A1]) (Rs 37082).

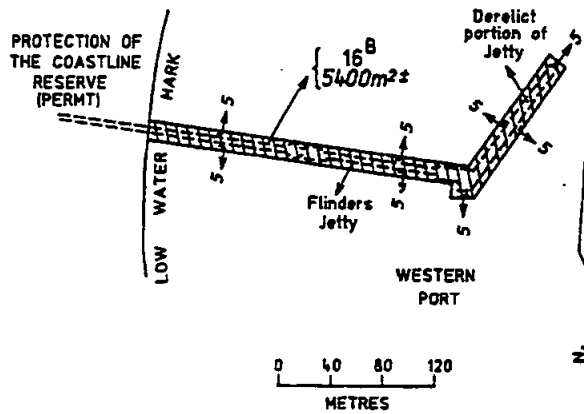

MUNICIPAL DISTRICT OF THE CITY OF FRANKSTON

FRANKSTON—Public purposes, 1700 square metres, more or less, being Crown Allotment 11B, Section A, Parish of Frankston as indicated by hatching on plan hereunder—(F87[5]) (Rs 37076).

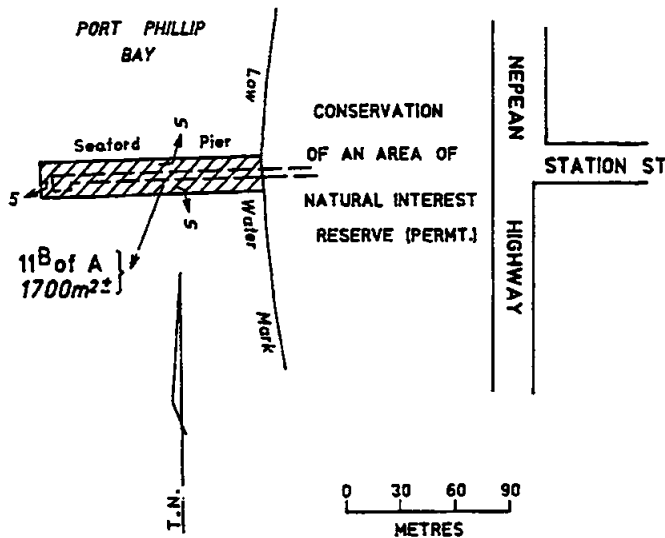

MUNICIPAL DISTRICT OF THE CITY OF FRANKSTON

FRANKSTON—Public purposes, 4350 square metres, more or less, being Crown Allotment 1B, Section 7, Township of Frankston, Parish of Frankston as indicated by hatching on plan hereunder—(F 86[4]) (Rs 37077).

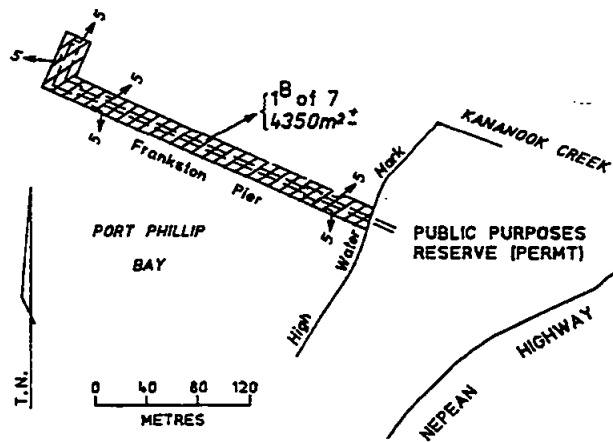

NOT WITHIN A MUNICIPAL DISTRICT

FRENCH ISLAND—Public purposes, 4 hectares, more or less, being Crown Allotment 3A3, Parish of French Island as indicated by hatching on plan hereunder—(F 97[10]) (Rs 37094).

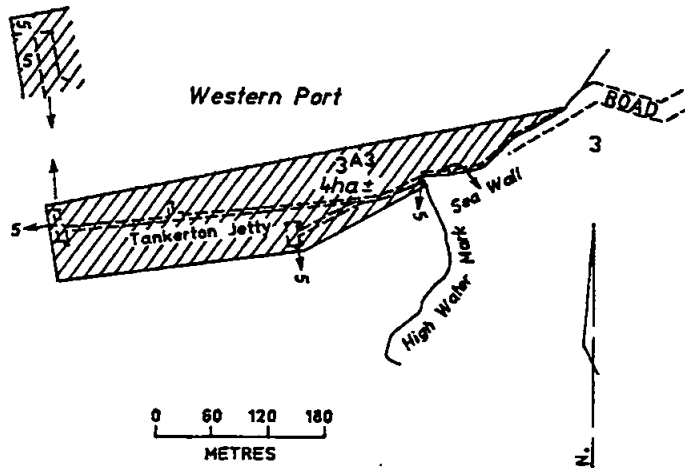

MUNICIPAL DISTRICT OF THE SHIRE OF MORNINGTON PENINSULA

HASTINGS—Public purposes, 2.3 hectares, more or less, being Crown Allotment 24, Section D, Township of Hastings, Parish of Tyabb as indicated by hatching on plan hereunder—(H 122[2]) (Rs 37083).

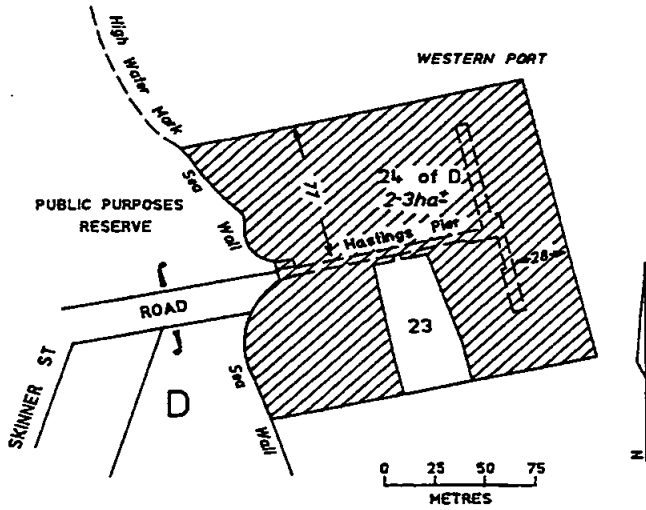

MUNICIPAL DISTRICT OF THE SHIRE OF MORNINGTON PENINSULA

KANGERONG—Public purposes, 2350 square metres, more or less, being Crown Allotment 2H, Section 1, Parish of Kangerong as indicated by hatching on plan hereunder—(K7[4]) (Rs 37078).

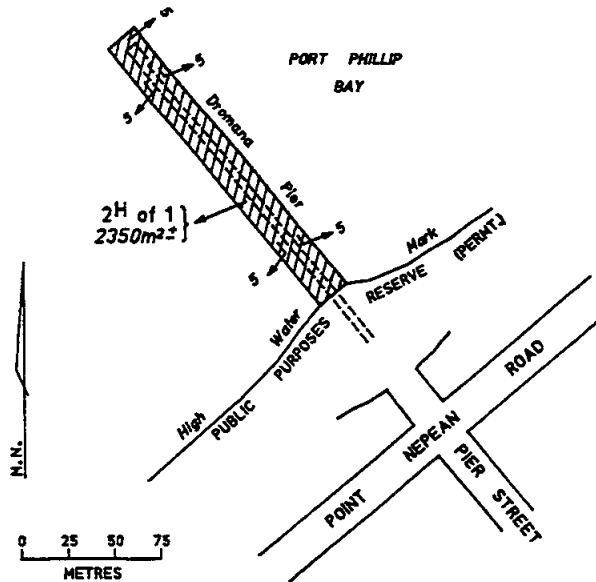

MUNICIPAL DISTRICT OF THE CITY OF CASEY

KOO-WEE-RUP—Public purposes, 480 square metres, more or less, being Crown Allotment 5C, Parish of Koo-wee-rup as indicated by hatching on plan hereunder—(2920-2) (Rs 37084).

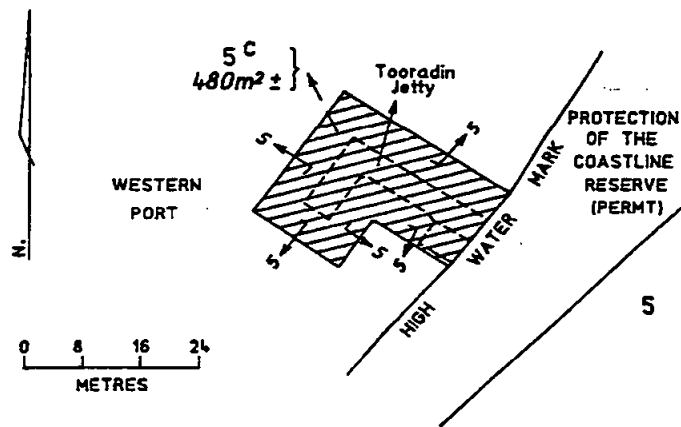

MUNICIPAL DISTRICT OF THE CITY OF CASEY

LANG LANG—Public purposes, 1450 square metres, more or less, being Crown Allotment 24E, Parish of Lang Lang as indicated by hatching on plan hereunder—(2968) (Rs 37080).

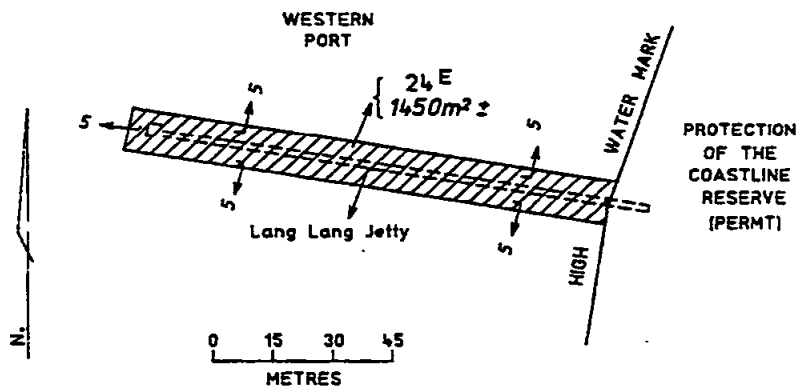

MUNICIPAL DISTRICT OF THE CITY OF KINGSTON

LYNDHURST—Public purposes, 16 hectares, more or less, being Crown Allotment 1A3, Parish of Lyndhurst as indicated by hatching on plan hereunder—(L 101[9]) (Rs 37101).

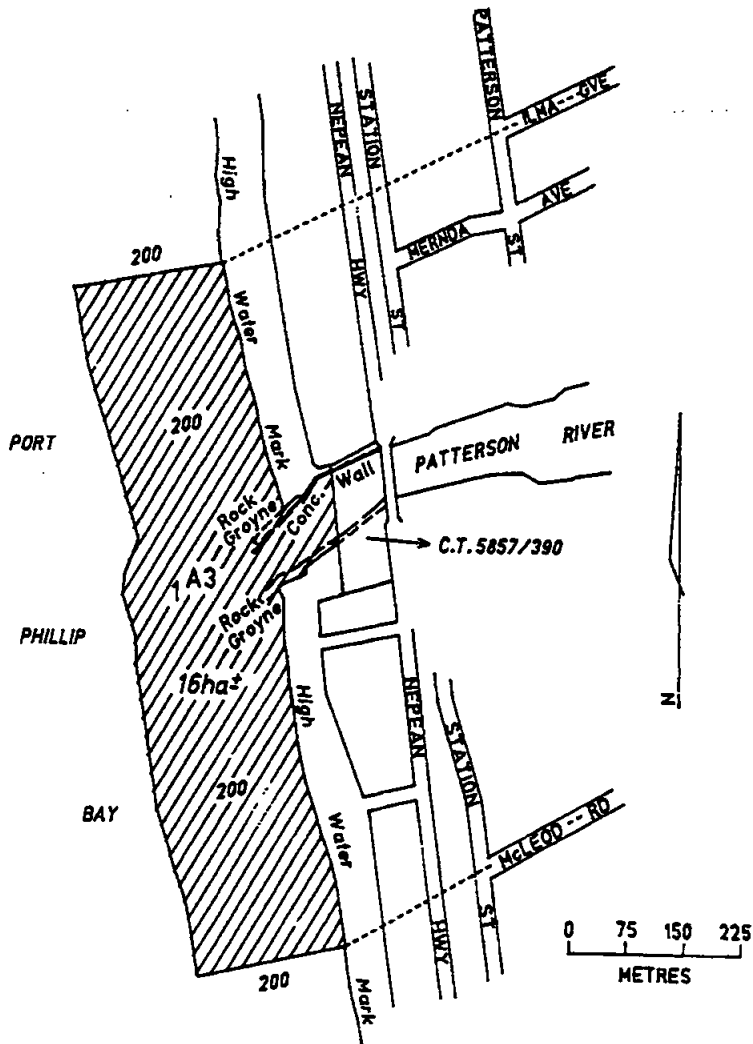

MUNICIPAL DISTRICT OF THE CITY OF KINGSTON

LYNDHURST—Public purposes, 15 hectares, more or less, being Crown Allotment 12A3, Parish of Lyndhurst as indicated by hatching on plan hereunder—(L 101[9]) (Rs 37097).

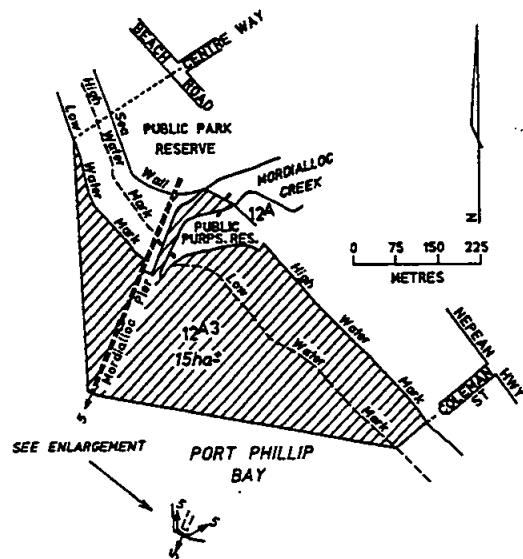

MUNICIPAL DISTRICT OF THE CITY OF BAYSIDE

MOORABBIN—Public purposes, 21 hectares, more or less, being Crown Allotment 1F3, Parish of Moorabbin as indicated by hatching on plan hereunder—(M 164[3]) (Rs 37099).

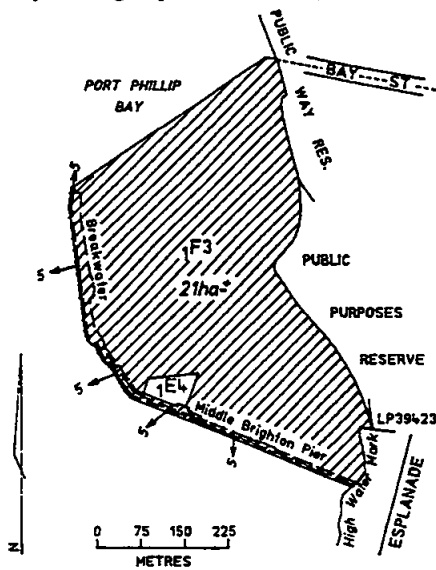

MUNICIPAL DISTRICT OF THE CITY OF BAYSIDE

MOORABBIN—Public purposes, 9.6 hectares, more or less, being Crown Allotments 21H and 21J, Parish of Moorabbin as indicated by hatching on plan hereunder—(M 164[3]) (Rs 37100).

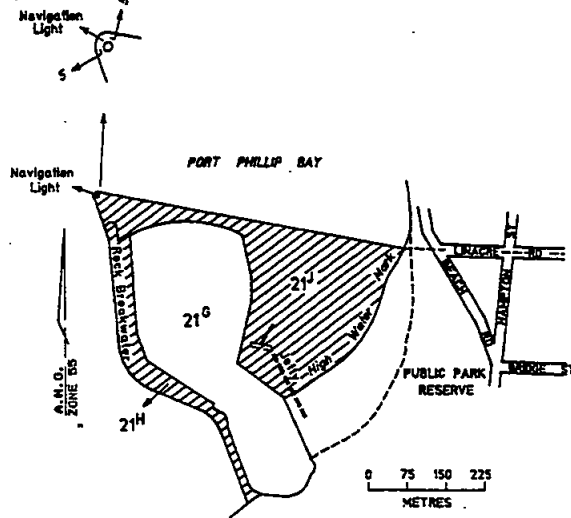

Total area of allotments 21^H and 21^J = 9.6ha²

MUNICIPAL DISTRICT OF THE CITY OF BAYSIDE

MOORABBIN—Public purposes, 1600 square metres, more or less, being Crown Allotment 28B, Parish of Moorabbin as indicated by hatching on plan hereunder—(M 164[3]) (Rs 37075).

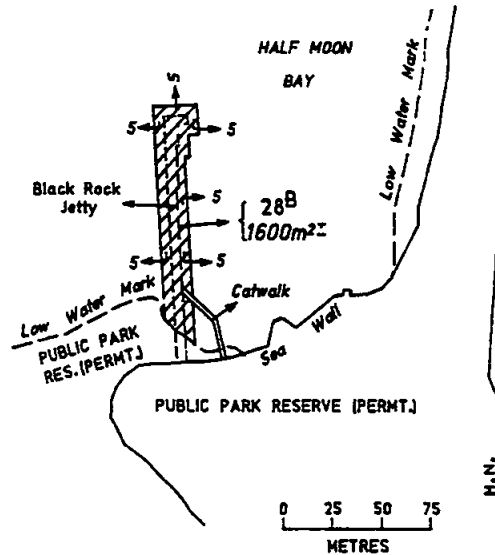

MUNICIPAL DISTRICT OF THE SHIRE OF MORNINGTON PENINSULA

MORNINGTON—Public purposes, 1.8 hectares, more or less, being Crown Allotment 8G, Section 1, Township of Mornington, Parish of Moorooduc as indicated by hatching on plan hereunder—(M 162[2]) (Rs 37087).

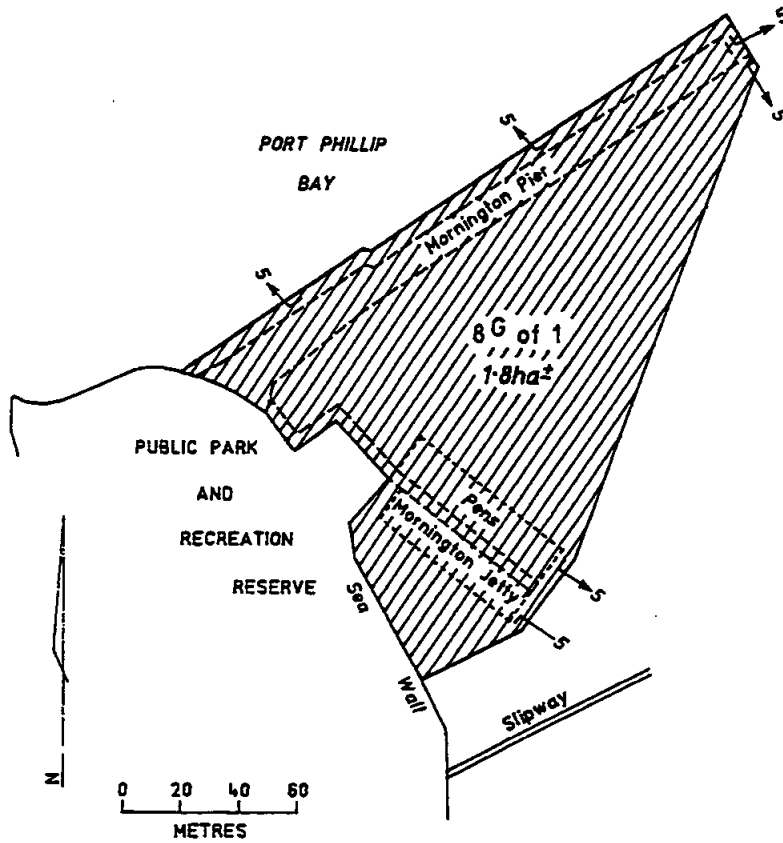

MUNICIPAL DISTRICT OF THE SHIRE OF MORNINGTON PENINSULA

NEPEAN—Public purposes, 3750 square metres, more or less, being Crown Allotment 77F, Parish of Nepean as indicated by hatching on plan hereunder—(N 57[5]) (Rs 37090).

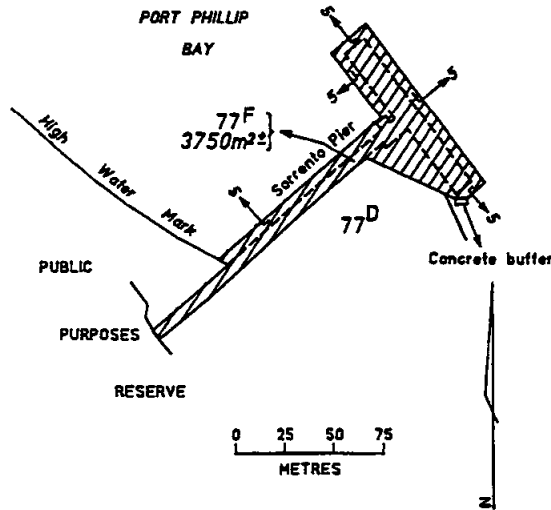

MUNICIPAL DISTRICT OF THE SHIRE OF MORNINGTON PENINSULA

NEPEAN—Public purposes, 3400 square metres, more or less, being Crown Allotment 146B, Parish of Nepean as indicated by hatching on plan hereunder—(N 57[5]) (Rs 37091).

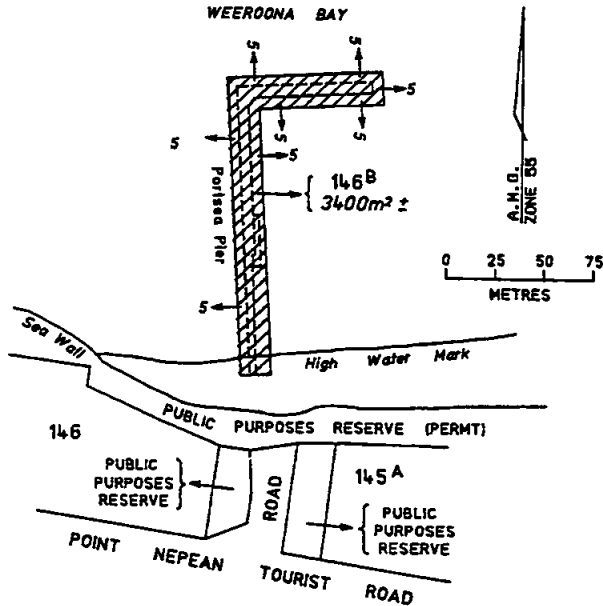

MUNICIPAL DISTRICT OF THE SHIRE OF BASS COAST

NEWHAVEN—Public purposes, 5350 square metres, more or less, being Crown Allotments 1B and 1C, Section 1, Township of Newhaven, Parish of Phillip Island as indicated by hatching on plan hereunder—(N 150[3]) (Rs 37098).

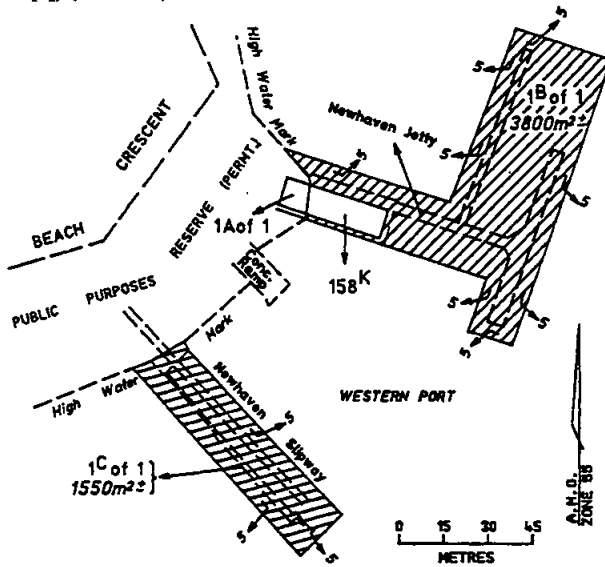

TOTAL AREA OF HATCHED PORTIONS 5350m²

MUNICIPAL DISTRICT OF THE CITY OF GREATER GEELONG

PAYWIT—Public purposes, 220 hectares, more or less, being Crown Allotment 17L, Parish of Paywit as indicated by hatching on plan hereunder—(3380[1]) (07/4540).

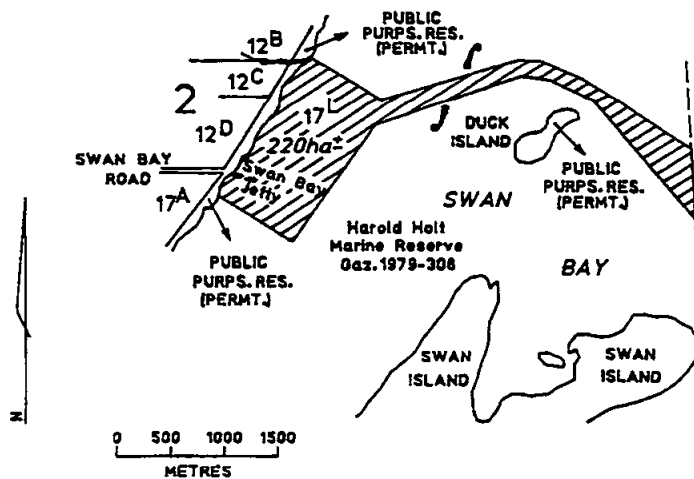

MUNICIPAL DISTRICT OF THE CITY OF GREATER GEELONG

PAYWIT—Public purposes, 1.8 hectares, more or less, being Crown Allotment 45, Section 1, Parish of Paywit as indicated by hatching on plan hereunder—(3380[2]) (07/4527).

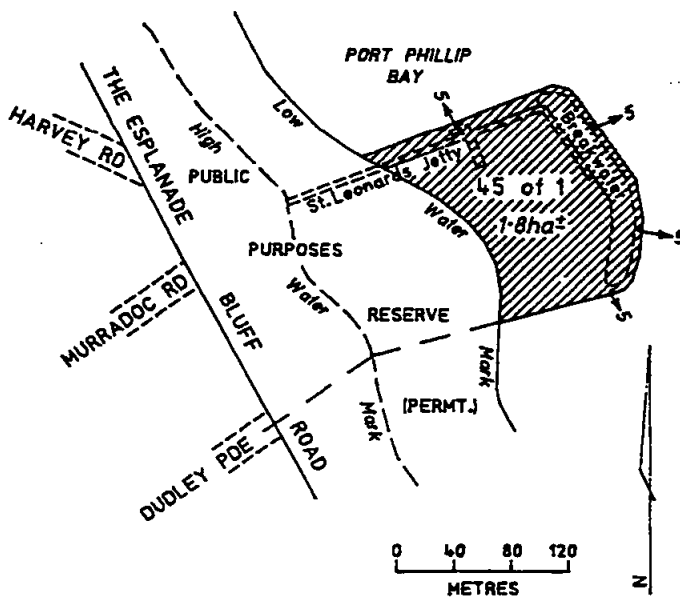

MUNICIPAL DISTRICT OF THE BOROUGH OF QUEENSLIFFE

PAYWIT—Public purposes, 3250 square metres, more or less, being Crown Allotment 4B, Section 5, Parish of Paywit as indicated by hatching on plan hereunder—(3380) (07/4531).

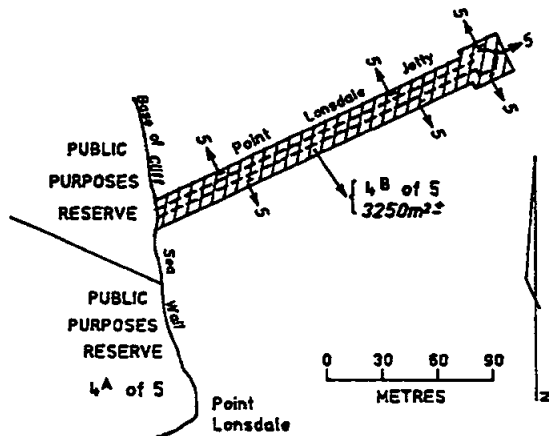

MUNICIPAL DISTRICT OF THE BOROUGH OF QUEENSLIFFE

PAYWIT and QUEENSLIFF—Public purposes, 137 hectares, more or less, being Crown Allotments 1B1 and 1B2, Section 2B, Parish of Paywit and Crown Allotment 8, Section 6A, Township of Queenscliff as indicated by hatching on plan hereunder—(Q 34(5), 3380(1)) (07/4545).

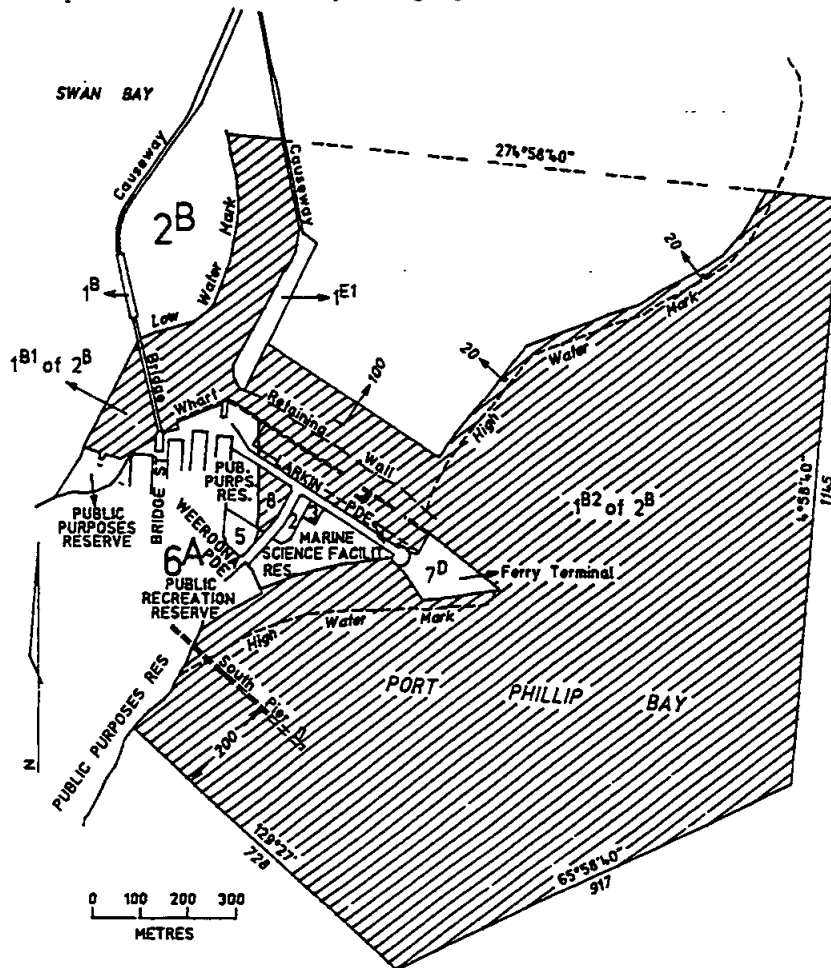

Total area of allotments 8 of 6^A, 1^{B1} & 1^{B2} of 2^B = 137ha²

MUNICIPAL DISTRICT OF THE CITY OF GREATER GEELONG

PORTARLINGTON—Public purposes, 6.5 hectares, more or less, being Crown Allotment 19X, Township of Portarlington, Parish of Bellarine as indicated by hatching on plan hereunder—(P 37(3)) (07/4543).

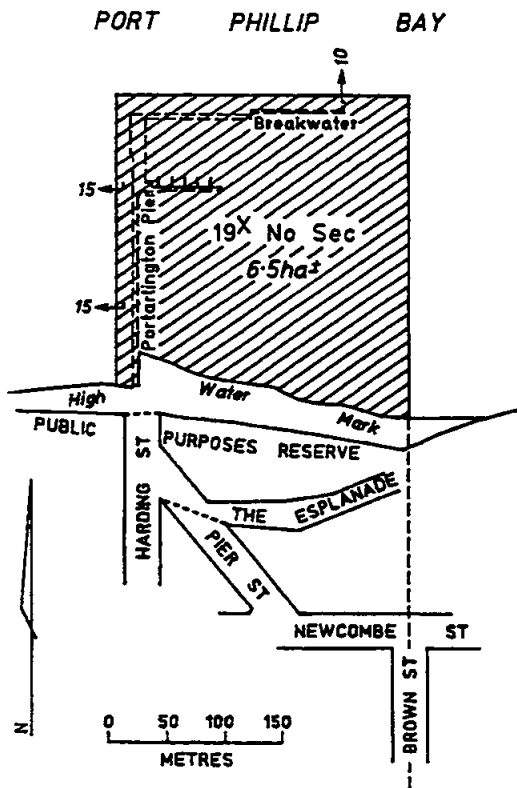

MUNICIPAL DISTRICT OF THE SHIRE OF MORNINGTON PENINSULA

ROSEBUD—Public purposes, 5800 square metres, more or less, being Crown Allotment 33A, Section 1, Township of Rosebud, Parish of Wannaeuc as indicated by hatching on plan hereunder—(W 32[3]) (Rs 37079).

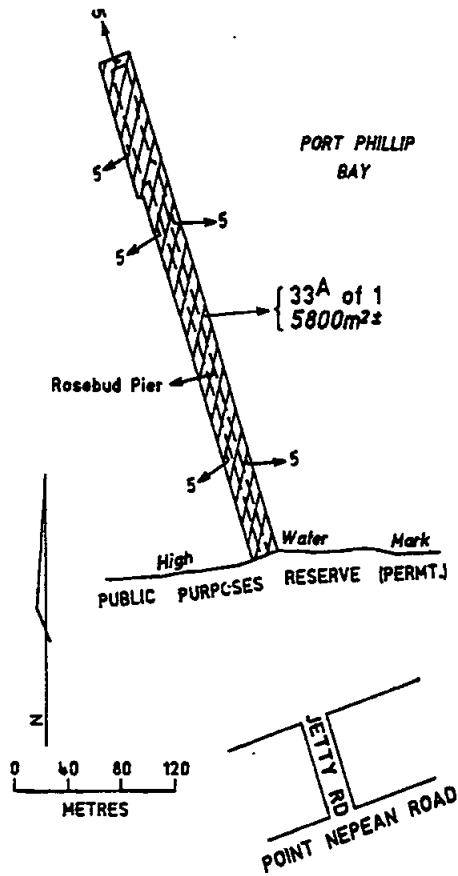

MUNICIPAL DISTRICT OF THE SHIRE OF BASS COAST

RHYLL—Public purposes, 1850 square metres, more or less, being Crown Allotment 6C, Section 5, Township of Rhyll, Parish of Phillip Island as indicated by hatching on plan hereunder—(R 90[1]) (Rs 37089).

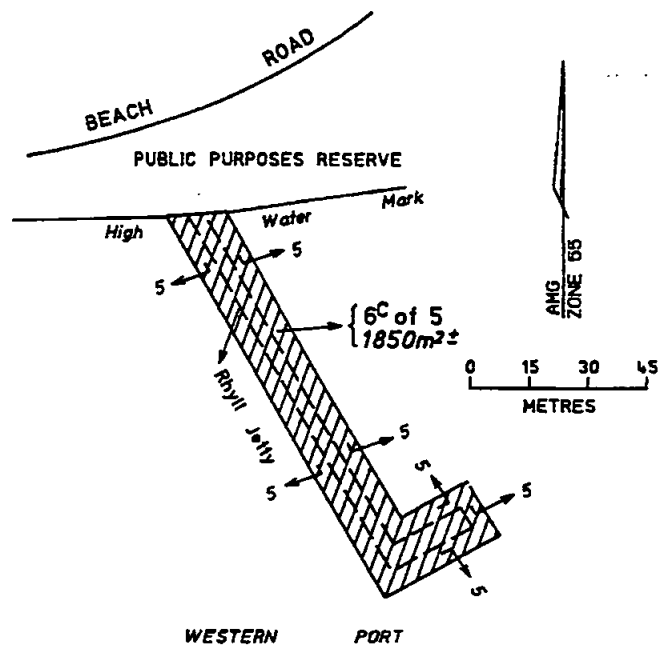

1638 G 25 29 June 1995

Victoria Government Gazette

MUNICIPAL DISTRICT OF THE SHIRE OF MORNINGTON PENINSULA

RYE—Public purposes, 7000 square metres, more or less, being Crown Allotment 4B, Township of Rye, Parish of Nepean as indicated by hatching on plan hereunder—(R48[3]) (Rs 37088).

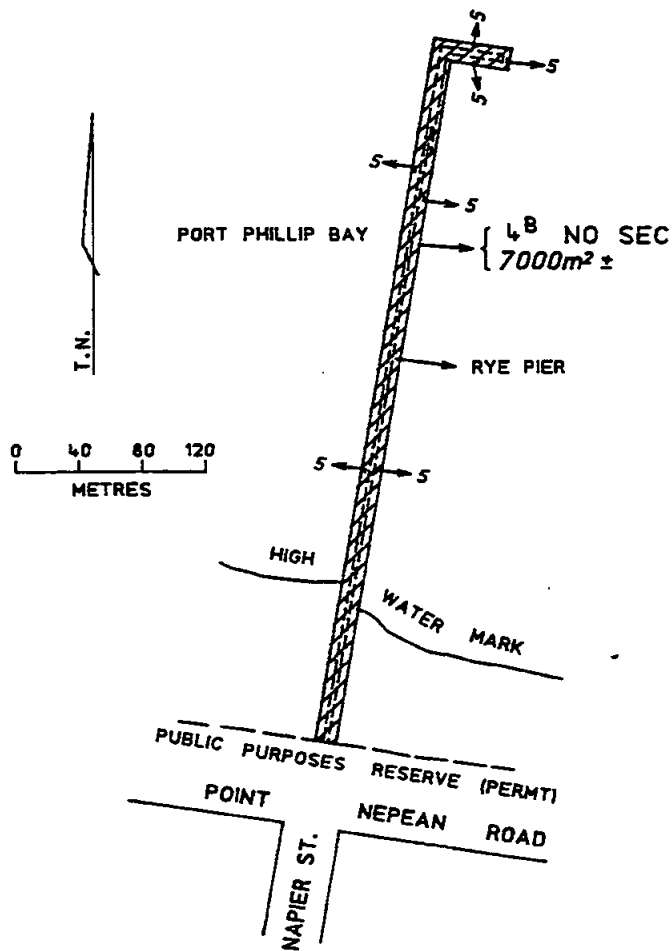

MUNICIPAL DISTRICT OF THE CITY OF PORT PHILLIP

ST. KILDA—Public purposes, 1100 square metres, more or less, being Crown Allotment 90H, at St. Kilda, Parish of Melbourne South as indicated by hatching on plan hereunder—(M 333[25]) (Rs 37081).

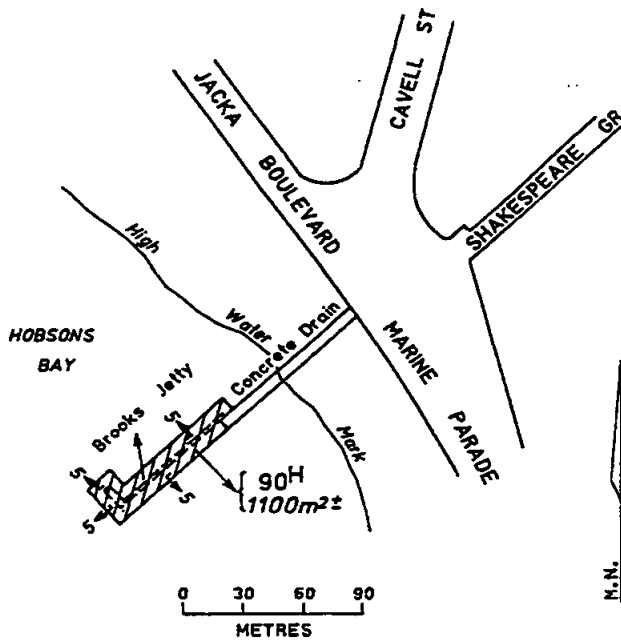

MUNICIPAL DISTRICT OF THE CITY OF PORT PHILLIP

ST. KILDA—Public purposes, 55 hectares, more or less, being Crown Allotment 22, Section 2X at St. Kilda, Parish of Melbourne South as indicated by hatching on plan hereunder—(M 333[27]) (Rs 37096).

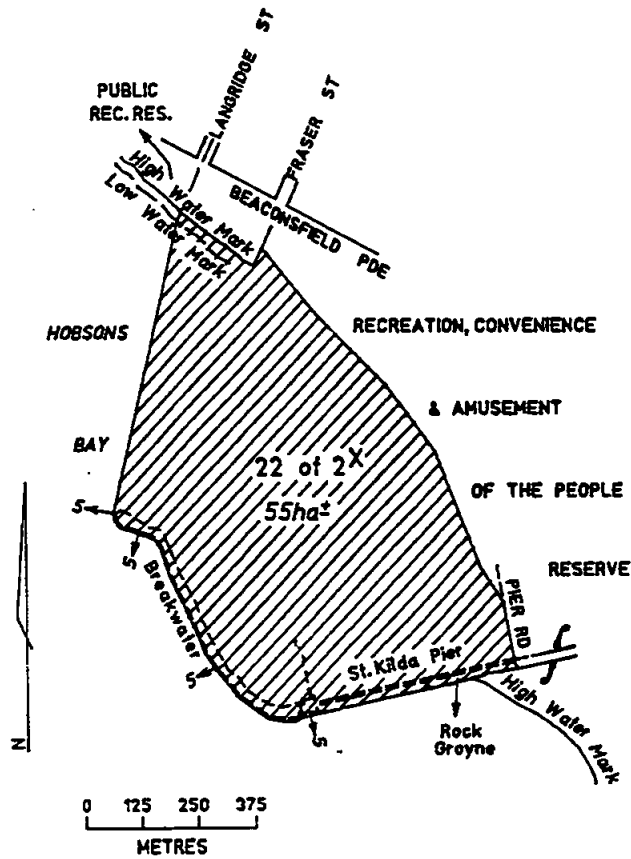

MUNICIPAL DISTRICT OF THE SHIRE OF BASS COAST

SAN REMO—Public purposes, 1.4 hectares, more or less, being Crown Allotment 1M, Section A, Township of San Remo, Parish of Woolamai as indicated by hatching on plan hereunder—(S 436[3]) (Rs 37095).

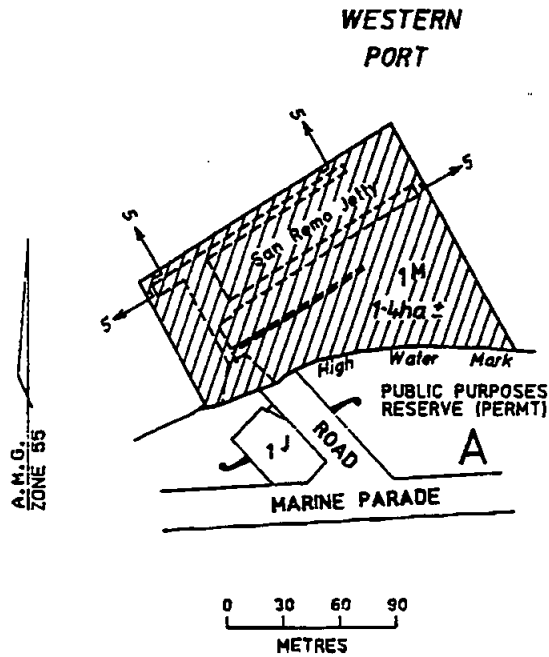

MUNICIPAL DISTRICT OF THE CITY OF HOBSONS BAY

TRUGANINA—Public purposes, 3250 square metres, more or less, being Crown Allotment 2, Section 8, Parish of Truganina as indicated by hatching on plan hereunder—(T 109[6]) (Rs 37074).

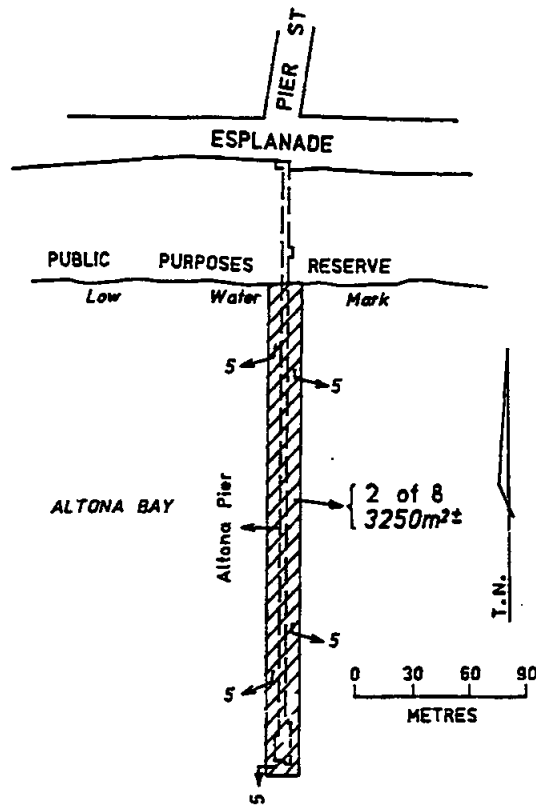

MUNICIPAL DISTRICT OF THE CITY OF CASEY

WARNEET—Public purposes, 2550 square metres, more or less, being Crown Allotment 35, Section A, Township of Warneet, Parish of Sherwood as indicated by hatching on plan hereunder—(W 427[6]) (Rs 37092).

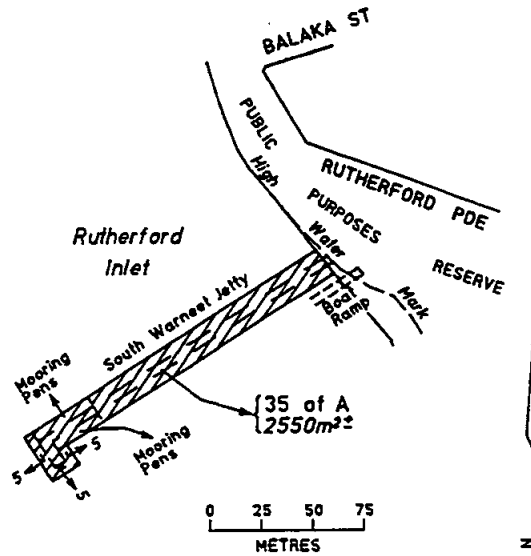

MUNICIPAL DISTRICT OF THE CITY OF CASEY

WARNEET—Public purposes, 1050 square metres, more or less, being Crown Allotment 30, Section B, Township of Warneet, Parish of Sherwood as indicated by hatching on plan hereunder—(W 427[6]) (Rs 37093).

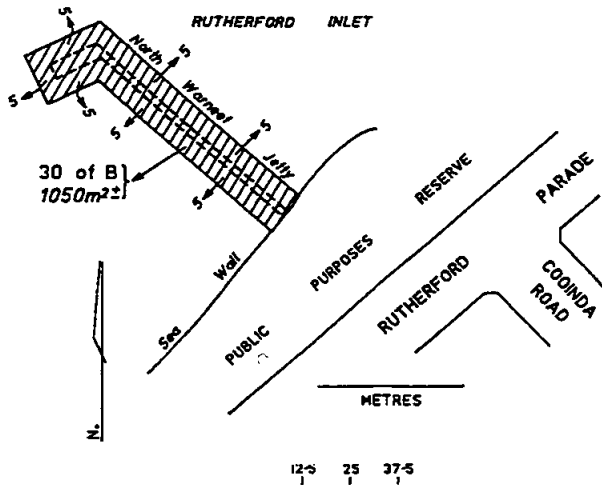

MUNICIPAL DISTRICT OF THE CITY OF WARRNAMBOOL

WARRNAMBOOL—Public purposes, 4 hectares, more or less, being Crown Allotment 3B, Section 3A, Township of Warrnambool, Parish of Wangoom as indicated by hatching on plan hereunder—(W 99[7]) (L2-4488).

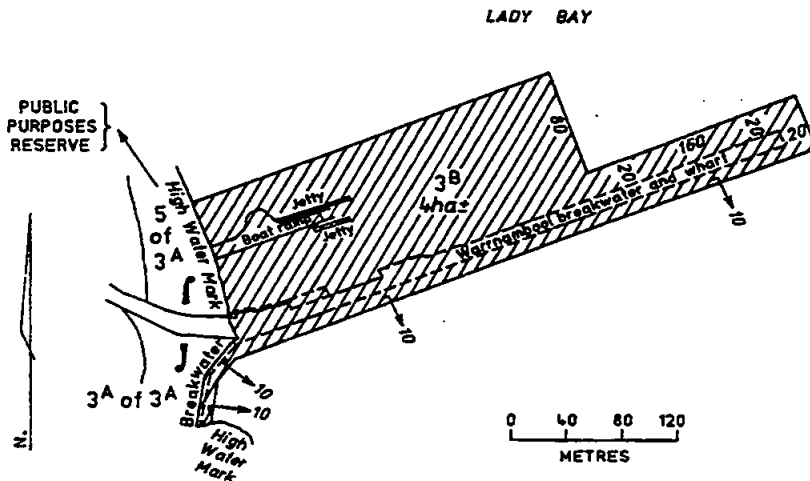

MUNICIPAL DISTRICT OF THE SHIRE OF EAST GIPPSLAND

WELSHPOOL—Public purposes, 210 hectares, more or less, being Crown Allotment 35H, Section B, Parish of Welshpool as indicated by hatching on plan hereunder—(P 189[2]) (15-10820).

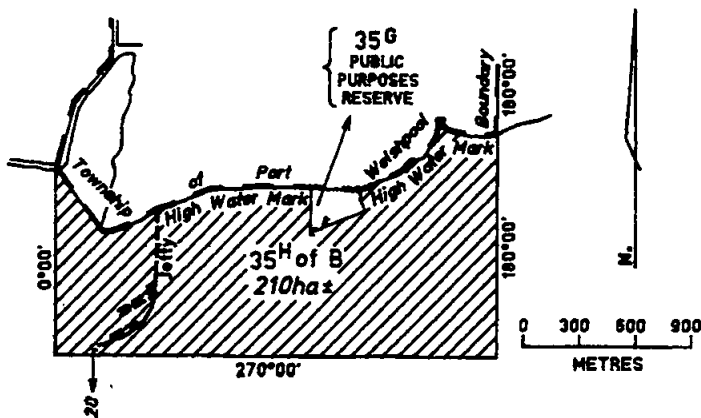

Dated 27 June 1995
 Responsible Minister:
 M. A. BIRRELL
 Minister for Conservation and Environment

KATHY WILSON
 Clerk of the Executive Council

Crown Land (Reserves) Act 1978
BARWON HEADS PARK

The Governor in Council under section 14A (7) of the **Crown Land (Reserves) Act 1978** dissolves the "Barwon Heads Park Committee of Management Incorporated" constituted by Order in Council of 25 September 1984 published in the Victoria Government Gazette on 3 October 1984—page 3467—(MGR 5887).

Dated 27 June 1995

Responsible Minister:

M. A. BIRRELL
Minister for Conservation and Environment

KATHY WILSON
Clerk of the Executive Council

Crown Land (Reserves) Act 1978
OCEAN GROVE FORESHORE RESERVE

The Governor in Council under section 14A (7) of the **Crown Land (Reserves) Act 1978** dissolves the "Ocean Grove Foreshore Reserve Committee of Management Incorporated" constituted by Order in Council of 12 August 1986 published in the Victoria Government Gazette on 20 August 1986—page 3158—(MGR 5947).

Dated 27 June 1995

Responsible Minister:

M. A. BIRRELL
Minister for Conservation and Environment

KATHY WILSON
Clerk of the Executive Council

Crown Land (Reserves) Act 1978
INCORPORATION OF COMMITTEE OF
MANAGEMENT OF BARWON HEADS
AND OCEAN GROVE FORESHORE
RESERVES

The Governor in Council, under section 14A (1) of the **Crown Land (Reserves) Act 1978**, being satisfied that it is in the public interests to declare to be a corporation the Committee of Management appointed under section 14 (2) of the Act of the lands described in the schedule hereunder:

- (a) declares that the Committee of Management shall be a corporation;
- (b) assigns the name "Barwon Coast Committee of Management Incorporated" to the corporation; and

under section 14B (3) of the Act, appoints Diane James to be Chairperson of the corporation.

SCHEDULE

1. The lands in the Parish of Bellarine shown coloured red on plan marked B/19.10.1983 attached to Department of Conservation and Natural Resources correspondence No. 07/1875 and known as the "Ocean Grove Foreshore Reserve".

2. The land in the Parish of Conewarre shown coloured red and brown on plan marked C/7.2.44 attached to Department of Conservation and Natural Resources correspondence No. 07/1587 and known as the "Barwon Heads Park".

3. The land in the Parish of Conewarre shown coloured green on plan marked C/10.9.52 attached to Department of Conservation and Natural Resources correspondence No. 07/1587 and known as the "Barwon Heads Foreshore (Thirteenth Beach)".

4. The remaining portion of the land in the Parish of Conewarre temporarily reserved by Orders in Council dated 17 July 1962 and 11 April 1972 as sites for public purposes and recreation and known as the "Barwon Heads Public Purposes and Recreation Reserve".

Such incorporation and appointment to come into effect on 1 July 1995.

Dated 27 June 1995

Responsible Minister:

M. A. BIRRELL
Minister for Conservation and Environment

KATHY WILSON
Clerk of the Executive Council

County Court Act 1958
DETERMINATION OF THE RIGHT OF A
JUDGE TO A PENSION

Under section 14 (3A) of the **County Court Act 1958**, the Governor in Council determines that the right of Judge Clive William Harris to a pension under section 14 (2) of the Act shall not be suspended while he is Acting Chairperson of the Solicitors' Board from 8 July 1995 until 31 December 1995 (inclusive).

Dated 27 June 1995

Responsible Minister:

JAN WADE
Attorney-General

KATHY WILSON
Clerk of the Executive Council

Land Act 1958
VESTING OF LAND UNDER SECTION 22A

The Governor in Council under section 22A of the **Land Act 1958** hereby vests in the Grain Elevators Board all the land described in the attachment subject to and in accordance with the agreement dated 4 October 1994 between the Public Transport Corporation and the Grain Elevators Board a copy of which agreement is set out in Schedule 2 to the Order in Council dated 20 December 1994 and published in the Government Gazette on 22 December 1994 at pages 3444 to 3461 (both inclusive) and for the appropriate purposes of the Grain Elevators Board.

Attachment

Land Act 1958
VESTING OF LAND UNDER SECTION 22A

The estate in fee simple down to the depth of 15 metres below the surface in the following parcels of land—

<i>Crown Description</i>	<i>Affected GEB Land and Relevant Plans (attached) (As per Schedule 1 to the Agreement)</i>	<i>Special Conditions (As per Schedule 2 to the Agreement) (Please also see Note 1 and 2 below)</i>
Crown Allotment 7 of No Section Township of Bannerton (CP 114795)	Bannerton	(a) PTC radio/communication facility with separate space 20 m by 20 m to be licensed with guaranteed power supply. (b) GEB to note that the site is encumbered by lease known as Lot 9.
Crown Allotment 23M Parish of Myall (CP 114721)	Bolton	
Crown Allotment 7C Section 34B Township of Dunolly (CP 114817-A)	Dunolly	(a) The rights in favour of the PTC specified in Schedule 3 to apply to the land vested in the GEB known as Crown Allotments 2, 7E of Section 34B and a 3 metre strip adjacent to the land vested in the PTC at the western side of CA's 8 and 12A Section 35A Township and Parish of Dunolly. (b) Easements to be provided for SECV services.
Crown Allotment 50B Parish of Galaquil (CP 114864)	Galaquil	(a) GEB to license the private electricity service and notify SECV of status.
Crown Allotment 12 and 13 Township of Hopetoun (CP 114716)	Hopetoun	(a) Easement to be provided for water service. (b) Easements to be provided for ATC cables.
Crown Allotment 5A Parish of Jeparit (CP 114796)	Jeparit	(a) Easement to be provided for SECV services. (b) GEB to notify water authority of its new owner liability.

<i>Crown Description</i>	<i>Affected GEB Land and Relevant Plans (attached) (As per Schedule 1 to the Agreement)</i>	<i>Special Conditions (As per Schedule 2 to the Agreement) (Please also see Note 1 and 2 below)</i>
		(c) GEB to note that the site is encumbered by lease known as Lot 27. (d) Easement to be provided for water service.
Crown Allotment 24E Parish of Kinabulla (CP 114749)	Kinnabulla	(a) Easement needed for drainage channel. (b) Easement to be provided for ATC service. (c) GEB to note that the site is encumbered by lease known as Lot 1.
Crown Allotment 1Q Parish of Burrumbeep (CP 114689)	Langi Logan	(a) National Rail Corporation approval to the transfer required. (b) GEB to note that the site is encumbered by lease known as Lot 5.
Crown Allotment 1C Parish of Minapre (CP 114640-A)	Lascelles	(a) Easements to be provided for SECV services.
Crown Allotment 24 of 1 Township of Linga (CP 114774)	Linga	(a) Easement to be provided for ATC cables. (b) Easements to be provided for SECV services. (c) Access to be provided for the duration of the lease for Lot 1.
Crown Allotment 16B Parish of Mirampiram (CP 113363-A)	Miram	(a) GEB to note that the site is encumbered by lease known as Lot 16.
Crown Allotment 6 of No Section Township of Tungamah (CP 114573)	Tungamah	(a) GEB to notify water authority of its new owner liability. (b) Easement to be provided for water service.
Crown Allotment 36G Parish of Gorya (CP 114866)	Turriff	(a) Easement to be provided for ATC cable.
Crown Allotments 32B and 32C Parish of Nullawil (CP 114959)	Warne	(a) GEB to note that the site is encumbered by lease known as Lot 2.
Crown Allotment 14 Section A Parish of Yaapeet (CP 114865)	Yaapeet	(a) GEB to respect any licences over land to be transferred.

Note: 1. Conditions 1 to 8 of Schedule 3 shall apply to the lands listed above if applicable.

2. Line of sight conditions as set out in Clause 4 of the Agreement apply where indicated on the plans attached to Schedule 1 (Column 2 above).

Hatched Area
Refer Clause 4.5
Lines of Sight Restrictions Apply

Shaded Area
Refer Schedule 3, Item 1
Rights in Favour of PTC

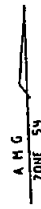
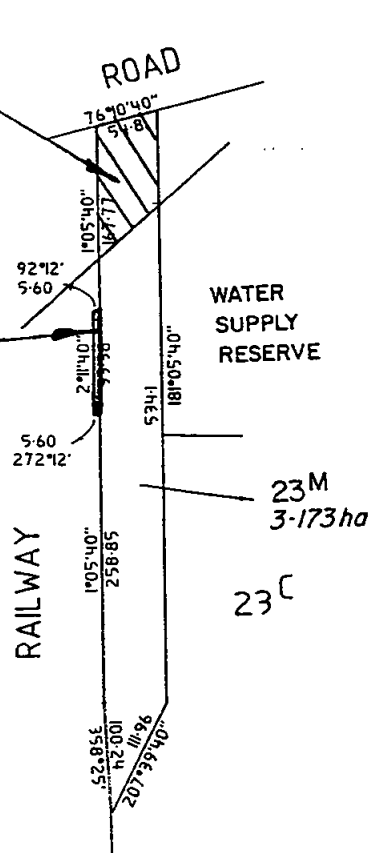

BOLTON

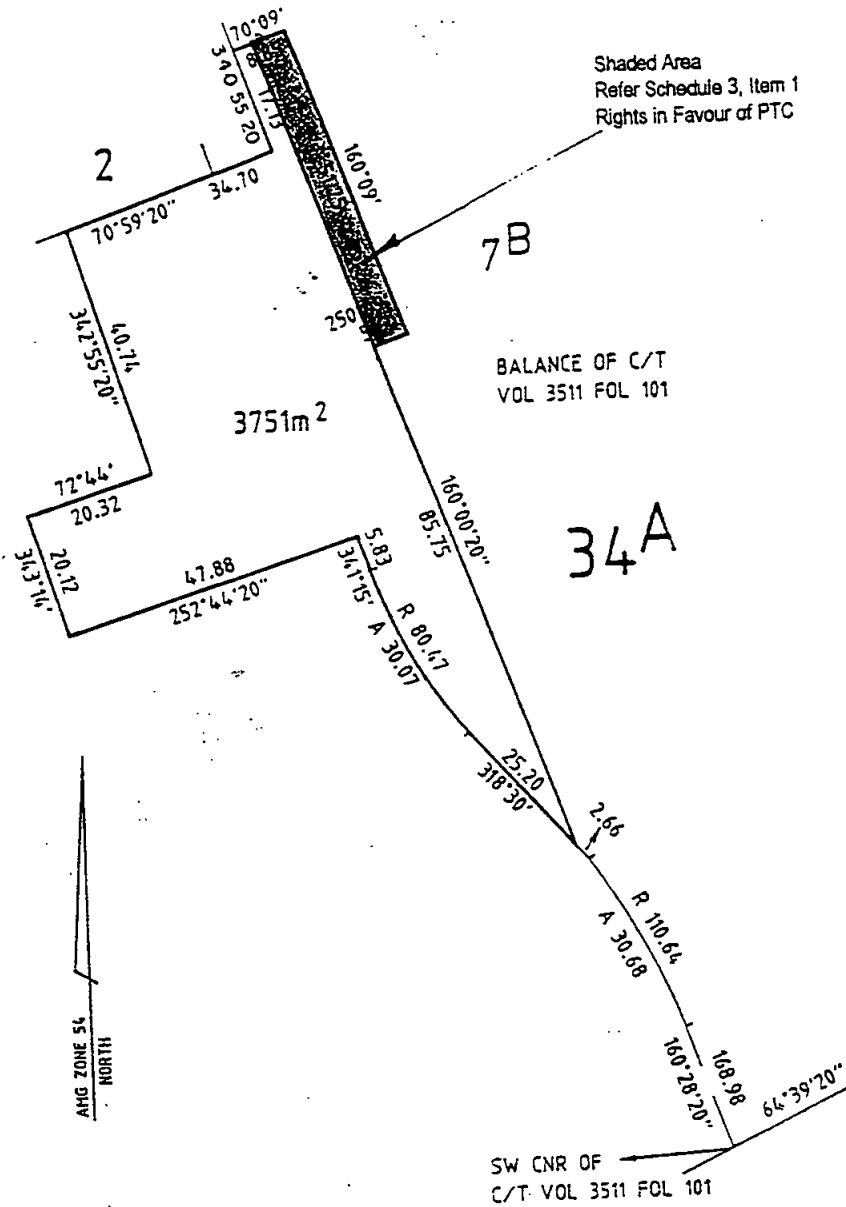

DUNOLLY

Shaded Area
Refer Schedule 3, Item 1
Rights in Favour of PTC

50 B
1.909ha

RAILWAY
(GALAQUIL STATION GROUND)

AMG
ZONE 54

ROAD

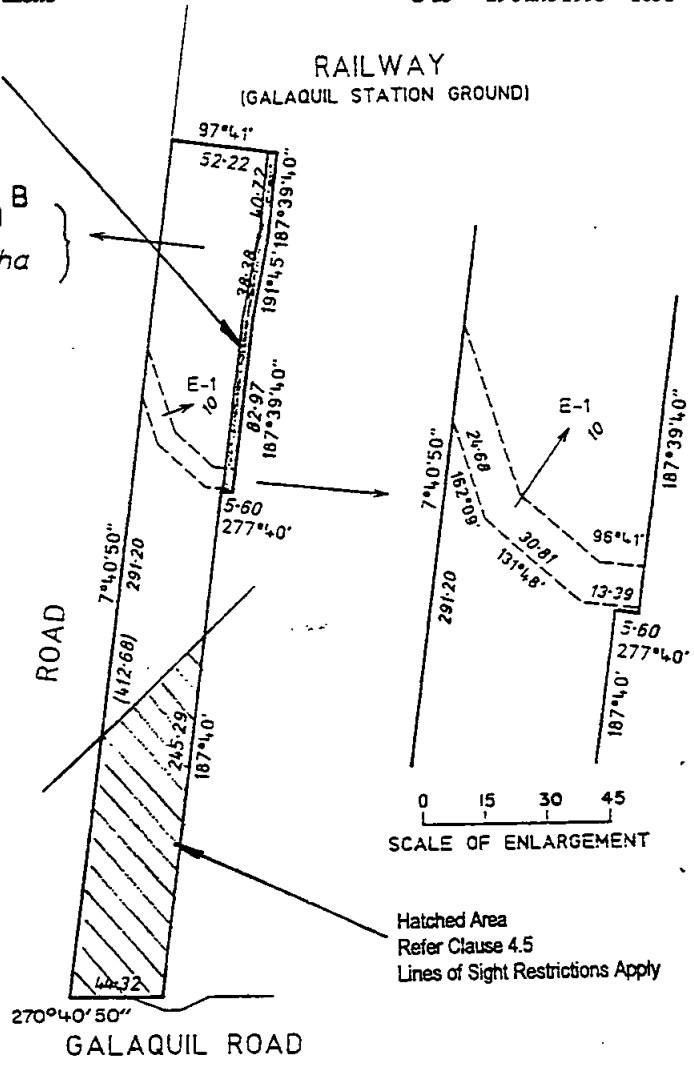

Hatched Area
Refer Clause 4.5
Lines of Sight Restrictions Apply

GALAQUIL

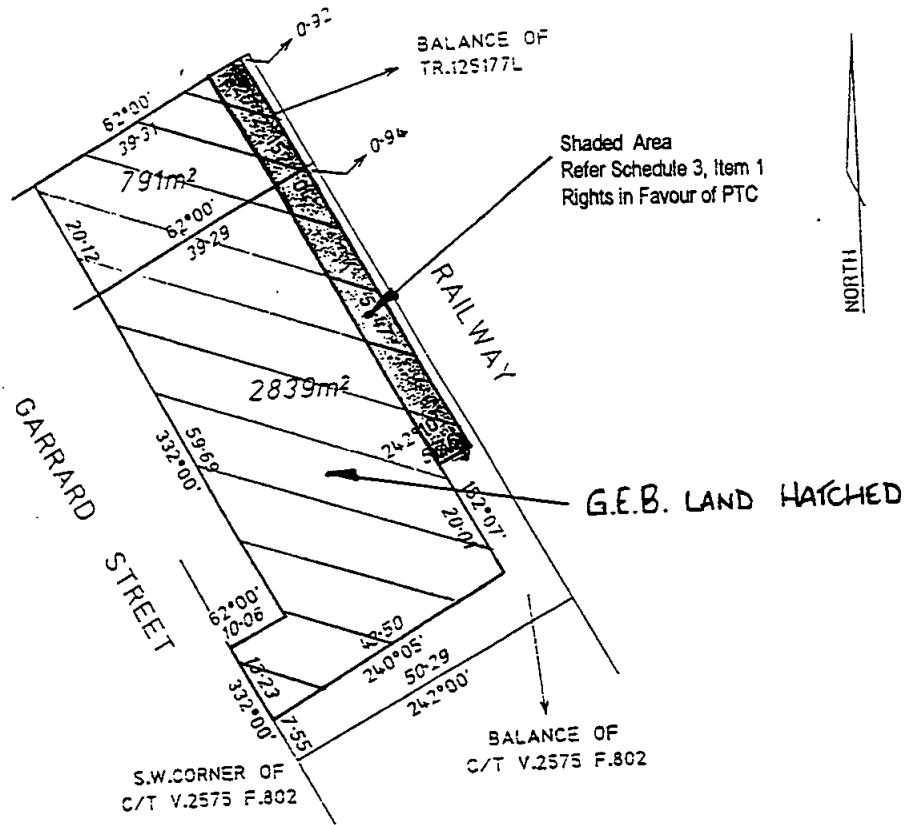

HOPETOUN

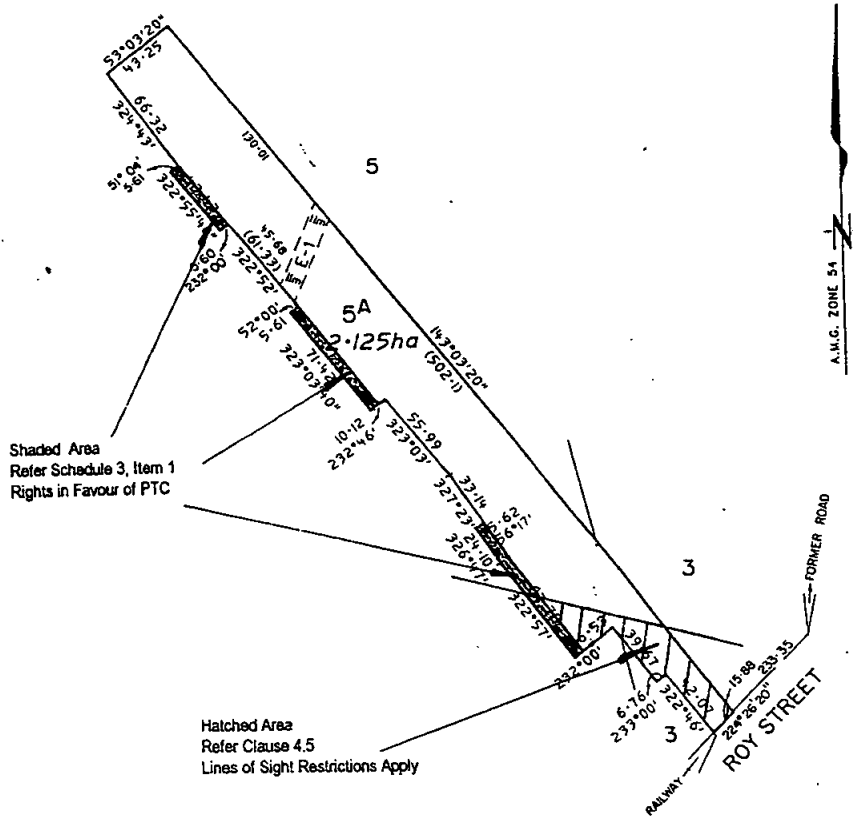

GOVERNMENT ROAD

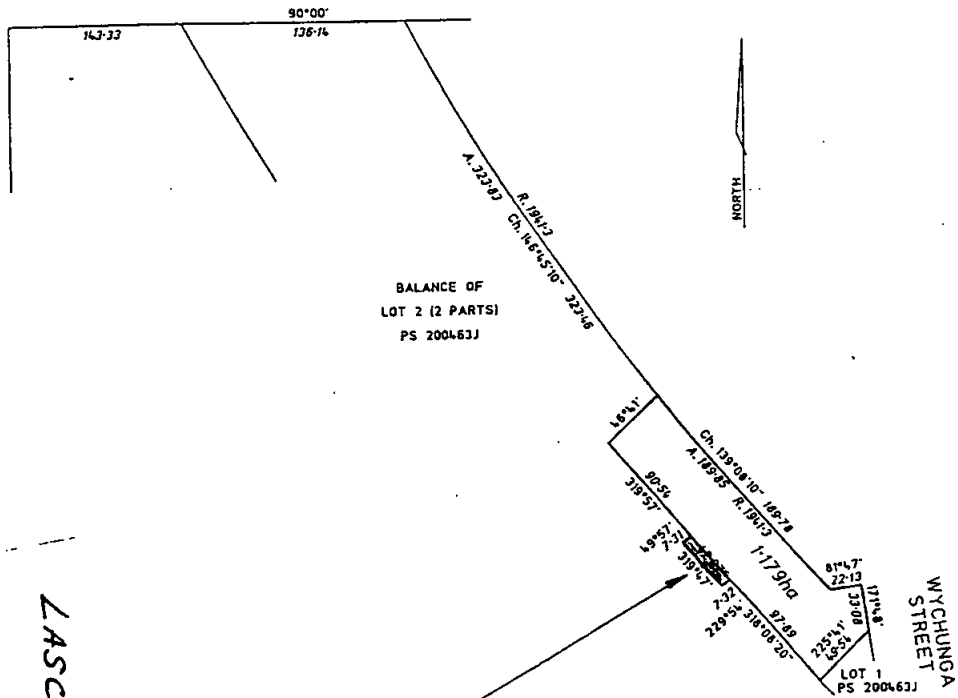

LASCHELLS

Shaded Area
Refer Schedule 3, Item 1
Rights in Favour of PTC

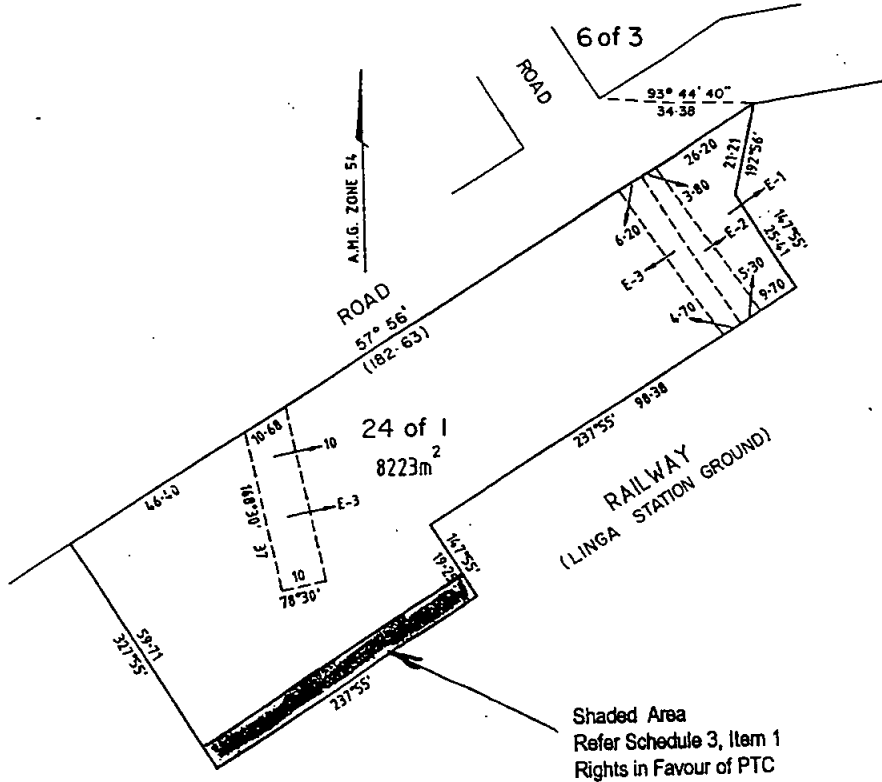

LINGA

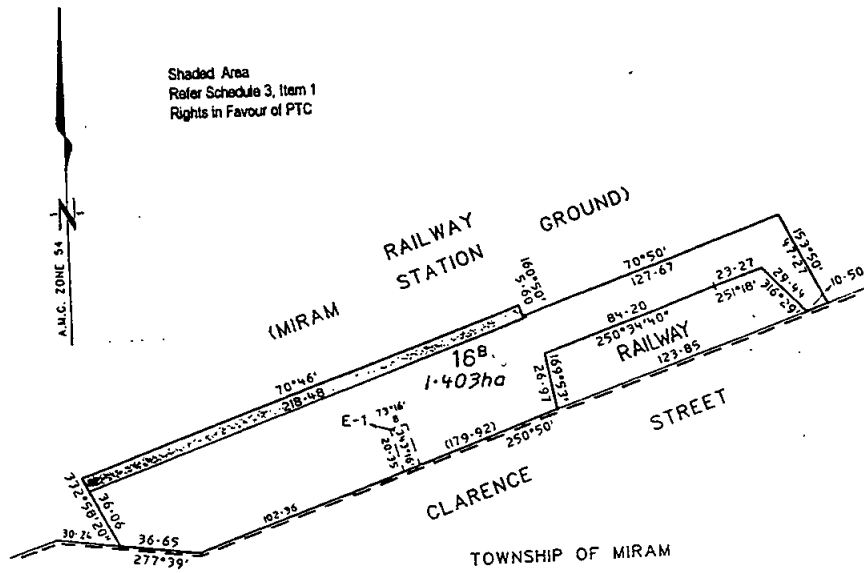

MIRAM

TUNGAMAH

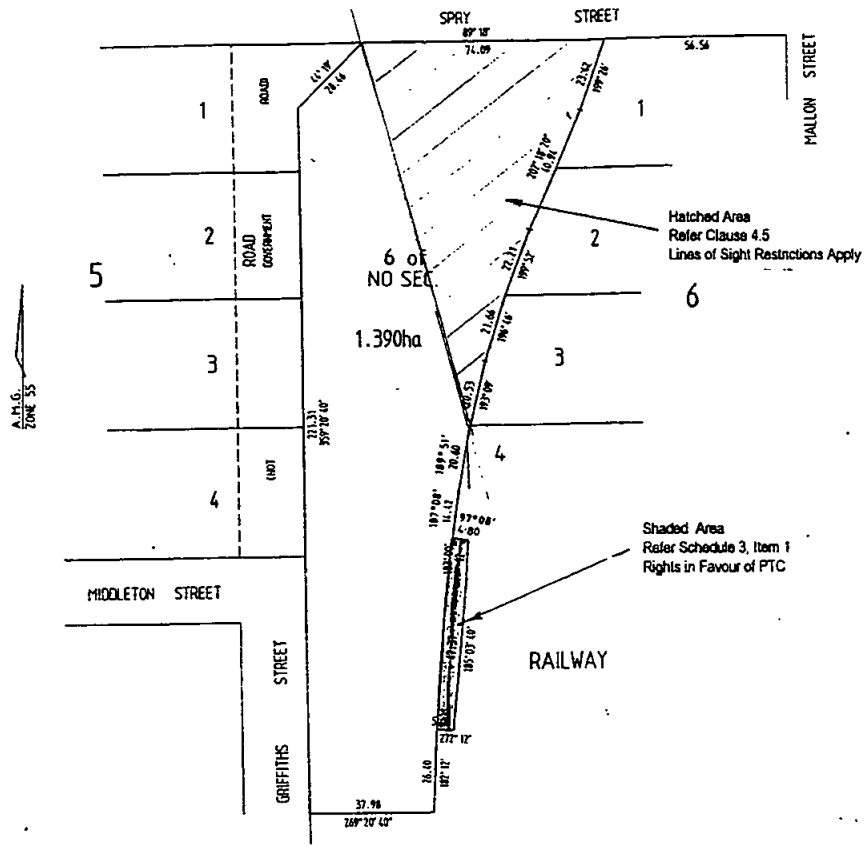

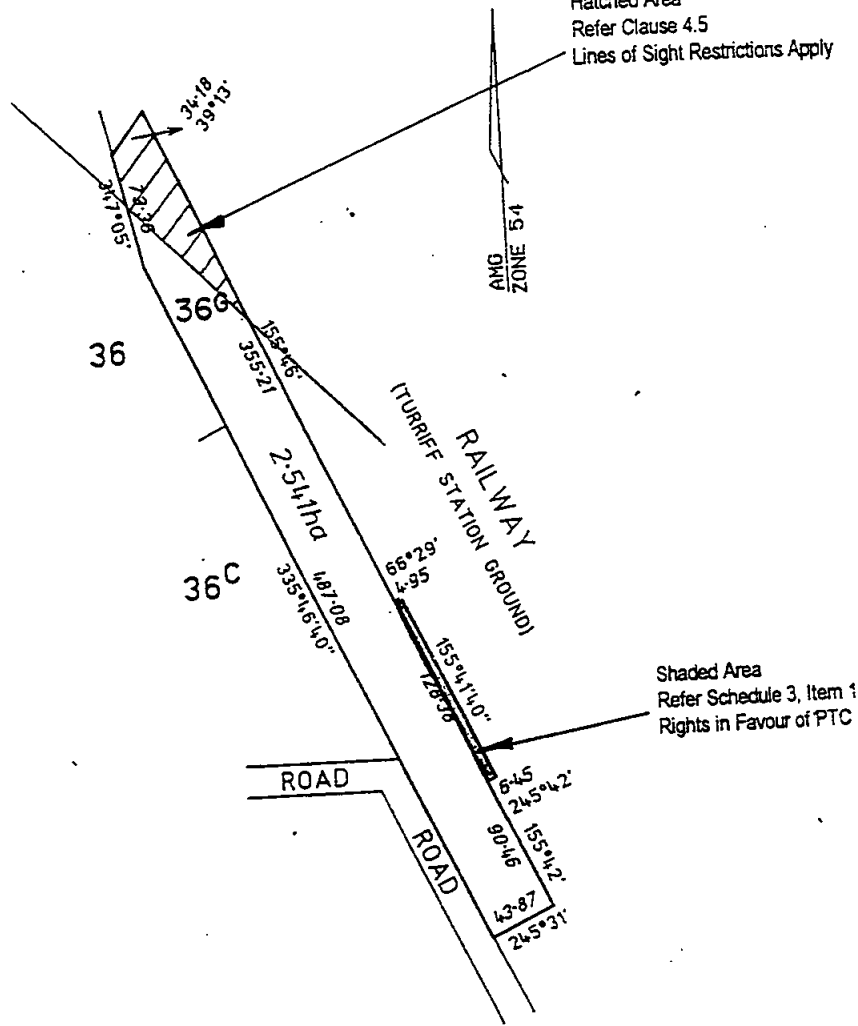

TURRIFF

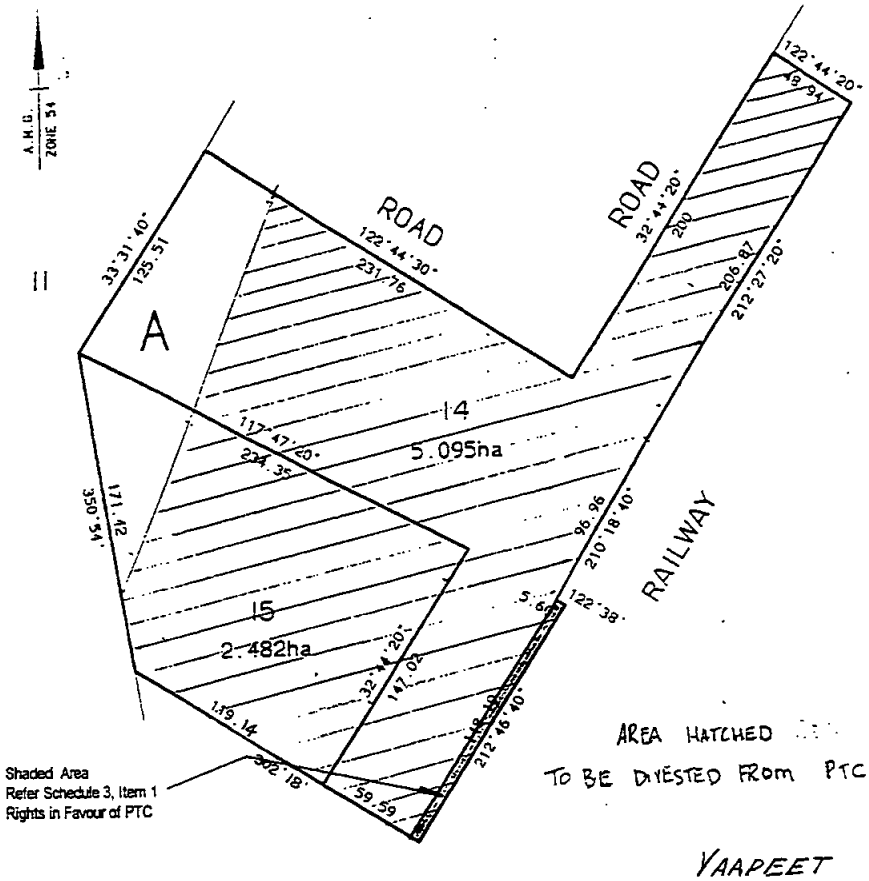

Dated 27 June 1995
Responsible Minister:
ROGER HALLAM
Minister for Finance

KATHY WILSON
Clerk of the Executive Council

**Electricity Industry Act 1993
ORDER UNDER SECTION 158B**

The Governor in Council acting under section 158B of the **Electricity Industry Act 1993** hereby makes the following Order:

1. AUTHORISING PROVISIONS

This Order is made under section 158B of the **Electricity Industry Act 1993** (the "Act").

2. OBJECTIVE

This Order regulates the amounts which the State Electricity Commission of Victoria ("SECV") is entitled to receive under the Pool Rules (as defined in the Act) for or in respect of electricity supplied to it under the Power Supply Agreement (as defined in the Act) with the object of ensuring that, if the amount otherwise received by SECV for the sale of that electricity is less than the cost of its supply to SECV, the amount SECV is entitled to receive under the Pool Rules is increased so as to recover up to (but not more than) 51 per cent. of that deficiency.

3. MODIFICATION OF POOL RULES

3.1 Modification as from 1 July 1995

So as to give effect to the objective of this Order, as from 1 July 1995 the Pool Rules apply as modified in the manner set out in the Schedule.

3.2 Subsequent reductions to LYB Uplift Payments

(a) If at any time a notice signed by the Treasurer and published in the Government Gazette:

- (i) specifies an amount for, or a method of determining an amount for, LYB Uplift Payment Rate (1) for the purposes of rule 160.3 of the Pool Rules which is less than the amount for, or is a method resulting in a lesser amount than the amount for, LYB Uplift Payment Rate (1) specified in the Pool Rules as at the time of publication of the notice; or
- (ii) specifies an amount for, or a method of determining an amount for, the value derived under paragraph (c) (1) of rule 160.4 of the Pool Rules which is less than the amount for, or is a method resulting in a lesser amount than the amount for, the value derived under paragraph (c) (1) of rule 160.4 of the Pool Rules as at the time of publication of the notice,

the Pool Rules apply as modified by the notice, to the extent necessary to give effect to that specified amount or method only, from the later of the date specified in the notice and the date which is 14 days after publication of the notice in the Government Gazette.

(b) If a notice signed by the Treasurer and published in the Government Gazette:

- (i) specifies an amount for, or a method of determining an amount for, the value derived under paragraph (c) (1) of rule 160.4 of the Pool Rules which is more than the amount for, or is a method resulting in a greater amount than the amount for, the value derived under paragraph (c) (1) of rule 160.4 of the Pool Rules at the time of publication of the notice; and
- (ii) a notice having that effect has not previously been signed by the Treasurer and published in the Government Gazette,

the Pool Rules apply as modified by the notice, to the extent necessary to give effect to that specified amount or method only, from the later of the date specified in the notice, the date which is 14 days after publication of the notice in the Government Gazette and 1 January 2001.

3.3 Other subsequent modifications

If a modification to the Pool Rules made in accordance with the licence issued to Victorian Power Exchange under Part 12 of the Act would have the effect of modifying in a material respect the modifications to the Pool Rules made by this Order, those modifications take effect only insofar as they do not have that effect unless they are submitted to the Treasurer and the Treasurer, by notice published in the Government Gazette, states that he or she is satisfied that the modifications are not inconsistent with clause 2, 3.1 or 3.2 of this Order.

Dated 20 June 1995

Responsible Minister:

ALAN R. STOCKDALE
Treasurer

KATHY WILSON
Clerk of the Executive Council

SCHEDULE TO ORDER UNDER SECTION
158B OF THE ELECTRICITY INDUSTRY
ACT

To give effect to the Order, the VicPool Rules are to be amended in the manner set out below with effect on and from 1 July 1995.

1. Rule 10.1—Definitions

Rule 10.1 is to be amended by inserting in alphabetical order the following definitions in rule 10.1:

“CPI” means the Consumer Price Index compiled by the Australian Bureau of Statistics for Melbourne (Capital City) (all groups).

“CPI Calculation Date” means 30 June in each Financial Year.

“Due LYB Uplift Payment” means the payment, expressed in \$, determined under rule 160.5(a) for each Pool Customer (excluding Snowy Trader and Interconnection Operating Agreement Trader).

“Energy Table” means, in relation to a Pool Customer, a table setting out the estimated franchise customer load of the Pool Customer for each Payment Period (or parts thereof) from 1 July 1995 to 31 December 2000 prepared by VPX and approved by the Pool Customer (or, if not approved by the Pool Customer on or before 1 July 1995, approved by the Treasurer or his nominee) on the basis of data provided by or on behalf of the Pool Customer to VPX for the purpose of estimating that load as at 31 May 1995.

“Financial Year” means a year ending on 30 June.

“Index Number” means the index number compiled and issued by the Australian Bureau of Statistics for the CPI for and in respect of a particular Quarter.

“LYB Uplift Payment” means the payment, expressed in \$, determined under rule 160.2 (c) for a Payment Period (or part thereof) for a Pool Customer (excluding Snowy Trader and Interconnection Operating Agreement Trader).

“LYB Uplift Payment (1)” means the component of the LYB Uplift Payment for a Payment Period (or part thereof) as determined under rule 160.3.

“LYB Uplift Payment (2)” means the component of the LYB Uplift Payment for a Payment Period (or part thereof) as determined under rule 160.4.

“LYB Uplift Payment Adjustment” means the adjustment to the LYB Uplift Payment

payable by a Pool Customer (excluding Snowy Trader and Interconnection Operating Agreement Trader) calculated under rule 160.6 (a).

“LYB Uplift Payment Rate (1)” means the rate, expressed in \$/MWh, determined under rule 160.3 (e).

“LYB Uplift Payment Rate (2)” means the rate, expressed in \$/MWh, determined under rule 160.4 (c).

“LYB Uplift Payment Review Date” means each of 31 December, 31 March, 31 May and 30 June in each Financial Year.

“Loy Yang B Power Station” has the meaning given to “power station” in the Loy Yang B Act 1992.

“Loy Yang B Power Supply Agreement” means the Power Supply Agreement referred to in the Agreement set out in Schedule 1 of the Loy Yang B Act 1992.

“Loy Yang B Trading Loss” means, in respect of a Financial Year, the amount expressed in \$, determined in accordance with rule 160.8 for that Financial Year.

“Quarter” means the respective 3 monthly periods adopted by the Australian Bureau of Statistics for the compilation and issue of the CPI.

“Tabulated Energy” means the data concerning the amount of energy, expressed in MWh, specified for a Pool Customer (excluding Snowy Trader and Interconnection Operating Agreement Trader) for a Payment Period (or part thereof) either:

- (1) in the Energy Table relating to that Pool Customer;
- (2) if not specified in the Energy Table relating to that Pool Customer, pursuant to rule 160.3 (c); or
- (3) if VPX has exercised its power under rule 160.3 (d), by VPX.

“Treasurer” means the Treasurer of the State of Victoria.

“UP(2) Formula” means that formula which pursuant to rule 160.4 (c) (2) is to be used to determine the LYB Uplift Payment Rate (2) for a Payment Period (or part thereof).

“UP (1) Tabulated Energy” means that component of Tabulated Energy, expressed in MWh, calculated under rule 160.3 (b).

“UP (2) Tabulated Energy” means that component of Tabulated Energy, expressed in MWh, calculated under rule 160.4 (b).”

2. Rule 50—Participants

Rules 50.5 and 50.6 are to be amended so that they read as follows:

“50.5 Date of Cessation

The person will cease to be a Participant when all payments due to be paid by it or to it under these rules have been made, including, in the case of a person who was a Pool Customer, any LYB Uplift Payment or LYB Uplift Payment Adjustment amounts which are or become payable by it or to it under rule 160.

50.6 Effect of Cessation

A Participant which is subject to a liability under these rules (including, in the case of a person who was a Pool Customer, any LYB Uplift Payment or LYB Uplift Payment Adjustment amounts which are or become payable by it or to it under rule 160), remains subject to that liability after and despite ceasing to be a Participant regardless of when the claim is made.”

3. Rule 160—Determination of Pool Customer charges

Rule 160 is to be amended by:

3.1 inserting the heading “160.1 Pool Customer Electricity Charges” immediately after the heading “160 Determination of Pool Customer charges”; and

3.2 inserting the following new rules at the end of rule 160 as rules 160.2 to 160.8:

“160.2 LYB Uplift Payment

(a) Subject to Rule 160.2 (d), each Pool Customer is liable to pay the LYB Uplift Payment in respect of electricity received and (in the case of a Pool Customer having Tabulated Energy) estimated to be received by it in a Financial Year if the Loy Yang B Trading Loss is, or is estimated to be, an amount greater than zero in the preceding Financial Year.

(b) The LYB Uplift Payment shall cease to be payable as from the commencement of the Financial Year immediately following the Financial Year in which Loy Yang B Trader permanently or indefinitely ceases to supply electricity.

(c) The LYB Uplift Payment payable by a Pool Customer (excluding Snowy Trader and Interconnection Operating Agreement Trader) in respect of a Payment Period (or part thereof) is calculated by applying the following formula:

$$UP(1) + UP(2)$$

where:

UP(1) is LYB Uplift Payment (1); and

UP(2) is LYB Uplift Payment (2).

(d) Neither Snowy Trader nor Interconnection Operating Agreement Trader is liable to pay either the LYB Uplift Payment or the LYB Uplift Payment Adjustment nor are amounts for LYB Uplift Payment (1) and LYB Uplift Payment (2) to be calculated for them.

(e) Subject to rules 160.2 (f) and (g), Loy Yang B Trader will be entitled to receive all LYB Uplift Payment amounts received by VPX pursuant to this rule 160.2.

(f) If the LYB Uplift Payment for a Pool Customer (excluding Snowy Trader and Interconnection Operating Agreement Trader) calculated under rule 160.2 (c) for a Payment Period is a negative value:

- (1) Loy Yang B Trader will pay that amount to VPX; and
- (2) VPX will, subject to rule 160.2 (h), pay that amount to the Pool Customer,

in accordance with rule 180. VPX may, at its own discretion, off-set any such amounts against either any Supply Payments to be paid by the Pool Customer or against any amounts to be paid to Loy Yang B Trader pursuant to rule 160 (as the case may be).

(g) If, for a given Financial Year, Loy Yang B Trader has, under rule 160.8 (c), advised VPX that it estimates that the Loy Yang B Trading Loss for a Financial Year will be an amount greater than zero and subsequently Loy Yang B Trader notifies VPX that the Loy Yang B Trading Loss for that Financial Year is zero, VPX (acting as the agent of Loy Yang B Trader) will, subject to receipt of the refund in cleared funds from Loy Yang B Trader under rule 190, refund to Pool Customers in accordance with rule 180 all LYB Uplift Payment payments made by them (net of any LYB Uplift Payment Adjustment amounts payable by or to them) in relation to that estimated Loy Yang B Trading Loss.

(h) If Loy Yang B Trader fails to pay to VPX any amount owing pursuant to rule 160.2(f) or rule 160.2 (g), the short-fall will be borne by all Pool Customers in proportion to the LYB Uplift Payment payable by Pool Customers in the relevant period. For this purpose, Pool Customers will be either required to accept a lesser amount from VPX under rule 160.2 (f) or rule 160.2 (g) or pay an additional amount to VPX under rule 160.2 (c) (in which case the

shortfall will be treated as if it were an additional part of the Loy Yang B Trading Loss for the previous Financial Year) (as the case may be).

(i) In collecting the LYB Uplift Payment from a Pool Customer, VPX will be acting as the agent of Loy Yang B Trader and not as a principal and is not liable for any loss, damage or expense suffered or incurred by a Pool Customer or Loy Yang B Trader as a consequence of any act or omission by VPX pursuant to either of rules 160 or 180.

160.3 LYB Uplift Payment (1)

(a) LYB Uplift Payment (1) for a Pool Customer in respect of a Payment Period (or part thereof) in a Financial Year is calculated by applying the following formula:

$$\text{UPR (1)} \times \text{TE (1)}$$

where:

UPR(1) is LYB Uplift Payment Rate (1) for the Payment Period (or part thereof); and

TE(1) is:

- (1) where the entire Payment Period occurs within the Financial Year, the Tabulated Energy for the Pool Customer for the Payment Period; and
- (2) where only part of the Payment Period occurs within the Financial Year, the UP(1) Tabulated Energy for the Pool Customer for that part of the Payment Period which occurs within the Financial Year.

(b) The UP (1) Tabulated Energy for a Pool Customer in respect of a Payment Period (or part thereof) in a Financial Year is calculated by applying the following formula:

$$\text{TE} \times \frac{\text{SP (1)}}{\text{SP}}$$

where:

TE is the Tabulated Energy for the Pool Customer for the Payment Period;

SP(1) is the number of Settlement Periods in the Payment Period which occur in the Financial Year; and

SP is the total number of Settlement Periods in the Payment Period.

(c) Subject to rule 160.3 (d), if no Tabulated Energy is specified in an Energy Table for a Pool Customer for a Payment Period (or part thereof), the Tabulated Energy for that Pool Customer for that Payment Period (or part thereof) is equal to zero.

(d) If the allocation of Tabulated Energy amongst Pool Customers specified in the Energy Tables of Pool Customers for a Payment Period (or part thereof) is not, in VPX's reasonable opinion, reasonable, having regard to the principles upon which the Energy Tables were prepared, VPX may in its sole and reasonable discretion, reallocate the specified amounts for Tabulated Energy amongst Pool Customers for that Payment Period (or part thereof). For this purpose, upon request by VPX, Pool Customers must provide VPX with such information as VPX requests concerning their franchise customer load as soon as is reasonably practicable after the request by VPX is made.

(e) LYB Uplift Payment Rate (1) is \$2/MWh or, if the Treasurer in exercising his or her powers under an Order made under section 158B of the EI Act specifies another rate for the purpose of this rule, then that rate, or a method of determining another rate for the purpose of this rule, then the rate determined by the application of that method.

160.4 LYB Uplift Payment (2)

(a) LYB Uplift Payment (2) for a Pool Customer in respect of a Payment Period (or part thereof) in a Financial Year is calculated by applying the following formula:

$$\text{UPR(2)} \times (\text{PCSD} - \text{TE (2)})$$

where:

UPR(2) is LYB Uplift Payment Rate (2) for the Payment Period (or part thereof);

PCSD is:

- (1) where the entire Payment Period occurs within the Financial Year and:
 - (a) does not include an LYB Uplift Payment Review Date; or
 - (b) includes but ends on an LYB Uplift Payment Review Date,
 the total of all the Pool Customer Settlement Demand of the Pool Customer for the Payment Period; and
- (2) where the Payment Period includes but does not end on an LYB Uplift Payment Review Date, the total of all the Pool Customer Settlement Demand of the Pool Customer:
 - (a) from the commencement of the Payment Period up to and including the relevant LYB Uplift Payment Review Date where the Payment Period commences in the Financial Year and the relevant

part of the Payment Period is that which occurs prior to the LYB Uplift Payment Review Date;

- (b) from the commencement of the Financial Year up to and including the end of the Payment Period where the Payment Period commences in the previous Financial year; or
- (c) from the commencement of the day immediately following the LYB Uplift Payment Review Date to the end of the Payment Period where the Payment Period commences in the Financial Year and the relevant part of the Payment Period is that which occurs after the LYB Uplift Payment Review Date.

TE(2) is:

- (1) where the entire Payment Period occurs within the Financial Year and:
 - (a) does not include an LYB Uplift Payment Review Date; or
 - (b) includes but ends on an LYB Uplift Payment Review Date, the Tabulated Energy for the Pool Customer for the Payment Period; and
- (2) where the Payment Period includes but does not end on an LYB Uplift Payment Review Date, the UP(2) Tabulated Energy for the Pool Customer for that part of the Payment Period:
 - (a) from the commencement of the Payment Period up to and including the relevant LYB Uplift Payment Review Date where the Payment Period commences in the Financial Year and the relevant part of the Payment Period is that which occurs prior to the LYB Uplift Payment Review Date;
 - (b) from the commencement of the Financial Year up to and including the end of the Payment Period where the Payment Period commences in the previous Financial Year; or
 - (c) from the commencement of the day immediately following the LYB Uplift Payment Review Date to the end of the Payment Period

where the Payment Period commences in the Financial Year and the relevant part of the Payment Period is that which occurs after the LYB Uplift Payment Review Date.

- (b) The UP (2) Tabulated Energy for a Pool Customer (excluding Snowy Trader and Interconnection Operating Agreement Trader) in respect of a Payment Period (or part thereof) in a Financial Year up to and including either the relevant LYB Uplift Payment Review Date or the end of the Payment Period (as the case requires) in a Financial year is calculated by applying the following formula:

$$TE \times \frac{SP(2)}{SP}$$

where:

TE is the Tabulated Energy for the Pool Customer for the Payment Period;

SP(2) is the number of Settlement Periods in that part of the Payment Period for which the LYB Uplift Payment (2) for a Pool Customer is being determined under rule 160.4(a); and

SP is the total number of Settlement Periods in the Payment Period.

- (c) Subject to rules 160.4 (d) to 160.4 (f) inclusive, the LYB Uplift Payment Rate (2) for a Payment Period (or part thereof) in a Financial Year is the lesser of the following rates:

- (1) the rate determined by VPX on or before the CPI Calculation Date in the immediately preceding Financial Year using the following formula:

$$ALR(1) \times \frac{NCPI}{OCPI}$$

where:

ALR(1) is \$2/MWh;

NCPI is the Index Number for the Quarter ending on 31 March in the same Financial Year as the CPI Calculation Date; and

OCPI is the Index Number for the Quarter ending on 31 March 1995,

or, if the Treasurer in exercising his or her powers under an Order made under section 158B of the EI Act specifies another rate for the purpose of this rule, then that rate, or a method for determining another rate for the

purpose of this rule, then the rate determined by the application of that method; and

- (2) (i) for Payment Periods (or parts thereof) up to and including the first LYB Uplift Payment Review Date in the Financial Year, the rate determined by VPX by applying the following formula:

$$\frac{(0.51 \times \text{LYL}) - (\text{STE} \times \text{UP} (1))}{\text{FPCSD} - \text{STE}}$$

where:

LYL is the Loy Yang B Trading Loss (if any) for the immediately preceding Financial Year;

STE is the sum of all Tabulated Energy for all Pool Customers (excluding Snowy Trader and Interconnection Operating Agreement Trader) for all Payment Periods (or parts thereof) in the Financial Year;

UP (1) is LYB Uplift Payment Rate (1) for the Payment Period (or part thereof); and

FPCSD is VPX's estimate of the sum of all Forecast Pool Customer Settlement Demand for all Pool Customers (excluding Snowy Trader and Interconnection Operating Agreement Trader) for all Payment Periods (or parts thereof) in the Financial Year; and

- (ii) for Payment Periods (or parts thereof in the Financial Year) after the first and subsequent LYB Uplift Payment Review Dates in the Financial Year, the rate determined by VPX by applying the following formula:

$$\frac{(0.51 \times \text{LYL}) - (\text{STE} \times \text{UP} (1))}{(\text{APCSD} + \text{RFPCSD}) - \text{STE}}$$

where:

LYL has the meaning given to it in rule 160.4 (c) (2) (i);

STE has the meaning given to it in rule 160.4 (c) (2) (i);

UP (1) has the meaning given to it in rule 160.4 (c) (2) (i);

APCSD is the sum of all Pool Customer Settlement Demand for all Pool Customers (excluding Snowy Trader and Interconnection Operating Agreement Trader) for all Payment Periods (or parts thereof) from the beginning of the Financial Year up to and including the most recent LYB Uplift Payment Review Date; and

RFPCSD is VPX's estimate of the sum of all Forecast Pool Customer Settlement Demand for

all Pool Customers (excluding Snowy Trader and Interconnection Operating Agreement Trader) for all Payment Periods (or parts thereof) immediately following the most recent LYB Uplift Payment Review Date to the end of the Financial Year.

(d) For all Payment Periods (or parts thereof) in a Financial Year other than the Payment Period (or part thereof) containing the last LYB Uplift Payment Review Date in the Financial Year, LYB Uplift Payment Rate (2) cannot be less than -\$2/MWh and if the application of the UP(2) Formula under rule 160.4 (c) (2) gives a rate for the Payment Period (or part thereof) which is less than -\$2/MWh, the LYB Uplift Payment Rate (2) for that Payment Period (or part thereof) will be -\$2/MWh.

(e) If the application of the UP(2) Formula under rule 160.4 (c) (2) results in a numerator with a positive amount and a denominator that is not a positive amount, the LYB Uplift Payment Rate (2) for that Payment Period (or part thereof) will be the rate determined under rule 160.3 (e).

(f) If the application of the UP(2) Formula under rule 160.4 (c) (2) results in a numerator that is not a positive amount and a denominator which is zero, the LYB Uplift Payment Rate (2) for that Payment Period (or part thereof) will be zero.

160.5 Review of LYB Uplift Payment

(a) As soon as reasonably practicable after each LYB Uplift Payment Review Date in each Financial Year, VPX must calculate the Due LYB Uplift Payment for each Pool Customer (excluding Snowy Trader and Interconnection Operating Agreement Trader) from the commencement of the Financial Year up to and including the most recent LYB Uplift Payment Review Date by applying the following formula:

$$(\text{UPR}(1) \times \text{TTE}) + (\text{RUPR}(2) \times (\text{SCSD} - \text{TTE}))$$

where:

UPR (1) is LYB Uplift Payment Rate (1);

TTE is the total Tabulated Energy for the Pool Customer for all Payment Periods (or parts thereof) from the commencement of the Financial Year up to and including the most recent LYB Uplift Payment Review Date as determined under rule 160.5 (b); and

RUPR (2) is the LYB Uplift Payment Rate (2) as recalculated by VPX pursuant to rule 160.4 (c) (2) (ii) for application after the most recent LYB Uplift Payment Review Date or, if the LYB Uplift Payment Review Date is 30 June,

the LYB Uplift Payment Rate (2) as calculated by VPX using the formula contained in rule 160.4 (c) (2) (ii);

SCSD is the sum of all Pool Customer Settlement Demand of the Pool Customer from the commencement of the Financial Year up to and including the most recent LYB Uplift Payment Review Date.

(b) The total Tabulated Energy for a Pool Customer in respect of a Payment Period (or part thereof) in a Financial Year up to and including the most recent LYB Uplift Payment Review Date is calculated by applying the following formula:

$$TE \times \frac{SSP}{SP}$$

where:

TE is the total Tabulated Energy for the Pool Customer for the Payment Period;

SSP is the number of Settlement Periods in the Payment Period which occur after the commencement of the Financial Year up to and including the most recent LYB Uplift Payment Review Date; and

SP is the total number of Settlement Periods in the Payment Period.

160.6 LYB Uplift Payment Adjustment

(a) As soon as reasonably practicable after calculating the Due LYB Uplift Payment for each Pool Customer (excluding Snowy Trader and Interconnection Operating Agreement Trader) under rule 160.5 (a), VPX must calculate the LYB Uplift Payment Adjustment for each Pool Customer (excluding Snowy Trader and Interconnection Operating Agreement Trader) by applying the following formula:

$$DUP - AUP$$

where:

DUP is the Due LYB Uplift Payment for the Pool Customer from the commencement of the relevant Financial Year up to and including the most recent LYB Uplift Payment Review Date; and

AUP is the sum of all actual LYB Uplift Payment and LYB Uplift Payment Adjustment payments made by the Pool Customer minus all actual LYB Uplift Payment Adjustment payments made to the Pool Customer from the commencement of the relevant Financial Year up to and including the most recent LYB Uplift Payment Review Date.

(b) If the LYB Uplift Payment Adjustment for a Pool Customer is:

- (i) a positive amount, the Pool Customer must pay that amount to VPX in accordance with rule 180; and
- (ii) a negative amount, VPX will, subject to rule 160.6(d), pay that amount to the Pool Customer in accordance with rule 180.

The LYB Uplift Payment Adjustment will be included in the statement issued by VPX to the Pool Customer under rule 180 relating to the Payment Period containing the most recent LYB Uplift Payment Review Date. VPX may, at its own discretion, offset any LYB Uplift Payment Adjustment against any other Supply Payments to be paid by the Pool Customer.

(c) If the sum of all LYB Uplift Payment Adjustments is:

- (i) a positive amount, VPX will, subject to receipt of all LYB Uplift Payment Adjustments from Pool Customers, pay that amount to Loy Yang B Trader in accordance with rule 180; and
- (ii) a negative amount, Loy Yang B Trader will pay that amount to VPX for distribution to Pool Customers in accordance with rule 180.

The sum of all LYB Uplift Payment Adjustments will be included in the statement issued by VPX to Loy Yang B Trader under rule 180 relating to the Payment Period containing the most recent LYB Uplift Payment Review Date. VPX may, at its own discretion, offset any LYB Uplift Payment Adjustment against any amounts to be paid by Loy Yang B Trader pursuant to rule 160.

(d) If Loy Yang B Trader fails to pay to VPX any amount owing pursuant to rule 160.6(c), the short-fall will be borne by all Pool Customers in proportion to the LYB Uplift Payment Adjustment payable by or to Pool Customers for the relevant period. For this purpose, Pool Customers will be either required to accept a lesser amount from, or pay an additional amount to, VPX under rule 160.6 (in which case, the short-fall will be treated as if it were an additional part of the Loy Yang B Trading Loss for the previous Financial Year).

160.7 Review of Forecast Pool Customer Settlement Demand

(a) Between 1 May and 31 May in each Financial Year, each Pool Customer (excluding

Snowy Trader and Interconnection Operating Agreement Trader) must provide to VPX the Pool Customer's estimate of its own Forecast Pool Customer Settlement Demand for each calendar month in the immediately following Financial Year.

(b) Each Pool Customer (excluding Snowy Trader and Interconnection Operating Agreement Trader) must, at least 2 weeks prior to (but not more than 4 weeks prior to) each LYB Uplift Payment Review Date, provide to VPX a further estimate of its Forecast Pool Customer Settlement Demand for the remaining calendar months in the current Financial Year reviewed and, if necessary, revised to take into account any factors the Pool Customer reasonably considers to be relevant.

(c) If a Pool Customer does not provide VPX with the estimate of Forecast Pool Customer Settlement Demand as required pursuant to rule 160.7 (a) or rule 160.7 (b), VPX may make its own reasonable estimate of Forecast Pool Customer Settlement Demand for the Pool Customer for the relevant period for the purposes of rule 160.4.

160.8 Calculation of Loy Yang B Trading Loss

(a) Subject to rules 160.8 (b) and (c), the Loy Yang B Trading Loss for a Financial Year is the amount determined by Loy Yang B Trader by applying the formula:

AP - AR

where:

AP is the aggregate amount paid or payable by Loy Yang B Trader under the Loy Yang B Power Supply Agreement for or in respect of or in any way related to electricity generated by, or the capacity to deliver electricity generated by, the Loy Yang B Power Station, and under any hedge contracts to which it is a party, in the Financial Year; and

AR is the aggregate amount received or receivable by Loy Yang B Trader for or in respect of electricity supplied by it and under any hedge contracts to which it is a party (but excluding any payments it receives pursuant to either rules 160.2 or 160.6 or under the deed entitled "Tariffs and Charges Deed" dated 3 October 1994 between, among others, State Electricity Commission of Victoria and certain Pool Customers) in the Financial Year.

(b) If the Loy Yang B Trading Loss determined by Loy Yang B Trader under rule

160.8 (a) for a Financial Year is a negative amount, the Loy Yang B Trading Loss for that Financial Year will be deemed to be zero.

(c) Between 1 May and 31 May in each Financial Year, Loy Yang B Trader must advise VPX in writing of its estimate of the Loy Yang B Trading Loss for that Financial Year and until it advises VPX under rule 160.8(d) of the actual Loy Yang B Trading Loss for the relevant Financial year, the estimate will, for the purposes of these rules, be taken to be the Loy Yang B Trading Loss for that Financial Year.

(d) As soon as is reasonably practicable but in any event within 90 days after the end of each Financial Year Loy Yang B Trader must advise VPX in writing of the actual Loy Yang B Trading Loss for the relevant Financial Year.

(e) If Loy Yang B Trader does not advise VPX of the Loy Yang B Trading Loss for a Financial Year as required pursuant to rules 160.8 (c) and 160.8 (d), VPX must not calculate or collect LYB Uplift Payments due from or to Pool Customers during the following Financial Year unless and until Loy Yang B Trader notifies VPX of the Loy Yang B Trading Loss for that previous Financial Year.

(f) Loy Yang B Trader will ensure that the calculation of the Loy Yang B Trading Loss is audited by its auditors and that its auditors will provide to VPX as soon as reasonably practicable after the end of the Financial Year a certificate certifying that the calculation of the Loy Yang B Trading Loss has been carried out in accordance with generally accepted Australian accounting principles and practices and with this rule 160.8.

(g) Any certificate given to VPX by Loy Yang B Trader's auditors pursuant to rule 160.8 (f) will, upon reasonable prior notice from a Pool Customer, be made available by VPX for inspection at VPX's offices by that Pool Customer."

4. Rule 180—Payment

4.1 Rules 180.2 to 180.6 inclusive are to be amended so that they read as follows:

"180.2 Preliminary Statements

Within 5 Business Days after the end of each Payment Period, VPX must give:

- (a) each Participant a draft of the statement to be given to the Participant under rule 180.4 together with supporting data relating to the amount of electricity bought and sold in that

Payment Period and the prices at which that electricity was bought and sold by the Participant; and

- (b) Loy Yang B Trader a draft of the statement to be given to it under rule 180.4 together with such supporting data as VPX considers appropriate relating to that Payment Period.

180.3 Disputes

If VPX and any Participant or SECV disputes either the net amount stated in the draft statement given to it under rule 180.2 to be payable by or to it or the supporting data, VPX and the Participant or SECV (as the case may be) must use their reasonable endeavours to resolve the dispute within 18 Business Days of the end of the Payment Period. The dispute must be resolved by agreement or pursuant to rule 70.

180.4 Pool Manager to issue statements

Not later than 18 Business Days after the end of the Payment Period, VPX must give:

- (a) to each Pool Customer a statement stating the Supply Payments payable by the Pool Customer in respect of the relevant Payment Period together with any LYB Uplift Payment Adjustment amount payable to the Pool Customer;
- (b) to each Pool Generator a statement stating the amounts receivable under rule 150 and payable under rule 170 by the Pool Generator in respect of the relevant Payment Period; and
- (c) to Loy Yang B Trader a statement stating the amounts receivable or payable by Loy Yang B Trader under rule 160 in respect of the relevant Payment Period.

In cases where an amount stated in a draft statement issued under rule 180.2 has been the subject of a dispute and has been adjusted either by agreement between VPX and the Participant or by the Dispute Resolution Panel under rule 70:

- (d) if the dispute is resolved prior to VPX giving the final statement relating to the amount in dispute under this rule 180.4, the amount as adjusted will be included in that final statement; and
- (e) if the dispute is resolved after VPX gives the final statement relating to the amount in dispute under this rule 180.4, the adjustment agreed or determined will be included in the next

final statement given by VPX to the Participant under this rule 180.4 after the resolution of the dispute.

180.5 Payment by or to Pool Customers

- (a) No later than 12:00 noon on the twentieth Business Day after the end of the Payment Period, each Pool Customer must pay to VPX in cleared funds the net amount of the Supply Payment stated to be payable by that Pool Customer in that statement whether or not the Pool Customer disputes the net amount payable.
- (b) If an LYB Uplift Payment Adjustment amount is payable to a Pool Customer which exceeds the amount of the Supply Payment payable by that Pool Customer for the Payment Period to which the statement under rule 180.4 containing the LYB Uplift Payment Adjustment relates, subject to receipt in cleared funds from either Loy Yang B Trader or other Pool Customers, no later than 12:00 noon on the twentieth Business Day after the end of the Payment Period, VPX must pay to the Pool Customer in cleared funds the LYB Uplift Payment Adjustment amount stated to be payable to that Pool Customer in that statement (net of any Supply Payments stated to be payable by that Pool Customer in that statement) whether or not the Pool Customer or VPX disputes the net amount payable.

180.6 Payment to Pool Generators

On the Day on which VPX is to be paid under rule 180.5, VPX must pay to each Pool Generator in cleared funds the net amount stated to be payable to that Pool Generator in the relevant statement given to it under rule 180.4 (b)."

4.2 The following new rule 180.7 is to be inserted immediately after rule 180.6:

"180.7 Additional Payments to and from Loy Yang B Trader

- (a) If, in a statement given to Loy Yang B Trader under rule 180.4, a net amount is stated to be payable to Loy Yang B Trader, on the day on which VPX is paid under rule 180.5, VPX must pay to Loy Yang B Trader in cleared funds the net amount stated to be payable to Loy Yang B Trader in that statement.

- (b) If, in a statement given to Loy Yang B Trader under rule 180.4 a net amount is stated to be payable by Loy Yang B Trader, no later than 12:00 noon on the twentieth Business Day after the end of the Payment Period, Loy Yang B Trader must pay to VPX in cleared funds the net amount stated to be payable by Loy Yang B Trader in that statement whether or not Loy Yang B Trader disputes the net amount payable."

5. Rule 190—Refund Payments by Loy Yang B Trader

The following is to be inserted immediately before rule 195 as new rule 190:

"190. Refund Payments by Loy Yang B Trader

If, under rule 160.2 (g), VPX is required, subject to the receipt of the refund in cleared funds from Loy Yang B Trader under this rule 190, to refund LYB Uplift Payment made by Pool Customers, Loy Yang B Trader must refund all LYB Uplift Payment amounts it has received under rule 180.7 in relation to the estimated Loy Yang B Trading Loss to VPX within 20 Business Days of VPX so notifying Loy Yang B Trader."

**Electricity Industry Act 1993
ORDER UNDER SECTION 163A**

Order determining the fee payable in respect of the licence to sell electricity to franchise customers issued under Part 12 of the **Electricity Industry Act 1993** to United Energy Limited (ACN 064 651 029).

WHEREAS:

A. United Energy Limited (the licensee) is the holder of a licence under Part 12 of the **Electricity Industry Act 1993** (the Act) authorising it to sell electricity to franchise customers (a retail licence).

B. The licensee is also the holder of a licence under Part 12 of the Act authorising it to distribute electricity for supply, and to supply electricity, within the distribution area specified in the licence (a distribution licence) and is a distribution company for the purposes of the Act.

C. Insofar as the retail licence authorises the licensee to sell electricity to franchise customers (as defined in the Act) in relation to facilities in the distribution area where the licensee is authorised to distribute electricity for supply,

and to supply electricity, under its distribution licence, the licence so conferred is an exclusive licence.

D. Under section 163A of the Act the licensee is required to pay to the Treasurer, in respect of each financial year during which it holds, or held, an exclusive licence under Part 12 of the Act to sell electricity to franchise customers, the impost determined in respect of that year by Order of the Governor in Council, on the recommendation of the Treasurer, published in the Government Gazette before 30 June 1995 in the case of the impost in respect of the financial year ending on that date.

E. Having had regard to:

- (a) the terms of the Order made on 20 June 1995 under section 158A of the Act;
- (b) the value of the property and rights vested in each licensee under Parts 10 and 11 of the Act, as specified in the allocation statements made under Parts 10 and 11;
- (c) the amount of liabilities that became liabilities of each licensee under Parts 10 and 11 of the Act, as specified in the allocation statements made under Parts 10 and 11;
- (d) the likely number of franchise customers of the licensee in each of the years referred to in paragraph D above; and
- (e) such other matters as the Treasurer has determined after consultation with the licensee,

the Treasurer is satisfied that the amount set out in this Order in respect of the financial year ending on 30 June 1995 reasonably represents the amount by which the income of the licensee derived from the sale of electricity to franchise customers in that year is likely to exceed the sum of—

- (i) the costs of deriving the income; and
- (ii) taxes payable in deriving that income; and
- (iii) the amount determined by the Treasurer to be a reasonable return on the capital of that licensee used in deriving that income,

and the Treasurer has accordingly recommended to the Governor in Council that the amount set out in this Order be determined in respect of the licensee and that year under section 163A of the Act.

F. In anticipation of the making of this Order, the licensee has paid to the Treasurer, prior to the date of this Order, an amount of \$43,683,000 in respect of the financial year ending 30 June 1995.

NOW THEREFORE, THE GOVERNOR IN COUNCIL ACTING UNDER SECTION 163A OF THE ACT ORDERS THAT the amount payable by the licensee under section 163A of the Act in respect of the year ending 30 June 1995 is \$85,900,000 and the amount remaining after deducting the amount paid by the licensee as referred to in Recital F is to be paid by the licensee in a first instalment of \$10,317,000 on 26 June 1995 and a final instalment of \$31,900,000 on 17 July 1995.

Dated 20 June 1995

Responsible Minister:

ALAN R. STOCKDALE

Treasurer

KATHY WILSON
Clerk of the Executive Council

**Electricity Industry Act 1993
ORDER UNDER SECTION 163A**

Order determining the fee payable in respect of the licence to sell electricity to franchise customers issued under Part 12 of the Electricity Industry Act 1993 to CitiPower Limited (ACN 064 651 056).

WHEREAS:

A. CitiPower Limited (the licensee) is the holder of a licence under Part 12 of the Electricity Industry Act 1993 (the Act) authorising it to sell electricity to franchise customers (a retail licence).

B. The licensee is also the holder of a licence under Part 12 of the Act authorising it to distribute electricity for supply, and to supply electricity, within the distribution area specified in the licence (a distribution licence) and is a distribution company for the purposes of the Act.

C. Insofar as the retail licence authorises the licensee to sell electricity to franchise customers (as defined in the Act) in relation to facilities in the distribution area where the licensee is authorised to distribute electricity for supply, and to supply electricity, under its distribution licence, the licence so conferred is an exclusive licence.

D. Under section 163A of the Act the licensee is required to pay to the Treasurer, in respect of each financial year during which it holds, or held, an exclusive licence under Part 12 of the Act to sell electricity to franchise customers, the impost determined in respect of that year by Order of the Governor in Council, on the recommendation of the Treasurer, published in the Government Gazette before 30 June 1995 in the case of the impost in respect of the financial year ending on that date.

E. Having had regard to:

- (a) the terms of the Order made on 20 June 1995 under section 158A of the Act;
- (b) the value of the property and rights vested in each licensee under Parts 10 and 11 of the Act, as specified in the allocation statements made under Parts 10 and 11;
- (c) the amount of liabilities that became liabilities of each licensee under Parts 10 and 11 of the Act, as specified in the allocation statements made under Parts 10 and 11;
- (d) the likely number of franchise customers of the licensee in each of the years referred to in paragraph D above; and
- (e) such other matters as the Treasurer has determined after consultation with the licensee,

the Treasurer is satisfied that the amount set out in this Order in respect of the financial year ending on 30 June 1995 reasonably represents the amount by which the income of the licensee derived from the sale of electricity to franchise customers in that year is likely to exceed the sum of—

- (i) the costs of deriving the income; and
- (ii) taxes payable in deriving that income; and
- (iii) the amount determined by the Treasurer to be a reasonable return on the capital of that licensee used in deriving that income,

and the Treasurer has accordingly recommended to the Governor in Council that the amount set out in this Order be determined in respect of the licensee and that year under section 163A of the Act.

F. In anticipation of the making of this Order, the licensee has paid to the Treasurer, prior to the date of this Order, an amount of \$27,000,000 in respect of the financial year ending 30 June 1995.

NOW THEREFORE, THE GOVERNOR IN COUNCIL ACTING UNDER SECTION 163A OF THE ACT ORDERS THAT the amount payable by the licensee under section 163A of the Act in respect of the year ending 30 June 1995 is \$74,000,000 and the amount remaining after deducting the amount paid by the licensee as referred to in Recital F is to be paid by the licensee in a first instalment of \$3,000,000 on 26 June 1995 and a final instalment of \$44,000,000 on 17 July 1995.

Dated 20 June 1995

Responsible Minister:

ALAN R. STOCKDALE
Treasurer

KATHY WILSON
Clerk of the Executive Council

**Electricity Industry Act 1993
ORDER UNDER SECTION 163A**

Order determining the fee payable in respect of the licence to sell electricity to franchise customers issued under Part 12 of the Electricity Industry Act 1993 to Solaris Power Limited (ACN 064 651 083).

WHEREAS:

A. Solaris Power Limited (the licensee) is the holder of a licence under Part 12 of the Electricity Industry Act 1993 (the Act) authorising it to sell electricity to franchise customers (a retail licence).

B. The licensee is also the holder of a licence under Part 12 of the Act authorising it to distribute electricity for supply, and to supply electricity, within the distribution area specified in the licence (a distribution licence) and is a distribution company for the purposes of the Act.

C. Insofar as the retail licence authorises the licensee to sell electricity to franchise customers (as defined in the Act) in relation to facilities in the distribution area where the licensee is authorised to distribute electricity for supply, and to supply electricity, under its distribution licence, the licence so conferred is an exclusive licence.

D. Under section 163A of the Act the licensee is required to pay to the Treasurer, in respect of each financial year during which it holds, or held, an exclusive licence under Part 12 of the Act to sell electricity to franchise customers, the impost determined in respect of that year by Order of the Governor in Council,

on the recommendation of the Treasurer, published in the Government Gazette before 30 June 1995 in the case of the impost in respect of the financial year ending on that date.

E. Having had regard to:

- (a) the terms of the Order made on 20 June 1995 under section 158A of the Act;
- (b) the value of the property and rights vested in each licensee under Parts 10 and 11 of the Act, as specified in the allocation statements made under Parts 10 and 11;
- (c) the amount of liabilities that became liabilities of each licensee under Parts 10 and 11 of the Act, as specified in the allocation statements made under Parts 10 and 11;
- (d) the likely number of franchise customers of the licensee in each of the years referred to in paragraph D above; and
- (e) such other matters as the Treasurer has determined after consultation with the licensee,

the Treasurer is satisfied that the amount set out in this Order in respect of the financial year ending on 30 June 1995 reasonably represents the amount by which the income of the licensee derived from the sale of electricity to franchise customers in that year is likely to exceed the sum of—

- (i) the costs of deriving the income; and
- (ii) taxes payable in deriving that income; and
- (iii) the amount determined by the Treasurer to be a reasonable return on the capital of that licensee used in deriving that income,

and the Treasurer has accordingly recommended to the Governor in Council that the amount set out in this Order be determined in respect of the licensee and that year under section 163A of the Act.

F. In anticipation of the making of this Order, the licensee has paid to the Treasurer, prior to the date of this Order, an amount of \$16,600,000 in respect of the financial year ending 30 June 1995.

NOW THEREFORE, THE GOVERNOR IN COUNCIL ACTING UNDER SECTION 163A OF THE ACT ORDERS THAT the amount payable by the licensee under section 163A of the Act in respect of the year ending 30 June

1676 G 25 29 June 1995

1995 is \$38,000,000 and the amount remaining after deducting the amount paid by the licensee as referred to in Recital F is to be paid by the licensee in a first instalment of \$2,400,000 on 26 June 1995 and a final instalment of \$19,000,000 on 17 July 1995.

Dated 20 June 1995

Responsible Minister:

ALAN R. STOCKDALE
Treasurer

KATHY WILSON
Clerk of the Executive Council

Electricity Industry Act 1993
ORDER UNDER SECTION 163A

Order determining the fee payable in respect of the licence to sell electricity to franchise customers issued under Part 12 of the Electricity Industry Act 1993 to Eastern Energy Limited (ACN 064 651 118).

WHEREAS:

A. Eastern Energy Limited (the licensee) is the holder of a licence under Part 12 of the Electricity Industry Act 1993 (the Act) authorising it to sell electricity to franchise customers (a retail licence).

B. The licensee is also the holder of a licence under Part 12 of the Act authorising it to distribute electricity for supply, and to supply electricity, within the distribution area specified in the licence (a distribution licence) and is a distribution company for the purposes of the Act.

C. Insofar as the retail licence authorises the licensee to sell electricity to franchise customers (as defined in the Act) in relation to facilities in the distribution area where the licensee is authorised to distribute electricity for supply, and to supply electricity, under its distribution licence, the licence so conferred is an exclusive licence.

D. Under section 163A of the Act the licensee is required to pay to the Treasurer, in respect of each financial year during which it holds, or held, an exclusive licence under Part 12 of the Act to sell electricity to franchise customers, the impost determined in respect of that year by Order of the Governor in Council, on the recommendation of the Treasurer, published in the Government Gazette before 30 June 1995 in the case of the impost in respect of the financial year ending on that date.

Victoria Government Gazette

E. Having had regard to:

- (a) the terms of the Order made on 20 June 1995 under section 158A of the Act;
- (b) the value of the property and rights vested in each licensee under Parts 10 and 11 of the Act, as specified in the allocation statements made under Parts 10 and 11;
- (c) the amount of liabilities that became liabilities of each licensee under Parts 10 and 11 of the Act, as specified in the allocation statements made under Parts 10 and 11;
- (d) the likely number of franchise customers of the licensee in each of the years referred to in paragraph D above; and
- (e) such other matters as the Treasurer has determined after consultation with the licensee,

the Treasurer is satisfied that the amount set out in this Order in respect of the financial year ending on 30 June 1995 reasonably represents the amount by which the income of the licensee derived from the sale of electricity to franchise customers in that year is likely to exceed the sum of—

- (i) the costs of deriving the income; and
- (ii) taxes payable in deriving that income; and
- (iii) the amount determined by the Treasurer to be a reasonable return on the capital of that licensee used in deriving that income,

and the Treasurer has accordingly recommended to the Governor in Council that the amount set out in this Order be determined in respect of the licensee and that year under section 163A of the Act.

NOW THEREFORE, THE GOVERNOR IN COUNCIL ACTING UNDER SECTION 163A OF THE ACT ORDERS THAT the amount payable by the licensee under section 163A of the Act in respect of the year ending 30 June 1995 is \$12,000,000, payable in full on 17 July 1995.

Dated 20 June 1995

Responsible Minister:

ALAN R. STOCKDALE
Treasurer

KATHY WILSON
Clerk of the Executive Council

Financial Management Act 1994

Declaration of Bodies Corporate for reporting to the Parliament

The Governor in Council under section 53A (2) of the **Financial Management Act 1994** hereby declares that each of the following bodies corporate is a body to which section 53A of that Act applies and, under section 53A (3) of that Act, declares that the Minister specified opposite a body is the relevant Minister in relation to that body for the purposes of section 53A of that Act.

<i>Bodies</i>	<i>Relevant Minister</i>
<i>Companies</i>	
Driver Education Centre of Australia Ltd ACN 006 347 397	Minister for Education
Health Computing Services—Vic Ltd ACN 005 896 695	Minister for Health
Victorian Institute of Sport Ltd ACN 007 358 321	Minister for Sport, Recreation and Racing
<i>Denominational Hospitals</i>	
Bethlehem Hospital Incorporated Registered No. A00 112 33X	Minister for Health
Caritas Christi Hospice Ltd ACN 052 110 880	Minister for Health
Mercy Public Hospitals Incorporated Registered No. A00 098 48T	Minister for Health
O'Connell Family Centre (Grey Sisters) Incorporated Registered No. A00 211 63N	Minister for Health
St Vincent's Hospital (Melbourne) Ltd ACN 052 110 755	Minister for Health

Dated 20 June 1995

Responsible Minister:

ROGER MURRAY HALLAM

Minister for Finance

KATHY WILSON

Clerk of the Executive Council

**Alcoholics and Drug-dependent Persons
Act 1968****THE APPOINTMENT OF SERVICES AS
TREATMENT CENTRES**

Under section 5 (1) (b) of the **Alcoholics and Drug-dependent Persons Act 1968**, and on the recommendation of the Minister for Health, the Governor in Council Orders that the following services be appointed as residential centres for the care or treatment of alcoholics and drug-dependent persons.

- Addcare, 1030 Whitehorse Road, Box Hill 3128.
- Addrec: Alcohol and Drug Counselling Services, 3/10 Floriston Road, Boronia 3155.
- Barwon Regional Association for Alcohol and Drug Dependence, 59 Sydney Parade, Geelong 3220.
- Benalla Alcohol Recovery Unit, 56 Samaria Road, Benalla 3672.
- Bendigo Regional Alcohol and Drug Services, 93 Brougham Street, Bendigo 3350.
- Castlemaine CHC, Myring Street, Castlemaine 3450.
- Central Gippsland Alcohol and Drug Services, 26 Tarwin Street, Morwell 3840.
- Dandenong Hospital, David Street, Dandenong 3175.
- Drug Users and Patient Aid Foundation Inc., 10 Small Street, Hampton 3188.
- Maroondah Alcoholics Recovery Program, 86 Brice Avenue, Mooroolbark 3138.
- Maroondah Social Health Service, 75 Patterson Street, Ringwood East 3134.
- Moreland Hall, 26 Jessie Street, Coburg 3058.
- North East Drug and Alcohol Services, 10 Stanley Street, Wodonga 3690.
- Odyssey House, 173 Greville Street, Prahran 3181.
- Palm Lodge Rehabilitation Centre, 25 David Street, Horsham 3400.
- Peninsula Alcohol and Drug Dependence Assistance Centres, 787 Nepean Highway, Rosebud 3939 and 2 Hastings Road, Frankston 3199.
- Salvation Army, Bridge Haven, 20 Cohuna Street, West Brunswick 3055.

18. Salvation Army—Bridge Program, 12 Chapel Street, St Kilda 3182.

19. St Vincent's Hospital, 28 Nicholson Street, Fitzroy 3065.

20. Sunraysia Drug and Alcohol Rehabilitation Information Services, 30 Chaffey Avenue, Mildura 3500.

21. Swan Hill and District CHC, 13 Pritchard Street, Swan Hill 3585.

22. Task Force Community Involvement Centre, 165 Greville Street, Prahran 3181.

23. The Anchorage, 50 Victoria Crescent, Abbotsford, 3067.

24. The Corner House, 4 Mountview Street, Croydon 3136.

25. The Royal Women's Hospital Chemical Dependency Unit, 266 Cardigan Street, Carlton 3053.

26. Valley Alcohol Drug Counselling and Referral Education, 13 Marungi Street, Shepparton 3630.

27. Warrnambool Regional Association for Alcohol and Drug Dependence, 325 Timor Street, Warrnambool 3280.

28. WESTADD Women's Residential Withdrawal/Rehabilitation Unit, 49 Nicholson Street, Footscray 3011.

29. Western Hospital, Gordon Street, Footscray 3011.

30. Westernport Drug and Alcohol Services Ltd., 106 Cleeland Street, Dandenong 3175.

31. Windana Society, PO Box 372, St Kilda 3182.

Dated 20 June 1995

Responsible Minister:

MARIE TEHAN

Minister for Health

KATHY WILSON
Clerk of the Executive Council

Alcoholics and Drug-dependent Persons Act 1968

THE APPOINTMENT OF SERVICES AS ASSESSMENT CENTRES

Under section 5 (1) (a) of the **Alcoholics and Drug-dependent Persons Act 1968**, and on the recommendation of the Minister for Health, the Governor in Council Orders that the following services be appointed as assessment centres for the reception and classification of alcoholics and drug-dependent persons.

1. Benalla Alcohol Recovery Unit, 56 Samaria Road, Benalla 3672.

2. Dandenong Hospital, David Street, Dandenong 3175.

3. Maroondah Alcoholics Recovery Program, 86 Brice Avenue, Mooroolbark 3138.

4. Moreland Hall, 26 Jessie Street, Coburg 3058.

5. Odyssey House, 173 Greville Street, Prahran 3181.

6. Palm Lodge Rehabilitation Centre, 25 David Street, Horsham 3400.

7. Quay West, 71 Moreland Street, Footscray 3011.

8. Salvation Army—Bridge Haven, 20 Cohuna Street, West Brunswick 3055.

9. Salvation Army—Bridge Program, 12 Chapel Street, St. Kilda 3182.

10. St Vincent's Hospital, 28 Nicholson Street, Fitzroy 3065.

11. The Royal Women's Hospital Chemical Dependency Unit, 266 Cardigan Street, Carlton 3053.

12. WESTADD Women's Residential Withdrawal/Rehabilitation Unit, 49 Nicholson Street, Footscray 3011.

13. Western Hospital, 14 Gordon Street, Footscray 3011.

14. Windana Society, PO Box 372, St Kilda 3182.

Dated 20 June 1995

Responsible Minister:

MARIE TEHAN

Minister for Health

KATHY WILSON
Clerk of the Executive Council

**Historic Buildings Act 1981 (No. 9667)
AMENDMENT OF REGISTER OF
HISTORIC BUILDINGS**

Under section 14 of the **Historic Buildings Act 1981** the Governor in Council amends the Register by adding Historic Building No. 1089:

Wesleyan Church and Sunday School Hall corner Lydiard Street South and Dana Street, Ballarat, Shire of Ballarat.

Extent:

- (1) All of the building known as the former Wesleyan Church and Sunday School Hall.

- (2) All of the land set aside as Crown Land for the Wesleyan Church marked L-1 on Plan 600205 endorsed by the Chair, Historic Buildings Council and held by the Director, Historic Buildings Council.

Owners: Uniting Church.

Dated 20 June 1995

Responsible Minister:

ROBERT MACLELLAN
Minister for Planning

KATHY WILSON
Clerk of the Executive Council

**Historic Buildings Act 1981 (No. 9667)
AMENDMENT OF REGISTER OF
HISTORIC BUILDINGS**

Under section 14 of the Historic Buildings Act 1981 the Governor in Council amends the Register by adding Historic Building No. 1005:

Cairo Flats, 98 Nicholson Street, Fitzroy, City of Yarra

(To the extent of:

1. All of the building known as Cairo Flats, 98 Nicholson Street, Fitzroy, including the former dining room (now milkbar) and the garages, being the building marked B-1, B-2 and B-3 on Plan 6012828(A), endorsed by the Chairperson, Historic Buildings Council and held by the Director, Historic Buildings Council, but excluding the perimeter wall.
2. All of the land described in Memorial No. 965 Book 551 and Memorial No. 836 Book 551, being portion of suburban Section Number 70, in the Parish of Jika Jika, marked L-1 on Plan 6012828(B), endorsed by the Chairperson, Historic Buildings Council and held by the Director, Historic Buildings Council.)

Dated 14 June 1995

Responsible Minister:

ROBERT MACLELLAN
Minister for Planning

KATHY WILSON
Clerk of the Executive Council

**Public Sector Management Act 1992
AMENDMENT TO SCHEDULE 1**

The Governor in Council, by Order under section 108 (1) and (2) of the Public Sector Management Act 1992, amends Schedule 1 of that Act by:

- (1) Omitting, in relation to the "Department of Justice" in column 1, the name of the administrative office of "Office of the Chief Parliamentary Counsel" in column 3;
- (2) Omitting, in relation to the administrative office of "Office of the Chief Parliamentary Counsel" in column 3, the title of the position of "Chief Parliamentary Counsel" in column 4;
- (3) Inserting, in relation to the "Department of Premier and Cabinet" in column 1, the name of the administrative office of "Office of the Chief Parliamentary Counsel" in column 3; and
- (4) Inserting, in relation to the administrative office of "Office of the Chief Parliamentary Counsel" in column 3, the title of the position of "Chief Parliamentary Counsel" in column 4.

with effect on and from 1 July 1995.

Dated 20 June 1995

Responsible Minister:

J. G. KENNETT
Premier

KATHY WILSON
Clerk of the Executive Council

**Corrections Act 1986
APPOINTMENT OF A POLICE GAOL**

The Governor in Council appoints under section 11 of the Corrections Act 1986 the premises described hereunder to be a police gaol to hold a person for a term not exceeding one day.

Police Lock Up: Falls Creek Police Gaol.

Address: Visitors Centre, Alpine Resorts Commission, Bogong High Plains Road, Falls Creek.

Location of Lock Up: One cell, south east corner on ground floor of the Falls Creek Police Station.

Description of Lock Up: Concrete floor, concrete block walls.

1680 G 25 29 June 1995

Crown Description: Part of Parcel No. 5 on SP 18598A, Bogong High Plains Road, Falls Creek Alpine Resort.

Dated 27 June 1995

Responsible Minister:

PATRICK McNAMARA
Deputy Premier
Minister for Corrections

KATHY WILSON
Clerk of the Executive Council

Corrections Act 1986
AMENDMENT OF APPOINTMENTS OF PRISONS

Under section 10 of the Corrections Act 1986 the Governor in Council amends the following Orders for the appointment of prisons—

Order of Appointment for the Dandenong Reception Centre dated 2 November 1994 after "attached plan" delete "being" and insert "including".

Order of Appointment for the Keilor Downs Reception Centre dated 16 November 1993 after "north of the" insert "charge".

Dated 27 June 1995

Responsible Minister:

PATRICK McNAMARA
Deputy Premier
Minister for Corrections

KATHY WILSON
Clerk of the Executive Council

Forests Act 1958
ORDER FIXING THE DAY ON WHICH FALLS CREEK ALPINE RESORT CEASES TO BE PROTECTED PUBLIC LAND

The Governor in Council, under section 62 (1B) of the Forests Act 1958, fixes 1 July 1995 as the day on which section 62 (1A) (e) of the Forests Act 1958 ceases to apply to the following land which is under the control and management of the Alpine Resorts Commission, under the Alpine Resorts Act 1983:

The Fall's Creek alpine resort within the meaning of the Alpine Resorts Act 1983, being—

- (a) the land declared by the Governor in Council to be an alpine resort under section 19 of the Alpine Resorts Act

Victoria Government Gazette

1983 by Order published in Government Gazette No. 36 on 17 April 1985 (page 1132); and

- (b) the land added to the Fall's Creek alpine resort by virtue of section 43 of the Alpine Resorts Act 1983.

Dated 27 June 1995

Responsible Minister:

C. G. COLEMAN
Minister for Natural Resources

KATHY WILSON
Clerk of the Executive Council

Land Act 1958
SURRENDER OF LAND TO THE CROWN BY A PUBLIC AUTHORITY UNDER THE PROVISIONS OF SECTION 22A

The Governor in Council under section 22A of the Land Act 1958, consents to the Grain Elevators Board surrendering to the Crown the land described below:

The whole of the land enclosed by continuous thick lines on the attached Plan for Surrender Purposes and being part of the land in Certificate of Title Volume 9702 Folio 096.

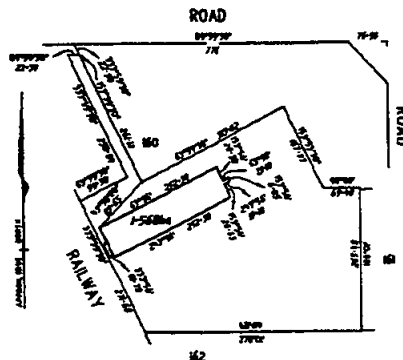

Dated 27 June 1995

Responsible Minister:

BILL McGRATH
Minister for Agriculture

KATHY WILSON
Clerk of the Executive Council

Health Services Act 1988
THE AMALGAMATION OF DAYLESFORD
AND DISTRICT COMMUNITY HEALTH
CENTRE INCORPORATED WITH THE
WESTERN HIGHLANDS HEALTH
SERVICE TO BE KNOWN AS WESTERN
HIGHLANDS HEALTH SERVICE

The Governor in Council, on the recommendation of the Minister for Health made after receiving advice from the Secretary to the Department of Health and Community Services (the Secretary) under section 64 of the **Health Services Act 1988** that the Daylesford and District Community Health Centre Inc and Western Highlands Health Service amalgamate, and acting under section 65 of that Act, by this Order—

1. Directs that under section 65 (1) of the Act the Daylesford and District Community Health Centre Inc and the Western Highlands Health Service be amalgamated.

2. Specifies 1 July 1995 as the date on which—

- (a) the incorporation of the former Daylesford and District Community Health Centre Inc and the Western Highlands Health Service shall be cancelled; and
- (b) a new registered funded agency to be known as the Western Highlands Health Service shall come into existence as if on that date it had been incorporated under the **Health Services Act 1988**;
- (c) the initial Board of Management of the new Western Highlands Health Service will be constituted comprising the following members for the period of office as specified:

<i>Members of the Board of Management</i>	<i>Appointed until</i>
Maxwell John O'Shea	31 October 1997
Neil Eric Chamberlain	31 October 1997
Stanley Alwynne Baker	31 October 1997
Gary Alan Chandler	31 October 1997
Margaret Frances Edgar	31 October 1996
Robert Gilmour Orr	31 October 1996
Thomas Kane	31 October 1996
Christopher Robert Murphy	31 October 1996
Peter William Anderson	31 October 1995
Ernest John Robinson	31 October 1995
Colin Neville Wrigley	31 October 1995

3. Orders pursuant to section 65 (3) of the **Health Services Act 1988** that:

- (a) the by-laws of the new Western Highlands Health Service are to be the by-laws contained in the copy of the by-laws approved by the delegate of the Secretary on 1 July 1995 and as altered by the Western Highlands Health Service from time to time in accordance with the **Health Services Act 1988**; and
- (b) the purposes of the new Western Highlands Health Service are the purposes stated in the statement of purposes approved by the delegate of the Secretary on 1 July 1995 and as altered by the Western Highlands Health Service from time to time in accordance with the **Health Services Act 1988**.

4. Declares that under section 65 (4) of the **Health Services Act 1988** the new Western Highlands Health Service is a public hospital under the **Health Services Act 1988** with effect from 1 July 1995.

5. Amends Schedule 1 of the **Health Services Act 1988** pursuant to sections 8 (1) (a) and (b) with effect from 1 July 1995 by:

- (a) adding the name of the new Western Highlands Health Service; and
- (b) removing the name of the former Western Highlands Health Service.

Dated 27 June 1995

Responsible Minister:

MARIE TEHAN
 Minister for Health

KATHY WILSON
 Clerk of the Executive Council

Health Services Act 1988
THE AMALGAMATION OF COLAC
DISTRICT HOSPITAL, COLAC AREA
COMMUNITY HEALTH SOCIETY
INCORPORATED AND COLAC HOUSING
AND FINANCIAL COUNSELLING
SERVICE INCORPORATED TO BE KNOWN
AS COLAC COMMUNITY HEALTH
SERVICES

The Governor in Council, on the recommendation of the Minister for Health made after receiving advice from the Secretary to the Department of Health and Community

Services (the Secretary) under section 64A of the **Health Services Act 1988** that the governing bodies of the Colac District Hospital, the Colac Area Community Health Society Incorporated and the Colac Housing and Financial Counselling Service Incorporated have agreed to amalgamate, and acting under section 65 of that Act, by this Order—

1. Directs that under section 65 (1) of the Act the Colac District Hospital, the Colac Area Community Health Society Incorporated and the Colac Housing and Financial Counselling Service Incorporated be amalgamated.

2. Specifies 1 July 1995 as the date on which—

- (a) the incorporation of the Colac District Hospital, the Colac Area Community Health Society Incorporated and the Colac Housing and Financial Counselling Service Incorporated shall be cancelled; and
- (b) a new registered funded agency to be known as Colac Community Health Services shall come into existence as if on that date it had been incorporated under the **Health Services Act 1988**; and
- (c) the initial Board of Management of the Colac Community Health Services will be constituted comprising the following members for the period of office as specified:

<i>Members of the Board of Management</i>	<i>Appointed until</i>
Jacqueline Margaret Campbell	30 June 1998
Peter Fraser Falkiner	30 June 1998
Barry James Matthews	30 June 1998
Christian Scott Sutherland	30 June 1998
Peter Boyd Mercer	31 October 1997
Joan Roberta Hay	31 October 1997
Rosemary Richardson	31 October 1997
David McIntosh Sears	31 October 1997
John Warwick Bartlett	31 October 1996
Gael Maxine Margaret Perry	31 October 1996
Roslyn Thais Scanlan	31 October 1996
Dawn Heather Swayn	31 October 1996

3. Orders pursuant to section 65 (3) of the **Health Services Act 1988** that:

- (a) the by-laws of the Colac Community Health Services are to be the by-laws contained in the copy of the by-laws

approved by the delegate of the Secretary on 1 July 1995 and as altered by the Colac Community Health Services from time to time in accordance with the **Health Services Act 1988**; and

- (b) the purposes of the Colac Community Health Services are the purposes stated in the statement of purposes approved by the delegate of the Secretary on 1 July 1995 and as altered by the Colac Community Health Services from time to time in accordance with the **Health Services Act 1988**.

4. Declares that under section 65 (4) of the **Health Services Act 1988** the Colac Community Health Services is a public hospital under the **Health Services Act 1988** with effect from 1 July 1995.

5. Amends Schedule 1 of the **Health Services Act 1988** pursuant to sections 8 (1) (a) and (b) with effect from 1 July 1995 by:

- (a) adding the name Colac Community Health Services; and
- (b) removing the name of the Colac District Hospital.

Dated 27 June 1995

Responsible Minister:
MARIE TEHAN
Minister for Health

KATHY WILSON
Clerk of the Executive Council

Project Development and Construction Management Act 1994
APPLICATION ORDER

The Governor in Council under section 8 of the **Project Development and Construction Management Act 1994** ("the Act"), specifies the provisions, listed below, which are to apply in relation to the nominated project, being the National Air and Space Museum of Australia at Point Cook, to the responsible Minister and to the nominated facilitating agency being the Secretary to the Department of Planning and Development;

- (a) all the provisions of Part 3 of the Act are to apply in relation to the nominated project;
- (b) all the provisions of Part 3 of the Act are to apply to the facilitating agency for the nominated project;

- (c) in accordance with section 28 of the Act, the facilitating agency is deemed to be an authority for the purposes of the **Borrowing and Investment Powers Act 1987** and to be such an authority to which each of the sections listed in section 28 (b) of the Act apply;
- (d) that sections 20, 23 and 24 of the Act apply to the responsible Minister for the nominated project.

Dated 27 June 1995
Responsible Minister:
J. G. KENNETT
Premier

KATHY WILSON
Clerk of the Executive Council

State Owned Enterprises Act 1992
ORDER UNDER SECTION 14

(1) The Governor in Council acting under section 14 of the **State Owned Enterprises Act 1992** and all other powers reappoints the Board of Directors of the Victorian Interpreting and Translating Service, consisting of:

Mr Eugene Smarrelli (Chairman);
Mrs Danielle Kemp; and
Mr John O'Callaghan

for a period commencing on 1 July 1995 and ending on either:

- (a) 31 October 1995; or
(b) the date on which the Victorian Interpreting and Translating Service is declared under section 66 of **State Owned Enterprises Act 1992** to be a State owned company—

whichever event occurs first.

(2) The terms and conditions of appointment of the directors are as follows:

- (a) subject to clause (3), the Chairman is entitled to be paid remuneration at the rate of \$245 per session;
- (b) subject to clause (3), each of the other directors is entitled to be paid remuneration at the rate of \$190 per session;
- (c) the Governor in Council may at any time remove a director from office; and
- (d) each director is eligible for re-appointment.

(3) A director who is a member of the public service is not entitled to be paid remuneration under this Order.

Dated 27 June 1995
Responsible Minister:

J. G. KENNETT
Minister for Ethnic Affairs

KATHY WILSON
Clerk of the Executive Council

Local Government Act 1989
ORDER ALTERING THE NAME AND
CONSTITUTION OF MILAWA SHIRE
COUNCIL TO THE WANGARATTA RURAL
CITY COUNCIL

The Governor in Council acting under subsections 220Q (g) and (h) of Part 10C of the **Local Government Act 1989** orders that:

1. Commencement

This Order comes into operation on the day it is published in the Government Gazette.

2. Alteration of Name and Constitution of the Milawa Shire Council

The body corporate constituted as a Shire Council by the name of the Milawa Shire Council is hereby constituted as a Rural City Council by the name of the Wangaratta Rural City Council.

Dated 27 June 1995

Responsible Minister:

ROGER M. HALLAM
Minister for Local Government

KATHY WILSON
Clerk of the Executive Council

**SUBORDINATE LEGISLATION ACT 1994
NOTICE OF MAKING OF STATUTORY
RULES**

Notice is given under section 17 (2) of the Subordinate Legislation Act 1994 of the making of the following Statutory Rules:

77. *Statutory Rule:* Hospitals Superannuation (Amendment) Regulations 1995
Authorising Act: Hospitals Superannuation Act 1988
Date of Making: 27 June 1995
78. *Statutory Rule:* Audit (Public Bodies) Regulations 1995
Authorising Act: Audit Act 1994
Date of Making: 27 June 1995
79. *Statutory Rule:* Lotteries Gaming and Betting (Raffles and Bingo Permits) (Miscellaneous) Regulations 1995
Authorising Act: Lotteries Gaming and Betting Act 1966
Date of Making: 27 June 1995
80. *Statutory Rule:* Chiropractors and Osteopaths (Qualifications) Regulations 1995
Authorising Act: Chiropractors and Osteopaths Act 1978
Date of Making: 27 June 1995
81. *Statutory Rule:* Occupational Health and Safety (Plant) Regulations 1995
Authorising Act: Occupational Health and Safety Act 1985
Date of Making: 27 June 1995
82. *Statutory Rule:* Equipment (Public Safety) (General) Regulations 1995
Authorising Act: Equipment (Public Safety) Act 1994
Date of Making: 27 June 1995
83. *Statutory Rule:* Occupational Health and Safety (Certification of Plant Users and Operators) (Miscellaneous Amendments) Regulations 1995
Authorising Act: Occupational Health and Safety Act 1985
Date of Making: 27 June 1995
84. *Statutory Rule:* Fisheries (Scallop) Regulations 1995
Authorising Act: Fisheries Act 1968
Date of Making: 27 June 1995

85. *Statutory Rule:* Road Safety (Vehicles) (Defective Vehicles) Regulations 1995

Authorising Act: Road Safety Act 1986

Date of Making: 27 June 1995

86. *Statutory Rule:* Stamps (Bookmakers) Regulations 1995

Authorising Act: Stamps Act 1958

Date of Making: 27 June 1995

**SUBORDINATE LEGISLATION ACT 1994
NOTICE THAT STATUTORY RULES ARE
OBTAINABLE**

Notice is given under section 17 (3) of the Subordinate Legislation Act 1994 that the following Statutory Rules were first obtainable from Information Victoria, 318 Little Bourke Street, Melbourne on the date specified:

81. *Statutory Rule:* Occupational Health and Safety (Plant) Regulations 1995
Authorising Act: Occupational Health and Safety Act 1985
Date first obtainable: 1 July 1995
Code D
82. *Statutory Rule:* Equipment (Public Safety) (General) Regulations 1995
Authorising Act: Equipment (Public Safety) Act 1994
Date first obtainable: 1 July 1995
Code C
83. *Statutory Rule:* Occupational Health and Safety (Certification of Plant Users and Operators) (Miscellaneous Amendments) Regulations 1995
Authorising Act: Occupational Health and Safety Act 1985
Date first obtainable: 1 July 1995
Code A

The retail prices and price codes below will apply from 2 August 1993 to the following products: Acts (New, Reissue and Reprint), Statutory Rules (New, Reissue and Reprint), Parliamentary Papers, Bills and Reports, Special and Periodical Gazettes, and Industrial Awards.

<i>Price Code</i>	<i>No. of Pages (Including cover and blank pages)</i>	<i>Price</i>
A	1-16	\$2.70
B	17-32	\$4.00
C	33-48	\$5.50
D	49-96	\$8.50
E	97-144	\$11.00
F	145-192	\$13.00
G	193-240	\$15.00
H	241-288	\$16.00
I	289-352	\$18.00
J	353-416	\$21.00
K	417-480	\$24.00
L	481-544	\$28.00

A set retail price per issue will apply from 2 August 1993 to:

Government Gazette (General) \$1.65 per issue
Hansard (Weekly) \$2.70 per issue

ADVERTISERS PLEASE NOTE

As from 29 June 1995

The last Special Gazette was No. 63
Dated 29 June 1995

The last Periodical Gazette was No. 3
Dated 20 June 1995

1686 G 25 29 June 1995

Victoria Government Gazette





CONTENTS

	Page
Acts of Parliament	1585
Estates of Deceased Persons	1543
Government and Outer Budget Sector Agencies Notices	1588
Notice of Making of Statutory Rules	1684
Orders in Council—	
Acts—Crown Land (Reserves); County Court; Land; Electricity Industry; Financial Management; Alcoholics and Drug-dependent Persons; Historic Buildings; Corrections; Forests; Health Services; Project Development and Construction Management; State Owned Enterprises; Local Government	1617
Private Advertisements	1543
Proclamations	1585

A Printing and Publishing Services Victoria Publication

Published by Law Press

Printed by The Law Printer

a business unit of

Printing and Publishing Services Victoria (PPSV)

Melbourne Victoria Australia

© State of Victoria 1995

ISSN 0819—5471

This publication is copyright. No parts may be reproduced
by any process except in accordance with the provisions
of the Copyright Act.

Address all inquiries to the Government Printer
for the State of Victoria

PO Box 292 South Melbourne 3205 Victoria Australia

L. V. North, Government Printer Melbourne

Wholesale Sales

Law Press

PO Box 292 South Melbourne 3205

Telephone inquiries (03) 242 4600

Fax (03) 242 4699

Subscriptions

Law Press

PO Box 292 South Melbourne 3205

Telephone inquiries (03) 242 4606

Fax (03) 242 4699

Retail Sales

Information Victoria Bookshop

318 Little Bourke Street Melbourne 3000

Telephone inquiries (03) 651 4100

Recommended Retail Price \$1.65